

# FILM-TECH

**THE INFORMATION CONTAINED IN THIS ADOBE ACROBAT PDF FILE IS PROVIDED AT YOUR OWN RISK AND GOOD JUDGMENT.**

**THESE MANUALS ARE DESIGNED TO FACILITATE THE EXCHANGE OF INFORMATION RELATED TO CINEMA PROJECTION AND FILM HANDLING, WITH NO WARRANTIES NOR OBLIGATIONS FROM THE AUTHORS, FOR QUALIFIED FIELD SERVICE ENGINEERS.**

**IF YOU ARE NOT A QUALIFIED TECHNICIAN, PLEASE MAKE NO ADJUSTMENTS TO ANYTHING YOU MAY READ ABOUT IN THESE ADOBE MANUAL DOWNLOADS.**

**[WWW.FILM-TECH.COM](http://WWW.FILM-TECH.COM)**

BELL & HOWELL

-F I L M O A R C-

Models 140-L & 140-M

16mm. Sound-on-Film Reproducer

oOo

INSTRUCTIONS  
and  
MANUAL OF OPERATION

**BELL & HOWELL**

*Filmoarc*

**16MM PROJECTOR**

BELL & HOWELL COMPANY  
7100 McCormick Road  
Chicago 45, Illinois

the  
open door  
to  
pictures  
of  
perfection  
with your

**BELL & HOWELL**

*Filmoarc*

**16MM PROJECTOR**



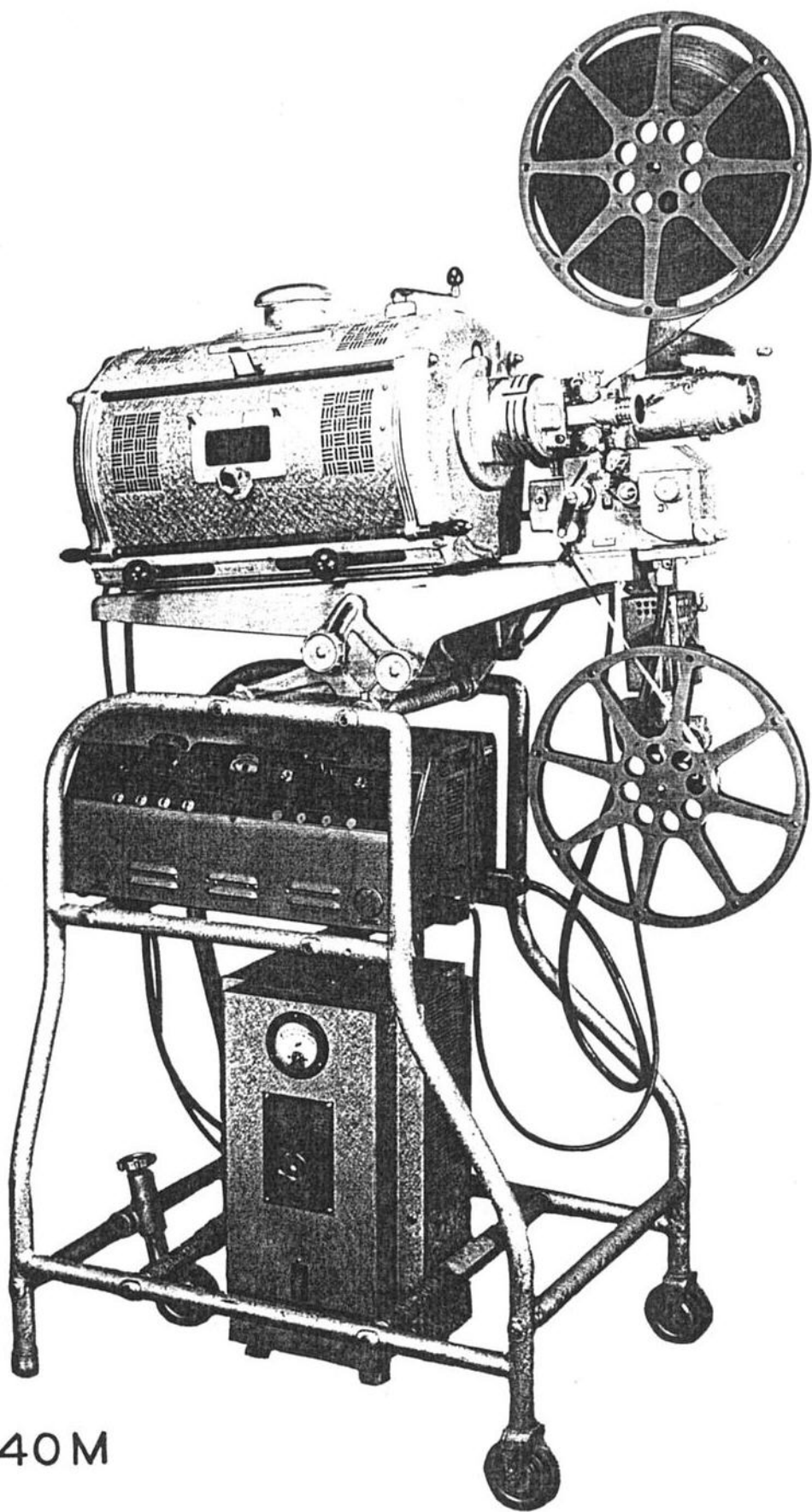

140M

RHODIUM REFLECTOR  
1300 LUMENS

S.M.P.T.E. JOURNAL MAY 1950



Bell & Howell's Filmoarc Model 140 U with amplifier and rectifier completely housed in streamlined base. Connecting cables are concealed for smooth exterior appearance.

## FILMOARC PROJECTOR

### SETTING UP THE 140-M STAND

The stand, of the Model 140-M, Rollaway, wheel-type stand, is composed of two main side frame sections (A, Plate 401). In addition to this, there are six other loose metal cross pieces (B, Plate 401) concave at either end, in order to fit over the strut members of the side frame of the stand.

Sixteen screws and washers are needed to assemble the stand. The top platform of the stand (D, Plate 401), which provides the mounting base for the lamphouse and projector head, also include the tilt mechanism. (E, Plate 401).

Having segregated and identified the various parts of the stand assembly, examine carefully the parts represented in Plate 402 and follow the method shown in that figure to insert the first of the bottom cross pieces. Plate 403 shows the first step in the assembly of the stand.

Do not tighten down any of these screws in the side frame assembly until the arc lamp base (D, Plate 401) has been installed in the top position of the stand as shown in Figure 404. If you tighten down the screws before coming to the top of the frame, they will have to be loosened in order to permit the insertion of the lamp base.

Carefully examine Plate 404. It will help you identify the various cross members. It is self-evident that the longer plain brace fits at the bottom, front of the stand. This is essential in order to give the stand members their proper separation. The brace having the wheel attached (B, Plate 404) fits in the rear and at the bottom. The two longer members having a rubber sleeving covering a portion of their length are installed in the bottom section of the stand (D, Plate 404). It is upon these two hangers, that the rectifier is mount-

ed—later in the assembly procedure.

Note carefully the wheel on the lower rear brace member. This is intended to make the stand readily movable. To move the stand, turn the wheel nut (E,

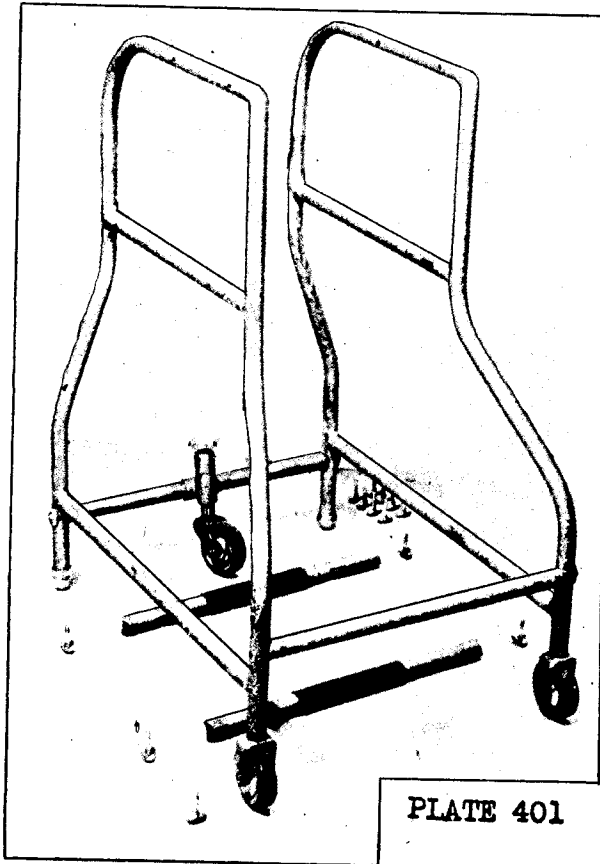
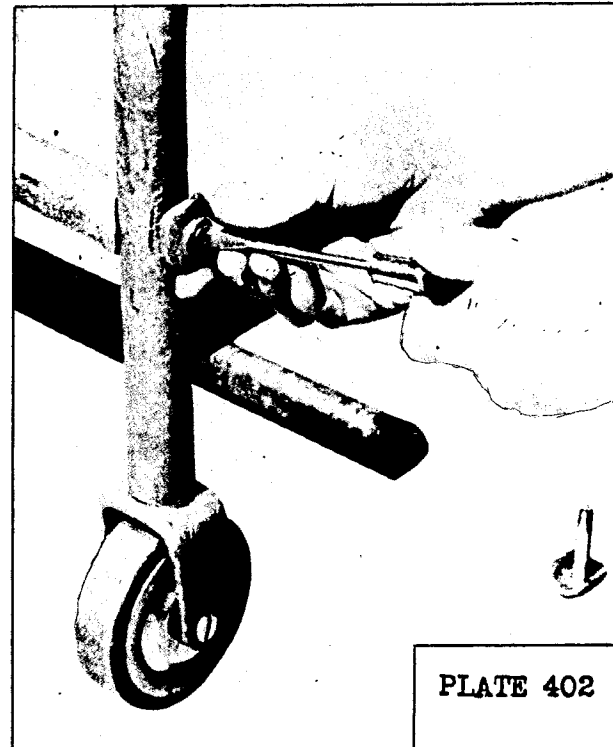

Plate 404) at the top of this caster clockwise. This will force the wheel into contact with the floor, and lift the rear legs of the projector stand clear of the floor. The stand may then be rolled around on the two front wheels and this one rear wheel. At all times when the projector is in operation, and at such times as it is desired not to have it moved, this wheel should be retracted so as to permit the rear legs to contact the floor

evenly.

During the assembly, note that the ball at the base of the rear leg is extensible. This may be used to level the projector, so that the light beam will be square with the screen. By turning, either to the left or right,



the one corner of the stand may be raised or lowered to compensate for irregularities in the floor.

After the projector base has been mounted upon the frame, begin with the bottom assembly nut and retighten all of them a bit at a time. Do not tighten any one of them down as tightly as possible, but take each of them down a few turns, and after following this procedure, repeat until you have tightened all of them firmly, but not to the limits of your ability since tightening them too tightly would make the stand unnecessarily difficult to disassemble. The completely assembled stand should appear as in Plate 404.

## SETTING UP MODEL 140-L

The threaded portions of the four legs, A, B, C, and D, in Plate 405, are all alike. They are screwed into the sockets, 1, 2, 3 and 4 (3 and 4 not visible).

Screw them in until they seat firmly, but do not force them or use any tools on them.

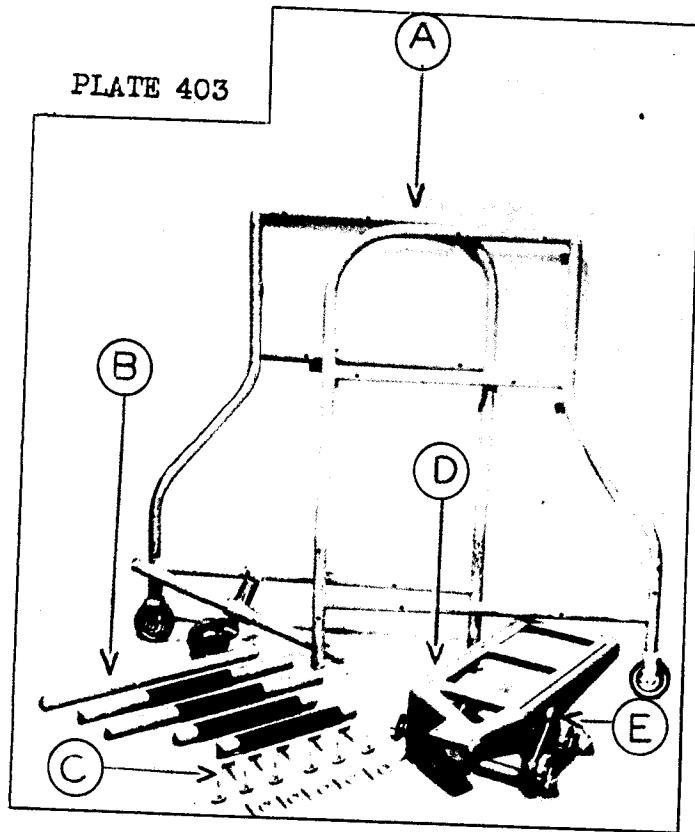

Raising and lowering the projector, as well as tilting it, is accomplished by turning the barrel (A, Plate 406) after loosening about  $1\frac{1}{2}$  turns the lock nut (B, Plate 406). When the lock nut B is loosened, the leg will not slip in or out. It must be turned or screwed in or out, as required, to raise or lower the stand.

After all the legs are inserted in the sockets, and extended to approximately the height you require, the machine is set up in the same way as the Model 140-M.

Further adjustment is made on these extension legs after the lamp is in operation. The machine can be raised or lowered, as required, to center the picture on the screen.

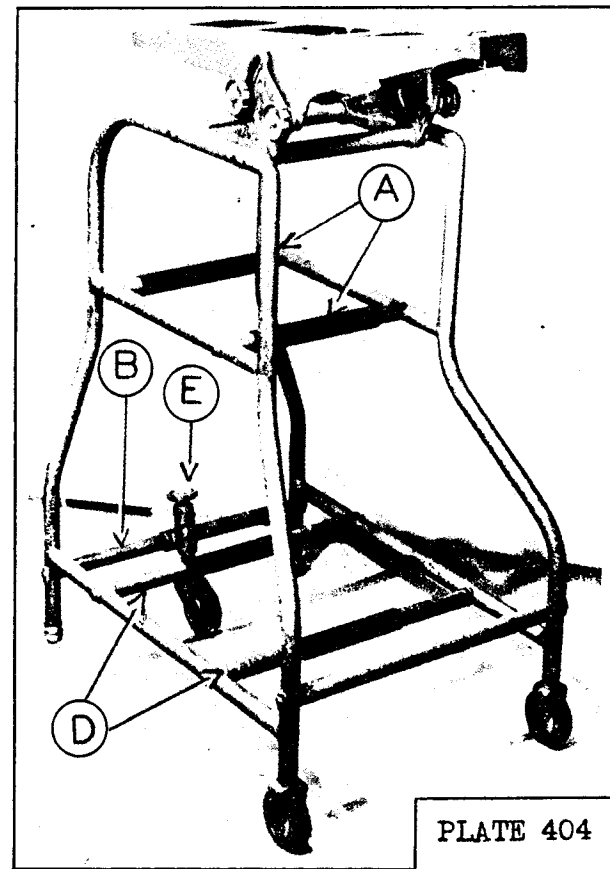

The amplifier stand for the Model 140-L projector is in three parts. A top portion (E, Plate 405) and two side leg portions (F and G, Plate 405). The top portion



## POWER REQUIREMENTS

The rectifier only, requires about 1850-watts, the amplifier about 250-watts. The house line to which it is connected should be fused at least 25 amperes, preferably more. A protective device is included inside the rectifier line switch, so that should any difficulty de-

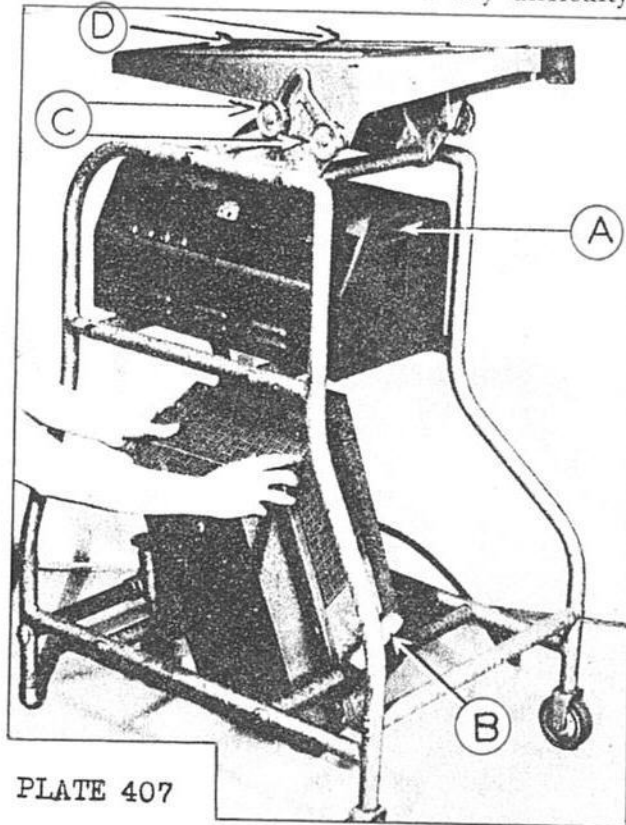

PLATE 407

velop within the arc of the rectifier, the switch will automatically cut out. This cut-out is accomplished within the workings of the switch itself and the switch still remains in the "on" position.

## MOUNTING THE RECTIFIER

Be sure at this time, that the rear (third) wheel is

lifted from the floor so that the stand will not skid around while you are mounting the rectifier and completing the assembly.

Carefully observe Plate 407. Lift the rectifier into position, bottom end first, so that the two mounting hooks on the lower sides of the rectifier will engage

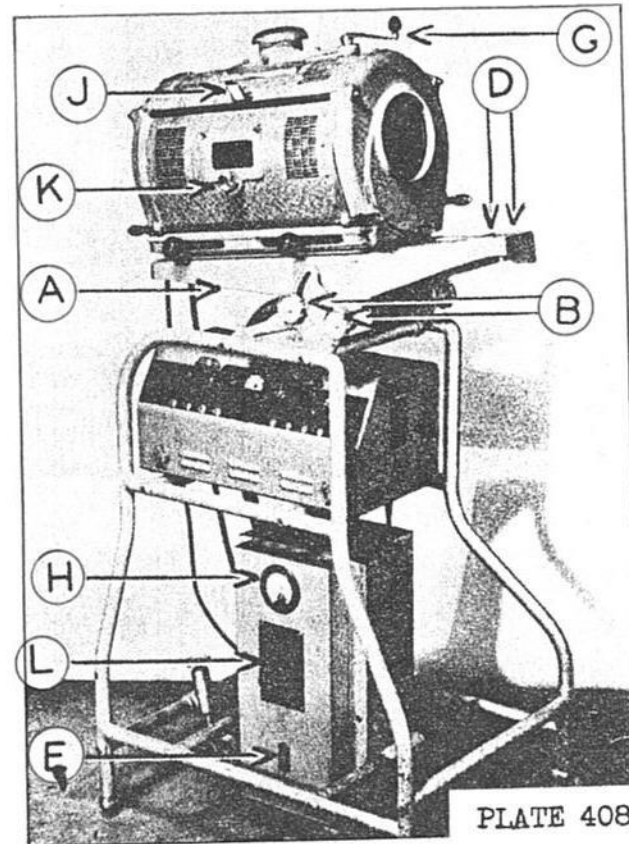

PLATE 408

with the two rubber-covered struts of the stand (B, Plate 405). Slide the bottom of the rectifier well away from you, so that the top may be tilted in and under the amplifier. After it is setting vertically, move the bottom of it toward you again so as to center the rectifier on the two mounting struts.

## INSTALLING THE AMPLIFIER

Next grasp the amplifier by the hand holes in the upper portion of either end, and rest it on the platform formed by the middle section of the stand (See A in Plate 407). Center it on the rubber cushion.

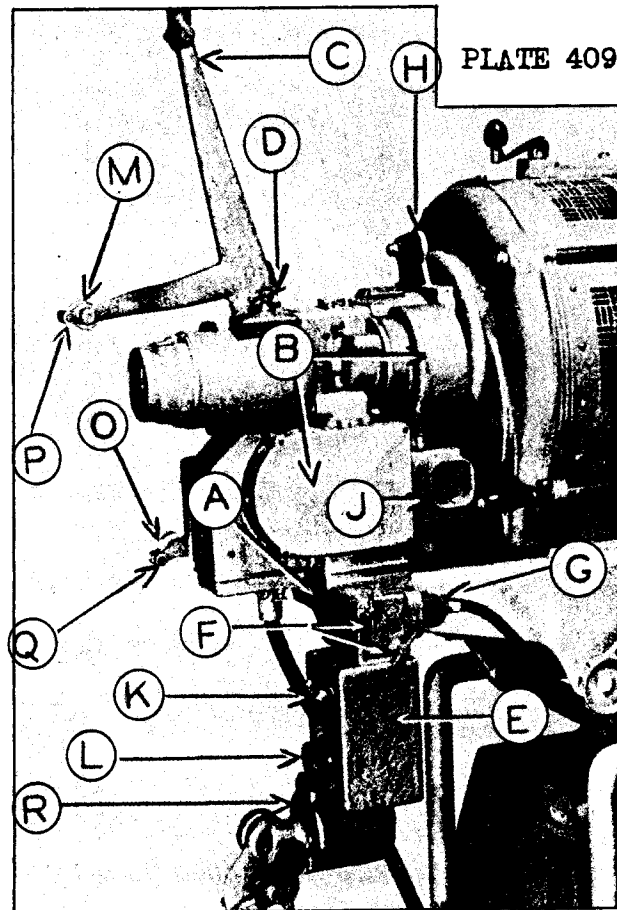

PLATE 409

Check the two knobs (C, Plate 407, two not shown), on either side of the tilt rack, and see that they are tightened down securely. Be sure too, that the top of the stand is reasonably level during the assembly procedure. Leveling it will greatly facilitate mounting the

various parts.

## MOUNTING THE PROJECTOR HEAD

The projector head assembly is composed of a light cone, (mounted at the rear of the projector drive mechanism), and the sound head and film moving mechanism. Examine the projector mounting base A, Plate 408 and D, Plate 408). Beneath this ledge is another knob. This knob holds the projector head on the base. Note that there are two locating pins (D, Plate 408) which

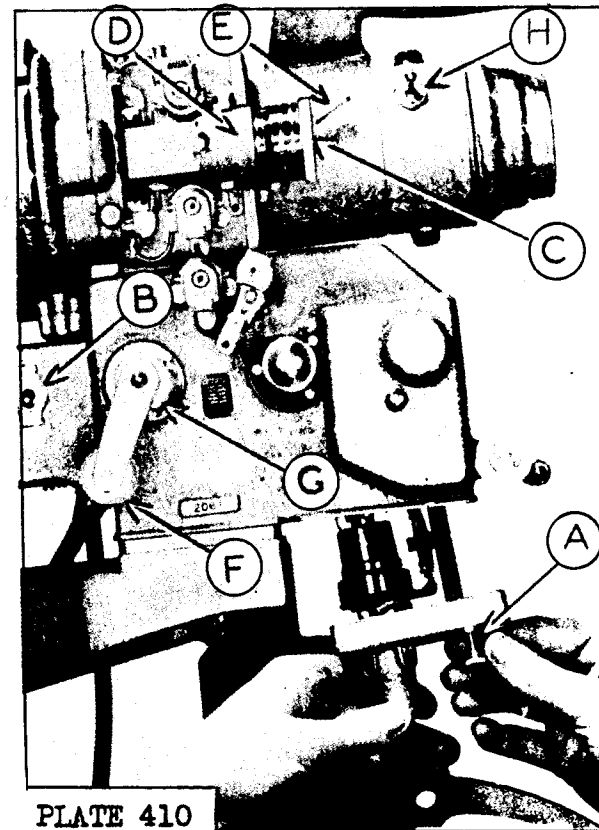

PLATE 410

align the projector head assembly and the base. Place the projector head on the base so that the two locating pins are engaged in the holes in the base of the sound head. Hold the head in place with one hand, and with

the other hand tighten the knob beneath the projector base.

#### MOUNTING THE FEED REEL ARM

Next mount the feed reel arm (C, Plate 409), by the screw (D, Plate 409).

PLATE 411

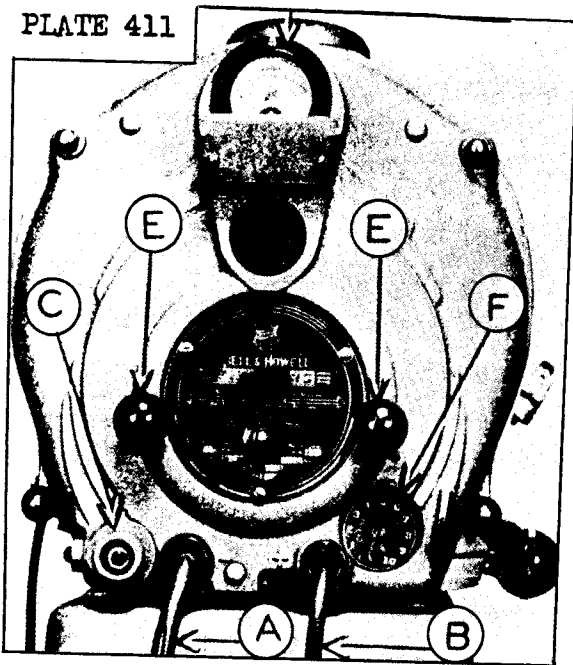

Be sure that the rewind pulley mechanism faces toward the front of the projector. It is almost impossible to mount this arm incorrectly, since both the base, and the reel spindle would indicate its correct location.

#### INSTALLING THE MIRROR REFLECTOR

Refer to Plate 412, Point C. This is the latch which locks the reflector mirror into position. To install the mirror, rotate the knob B, Plate 412, to the right (clockwise) as far as it will go. Rotate knob A, to the left (counter-clockwise) as far as it will go. This will remove the positive and negative carbon holders from their normal position, where they might have inter-

fered with the installation of the mirror.

Examine the large circular frame which will receive the mirror. At the top, and towards the side opposite the operator, you will find a small angular bracket. At the bottom, and toward the same side, is another similar angular retaining bracket.

The mirror, when it is placed in the holder, must be placed behind these two ears.

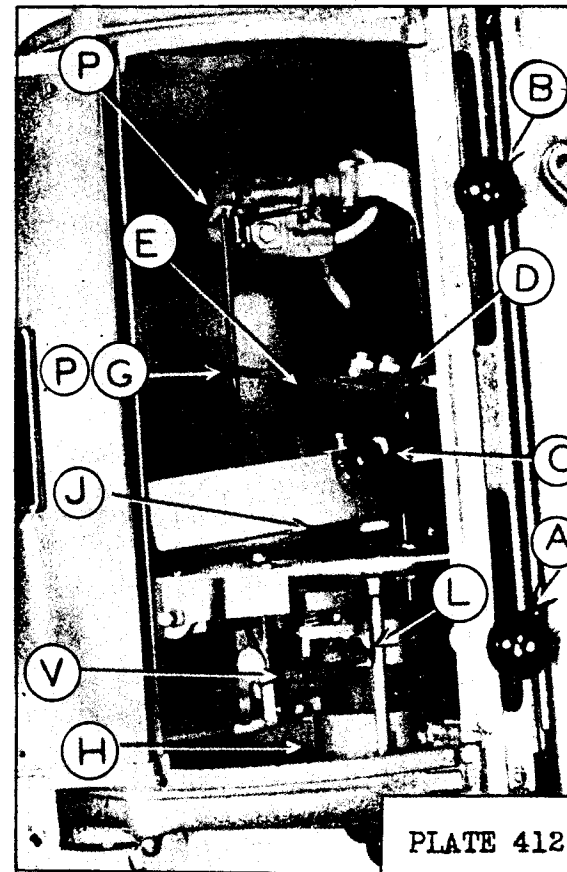

PLATE 412

Grasp the mirror firmly in the right hand, having the Lock C, lifted to its fullest extent; with the left hand, tilt (toward the rear of the lamp) the carbon-

crumb channel (D, Plate 412) at its bottom. This crumb-channel is pivoted and by swinging towards the rear of the lamphouse with the bottom of the channel, the upper edge of it will be re-located in such a way as to clear the mirror during installation.

Tilt the top of the mirror toward the front of the lamphouse and slide it into position within the circular mount. When it is in approximate position, locate the lower edge of the mirror behind the lower retainer bracket. Then, with a rolling motion, and while using back pressure to push the mirror into position against the two "back-pressure" springs, continue the rotation or rolling motion of the mirror, at the same time engaging it behind the top retaining bracket.

When it is located behind both of these brackets and the side by which you are grasping, (toward you) is pointed somewhat forward of its normal location, press the mirror firmly but gently towards the rear of the projector, until it is flush with its holder all around. Then press down the locking lever "C," locking the mirror in place.

With the left hand, reach in between the rear of the mirror holder and the negative electrode mechanism (J, Plate 412) and gently press forward on the mirror, insuring that the mirror is contacting both retaining brackets and the lock. This assures the proper location of the mirror. The flat springs contacting the rear of the mirror will then continue to hold it in proper position. At this time, all finger-prints and other dirt should be very carefully removed from the surface of the mirror in the same way that you would clean a lens, that is, by using a lens cleaning tissue, and if it is particularly dirty, use any lens cleaning fluid that might be available. In the absence of lens cleaning fluid, carbon tetrachloride may be used. After the application of this liquid, another careful wiping with lens tissue is necessary.

#### INSTALLING THE CARBONS

Shipped with the Filmoarc is a cylindrical cardboard mailing tube which contains twenty-five pairs of carbons. Those packed in the center of this tube are the

longer and thicker positive carbons and are so marked on each piece. The negative carbons are placed toward the outside of the tube and are shorter and somewhat thinner than the positive carbons.

Refer again to Plate 411 and locate the "Focusing Control" indicated at C. This control knob can be turned through one complete revolution. The turning of this control moves in unison, both the positive and negative carbon holders and permits the focusing of the crater of the positive carbon (the source of the light) in respect to the mirror. Before installing the carbons, rotate this knob C one complete revolution, then turn it in the reverse direction one-half turn. This will so locate the electrode holders that adjustment may be made in a forward or reverse direction.

Having set the focusing adjustment knob (C, Plate 411) to its mid-position, rotate the positive carbon hand feed knob (B, Plate 412) in a clockwise direction until the shaft upon which the knob B is mounted is located at about 5-1/2 to 5-3/4 on the scale above the slot in which this shaft travels.

Rotate the negative carbon adjustment knob (A, Plate 412) in counter-clockwise direction, until the shaft on this knob is located between 3-1/2 and 4 on the scale above its slot. If you were to rotate both of these knobs to their full extent, you would no longer have the adjustment latitude (as controlled by the knob C, Plate 411) with which to focus the arc at some later time. It therefore is essential that these two adjustment knobs are not turned to the widest apart position but only as far as indicated above.

#### THE POSITIVE CARBON

Leave the two electrode controls in the positions indicated by the above directions. Lift up on the positive carbon lock-lever (A, Plate 413) until this handle is vertical. Insert into the V groove (indicated at C, Plate 413), the square or finished end of the positive carbon. The crater (the end where carbon itself is visible), should be towards the center of the lamphouse, that is, facing the reflected mirror. Move the positive carbon in this V groove (C, Plate 413) in the upper por-

tion of the positive carbon holder, until it is resting against the locating pin B, Plate 413. Holding the carbon lightly and loosely in the groove and against the pin, exerting no definite pressure, move down on the carbon lock-handle A, Plate 414, until the handle is about horizontal. You will feel a back-pressure or tension as the carbon is tightened into position. Do not

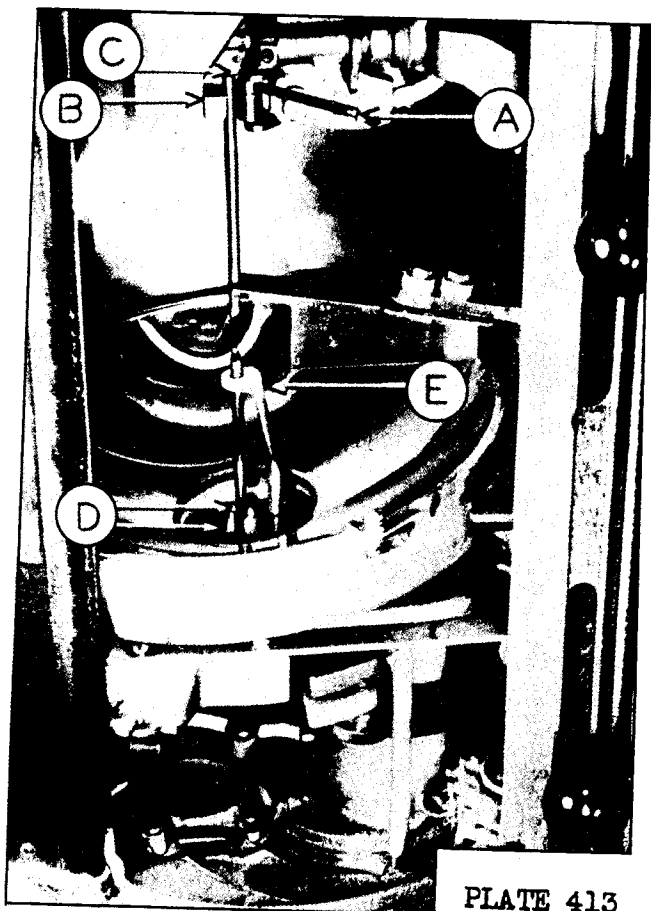

PLATE 413

continue this pressure past the horizontal with the handle; to do so would crush the carbon. The carbon should be firmly in position, but not jammed. A little prac-

tice inserting and removing the carbon from this holder will make you adept.

#### THE NEGATIVE CARBON

Do not move either the negative or positive holder, and proceed to the installation of the negative carbon. Unscrewing (turning counter-clockwise) the Bakelite knob (A, Plate 414), will open the jaws, D, Plate 413



PLATE 414

which clamp and hold the negative carbon. The screw, A, Plate 414, should be turned counter-clockwise only one revolution, or enough to open the jaw sufficiently to receive the carbon.

Lay in the negative carbon so that it lines up correctly and rests on the negative carbon guide (E, Plate 413). Hold it in this position, with a space of about

1/4" from the pointed tip of the negative to the crater in the positive carbon. Tighten firmly on the knob, A, Plate 414. Again let us caution you against tightening this knob too tightly; it is quite easy to crush the carbon. Again a little practice will be of great service in familiarizing you with the amount of tension required.

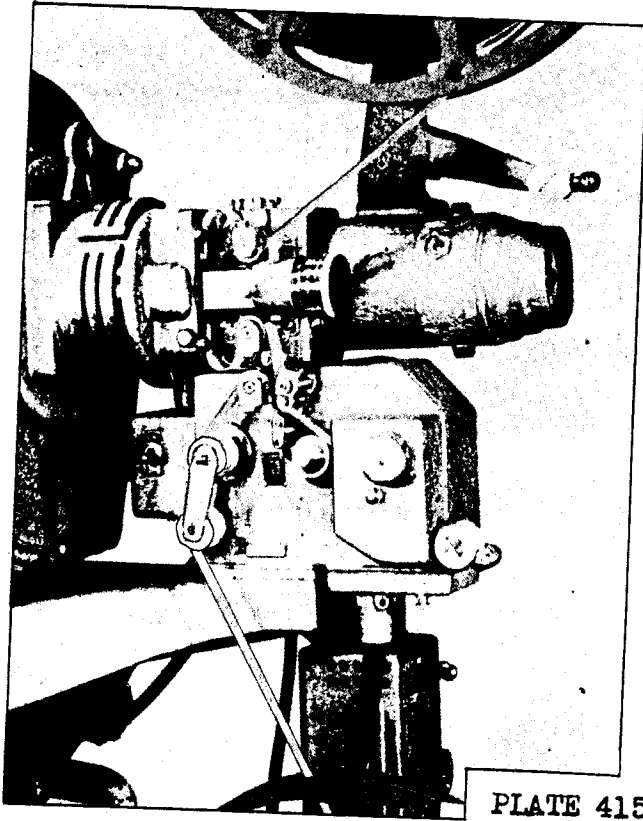

PLATE 415

## CARBON-FEED MOTOR

After the arc has been running for a few moments, carefully examine the target (J, Plate 408) and see whether or not the distance between the electrodes is changing, or the location of either of the electrodes is changing. If you find that the gap is becoming smaller,

the carbon-feed motor is feeding the carbons together too rapidly. To slow this feed motor, turn the motor controller (F, Plate 411) in a counter-clockwise direction. Immediately also correct by operating Knobs A, and B, Plate 412, the location of the two carbons. Again watch after a few minutes of operation to check the speed adjustment of this carbon-feed motor. If it should open the gap or close the gap, correct again by speeding the carbon-feed motor up, turning the knob in a clockwise direction or decreasing the speed by turning it in a counter-clockwise direction. This should be watched carefully until you learn to correlate, from experience, the proper adjustment of this carbon-feed motor, with the indicated line voltage and with the current flowing at the arc.

## ADJUSTING THE ARC

Check the location and width of the arc gap by referring to the target (J, Plate 408). Because the arc flame and electrodes are reflected by the small mirror (K, Plate 408) the front, positive carbon will be reflected at the rear of the target, J, and the rear, negative carbon will be reflected at the front of the target, J.

The reflection of the intensely white spot representing the crater in the positive carbon should be evenly aligned with the rear of the two parallel lines on the target, J.

If you are now sure that the positive carbon is properly focused on the rear of the two lines on target, J, and that the space between the carbons is correct as indicated on the target, J, examine the reading of the ammeter (D, Plate 411). This should read as near to 30 amperes as possible. If the reading is less than 30 amperes, turn the line voltage adjustment knob on the rectifier (L, Plate 408) in a clockwise direction. The contact arm on the rear of this control knob, L, will contact only one point on the back of this switch at one time. There is a definite space between each point. If this adjustment is made with a quick twist, you will, without having the arc "go out," engage the next contact point. If this movement is not made quickly—due to the space between the contact points on the

switch—the arc flame will go out and have to be re-struck.

FOR VERY HIGH OR LOW LINE VOLTAGES

If rotating the knobs does not give necessary control, additional control is available by use of the three

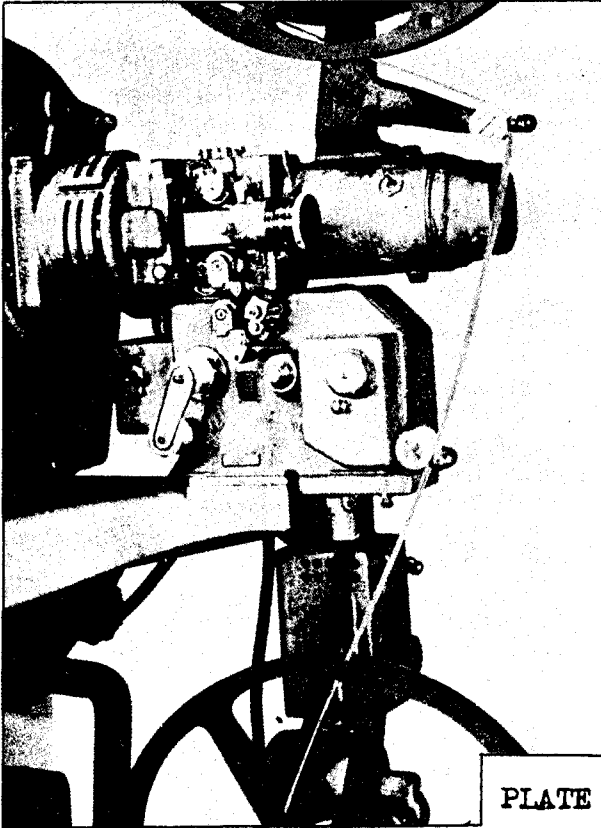
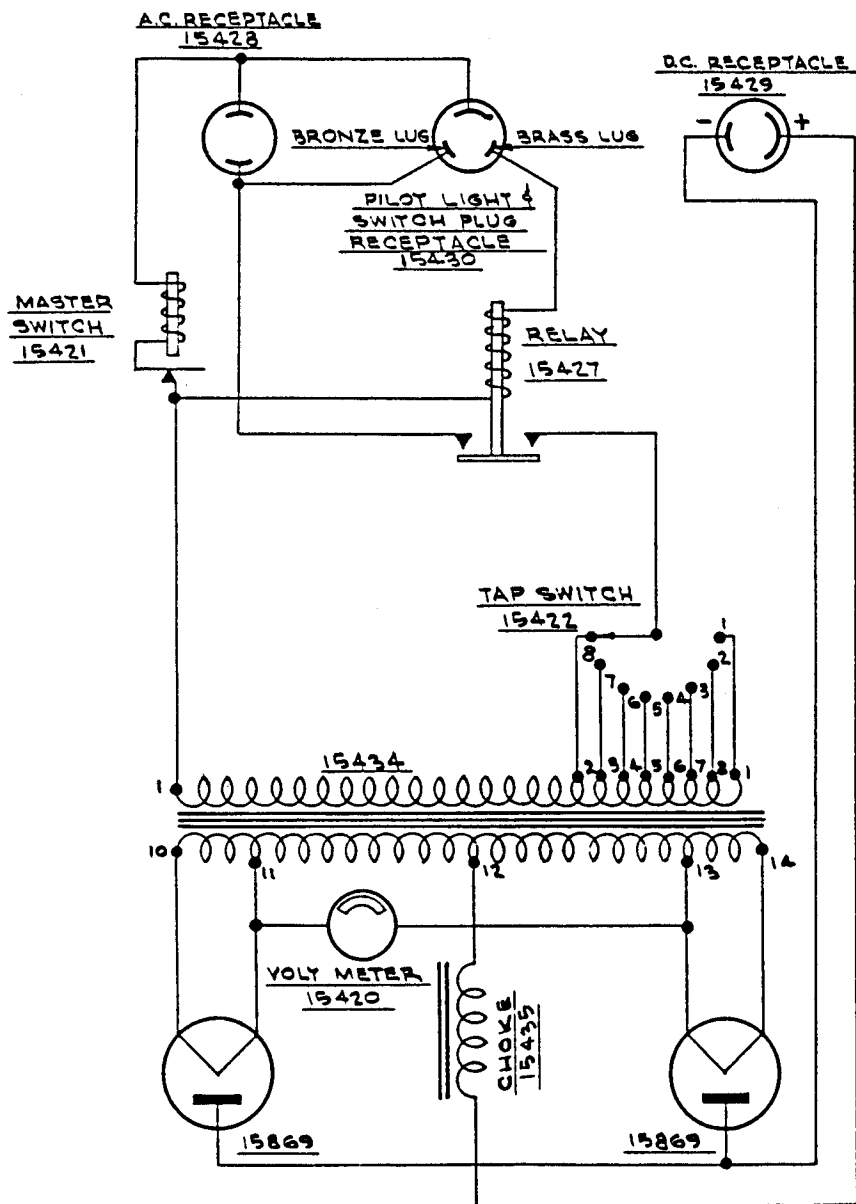
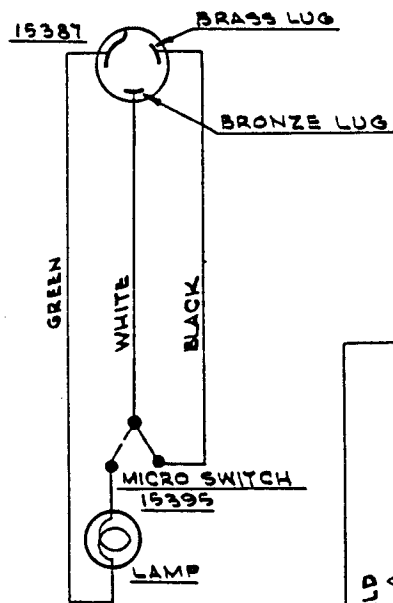

PLATE 417

taps to be found on the terminal strip inside the rectifier to the lower left. The tap farthest from the front terminal is for line voltages ranging between 115 and 130 volts. The center tap is for voltage ranging from 105 to 115 volts. The tap nearest the front panel is for voltages between 95 and 105 volts. Ordinarily the center tap is the one most used.



RECTIFIER CIRCUIT



PILOT LIGHT & SWITCH CIRCUIT IN LAMPHOUSE

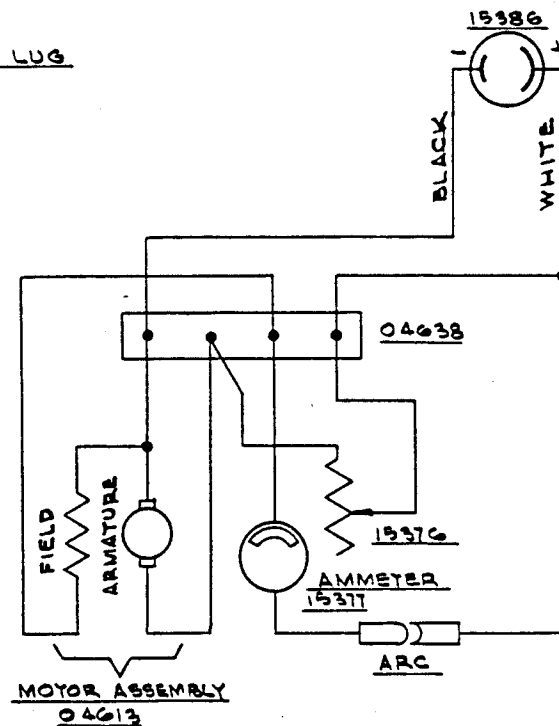

LAMP CIRCUIT

SERVICE DATA	
WIRING DIAGRAM FILMOARC LAMP & RECTIFIER	
DESIGN 140 FILMOARC	MODEL R
DRAWN E.G.P.	APVD. DATE 4-21-48



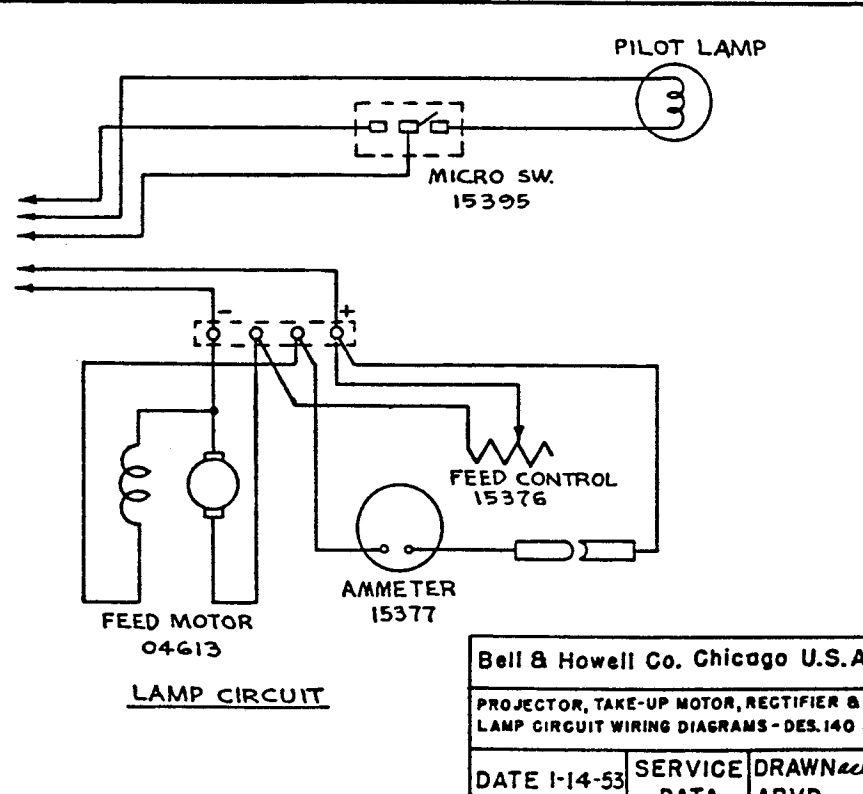
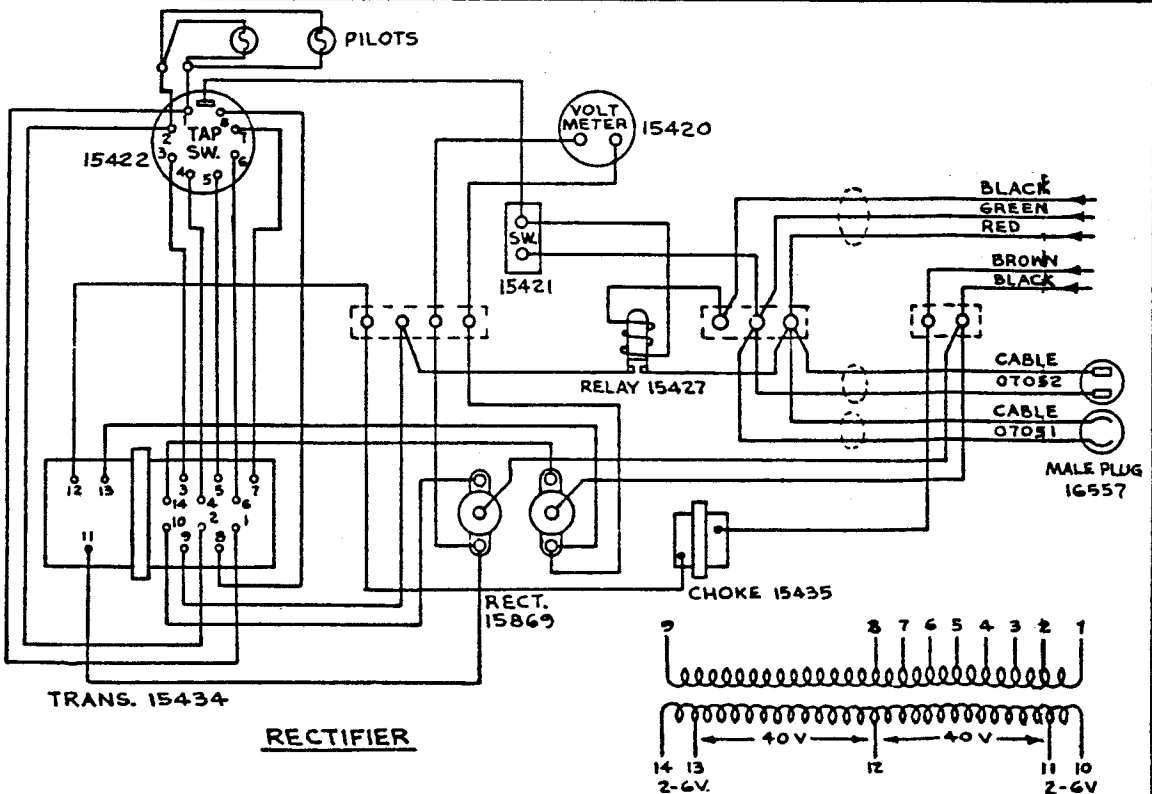
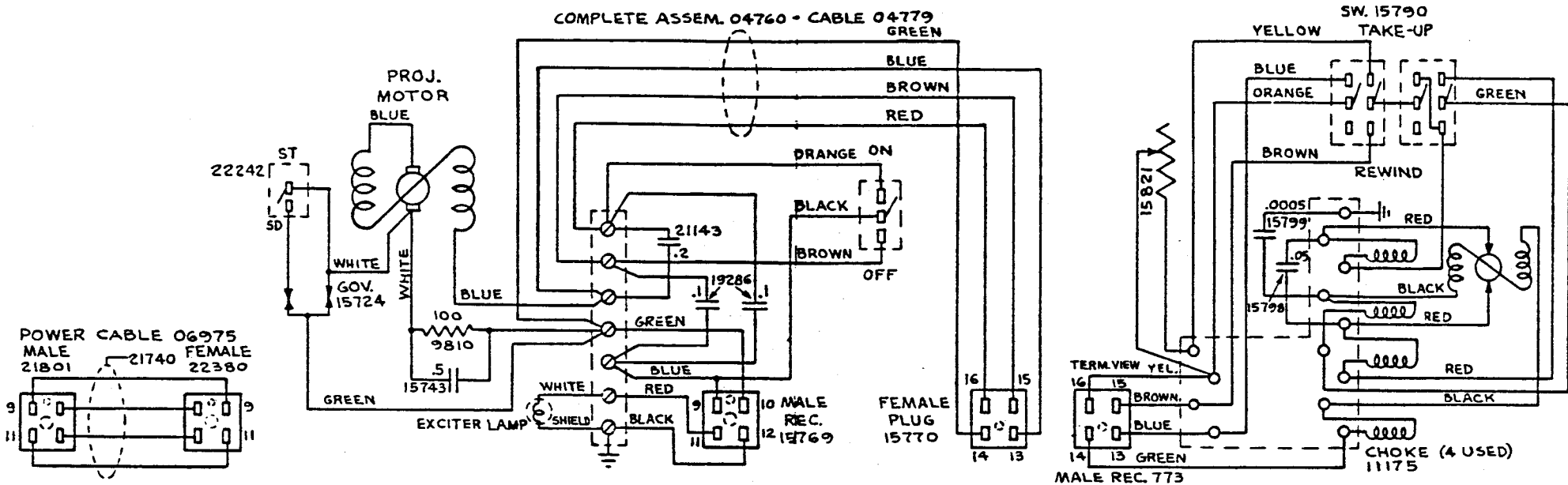

Bell & Howell Co. Chicago U.S.A.

PROJECTOR, TAKE-UP MOTOR, RECTIFIER & LAMP CIRCUIT WIRING DIAGRAMS - DES.140 U

DATE 1-14-53	SERVICE DATA	DRAWN BY APVD.
--------------	--------------	----------------

SWITCH OPEN FOR SILENT AND  
CLOSED FOR SOUND SPEEDS

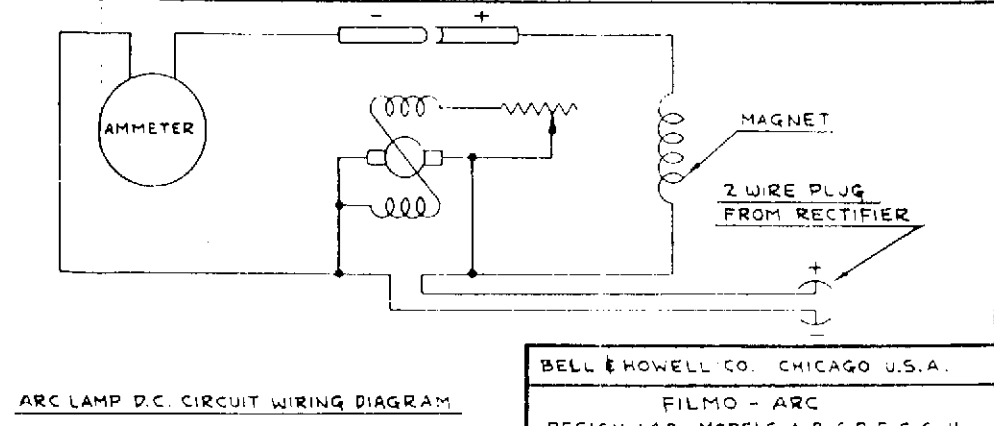
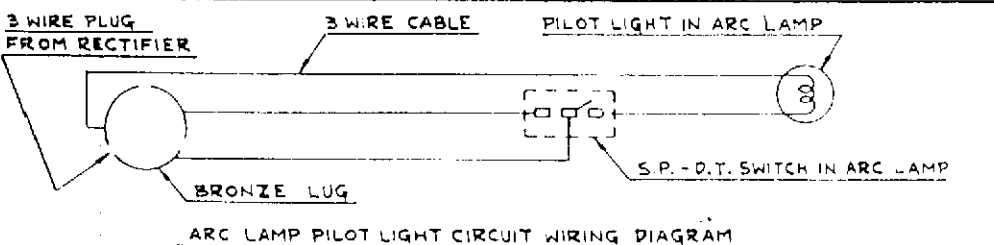
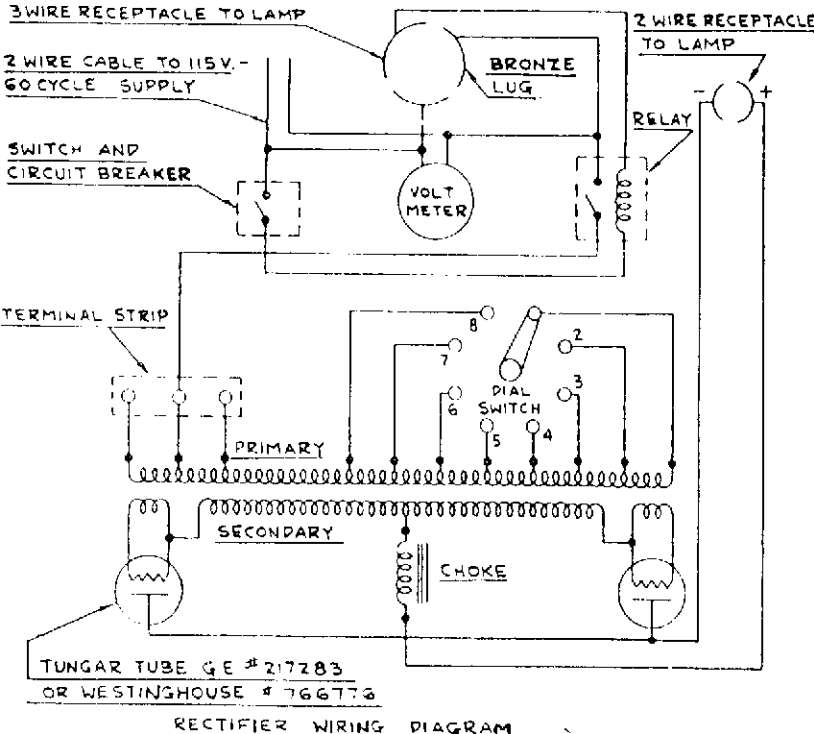
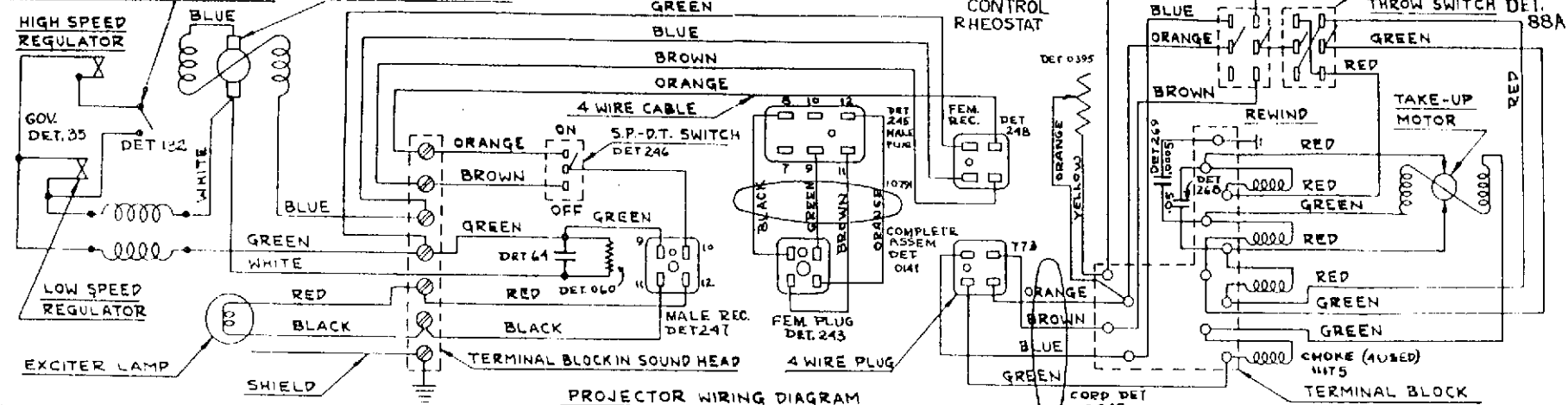

BELL & HOWELL CO. CHICAGO U.S.A.  
 FILMO - ARC  
 DESIGN 140 MODELS A-B-C-D-E-F-G-H  
 1-28-38 SERVICE DATA DRAWN P.C.R. APVD.

F5

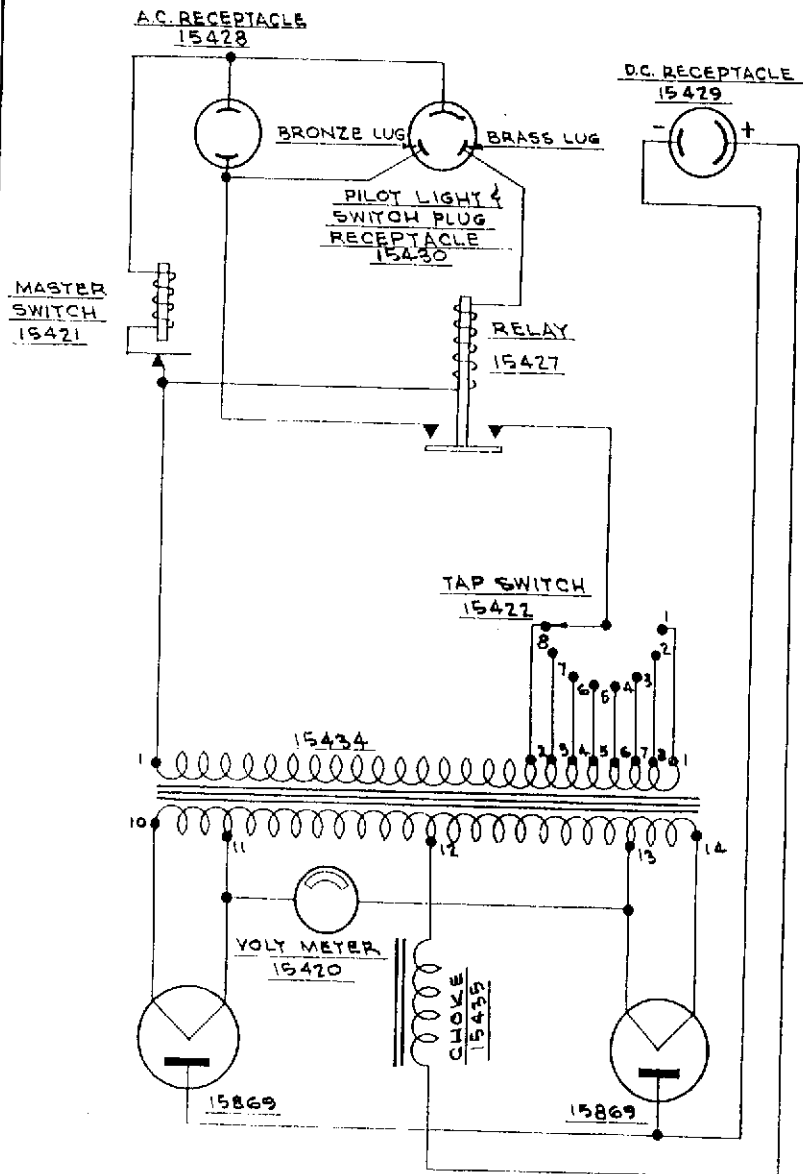

RECTIFIER CIRCUIT

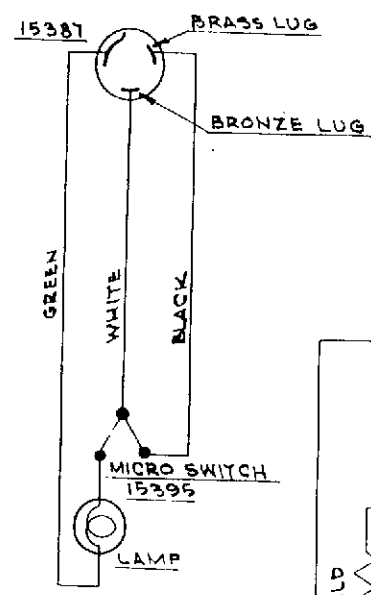

PILOT LIGHT & SWITCH CIRCUIT IN LAMPHOUSE

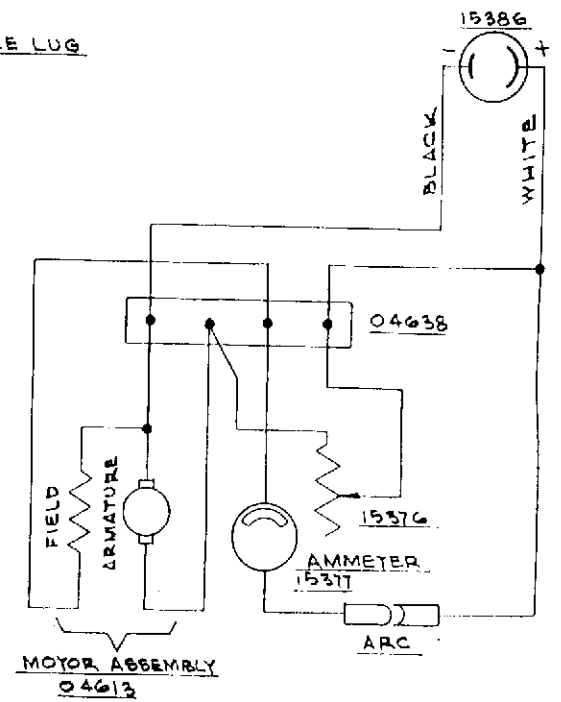

LAMP CIRCUIT

SERVICE DATA	
WIRING DIAGRAM FILMOARC LAMP & RECTIFIER	
DESIGN 140 FILMOARC	MODEL R
DRAWN E.G.P.	APVD. DATE 4-21-48

F-6 SHEET-A

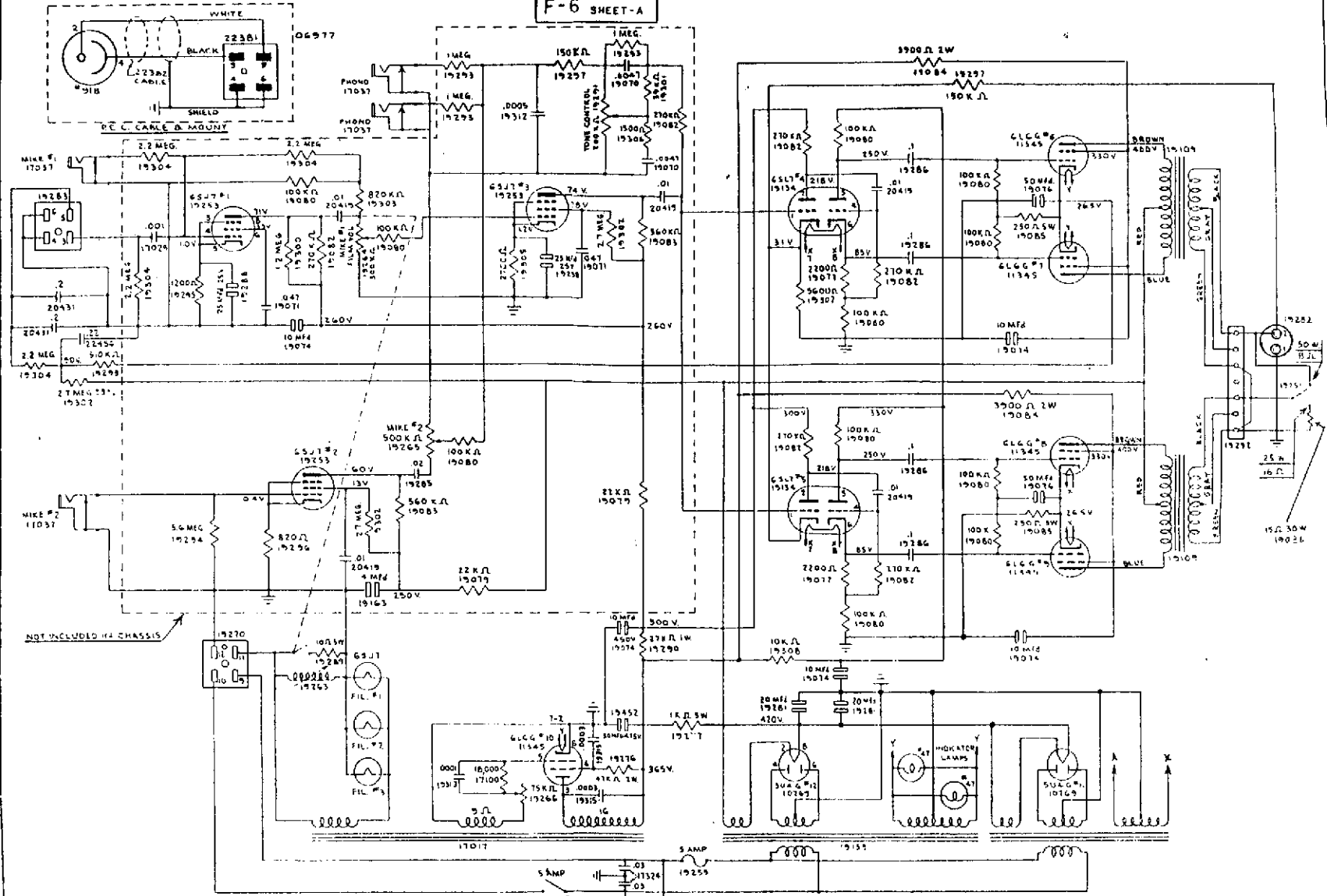

SENSITIVITY AT 117 V LINE VOL ON FULL TONE CONT BASS		FREQUENCY RESPONSE THRU FILM CHANNEL		
FILM CHANNEL THRU 20 MEG TO PTC CATHODE 152 V		FREQUENCY	100% TONE CONTROL	INPUT VOLTS DBB
MIC #1 DIRECT TO JACK	0.1V	70	6.0	20.5
MIC #2 DIRECT TO JACK	0.04V	100	3.5	18.0
PHONO DIRECT TO JACK	1V	500	8.0	13.0
MEASUREMENT MADE AT 1000 ~ 8 Ω RES LOAD		1M	9.0	9.5
OUTPUT VOLTAGE 13.8 V		3M	9.0	1.5
POWER OUTPUT AT 117 V LINE 400 ~ 8 Ω LOAD		5M	9.0	0
45 WATTS AT 5%		7M	9.0	1.5
		10M	9.5	5.5

WIRE COLOR CODE			
WHITE	GROUND	BLU	PLATE
YELLOW	CATHODE	BRO	SCREEN
RED	B+	BLK	AC
GREEN	GRID	BLK & WHITE	B-

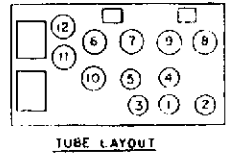

Bell & Howell Co. Chicago U.S.A.  
 50W AMPLIFIER WIRING DIAGRAM FOR  
 DESIGNS 140 S.T.U. 1063291  
 DATE 3-12-52 SERVICE DATA DRAWN BY APVJ

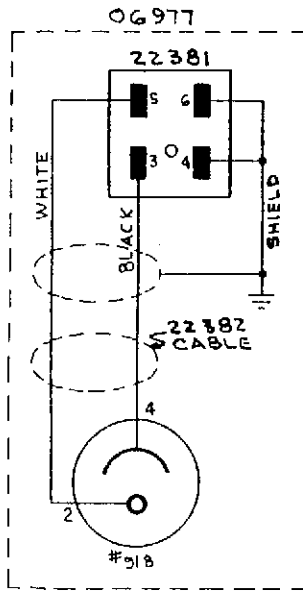

P.E.C. CABLE & MOUNT

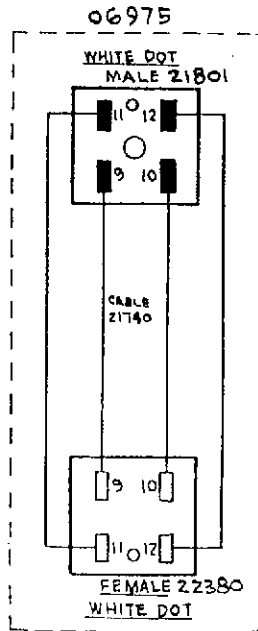

POWER CABLE TO PROJECTOR

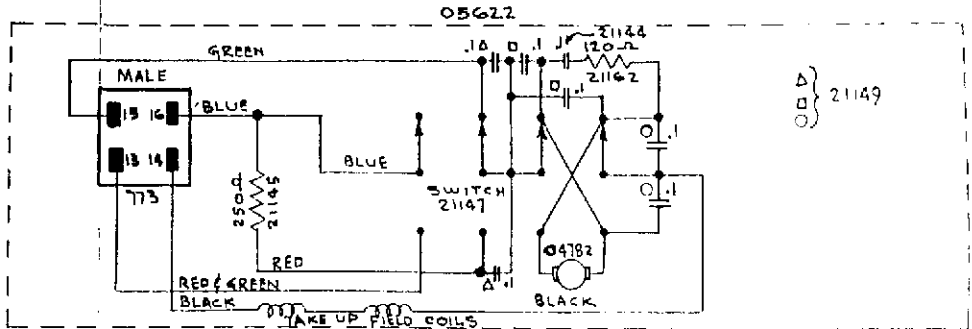

TAKE UP MOTOR WIRING

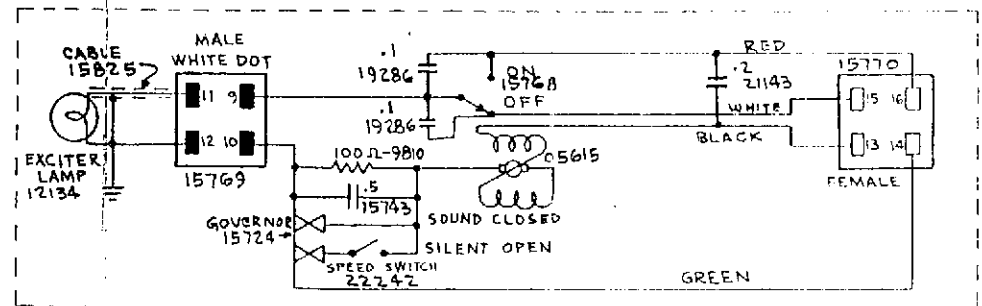

PROJECTOR WIRING

PARTS ON THIS SHEET NOT INCLUDED IN AMPLIFIER CHASSIS

Bell & Howell Co. Chicago U S A.		
PROJECTOR & TAKE-UP MOTOR WIRING DIAGRAM & CABLES FOR DESIGNS 140 S.T.U.		
DATE 3-12-52	SERVICE DATA	DRAWN BY APVD. ✓

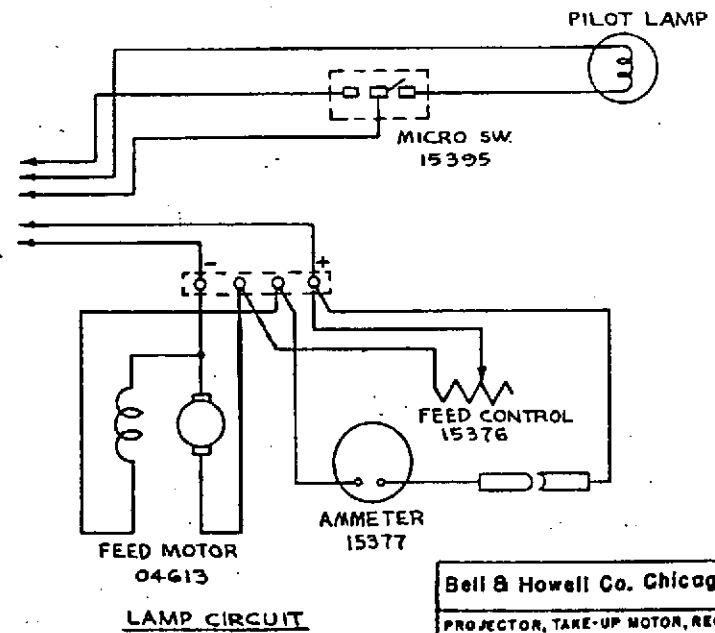
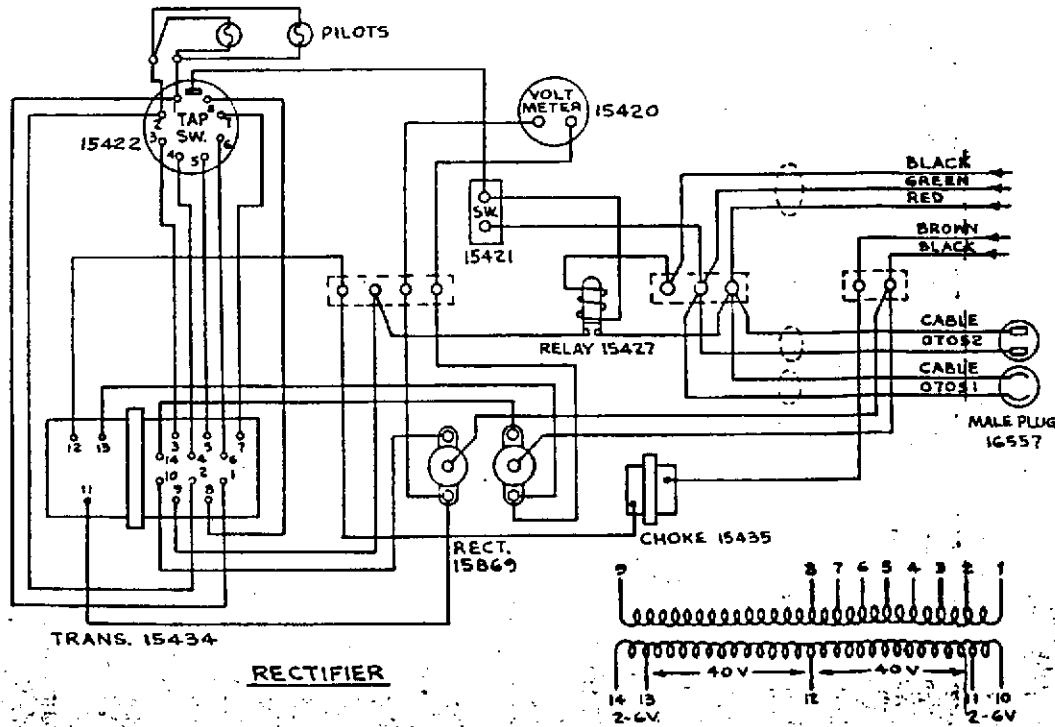
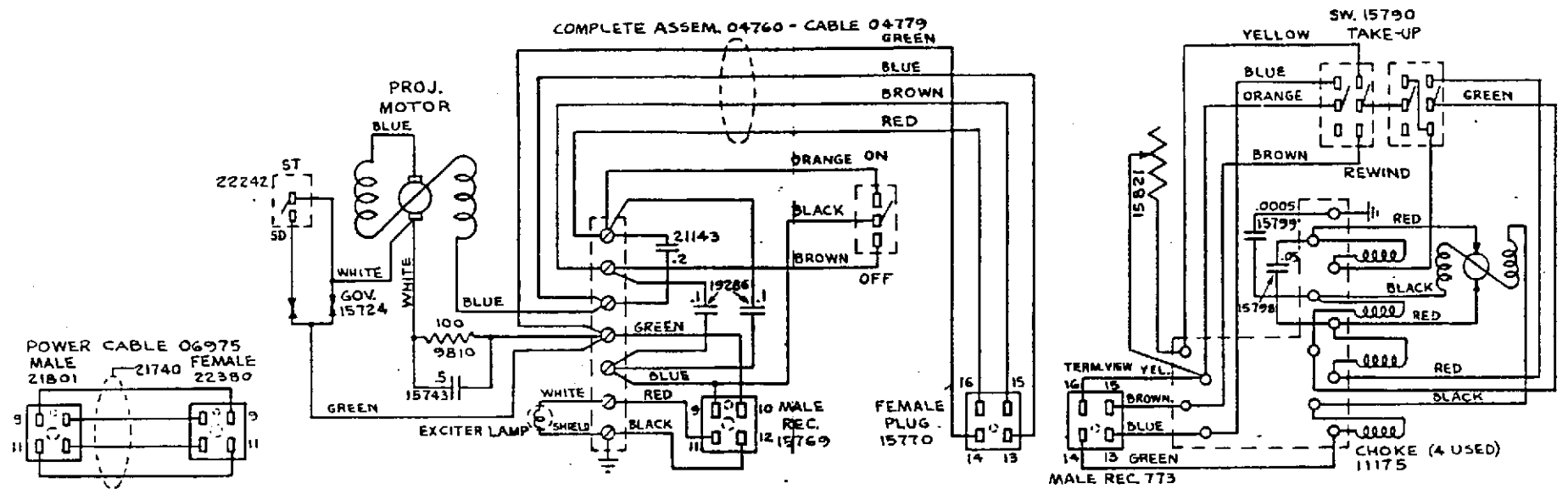

Bell & Howell Co. Chicago U.S.A.

PROJECTOR, TAKE-UP MOTOR, RECTIFIER & LAMP CIRCUIT WIRING DIAGRAMS - DES. 140 U

DATE 1-14-53	SERVICE DATA	DRAWN APVD
--------------	--------------	------------

SECTION F  
DESIGN 140-FILMOARC

GENERAL INFORMATION.

On page F2 will be found the projector and arc lamp - DC current - wiring diagrams. The Bell & Howell Filmoarc uses the Design 130 amplifier, information for which may be found under Section "D" of this manual.

Be sure the speaker selector switch in the rear of the amplifier is set to the "Single Speaker" position for single speaker and "Dual Speaker" position when two speakers are being used.

When ordering parts be sure to use the work "DETAIL" and number wherever shown.

Lamp house and rectifier parts have not been given a Bell & Howell number; therefore, it will be necessary to order them by description.

The Instructions and Manual of Operation for the Filmoarc thoroughly cover the projector lamp housing and rectifier.

F4

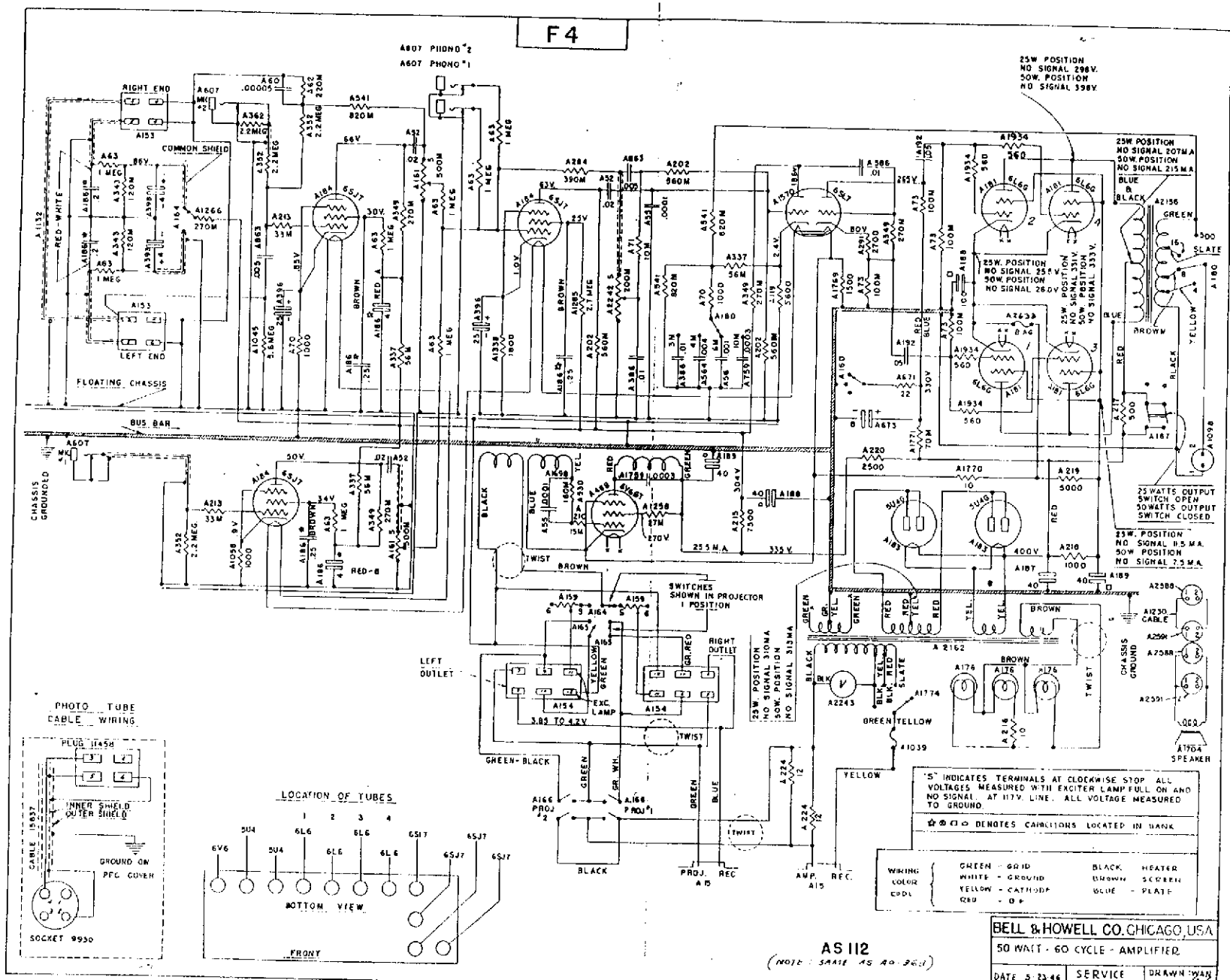

25W POSITION  
NO SIGNAL 298V  
50W POSITION  
NO SIGNAL 338V

25W POSITION  
NO SIGNAL 207MA  
50W POSITION  
NO SIGNAL 215MA  
BLUE  
&  
BLACK

25W POSITION  
NO SIGNAL 25.4V  
50W POSITION  
NO SIGNAL 31V  
50W POSITION  
NO SIGNAL 33V  
TO SIGNAL 33V

25 WATTS OUTPUT  
SWITCH OPEN  
50 WATTS OUTPUT  
SWITCH CLOSED

25W POSITION  
NO SIGNAL 1.5 MA  
50W POSITION  
NO SIGNAL 2.5 MA

\*S\* INDICATES TERMINALS AT CLOCKWISE STOP ALL VOLTAGES MEASURED WITH EXCITER LAMP FULL ON AND NO SIGNAL AT HTV LINE. ALL VOLTAGE MEASURED TO GROUND  
\*□□□\* DENOTES CAPILLARIES LOCATED IN BANK

WIRING COLOR CODE  
GREEN - GRID  
WHITE - GROUND  
YELLOW - CATHODE  
RED - O +  
BLACK - HEATER  
BROWN - SCREEN  
BLUE - PLATE

BELL & HOWELL CO. CHICAGO, U.S.A.

50 WATT - 60 CYCLE - AMPLIFIER

DATE 5-23-46 SERVICE DATA DRAWN: WAN APVD: [Signature]

AS 112

(NOTE: SAME AS AS 30.1)

LOCATION OF TUBES

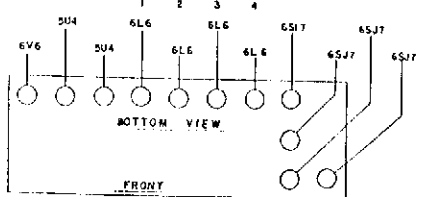
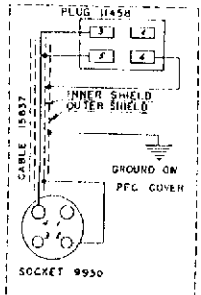
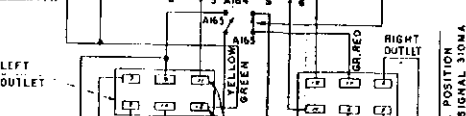

PHOTO TUBE CABLE WIRING



SWITCHES SHOWN IN PROJECTOR POSITION



\*S\* INDICATES TERMINALS AT CLOCKWISE STOP ALL VOLTAGES MEASURED WITH EXCITER LAMP FULL ON AND NO SIGNAL AT HTV LINE. ALL VOLTAGE MEASURED TO GROUND  
\*□□□\* DENOTES CAPILLARIES LOCATED IN BANK

WIRING COLOR CODE  
GREEN - GRID  
WHITE - GROUND  
YELLOW - CATHODE  
RED - O +  
BLACK - HEATER  
BROWN - SCREEN  
BLUE - PLATE

BELL & HOWELL CO. CHICAGO, U.S.A.

50 WATT - 60 CYCLE - AMPLIFIER

DATE 5-23-46 SERVICE DATA DRAWN: WAN APVD: [Signature]



DESIGN 130 and 140 - AMPLIFIER NO. 03600

GENERAL INFORMATION.

This amplifier differs from other Design 130 types in that all three input tubes as well as the phase inverter have their filaments connected in series and are operated by the current flowing in the output tube cathode circuit.

Frequency characteristics of the amplifier may be altered by means of a tapped control on the rear of the amplifier.

Two microphone inputs are featured, one of which is under separate control. The second is mixed at a fixed level with the photocell input. Control is by the main film volume control.

Two phonograph inputs are provided, neither of which has a volume control. Phonovolume should be controlled by means of the volume control on the phonograph.

The output transformer has a tapped secondary controlled by means of a switch on the rear of amplifier. The permanent-magnet type speaker has an impedance of 16 ohms.

The power output is 25 watts with a single speaker and 50 watts with dual speakers.

See General Information 130-C, par. 1.

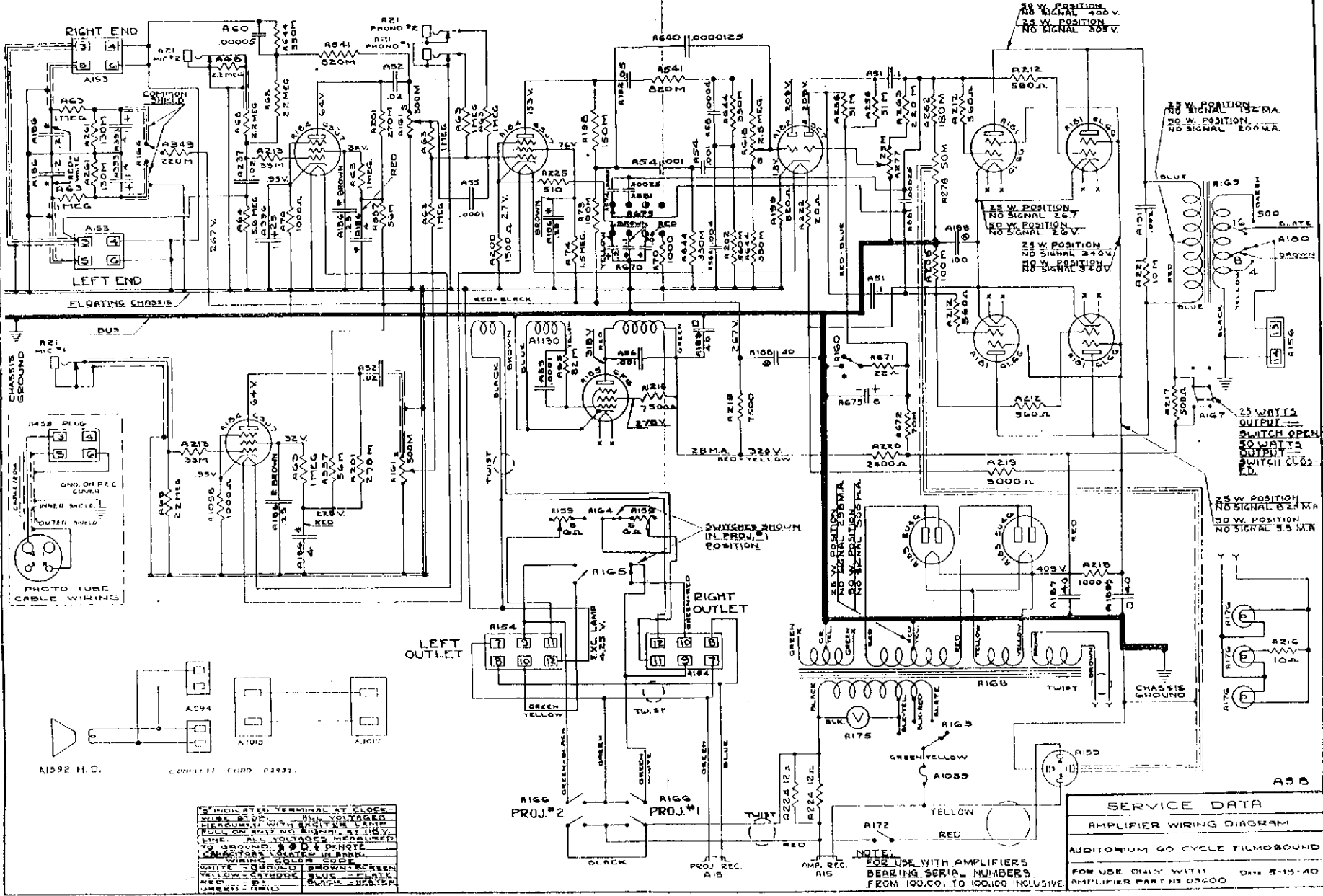

INDICATED TERMINAL AT CLOCK  
 BLUE - 200V  
 GREEN - 250V  
 RED - 300V  
 YELLOW - 350V  
 BROWN - 400V  
 BLACK - 450V  
 WHITE - 500V  
 BLUE - 550V  
 GREEN - 600V  
 RED - 650V  
 YELLOW - 700V  
 BROWN - 750V  
 BLACK - 800V  
 WHITE - 850V  
 BLUE - 900V  
 GREEN - 950V  
 RED - 1000V  
 YELLOW - 1050V  
 BROWN - 1100V  
 BLACK - 1150V  
 WHITE - 1200V  
 BLUE - 1250V  
 GREEN - 1300V  
 RED - 1350V  
 YELLOW - 1400V  
 BROWN - 1450V  
 BLACK - 1500V  
 WHITE - 1550V  
 BLUE - 1600V  
 GREEN - 1650V  
 RED - 1700V  
 YELLOW - 1750V  
 BROWN - 1800V  
 BLACK - 1850V  
 WHITE - 1900V  
 BLUE - 1950V  
 GREEN - 2000V  
 RED - 2050V  
 YELLOW - 2100V  
 BROWN - 2150V  
 BLACK - 2200V  
 WHITE - 2250V  
 BLUE - 2300V  
 GREEN - 2350V  
 RED - 2400V  
 YELLOW - 2450V  
 BROWN - 2500V  
 BLACK - 2550V  
 WHITE - 2600V  
 BLUE - 2650V  
 GREEN - 2700V  
 RED - 2750V  
 YELLOW - 2800V  
 BROWN - 2850V  
 BLACK - 2900V  
 WHITE - 2950V  
 BLUE - 3000V  
 GREEN - 3050V  
 RED - 3100V  
 YELLOW - 3150V  
 BROWN - 3200V  
 BLACK - 3250V  
 WHITE - 3300V  
 BLUE - 3350V  
 GREEN - 3400V  
 RED - 3450V  
 YELLOW - 3500V  
 BROWN - 3550V  
 BLACK - 3600V  
 WHITE - 3650V  
 BLUE - 3700V  
 GREEN - 3750V  
 RED - 3800V  
 YELLOW - 3850V  
 BROWN - 3900V  
 BLACK - 3950V  
 WHITE - 4000V  
 BLUE - 4050V  
 GREEN - 4100V  
 RED - 4150V  
 YELLOW - 4200V  
 BROWN - 4250V  
 BLACK - 4300V  
 WHITE - 4350V  
 BLUE - 4400V  
 GREEN - 4450V  
 RED - 4500V  
 YELLOW - 4550V  
 BROWN - 4600V  
 BLACK - 4650V  
 WHITE - 4700V  
 BLUE - 4750V  
 GREEN - 4800V  
 RED - 4850V  
 YELLOW - 4900V  
 BROWN - 4950V  
 BLACK - 5000V

SERVICE DATA	
AMPLIFIER WIRING DIAGRAM	
AUDITORIUM 60 CYCLE FILM SOUND	
FOR USE ONLY WITH DATE 5-15-40	
AMPLIFIER PART NO. 02400	