

Film-Tech

The information contained in this Adobe Acrobat pdf file is provided at your own risk and good judgment.

These manuals are designed to facilitate the exchange of information related to cinema projection and film handling, with no warranties nor obligations from the authors, for qualified field service engineers.

If you are not a qualified technician, please make no adjustments to anything you may read about in these Adobe manual downloads

www.film-tech.com



Property of Shaker Theatre

Bauer

ERSATZTEILE / SPARE PARTS

ohne Filmweg

without film path

Universal-Projektor

Universal Projector

U2

EUGEN BAUER GMBH STUTTGART-UNTERTÜRKHEIM

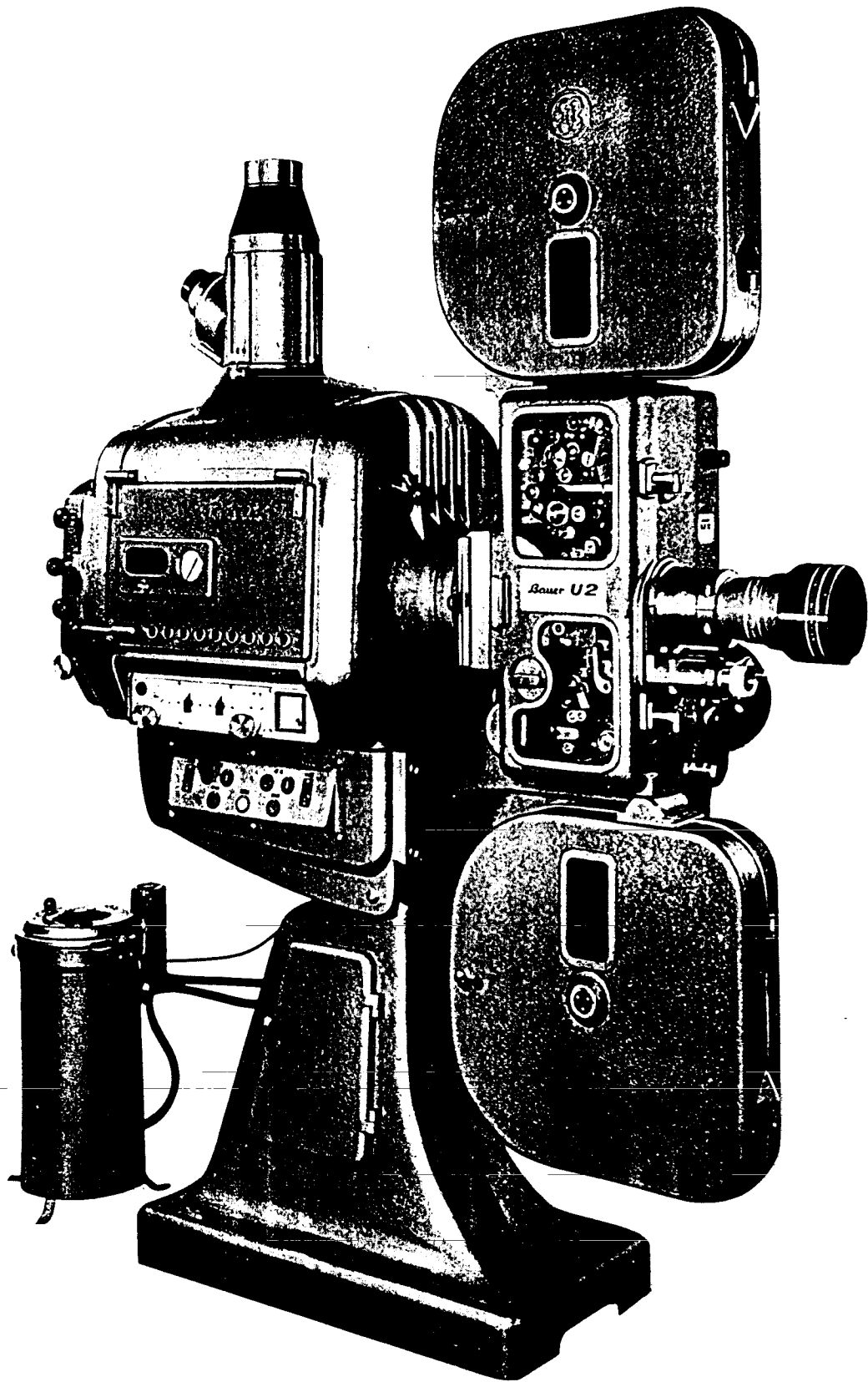

BAUER U2-Projektor mit Hochstromlampe und Wasserzirkulator
BAUER U2-Projektor with high-current arc lamp and water circulator

Lfd. Nr.	Stückzahl	ERSATZTEIL-LISTE	SPARE PART LIST	Bestell-Nr.
No.	qt.	Werk Innenteile	Interiour parts for mechanism	Order No.
1		Werk: (komplett)	Mechanism	UW 2 GE 6/2 Z
2	7	Schrauben für oberen Werkdeckel	screws for upper mechanism cover	
3	5	Schrauben Innen-6-Kant	hexagon socket screws	M 6 × 35 DIN 912 ⁸³³
4	1	Schraube f. oberen Werkdeckel	hexagon socket screw	M 6 × 25 DIN 912 ⁸³⁴
5	1	Schraube Innen-6-Kant	hexagon socket screw	M 6 × 40 DIN 912 ⁸³⁴
6	7	Schrauben für unteren Werkdeckel	screws for lower mechanism cover	
7	4	Schrauben Innen-6-Kant	hexagon socket screws	M 6 × 25 DIN 912 ⁸³⁴
8	2	Schrauben f. unteren Werkdeckel	hexagon socket screws	M 6 × 35 DIN 912 ⁸³³
9	1	Schraube Innen-6-Kant	hexagon socket screw	M 6 × 40 DIN 912 ⁸³³
10	1	Zylinderstift, Anschlag für Drehgehäuse	cylindrical pin	6 × 18 DIN 7
11	1	Verschußstopfen	filler cap	UW 2 MF 54/1 X
12	1	Kreuzlagerflansch	cross bearing flange	UW 2 FL 4/1 X
13	4	Innen-6-Kantschrauben	hexagon socket screws	M 6 × 12 DIN 912 ⁸³³
14	1	Ölfanghülse	oil catcher	UW 2 MH 8/1 X
15	1	Kreuzgetriebe kpl.	Cross gear compl.	UW 2 GT 1/1 Z
16	1	Führungsstück	guide piece	UW 2 MF 52/1 X
17	2	Innen-6-Kantschrauben	hexagon socket screws	M 6 × 18 DIN 912
18	2	Gleitbolzen	sliding pins	UW 2 BO 19/1 X
19	2	Federn	springs	UW 2 FS 12/2 X
20	2	Ansatzschrauben	coupling screws	UW 2 SR 7/1 X
21	2	Gewindestifte	threaded pins	M 5 × 15 DIN 551
22	1	Ritzellager kpl.	pinion bearing, compl.	UW 2 LG 9/1 Z
23	2	Innen-6-Kantschrauben	hexagon socket screws	M 8 × 25 DIN 912
24	1	Ritzelwelle mit Zahnrad	pinion shaft with gear	UW 2 AC 24/1 Z
25	1	Zahnrad allein	gear only	UW 2 ZR 34/1 X
26	1	Spannstift	clamping pin	3 × 24 DIN 1481
27	1	Scheibe	washer	UW 2 MS 7/1 X
28		Ausgleichscheiben nach Bedarf	washers, as required	MS 29/1 . . . X
29	1	Seeger-Außensicherung	spring clip	15 × 1 DIN 471
30	1	Bildstell-Lager	bearing for framing	UW 2 LG 12/1 X
31	3	Innen-6-Kantschrauben	hexagon socket screws	M 6 × 12 DIN 912 ⁸³³
32	1	Bildstellachse mit Zahnrad - Mitnehmer	Framing shaft	UW 2 AC 31/1 Z
33	1	Spannstift für Zahnrad auf Pos. 32	clamping pin	3,5 × 18 DIN 1481
34	1	Spannstift für Mitnehmer	clamping pin	3,5 × 20 DIN 1481
35	1	Scheibe	washer	UW 2 MS 9/1 X
36		Ausgleichscheiben nach Bedarf	washers, as required	MS 26/1 . . . X
37	1	Seeger-Außensicherung	spring clip	12 × 1 DIN 471
38	1	Bildstellrohr	framing pipe	UW 2 RR 6/1 X
39	2	Linsenschrauben	flat head screws	M 4 × 5 DIN 85 ⁸⁴³
40	1	Rastfeder	lock spring	UW 2 FB 7/1 X
41	2	Linsenschrauben	flat head screws	M 3 × 4 DIN 85 ⁸⁴³
42	1	Bildstellgriff	framing knob	UW 2 HG 5/1 Z
43	1	Vertikalwelle	Vertical shaft	UW 2 AC 6/2 Z
44	7	Innen-6-Kantschrauben	hexagon socket screws	M 8 × 25 DIN 912
45	1	Lagerbock	pillow block	UW 2 LG 2/1 X
46	2	Gewindestifte	threaded pins	AM 8 × 10 DIN 913 ⁸³¹
47	1	Führungsstange	guide rod	UW 2 AC 7/1 X
48	1	Führungsstange	guide rod	UW 2 AC 7/2 X
49	1	Schnecke	worm	UW 2 ZR 19/1 X
50	1	Spannstift in Pos.	clamping pin	3,5 × 24 DIN 1481
51	1	Spannstift 49	clamping pin	2 × 24 DIN 1481
52	1	Deckscheibe	cover disc	MBMS 3/2 X
53	1	Kugellager	ball bearing	KL 4/1 Z
54	1	Federführung	spring guide	UW 2 MF 27/1 X
55	1	Druckfeder	pressure spring	UW 2 FS 3/1 X
56	1	Fliehkraftregler	centrifugal governor	UW 2 MF 26/1 X
57	1	Scheibenfeder	spring washer	KE 1/1 . . . X
58	6	Kugeln	balls	13-III DIN 5401
59	1	Kugelring	ball ring	UW 2 MR 6/1 X
60	1	Spannstift	clamping pin	3,5 × 28 DIN 1481
61	1	Blendenrad	shutter gear	UW 2 ZR 18/1 Z

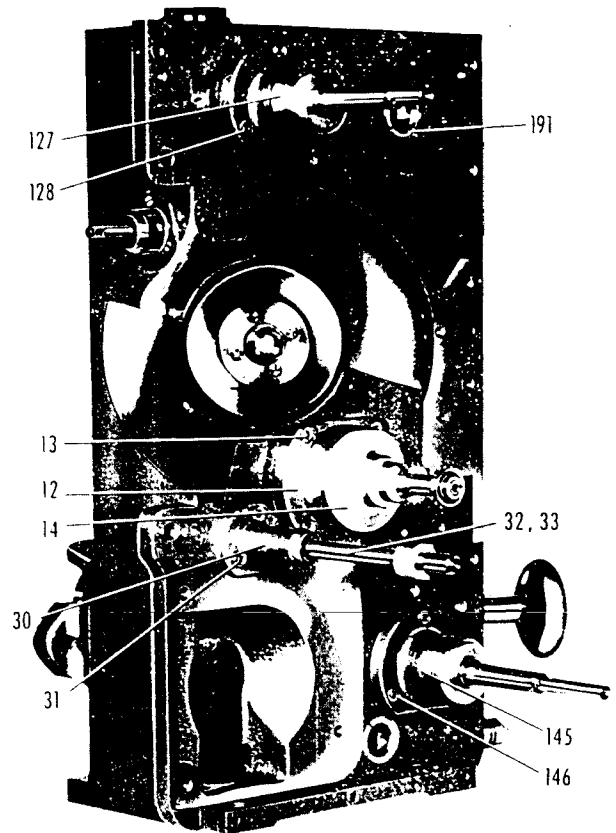
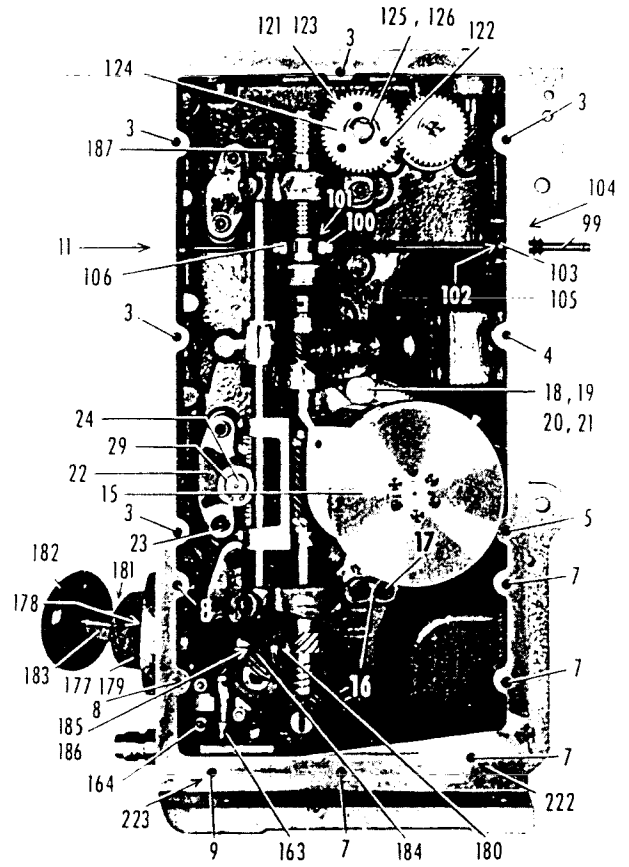
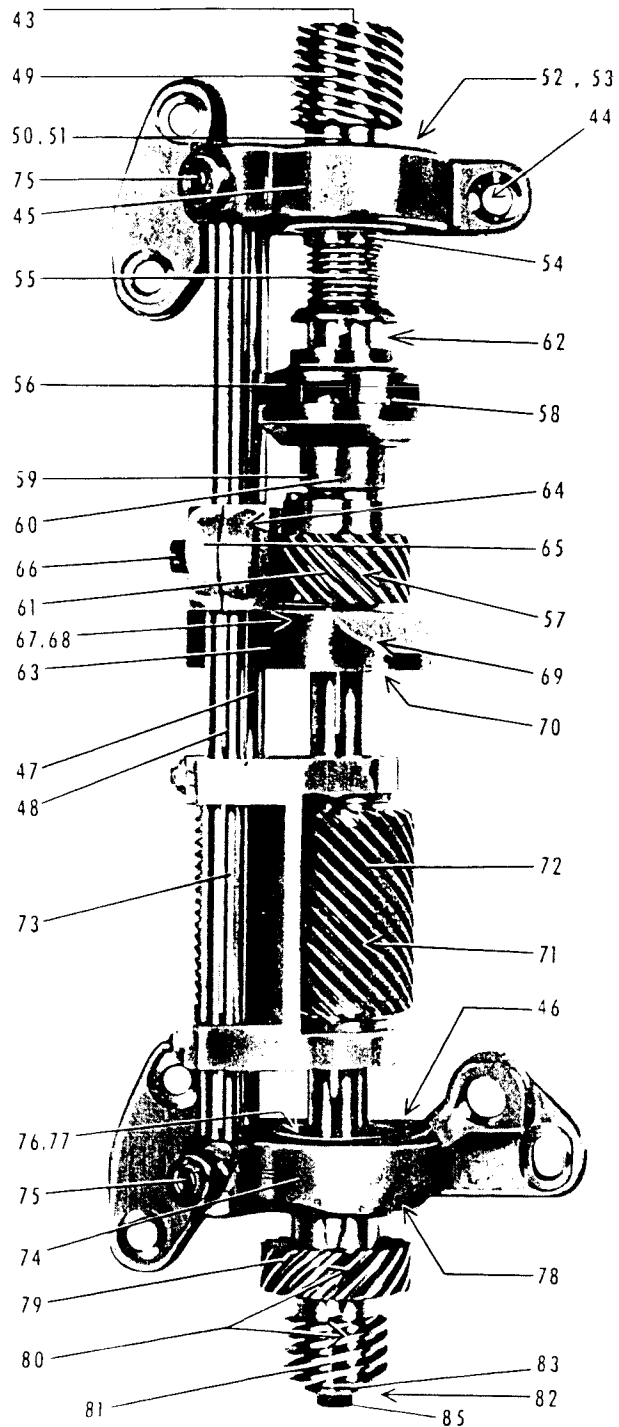
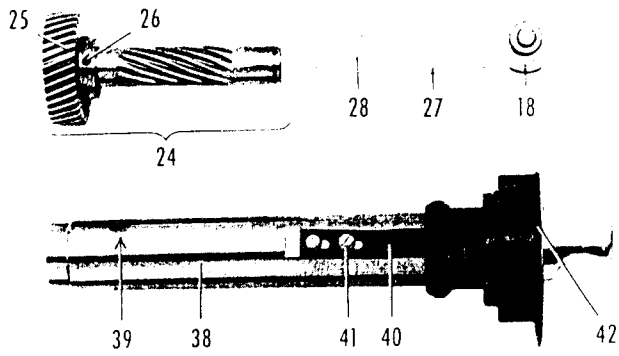

Lfd. Nr.	Stückzahl	ERSATZTEIL-LISTE	SPARE PART LIST	Bestell-Nr.
No.	qt.	Werk-Innenteile	Interiour parts for mechanism	Order No.
62	1	Scheibenfeder	Woodruff key	KE 1/1 . . . X
63	1	Stützlager	supporting bearing	UW 2 LG 4/1 X
64	1	Innensechskantschraube	hexagon socket screw	M 8 x 35 DIN 912 ¹¹⁴
65	1	Lagerbügel	bearing bow	UW 2 LG 3/1 X
66	2	Innensechskantschrauben	hexagon socket screws	M 6 x 18 DIN 912 ¹¹⁴
67	1	Abdeckring	cover ring	UW 2 MR 8/1 X
68	1	Seeger-Innensicherung	spring clip	35 x 1,5 DIN 472
69	1	Kugellager	ball bearing	6003 x DIN 625
70	1	Seeger-Außensicherung	spring clip	17 x 1 DIN 471
71	1	Paßfeder	key	5 x 5 x 25 DIN 6885
72	1	Schieberad	ratched gear	UW 2 ZR 15/3 Z
73	1	Radschieber	bow for ratched gear	UWMF 25/1 Z
74	1	Lagerbock	pillow block	UW 2 LG 1/1 X
75	4	Gewindestifte	threaded pins	AM 8 x 10 DIN 913 ¹¹⁴
76	1	Deckscheibe	cover disc	MBMS 3/2 X
77	1	Kugellager	ball bearing	KL 4/1 Z
78	1	Seeger-Innensicherung	spring clip	35 x 1,5 DIN 472
79	1	Schraubenrad	screw gear	UW 2 ZR 17/3 Z
80	2	Scheibenedern	Woodruff keys	KE 1/1 . . . X
81	1	Schnecke	worm	UW 2 ZR 20/1 X
82	1	Spannstift	clamping pin	2 x 8 DIN 1481
83	1	Sicherungsring	locking ring	MAMR 4/1 X
84	1	Sicherungsblech	locking plate	MABE 1/1 X
85	1	Schraube	screw	M 6 x 12 DIN 931 ¹¹⁴
86	1	Blendenlager	Shutter bearing	UW 2 LG 6/1 Z
87	4	Innensechskantschrauben	hexagon socket screws	M 6 x 18 DIN 912 ¹¹⁴
88	1	Blendenwelle	shutter shaft	UW 2 AC 10/1 X
89	2	Einstellmuttern	adjusting nuts	BW 14 MU 6/1 X
90	1	Sicherungsscheibe	lock washer	BW 14 MS 11/1 X
91	1	Scheibenfeder	Woodruff key	KE 1/1 X
92	1	Schraubenrad	gear	UW 2 ZR 25/1 Z
93	1	Scheibe	washer	MS 45/8 X
94	1	Ölfanghülse	oil catcher	UW 2 MH 4/1 X
95	1	Scheibenfeder	Woodruff key	NKE 3/1 X
96	1	Blendenflansch	shutter flange	UW 2 FL 2/1 X
97	1	Sicherungsblech	locking plate	10 DIN 462 ¹¹⁴
98	1	Sechskantmutter	hexagon nut	UW 2 MU 1/1 X
99	1	Reglerachse	Governor shaft	UW 2 AC 29/1 Z
100	1	Reglerhebel	governor lever	UW 2 HE 9/1 Z
101	1	Sechskantschraube in Pos. 100	hexagon screw	SR 364/1 X ¹¹⁴
102	1	Sicherungsscheibe	lock washer	6 DIN 6799
103	1	Reglerlager	governor bearing	UW 2 LG 11/1 X
104	1	Verschlusskappe	cover cap	UW 2 MF 53/1 X
105	3	Linsenschrauben zu Pos. 103	flat-head screws	M 4 x 10 DIN 85 ¹¹⁴
106	2	Gleitsteine	sliding blocks	MBMF 9/1 X
107	1	Lager (Antrieb MT-Gerät) kompl.	Bearing (Drive for magnetic sound head)	UW 2 LG 8/1 Z
108	1	Innensechskantschraube	hexagon socket screw	M 6 x 15 DIN 912 ¹¹⁴
109	1	Lager (Einzelteil)	bearing (single part)	UW 2 LG 8/1 X
110	1	Schraubenrad (mit Welle)	gear (with shaft)	UW 2 ZR 29/1 X
111	1	Spritzscheibe	splash ring	BDMS 1/1 X
112	1	Distanzring	distance ring	UW 2 MR 17/1 X
113	2	Kugellager	ball bearings	KL 17/1 Z
114	1	Sicherungsring	locking ring	26 x 1,2 DIN 472
115	1	Scheibe	washer	UW 2 MS 6/1 X
116	1	Sicherungsring	locking ring	UW 2 MR 18/1 X
117	1	Kupplungshälfte	coupling half	UW 2 KP 2/1 Z
118	1	Spannstift	clamping pin	2,5 x 14 DIN 1481
119	1	Spannstift	clamping pin	1,5 x 14 DIN 1481
120		Ausgleichscheiben nach Bedarf	washers (as required)	MS 19/1 . . . X
121	1	Zwischenradlager (kompl.)	Idling gear bearing	UW 2 LG 10/1 Z
122	3	Innensechskantschrauben	hexagon socket screws	M 6 x 15 DIN 912 ¹¹⁴

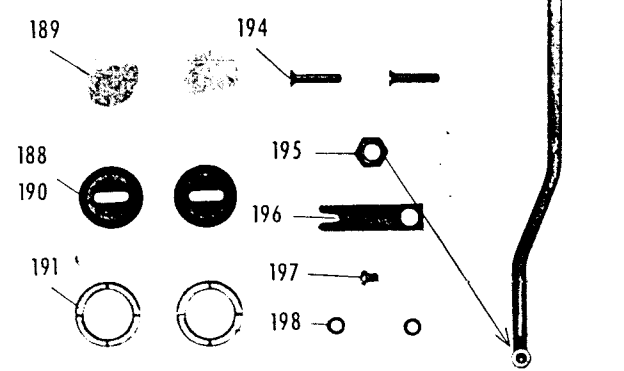
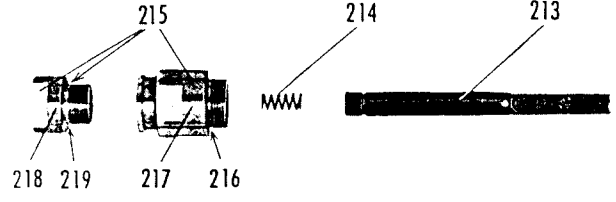
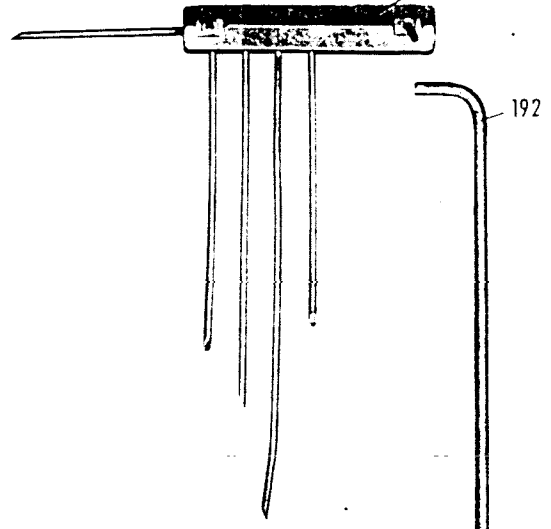
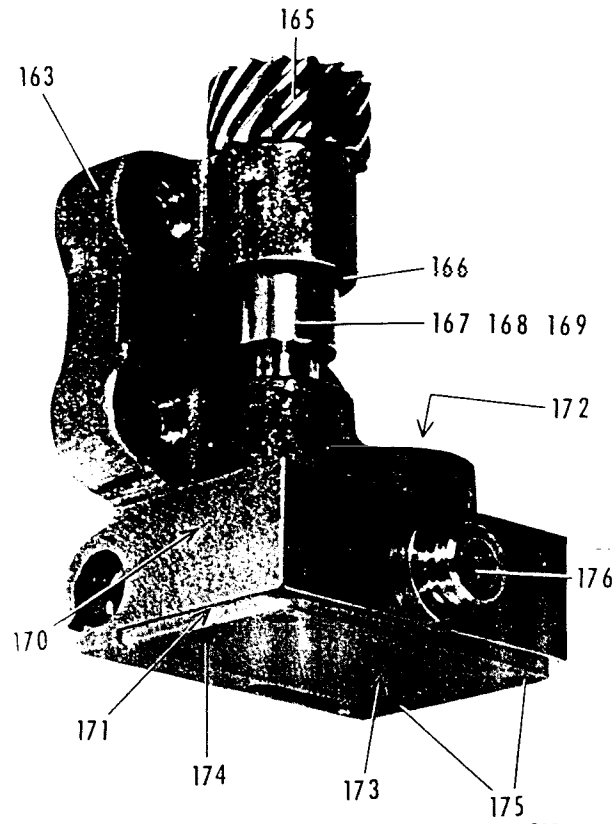
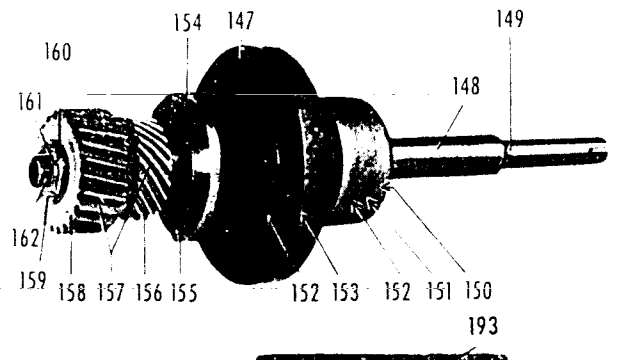
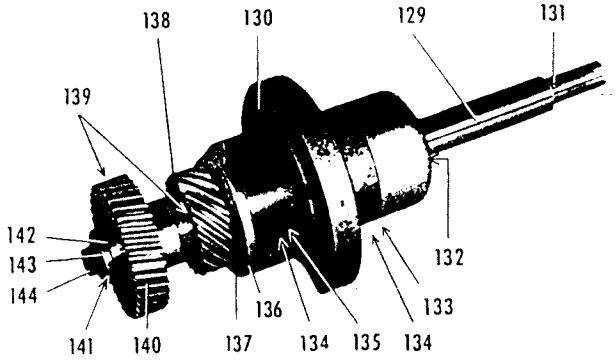
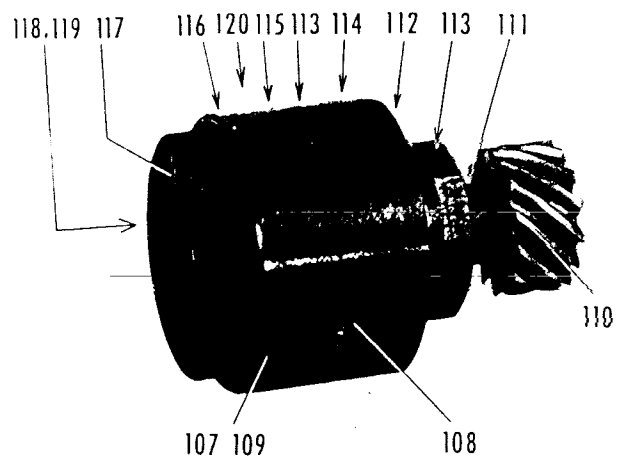
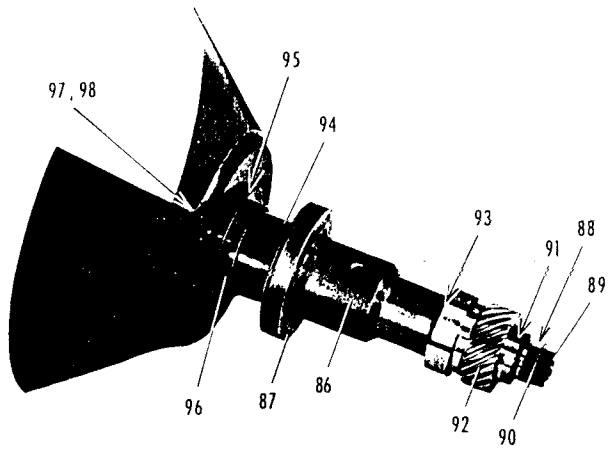

Lfd. Nr.	Stückzahl	ERSATZTEIL-LISTE	SPARE PART LIST	Bestell-Nr.
No.	qt.	Werk-Innenteile	Interior parts for mechanism	Order No.
123	1	Lager (Einzelteil)	bearing (single part)	UW 2 LG 10/1 X
124	1	Schraubenrad	gear	UW 2 ZR 35/1 X
125		Ausgleichscheiben nach Bedarf	washers (as required)	MS 27/1 . . . X
126	1	Bz-Scheibe	clamping washer	9 DIN 6799
127	1	Vorwickellager	Feed sprocket bearing	UW 2 LG 5/2 Z
128	3	Innensechskantschrauben	hexagon socket screws	M 6×15 DIN 912 ²³
129	1	Vorwickelwelle	shaft of feed sprocket	UW 2 AC 8/1 X
130	1	Lager (Einzelteil)	bearing (single part)	UW 2 LG 5/2 Y
131	1	Zylinderstift	cylindrical pin	3×10 DIN 7
132	1	Spritzring	splash ring	UW 2 MR 9/1 X
133	1	Seeger-Innensicherung	spring clip	J 35×1,5 DIN 472
134	2	Kugellager	ball bearings	KL 4/1 Z
135		Ausgleichscheiben nach Bedarf	washers (as required)	MS 29/1 . . . X
136	1	Lagerdeckel	bearing cover	UW 2 DE 3/1 X
137	3	Schrauben	screws	SR 97/3 X ¹⁴
138	1	Schraubenrad	screw gear	UW 2 ZR 21/1 X
139	2	Scheibenfedern	Woodruff keys	KE 1/1 . . . X
140	1	schrägverzahntes Stirnrad	helical-toothed spur gear	UW 2 ZR 22/1 X
141	1	Spannstift	clamping pin	2×8 DIN 1481
142	1	Sicherungsring	locking ring	MAMR 4/1 X
143	1	Sicherungsblech	locking plate	MABE 1/1 X
144	1	Sechskantschraube	hexagon screw	M 6×12 DIN 931 ¹⁴
145	1	Nachwickellager komplett	Take-up sprocket bearing	UW 2 LG 5/1 Z
146	3	Innen-6-Kantschrauben	hexagon socket screws	M 6×15 DIN 912 ²³
147	1	Lager (Einzelteil)	bearing (single part)	UW 2 LG 5/1 Y
148	1	Nachwickelwelle	take-up shaft	UW 2 AC 9/1 X
149	1	Zylinderstift	cylindrical pin	3×10 DIN 7
150	1	Spritzring	splash ring	UW 2 MR 9/1 X
151	1	Seeger-Innensicherung	spring clip	J 35×1,5 DIN 472
152	2	Kugellager	ball bearings	KL 4/1 Z
153		Ausgleichscheiben nach Bedarf	washers (as required)	MS 29/1 . . . X
154	1	Lagerdeckel	bearing cover	UW 2 DE 3/1 X
155	3	Schrauben	screws	SR 97/3 X ¹⁴
156	1	Schraubenrad	screw gear	UW 2 ZR 23/1 X
157	2	Scheibenfedern	Woodruff keys	KE 1/1 . . . X
158	1	Schraubenrad	screw gear	UW 2 ZR 24/1 X
159	1	Spannstift	clamping pin	2×8 DIN 1481
160	1	Sicherungsring	locking ring	MAMR 4/1 X
161	1	Sicherungsblech	locking plate	MABE 1/1 X
162	1	Sechskantschraube	hexagon screw	M 6×12 DIN 931 ¹⁴
163	1	Ölpumpe komplett	Oil pump compl.	UW 2 GE 5/1 Z
164	3	Innen-6-Kantschrauben	hexagon socket screws	M 6×20 DIN 912
165	1	Schraubenradwelle	gear shaft	UW 2 ZR 28/1 Z
166		Ausgleichscheiben nach Bedarf	washers (as required)	MS 20/1 X
167	1	Stellring	adjusting collar	UW 2 MR 11/1 X
168	1	Spannstift	clamping pin	2,5×14 DIN 1481
169	1	Spannstift	clamping pin	1,5×14 DIN 1481
170	1	Scheibenfeder	Woodruff key	NKE 3/1 X
171	1	Zahnrad	gear	MAZR 5/2 X
172	1	Ölpumpenachse (kurz)	oil pump shaft (short)	MAAC 6/1 X
173	1	Zahnrad	gear	MAZR 5/1 X
174	1	Deckel	cover	MADE 4/1 X
175	4	Schrauben	screws	SR 97/2 X
176	1	Gewindenippel	threaded nipple	MARV 1/1 X
177	1	Grifflager komplett	Bearing for control knob	UW 2 LG 7/2 Z
178	3	Innen-6-Kantschrauben	hexagon socket screws	M 6×12 DIN 912 ²³
179	1	Grifflager (Einzelteil)	bearing, single part	UW 2 LG 7/1 X
180	1	Griffachse	shaft for knob	UW 2 AC 11/1 X
181	1	Ölfangkapsel	oil catcher	UW 2 MH 5/1 X
182	1	Handgriff	knob	MBHG 1/7 Z
183	1	Schraube	screw	BW 14 SR 1/1 X ²³

Lfd. Nr.	Stückzahl	ERSATZTEIL-LISTE	SPARE PART LIST	Bestell-Nr.
No.	qt.	Werk-Innenteile	Interior parts for mechanism	Order Nr.
184	1	Schraubenrad	screw gear	UW 2 ZR 27/3 Z
185	1	Innensechskantschraube	hexagon socket screw	M 5×12 DIN 912 ¹⁴
186	1	Zahnscheibe	toothed disc	A 5,3 DIN 6797
187	1	Ölrohrstutzen	oil pipe	BW 14 RR 6/1 X
188	2	Ölstandscheiben	oil level check shield	NS 95/2 X
189	2	Sichtscheiben	oil level glass	BW 14 MS 6/1 X
190	2	Dichtscheiben	packing washers	BW 14 NS 4/2 X
191	2	Gewinderinge	threaded rings	MR 109/1 X
192	1	Ölsteigrohr	oil tube	UW 2 RR 4/1 Z
193	1	Ölverteiler (kpl.)	oil distributor	UW 2 AM 1/1 Z
194	2	Senkschrauben für Pos. 193	counter sunk head screws	M 5×25 DIN 63 ¹⁴
195	1	Überwurfmutter	screw cap	MU 13/1 X
196	1	Lasche	shackle	MAW 105/2 X
197	1	Linsenschraube	flat-head screw	M 4×6 DIN 85
198	2	Dichtungsscheiben	packing washers	MS 344/1 X
199	1	Ölfangkapsel im unt. Werkdeckel außen	oil catcher	UW 2 MF 46/1 X
200	4	Senkschrauben zu Pos. 199	counter sunk screws	3×12 DIN 63 ¹⁴
201	1	Antriebswelle	Drive shaft	UW 2 AC 25/1 X
202	2	Kugellager für Antriebswelle	ball bearings	KL 4/1 Z
203	1	Distanzhülse	distance bush	UW 2 MH 7/1 X
204		Ausgleichscheiben nach Bedarf	washers (as required)	MS 29/1 . . . X
205	1	Lagerdeckel (innen)	bearing cover	UW 2 DE 4/1 X
206	4	Schrauben zu Pos. 205	screws	SR 97/3 X
207	1	Schraubenrad (Antrieb Vertikalwelle)	gear (drive of vertical shaft)	UW 2 ZR 36/3 Z
208	1	Scheibefeder zu Pos. 207	Woodruff key	KE 1/1 . . . X
209	1	Spannstift	clamping pin	2×8 DIN 1481
210	1	Sicherungsring	locking ring	MAMR 4/1 X
211	1	Sicherungsblech	locking plate	MABE 1/1 X
212	1	Sechskantschraube	hexagon screw	M 6×12 DIN 931 ¹⁴
213	1	Ölsieb	oil filter	MAW 118/4 Z
214	1	Feder	spring	FD 12/1 X
215	1	Ölablaßstutzen (kpl.)	oil drain plug (compl.)	MBRV 2/1 Z
216	1	Dichtungsring	packing ring	MBMR 4/1 X
217	1	Ölablaßstutzen (Einzelteil)	oil drain plug (single part)	MBRV 2/1 X ⁹³
218	1	Verschlusschraube	screw plug	MAW 333/1 X ⁹³
219	1	Dichtungsring	packing ring	NS 38/3 X
220	1	Oleinfüllschraube (Seite 11)	oil filling plug	MBSR 7/1 Z
221	1	Dichtungsscheibe zu Pos. 220	packing washer	NS 38/1 X
222	1	Zylinderstift	cylindrical pin	4×36 DIN 7
223	1	Zylinderstift } für unt. Werkdeckel	cylindrical pin	4×28 DIN 7

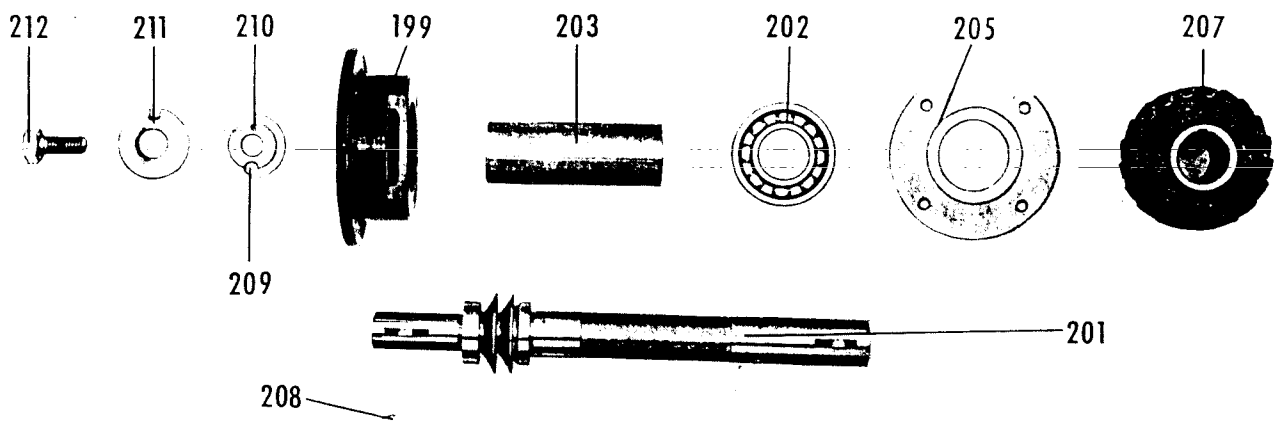

Lfd. Nr.	Stückzahl	ERSATZTEIL-LISTE	SPARE PART LIST	Standard-Ausführung	U.S.A.-Type
No.	qt.	Werk-Außenteile	Outer parts for mechanism		
1	1	Grundplatte (f. Bildfensterhalter) kpl.	Base plate compl. (for aperture)	UW 2 PT 5/1 Z	UW 2 PT 5/1 Z
2	3	Zylinderschrauben (Befestigung Grundplatte)	cylindrical screws (for fastening base plate)	M 8 × 25 DIN 912 ⁸³³	M 8 × 25 DIN 912 ⁸³³
3	1	Grundplatte mit Verschlussstopfen	base plate with filler cap	UW 2 PT 5/1 Y	UW 2 PT 5/1 Y
4	1	Zylinderstift	cylindrical pin	6 × 28 DIN 7	6 × 28 DIN 7
5	2	Verschlussdeckel	sealing plates	12 DIN 443	12 DIN 443
6	2	Buchsen	bushings	UW 2 MB 20/1 X	UW 2 MB 20/1 X
7	2	Druckstücke	pressure pieces	UW 2 MF 65/1 X	UW 2 MF 65/1 X
8	2	Spannstifte	clamping pins	1,5 × 15 DIN 1481	1,5 × 15 DIN 1481
9	2	Druckfedern	pressure springs	UW 2 FS 14/1 X	UW 2 FS 14/1 X
10	2	Gewindestifte	threaded pins	M 4 × 8 DIN 553 ³¹⁴	M 4 × 8 DIN 553 ³¹⁴
11	2	Gewindebolzen	threaded bolts	UW 2 BO 21/1 X	UW 2 BO 21/1 X
12	2	Gewindestifte für Pos. 11	threaded pins	M 6 × 12 DIN 438	M 6 × 12 DIN 438
13		Ausgleichscheiben nach Bedarf f. ob. und unt. Andruckhebel	washers (as required) for upper and lower pressure lever)	MS 27/1 ... X	MS 27/1 ... X
14	1	Objektivschlitten kompl.	Lens carrier	UW 2 MF 47/1 Z	UW 2 MF 47/1 Z
15	3	Innen-6-Kant- } für Objektiv-	hexagon socket screws	M 8 × 20 DIN 912 ⁸³³	M 8 × 20 DIN 912 ⁸³³
16	1	schrauben } schlitten	hexagon socket screw	M 8 × 15 DIN 912 ⁸³³	M 8 × 15 DIN 912 ⁸³³
17	2	Paßkerbstifte zu Pos. 14	grooved dowel pins	4 × 22 DIN 1472	4 × 22 DIN 1472
18	1	Führungsbuchse	guide bushing	UW 2 MB 16/1 X	UW 2 MB 16/1 X
19	1	Führungsschse	guide shaft	UW 2 AC 26/1 X	UW 2 AC 26/1 X
20	1	Gewindestift zu Pos. 19	threaded pin	AM8 × 10 DIN 913 ³¹⁴	AM8 × 10 DIN 913 ³¹⁴
21	2	Seeger-Halbmondringe	crescent shaped snap rings	WN 31 MR 1/19 X	WN 31 MR 1/19 X
22	1	Seeger-Halbmondring	crescent shaped snap ring	WN 31 MR 1/18 X	WN 31 MR 1/18 X
23	1	Führungsbuchse	guiding bush	UW 2 MB 17/1 X	UW 2 MB 17/1 X
24	1	Objektivschlitten	lens carriage	UW 2 MF 47/1 X	UW 2 MF 47/1 X
25	1	Objektivhalter	lens holder	UW 2 BE 3/1 X	UW 2 BE 3/1 X
26	1	Führungsbuchse	guiding bush	UW 2 MB 18/1 X	UW 2 MB 18/1 X
27	8	Linsenschrauben	flat-head screws	M 4 × 12 DIN 85 ⁸³³	M 4 × 12 DIN 85 ⁸³³
28	2	Kugelkäfige	ball cages	UW 2 KL 1/1 Z	UW 2 KL 1/1 Z
29	1	Führungsplatte	guiding plate	UW 2 PT 4/1 X	UW 2 PT 4/1 X
30	1	Führungsschse	guiding shaft	UW 2 AC 27/1 X	UW 2 AC 27/1 X
31	2	Gewindestifte in Pos. 30	threaded pins	M 6 × 12 DIN 438 ³¹⁴	M 6 × 12 DIN 438 ³¹⁴
32	1	Distanzring	distance ring	UW 2 MR 20/1 X	UW 2 MR 20/1 X
33	1	Haltestift	retaining pin	UW 2 ST 2/1 X	UW 2 ST 2/1 X
34	1	Federteller	spring collar	UW 2 MF 48/1 X	UW 2 MF 48/1 X
35	1	Druckfeder	pressure spring	UW 2 FS 10/1 X	UW 2 FS 10/1 X
36	1	Führungsstift	guide pin	UW 2 ST 3/1 X	UW 2 ST 3/1 X
37	1	Sicherungsscheibe	lock washer	4 DIN 6799	4 DIN 6799
38	1	Gewindebuchse	threaded bush	UW 2 MB 19/1 X	UW 2 MB 19/1 X
39	1	Gewindebolzen	threaded bolt	UW 2 BO 17/1 X	UW 2 BO 17/1 X
40	1	Ring	ring	UW 2 MR 21/1 X	UW 2 MR 21/1 X
41	4	Senkschrauben	flat-head screws	SR 97/3 X	SR 97/3 X
42	1	Zwischenlage	shim	UW 2 NS 3/1 X	UW 2 NS 3/1 X
43	1	Einstellmutter	adjusting nut	UW 2 MU 3/1 X	UW 2 MU 3/1 X
44	1	Scheibenfeder	Woodruff key	KE 1/1 X	KE 1/1 X
45	1	Nutmutter	round nut with slot	UW 2 MU 4/1 X	UW 2 MU 4/1 X
46	1	Klinke	latch	UW 2 MF 49/1 X	UW 2 MF 49/1 X
47	1	Rastklotz	stop block	UW 2 MF 50/1 X	UW 2 MF 50/1 X
48	1	Hebel	lever	UW 2 HE 8/1 X	UW 2 HE 8/1 X
49	1	Welle	shaft	UW 2 AC 28/1 X	UW 2 AC 28/1 X
50	1	Zapfenschraube	pivot screw	UW 2 SR 6/1 X	UW 2 SR 6/1 X
51	2	Innen-6-Kantschrauben zu Pos. 47	hexagon socket screws	M 5 × 12 DIN 912 ³¹⁴	M 5 × 12 DIN 912 ³¹⁴
52	1	Drehfeder	torsion spring	UW 2 FS 11/1 X	UW 2 FS 11/1 X
53	1	Sicherungsscheibe	lock washer	9 DIN 6799	9 DIN 6799
54	1	Linsenschraube	flat-head screw	4 × 12 DIN 85 ⁸³³	4 × 12 DIN 85 ⁸³³
55	1	Filmbahnhalter	filmtrack support	UW 2 MF 51/1 X	UW 2 MF 51/1 X
56	2	Bolzen	pins	UW 2 BO 18/1 X	UW 2 BO 18/1 X
57	2	Spannstifte	clamping pins	2,5 × 20 DIN 1481	2,5 × 20 DIN 1481
58	1	Innen-6-Kantschrauben	hexagon socket screws	M 8 × 25 DIN 912 ⁸³³	M 8 × 25 DIN 912 ⁸³³

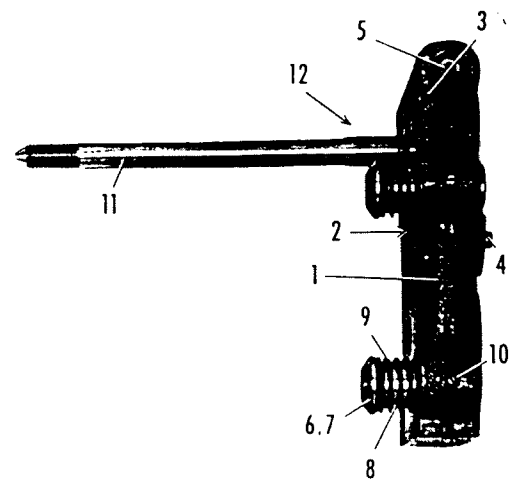
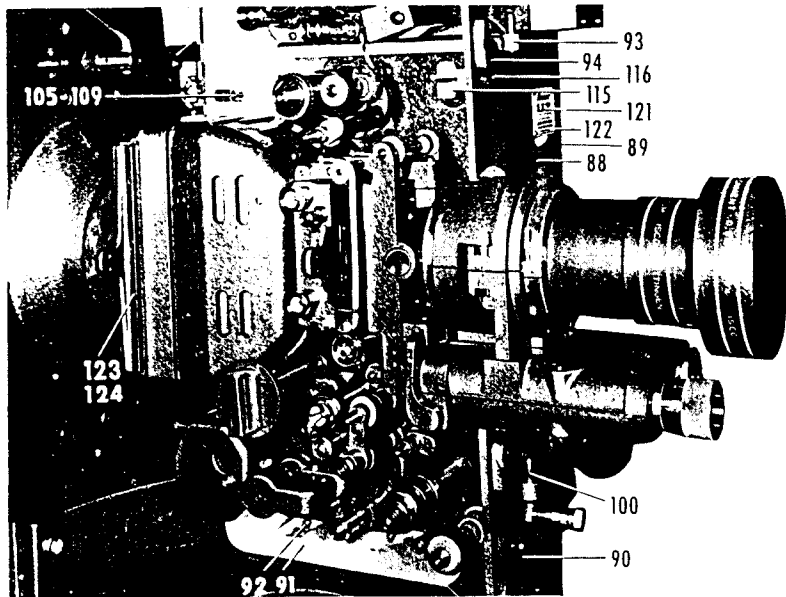
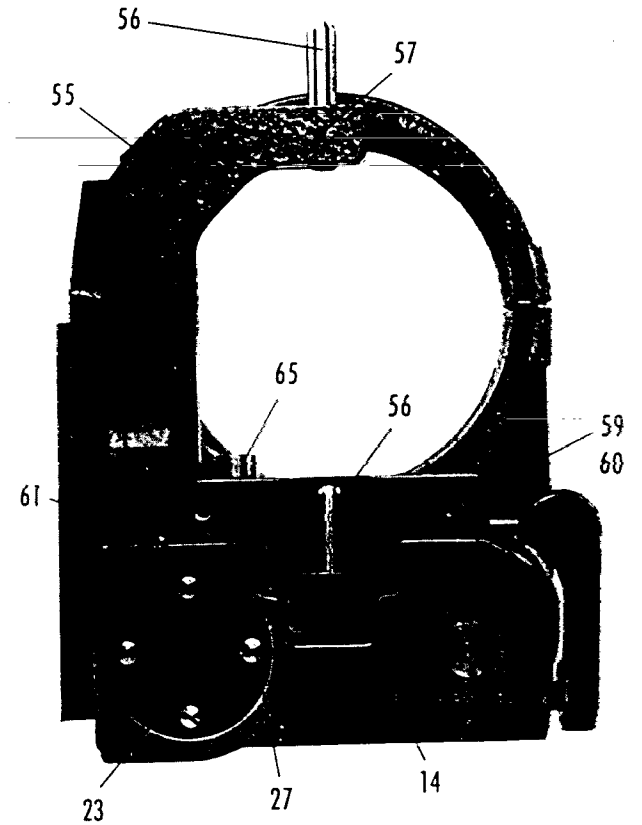
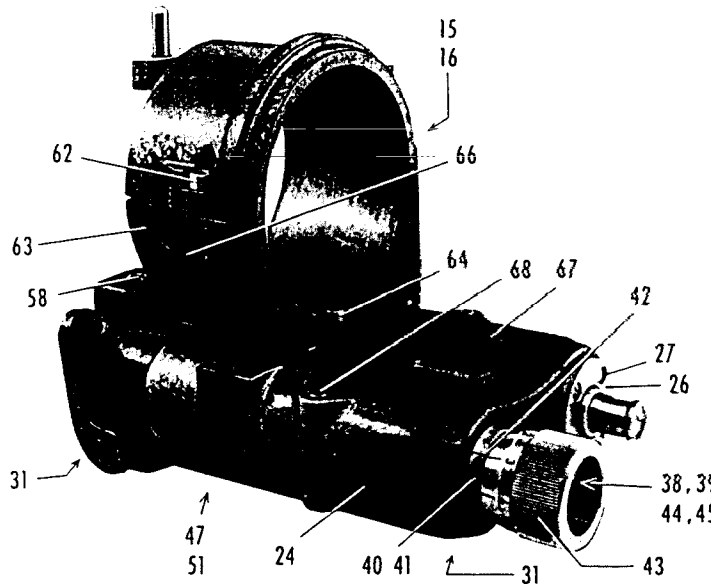
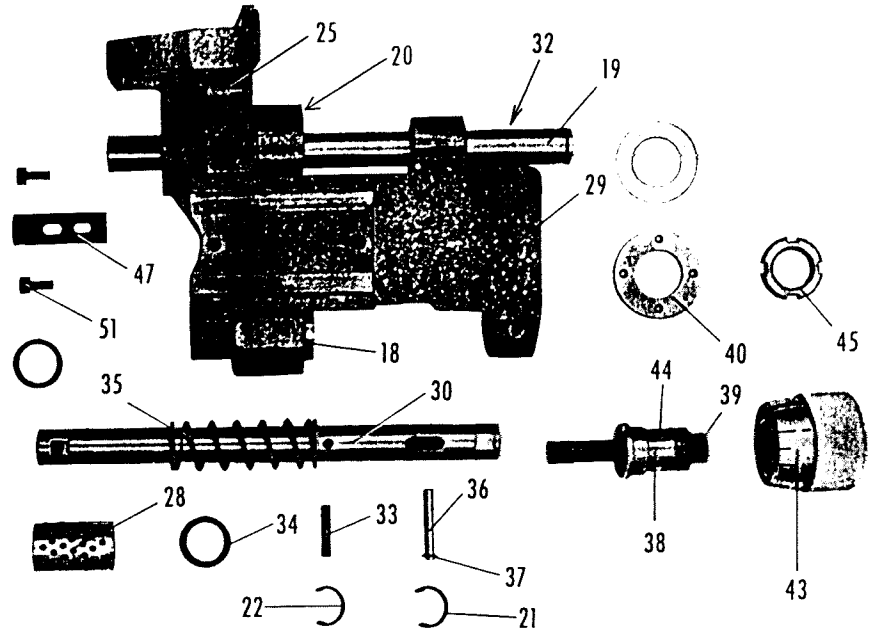
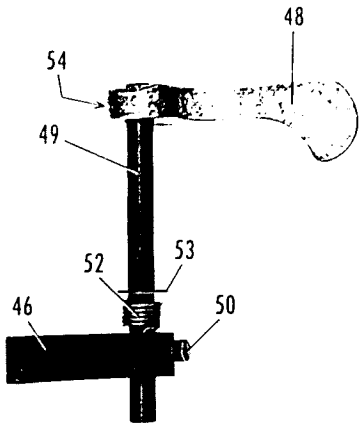

Lfd. Nr.	Stückzahl	ERSATZTEIL-LISTE	SPARE PART LIST	Standard-Ausführung	U. S. A.-Type
No.	qt.	Werk-Außerteile	Outer parts for mechanism		
59	2	Stiftschrauben	stud bolts	UW 2 SR 8/1 X	UW 2 SR 8/1 X
60	2	Sechskantmuttern	hexagons nuts	BM 6 DIN 439	BM 6 DIN 439
61	1	Zylinderstift	cylindrical pin	4 x 25 DIN 7	4 x 25 DIN 7
62	1	Innen-6-Kantschrauben	hexagon socket screw	M 8 x 35 DIN 912 ⁸³³	M 8 x 35 DIN 912 ⁸³³
63	1	Klemmfassung	clamping mounts	UW 2 FA 12/1 X	UW 2 FA 12/1 X
64	2	Innen-6-Kantschrauben	hexagon socket screws	M 6 x 25 DIN 912 ⁸³³	M 6 x 25 DIN 912 ⁸³³
65	1	Innen-6-Kantschraube	hexagon socket screw	M 8 x 35 DIN 912 ⁸³³	M 8 x 35 DIN 912 ⁸³³
66	1	Vierkantmutter	square nut	UW 2 MU 5/1 X	UW 2 MU 5/1 X
67	1	Deckel	cover	UW 2 DE 7/1 X	UW 2 DE 7/1 X
68	2	Innen-6-Kantschrauben	hexagon socket screws	M 5 x 50 DIN 912 ⁸³³	M 5 x 50 DIN 912 ⁸³³
69	1	Luftrohr	Air pipe		
70	1	Winkel	elbow	UW 2 RR 5/1 X	UW 2 RR 5/1 X
71	2	Rohrschellen	pipe clips	UW 2 MF 71/1 X	UW 2 MF 71/1 X
72	2	Zylinderschrauben	pipe clips	RS 22/1 X ³¹⁴	RS 22/1 X ³¹⁴
73	2	Sechskantmuttern zu Pos. 72	cylindrical screws	M 4 x 5 DIN 84 ³¹⁴	M 4 x 5 DIN 84 ³¹⁴
74	1	In.-6-Kantschr. Bef. Magnet-	hexagon nuts for	M 4 DIN 934 ³¹⁴	M 4 DIN 934 ³¹⁴
75	2	In.-6-Kantschr. gehäuse	hexagon socket screw fastening hexagon socket screws base plate for magnet	M 8 x 25 DIN 912 ³¹⁴ M 8 x 60 DIN 912 ³¹⁴	M 8 x 25 DIN 912 ³¹⁴ M 8 x 60 DIN 912 ³¹⁴
76	1	Schiene (auf Reglerachse)	rail (on shaft)	UW 2 MF 19/1 Z	UW 2 MF 19/1 Z
77	1	Kreuzlochschraube	cross hole screw	UW 2 SR 9/1 X	UW 2 SR 9/1 X
78	1	Kegeblend (fest)	cone shutter (fixed)	UW 2 MF 72/1 X	UW 2 MF 72/1 X
79	1	Kegeblend (verstellbar)	cone shutter (adjustable)	UW 2 MF 72/2 Z	UW 2 MF 72/2 Z
80	1	Anpreßscheibe	pressure washer	UW 2 MS 8/1 X	UW 2 MS 8/1 X
81	4	Linsenschrauben	flat-head screws	M 4 x 10 DIN 85 ³¹⁴	M 4 x 10 DIN 85 ³¹⁴
82	1	Winkeldeckel	cover for rear part of shutter housing	UW 2 DE 8/1 X	UW 2 DE 8/1 X
83	2	Fangstifte in Pos. 82	catch bolts	UW 2 ST 5/1 X	UW 2 ST 5/1 X
84	2	Gewindestifte	threaded pins	M 4 x 6 DIN 438 ³¹⁴	M 4 x 6 DIN 438 ³¹⁴
85	2	Rändelmuttern	knurled nuts	BW 14 MU 3/1 X	BW 14 MU 3/1 X
86	1	Leitdeckel	cover for air conduct	UW 2 DE 9/1 X	UW 2 DE 9/1 X
87	1	Innen-6-Kantschraube	hexagon socket screw	M 6 x 20 DIN 912 ⁸³³	M 6 x 20 DIN 912 ⁸³³
88	1	Rahmenoberteil	upper frame part	UW 2 MF 56/1 X	UW 2 MF 56/1 X
89	5	Innen-6-Kantschrauben f. Pos. 88	hexagon socket screws	M 8 x 18 DIN 912 ⁸³³	M 8 x 18 DIN 912 ⁸³³
90	1	Rahmenseite	side of frame	UW 2 MF 57/1 X	UW 2 MF 57/1 X
91	1	Rahmenunterteil (LT-Gerät)	lower frame part (optic soundhead)	UW 2 MF 58/1 X	UW 2 MF 58/1 X
92	3	Innen-6-Kantschrauben	hexagon socket screws	M 6 x 25 DIN 912 ⁸³³	M 6 x 25 DIN 912 ⁸³³
93	2	Scharnierarme	hinges	UW 2 MF 59/1 X	UW 2 MF 59/1 X
94	6	Innen-6-Kantschrauben	hexagon socket screws	M 6 x 15 DIN 912 ⁸³³	M 6 x 15 DIN 912 ⁸³³
95	1	Türe	door	UW 2 MF 55/1 X	UW 2 MF 55/1 X
96	2	Scharnierwinkel	hinges	UW 2 MF 61/1 X	UW 2 MF 61/1 X
97	4	Innen-6-Kantschrauben	hexagon socket screws	M 6 x 18 DIN 912 ⁸³³	M 6 x 18 DIN 912 ⁸³³
98	4	Zahnscheiben	toothed discs	I 6,4 DIN 6797	I 6,4 DIN 6797
99	4	Sechskantmuttern	hexagons nuts	M 6 DIN 439 ⁸³⁴	M 6 DIN 439 ⁸³⁴
100	2	Scharnierstifte	hinge pins	UW 2 ST 4/1 X	UW 2 ST 4/1 X
101	1	Türgriff	door handle	UW 2 HG 4/1 X	UW 2 HG 4/1 X
102	2	Linsenschrauben	flat head screws	M 4 x 28 DIN 85 ⁸³³	M 4 x 28 DIN 85 ⁸³³
103	2	Rastbolzen	stop bolts	UW 2 BO 20/1 X	UW 2 BO 20/1 X
104	2	Gewindestifte	threaded pins	M 4 x 12 DIN 438 ⁸³³	M 4 x 12 DIN 438 ⁸³³
105	2	Rastfedern	stop springs	UW 2 FB 5/1 X	UW 2 FB 5/1 X
106	2	Begrenzungswinkel	limit angle	UW 2 MF 64/1 X	UW 2 MF 64/1 X
107	4	Senkschrauben	flat head screws	M 3 x 12 DIN 87 ⁸³³	M 3 x 12 DIN 87 ⁸³³
108	4	Sechskantmuttern	hexagon nuts	M 3 DIN 934 ⁸³⁴	M 3 DIN 934 ⁸³⁴
109	4	Scheiben	washers	3,2 DIN 125 ⁸³⁴	3,2 DIN 125 ⁸³⁴
110	1	Plexiglasscheibe oben	Plexiglass plate (top)	UW 2 FE 3/1 X	UW 2 FE 3/2 X
111	1	Plexiglasscheibe unten	Plexiglass plate (bottom)	UW 2 FE 4/1 X	UW 2 FE 4/1 X
112	9	Linsensenkschrauben	counter sunk head screws	M 3 x 8 DIN 88 ⁸³³	M 3 x 8 DIN 88 ⁸³³
113	1	Schild	plate	UW 2 SQ 2/1 X	UW 2 SQ 2/1 X
114	4	Linsenschrauben	flat head screws	M 4 x 8 DIN 85 ⁸³³	M 4 x 8 DIN 85 ⁸³³
115	1	Lagerbock	pillow block	UW 2 MF 62/1 Z	UW 2 MF 62/1 Z
116	2	Innen-6-Kantschrauben	hexagon socket screws	M 5 x 12 DIN 912 ⁸³³	M 5 x 12 DIN 912 ⁸³³
117	1	Schiene	rail	UW 2 MF 63/1 Z	UW 2 MF 63/1 Z

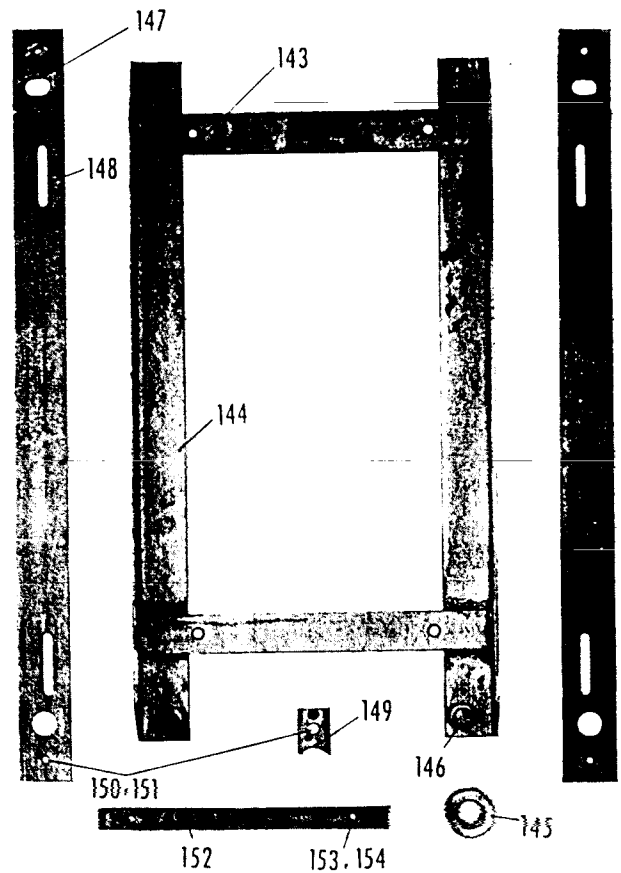
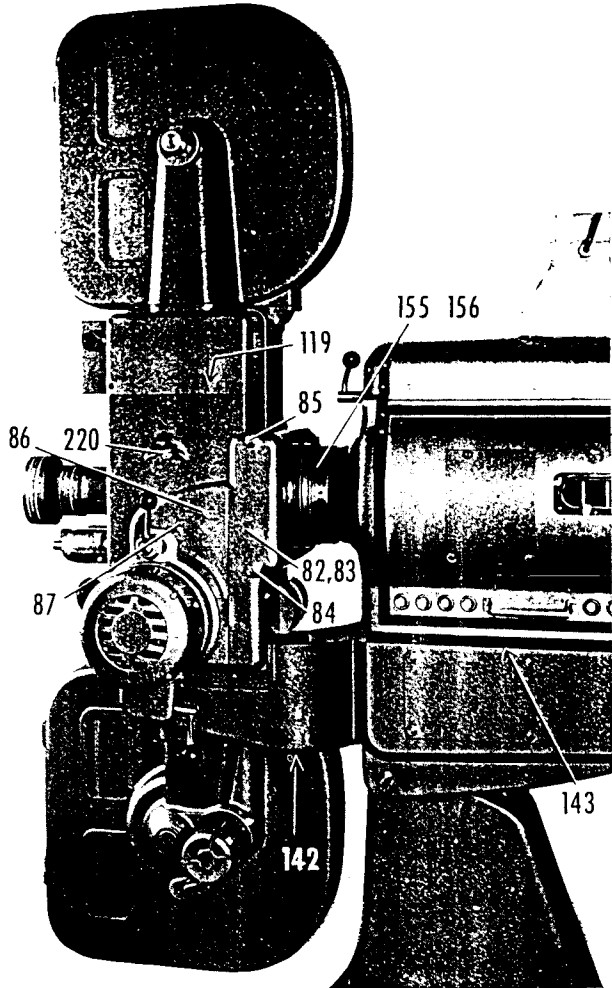
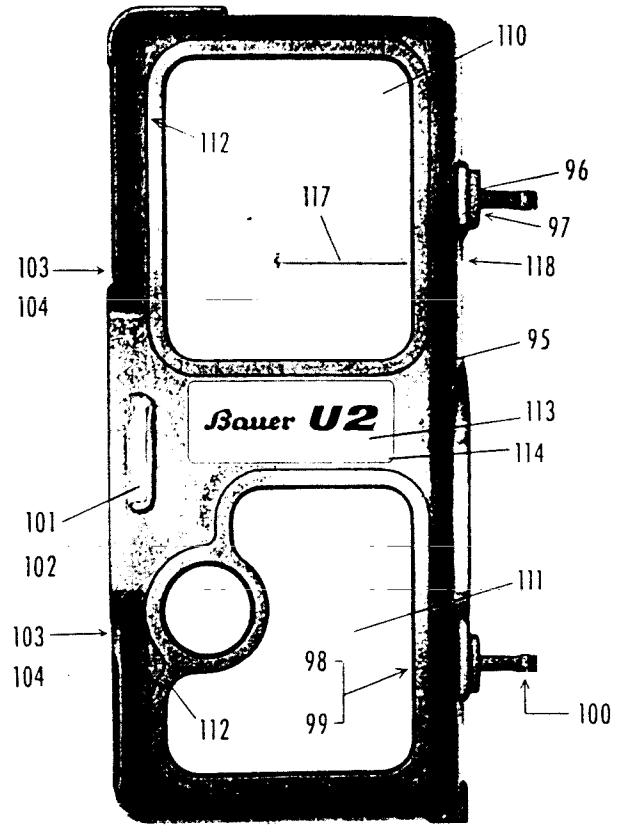
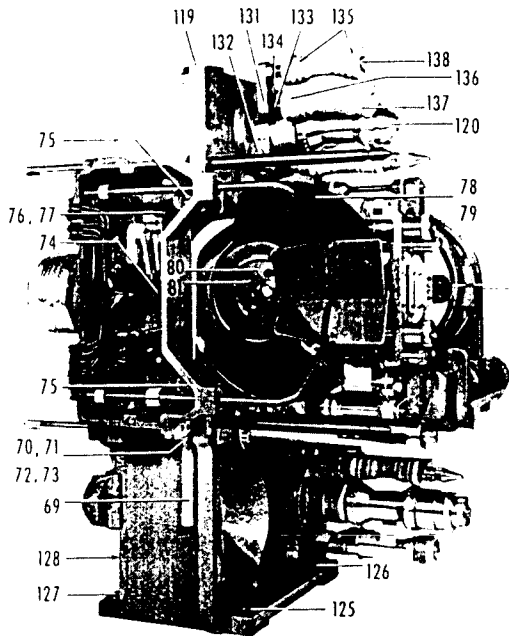

Lfd. Nr.	Stückzahl	ERSATZTEIL-LISTE	SPARE PART LIST	Standard-Ausführung	U. S. A.-Type
No.	qt.	Werk-Außenteile	Outer parts for mechanism		
118	1	Gewindestift für Pos. 117	threaded pin	M 5 × 10 DIN 438 ⁸³³	M 5 × 10 DIN 438 ⁸³³
119	1	Kupplungsring (MT-Gerät)	coupling ring (magn. sound head)	UW 2 NR 1/1 X	UW 2 NR 1/1 X
120	1	Kegelring	conical ring	UW 2 MR 23/1 Z	UW 2 MR 23/1 Z
121	1	Schild	plate	UW 2 SQ 3/1 X	UW 2 SQ 3/1 X
122	4	Linsenschrauben zu Pos. 121	flat-head screws	M 3 × 4 DIN 85 ⁸³³	M 3 × 4 DIN 85 ⁸³³
123	1	Linsenhalter für Linse 160	lens holder	UW 2 FA 10/1 Z	UW 2 FA 10/1 Z
124	1	Linsenhalter für Linse 180	lens holder	UW 2 FA 9/1 Z	UW 2 FA 9/1 Z
125	1	Innensechskantschraube	hexagon socket screw	M 10 × 20 DIN 912 ³¹⁴	M 10 × 20 DIN 912 ³¹⁴
126	1	Innensechskantschraube	hexagon socket screw	M 10 × 30 DIN 912 ⁸³³	M 10 × 30 DIN 912 ⁸³³
127	1	Innensechskantschraube	hexagon socket screw	M 10 × 30 DIN 912 ³¹⁴	M 10 × 30 DIN 912 ³¹⁴
128	1	Innensechskantschraube	hexagon socket screw	M 10 × 60 DIN 912 ³¹⁴	M 10 × 60 DIN 912 ³¹⁴
129	1	Hülse zu Pos. 128	bush	UW 2 MH 1/1 X	UW 2 MH 1/1 X
130	1	Rollenhalter kompl. an Vorwickelnabe	roller assembly compl. on hub of feed roller	UW 2 BE 7/1 Z	UW 2 BE 7/1 Z
131	1	Rollenhalter, Einzelteil	roller assembly, single part	UW 2 BE 7/1 X	UW 2 BE 7/1 X
132	1	Innensechskantschraube	hexagon socket screw	M 6 × 22 DIN 912 ⁸³³	M 6 × 22 DIN 912 ⁸³³
133	1	Stehbolzen	staybolt	UW 2 BO 33/1 X	UW 2 BO 33/1 X
134	1	Stehbolzen	staybolt	UW 2 BO 34/1 X	UW 2 BO 34/1 X
135	2	Gleitrollenhälften	idler roller halves	UW 2 RL 2/1 X	UW 2 RL 2/1 X
136	1	Führungsrollenhälfte	guide roller half	UA 2 RL 4/1 X	UA 2 RL 4/1 X
137	1	Führungsrollenhälfte	guide roller half	UA 2 RL 5/1 X	UA 2 RL 5/1 X
138	1	Schraube	screw	SR 56/1 X ⁸³³	SR 56/1 X ⁸³³
140	3	Innensechskantschrauben	hexagon socket screws	M 8 × 15 DIN 912 ³¹⁴	M 8 × 15 DIN 912 ³¹⁴
141	3	Scheiben	washers	8,4 DIN 125 ³¹⁴	8,4 DIN 125 ³¹⁴
142	3	Innensechskantschrauben für Vorverstärkerwinkel (USA)	hexagon socket screws for pre-amplifier angle	—	M 6 × 18 DIN 912 ⁸³³
143	1	Lampen-Unterbau-Teilegruppe (USA)	Arc support parts group	—	UF 2 TG 1/1 Z
144	1	Rahmen	frame	—	UF 2 MF 1/1 Z
145	4	Rundmuttern	round nuts	—	UF 2 MU 1/1 X
146	4	Seegerringe	snaprings	—	14 × 1 DIN 471
147	2	Schienen	rails	—	UF 2 MF 4/1 X
148	4	Schaftschrauben	screws	—	M 8 × 18 DIN 427 ⁸⁴³
149	4	Laschen	shackle	—	UF 2 MF 6/1 Z
150	4	Sechskantschrauben	hexagon screws	—	M 8 × 16 DIN 931 ⁸⁴³
151	4	Unterlegscheiben	washers	—	8,4 DIN 125 ⁸⁴³
152	1	Klemmschiene	flat steel clamp	—	UF 2 MF 5/1 X
153	2	Sechskantschrauben	hexagon screws	—	M 8 × 35 DIN 931 ³¹⁴
154	2	Scheiben	washers	—	MS 139/2 X ³¹⁴
155	1	Trichter für HI 90 o. BL 9 X	cone for HI 90 or BL 9 X	BL 5 MF 12/1 Z	BL 5 MF 12/1 Z
156	1	Trichter für HI 170	cone for HI 170	BL 10 MF 105/1 Z	BL 10 MF 105/1 Z
		Bei Verwendung einer Ventarc-Lampe:	with Ventarc-Lamp:		
157	1	Zwischenplatte zur Vorversetzung der Abwickeltrommel	adapter plate	—	UA 2 PT 3/1 X
158	4	Innensechskantschraube Bei Abwärtsprojektion von 12° bis 20°:	hexagon socket screw with downward projection of 12° to 20°:	—	M 6 × 20 DIN 912 ³¹⁴
159	1	Keilunterlage	wedge shaped base for lower magazine	UA 2 MF 18/1 X	UA 2 MF 18/1 X
160	3	Innensechskantschrauben	hexagon socket screws	M 8 × 22 DIN 912 ³¹⁴	M 8 × 22 DIN 912 ³¹⁴

Lfd. Nr.	Stückzahl	ERSATZTEIL-LISTE	SPARE PART LIST	Standard-Ausführung	U.S.A.-Type
No.	qt.	Werk-Außenteile	Outer parts for mechanism		
	1	Friktionsausgleich komplett	Friction adjustment compl.	UA 2 TG 3/1 Z	UA 2 TG 3/1 Z
161	1	Winkel	elbow	UA 2 MF 25/1 X	UA 2 MF 25/1 X
162	1	Hebel	lever	UA 2 HE 5/1 X	UA 2 HE 5/1 X
163	1	Spannbolzen	clamping bolt	UA 2 BO 6/2 X	UA 2 BO 6/2 X
164	1	Spannbüchse	clamping bush	UA 2 MB 4/2 X	UA 2 MB 4/2 X
165	1	Blattfeder	leaf spring	BL 10 FB 3/1 X	BL 10 FB 3/1 X
166	1	Schraubenfeder	spiral spring	FD 9/1 X	FD 9/1 X
167	1	Linsenschraube	screw	M 4×4 DIN 85	M 4×4 DIN 85
168	1	Innensechskantschraube	hexagon socket screw	UA 2 SR 6/1 X	UA 2 SR 6/1 X
169	1	BZ-Scheibe	clamping washer	6 DIN 6799	6 DIN 6799
	1	Einbau-Plan	mounting plane	EP 236	EP 236

Blattfederdruck mit Hilfe der Schraube (Pos. 168) so einstellen, daß der Film beim Anlauf und bei leerer Spule nach der Nachwickelrolle gerade noch ohne Schleifenbildung in die Trommel gezogen wird.

Adjust tension of leaf spring by means of screw in such a way that the film will not form a back latch when starting the projector with empty reel.

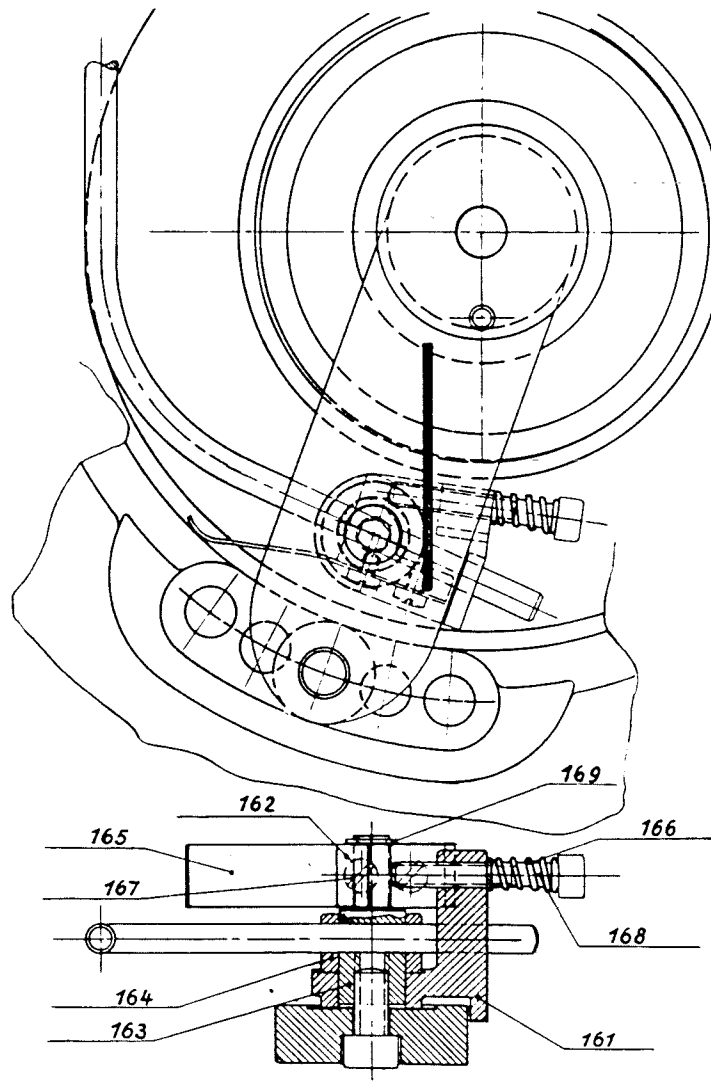

Lfd. Nr.	Stückzahl	ERSATZTEIL-LISTE	SPARE PART LIST	Standard-Ausführung	U. S. A.-Type
No.	qt.	Magnetgehäuse	Base plate for magnet		
1	1	Magnetgehäuse komplett	Base plate for magnet, complete	UW 2 GE 2/1 Z	UW 2 GE 2/2 Z
2	1	Magnetgehäuse	base plate for magnet	UW 2 GE 2/1 X	UW 2 GE 2/1 X
3	1	Welle mit Fallkl.hälfte oben	shaft for shutter half (top)	UW 2 AC 1/1 Y	UW 2 AC 1/1 Y
4	1	Welle mit Fallkl.hälfte unten	shaft for shutter half (below)	UW 2 AC 2/1 Y	UW 2 AC 2/1 Y
5	4	Scheiben	washers	MS 14/4 X	MS 14/4 X
6	2	Scheiben nur bei Bedarf	washers, only if needed	MS 332/1 X	MS 332/1 X
7	4	Sicherungsringe	locking rings	7×0,8 DIN 471	7×0,8 DIN 471
8	2	Schalthebel	switch levers	UW 2 HE 1/1 X	UW 2 HE 1/1 X
9	2	Spannstifte	clamping pins	2,5×14 DIN 1481	2,5×14 DIN 1481
10	2	Bolzen	pins	BW 14 BO 47/1 X	BW 14 BO 47/1 X
11	3	Scheiben unten	washers below	MS 4/7 X	MS 4/7 X
12	3	Scheiben oben	washers above	MS 4/4 X	MS 4/4 X
13	2	Sicherungsscheiben je 1 unten und oben	locking washers one each on top and bottom	3,2 DIN 6799	3,2 DIN 6799
14	2	Schienen	bars	UW 2 MF 12/1 X	UW 2 MF 12/1 X
15	1	Bügel	bow	UW 2 MF 11/1 Z	UW 2 MF 11/1 Z
16	1	Stehbolzen	staybolt	UW 2 BO 2/1 X	UW 2 BO 2/1 X
17	1	Sechskantmutter	hexagon nut	BM 8 DIN 439 ³¹⁴	BM 8 DIN 439 ³¹⁴
18	1	Drehmagnet für 60 V =	turning magnet for 60 V =	BW 14 MA 3/1 Y	BW 14 MA 3/1 Y
19	3	Scheiben } für Magnet	washers } for magnet	5,3 DIN 125 ³¹⁴	5,3 DIN 125 ³¹⁴
20	3	Schrauben } für Magnet	screws } for magnet	M 5x18 DIN 931 ³¹⁴	M 5x18 DIN 931 ³¹⁴
21	1	Zahnrad auf Magnetanker	gear on magnetic armature	UW 2 ZR 2/1 Z	UW 2 ZR 2/1 Z
22	1	Spannstift für Befestigung Zahnrad	clamping pin for fastening gear	3×16 DIN 1481	3×16 DIN 1481
23	1	Achse	shaft	BW 14 AC 20/1 X	BW 14 AC 20/1 X
24	1	Scheibe	washer	4,3 DIN 125 ³¹⁴	4,3 DIN 125 ³¹⁴
25	2	Sicherungsscheiben	locking washers	3,2 DIN 6799	3,2 DIN 6799
26	1	Zugfeder	tension spring	BW 14 FS 14/1 X	BW 14 FS 14/1 X
27	1	Winkel	angle piece	UW 2 MF 13/1 X	UW 2 MF 13/1 X
28	1	Zahnscheibe	toothed washer	A 5,3 DIN 6797	A 5,3 DIN 6797
29	1	Sechskantschraube	hexagon screw	M 5×8 DIN 931 ³¹⁴	M 5×8 DIN 931 ³¹⁴
30	1	Mikroschalter 380 V, 10 A für Tonl. am Geh.	micro switch 380 V, 10 A for exciter lamp on housing	BW 14 SH 5/1 Z	BW 14 SH 5/1 Z
31	1	Mikroschalter 380 V, 10 A für Selbsth.Kont. f. Drehmagn.	micro switch 380 V, 10 A for self-holding contact for magnet	BW 14 SH 5/1 Z	BW 14 SH 5/1 Z
32	2	Distanzbüchsen	distance bushings	—	UW 2 MB 1/1 X
33	1	Isolierplatte	insulating plate	BW 14 PT 13/1 X	—
34	2	Gewindebolzen	threaded pins	BW 14 BO 48/2 X	BW 14 BO 48/2 X
35	3	Scheiben	washers	3,2 DIN 125 ³¹⁴	3,2 DIN 125 ³¹⁴
36	3	Muttern	nuts	M 3 DIN 934 ³¹⁴	M 3 DIN 934 ³¹⁴
37	1	Hebel obere Hälfte	lever, upper half	UW 2 HE 2/1 X	UW 2 HE 2/1 X
38	1	Hebel untere Hälfte	lever, lower half	UW 2 HE 2/2 X	UW 2 HE 2/2 X
39	1	Zahnscheibe	toothed disc	A 5,3 DIN 6797	A 5,3 DIN 6797
40	1	Sechskantschraube	hexagon screw	M 5×15 DIN 931 ³¹⁴	M 5×15 DIN 931 ³¹⁴
41	1	Achse	shaft	BW 14 AC 19/1 X	BW 14 AC 19/1 X
42	2	Scheiben	washers	MS 5/4 X	MS 5/4 X
43	1	Sicherungsscheibe	locking washer	3,2 DIN 6799	3,2 DIN 6799
44	1	Zugschiene	draw bar	UW 2 MF 14/1 Z	UW 2 MF 14/1 Z
45	1	Schnappschalter 380 V, 15 A für Überldg. am Gehäuse	snap switch 380 V 15 Amps. for change-over on housing	MBSH 4/1 Z	MBSH 4/1 Z
46	1	Schnappschalter 380 V, 15 A für Anlaß.Wdst. vorne	snap switch 380 V 15 Amps. for starter resistance, front	MBSH 4/1 Z	MBSH 4/1 Z
47	1	Leiste	panel	BL 10 MF 37/1 X	BL 10 MF 37/1 X
48	2	Schrauben	screws	M 4×50 DIN 84 ³¹⁴	M 4×50 DIN 84 ³¹⁴
49	2	Scheiben	washers	4,3 DIN 125	4,3 DIN 125
50	1	Anreihklemme unten	terminal block, below	PW 3 EA 1/4 Z	PW 3 EA 1/4 Z
51	1	Anreihklemme oben	terminal block, above	PW 3 EA 1/9 Z	PW 3 EA 1/8 Z
52	4	Sechskantschrauben	hexagon screws	M 4×15 DIN 931 ³¹⁴	M 4×15 DIN 931 ³¹⁴
53	18	Nummernschilder	name plates	PW 3 SQ 4/1 X	16 pieces
54	18	Cellophanfenster	cellophane plates	PW 3 FE 5/1 X	16 pieces
55	1	Kondensator	condenser	K - 15 F 500 CE1	K - 15 F 500 CE1

Lfd. Nr.	Stückzahl	ERSATZTEIL-LISTE	SPARE PART LIST	Standard-Ausführung	U.S.A.-Type
No.	qt.	Magnetgehäuse	Base plate for magnet		
56	1	Erdschraube	grounding screw	AM 4×6 DIN 85 ^{31A}	AM 4×6 DIN 85 ^{31A}
57	1	Lüsterklemme für Bildstrichlampe	terminal block for framing lamp	BW 14 EA 3/1 Z	BW 14 EA 3/1 Z
58	1	Zahnscheibe	toothed disc	A 3,2 DIN 6797	A 3,2 DIN 6797
59	1	Zylinderschraube	cylindrical screw	M 3×18 DIN 84 ^{31A}	M 3×18 DIN 84 ^{31A}
60	2	Stehbolzen	stay bolts	BW 14 BO 28/5 X	BW 14 BO 28/5 X
61	2	Gewindestifte	threaded pins	M 6×8 DIN 438 ^{31A}	M 6×8 DIN 438 ^{31A}
62	1	Deckel	cover	UW 2 DE 1/1 X	UW 2 DE 1/1 X
63	2	Schrauben	screws	M 4×10 DIN 85 ^{31A}	M 4×10 DIN 85 ^{31A}
64	1	Kabelsatz	set of cables	UW 2 KA 1/1 Z	UW 2 KA 1/2 Z

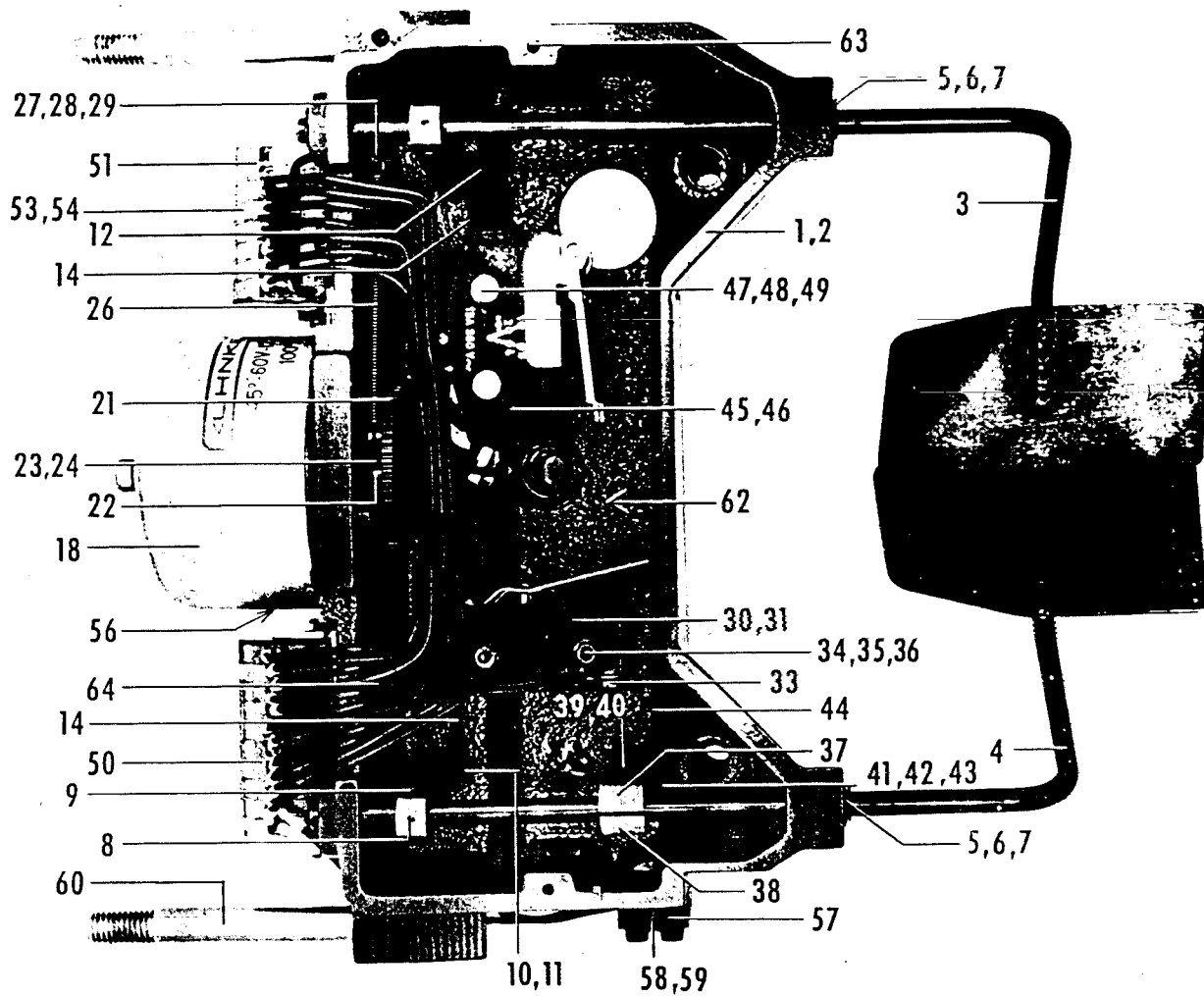

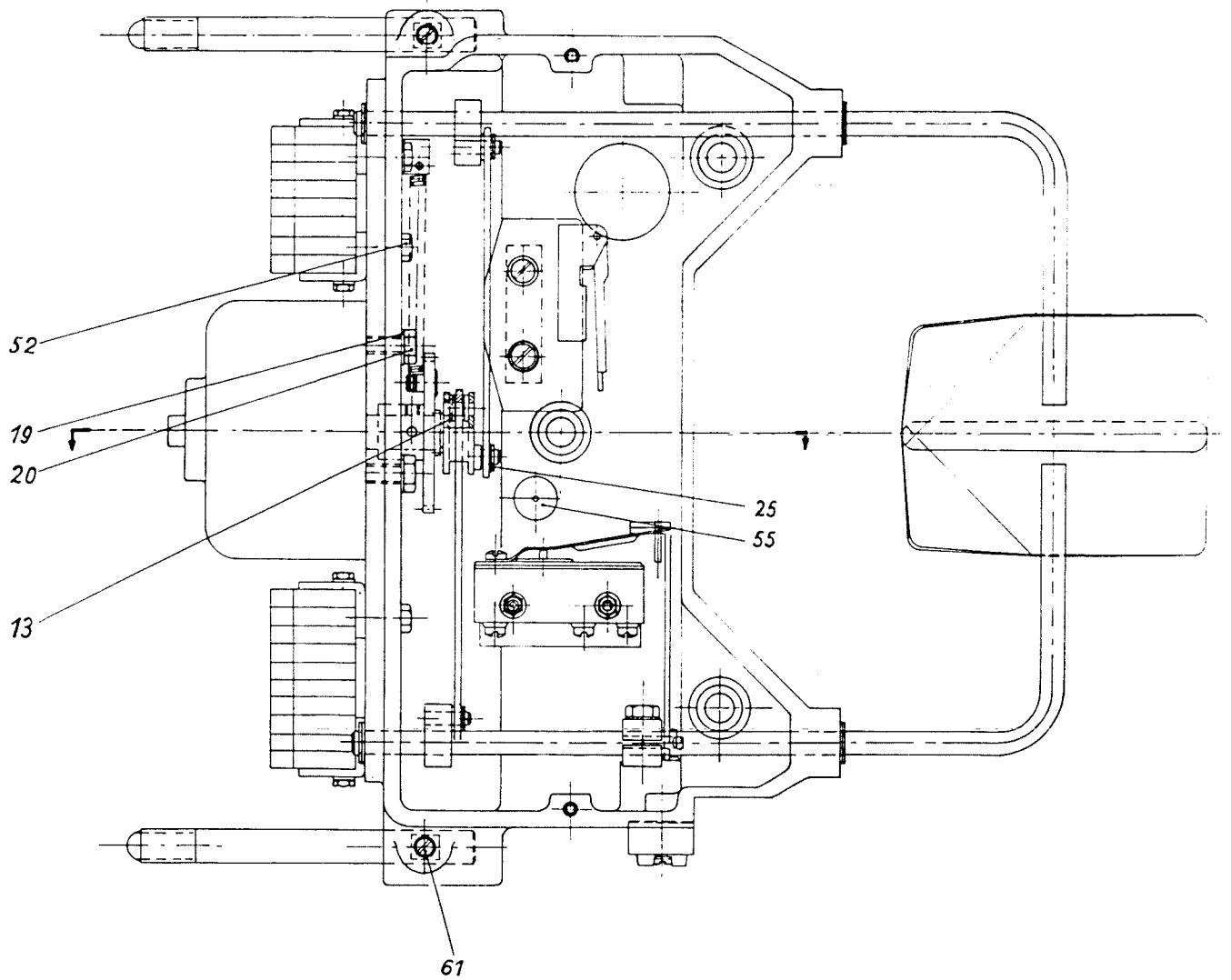
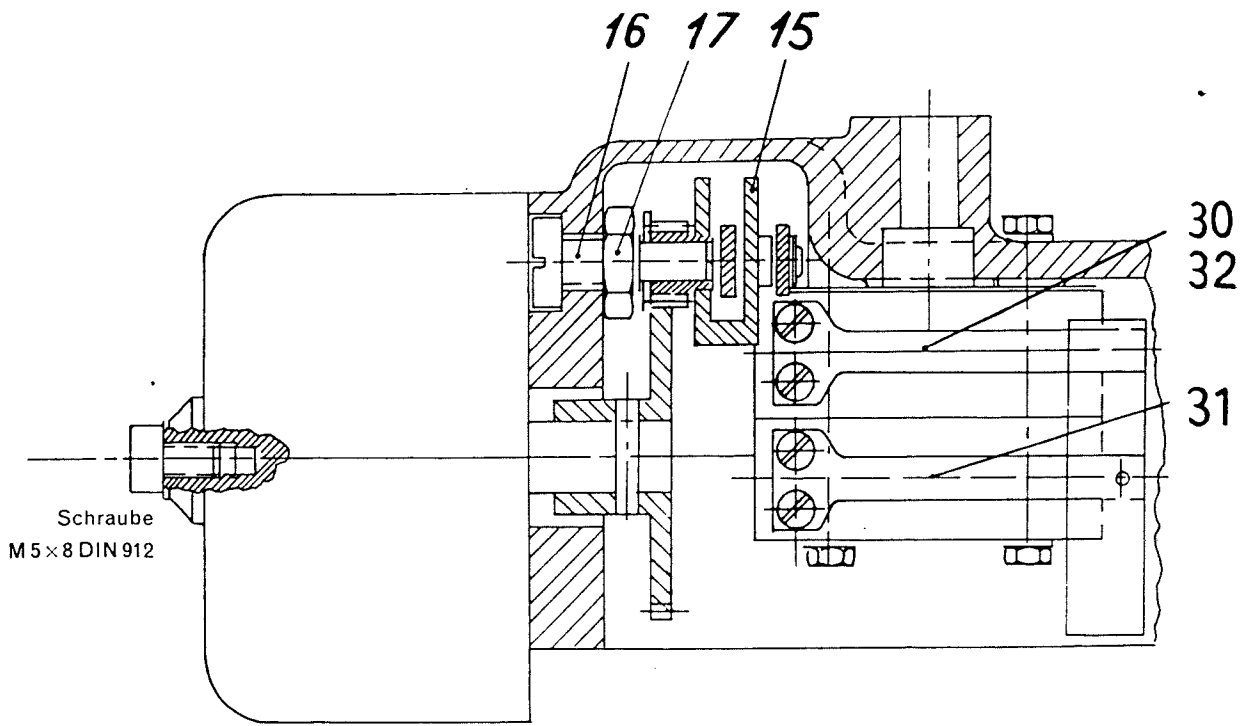

Lfd. Nr.	Stückzahl	ERSATZTEIL-LISTE	SPARE PART LIST	Bezeichnung
No.	qt.	Blendenschutz	Shutter housing	Order No.
1	1	Blendenschutz komplett	Shutter housing , complete	UW 2 GE 1/1 Z
2	2	Stehbolzen	stay bolts	UW 2 BO 7/1 X
3	2	Sechskantmuttern } für Blendenschutz	hexagon nuts } for shutter housing	M 10 DIN 934 ²¹⁴
4	1	Lichtschutzblech	heat shield	UW 2 MF 4/1 Z
5	4	Schrauben	screws	AM 4x15 DIN 91 ⁸²³
6	4	Scheiben	washers	4,3 DIN 125 ²¹⁴
7	4	Muttern	nuts	M 4 DIN 934 ²¹⁴
8	1	Einbaufassung	socket for pilot lamp	BL 8 FA 2/2 Z
9	1	Unterlage	insulating plate	BL 8 NF 2/1 X
10	1	Zylinderschraube	cylindrical screw	M 3x10 DIN 84 ²¹⁴
11	1	Scheibe	washer	3,2 DIN 125 ²¹⁴
12	1	Mutter	nut	M 3 DIN 934 ²¹⁴
13	1	Steckverbindungsleiste	plug connection	BW 14 EA 2/1 Z
14	1	Zylinderschraube	cylindrical screw	AM 3x15 DIN 84 ²¹⁴
15	1	Scheibe	washer	3,2 DIN 125 ²¹⁴
16	1	Spannstift	clamping pin	3x16 DIN 1481
17	2	Kontaktstifte	contact pins	BW 14 EA 1 1 X
18	1	Lichtschutzblech	heat shield	UW 2 M F 8 1 X
19	1	Lichtschutzblech	heat shield	UW 2 M F 7 1 X
20	1	Spannstift	clamping pin	5x14 DIN 1481
21	8	Linsensenkschrauben	screws with countersunk head	AM 4x12 DIN 91 ⁸²³
22	8	Scheiben	washers	4,3 DIN 125 ²¹⁴
23	8	Muttern	nuts	M 4 DIN 934 ²¹⁴
24	2	Rastfedern	lock springs	UW 2 FB 1/1 Z
25	2	Linsensenkschrauben	screws with countersunk head	AM 4x10 DIN 91 ⁸²³
26	2	Scheiben	washers	4,3 DIN 125 ²¹⁴
27	2	Muttern	nuts	BM 4 DIN 934 ²¹⁴
28	2	Spannstifte	clamping pins	2,5x8 DIN 1481
29	1	Soffittenlampe	pilot lamp	GL 43/1 Z
30	1	Blechwinkel	holder for pilot lamp	UW 2 M F 84/1 X

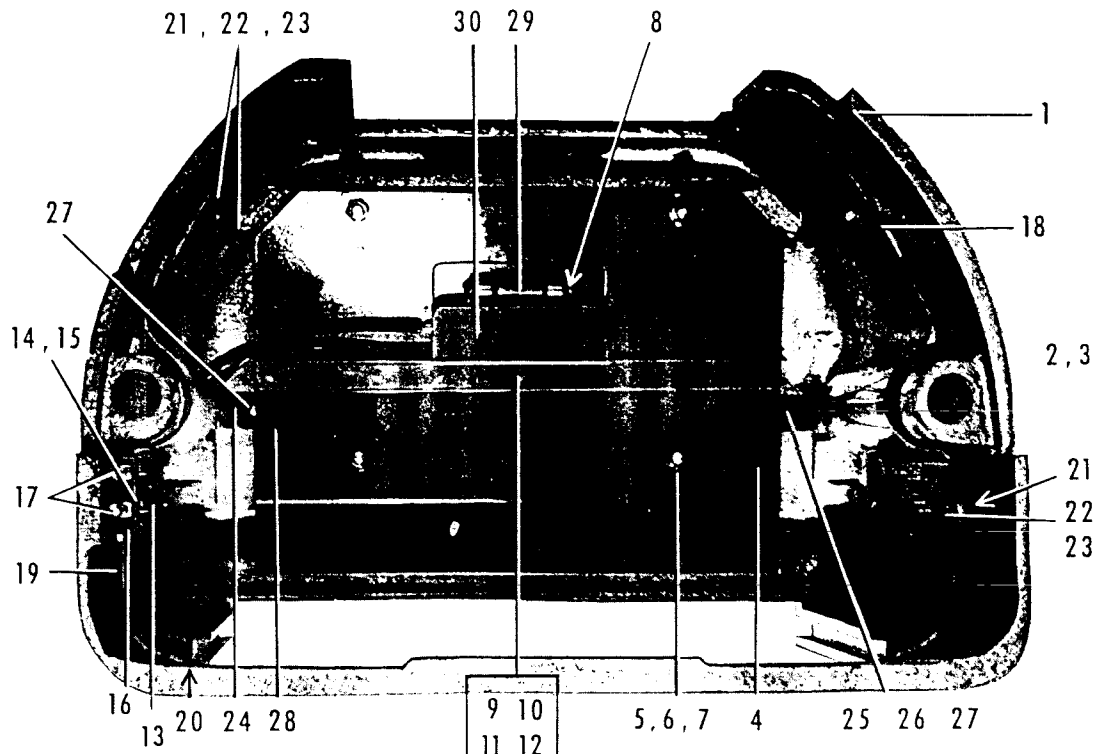

Lfd. Nr.	Stückzahl	Kenn-Nr. Mark. No.	ERSATZTEIL-LISTE	SPARE PART LIST	70 mm	35 mm
			Objektivfassung	Lens mounts		
1	1	1	Zwischentubus — I \varnothing 100 — A \varnothing 127, exzentrisch	lens adapter, eccentric	—	UW 2 FA 2/1 Z
2	1		Zwischentubus-Einzelteil	adapter, single part	—	UW 2 FA 2/1 X
3	1		Zylinderstift	cylindrical pin	—	4x18 DIN 7
4	1		Zapfenschraube	pin screw	—	SR 246/1 X
5	1		Innensechskantschraube in Pos. 1	hexagon socket screw	—	UW 2 SR 1/1 X
6	1	2	Anschlagring — I \varnothing 100 — A \varnothing 127, zentr.	stop ring	—	UW 2 MR 2/1 Z
7	1		Anschlagring-Einzelteil	stop ring, single part	—	UW 2 MR 2/1 X
8	1		Innensechskantschraube in Pos. 6	hexagon socket screw	—	UW 2 SR 1/1 X
9	1	3	Objektivfassung — I \varnothing 79,45 — A \varnothing 100 — kurz, exz.	lens mount, short type, eccentric	—	UW 2 FA 6/1 Z
10	1		Objektivfassung-Einzelteil	lens mount, single part	—	UW 2 FA 6/1 X
11	3		Innensechskantschrauben in Pos. 9	hexagon socket screws	—	UW 2 SR 2/1 X
12	1	4	Objektivfassung — I \varnothing 79,45 — A \varnothing 100 — lang, exz.	lens mount, long type, eccentric	—	UW 2 FA 7/1 Z
13	1		Objektivfassung-Einzelteil	lens mount, single part	—	UW 2 FA 7/1 X
14	3		Innensechskantschrauben i. Pos. 12	hexagon socket screws	—	UW 2 SR 2/1 X
15	1	5	Objektivfassung — I \varnothing 101,6 — A \varnothing 127 — zentr. lang, f. T-Kiptagon	lens mount, centric, long for T-Kiptagon	UW 2 FA 3/1 Z	—
16	1		Objektivfassung-Einzelteil	lens mount, single part	UW 2 FA 3/1 X	—
17	1		Zylinderstift in Pos. 15	cylindrical pin	4x18 DIN 7	—
18	1		Innensechskantschraube in Pos. 15	hexagon socket screw	UW 2 SR 1/1 X	—
19	1	6	Objektivfassung — I \varnothing 101,6 — A \varnothing 127 — zentr. kurz, f. T-Kiptagon	lens mount, centric, short for T-Kiptagon	UW 2 FA 4/1 Z	—
20	1		Objektivfassung Einzelteil	lens mount, single part	UW 2 FA 4/1 X	—
21	1		Zylinderstift in Pos. 19	cylindrical pin	4x18 DIN 7	—
22	1		Innensechskantschraube in Pos. 19	hexagon socket screw	UW 2 SR 1/1 X	—
23	1	7	Objektivfassung — I \varnothing 101,6 — A \varnothing 127 — exz., f. Super Kiptar S	lens mount, eccentric, for Super Kiptar S	—	UW 2 FA 8/1 Z
24	1		Objektivfassung Einzelteil	lens mount, single part	—	UW 2 FA 8/1 X
25	1		Zylinderstift in Pos. 23	cylindrical pin	—	4x18 DIN 7
26	1		Innensechskantschraube in Pos. 23	hexagon socket screw	—	UW 2 SR 1/1 X
27	1	8	Zwischentubus — I \varnothing 117x132 — A \varnothing 127x145x158 — f. gr. Ent- zerrungsvorsatz	lens adapter for large hypergonar	—	UW 2 FA 1/1 Z
28	1		Zwischentubus Einzelteil	lens adapter, single part	—	UW 2 FA 1/1 X
29	1		Zylinderstift in Pos. 27	cylindrical pin	—	4x6 DIN 7
30	1		Zylinderstift in Pos. 27	cylindrical pin	—	4x12 DIN 7
31	1		Innensechskantschraube f. gr. Entzerrungsvorsatz i. Pos. 27	hexagon socket screw for large hypergonar	—	UW 2 SR 1/1 X
32	1	9	Anschlagring — I \varnothing 132 — A \varnothing 158, f. gr. Entzerrungsvorsatz	stop ring for large hypergonar	—	UW 2 MR 1/1 Z
33	1		Anschlagring Einzelteil	stop ring, single part	—	UW 2 MR 1/1 X
34	1		Innensechskantschraube in Pos. 32	hexagon socket screw	—	UW 2 SR 1/1 X
35	1	10	Objektivfassung — I \varnothing 101,6x120,8 — A \varnothing 117x132x152, f. gr. Entzerrungsvorsatz	lens mount for large hypergonar	—	UW 2 FA 5/1 Z
36	1		Objektivfassung Einzelteil	lens mount, single part	—	UW 2 FA 5/1 X
37	2		Schrauben in Pos. 35	screws	—	MBSR 10/1 X
38	1		Innensechskantschraube in Pos. 35	hexagon socket screw	—	UW 2 SR 1/1 X

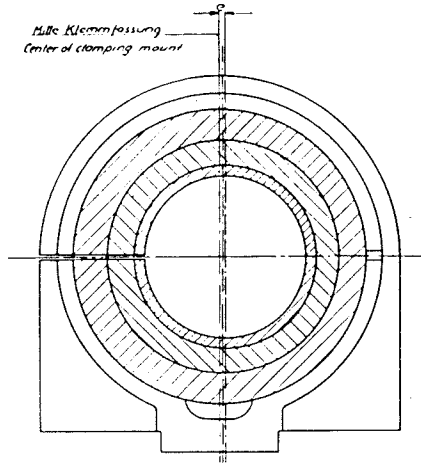

Diese Zusammenstellung gilt für 62,5 bzw. 70,7 mm-Objektive von:
This complete plan refers to 62,5 or 70,7 mm lenses for:
 Normalbild: $e = 125$ mm (gezeichnete Stellung, ohne Hypergonar) $f = 60 - 160$ mm
 Standard picture: $e = 125$ mm (illustrated position, without Hypergonar) $f = 60 - 160$ mm
 Breitbild: $e = 125$ mm (gezeichnete Stellung, ohne Hypergonar) $f = 60 - 160$ mm
 wide screen picture: $e = 125$ mm (illustrated position, without Hypergonar) $f = 60 - 160$ mm
 C-LT: $e = 125$ mm (gezeichnete Stellung) bis $f = 170$ mm
 Cinemascope optical sound: $e = 125$ mm (illustrated position) up to $f = 170$ mm
 C-MT: $e = 0,48$ mm (Objektivfassung UW2 FA 6/12 um 180° gedreht) bis $f = 110$ mm
 Cinemascope magnetic sound: $e = 0,48$ mm (lens mount UW2 FA 6/12 turned by 180 deg) up to $f = 110$ mm

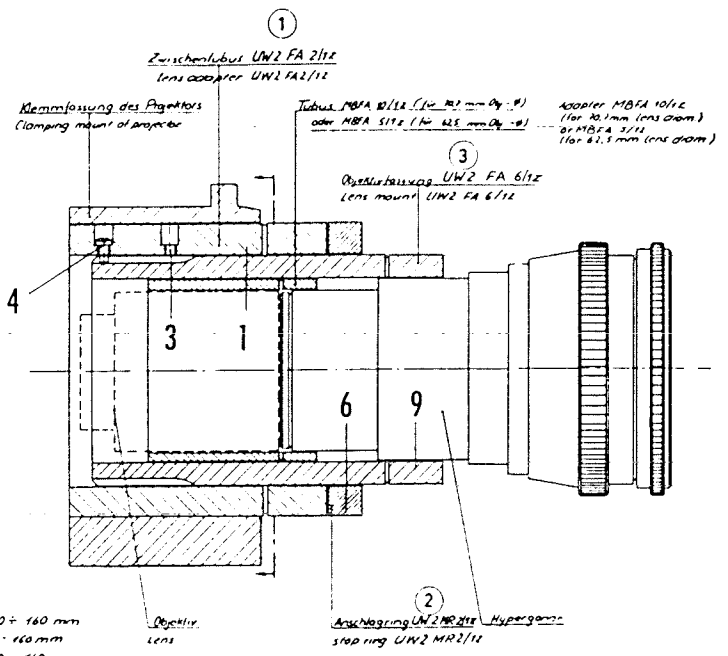

Nummern im Kreis sind auf der Stirnseite jedes Objektivfassungsteils angegraviert.
 Figures in circle are engraved on face side of each lens mount part.

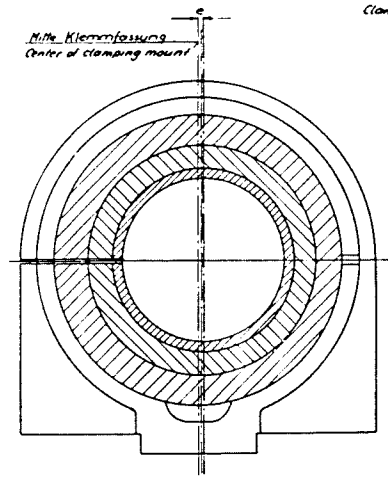

C-LT: $e = 125$ mm (gezeichnete Stellung)
 Cinemascope optical sound: $e = 125$ mm (illustrated position)
 C-MT: $e = 0,48$ mm (Objektivfassung UW2 FA 7/12 um 180° gedreht)
 Cinemascope magnetic sound: $e = 0,48$ mm (lens mount UW2 FA 7/12 turned by 180 deg)

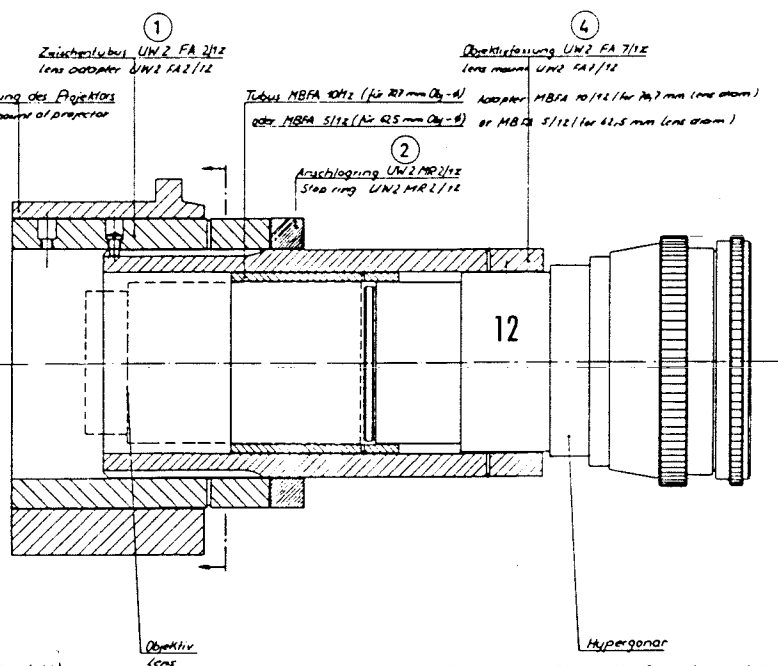

Nummern im Kreis sind auf der Stirnseite jedes Objektivfassungsteils angegraviert.
 Figures in circle are engraved on face side of each lens mount part.

Diese Zusammenstellung gilt nur für C-LT bzw. C-MT mit
Brennweite über $f = 110$ mm bei 62,5 und 70,7 mm-Objektiven!
This complete plan refers only to Cinemascope optical sound or Cinemascope magnetic sound with
focal length of more than $f = 110$ mm with 62,5 and 70,7 mm lenses!

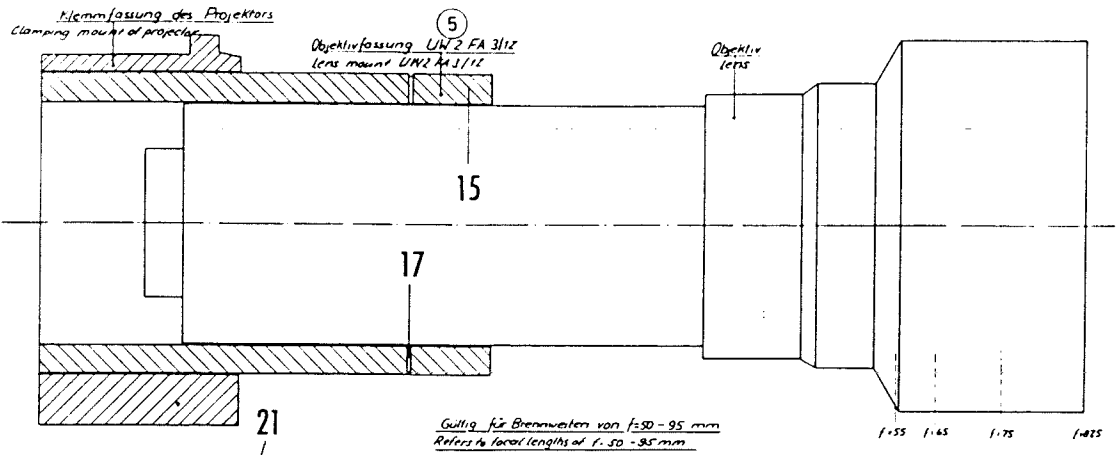

Zusammenstellung für 20mm-Film mit T-Kipplage
Complete plan for 20 mm film with T-tilt

Nummern im Kreis sind auf der Stirnseite jedes Objektivfassungsteils eingraviert
 Figures in circle are engraved on face side of each lens mount part

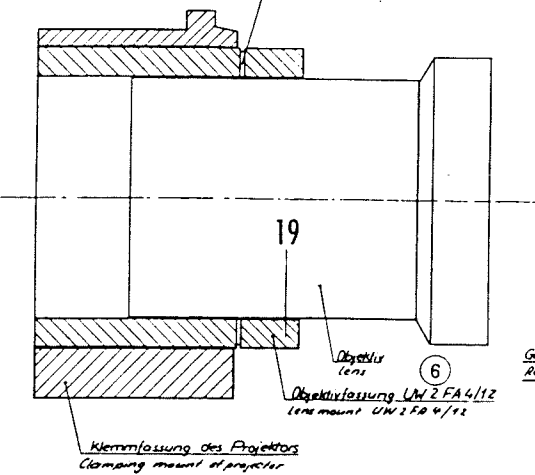

Gültig für Brennweiten von f=100-175 mm
Refers to focal lengths of f=100-175 mm

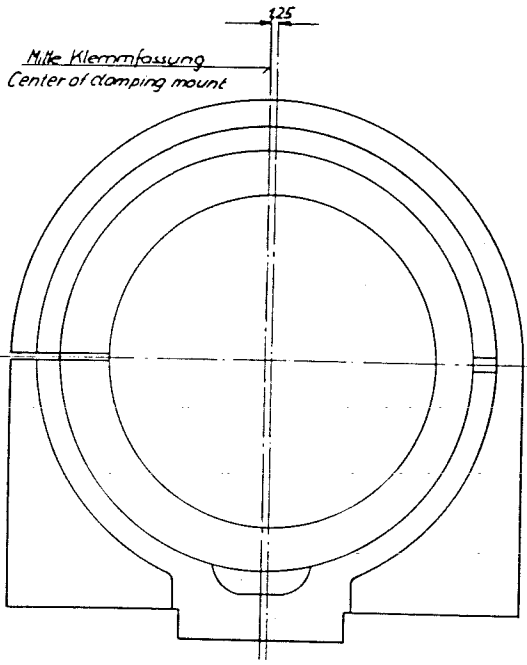

Klemmfassung des Projektors
Clamping mount of projector

Objektivfassung UW 2 FA 8/12
Lens mount UW 2 FA 8/12

Figures in circle are engraved on face side of each lens mount part.

Nummern im Kreis sind auf der Stirnseite jedes Objektivfassungsteils eingraviert

Zusammenstellung für Normalbild und Breitbild
bei 101,6 mm (4") - Objektiven!
Complete plan for standard picture and wide screen picture
with 101,6 mm (4") - lenses!

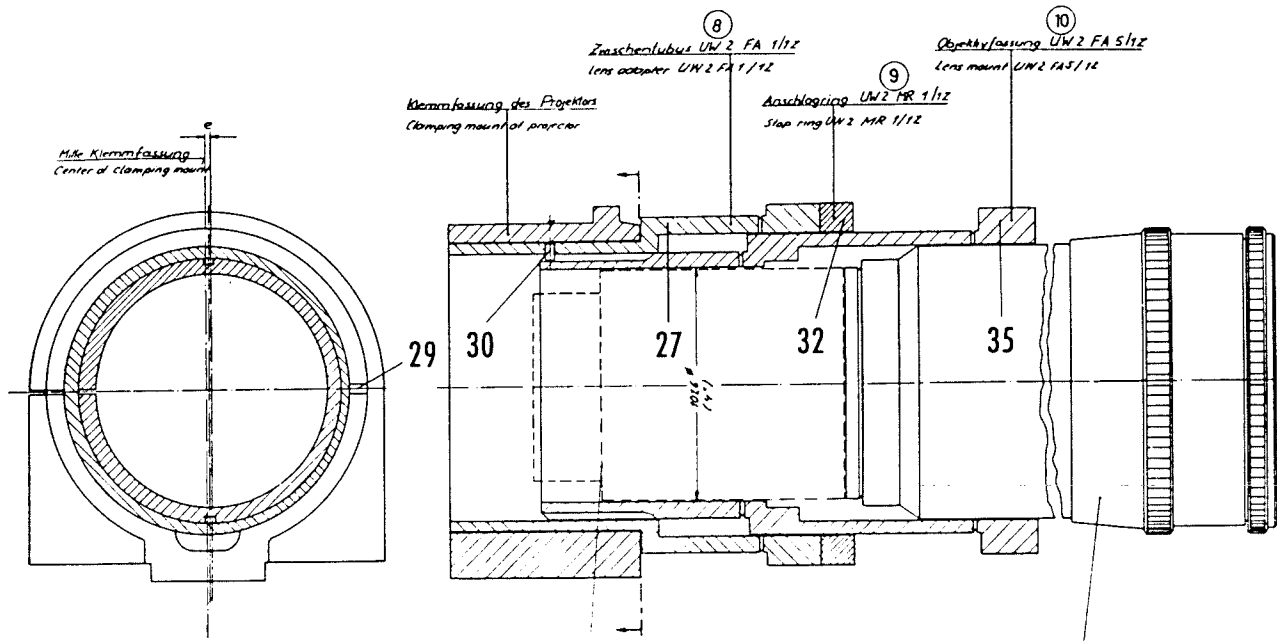

C-LT : $e = 125$ mm (gerade Stellung)
 Cinemascope optical sounder 125 mm (illustrated position)
 C-MT : $e = 148$ mm (innerste Fassung um 180° gedreht)
 Cinemascope magnetic sounder $e = 148$ mm (innermost mount turned by 180 deg)

Diese Zusammenstellung gilt nur für C-LT bzw. C-MT.
 This complete plan refers only to Cinemascope optical sounder
 or Cinemascope magnetic sounder with 101.6 mm (4")-lenses!

Figures in circle are engraved on face side
 of each lens mount part.
 Nummern im Kreis sind auf der Stirnseite jedes Objektivfassungsteils eingraviert.

Lfd. Nr.	Stückzahl	ERSATZTEIL-LISTE	SPARE PART LIST	Standard-Ausführung	U. S. A.-Type
No.	qt.	Lichttongerät	Optical sound head		
1	1	Lichttongerät	Optical sound head	UT 2 R 1	UT 2 R 2
2	3	Innensechskantschrauben	hexagon socket screws	M 8 x 65 DIN 912 ⁹³³	M 8 x 65 DIN 912 ⁹³³
3	1	Winkel	angle shaped piece	UW 2 MF 60/1 X	UW 2 MF 60/1 X
4	1	Innensechskantschr.	hexagon socketscrew	M 8 x 18 DIN 912 ⁹³³	M 8 x 18 DIN 912 ⁹³³
5	2	Spannstifte	clamping pins	3 x 14 DIN 1481	3 x 14 DIN 1481
6	1	Fotozelle	photo cell	LTG 125/3 ... Z	LTG 125/3 ... Z
7	1	Tonlampe	exciter lamp	GL 55/1 Z	GL 55/1 Z
8	1	Fotozellenkabel (Meterware)	photo-cell cable	BKA 47/0,7	BKA 47/0,7
9	1	Fotozellenhalter	photo cell holder	BT 14 FA 1/1 Y	UT 2 FA 1/1 X
10	1	Kontaktfeder	contact spring	BT 14 FB 3/1 X	—
11	2	Niet	rivets	1,4 x 5 DIN 660 A 1	—
12	1	Spannstift	clamping pin	2 x 6 DIN 1481	2 x 6 DIN 1481
13	2	Isolierbuchsen für Schrauben	insulating bushes for screws	BT 14 NB 2/1 X	BT-14 NB 2/1 X
14	2	Isolierbuchsen für Stifte	insulating bushes for pins	TANB 2/1 X	TANB 2/1 X
15	2	Schrauben	screws	M 6 x 15 DIN 84 ⁹³³	M 6 x 15 DIN 84 ⁹³³
16	2	Stifte	pins	3 x 15 DIN 7	3 x 15 DIN 7
17	1	Isolierplatte	insulating plate	BT 14 PT 2/1 X	BT 14 PT 2/1 X
18	1	Druckplatte	tensioning plate	BT 14 PT 3/1 X	—
19	2	Schrauben für Druckplatte	screws for tensioning plate	M 3 x 6 DIN 63 ⁹³⁴	—
20	1	Nietbolzen mit Kontaktfeder für Fotozelle	rivet with contact spring for photo-cell	BT 14 BO 2/1 Z	—
21	1	Isolierbuchse	insulating bush	BT 14 NB 1/1 X	—
22	1	Mutter	nut	M 4 DIN 439 ³¹⁴	M 4 DIN 439 ³¹⁴
23	1	abgeschirmtes Kabel	screened cable	BT 14 KA 2/1 Z	UT 2 KA 1/1 Z
24	1	Erdungskabel	grounding cable	—	UT 2 KA 3/1 Z
25	1	Schraube	screw	M 3 x 8 DIN 91 ⁹³³	M 3 x 8 DIN 91 ⁹³³
26	1	Federscheibe	spring washer	B 3 DIN 127	B 3 DIN 127
27	1	Mutter	nut	M 3 DIN 934 ⁹³⁴	—
28	1	Schraube	screw	—	UT 2 SR 1/1 X
29	1	Fotozellenhalter	photo-cell holder	—	UT 2 FA 2/1 X
30	1	Zylinderstift	cylindrical pin	—	2,5 x 8 DIN 7
31	1	Socket für Fotozelle	socket for photo cell	—	UT 2 EA 3/1 Z
32	4	Gummitüllen	rubber sleeves	—	PBNF 17/1 X
33	2	Linsenschrauben	flat-head screw	—	M 3 x 8 DIN 85 ⁹³³
34	1	Schraube	screw	—	UT 2 SR 2/1 X
35	2	Scheibe	washers	—	3,2 DIN 125 ⁹³³
36	2	Rohrschellen	pipe clips	RS 1/1 X	RS 1/1 X
37	2	Schrauben	screws	M 4 x 5 DIN 84 ³¹⁴	M 4 x 5 DIN 84 ³¹⁴
38	1	Spaltoptikhalter	holder für slit optic	BT 14 FA 2/1 X	BT 14 FA 2/1 X
39	2	Schrauben	screws	M 4 x 15 DIN 85 ⁹³³	M 4 x 15 DIN 85 ⁹³³
40	2	Stifte	pins	3 x 12 DIN 7	3 x 12 DIN 7
41	1	Spaltobjektiv	slit optic	RF 111/3 Z	RF 111/3 Z
42	1	Schraube	screw	M 5 x 16 DIN 84 ³¹⁴	—
43	1	Mikroschalter	micro switch	UA 2 SH1/1 Z	—
44	1	Isolierplatte	insulating plate	UT 2 PT 1/1 X	—
45	2	Schrauben	screws	M 3 x 20 DIN 91 ⁹³³	M 3 x 10 DIN 91 ⁹³³
46	2	Muttern	nuts	M 3 DIN 934 ⁹³⁴	M 3 DIN 934 ⁹³⁴
47	2	Scheiben	washers	3,2 DIN 125 ⁹³³	3,2 DIN 125 ⁹³³
48	1	Lüsterklemme	terminal block	WN 31 EA 1/2 Z	WN 31 EA 1/2 Z
49	1	Schraube	screw	M 3 x 20 DIN 84 ³¹⁴	—
50	1	Mutter	nut	M 3 DIN 934 ³¹⁴	—
51	1	Sperrschieber	stop slider	UT 2 MF 2/1 Z	—
52	3	Scheiben	washers	MS 26/8 X	—
53	1	Federscheibe	spring washer	UT 2 MS 2/1 X	—
54	1	Seegersicherung	spring clip	12 x 1 DIN 471	—
55	1	Rändelknopf (Schraube)	knurled head (screw)	UT 2 HG 1/1 Z	M 4 x 10 DIN 85 ⁹³³
56	1	Zylinderstift zu Pos. 55	cylindrical pin	2 x 6 DIN 7	—
57	1	Distanzring	distance ring	UT 2 MR 8/1 X	—
59	2	Scheiben	washers	5,3 DIN 125 ³¹⁴	—
60	1	Federscheibe	spring washer	MS 174/1 X	4,3 DIN 125 ³¹⁴
61	1	Schaltstück (Mutter)	nut	UT 2 MF 4/1 X	M 4 DIN 934 ³¹⁴

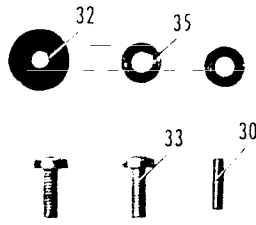
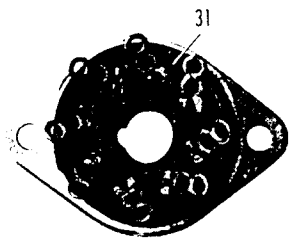
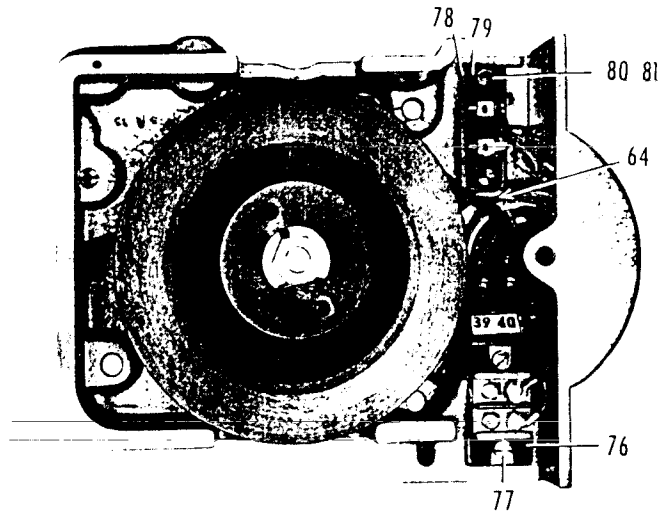
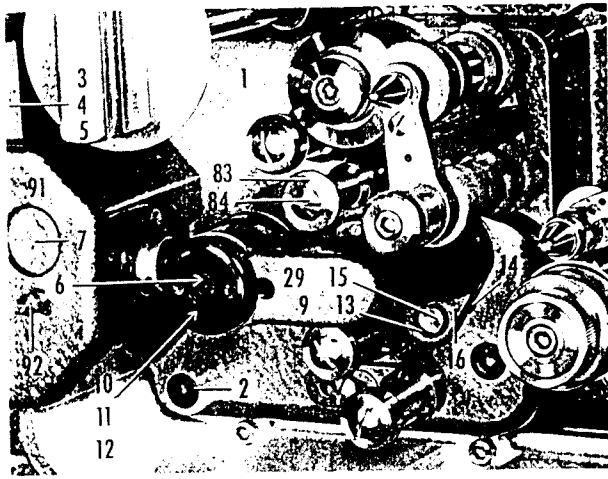

87 86 88

82 90 89

85

23

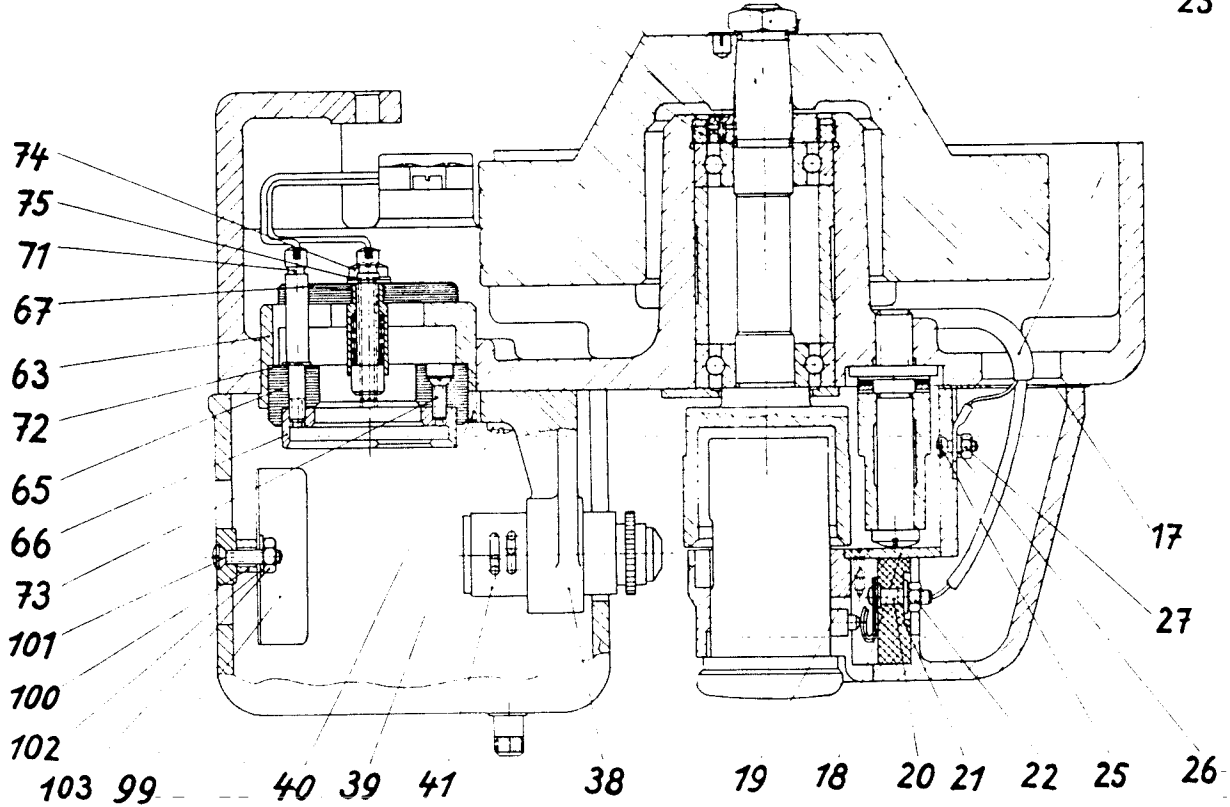

Lfd. Nr.	Stückzahl	ERSATZTEIL-LISTE	SPARE PART LIST	Standard-Ausführung	U.S.A.-Type
No.	qt.	Lichttongerät	Optical sound head		
62	1	Schraube	screw	M 3×7 DIN 933 ³¹⁴	—
63	1	Reduzierring	reducing ring	UT 2 MR 1/1 X	UT 2 MR 2/1 X
64	4	Schrauben	screws	M 4×12 DIN 91 ⁸³³	M 4×12 DIN 91 ⁸³³
65	1	Isoliering	insulating ring	TBNR 1/1 X	—
66	1	Fassungsring (Fassung)	mounting ring	TBEA 7/1 Z	UT 2 EA 2/1 Z
67	1	Isolierscheibe mit Kontakt	insulating washer with contact	BT 14 NS 1/1 Z	—
68	1	Kontaktbolzen	contact pin	TBEA 6/1 X	—
69	1	Feder	spring	TBFS 5/1 X	—
70	1	Bz-Scheibe	washer	5 DIN 6799	—
71	1	Anschlußbolzen	connecting bolt	TBEA 5/1 X	—
72	6	Federringe	spring rings	B 4 DIN 127	4 pieces
73	3	Senkschrauben	counter sunk screws	M 4×12 DIN 63 ³¹⁴	—
74	2	Schrauben	screws	M 5×28 DIN 85 ³¹⁴	M 2,6×16 DIN 85 ⁸³³
75	2	Federscheiben	spring washers	B 5 DIN 127	—
76	1	Anschlußleiste	connection block	EA 60/2 Z	EA 60/2 Z
77	2	Zylinderschrauben	cylindrical screws	M 4×14 DIN 84 ³¹⁴	M 4×14 DIN 84 ³¹⁴
78	1	Unterlage	washer	UT 2 NF 1/1 X	UT 2 NF 1/1 X
79	1	Anschlußleiste	connection block	BT 14 EA 1/1 Z	UT 2 EA 1/1 Z
80	2	Distanzringe	distance rings	BT 14 MR 3/1 X	BT 14 MR 3/1 X
81	2	Schrauben	screws	M 4×14 DIN 84 ³¹⁴	M 4×14 DIN 84 ³¹⁴
82	1	Tonbahnachse	sound-drum shaft	BT 14 AC 1/1 Z	BT 14 AC 1/1 Z
83	1	Deckel	cover	MS 129/2 X ⁸³³	MS 129/2 X ⁸³³
84	4	Schrauben	screws	M 4×10 DIN 87 ⁸³³	M 4×10 DIN 87 ⁸³³
85	2	Kugellager	ball bearings	KL 4/5 Z	KL 4/5 Z
86	1	Klemm-Mutter	clamp nut	TBMU 1/1 X ³¹⁴	TBMU 1/1 X ³¹⁴
87	1	Gewinding	threaded ring	BT 14 MR 2/1 X	BT 14 MR 2/1 X
88	1	Senkschraube	counter sunk screw	M 3×5 DIN 63 ³¹⁴	M 3×5 DIN 63 ³¹⁴
89	1	Sicherungsblech	insulating shield	10,5 DIN 432	10,5 DIN 432
90	1	Mutter	nut	M 10×1 DIN 936	M 10×1 DIN 936
91	1	Tonlampenkappe	cap for exciter lamp	UT 2 DE 1/1 X	UT 2 DE 1/1 X
92	2	Stehbolzen f. Kappe	stay bolts for cap	BT 14 BO 3/1 X	BT 14 BO 3/1 X
93	1	Rändelgriff	knurled knob	BT 14 HG 1/1 X	BT 14 HG 1/1 X
94	1	Scheibe	washer	MS 12/3 X ⁸³³	MS 12/3 X ⁸³³
95	1	Verschußklappe	sleevable shield	BT 14 MF 1/1 X	BT 14 MF 1/1 X
96	1	Zwischenscheibe	intermediate washer	MS 13/3 X ³¹⁴	MS 13/3 X ³¹⁴
97	1	Federscheibe	spring washer	A 6 DIN 137 ³¹⁴	A 6 DIN 137 ³¹⁴
98	1	Bz-Scheibe	clamping washer	5 DIN 6799 ³¹⁴	5 DIN 6799 ³¹⁴
99	1	Lichtschutzblech	heat shield	UT 2 MF 1/1 X	UT 2 MF 1/1 X
100	2	Distanzringe	distance ring	UT 2 MR 7/1 X	UT 2 MR 7/1 X
101	2	Schrauben	screws	M 3×15 DIN 91 ⁸³³	M 3×15 DIN 91 ⁸³³
102	2	Federringe	spring rings	B 3 DIN 127 ⁸⁴⁴	B 3 DIN 127 ⁸⁴⁴
103	2	Muttern	nuts	M 3 DIN 934 ⁸⁴⁴	M 3 DIN 934 ⁸⁴⁴
104	1	Zu Stellhebel (Pos. 42, 1. Liste)	for lever (pos. 42, 1. list)		
		Scheibe	1 washer	MS 66/8 X	MS 66/8 X
105		Andruckhebel	pression lever	UT 2 HE 1/1 X	UT 2 HE 1/1 X

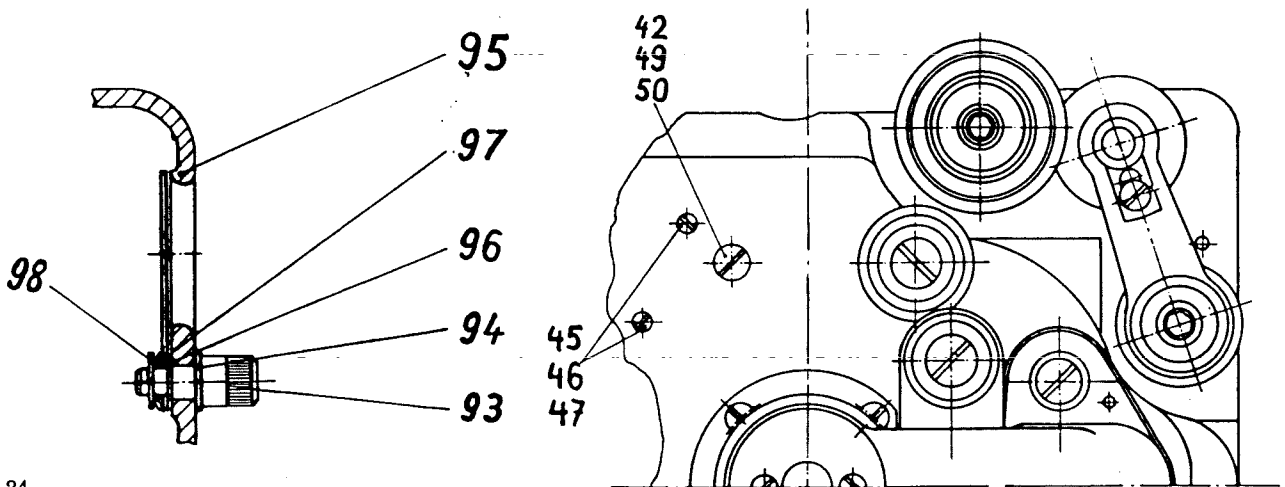

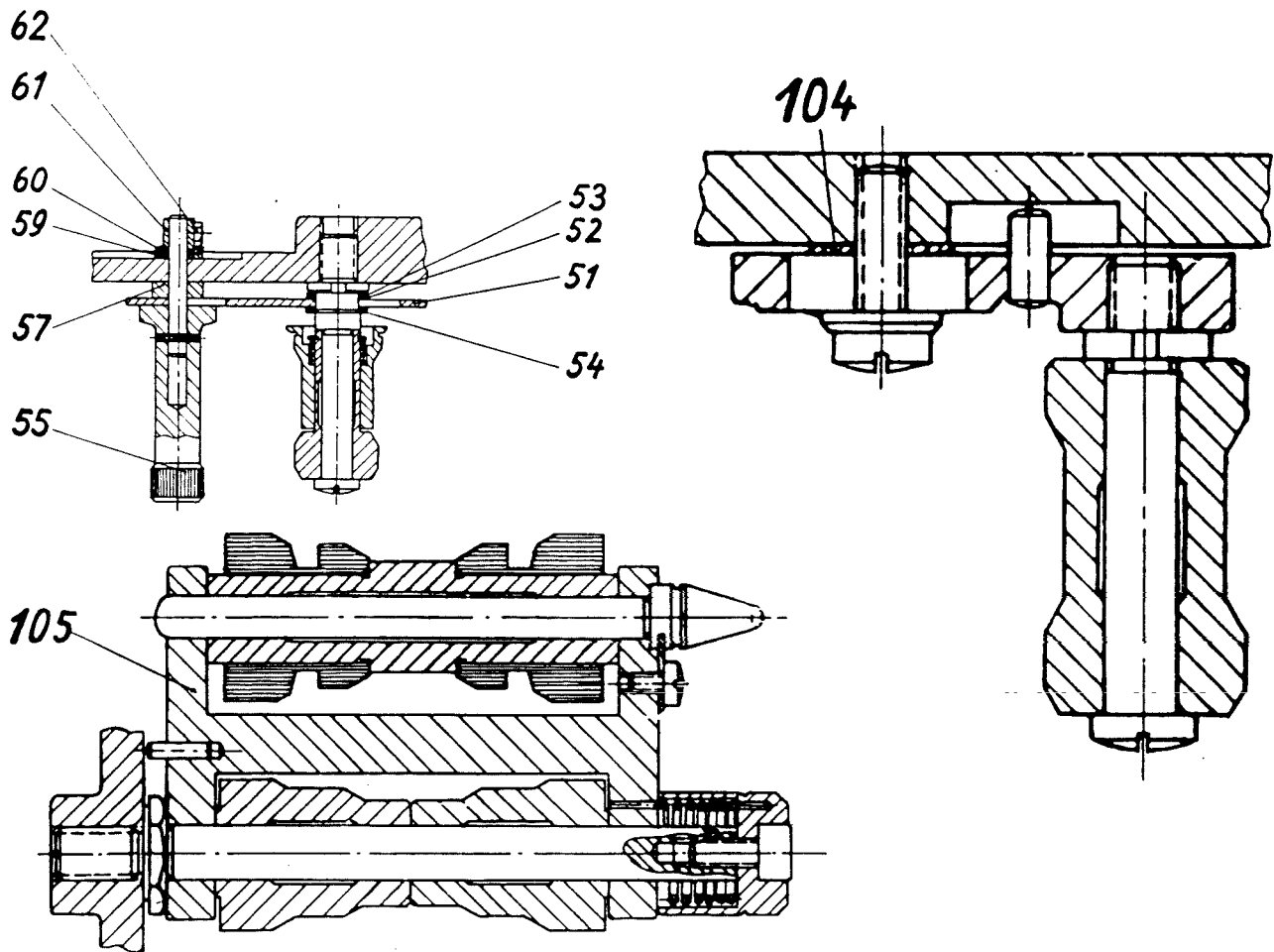
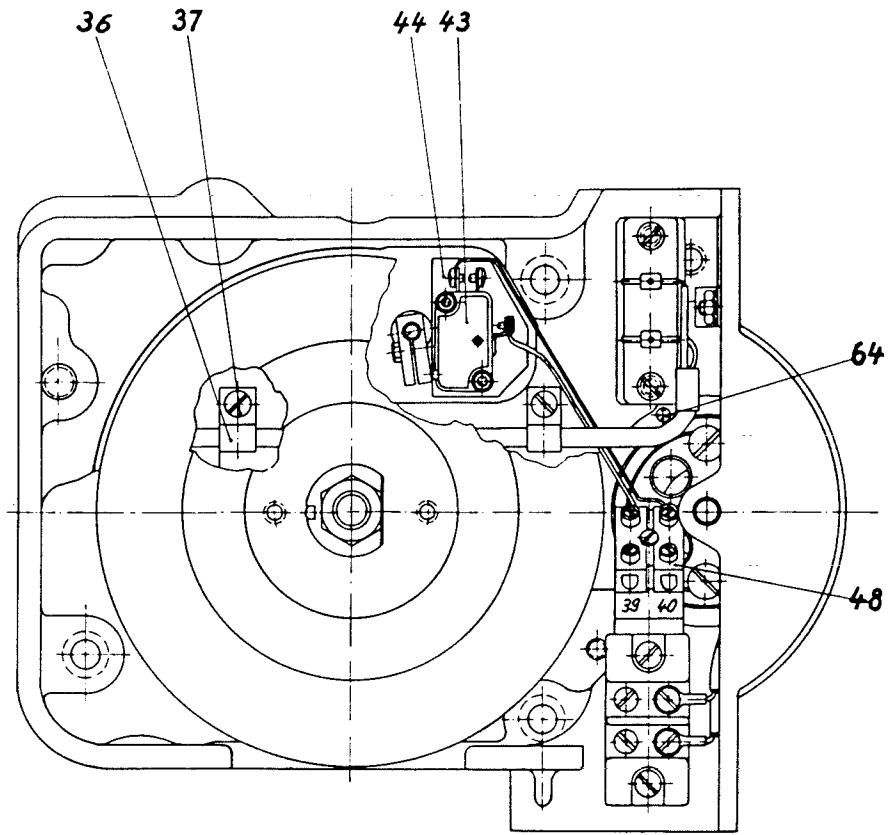

Lfd. Nr.	Stückzahl	ERSATZTEIL-LISTE		SPARE PART LIST		
		Säule mit Tischplatte	Pedestal with table plate	Drehstrom		115 V 60 Hz
No.	qt.			380 V 50 Hz	220 V 50 Hz	
1	1	Fuß	pedestal	UF 2 ST 1 R 200/1	UF 2 ST 1 R 100/2	UF 2 ST 1 R 150/2
2	4	Stellbolzen Justie-	stay bolts adjust-	UW 2 B 04/1 Z	UW 2 B 04/1 Z	UW 2 B 04/1 Z
3	4	Gewindestifte rung	threaded pins ment	IBSR 1/1 X	IBSR 1/1 X	IBSR 1/1 X
4	1	Klemmleiste	terminal panel	UF 2 MF 9/1 Z	UF 2 MF 9/1 Z	—
5	2	Schrauben	screws	M 5 × 12 DIN 91 ⁴³³	M 5 × 12 DIN 91 ⁴³³	M 5 × 12 DIN 91 ⁴³³
6	2	Muttern	nuts	—	—	M 5 DIN 934 ⁴³⁴
7	2	Anschlußklemmen	terminals	UF 2 EA 2/1 Z	UF 2 EA 2/1 Z	—
8	2	Halteschrauben	fastening screws	M 5 × 10 DIN 84 ⁴³⁴	M 5 × 10 DIN 84 ⁴³⁴	—
9	5	Schrauben f. Blechkasten	screws for metal box	M 6 × 8 DIN 85 ³¹⁴	M 6 × 8 DIN 85 ³¹⁴	M 6 × 8 DIN 85 ³¹⁴
10	2	Scharniere	hinges	BF 15 GK 1/1 X	BF 15 GK 1/1 X	BF 15 GK 1/1 X
11	2	Schrauben	screws	M 6 × 12 DIN 85 ³¹⁴	M 6 × 12 DIN 85 ³¹⁴	M 6 × 12 DIN 85 ³¹⁴
12	7	Schrauben für Abdeckplatte	screws for cover plate	M 6 × 12 DIN 88 ⁴³³	M 6 × 12 DIN 88 ⁴³³	M 6 × 12 DIN 88 ⁴³³
13	7	U. Scheiben f. Abdeckplatte	washers for cover plate	BF 14 MS 1/1 X	BF 14 MS 1/1 X	BF 14 MS 1/1 X
14	1	Achse	shaft	BF 15 AC 1/1 X	BF 15 AC 1/1 X	BF 15 AC 1/1 X
15	1	Führungsstange (senkr.)	guide rail (vertical)	BF 15 BO 1/1 X	BF 15 BO 1/1 X	BF 15 BO 1/1 X
16	1	Bolzen	bolt	IBBO 3/1 X	IBBO 3/1 X	IBBO 3/1 X
17	2	Sicherungsscheiben	lock washers	9 DIN 6799	9 DIN 6799	9 DIN 6799
18	1	Schiebebolzen	sliding pin	BF 14 BO 2/1 X	BF 14 BO 2/1 X	BF 14 BO 2/1 X
19	1	Gewindestift (Führungsstange)	threaded pin (guiding rail)	IBSR 1/1 X	IBSR 1/1 X	IBSR 1/1 X
20	1	Gewindestift (Auge, Säule)	threaded pin (eye, pedestal)	IBSR 2/1 X	IBSR 2/1 X	IBSR 2/1 X
21	1	Gewindestift (Auge, Tischpl.)	threaded pin (eye, table-plate)	IBSR 3/1 X	IBSR 3/1 X	IBSR 3/1 X
22	1	Schalterplatte	switch pannel	BF 14 PT 10/1 Z	BF 14 PT 10/1 Z	UF 2 PT 1/1 Z
23	12	Schrauben f. Schalter-	screws for switch-	M 6 × 12 DIN 88 ⁴³³	M 6 × 12 DIN 88 ⁴³³	M 6 × 12 DIN 88 ⁴³³
24	12	Unterleg- u. Abdeck- scheiben platte	washers and cover plate	BF 14 MS 1/1 X	BF 14 MS 1/1 X	BF 14 MS 1/1 X
25	1	Druckknopfaster (Lampe aus)	push button (lamp off)	BF 14 SH 4/1 Z	BF 14 SH 4/1 Z	BF 14 SH 4/1 Z
26	1	Druckknopfaster (Gefahr)	push button (emergency)	BF 11 SH 1/3 Z	BF 11 SH 1/3 Z	BF 11 SH 1/3 Z
27	2	Druckknopfaster (Motor und Lampe ein)	push buttons (motor and lamp on)	BF 11 SH 1/1 Z	BF 11 SH 1/1 Z	1 piece
28	1	Druckknopfaster (Überblendung)	push button (change-over)	BF 11 SH 1/4 Y	BF 11 SH 1/4 Y	—
29	1	Druckknopfaster (Motor aus)	push button (motor off)	BF 11 SH 1/2 Z	BF 11 SH 1/2 Z	BF 11 SH 1/2 Z
30	1	Druckknopfaster (Tipper)	push button (tipper)	BF 14 SH 2/2 Z	BF 14 SH 2/2 Z	BF 14 SH 2/2 Z
31	2	Kippschalter	tumbler switches	SH 81/1 Z	SH 81/1 Z	UF 2 SH 4/1 Z
32	4	Schrauben	screws	M 3 × 9 DIN 91 ⁴³³	M 3 × 9 DIN 91 ⁴³³	—
33	4	Muttern	nuts	M 3 DIN 934 ³¹⁴	M 3 DIN 934 ³¹⁴	—
34	1	Mikroschalter [Überbl.]	micro switch	BF 14 SH 5/1 Z	BF 14 SH 5/1 Z	BF 14 SH 5/1 Z
35	1	Bolzen	pin	BW 14 BO 52/1 X	BW 14 BO 52/1 X	BW 14 BO 52/1 X
36	1	Winkel	elbow	BF 14 MF 7/1 X	BF 14 MF 7/1 X	BF 14 MF 7/1 X
37	1	Isolierplatte	insulating plate	BF 14 NF 1/1 X	BF 14 NF 1/1 X	BF 14 NF 1/1 X
38	2	Schrauben	screws	M 3 × 25 DIN 84 ³¹⁴	M 3 × 25 DIN 84 ³¹⁴	M 3 × 25 DIN 84 ³¹⁴
39	2	Federscheiben	spring washers	B 3 DIN 127 ³¹⁴	B 3 DIN 127 ³¹⁴	B 3 DIN 127 ³¹⁴
40	2	Muttern	nuts	M 3 DIN 934 ³¹⁴	M 3 DIN 934 ³¹⁴	M 3 DIN 934 ³¹⁴
41	4	Klemmleisten	terminal strips	WN 31 EA 1/7 Z	WN 31 EA 1/7 Z	WN 31 EA 1/7 Z
42	2	Klemmleisten	terminal strips	—	—	WN 31 EA 1/8 Z
43	8	Schrauben	screws	M 3 × 20 DIN 84 ³¹⁴	M 3 × 20 DIN 84 ³¹⁴	4 pieces
44	8	Muttern	nuts	M 3 DIN 934 ³¹⁴	M 3 DIN 934 ³¹⁴	4 pieces
45	8	Federscheiben	spring washers	B 3 DIN 127 ³¹⁴	B 3 DIN 127 ³¹⁴	4 pieces
46	1	Erdschraube	ground screw	M 4 × 5 DIN 84 ⁴³³	M 4 × 5 DIN 84 ⁴³³	M 4 × 5 DIN 84 ⁴³³
47	1	Schild (Pilotlicht)	plate (pilot light)	IBSQ 1/2 X	IBSQ 1/2 X	IBSQ 1/2 X
48	1	Schild (Spiegellampe)	plate (arc lamp)	IBSQ 1/7 X	IBSQ 1/7 X	IBSQ 1/7 X
49	1	Schild (Gefahr)	plate (emergency)	IBSQ 1/8 X	IBSQ 1/8 X	—

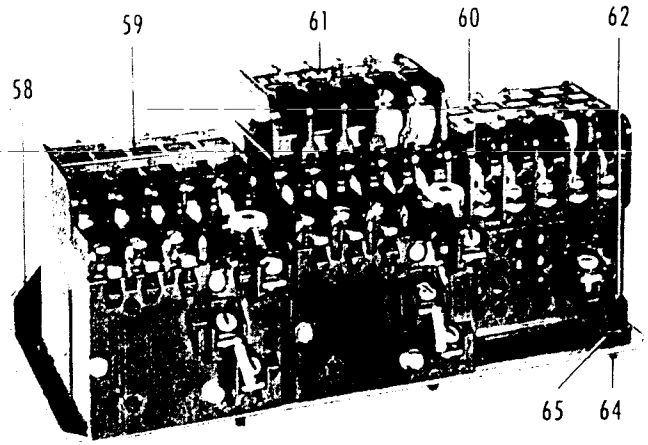
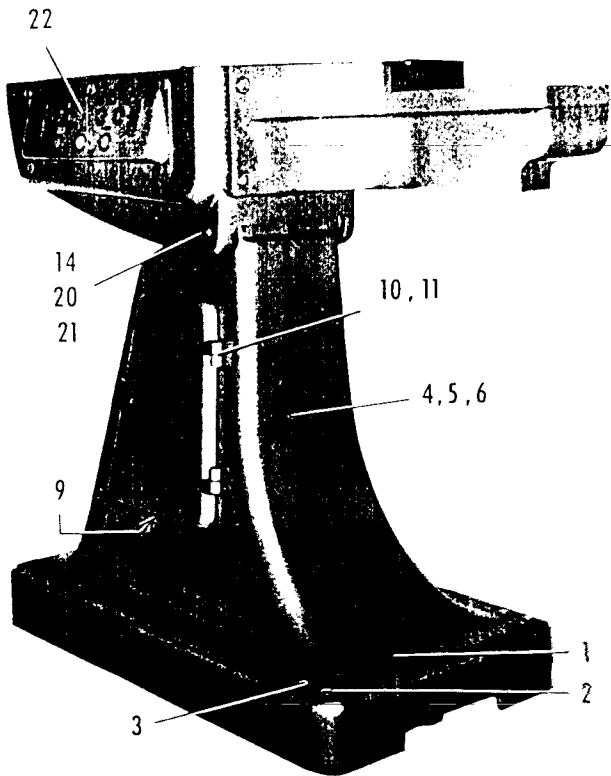

380/220 V, 50 Hz

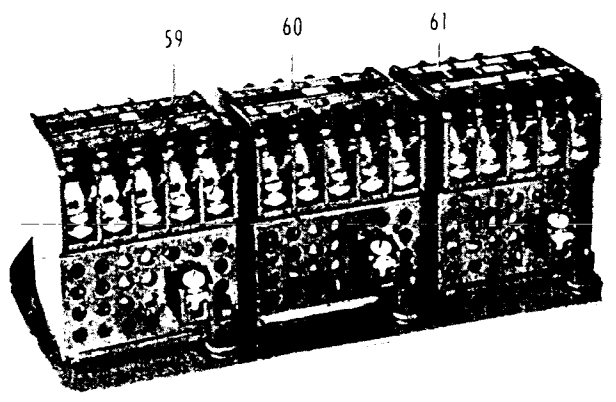

115 V, 60 Hz

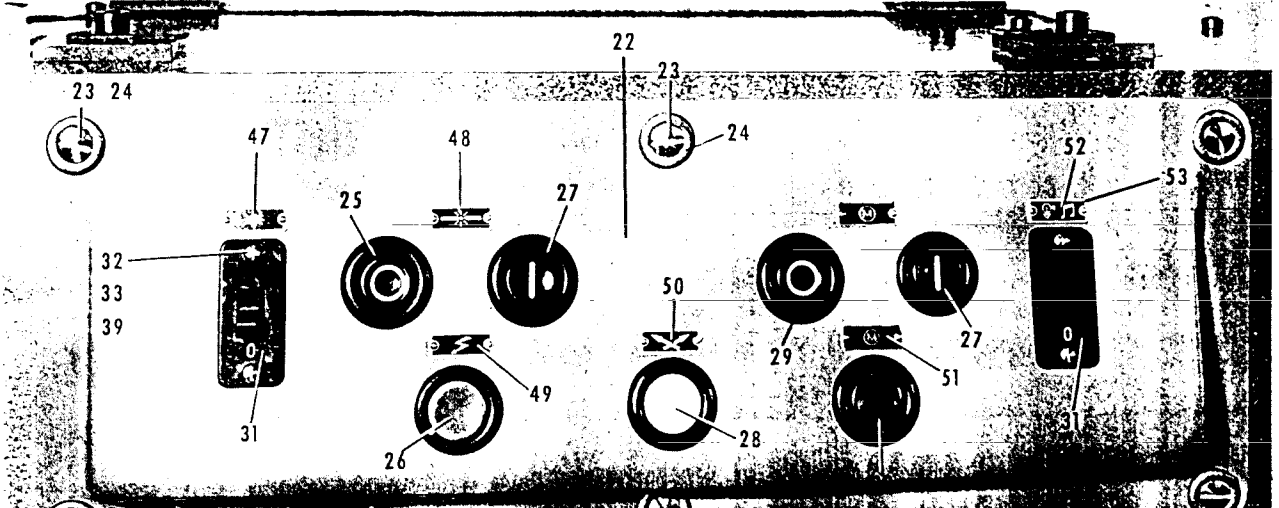
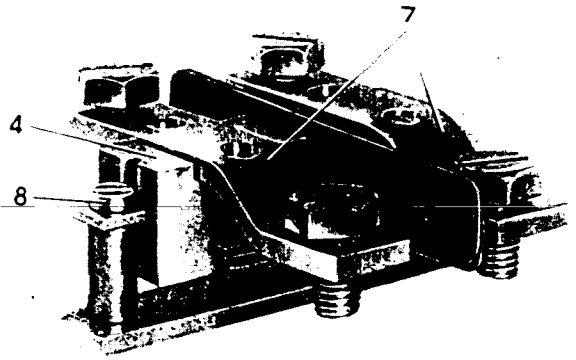
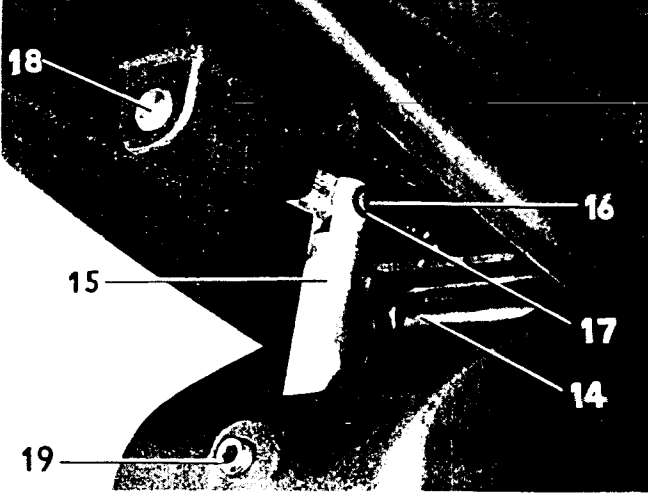

Lfd. Nr.	Stückzahl	ERSATZTEIL-LISTE	SPARE PART LIST	Drehstrom		115 V 60 Hz
				380 V 50 Hz	220 V 50 Hz	
No.	qt.	Säule mit Tischplatte	Pedestal with table plate			
50	1	Schild (Überblendung)	plate (change-over)	IBSQ 1/10 X	IBSQ 1/10 X	—
51	2	Schilder (Motor)	plates (motor)	IBSQ 1/9 X	IBSQ 1/9 X	IBSQ 1/9 X
52	1	Schild (Tonlampe)	plate (exciter lamp)	IBSQ 1/1 X	IBSQ 1/1 X	—
53	14	Kerbnägel	grooved pins	1,4 x 2,5 DIN 1476	1,4 x 2,5 DIN 1476	6 pieces
54	1	Zeitrelais	time-delay relay	—	—	UF 2 SH 3/1 Z
55	1	Widerstand	resistance	—	—	W—1 B 473 E 1
56	2	Schrauben	screws	—	—	M 4 x 36 DIN 91 ⁸²³
57	2	Muttern	nuts	—	—	M 4 DIN 934 ⁸²³
58	1	Schalterschütz winkel* komplett	elbow for contactor complete	BF 14 MF 8/5 Z	BF 14 MF 8/6 Z	BF 14 MF 8/2 Z
59	1	Schalterschütz A, 4—8 A	contactor	IBSH 9/2 Y	IBSH 9/2 Y	UF 2 SH 2/1 Z [C]
60	1	Schalterschütz LH	contactor	BF 14 SH 3 2 Y	BF 14 SH 3 2 Y	UF 2 SH 2/1 Z [A]
61	1	Schalterschütz C, 0,5—1 A	contactor	BF 14 SH 9/2 Z	BF 14 SH 9/3 Z	UF 2 SH 2/1 Z [B]
62	9	Schrauben	screws	M 4 x 25 DIN 84 ³¹⁴	M 4 x 25 DIN 84 ³¹⁴	M 4 x 25 DIN 84 ³¹⁴
64	9	Muttern	nuts	M 4 DIN 934 ³¹⁴	M 4 DIN 934 ³¹⁴	M 4 DIN 934 ³¹⁴
65	9	Gummitüllen	rubber sleeves	NB 52/1 X	NB 52/1 X	NB 52/1 X
66	1	Trafowinkel komplett*	elbow for transformer	UF 2 MF 13/1 Z	UF 2 MF 13/2 Z	BF 14 MF 9/2 Z
67	1	Trafo, 6 V für Tönl.	transformer	TR 56/1 Y	TR 56/1 Y	TR 56/1 Y
68	1	Gleichrichter mit Trafo	rectifier	BW 14 TR 1/1 Z	BW 14 TR 1/1 Z	BW 14 TR 1/2 Z
69	8	Schrauben	screws	M 4 x 10 DIN 84 ³¹⁴	M 4 x 10 DIN 84 ³¹⁴	M 4 x 10 DIN 84 ³¹⁴
70	8	Federscheiben	spring washers	B 4 DIN 127 ³¹⁴	B 4 DIN 127 ³¹⁴	B 4 DIN 127 ³¹⁴
71	8	Muttern	nuts	M 4 DIN 934 ³¹⁴	M 4 DIN 934 ³¹⁴	M 4 DIN 934 ³¹⁴
72	1	Widerstand (Kusa)	resistance	IBWI 1/1 Z	IBWI 1/4 Z	IBWI 1/3 Z
73	2	Splinte	split pins	4 x 20 DIN 94 ³¹⁴	4 x 20 DIN 94 ³¹⁴	4 x 20 DIN 94 ³¹⁴
74	2	Kleinschütze B u. D	small contactors	BF 14 SH 10/1 Z	BF 14 SH 10/1 Z	—
75	1	Kleinschütz H	small contactor	—	—	UF 2 SH 1/1 Z
76	4	Schrauben	screws	M 3 x 20 DIN 84 ³¹⁴	M 3 x 20 DIN 84 ³¹⁴	2 pieces
77	4	Muttern	nuts	M 3 DIN 934 ³¹⁴	M 3 DIN 934 ³¹⁴	2 pieces
78	4	Gummitüllen	rubber sleeves	NB 51/1 X	NB 51/1 X	2 pieces
79	2	Federscheiben	spring washers	—	—	B 3 DIN 127
80	1	Widerstandsträger	holder for resistance	BF 14 MF 17/2 Z	BF 14 MF 17/1 Z	—
81	4	Federscheiben	spring washers	B 4 DIN 127 ³¹⁴	B 4 DIN 127 ³¹⁴	—
82	6	Muttern	nuts	M 4 DIN 934 ³¹⁴	M 4 DIN 934 ³¹⁴	—
83	2	Widerstände V_1-V_2 30 Ω V_2-V_3 30 Ω	resistances	UF 2 WI 1/3 Z	UF 2 WI 1/1 Z (12 Ω)	—
84	1	Widerstand U_1-U_2 50 Ω	resistance	UF 2 WI 1/4 Z	UF 2 WI 1/2 Z (20 Ω)	—
85	1	Klemmleiste	terminal block	WN 31 EA 1/6 Z	WN 31 EA 1/6 Z	—
86	2	Schrauben	screws	M 3 x 18 DIN 84 ³¹⁴	M 3 x 18 DIN 84 ³¹⁴	—
87	2	Muttern	nuts	M 3 DIN 934 ³¹⁴	M 3 DIN 934 ³¹⁴	—
88	2	Scheiben	washers	B 3 DIN 127 ³¹⁴	B 3 DIN 127 ³¹⁴	—
89	1	Zeitrelaissträger*	holder for time-delay relay	UF 2 MF 11/1 Z	UF 2 MF 11/1 Z	—
90	2	Schrauben	screws	M 5 x 15 DIN 85	M 5 x 15 DIN 85	M 5 x 15 DIN 85
91	1	Zeitrelais	time-delay relay	UF 2 SH 3/1 Y	UF 2 SH 3/1 Y	—
92	2	Schrauben	screws	M 4 x 38 DIN 85 ⁸²³	M 4 x 38 DIN 85 ⁸²³	—
93	2	Muttern	nuts	M 4 DIN 934 ⁸²³	M 4 DIN 934 ⁸²³	—
94	1	Anschlußleiste	connection panel	UF 2 AL 1/1 Z	UF 2 AL 1/1 Z	UF 2 AL 1/1 Z
95	1	Anschlußleiste	connection panel	UF 2 AL 1/3 Z	UF 2 AL 1/3 Z	—
96	50	Aufreihklemmen	terminal blocks	UF 2 EA 1/1 Z	UF 2 EA 1/1 Z	32 pieces
97	4	Distanzbolzen	distance pins	UF 2 BO 3/1 X	UF 2 BO 3/1 X	2 pieces
98	4	Endwinkel	stops	UF 2 BE 3/1 X	UF 2 BE 3/1 X	2 pieces
99	5	Schrauben	screws	M 4 x 8 DIN 85 ⁸²³	M 4 x 8 DIN 85 ⁸²³	2 pieces
100	4	Schrauben (Bef.-Leiste)	screws	M 5 x 18 DIN 85 ⁸²³	M 5 x 18 DIN 85 ⁸²³	2 pieces
101	1	Kondensator 40 μ F	condenser 40 μ F	—	—	K-B Ko MP 60 40 D 220 34
102	1	Kondensator 100 μ F	condenser 100 μ F	—	—	K-B Ko MP 73 100 K 240 A 35
103	1	Halter f. Kond.	holder for cond.	—	—	UF 2 BE 4/1 Z
104	2	Zylinderschrauben	cylindrical screws	—	—	M 5 x 20 DIN 84 ³¹⁴
105	2	Muttern	nuts	—	—	M 5 DIN 934 ³¹⁴
106	2	Scheiben	washers	—	—	5,3 DIN 125 ³¹⁴
107	1	Kabelsatz	set of cables	UF 2 KA 4/2 Z	UF 2 KA 4/2 Z	UF 2 KA 3/1 Z
		Schaltplan	diagram	SS 683a	SS 683a	SS 653a
		Stromlaufplan	schematic wiring diagram	SS 683b	SS 683b	SS 653b

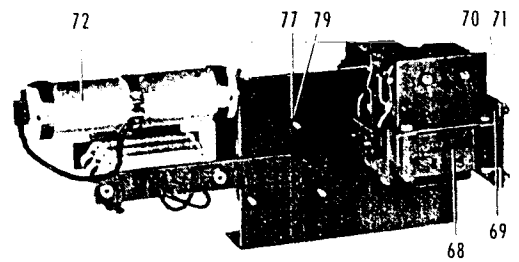
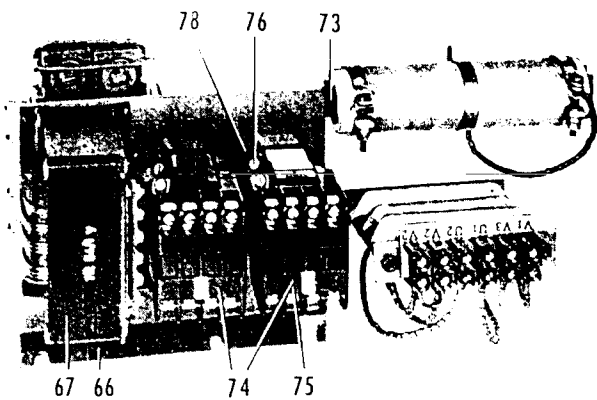
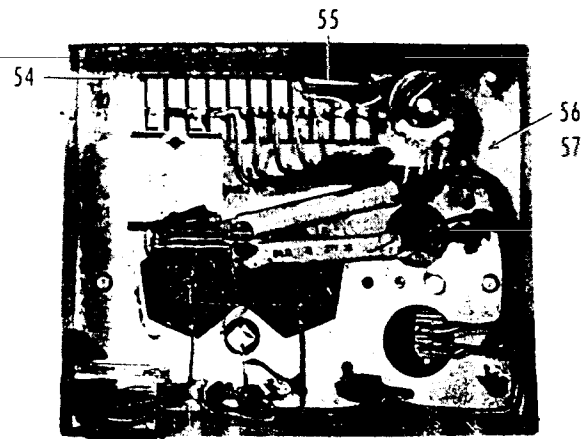
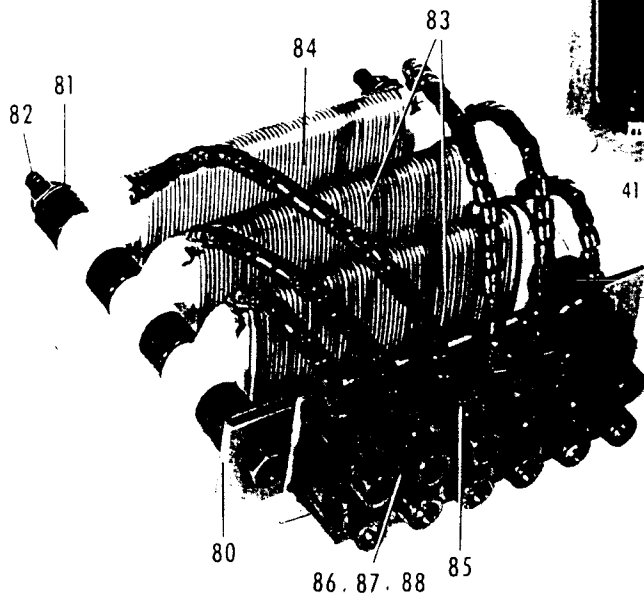
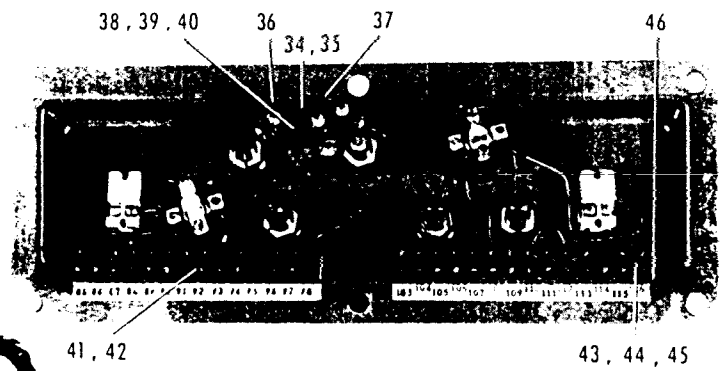
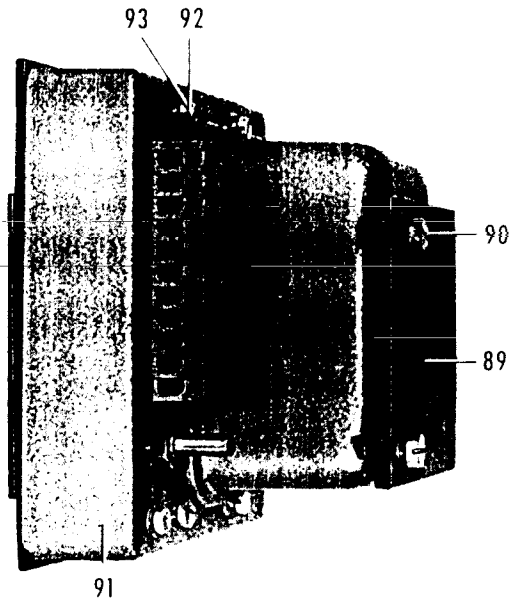
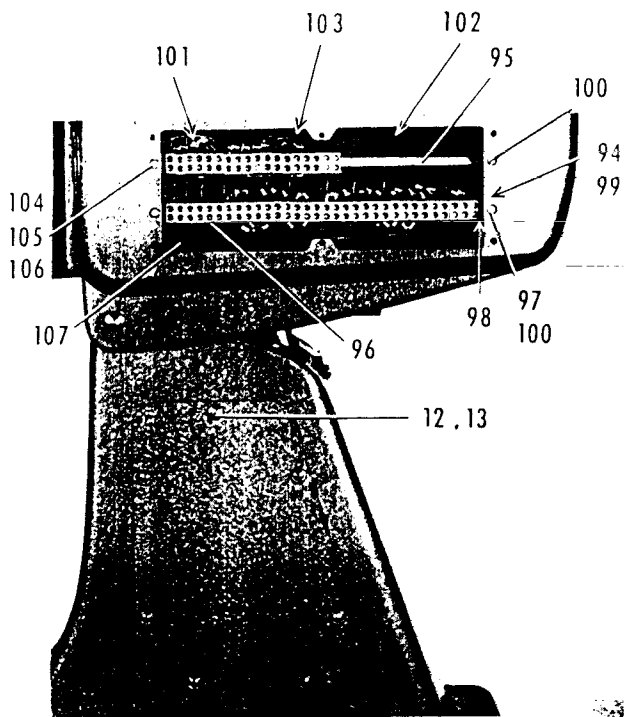

Lfd. Nr.	Stückzahl	ERSATZTEIL-LISTE		SPARE PART LIST		Drehstrom 50 Hz.		Single phase 115 V, 60 Hz.
		No.	qt.	Motor für Werkantrieb	Motor for projector drive	127/220 V	220/380 V	
1	1		Synchronmotor kompl.*	synchronous motor, complete	UM 2 D 1 S 1 R 1	UM 2 D 2 S 1 R 1	UM 2 W 1 S 1 R 1	
2	1		Motor allein	motor alone	UM 2 MO 3/1 Y	UM 2 MO 2/1 Y	UM 2 MO 1/1 Y	
3	1		Schutzdeckel f. Anschluß	cover for connection	UM 2 DE 2/1 X	UM 2 DE 2/1 X	UM 2 DE 2/1 X	
4	1		Anschlußbrett	connection board	MCEA 2/1 Z	MCEA 2/1 Z	MCEA 2/1 Z	
5	2		Kugellager	ball bearings	KL 4/1 Z	KL 4/1 Z	KL 4/1 Z	
6	1		Bolzen	pin	UM 2 BO 3/1 X	UM 2 BO 3/1 X	UM 2 BO 3/1 X	
7	1		Kugelgriff	knob	HG 49/1 X	HG 49/1 X	HG 49/1 X	
8	1		Gewindestift L. Motor-Anschlag	threaded pin for left motor	UM 2 SR 1/1 X	UM 2 SR 1/1 X	UM 2 SR 1/1 X	
9	1		Gewindestift R. Motor-Anschlag	threaded pin for right shoulder	M 8 x 25 DIN 913	M 8 x 25 DIN 913	M 8 x 25 DIN 913	
10	2		Zahnscheiben	toothed washers	J 8,4 DIN 6797	J 8,4 DIN 6797	J 8,4 DIN 6797	
11	2		Muttern	nuts	M 8 DIN 439	M 8 DIN 439	M 8 DIN 439	
12	1		Griffbolzen	grip pin	UM 2 BO 1/1 X	UM 2 BO 1/1 X	UM 2 BO 1/1 X	
13	1		Scheibe Schwenk-Lager	washer swinging support	MS 45/8 X	MS 45/8 X	MS 45/8 X	
14	1		Bolzen	pin	UM 2 BO 2/1 X	UM 2 BO 2/1 X	UM 2 BO 2/1 X	
15	1		Kugelgriff	knob	HG 29/1 X	HG 29/1 X	HG 29/1 X	
16	1		Lüftergehäuse	housing for fan	UW 2 GE 3/1 X	UW 2 GE 3/1 X	UW 2 GE 3/1 X	
17	2		Sicherungsringe	locking rings	MBMR 15/1 X	MBMR 15/1 X	MBMR 15/1 X	
18	2		Haltröhrchen	little fastening tubes	MBRR 14/1 X	MBRR 14/1 X	MBRR 14/1 X	
19	1		Führungsrohr unten	guide tube, below	UW 2 RR 1/1 X	UW 2 RR 1/1 X	UW 2 RR 1/1 X	
20	1		I. Sechskantschraube für Rohr	hexagon socket screw for tube	M 10 x 15 DIN 912 ^{***}	M 10 x 15 DIN 912 ^{***}	M 10 x 15 DIN 912 ^{***}	
21	2		Seeger-Sicherungsringe	spring clips	32 x 1,5 DIN 471	32 x 1,5 DIN 471	32 x 1,5 DIN 471	
22	1		Führungsbolzen oben	guide pin	UW 2 BO 6/1 X	UW 2 BO 6/1 X	UW 2 BO 6/1 X	
23	1		I. Sechskantschraube für Bolzen	hexagon socket screw for pin	M 8 x 25 DIN 912 ^{***}	M 8 x 25 DIN 912 ^{***}	M 8 x 25 DIN 912 ^{***}	
24	2		I. Sechskantschrauben für Lüftergehäuse	hexagon socket screws for fan housing	M 12 x 30 DIN 912 ^{***}	M 12 x 30 DIN 912 ^{***}	M 12 x 30 DIN 912 ^{***}	
25	1		Kupplungsscheibe	coupling disc	UW 2 KP 1/2 Z	UW 2 KP 1/2 Z	UW 2 KP 1/2 Z	
26	1		Gummikupplung	rubber coupling	NF 4/2 X	NF 4/2 X	NF 4/2 X	
27	2		Scheibefedern	Woodruff keys	KE 1/1 X	KE 1/1 X	KE 1/1 X	
28	2		Unterlegscheiben für Zahnräder	washers for gears	UW 2 MS 1/1 Z	UW 2 MS 1/1 Z	UW 2 MS 1/1 Z	
29	2		Senkschrauben für Stirnseitig	flat head screws face-side	M 5 x 12 DIN 87	M 5 x 12 DIN 87	M 5 x 12 DIN 87	
30	1		Abdeckring	cover ring	UW 2 MR 3/1 Z	UW 2 MR 3/1 Z	UW 2 MR 3/1 Z	
31	4		Federn dazu	springs for above	UW 2 FS 1/1 X	UW 2 FS 1/1 X	UW 2 FS 1/1 X	
32	1		Zahnrad komplett mit Lüfter (alte Ausf.)	gear complete with fan	UW 2 ZR 3/1 Z	UW 2 ZR 3/1 Z	UW 2 ZR 5/1 Z	
32a	1		Zahnrad kompl. mit Lüfter (neue Ausf.)	gear complete with fan	UW 2 ZR 40/1 Z	UW 2 ZR 40/1 Z	—	
33	1		Innenzahnrad Einzelteil (alte Ausf.)	inner gear, single part	UW 2 ZR 3/1 X	UW 2 ZR 3/1 X	UW 2 ZR 5/1 X	
33a	1		Doppel-Außenzahnrad, Resitex, Einzelteil (neue Ausführung)	double outergear, Resitex single part	UW 2 ZR 40/1 Y	UW 2 ZR 40/1 Y	—	
34	1		Außenzahnrad Resitex	outer gear, Resitex	UW 2 ZR 7/1 X	UW 2 ZR 7/1 X	—	
35	4		Senkschrauben	flat head screws	M 5 x 30 DIN 63	M 5 x 30 DIN 63	—	
36	1		Lüfter	ventilator fan	UW 2 LS 1/1 X	UW 2 LS 1/1 X	UW 2 LS 1/1 X	
37	2		Zylinderstift	cylindrical pins	3 x 14 DIN 7	3 x 14 DIN 7	3 x 18 DIN 7	
38	4		Senkschrauben	flat head screws	M 5 x 12 DIN 63	M 5 x 12 DIN 63	M 5 x 15 DIN 63	
39	1		Zahnrad komplett auf Motorseite (alte Ausf.)	gear, complete on motor side	UW 2 ZR 4/1 Z	UW 2 ZR 4/1 Z	UW 2 ZR 6/1 Z	
39a	1		Innenzahnrad kompl. auf Motorseite, mit Schmiernippel (neue Ausführung)	inner gear complete on motor side	UW 2 ZR 4/3 Z	UW 2 ZR 4/3 Z	—	
40	1		Außenzahnrad Einzelteil	outer gear, single part	—	—	UW 2 ZR 6/1 X	

Lfd. Nr.	Stückzahl	ERSATZTEIL-LISTE	SPARE PART LIST	Drehstrom 50 Hz.		Single phase 115 V, 60 Hz.
				127/220 V	220/380 V	
No.	qt.	Motor für Werkantrieb	Motor for projector drive			
41	1	Außenzahnkranz Resitex	outer gear ring, Resitex	—	—	UW 2 ZR 8/1 X
42	1	Zahnrad innen und außen (alte Ausf.)	gear, inner and outer one	UW 2 ZR 4/1 X	UW 2 ZR 4/1 X	—
43	2	Zylinderstifte	cylindrical pins	—	—	3×24 DIN 7
44	4	Senkschrauben	flat head screws	—	—	M 4×25 DIN 63-
45	2	Mitnehmerbolzen für Gummikupplung	driving pins for rubber coupling	BO 57/1 X	BO 57/1 X	BO 57/1 X
46	1	Schmiernippel an Pos. 39a	lubricating nipple on Pos. 39	UW 2 MB 27/1 X	UW 2 MB 27/1 X	—
47	1	Druck-Schmierkopf in Pos. 46	pressure lubricator in Pos. 46	UW 2 AM 2/1 Z	UW 2 AM 2/1 Z	—
48	2	Zylinderstifte	cylindrical pins	3×12 DIN 7	3×12 DIN 7	—

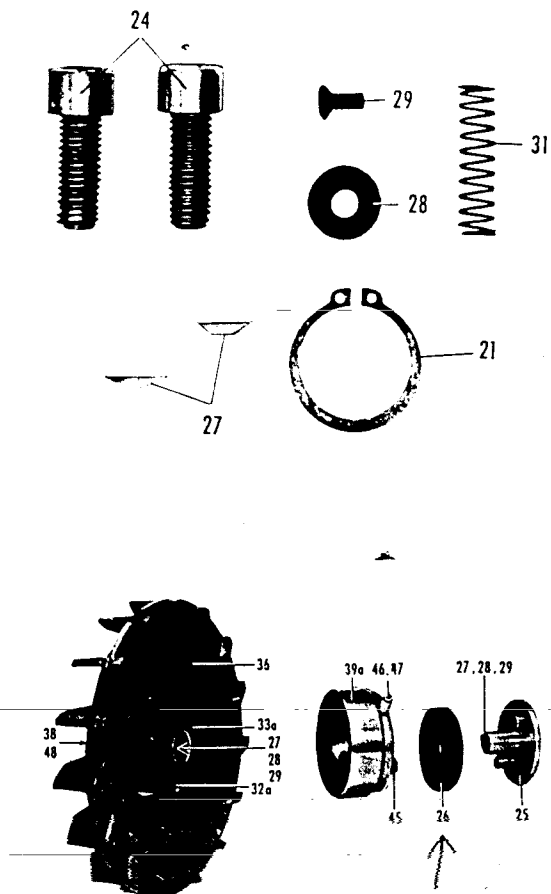
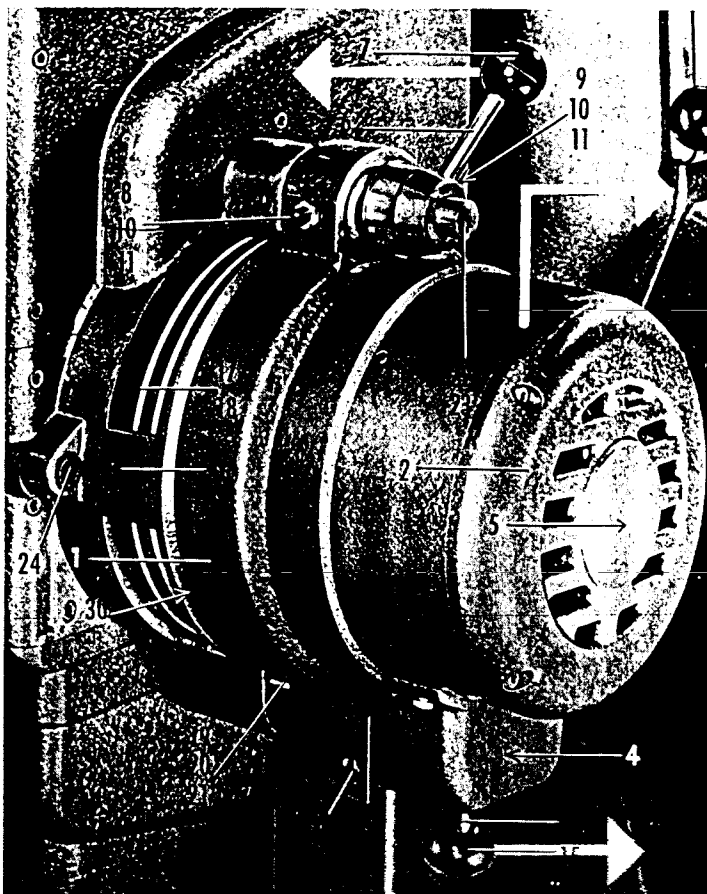

Pos. 32 Deutsche Ausführung

Pos. 39 Deutsche Ausführung

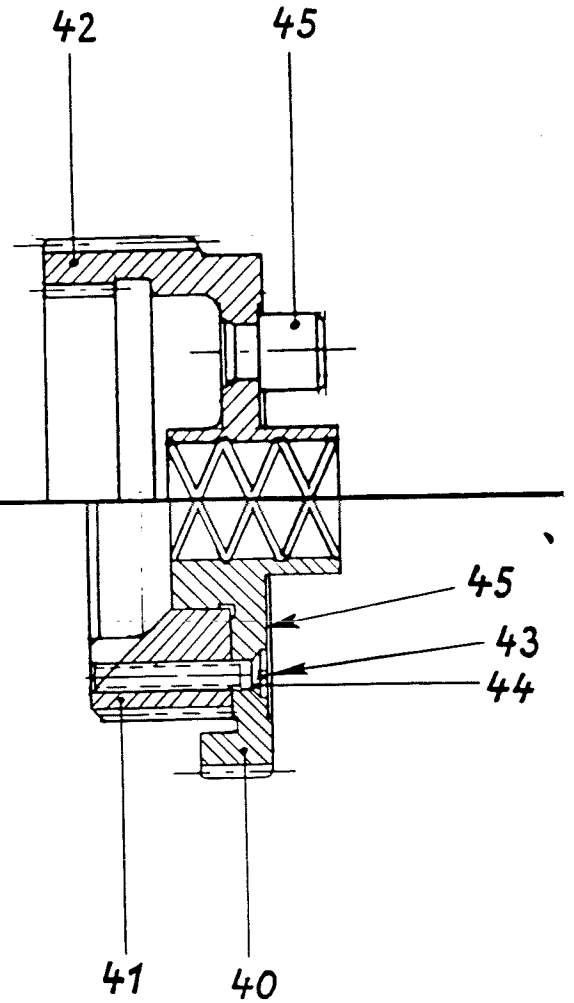
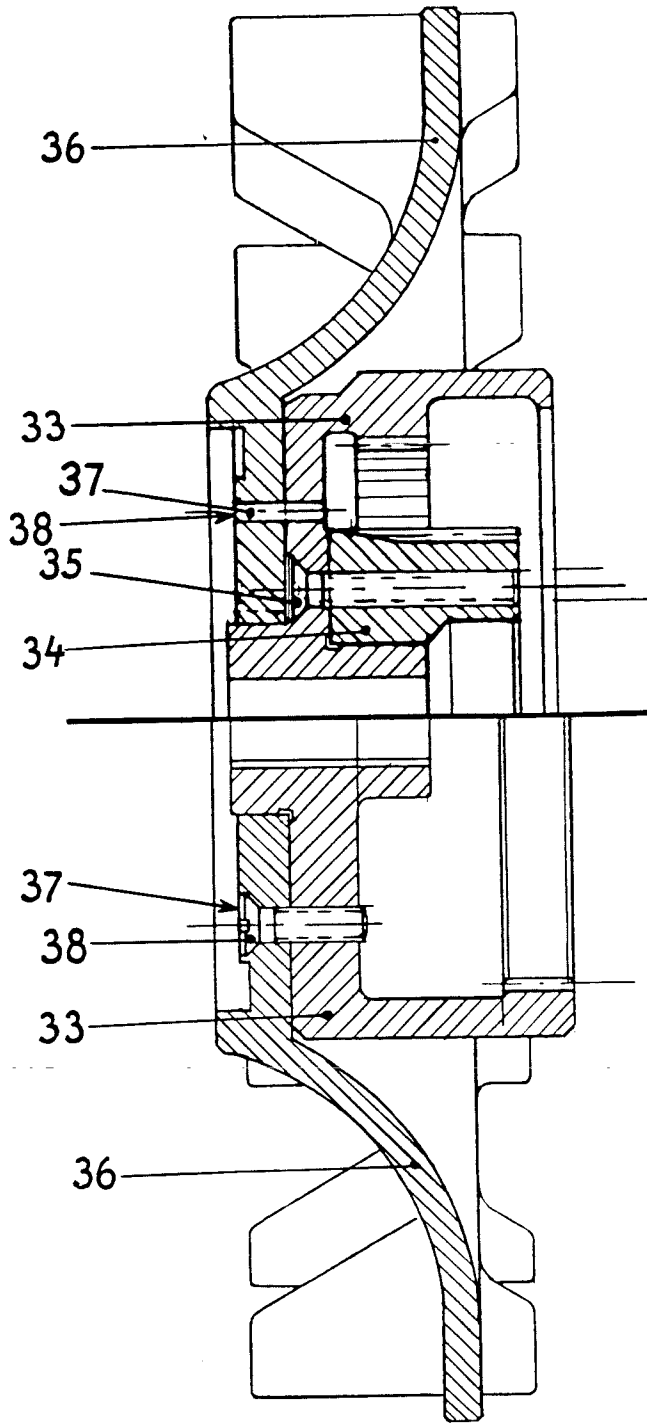

Pos. 32 Amerikanische Ausführung

Pos. 39 Amerikanische Ausführung

Bei Motoren mit der Typenbezeichnung **UM 2 D 2 A 1 R 1** entfallen bei der Standardausführung für 220 V 3 ~ und 380 V 3 ~ 50 Hz (Asyn. 300 W) folgende Teile:

Seite 28 Pos. 58 Schaltschützwinkel kompl.
 best. aus: Pos. 59, 60, 61, 62
 64, 65
 dafür kommt neu hinzu:
 1 Schaltschützwinkel kompl. BF 14 MF 8/8 Z
 best. aus:
 1 Schaltschützwinkel BF 14 MF 8/1 X
 1 Schaltschütz (A) UF 2 SH 2/3 Z
 1 Bi-Metallrelais (an Schaltschütz A) 1,1 A (380 V);
 1,6 A (220 V) JBSH 12/1 Y
 1 Schaltschütz (LH) BF 14 SH 3/2 Y
 9 Zylinderschrauben M 4 x 25 DIN 84³¹⁴
 9 Muttern M 4 DIN 934
 9 Gummitüllen NB 52/1 X
 1 Schaltschütz (C) mit Stromwächter, 0,65 A (380 V);
 1,15 A (220 V) BF 14 SH 9/2 Z

Bei Motoren mit der Typenbezeichnung **UM 2 D 2 A 1 R 2** entfallen bei der Standardausführung für 220 V 3 ~ und 380 V 3 ~ 50 Hz (Asyn. 250 W) folgende Teile:

Seite 30 Pos. 39a, 25, 26
 dafür kommt neu hinzu:
 1 Innenzahnrad UW 2 Z R 4/2 X
 weiterhin entfallen:
 Seite 28 Pos. 58 bis 93 und Pos. 107
 dafür kommen neu hinzu:
 1 Schaltschützwinkel kompl. BF 14 MF 18/4 Z
 bestehend aus:
 1 Schaltschützwinkel BF 14 MF 18/1 X
 1 Schaltschütz UF 2 SH 2/3 Z
 1 Stromwächter 1—2 A JBSH 12/1 Y
 3 Gummitüllen NB 52/1 X
 3 Zylinderschrauben M 4 x 25 DIN 84³¹⁴
 3 Sechskantmutter M 4 DIN 934³¹⁴
 1 Trafowinkel kompl. BF 14 MF 19/5 u. 6 Z
 bestehend aus:
 1 Trafowinkel BF 14 MF 9/1 Y
 1 Trafo, 6 V für Tonlampe TR 56/1 Y
 1 Gleichrichter mit Trafo BW 14 TR 1/1 Z
 8 Schrauben M 4 x 10 DIN 84³¹⁴
 8 Muttern M 4 DIN 934³¹⁴
 8 Federringe B 4 DIN 127³¹⁴
 1 Widerstand für 220 V JBWJ 1/7 Z
 1 Widerstand für 380 V JBWJ 1/6 Z
 1 Splint 4 x 20 DIN 94³¹⁴
 1 Bi-Metall-Schalter BF 11 SH 2/1 Z
 1 Zylinderschraube M 4 x 28 DIN 84³¹⁴
 1 Sechskantmutter M 4 DIN 934³¹⁴
 1 Kabelsatz UF 2 KA 6/1 Z
 1 Schaltplan SS 757a
 1 Stromlaufplan SS 757b

Lfd. Nr.	Stückzahl	ERSATZTEIL-LISTE	SPARE PART LIST	Standard-Ausführung	U.S.A.-Type
No.	qt.	Kühlgebläse	Air blower		
1	1	Kühlgebläse komplett	Air blower, compl.	BG 3 D 2 A 1	BG 3 W 1 A 2
2	1	Motor 220/380 V 50 Hz ≈	motor	BM 11 M0 7/1 Z	—
2	1	Motor 115 V 60 Hz ~	motor	—	BM 11 M0 5/2 Z
3	1	Kondensator 50 μF	condenser ≈ 69 mm	—	K-Bi/Ko/MP69/50D220A35
4	1	Befestigungs-Schelle für Kondens.	fastening clip	—	UF 2 BE 7/1 Z
oder 2	1	Motor 115 V 60 Hz ~	motor	—	BM 11 M0 5/4 Z
3	1	Kondensator 30 μF	condenser ≈ 55 mm	—	K-Bi/Ko/MP55/30D 220/56
4	1	Befestigungs-Schelle für Kondens.	fastening clip	—	UF 2 BE 7/2 Z
5	4	Befestigungsschrauben	fastening screws	M 5 × 12 DIN 912 ^{***}	M 5 × 12 DIN 912 ^{***}
6	1	Scheibe	washer	BG 3 MS 1/1 X	BG 3 MS 1/1 X
7	1	Schraube	screw	M 5 × 12 DIN 933 ⁻	M 5 × 12 DIN 933 ⁻
8	1	Federring	spring ring	B 5 DIN 127 ⁻	B 5 DIN 127 ⁻
9	7	Schrauben für Gebläsedeckel	screws for blower cover	M 5 × 18 DIN 912 ^{***}	M 5 × 18 DIN 912 ^{***}
10	1	Scheibe	washer	MS 45/8 X	MS 45/8 X
11		Scheiben nach Bedarf	washers (as required)	MS 45/1 . . 5 X	MS 45/1 . . 5 X
12	2	Scheibenfedern	Woodruff keys	KE 1/1 X	KE 1/1 X
13	8	Lamellen	laminas	KG 216/1 X	KG 216/1 X
14	1	Motorkappe	motor cap	BM 11 DE 1/1 X	BM 11 DE 1/1 X
15	2	Schrauben für Pos. 12 u. 24	screws	M 4 × 8 DIN 86 ^{***}	M 4 × 10 DIN 86 ^{***}
16	1	Staufferbüchse	Stauffer lubricator	BG 3 MB 1/1 Z	BG 3 MB 1/1 Z
17	2	Luftfilter	air filters	BG 3 GE 1/1 Z	BG 3 GE 1/1 Z
18	1	Schlauchnippel	hose nipple	BG 3 RV 2/1 X	—
19	1	Saugnippel	suction nipple	BG 3 RV 1/1 X	—
18	1	Saugnippel	suction nipple	—	BG 3 RV 1/1 X
19	1	Schlauchnippel	hose nipple	—	BG 3 RV 2/1 X
20	1	Luftschlauch 3/4"	air hose	GBRR 1/80 X	GBRR 1/80 X
21	2	Schlauchklemmen	hose clips	BE 1/1 Z	BE 1/1 Z
22	1	Schlauchverschraubung	screw type	GBRV 4/1 Z	GBRV 4/1 Z
			hose coupling		
23	1	Schlauchnippel	hose nipple	BL 10 RV 6/1 X	—
24	1	Luftschlauch 1/2"	air hose	BW 14 RR 5/180 X	—
25	2	Schaumstoff-Filter	filter of plastic material	BG 3 NS 1/1 X	BG 3 NS 1/1 X
26	4	Drahtsiebe	wire screens	BG 3 MF 2/1 X	BG 3 MF 2/1 X
27	2	Filterkappen	filter caps	BG 3 GE 2/1 X	BG 3 GE 2/1 X
28	2	Schrauben	screws	BG 3 SR 1/1 X	BG 3 SR 1/1 X
29	2	Sicherungsscheiben	lock washers	6 DIN 6799	6 DIN 6799
30	1	Dose Spezialfett	can of special grease	ZU 173/8 Z	ZU 173/8 Z

Kühlgebläse für U 2-Projektor

Die Schmierung des Kühlgebläses mit Hilfe der Schmierbüchse ist in der Bedienungsanleitung des U 2-Projektors beschrieben. In monatlichen Abständen empfiehlt es sich, das überschüssige Fett wieder aus dem Kühlgebläse zu entfernen. Dies wird am einfachsten mit einer Durchspülung des Kühlgebläses erreicht. Auf nebenstehendem Bild sehen Sie, daß der Druckstutzen des Kühlgebläses vollständig abgenommen wurde und vom Ansaugstutzen das Oberteil entleert ist. In das Gewinde für den Druckstutzen wird das Gewindestück des Spülschlauches eingeschraubt. Die Düse am anderen Ende des Spülschlauches wird, wie auf dem Bild ersichtlich, mit einer Schraube in dem Unterteil des Ansaugstutzens gehalten. Nun gießt man in den Ansaugstutzen des laufenden Kühlgebläses etwa 1/4 l Petroleum, welches einen Kreislauf macht und dabei alle fest gewordenen Fettreste löst. Nach einer Laufzeit von 5—10 Minuten läßt man durch den Spülschlauch das Petroleum wieder auslaufen und preßt vor der Inbetriebnahme des Gebläses 1—2 ganze Fettfüllungen durch die Schmierbüchse langsam in das laufende Gebläse.

Bestell-Nr. des Spülschlauches BG 3 ZU 1/1 Z.
Siehe Seite 35 Bild oben links.

Air Blower of U 2 Projector

The way of lubricating the air blower with the grease cup is described in the instruction manual of the U 2 projector. It is advisable to take the surplus grease out of the blower, monthly. This is easily achieved by flushing the blower. The complete pressure joint of the air blower and the upper part of the input socket-piece are to be removed as to be seen on page 35. (In the USA type the pressure joint and grease cup are on the right side while the input socket piece is on the left side of the air blower.)

The threaded flange of the flushing hose is then screwed into the thread of the pressure joint. The nozzle on the other end of the hose is fixed by a screw in the base of the input socket-piece.

1/4 l of kerosene is now poured into the input socket to run through the machine until every trace of grease has been washed out of the interior.

After a running time of 5—10 minutes, the kerosene must be let off through the hose.

Before setting the blower into operation again, 1—2 completely filled grease cups should be pressed slowly into the running blower (by turning the cup.).

Designation No of the hose: BG 3 ZU 1/1 Z.

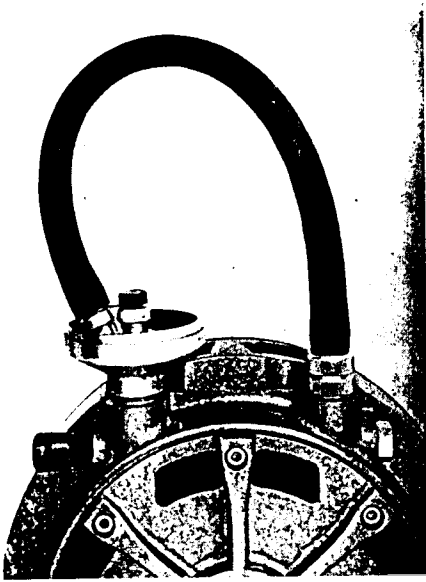

Anordnung zur Spülung des Kühlgebläses bei der Standardausführung

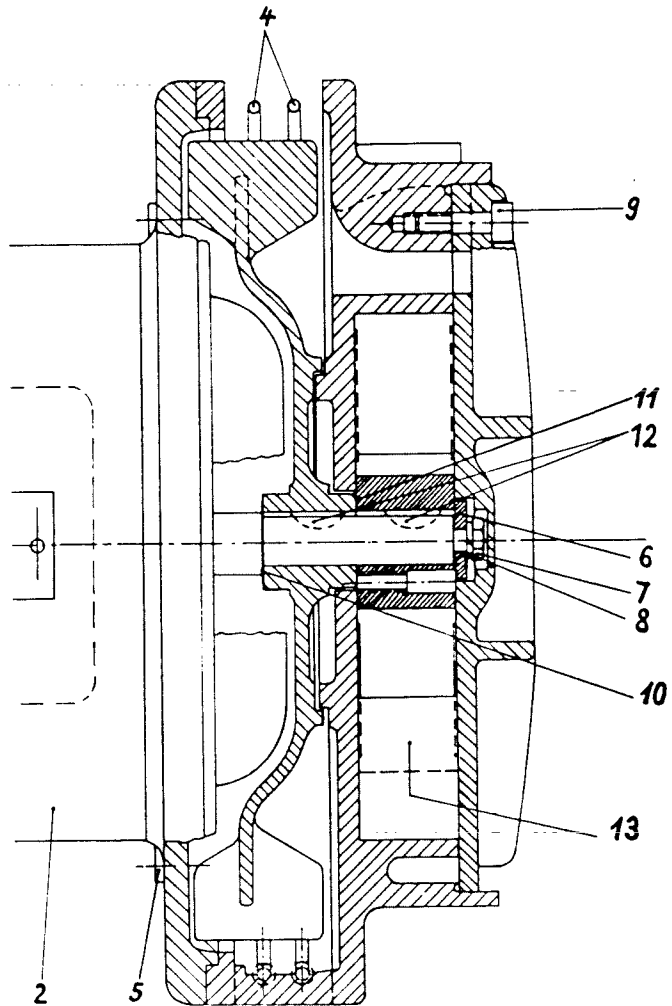
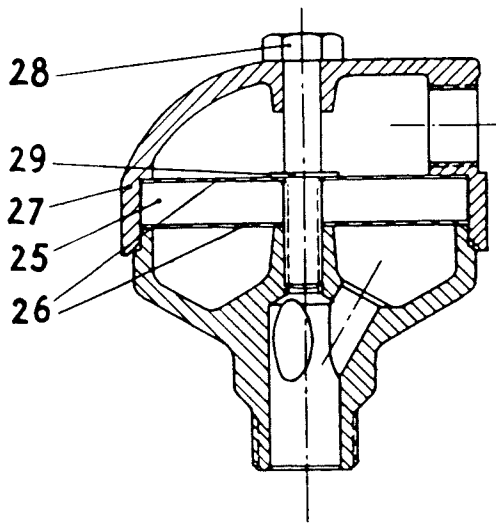
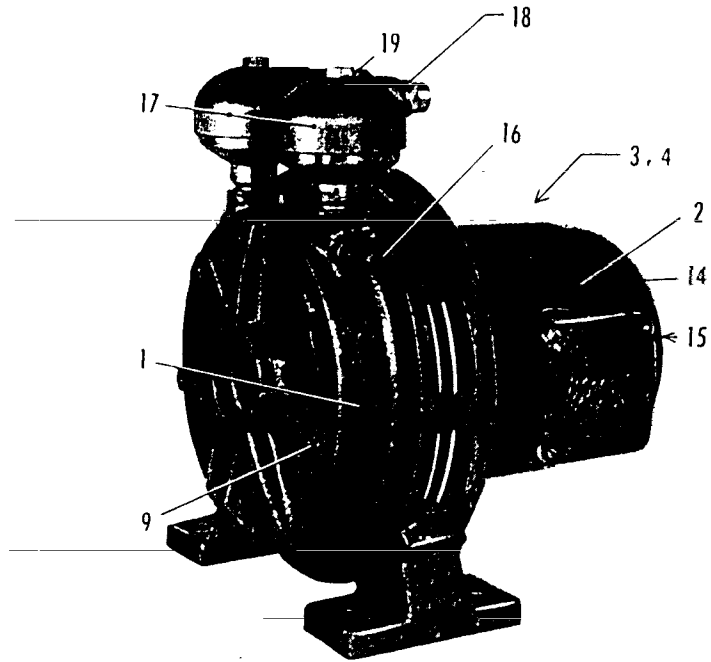

Lfd. Nr.	Stückzahl	ERSATZTEIL-LISTE	SPARE PART LIST	Bestell-Nr.
No.	qt.	Werkzeugsatz	Tool kit	Order No.
1	1	Werkzeugsatz komplett bestehend aus:	Tool kit complete comprising:	UZ 101 WE 2/1 Z
2	1	Palette	kit	MBZU 2/1 Y
3	1	Trichter	funnel	MAZU 1/1 Z
4	1	Ölkanne	oil can	MAZU 6/1 Z
5	1	Kufenschaber	scraper	MAZU 7/1 Z
6	1	Schraubenzieher, klein	screw driver, small	MAZU 18/1 Z
7	1	Schraubenzieher, mittel	screw driver, medium size	MAZU 19/1 Z
8	1	Schraubenzieher, groß	screw driver, large size	MAZU 20/1 Z
9	1	Gabelschlüssel 10×14	hexagon fork wrench 10 × 14	MAZU 2/1 X
10	1	Gabelschlüssel 17×19	hexagon fork wrench 17 × 19	17 × 19 DIN 895
11	1	Gabelschlüssel 22×24	hexagon fork wrench 22 × 24	MAZU 11/1 X
12	1	Sechskantstiftschlüssel SW 5	hexagon socket-screw wrench	MBZU 1/5 X
13	1	Sechskantstiftschlüssel SW 6	hexagon socket-screw wrench	MBZU 1/6 X
14	1	Sechskantstiftschlüssel SW 8	hexagon socket-screw wrench	MBZU 1/8 X
15	1	Sechskantstiftschlüssel SW 10	hexagon socket-screw wrench	MBZU 1/10 X
16	1	Sechskantstiftschlüssel SW 4	hexagon socket-screw wrench	MBZU 1/4 X
17	1	Fettpresse zur Schmierung des Getriebes am Antriebsmotor und des Antriebes im Magnetongerät		UZ 101 WE 3/1 Z

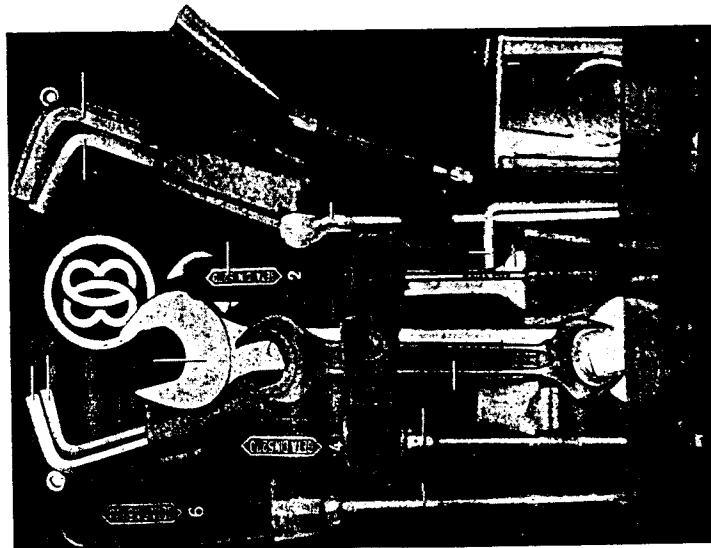

Lfd. Nr.	ERSATZTEIL-LISTE	SPARE PART LIST	Standard-Ausführung	U.S.A.-Type
No.	Magnetton-Abtastgerät	Magnetic Sound Reproducer	F 534	F 536
1	Gehäuse	Housing	Y-KI Ifw 25 Tz 98	Y-KI Ifw 25 T 68
1.01	Deckel	cover	Y-KI Ifw 25 T 164	Y-KI Ifw 25 T 164
1.02	Anschlußleiste	joining gib	—	Y-KI Ifw 25 Tz 53
1.03	Zylinderschraube	cheese head screw	AM 3×5 DIN 84 ⁹³³	AM 3×5 DIN 84 ⁹³³
1.04	Zylinderschraube	cheese head screw	M 5×30 DIN 912 ⁹³³	M 5×30 DIN 912 ⁹³³
1.05	Zylinderschraube	cheese head screw	M 6×15 DIN 912 ⁹³³	M 6×15 DIN 912 ⁹³³
1.06	Leitungsschelle	pipe clip	Y-A 9 S & H Nr. 7855	Y-A 9 S & H Nr. 7855
1.07	Anthygronstützen	muff	Y-AFJ st 21 SSW	—
1.08	Linsenschraube	lens head screw	AM 4×10 DIN 85 ⁹³³	—
1.09	Scheibe	disc	4,3 DIN 433 ⁹³³	—
2	Platine, vollständig	Base plate, complete	Y-KI Ifw 25 Tz 80	Y-KI Ifw 25 Tz 79
2.01	Zylinderschraube	cheese head screw	AM 4×12 DIN 84 ⁹³³	AM 4×12 DIN 84 ⁹³³
2.02	Zylinderschraube	cheese head screw	AM 4×15 DIN 84 ⁹³³	AM 4×15 DIN 84 ⁹³³
2.03	Scheibe	disc	4,3 DIN 125	4,3 DIN 125
2.04	Schraube	screw	Y-KI Ifw 25 T 59	Y-KI Ifw 25 T 59
2.05	Federring	spring ring	B 4 DIN 127	B 4 DIN 127
2.06	Hebel vollständig	lever, complete	Y-KI Ifw 25 Tz 74	Y-KI Ifw 25 Tz 74
2.07	Luftdämpfer	air damper	Y-KI FZ 078	Y-KI FZ 078
2.08	Zylinderschraube	cheese head screw	AM 4×12 DIN 84 ⁹³³	AM 4×12 DIN 84 ⁹³³
2.09	Scheibe	disc	4,3 DIN 433	4,3 DIN 433
2.10	Federring	spring ring	B 4 DIN 127	B 4 DIN 127
2.11	Sechskantmutter	hexagon nut	M 4 DIN 934 ⁹³³	M 4 DIN 934 ⁹³³
2.12	Sicherungsscheibe	lock washer	Y-3,2 DIN 6799-X 40 Cr 13	Y-3,2 DIN 6799-X 40 Cr 13
2.13	Fächerscheibe	fan-type washer	Y-A 4,3 DIN 6798 phosphatiert	Y-A 4,3 DIN 6798 phosphatiert
2.14	Bolzen	bolt	Y-KI Ifw 25 T 170	Y-KI Ifw 25 T 170
2.15	Scheibe	disc	4,3 DIN 125	4,3 DIN 125

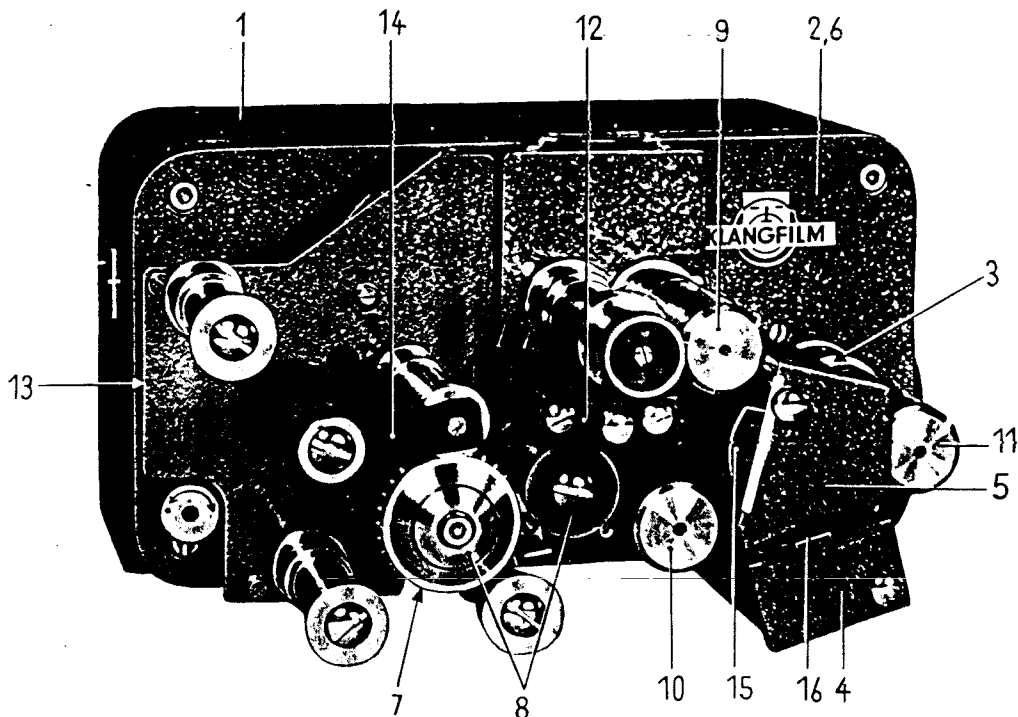

Lfd. Nr.	ERSATZTEIL-LISTE	SPAREPARTLIST	Standard-Ausführung	U.S.A.-Type
No.	Magnetton-Abtastgerät	Magnetic Sound Reproducer	F 534	F 536
2.16	Sechskantmutter	hexagon nut	M 4 DIN 934 ⁸³³	M 4 DIN 934 ⁸³³
2.17	Winkel, vollständig	elbow, complete	Y-KI lfw 25 Tz 57	Y-KI lfw 25 Tz 57
2.18	Sicherungsscheibe	lock washer	Y-3,2 DIN 6799-X 40 Cr 13	Y-3,2 DIN 6799-X 40 Cr 13
2.19	Zugfeder	tension spring	Y-KI lfw 25 T 149	Y-KI lfw 25 T 149
2.20	Scheibe	disc	Y-KI lfw 25 T 217 o. T 218 nach Bedarf	Y-KI lfw 25 T 217 o. T 218 if requ.
2.21	Knopf, vollständig	knurled knob	Y-KI lfw 25 Tz 17	Y-KI lfw 25 Tz 17
2.22	Hutmutter	cap nut	Y-KI lfw 25 T 17	Y-KI lfw 25 T 17
2.23	Zugfeder	tension spring	Y-KI lfw 25 T 148	Y-KI lfw 25 T 148
2.24	Platte, vollständig	plate, complete	Y-KI lfw 25 Tz 41	Y-KI lfw 25 Tz 41
2.25	Zylinderschraube	cheese head screw	AM 3 x 6 DIN 84 ⁸³³	AM 3 x 6 DIN 84 ⁸³³
2.26	Rolle	roller	Y-KI lfw 25 T 125	Y-KI lfw 25 T 125
2.27	Sicherungsscheibe	lock washer	Y-3,2 DIN 6799-X 40 Cr 13	Y-3,2 DIN 6799-X 40 Cr 13
2.28	Band, vollständig	stell band, complete	Y-KI lfw 25 Tz 39	Y-KI lfw 25 Tz 39
2.29	Zugfeder	tension spring	Y-KI lfw 25 T 147	Y-KI lfw 25 T 147
2.30	Knopf	knurled knob	Y-KI lfw 25 T 203	Y-KI lfw 25 T 203
2.31	Scheibe	disc	Y-KI lfw 25 T 133	Y-KI lfw 25 T 133
2.32	Scheibe	disc	Y-KI lfw 25 T 134	Y-KI lfw 25 T 134
2.33	Sternfeder	star-shaped spring washer	Y-21,7 x 11 x 0,5 handelsüblich	Y-21,7 x 11 x 0,5 commercial
2.34	Ring	ring	Y-KI lfw 25 T 131	Y-KI lfw 25 T 131
2.35	Zapfenschraube	screw	Y-M 4 x 4 DIN 927/649	Y-M 4 x 4 DIN 927/649
2.36	Scheibe	disc	Y-KI lfw 25 T 202	Y-KI lfw 25 T 202
2.37	Federring	spring ring	B 5 DIN 127	B 5 DIN 127
2.38	Zylinderschraube	cheese head screw	AM 5 x 8 DIN 84 ⁸³³	AM 5 x 8 DIN 84 ⁸³³
2.39	Zylinderschraube	cheese head screw	M 2 x 5 DIN 84 ⁸³³	M 2 x 5 DIN 84 ⁸³³
2.40	Abdeckplatte, vollständig	cover-plate, complete	Y-KI lfw 25 Tz 75	Y-KI lfw 25 Tz 75
2.41	Linsenschraube	lens head screw	BM 4 x 35 DIN 84 ⁸³³	BM 4 x 35 DIN 84 ⁸³³
2.42	Scheibe	disc	B 4 DIN 127	B 4 DIN 127
2.43	Achse	shaft	Y-KI lfw 25 T 69	Y-KI lfw 25 T 69
2.44	Rolle	roller	Y-KI lfw 25 T 216	Y-KI lfw 25 T 216
2.45	Hutmutter (ident. mit Pos. 2.22)	cap nut (identical with item 2.22)	Y-KI lfw 25 T 17	Y-KI lfw 25 T 17
2.46	Scheibe	disc	Y-KI lfw 25 T 265 n. Bed.	Y-KI lfw 25 T 265 if requ.
2.47	Platte	plate	Y-KI lfw 25 T 63	Y-KI lfw 25 T 63
2.48	Leitungsschelle	pipe clip	Y-A 6 S & H Nr. 78550	Y-A 6 S & H Nr. 78550
2.49	Lötöse	soldering eye	Y-3 x 18 A 1 DIN 41496	Y-3 x 18 A 1 DIN 41496
2.50	Zylinderschraube	cheese head screw	AM 3 x 6 DIN 84 ⁸³³	AM 3 x 6 DIN 84 ⁸³³
2.51	Zylinderschraube	cheese head screw	AM 4 x 18 DIN 84 ⁸³³	AM 4 x 18 DIN 84 ⁸³³
2.52	Scheibe	disc	4,3 DIN 125	4,3 DIN 125
2.53	Zylinderschraube	cheese head screw	AM 4 x 12 DIN 84 ⁸³³	AM 4 x 12 DIN 84 ⁸³³
2.54	Scheibe	disc	4,3 DIN 125 ⁸³³	4,3 DIN 125 ⁸³³
2.55	Lötleiste	soldering strip	Y-KI lfw 25 Tz 26	—
2.551	Lötleiste	soldering strip	Y-T ale 32b	—
2.552	Schiene	rod	Y-KI lfw 25 T 76	—
2.553	Winkel	elbow	Y-KI lfw 25 T 77	—
2.554	Zylinderscheibe	cylindric disc	AM 3 x 4 DIN 84 ⁸³³	—
3	Platte, vollständig	Plate, complete	Y-KI lfw 25 Tz 20	Y-KI lfw 25 Tz 20
3.01	Spannstift	tension pin	1,5 x 5 DIN 1481	1,5 x 5 DIN 1481
3.02	Seeger-Sicherungsring	locking ring	16 x 1 DIN 471	16 x 1 DIN 471
3.03	Steckerstift	plug pin	Y-6 KI stv 3a	Y-6 KI stv 3a
3.04	Platte	plate	Y-K 1 lfw T 62	Y-KI lfw 25 T 62
3.05	Federring	spring ring	B 5 DIN 127	B 5 DIN 127
3.06	Zylinderschraube	cheese head screw	BM 5 x 45 DIN 84 ⁸³³	BM 5 x 45 DIN 84 ⁸³³
4	Platte, vollständig	Plate, complete	Y-KI lfw 25 Tz 71	Y-KI lfw 25 Tz 71
4.01	Zwischenplatte	intermediate plate	Y-KI lfw 25 T 60	Y-KI lfw 25 T 60
4.02	Senkschraube	countersunk head screw	AM 2,3 x 6 DIN 84 ⁸³³	AM 2,3 x 6 DIN 84 ⁸³³
4.03	Platte	plate	Y-KI mak 37 T 12	Y-KI mak 37 T 12
4.04	Büchsenleiste	socket	Y-T 2656 handelsüblich (Tuchel)	Y-T 2656 commercial (Tuchel)
4.05	Zylinderschraube	cheese head screw	AM 2 x 6 DIN 84 ⁸³³	AM 2 x 6 DIN 84 ⁸³³
4.06	Zylinderschraube	cheese head screw	AM 4 x 25 DIN 84 ⁸³³	AM 4 x 25 DIN 84 ⁸³³

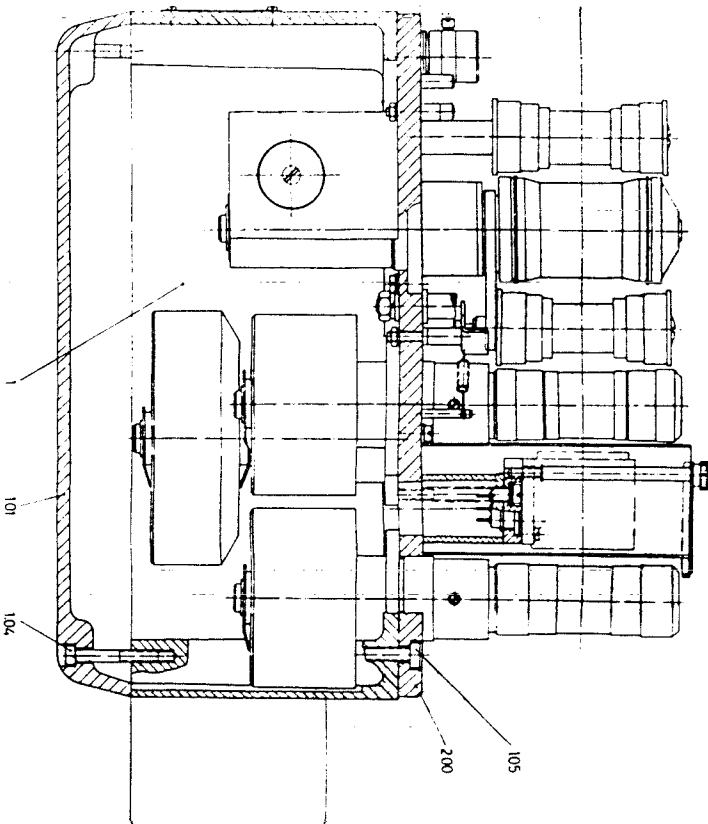

Magnetion - Ablastgerat
USA-Ausführung

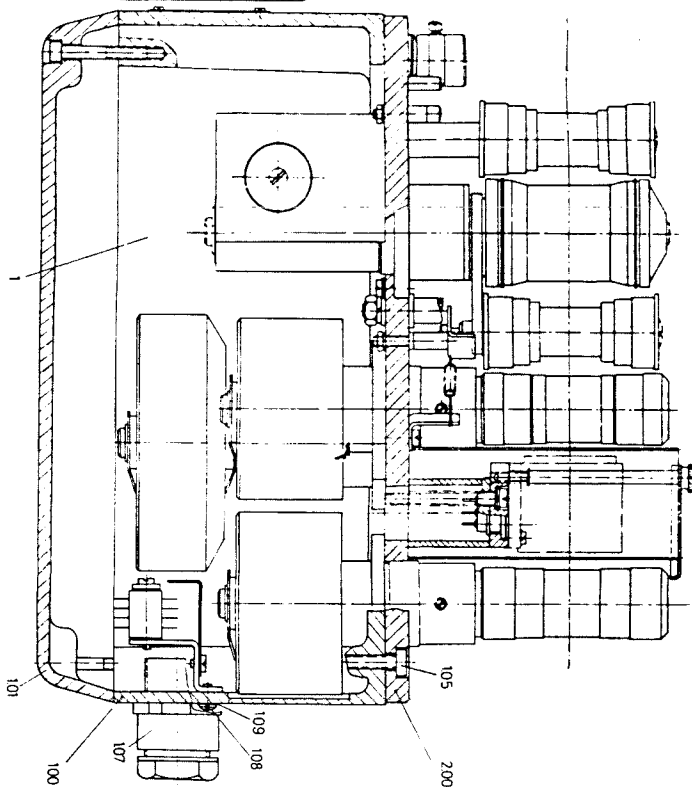

Magnetion - Ablastgerat
Standard-Ausführung

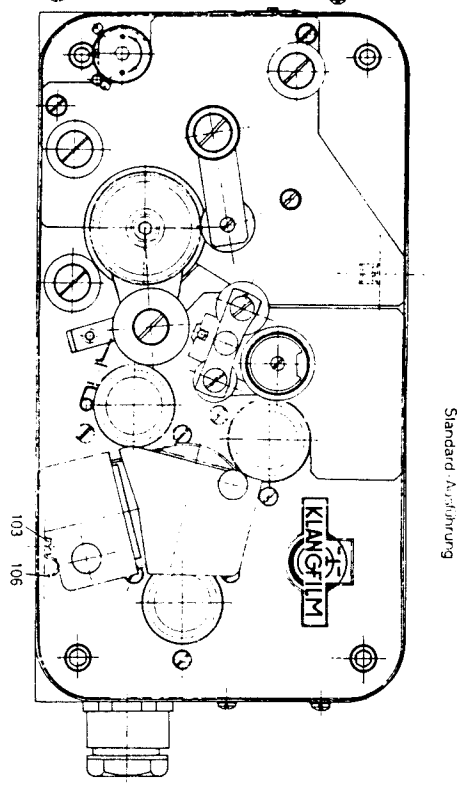
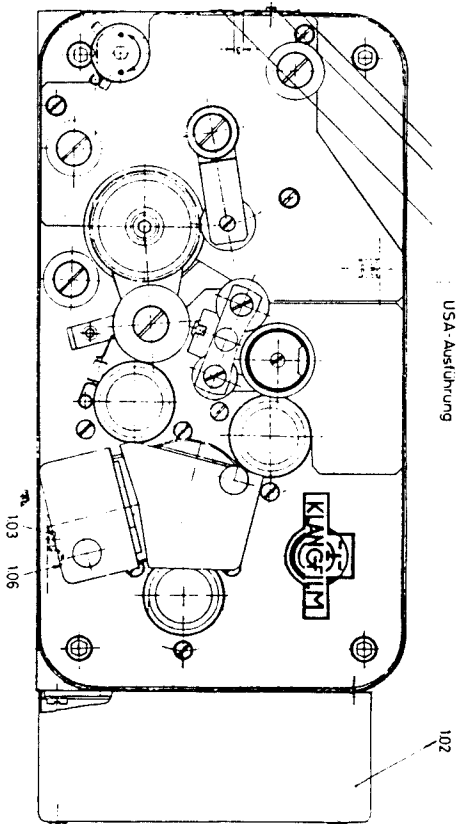

Lfd. Nr.	ERSATZTEIL-LISTE	SPARE PART LIST	Standard-Ausführung	U.S.A.-Type
No.	Magnetton-Abtastgerät	Magnetic Sound Reproducer	F 534	F 536
5	Abschirmhaube, vollständig	Screening cap, compl.	Y-KI lfw 25 Tz 48	Y-KI lfw 25 Tz 48
5.01	Befestigungsschraube	fastening screw	Y-KI lfw 25 T 150	Y-KI lfw 25 T 150
5.02	Befestigungsschraube	fastening screw	Y-KI lfw 25 T 151	Y-KI lfw 25 T 151
5.03	Abschirmhaube	screening cap	Y-KI lfw 25 Tz 47	Y-KI lfw 25 Tz 47
5.04	Scheibe	disc	Y-KI lfw 25 T 146	Y-KI lfw 25 T 146
6	Platine mit Kupplungsteil	Base plate with coupling part	Y-KI lfw 25 Tz 78	Y-KI lfw 25 Tz 78
6.01	Platine mit Einpreßteilen	base plate with bearing bushes	Y-KI lfw 25 Tz 76	Y-KI lfw 25 Tz 76
6.02	Achse	shaft [only]	Y-KI lfw 25 T 58	Y-KI lfw 25 T 58
6.03	Sechskantmutter	hexagon nut	M 6 DIN 934 ⁹³³	M 6 DIN 934 ⁹³³
6.04	Federring	spring ring	B 6 DIN 127	B 6 DIN 127
6.05	Scheibe	disc	6,4 DIN 125	6,4 DIN 125
6.06	Zylinderschraube	cheese head screw	AM 5x15 DIN 84 ⁹³³	AM 5x15 DIN 84 ⁹³³
6.07	Zylinderstift	cylindric pin	Y-4x14 S & H N 6302	Y-4x14 S & H N 6302
6.08	Zylinderschraube	cheese head screw	AM 4x10 DIN 84 ⁹³³	AM 4x10 DIN 84 ⁹³³
6.09	Scheibe	disc	4,3 DIN 125 ⁹³³	4,3 DIN 125 ⁹³³
6.10	Federring	spring ring	B 4 DIN 127	B 4 DIN 127
7	Kupplungsteil	Coupling part	Y-KI lfw 25 Tz 25	Y-KI lfw 25 Tz 25
7.01	Lagerbock	bearing block	Y-KI lfw 25 T 75	Y-KI lfw 25 T 75
7.02	Seeger-Sicherungsring	spring clip	28x1,2 DIN 472	28x1,2 DIN 472
7.04	Zahnradwelle	sprocket shaft	Y-KI lfw 25 T 71	Y-KI lfw 25 T 71
7.08	Scheibe	disc	Y-KI lfw 25 T 73	Y-KI lfw 25 T 73
7.09	Senkschraube	countersunk screw	AM 4x10 DIN 63 ⁹³³	AM 4x10 DIN 63 ⁹³³
7.10	Kupplungsscheibe, vollst.	coupling flange, compl.	Y-KI lfw 25 Tz 24	Y-KI lfw 25 Tz 24
7.11	Scheibenfeder	plate spring	Y-2x2,6 DIN 6888	Y-2x2,6 DIN 6888
7.12	Scheibe	disc	Y-KI lfw 25 T 74	Y-KI lfw 25 T 74
7.13	Hülse	socket	Y-KI lfw 25 T 2	Y-KI lfw 25 T 2
7.14	Rillenkugellager	grooved ball bearing	Y-Hg Kf Typ 6001 DIN 625	Y-Hg Kf Typ 6001 DIN 625
7.15	Scheibe	disc	2,8 DIN 433 St/649	2,8 DIN 433 St/649
7.16	Federring	spring ring	B 2,6 DIN 127/649	B 2,6 DIN 127/649
7.17	Zylinderschraube	cheese head screw	AM 2,6x10 DIN 84-5s/649	AM 2,6x10 DIN 84-5s/649
7.18	Schmierdüse	lubricating nozzle	Y-KI-KZ 034	Y-KI-KZ 034
8	Transportrolle	Sprocket	Y-KI lfw 25 Tz 77	Y-KI lfw 25 Tz 77
8.01	Hülse	socket	Y-KI lfw 25 Tz 206	Y-KI lfw 25 Tz 206
8.02	Welle, vollständig	shaft, complete	Y-KI lfw 25 Tz 13	Y-KI lfw 25 Tz 13
8.03	Rillenkugellager	grooved ball bearing	Y-Typ 6001-2 Z DIN 625	Y-Typ 6001-2 Z DIN 625
8.04	Rillenkugellager	grooved ball bearing	Y-Hg Kf Typ 6001 DIN 625	Y-Hg Kf Typ 6001 DIN 625
8.05	Sicherungsring	locking ring	Y-28x1,2 DIN 472x40 Cr 13	Y-28x1,2 DIN 472x40 Cr 13
8.06	Wellenring	ring	Y-KI antr 27 T 31	Y-KI antr 27 T 31
8.07	Hülse	socket	Y-KI lfw 25 T 31	Y-KI lfw 25 T 31
8.08	Zahnrad	gear	Y-KI lfw 25 T 72	Y-KI lfw 25 T 72
8.09	Zylinderschraube	cheese head screw	AM 4x12 DIN 84 ⁹³³	AM 4x12 DIN 84 ⁹³³
8.10	Federring	spring ring	B 4 DIN 127	B 4 DIN 127
8.11	Scheibe	disc	Y-KI lfw 11 T 28 o.n.B.	Y-KI lfw 11 T 28 o. if requ.
	Scheibe	disc	Y-KI lfw 11 T 29	Y-KI lfw 11 T 29
8.12	Scheibe	disc	Y-KI lfw 25 T 9	Y-KI lfw 11 T 9
8.13	Sicherungsscheibe	lock washer	Y-10 DIN 6799-x40 Cr 13	Y-10 DIN 6799-x40 Cr 13
8.14	Buchse	bush	Y-KI lfw 25 T 207	Y-KI lfw 25 T 207
8.15	Zylinderschraube	cheese head screw	AM 3x8 DIN 84 ⁹³³	AM 3x8 DIN 84 ⁹³³
8.16	Ring	ring	Y-KI lfw 25 T 200 n. B.	Y-KI lfw 25 T 200 if requ.
8.17	Nadelkäfig	needle cage	Y-K 20/13-Fa. Schaeffler, Herzogenaurach	Y-K 20/13-Fa. Schaeffler, Herzogenaurach
8.18	Ring	ring	Y-KI lfw 25 T 208	Y-KI lfw 25 T 208 if requ.
8.19	Hebel, vollständig	lever, complete	Y-KI lfw 25 Tz 73	Y-KI lfw 25 Tz 73
8.20	Ring	ring	Y-KI lfw 25 T 201	Y-KI lfw 25 T 201
8.21	Gewindestift	threaded pin	M 2,3x5 DIN 551 ⁹³³	M 2,3x5 DIN 551 ⁹³³
8.22	Platte	plate	Y-KI lfw 25 T 272	Y-KI lfw 25 T 272
8.23	Transportrolle 70 mm, vollst.	sprocket 70 mm, compl.	Y-KI lfw 25 Tz 55 oder	Y-KI lfw 25 Tz 55 oder
8.24	Transportrolle 35 mm, vollst.	sprocket 35 mm, compl.	Y-KI lfw 25 Tz 56	Y-KI lfw 25 Tz 56
8.25	Konusschraube	cone screw	Y-KI lfw 25 T 38	Y-KI lfw 25 T 38
8.26	Rolle	roller	Y-KI lfw 25 Tz 100	Y-KI lfw 25 Tz 100
8.27	Mutter	nut	Y-KI lfw 25 T 17	Y-KI lfw 25 T 17

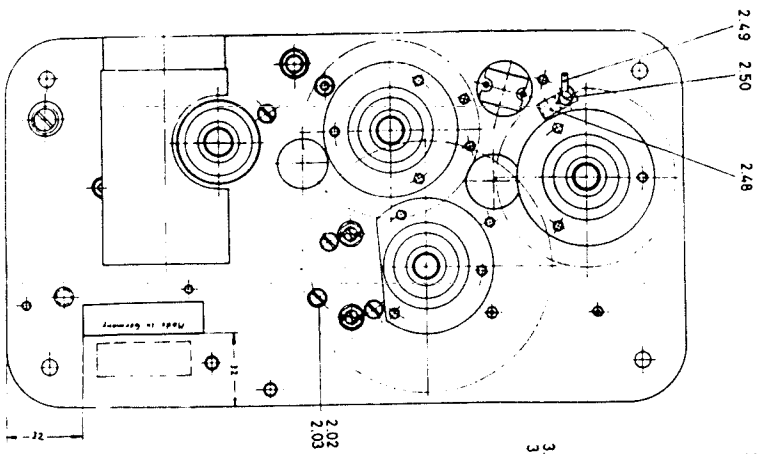

Schnitt E-F

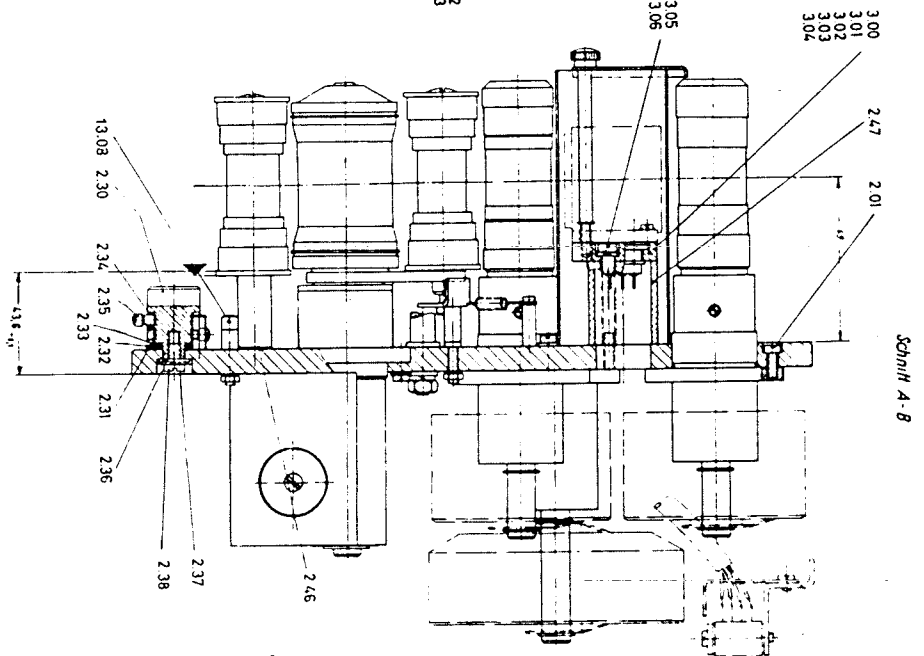
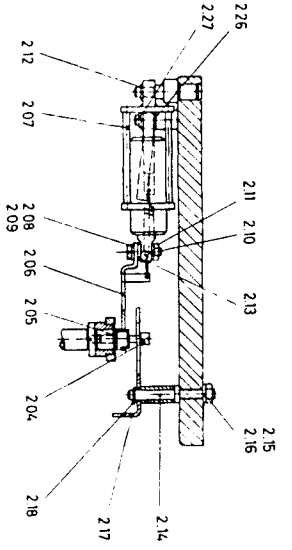

Schnitt A-B

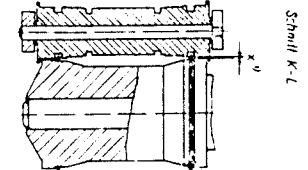

Schnitt K-L

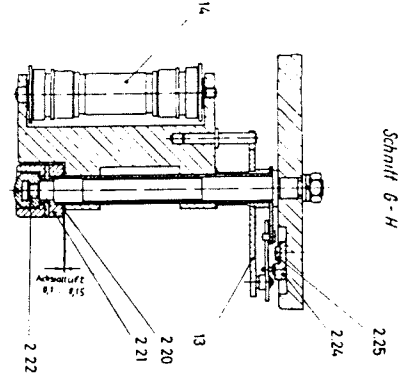

Schnitt G-H

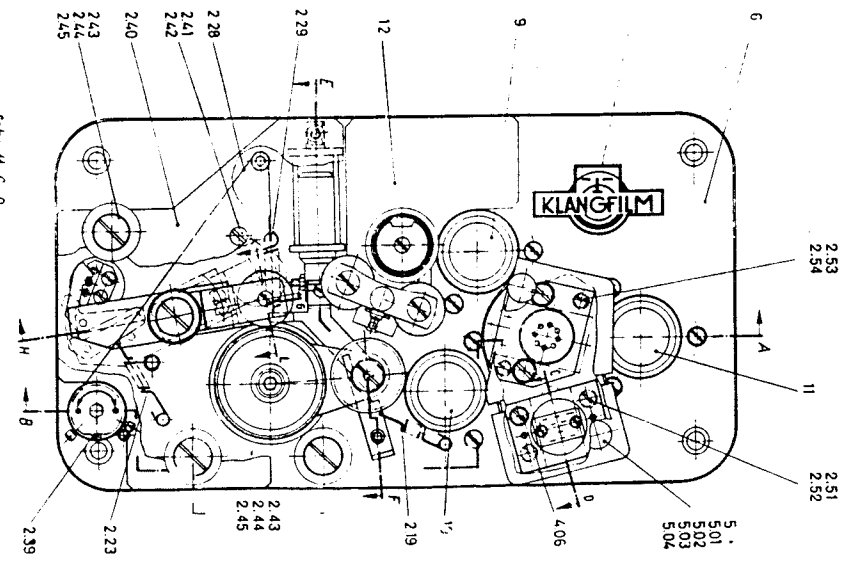

Schnitt C-D

Platine vollständig
KI Ilw 25 12 79/80

Lfd. Nr.	ERSATZTEIL-LISTE	SPARE PART LIST	Standard-Ausführung	U.S.A.-Type
No.	Magnetton-Abtastgerät	Magnetic Sound Reproducer	F 534	F 536
9	Tonrolle, vollständig	Sound roller, complete	Y-KI lfw 25 Tz 1	Y-KI lfw 25 Tz 1
9.01	Welle, vollständig	shaft, complete	Y-KI lfw 25 Tz 4	Y-KI lfw 25 Tz 4
9.02	Hülse	socket	Y-KI lfw 25 T 5	Y-KI lfw 25 T 5
9.03	Buchse	bush	Y-KI lfw 25 T 176	Y-KI lfw 25 T 176
9.04	Wellenring	ring	Y-KI antr 27 T 31	Y-KI antr 27 T 31
9.05	Rillenkugellager	grooved ball bearing	Y-Hg Kf Typ 6001 DIN 625	Y-Hg Kf Typ 6001 DIN 625
9.06	Sicherungsring	locking ring	28x1,2 DIN 472	28x1,2 DIN 472
9.07	Scheibe n. B.	disc	Y-KI lfw 11 T 28 o. T 29	Y-KI lfw 11 T 28 o. T 29
9.08	Scheibe	disc	Y-KI lfw 25 T 9	Y-KI lfw 25 T 9
9.09	Sicherungsscheibe	lock ring	Y-10 DIN 6799-x 40 Cr 13	Y-10 DIN 6799-x 40 Cr 13
9.10	Feder	spring	Y-KI lfw 15 T 126	YLKI lfw 15 T 126
9.11	Gummischeibe	rubber disc	Y-6 Ela div 519	Y-6 Ela div 519
9.12	Schwungmasse	fly wheel mass	Y-KI lfw 25 T 10	Y-KI lfw 25 T 10
10	Tonrolle, vollständig	Sound roller, complete	Y-KI lfw 25 Tz 2	Y-KI lfw 25 Tz 2
10.01	Welle, vollständig	shaft complete	Y-KI lfw 25 Tz 6	Y-KI lfw 25 Tz 6
10.02	Hülse	socket	Y-KI lfw 25 T 6	Y-KI lfw 25 T 6
10.03	Buchse	bush	Y-KI lfw 25 T 177	Y-KI lfw 25 T 177
10.04	Schwungmasse	flywheel mass	Y-KI lfw 25 T 11	Y-KI lfw 25 T 11
11	Tonrolle, vollständig	Sound roller, complete	Y-KI lfw 25 Tz 3	Y-KI lfw 25 Tz 3
11.01	Welle, vollständig	shaft, complete	Y-KI lfw 25 Tz 5	Y-KI lfw 25 Tz 5
11.02	Hülse	socket	Y-KI lfw 25 T 6	Y-KI lfw 25 T 6
11.03	Buchse	bush	Y-KI lfw 25 T 177	Y-KI lfw 25 T 177
11.04	Schwungmasse	flywheel mass	Y-KI lfw 25 T 11	Y-KI lfw 25 T 11
12	Schleifenfänger	Loop filter	Y-KI lfw 25 Tz 93	Y-KI lfw 25 Tz 92
12.01	Platte, vollständig	plate complete	Y-KI lfw 25 Tz 89	Y-KI lfw 25 Tz 91
12.02	Rohr, vollständig	tube, complete	Y-KI lfw 25 Tz 85	Y-KI lfw 25 Tz 85
12.03	Sicherungsring	locking ring	Y-15x1 DIN 471	Y-15x1 DIN 471
12.04	Scheibe, n. B.	disc	Y-KI lfw 25 T 255	Y-KI lfw 25 T 255
12.05	Rolle	roller	Y-KI lfw 25 T 233	Y-KI lfw 25 T 233
12.06	Sicherungsring	locking ring	Y-18x1,2 DIN 471	Y-18x1,2 DIN 471
12.061	Scheibe, n. B.	disc	Y-KI lfw 25 T 256	Y-KI lfw 25 T 256
12.07	Hebel, vollständig	lever, complete	Y-KI lfw 25 Tz 86	Y-KI lfw 25 Tz 86
12.08	Hebel, vollständig	lever, complete	Y-KI lfw 25 Tz 87	Y-KI lfw 25 Tz 87
12.081	Sicherungsscheibe	lock washer	Y-2,3 DIN 6799	Y-2,3 DIN 6799
12.09	Sicherungsscheibe	lock washer	Y-3,2 DIN 6799	Y-3,2 DIN 6799
12.10	Achse, vollständig	shaft, complete	Y-KI lfw 25 Tz 88	Y-KI lfw 25 Tz 88
12.11	Drehknopf	knob	Y-KI lfw 25 T 247	Y-KI lfw 25 T 247
12.12	Gewindestift	treated pin	Y-M 4x4x2 DIN 926	Y-M 4x4x2 DIN 926
12.13	Scheibe	disc	Y-KI lfw 25 T 254	Y-KI lfw 25 T 254
12.14	Druckfeder	pressure pin	Y-KI lfw 25 T 257	Y-KI lfw 25 T 257
12.15	Scheibe	disc	Y-KI lfw 25 T 246	Y-KI lfw 25 T 246
12.16	Linsensenkschraube	countersunk head screw	AM 3x8 DIN 91-5s/649 Kopf 653	AM 3x8 DIN 91-5s/649 head 653
12.17	Scheibe	disc	Y-KI lfw 25 T 252	Y-KI lfw 25 T 252
12.18	Senkschraube	countersunk screw	AM 2,3x6 DIN 63 ³³	AM 2,3x6 DIN 63 ³³
12.19	Schraube	screw	Y-KI lfw 25 T 113	Y-KI lfw 25 T 113
12.20	Gewindehülse	bush	Y-KI lfw 25 T 114	Y-KI lfw 25 T 114
12.21	Rollenhalter	roller assembly	Y-KI lfw 25 Tz 81	Y-KI lfw 25 Tz 81
12.22	Seeger-Sprengring	spring ring	Y-Sw 7 Fa. Orbis	Y-Sw 7 Fa. Orbis
12.23	Scheibe n. B.	disc	Y-KI lfw 25 T 258	Y-KI lfw 25 T 258
12.24	Gummirolle, vollständig	rubber roller, complete	Y-KI lfw 25 Tz 33	Y-KI lfw 25 Tz 33
12.25	Gummirolle, vollständig	rubber roller, complete	Y-KI lfw 25 Tz 35	Y-KI lfw 25 Tz 35
12.26	Achse	shaft	Y-KI lfw 25 T 229	Y-KI lfw 25 T 229
12.27	Platte, vollständig	plate, complete	Y-KI lfw 25 Tz 83	Y-KI lfw 25 Tz 83
12.28	Sicherungsscheibe	lock washer	Y-5 DIN 6799	Y-5 DIN 6799
12.29	Bolzen, vollständig	bolt, complete	Y-KI lfw 25 Tz 84	Y-KI lfw 25 Tz 84
12.371	Zugfeder	tension spring	Y-KI lfw 25 T 270	Y-KI lfw 25 T 270
12.372	Bolzen	bolt	Y-KI lfw 25 Tz 95	Y-KI lfw 25 Tz 95
12.381	Zugfeder	tension spring	Y-KI lfw 25 T 269	Y-KI lfw 25 T 269
12.382	Bolzen	bolt	Y-KI lfw 25 Tz 94	Y-KI lfw 25 Tz 94
12.39	Mikroschalter	micro switch	Y-Nr. 1001 Fa. Marquardt mit Lötanschluß	

Lfd. Nr. No.	ERSATZTEIL-LISTE Magnetton-Abtastgerät	SPARE PART LIST Magnetic Sound Reproducer	Standard-Ausführung F 534	U.S.A.-Type F 536
12.40	Zylinderschraube	cheese head screw	M 2,6×15 DIN 84 ⁹⁹³	—
12.41	Winkel	elbow	Y-KI lfw 25 T 264	—
12.42	Streifen	loop stabilizer	Y-KI lfw 25 T 262	—
12.43	Sicherungsscheibe	lock washer	2,3 DIN 6799	—
12.44	Druckfeder	tension spring	Y-KI lfw 25 T 231	Y-KI lfw 25 T 231
12.45	Druckknopf	push button	Y-KI lfw 25 T 232	Y-KI lfw 25 T 232
12.48	Haken	hook	Y-KI lfw 25 T 263	—
13	Hebel, vollständig	Lever, complete	Y-KI lfw 25 Tz 43	Y-KI lfw 25 Tz 43
13.01	Rastklinke, vollständig	stop latch	Y-KI lfw 25 Tz 42	Y-KI lfw 25 Tz 42
13.02	Drehfeder	torsion spring	Y-KI lfw 25 T 81	Y-KI lfw 25 T 81
13.03	Sicherungsscheibe	lock washer	Y-2,3 DIN 6799-X 40 Cr 13	Y-2,3 DIN 6799-X 40 Cr 13
13.04	Kupplungshebel	coupling lever	Y-KI lfw 25 Tz 40	Y-KI lfw 25 Tz 40
13.05	Auslösehebel	release lever	Y-KI lfw 25 Tz 11	Y-KI lfw 25 Tz 11
13.06	Seeger Greifring	clamp ring	Y-G 12×1,2	Y-G 12×1,2
13.07	Drehfeder	torsion spring	Y-KI lfw 25 T 82	Y-KI lfw 25 T 82
13.08	Bolzen,vollständig	bolt, complete	Y-KI lfw 25 Tz 15	Y-KI lfw 25 Tz 15
14	Rollenhalter, vollständig	Roller assembly, complete	Y-KI lfw 25 Tz 19	Y-KI lfw 25 Tz 19
14.01	Rollenhalter mit Stift	roller assembly with pin	Y-KI lfw 25 Tz 16	Y-KI lfw 25 Tz 16
14.02	Achse	shaft	Y-KI lfw 25 T 57	Y-KI lfw 25 T 57
14.03	Scheibe	disc	Y-KI lfw 25 T 61	Y-KI lfw 25 T 61
14.04	Rolle	roller	Y-KI lfw 25 T 64	Y-KI lfw 25 T 64
15	4-Spur-Magnetkopf	4-track magn. cluster	Y-C 419 H	Y-C 418 H
16	6-Spur-Magnetkopf	6-track magn. cluster	Y-C 604 H	Y-C 605 H

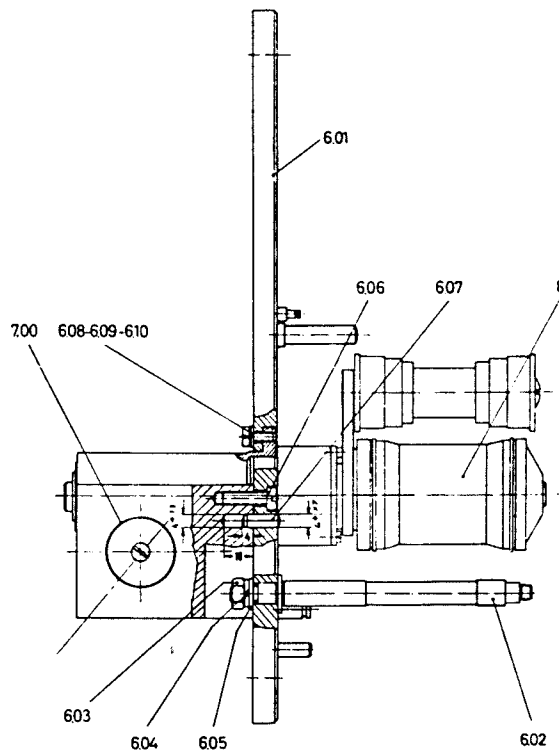

Platine mit Kupplungs-
teil
KI lfw 25 Tz 78

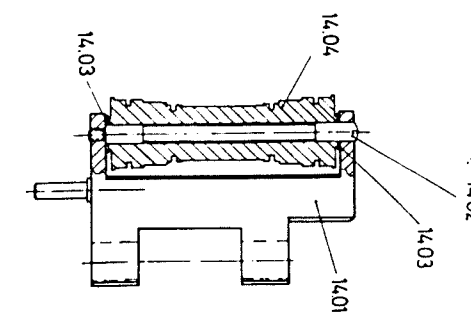
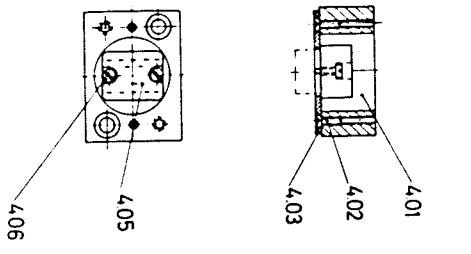
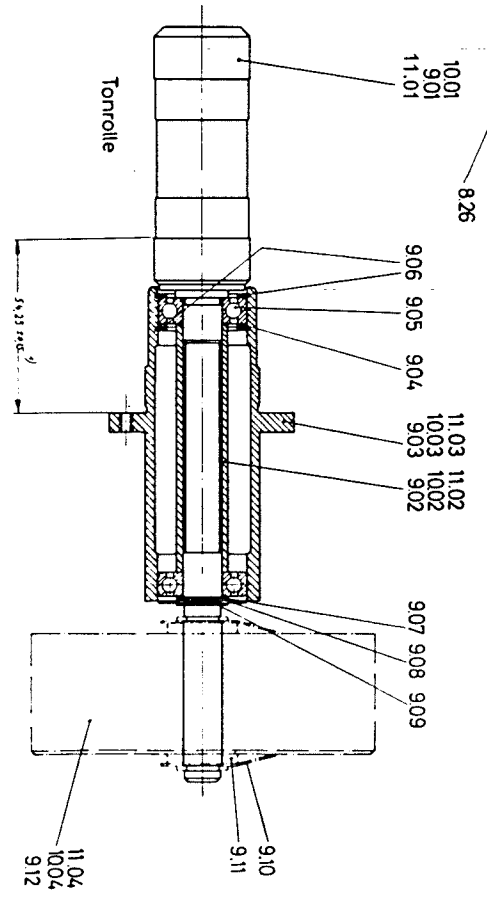
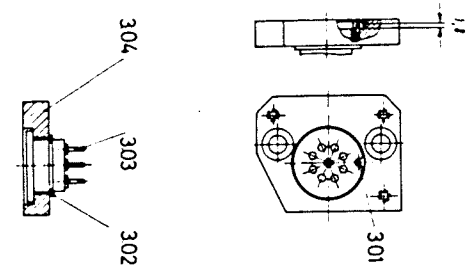
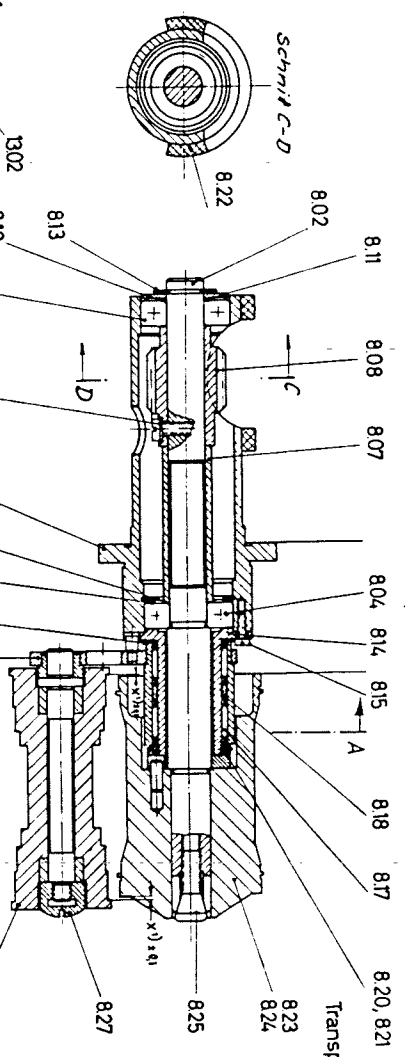
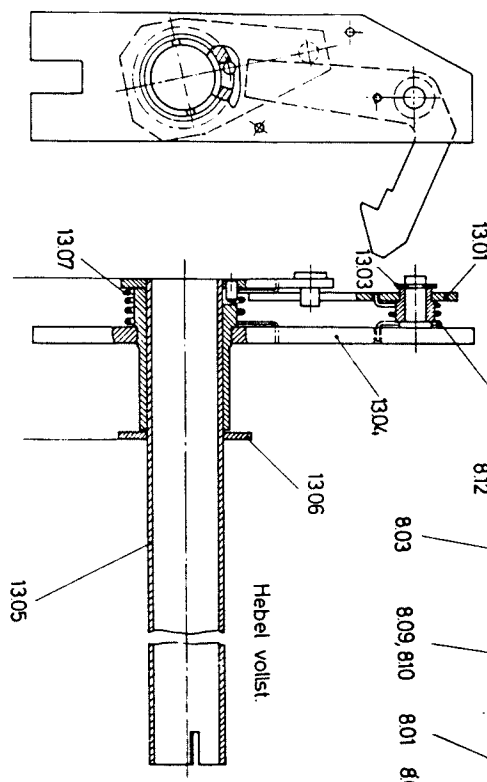
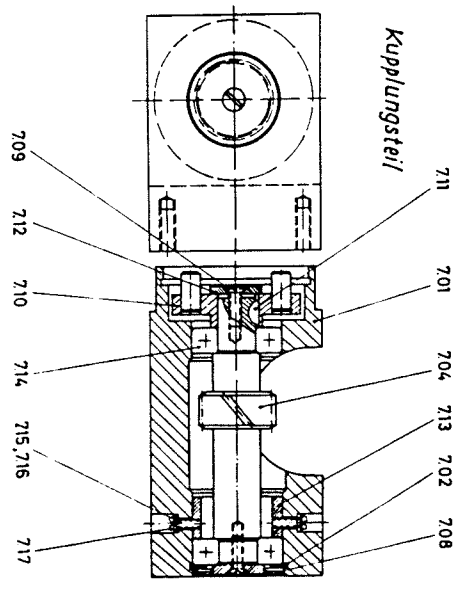

Tonrolle vollst.	Positionen			
9	9.01	9.02	9.03	9.12
10	10.01	10.02	10.03	10.04
11	11.01	11.02	11.03	11.04

Übrige Positionen 9... für alle 3 Tonrollen gleich

Schnitt A-B

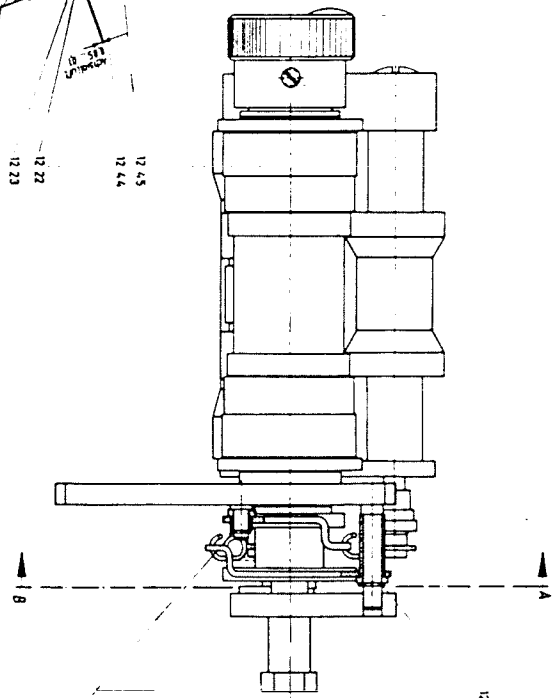
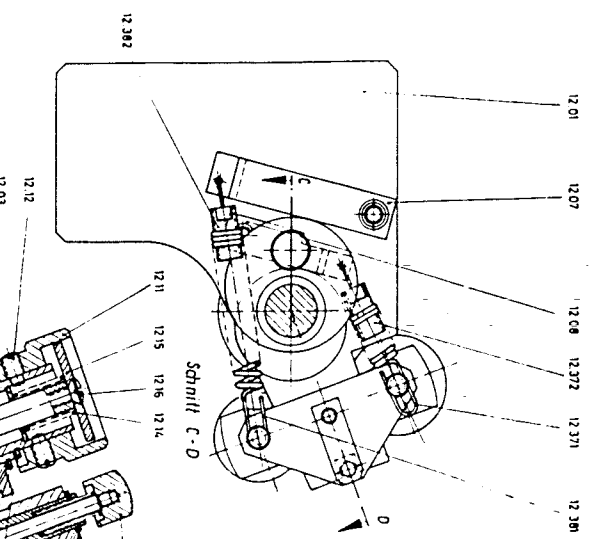

Exzentrierung für 78 mm dargestellt
 Andruckrollen in Nullstellung
 auf Stellung der Pas 1215 gezeichnet (rot sichtbar)
 Anschlag Pas 1217 ist eingestellt, daß
 Pas 1202 sauber einrastet

Schnitt C-D

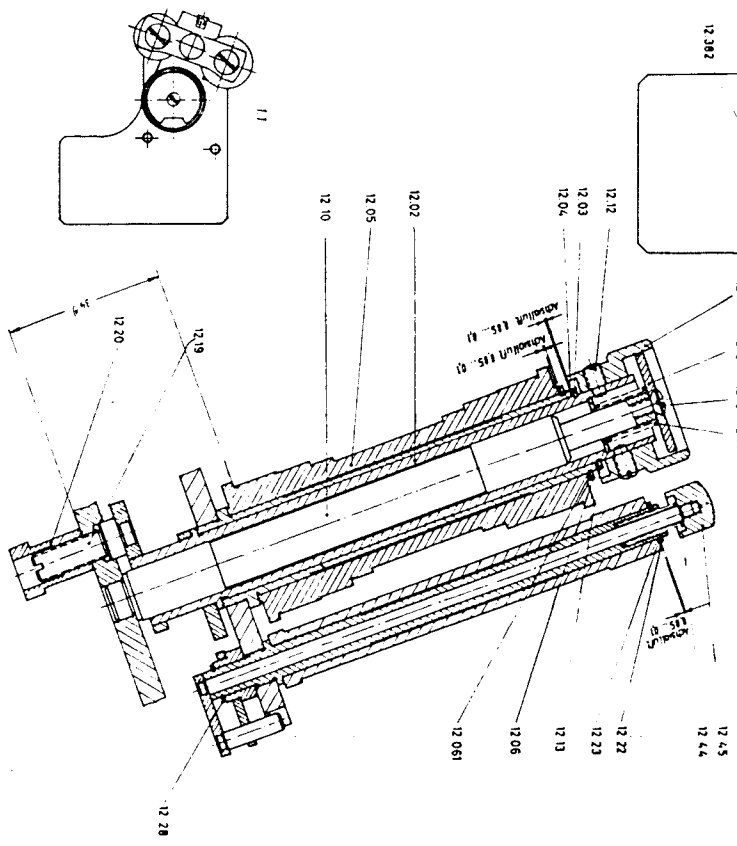

Schnitt E-F

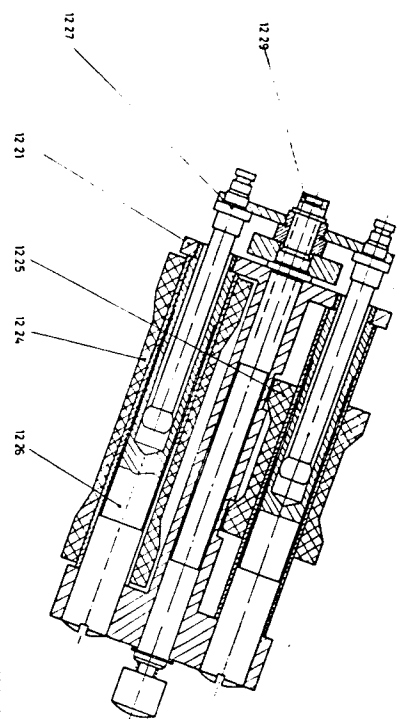

Schleifenfänger Kl. (Iw. 25, Tz. 92)

M. Dr. F. W. 3. 00000000

Schnitt A-B

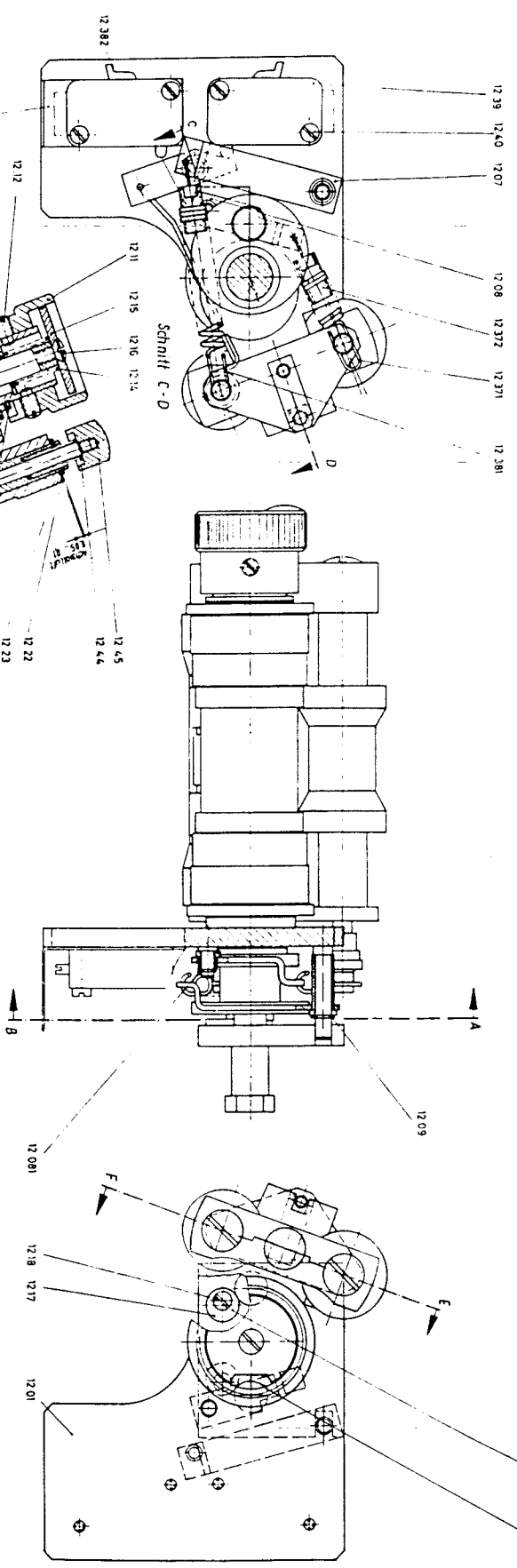

Exzentrierung für 73 mm dargestellt
 Ankerrollen in Ausrichtung
 zur Stellung der PWS 12.15 geschaltet (mit sicher)
 Anschlag Pos 12.17 ist eingestellt, daß
 Pos 12.02 sauber einrastet

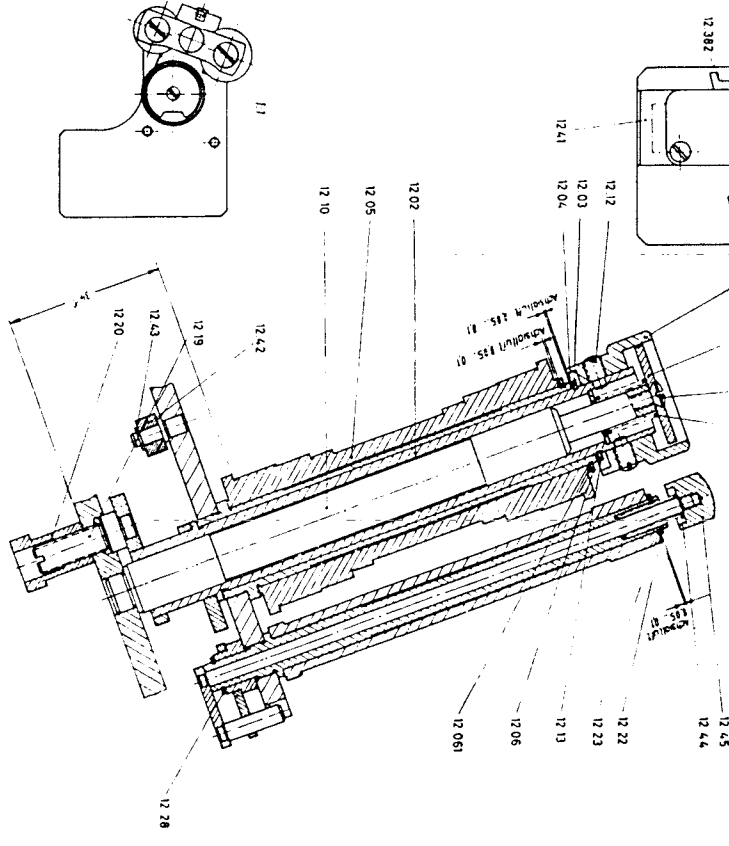

Schleifenfänger Kl. I/IV. 25, Tz. 93

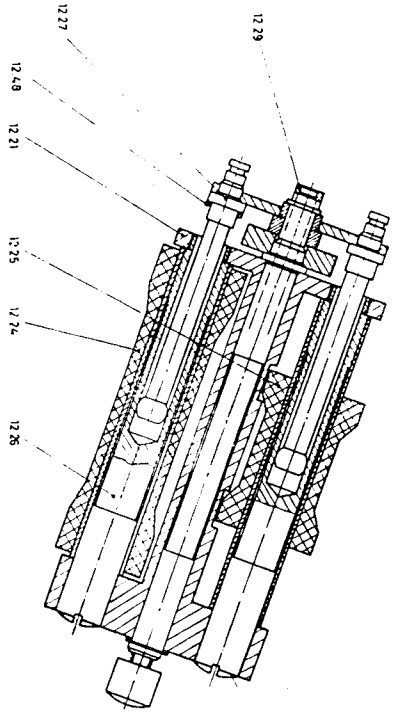

NI. An. 10.3 geschaltet

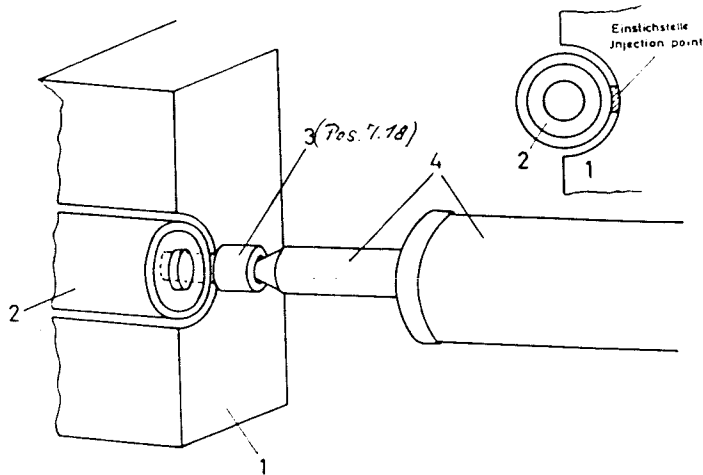

- 1 Getriebekasten
Gearing case
- 2 Zylindrische Lagerhülse
Cylindrical bearing shell
- 3 Vorsatzdüse KI KZ 034
Front nozzle KI KZ 034
- 4 Fettpresse
Grease spray tube

1. Deckel auf der Rückseite des Magnettonabtastgerätes abnehmen (rechts neben der großen Schwungmasse befindet sich der Getriebekasten, siehe auch Bedienungsanleitung Bauer Universal-Tonfilm-Projektor U 2, Seite 7, Bild 4).
2. Mitgelieferte Düse auf Fettspritze setzen.
3. Düse mit Fettspritze an in Skizze gekennzeichnete Stelle ansetzen, d. h. also flaches Vorderteil der Düse in den halbkreisförmigen Spalt zwischen zylindrischer Lagerhülse und Getriebekasten schieben.
4. Etwa 4 ccm Fett* in das Getriebe drücken.
5. Altes herausquellendes Fett entfernen.
6. Deckel des Magnettonabtastgerätes wieder schließen.

Wir empfehlen, die Schmierung in Abständen von etwa 4 Wochen zu wiederholen.

- * Wälzlagerfett ähnlich Calypsol H 442 B, Tropfpunkt 185° C, Asche 0,7—1,2%.

1. Remove cover on rear of magnetic sound reproducer (right hand of the large flywheel the gearing case is situated, also see instruction manual for Bauer Universal Sound Film Projektor U 2, page 7, Fig. 4).
2. Place nozzle supplied with equipment onto grease spray tube.
3. Apply nozzle with grease spray tube at place marked in drawing, i. e. push flat front part of nozzle into semicircular slot between cylindrical bearing shell and gearing case.
4. Press about 4 cu.cm. of grease* into the gearing.
5. Remove the old grease squeezing out.
6. Close cover of magnetic sound reproducer again.

We recommend to repeat the lubrication in intervals of about 4 weeks.

- * Antifriction bearing grease, similar to Calypsol H 442 B, dripping point 185°C, ashes 0,7 to 1,2%.

EUGEN BAUER GMBH STUTTGART-UNTERTÜRKHEIM

Ⓢ E 11081N1A — 4 S 1 M26 - Printed in Germany - Änderungen vorbehalten