

# Film-Tech

The information contained in this Adobe Acrobat pdf file is provided at your own risk and good judgment.

These manuals are designed to facilitate the exchange of information related to cinema projection and film handling, with no warranties nor obligations from the authors, for qualified field service engineers.

If you are not a qualified technician, please make no adjustments to anything you may read about in these Adobe manual downloads.

[www.film-tech.com](http://www.film-tech.com)



# **XD10 Cinema Media Player**

## **Installation and Operating Guide**

**Version 1.0**

**Effective Date: June, 2003  
Document # 9301E692001.0**

**Digital Theater Systems, Inc.  
Cinema Products Division  
5171 Clareton Drive  
Agoura Hills, CA 91301  
USA**



## Table Of Contents

XD10 Cinema Media Player .....	i
Introduction .....	vii
DTS Customer Service .....	viii
Returning Units for Service .....	ix
Installation Checklist .....	x
<b>1. OPERATIONAL OVERVIEW .....</b>	<b>1-1</b>
1.1. Loading Discs .....	1-1
1.1.1. Contents File Management .....	1-1
1.1.2. About DTS Movie Discs .....	1-1
1.1.3. About DTS Trailer Discs .....	1-2
1.2. Basic Operation .....	1-2
1.2.1. Loading a Disc (General) .....	1-2
1.2.2. Loading a 2-disc Movie .....	1-3
1.2.3. Loading a 1-disc movie .....	1-3
1.2.4. Loading a 3-disc movie .....	1-3
1.2.5. CD-ROM Read Error .....	1-4
1.2.6. Splice in the DTS Logo Trailer Film .....	1-4
1.2.7. Running a Show .....	1-4
1.2.8. Changeover .....	1-4
1.2.9. Film Breaks and Edits .....	1-4
1.3. Routine Maintenance .....	1-5
1.4. After the Show .....	1-5
1.5. Controls and Indicators .....	1-6
1.5.1. Front Panel Controls and Indicators .....	1-6
1.5.2. LCD Playscreen .....	1-6
1.6. Menus .....	1-7
1.7. Playback .....	1-10
1.7.1. Soundtrack .....	1-10
1.7.2. Video .....	1-11
1.7.2.1. Play Menu .....	1-11
1.7.2.2. Status Menu .....	1-11
1.7.2.3. Control Menu .....	1-12
1.7.2.4. Video Logging .....	1-12
1.7.3. CSP Language .....	1-13
1.7.4. Contents .....	1-14
1.7.5. CSP Lamp Status .....	1-14
1.8. System Setup .....	1-15
1.8.1. TC Reader Offset .....	1-15
1.8.2. Audio Setup .....	1-16
1.8.2.1. Level Adjustment .....	1-16
1.8.2.2. Language Versions .....	1-16
1.8.2.3. Audio Tests .....	1-17
1.8.3. Video Setup .....	1-18
1.8.3.1. Set Image .....	1-18
1.8.3.2. Set Player Zone .....	1-19
1.8.3.3. Set AutoStop .....	1-19
1.8.3.4. Set Application .....	1-19
1.8.3.5. Set Test/Normal .....	1-20
1.8.3.6. Factory Settings .....	1-20



1.8.4.	CSP Setup .....	1-21
1.8.4.1.	Image Size .....	1-21
1.8.4.2.	Vertical Offset .....	1-21
1.8.4.3.	Test Patterns .....	1-21
1.8.4.4.	Options .....	1-22
1.8.5.	Automation Setup .....	1-23
1.8.5.1.	Format Assignment .....	1-23
1.8.5.2.	Operating Modes .....	1-26
1.8.5.3.	I/O Control.....	1-27
1.8.5.4.	Automation Test .....	1-29
1.8.6.	System Options .....	1-30
1.8.6.1.	COM2 Configuration.....	1-30
1.8.6.2.	Set Password.....	1-30
1.8.6.3.	Network.....	1-31
1.8.6.4.	System Clock.....	1-31
1.8.7.	Display Language.....	1-32
1.9.	Info.....	1-32
1.9.1.	Version.....	1-32
1.9.2.	MAC Address .....	1-32
1.10.	Language Management for the XD10.....	1-33
1.10.1.	Trailer Considerations.....	1-33
1.10.2.	Language Versions Enable.....	1-33
1.10.3.	Language Versions Selection.....	1-33
1.10.4.	Using Automated Language Setups .....	1-34
1.11.	Check Procedures.....	1-36
1.12.	Compatibility with Existing Discs .....	1-37
<b>2.</b>	<b>INSTALLATION .....</b>	<b>2-1</b>
2.1.	Unpacking and Inspection.....	2-1
2.2.	System Components.....	2-2
2.3.	XD10 Interconnection to Cinema Processors .....	2-3
2.3.1.	DTS XD10 Interaction with Other Cinema Processors .....	2-4
2.3.1.1.	Dolby CP200 Operation .....	2-4
2.3.1.2.	Dolby CP45, CP55, CP65, CP500, CP650, UltraStereo JS Series, and SMART Operation .....	2-4
2.3.1.3.	Dolby DA10 / 20 SR-D™ System .....	2-4
2.3.1.4.	Sony SDDS™.....	2-4
2.4.	Installation Procedures.....	2-6
2.4.1.	Preliminary Inspection .....	2-6
2.4.2.	Timecode Reader Head Installation.....	2-6
2.4.2.1.	Two projector (change-over) theaters.....	2-6
2.4.3.	DTS XD10 Player Installation .....	2-6
2.4.3.1.	Rack Mounting and Connection .....	2-6
2.4.3.2.	Rack Mount Considerations .....	2-7
2.5.	XD10 Connectors.....	2-8
2.6.	Options List.....	2-4
2.7.	Options Setup and Testing .....	2-11
<b>3.</b>	<b>CALIBRATION AND SETUP .....</b>	<b>3-1</b>
3.1.	Equipment Requirements.....	3-1
3.2.	Measuring and Adjusting XD10 Audio Levels.....	3-1
3.2.1.	Verifying Audio Levels .....	3-1
3.2.2.	A Note about DTS Subwoofer Output.....	3-3
3.2.3.	Mono Surround .....	3-3



3.3.	Timecode Reader Sync Adjustment.....	3-3
3.4.	Verifying Operation.....	3-4
3.4.1.	Verify Sound Performance.....	3-4
3.4.2.	Check Automatic Fail-Safe (Default) Operation .....	3-5
<b>4.</b>	<b>SPECIFICATIONS.....</b>	<b>4-1</b>
4.1.	Inputs.....	4-1
4.2.	Audio Outputs.....	4-1
4.3.	Other Connectors .....	4-2
4.4.	DVD ROM Drives .....	4-3
4.5.	Hard Drive .....	4-3
4.6.	User Interface.....	4-4
4.6.1.	Status LEDS (Front Panel).....	4-4
4.7.	Regulatory – Safety, Emissions, and Susceptibility Specifications.....	4-5
4.8.	XD10 Block Diagrams.....	4-6
<b>5.</b>	<b>XD10 MAINTENANCE AND TROUBLESHOOTING.....</b>	<b>5-1</b>
5.1.	Routine Maintenance .....	5-1
5.2.	XD10 Troubleshooting Tips .....	5-1
5.2.1.	I have a DTS print but I don't have discs.....	5-1
5.2.2.	Film not in sync or doesn't sound right .....	5-2
5.2.3.	Volume too loud.....	5-2
5.2.4.	DTS-XD10 won't switch into digital sound .....	5-2
5.2.5.	DTS XD10 switches out of DTS Digital.....	5-2
5.2.6.	What do I do with the discs when the movie has finished its run? .....	5-2
5.3.	Guide For A Seamless Change-Over.....	5-3
5.3.1.	Sound changes before picture .....	5-3
5.3.2.	Picture changes before sound.....	5-3
5.3.3.	Determining roll-down.....	5-3
5.4.	Inside the DTS XD10.....	5-4
5.4.1.	Timecode Board.....	5-4
5.4.2.	Power Supply .....	5-4
5.4.3.	DVD/CD-ROM Drives .....	5-4
<b>A.</b>	<b>DTS XD10 SYSTEM PARTS LIST.....</b>	<b>A-1</b>
A.1.	XD10 Master Parts List .....	A-1
A.2.	Replacement Parts.....	A-2
<b>B.</b>	<b>INSTALLATION DIAGRAMS.....</b>	<b>B-1</b>
B.1.	Interconnect Diagrams: XD10 to Cinema Processor .....	B-1
	<b>Drawings:</b>	
	D435 Timecode Cable	
	E680 (XD10 to CP45 Audio)	
	E681 (automation- DTS-6D translation)	
	E682B (XD10 to CP650-500-65)	
	E683A (XD10 TO CP650-500 AUDIO)	
	E684 (XD10 TO CP65 SRD audio)	
	E694A (XD10-CP650)	
	E699A (XD10-CP500)	
	E700 (XD10-CP65)	
	E701 (XD10-65-SA)	
	E706 (XD-10 to Ultra Stereo)	
	E709 (XD10 to Smart VI)	
	E720 (XD10 TO DFP-D3000 AUDIO)	



E721A (XD10 TO DFP-D3000 AUTOMATION)  
E722 (XD10-DFPD3000)  
E724 (XD10 to CSP1200)  
E726 (XD10-6AD)  
E727(XD10-CSP1200)  
E728 (XD10-CP45)  
E730 (XD10-SMART VIVII)  
E732 (XD10-CP200)  
E733 (XD10-CP200SRD)  
E734 (XD10-CP55 MONO)  
E735 (XD10-CP55 STEREO)  
E742 (XD10-CP200)

B.2. Brackets for the DTS Timecode Reader Head, 35mm and 70mm..... B-2  
B.3. Timecode Reader Head Aux Roller Installation ..... B-11  
B.4. Timecode Reader Head Drawings ..... B-12  
B.5. DTS 35mm and 70mm Readers, Switchable, Using the Same Bracket..... B-13

**C. XD10 MENU STRUCTURE ..... C-1**

**D. LANGUAGE MANAGEMENT ..... D-1**

D.1. Soundtrack Dubbed Languages ..... D-1  
D.2. File Header (Header.exe) ..... D-2  
D.2.1. XD10 Operation ..... D-2  
D.2.2. Trailers ..... D-2  
D.3. Subtitle Languages..... D-3

**E. DTS TRACK SPECIFICATIONS ..... E-1**

**F. VIDEO OPTION INSTALLATION ..... F-1**

F.1. XD10 Video Option..... F-1  
F.1.1. Field Installation for Type 1 Video Card ..... F-1  
F.1.1.1. Hardware Installation Procedure..... F-1  
F.1.2. Enable / Test Procedure ..... F-3  
F.1.3. Debug Procedure ..... F-3  
F.1.4. Configuration Procedure ..... F-3  
F.1.4.1. Restore Factory Defaults..... F-4

**G. CINEMA SUBTITLING SYSTEM (CSS) OPTION..... G-1**

G.1. DTS-CSP Subtitle Projector..... G-1  
G.1.1. Projector Air Space Requirements ..... G-1  
G.2. DTS-EMA Mounting ..... G-1  
G.3. DTS-EMA Assembly ..... G-3  
G.4. DTS-EMA Vertical Drop Mounting Guide ..... G-5  
G.5. Subtitle Projector Installation..... G-8  
G.5.1. Installation Tools ..... G-8  
G.5.2. Installation Procedure ..... G-8  
G.5.3. Programming the DTS-CSP Subtitle Projector..... G-13  
G.5.4. Position the DTS-EMA Mask Trims (with screen masking added)..... G-16  
G.5.4.1. Vertical Subtitles..... G-16  
G.5.4.2. Horizontal Subtitles..... G-16  
G.6. Regular Maintenance of the DTS-CSP System ..... G-17  
G.6.1. Routine Projector Lamp Maintenance ..... G-17  
G.6.2. Lamp Module Dust Filter Screen ..... G-17  
G.6.3. Projector Lens Cleaning..... G-17  
G.7. Replacing the Lamp Module..... G-18



G.7.1. Reset the Lamp Hour Counter on the Projector ..... G-20

G.8. DTS-EMA Maintenance ..... G-21

G.9. Troubleshooting the DTS-CSS Option ..... G-22

G.10. Troubleshooting Rear Window (Captions) Option ..... G-24

G.11. Troubleshooting Narration Option ..... G-24

G.12. Testing Subtitles ..... G-25

G.13. Testing Narration ..... G-25

G.14. Testing Rear Window Captions ..... G-26

**H. TECHNICAL NOTES..... H-1**

- TN-E538 Cleaning the CSP Lamp Module Dust Filter
- TN-E550A Timecode Reader LED Calibration

**WARRANTY**

**DTS MARQUEE SIGN ORDER FORM**



## **Introduction**

The DTS XD10, Cinema Media Player is designed to deliver 10 channels of scalable digital surround sound, high quality video for alternate media, and to support access options such as projected subtitles, Rear Window™ captioning, and a descriptive audio narration. The XD10 is an expandable, reliable and user-friendly media solution for pre-show and feature film presentation. The XD10 is also compatible with both traditional film playback and digital cinema.

It is a dual system with reference to film sound in that the digital audio data is recorded on DVD/CD-ROM discs and then loaded onto the hard drive. Proprietary DTS timecode, that is used to synchronize the sound and picture, is printed onto the release print from the soundtrack negative. The DTS timecode is printed between the picture and the optical sound track.

The DTS XD10 provides the standard 5.1 channel outputs: Left, Center, Right, Left Surround, Right Surround, and Subwoofer (L, C, R, LS, RS, SW). In addition, the XD10 can provide Left Center, Right Center, Back Surround, and Auxiliary outputs for select releases. A Mono Surround output, derived from mixing the LS and RS outputs, is also available.

The system allows for storage of up to 30 complete film sound tracks loaded on its hard drive at any one time. Once the film sound information is loaded, no further action is needed from the projectionist. The system automatically starts; stops, and tracks film breaks and changeovers. Cinema Subtitling System (CSS) interface capability can be added easily with additional licensing, and two options are available to expand the system functionality to include either a video board or a second expansion board for additional audio channels. There is also an option for AES/EBU digital output board that can be configured two ways.

DTS encoded material is available in two formats: standard and Coherent Acoustics. Material recorded in standard digital audio at a 44.1K sample rate with digital audio data compression (4:1) provides 8 audio channels plus 2 auxiliary channels. Material recorded with Coherent Acoustics encoding is scalable, and allows for lossless compression if desired, as well as 96/24. Coherent Acoustics provides for 10 audio channels, plus 2 auxiliary channels. The auxiliary channels will not be phase coherent with the main output channels. The audio used in conjunction with the video will be Coherent Acoustics PCM 48/24 and will be compatible to standard DVD recordings. Note that the XD10 will NOT play consumer type DVDs.

Containing an internal hard drive capable of storing up to 30 feature film soundtracks, the XD10 offers the flexibility of storing multiple languages of one title or multiple titles. The product is also capable of playing back enhanced video for alternate media, and has networking and pre-show programming features for an integrated presentation.

For reliability, the XD10's internal hard drive is used as the film sound signal source. Two DVD drives are provided to download film sound information to the hard drive. When discs are loaded into the player, the system downloads the first reel (in approximately 30 seconds), and then begins to play the film. The balance of the reels is recorded onto the XD10 hard drive while the first reel is being played.

The downloading process needs to be performed only one time; after that, playback is automatic. XD10 will automatically load and store up to 30 full-length films. Subsequent loading is accommodated by sequential replacement of previously loaded films.

DTS timecode assures not only accurate sound and picture synchronization, but is keyed to assure films are run with the correct audio tracks. 35mm films released in the DTS digital sound format also contain a traditional analog (optical) sound track (SR, A-TYPE, or MONO) to serve as a back-up sound source. To further ensure fail-safe operation, XD10 will perform automatic error detection. If problems are detected with the digital sound, the system automatically switches to the proper analog sound format.





This and other unique features are detailed in the following pages. To get the most out of the XD10 system, we suggest that you review this material, and keep it available during system installation and initial operation.

To let your audience know that your theater is equipped with DTS technology, we have made the following promotional materials available. Call DTS Customer Service for price and ordering information.

DTS marquee signs (See order form at the back of this manual.)

DTS one sheets

DTS logo films, available in scope and flat

DTS buttons and pins

We also publish the *Tech Talk* newsletter with tips and updates for our users. *Tech Talk* is published quarterly – and posted on our web site. If you would like to be added to our mailing list, contact DTS Customer Service.

## **DTS Customer Service**

DTS engineers are available to assist you. If you have an emergency after business hours, please leave a message with the Answering Service and a technician will return your call as soon as possible.

### **DTS Headquarters**

**5171 Clareton Drive  
Agoura Hills, CA 91301**

**Email: [cinematech@dtsonline.com](mailto:cinematech@dtsonline.com)  
Phone: +1 (818) 706.3525 or in USA +1 (800) 959.4109  
Customer Service Fax +1 (818) 879.2746**

### **DTS Europe**

**Email: [dtsinfo@dtsonline.co.uk](mailto:dtsinfo@dtsonline.co.uk)  
Phone: +44 (0) 1189.349.199  
Fax: +44 (0) 1189.349.198**

### **DTS Japan**

**Email: [nohtake@dtsonline.co.jp](mailto:nohtake@dtsonline.co.jp)  
Phone: +81 (0) 3.5564.7157  
Fax: +81 (0) 3.3520.1022**

Visit our web site <http://www.dtsonline.com> for the latest DTS news on both theater and home products.



## **Returning Units for Service**

Before sending any item back to DTS for warranty, repair, exchange or replacement parts, please call DTS at (818) 706-3525 or USA toll free (800) 959-4109 to provide the serial number of the equipment to be returned and to obtain a **Return Authorization** number. No replacement units will be sent and no shipments will be accepted without a Return Authorization number.

Ship returns (clearly marked with the Return Authorization number on the outside of the package) to:

**Digital Theater Systems**

**Attn: Customer Service**

**5171 Clareton Drive**

**Agoura Hills, California 91301 USA**

Telephone and FAX numbers are listed above under DTS Customer Service.



## Installation Checklist

Use these checklists to ensure important settings are completed before showing film to an audience. The first one is for the XD10. The second list is for the CSS Option. The third one is for the Video option.

Table 0-1. XD10 Installation and Setup

Completed	Task	Refer to:
<input type="checkbox"/>	Install XD10 in equipment rack	Ch. 2, p. 2-5
<input type="checkbox"/>	Install Timecode Reader Head onto projector(s)	Ch. 2, p. 2-5 (see also diagrams in Appendix B)
<b>CONNECT CABLING:</b>		
<input type="checkbox"/>	Power cable	
<input type="checkbox"/>	Timecode Reader Head interconnect cable to XD10 Timecode connector	
<input type="checkbox"/>	Cable from XD10 Automation to Cinema Processor	Appendix B interconnect diagrams
<input type="checkbox"/>	Audio (analog output) cable from XD10 Analog Out to Cinema Processor	Appendix B interconnect diagrams
<b>PROGRAMMING STEPS</b>		
<input type="checkbox"/>	Automation Setup: Pin Definitions, Fallback Formats, and Operating Modes	Ch. 1 System Setup   Automation Setup   Format menu, p. 1-22
<input type="checkbox"/>	(optional) I/O Control: Pin Definitions and Language Setups	Ch. 1 System Setup   Automation Setup   I/O Control menu, p. 1-26
<input type="checkbox"/>	Automation Test	Ch. 1 System Setup   Automation Setup   Automation Test, p. 1-28
<input type="checkbox"/>	Language Versions: Enable?	Ch. 1, topic Language Versions Enable, p. 1-32; Ch. 1 System Setup   Audio Setup menu, p. 1-14
<input type="checkbox"/>	Use Automated Language Setups?	Ch. 1, topic Automated Language Setups, p. 1-33
<input type="checkbox"/>	Select Language Version?	Ch. 1, topic Language Versions Selection, p. 1-33
<input type="checkbox"/>	COM 2 Configuration: set to EMA Port for CSP video control or set to IR Port for downloading video log files	Ch. 1 System Setup   System Options   COM2 Configuration, p. 1-29; REBOOT after changing this setting
<input type="checkbox"/>	Enable/disable Network communication	Ch. 1 System Setup   System Options   Network menu, p. 1-29
<input type="checkbox"/>	Set System Clock: set time zone, date and time; View the current setting	Ch. 1 System Setup   System Options   System Clock menu, p. 1-29
<input type="checkbox"/>	Set Password to prevent unauthorized access to XD10 settings	Ch. 1 System Setup   System Options   Set Password, p. 1-29
<input type="checkbox"/>	Check Features / Trailers are loaded	Ch. 1, topic Check Procedures, p. 1-35 Ch. 1, Playback   Contents menu, p. 1-12
<b>ADJUST AND TEST</b>		
<input type="checkbox"/>	Set and adjust XD10 sound levels	Ch. 3, topic Measuring and Adjusting XD10 Levels p. 3-1; Ch. 1 System Setup   Audio Setup   Level Adjustment, p. 1-14
<input type="checkbox"/>	Timecode Reader Sync Adjustment	Ch. 3, topic Timecode Reader Sync Adjustment, p. 3-3; Ch. 1, Setup   TC RDR Offset menu, p. 1-13
<input type="checkbox"/>	Verify Sound Performance	Ch. 3, topic Verify Sound Performance, p. 3-4
<input type="checkbox"/>	Perform Audio Tests	Ch. 1 System Setup   Audio Setup   Audio Tests, p. 1-15
<input type="checkbox"/>	Load cinema feature / trailer disc(s)	Ch. 1, topic Loading a Disc, p. 1-2
<input type="checkbox"/>	Check Automatic Fail-Safe (Default) Operation	Ch. 3, topic Check Automatic Fail-Safe (Default) Operation, p. 3-4



If **Cinema Subtitling System (CSS) option** is to be installed, complete the following steps.

Table 0-2. CSS Installation and Setup

Completed	Task	Refer to:
<input type="checkbox"/>	Install EMA and subtitling projector	Appendix G Cinema Subtitling System (option) Installation and Troubleshooting, p. G-8
<input type="checkbox"/>	Cable from EMA Control connector to EMA	
<input type="checkbox"/>	Cable from XD10 Projector Video connector to subtitling projector	
<input type="checkbox"/>	Program the subtitle projector	Appendix G, p. G-14; also see Ch. 1 System Setup   CSP Setup menu, p. 1-20
<input type="checkbox"/>	Position the EMA mask trims	Appendix G, p. G-17
<input type="checkbox"/>	Set CSP Language	Ch. 1, Playback   CSP Language menu, p. 1-12
<input type="checkbox"/>	Check CSP Lamp Status	Ch. 1, Playback   CSP Lamp Status menu, p. 1-13

If the **Video** option is to be installed, complete the following steps.

Table 0-3. Video Option Installation and Setup

Completed	Task	Refer to:
<input type="checkbox"/>	Install video card and cabling	Appendix F Video Option Installation, topic Field Installation, p. F-1
<input type="checkbox"/>	Install the license for Video Option (CD-ROM)	
<input type="checkbox"/>	Configure the video output	Appendix F, topic Configuration Procedure, p. F-3
<input type="checkbox"/>	Load video disc(s)	Ch. 1, topic Loading a Disc, p. 1-2
<input type="checkbox"/>	(optional) Reset Factory Settings	Ch. 1, System Setup   Video Setup   Factory Settings menu, p. 1-18
<input type="checkbox"/>	Set Resolution, Brightness, Contrast	Ch. 1, System Setup   Video Setup   Set Video menu, p. 1-17
<input type="checkbox"/>	Center the image and adjust width of image	Ch. 1, System Setup   Video Setup   Set Video menu, p. 1-18
<input type="checkbox"/>	(optional) Set Player Zone	Ch. 1, System Setup   Video Setup   Set Player Zone, p. 1-18
<input type="checkbox"/>	Set Autostop behavior	Ch. 1, System Setup   Video Setup   Set Autostop, p. 1-18
<input type="checkbox"/>	Adjust image to match your theater screen masking configuration	Ch. 1, System Setup   Video Setup   Set Application, p. 1-18
<input type="checkbox"/>	Play test images (Reset to Normal when complete)	Ch. 1, System Setup   Video Setup   Set Test/Normal, p. 1-18
<input type="checkbox"/>	View Playlist(s)	Ch. 1, Playback   Video   Play menu, Select Playlist, p. 1-10
<input type="checkbox"/>	Play a video segment and View Status	Ch. 1, Playback   Video   Play menu, select Play. Then select Status menu. p. 1-10.
<input type="checkbox"/>	Configure video play sequence	Ch. 1, Playback   Video   Control menu, p. 1-11
<input type="checkbox"/>	Set Video Logging parameters	Ch. 1, Playback   Video   Video Logging menu, p. 1-11 (If downloading video log files, see also Ch. 1 System Setup   System Options   COM2 Configuration, p. 1-29; REBOOT after changing this setting)

# 1. Operational Overview

This chapter includes instructions for loading DTS movie and trailer discs into the XD10 and discusses basic operation before, during, and after a show. The XD10 menu structure is described, and the various submenus and options are explained. Language Management, check procedures, and compatibility topics are covered near the end of this chapter.

## 1.1. Loading Discs

The XD10 contains two DVD/CD-ROM drives and a large capacity internal hard drive. Up to thirty full-length features can be stored on the hard drive. All titles (such as movie digital sound tracks) are played from the hard drive and titles are loaded to the hard drive from DTS cinema discs. DTS cinema discs are placed in the DVD/CD-ROM drives for transferring to the hard drive. Either drive A or B can be used to download DTS cinema titles. Once the XD10 is set up and the cinema discs are loaded, feature films, trailers, videos (if equipped with the Video Option), and subtitles/narration/captions (if equipped with the CSS Option) can be played directly from the XD10. The XD10 automatically starts, stops, and tracks film breaks and changeovers without needing any action from the projectionist/operator.

- Note:** The system uses caddy-less DVD/CD-ROM drives. The drive will not accept a DVD/CD-ROM disc in a caddy or case. You must remove the disc from its case and place it on the DVD/CD tray.

The DTS digital sound track will automatically download to the hard drive. Once the download is complete, a “Complete” message will display, prompting you to open the drive door to remove the disc and place it in its carrier. Place the carrier and disc back into the film can and return it to the film depot along with the print.

Load DTS cinema video discs as you would DTS cinema sound discs. Be aware that the disc must be labeled as a “DTS Cinema Video” disc. This disc has special formatting that enables the material to become part of the XD10 “Video Playlist”. It must be part of the Video Playlist in order for the material to be available for playback at the appropriate time.

### 1.1.1. Contents File Management

The hard drive capacity is 40 gigabytes. As additional material is loaded onto the hard drive, the drive may approach or reach its capacity for storage. In that case, loading new material will necessitate deletion of existing material, to make room. The XD10 file management approach is based on identifying existing material that has not been played recently.

The system keeps a list of data files. Whenever a show is played, or loaded from a disc, all material for that show is put at the head of the list. Therefore, files that have not played recently move down the list. The file that has not been played for the longest time is at the bottom of the list.

When a new CD-ROM is loaded, the program starts at the bottom of the list and deletes enough files to make room to copy the new material.

You can also use the PLAYBACK | CONTENTS menu to selectively delete features and trailers from the hard disc. (See page 1-14).

### 1.1.2. About DTS Movie Discs

DTS movie discs are issued to theaters from the film studio’s distribution company. Make sure the discs you are loading match the movie you want to play (for example, “Jurassic Park” film with “Jurassic Park” movie discs). Download one movie title at a time. Always return discs with the print.

- Note:** If film and discs do not match, the digital sound track will not play, when selected for playback on the Playlist.

Films that run 90 minutes or less require only one disc. These films, labeled “one disc only”, can be placed in either of XD10’s two drives.

 **Caution:** Do NOT insert any other disc into the second drive while loading a single-disc title.

Films running longer than 90 minutes will have two movie discs: one labeled **Track A** and another labeled **Track B**. These discs can be inserted into XD10’s two DVD drives in any order.

**Note:** On rare occasions, features may have a third disc. In this case, simply load the three discs one-at-a-time, ignoring messages about “missing” discs.

Any trailers added to DTS movie disc(s) will be listed on the front of each disc.

### 1.1.3. About DTS Trailer Discs

DTS trailer discs can be inserted into either of XD10’s two DVD drives. These discs are issued to theaters directly from DTS, with trailer titles listed on them.

**Note:** Trailers that are not listed on the front of the disc (even though encoded with DTS timecode) will play in analog only. To verify you have the latest trailer disc, contact DTS Post Production.

 **Caution:** Do NOT insert multiple trailer discs into the two DVD drives, nor insert a trailer disc in combination with any movie disc

**Note:** Use only DTS cinema feature and trailer discs. Music CDs and DVDs for home use will NOT work in the XD10 Player.

## 1.2. Basic Operation

### 1.2.1. Loading a Disc (General)

The XD10 uses DVD/CD-ROM drives (referred to herein as “DVD drives”). Remove the disc from its case and place it on the DVD/CD tray for loading to the hard drive. If there are two discs, they should be loaded at the same time using both DVD drives.

**Note:** Disc(s) can be loaded while a movie is playing. Loading will not interfere with playback.

1. Power on the unit (if it is not already ON). The Main power switch is on the rear of the unit (and should always be ON). The Standby / On switch is on the front of the XD10 – turn it ON.
2. Press the open/close button on either of the XD10’s DVD/CD drives to slide open the tray.
3. Remove any disc(s) that was previously left in the tray(s).
4. Remove the disc(s) you want to load from its case and place it on the tray. The disc must lay printed-side-up and lay flat in the tray.
5. To slide the tray back into the drive, press the open/close button or **gently** push the drawer inward.

The disc contents will now automatically download. When the download is complete, the LCD display will show “Complete”. Then press the **ENTER** button(s) to eject the tray(s).

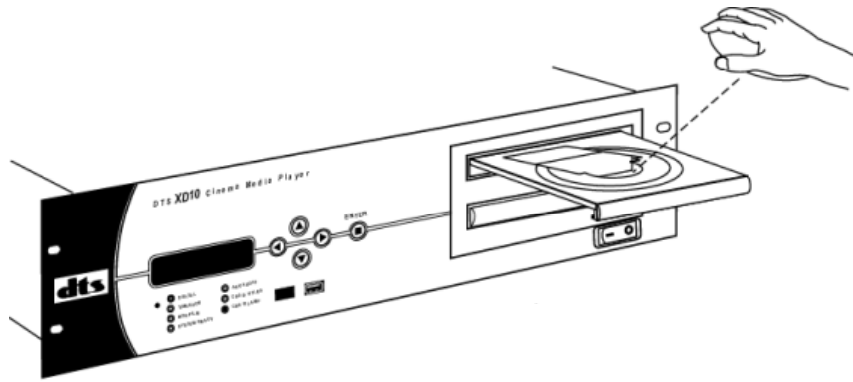

Figure 1. Loading a disc

6. Remove the disc from the tray and place it in its case. Put the case and disc back into the film carrier for return to the depot with the print.
  - DTS trailer discs may be stored. They do not need to be returned. When a new trailer is loaded (replacing the previous one), you may discard the old trailer disc(s).

### 1.2.2. Loading a 2-disc Movie

Movie soundtrack discs must be loaded as a set (if more than one disc movie). Insert both discs into the two DVD drives. If only one of two discs are loaded, then the following message appears:

**Warning: Second Disc  
May be Missing  
Insert Second Disc  
[Enter] - Ignore**

Press **ENTER** to **Ignore** the warning and continue loading. Otherwise, insert the second disc into the other disc drive, and the XD10 will clear the message and continue loading.

If the A and B discs are not from a matching set, then another error message appears. The problem could be any of the following:

- The two discs are from different movies.
- The two discs are the same movie but one is a different language.
- The two discs are both disc A (or both disc B).
- One of the discs is not a movie disc.

**ERROR:  
Installed Discs  
Are Not a Set  
[Left] Abort Load**

Press **◀** to **Abort** the loading process. Both drives will eject.

### 1.2.3. Loading a 1-disc movie

Place the disc into either drive. There is a slight chance that the player may ask for the second disc. If you are sure there is only one disc, then press **ENTER** to ignore the message and continue loading.

### 1.2.4. Loading a 3-disc movie

There are currently no provisions for loading a 3-disc movie. The sure way to make it work is to load one disc at a time and override the warning about “missing second disc”.

### 1.2.5. CD-ROM Read Error

If an error occurs reading a file, then only part of the file (or reel) will be copied. For trailers it would only be part of the trailer.

The following message is displayed:

```
Warning: Second Disc
CDROM Read Error
Some Audio Missing
[Enter] Continue
```

Press **ENTER** to **Continue** the loading process. Press **◀** to **Abort** the loading process. Both drives will eject.

If you press **ENTER** to accept the data, there will probably be some data missing, in which case the system will drop the DTS audio and switch to the optical audio source.

If you press **◀** to **Abort** the loading process, both drives will eject and the data that was already copied will be deleted from the hard disc.

- If your theater receives more than one copy of the film (with DTS CD-ROMs), you may solve this problem by substituting the faulty disc with a good disc from another copy.

### 1.2.6. Splice in the DTS Logo Trailer Film

Add the DTS trailer (logo) film to the head of the DTS encoded movie. Splice it in at about six frames after fade-out (where it should still have timecode) and add it directly to the first frame of the movie with timecode.

### 1.2.7. Running a Show

The Timecode Reader reads the serial number of the film and triggers the XD10 to play the soundtrack that matches that serial number. If Subtitling and/or Access options (Narration, Rear Window<sup>®</sup> Captioning) have been set up for this film, they will also begin to play automatically.

When the XD10 system is powered on and the display shows **READY**, the XD10 is ready for a show start.

- If the **READY** indicator does not display within 2 minutes, power off, wait three seconds, and power the unit on again. If the **READY** indicator still does not display within 2 minutes, power off the unit and contact DTS technical support.

When the film reaches the Timecode Reader head, the green light on the head will light and the XD10 front panel **Timecode** LED will turn on. A second later, the blue **DTS Playback** LED on the XD10 front panel will light and the DTS digital soundtrack will start playing.

### 1.2.8. Changeover

When two projectors are used, XD10 will automatically make a sound changeover when the first frame of the picture arrives at the aperture plate on the upcoming projector. DTS digital sound changes independently from the projector's douser position. Adjustment of the roll down on the upcoming projector may be necessary to keep the changeover "seamless". See the topic *Guide for a Seamless Changeover* in chapter 5, *XD10 Maintenance and Troubleshooting*.

### 1.2.9. Film Breaks and Edits

The XD10 will automatically track any length of edit. A 30 millisecond cross fade makes the edit transparent. After a film break, make sure the cinema processor is in DTS digital format.





### **1.3. Routine Maintenance**

Everyday – Use compressed air to blow off the Timecode Reader’s optics (lens) to remove dust.

Every 6 months (or as needed) – Using a DVD cleaning disc, the DVD drives should be cleaned.

Additional maintenance procedures, as well as troubleshooting advice, can be found in chapter 5 *XD10 Maintenance and Troubleshooting*.

### **1.4. After the Show**

#### **Feature discs**

After the feature has been loaded into the XD10, replace the discs into their cases and place back into the correct film cans.

#### **Trailer discs**

These are sent out by DTS and do not have to be returned after use.

## 1.5. Controls and Indicators

### 1.5.1. Front Panel Controls and Indicators

Refer to the component definitions below the figure.

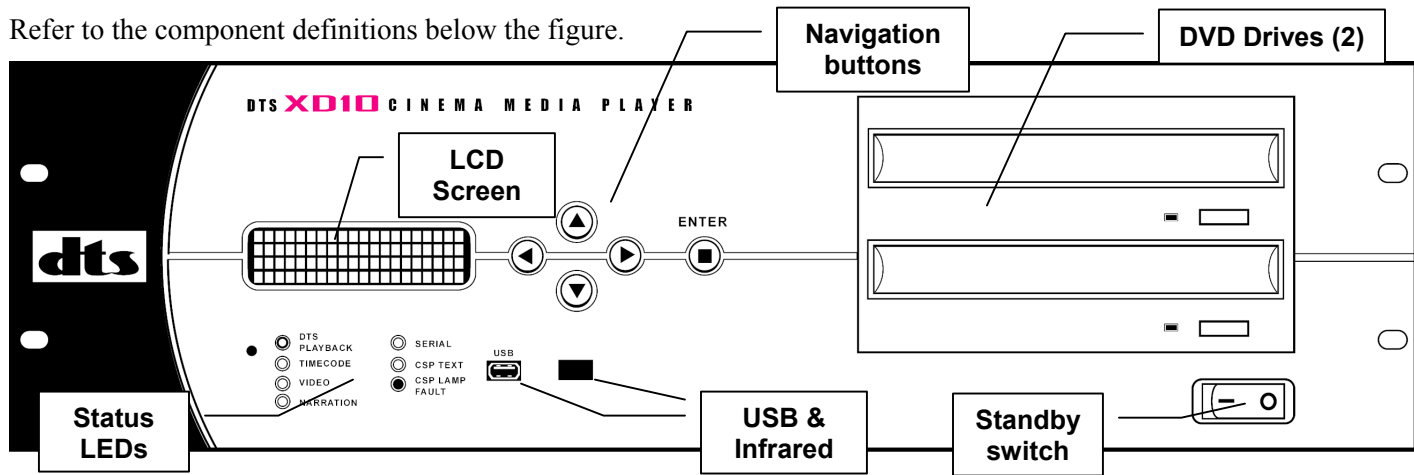

Figure 2. Front Panel Controls and Indicators

- LCD Screen – 4 lines of 20 alphanumeric characters display setup, configuration and operational parameters. While film is running, display indicates feature title, reel number, feature serial number, and timecode readout.
- DVD Drives – 2 DVD drives used for feature soundtrack loading
- Navigation – 5 navigational buttons enable menu selection and parameter adjustments within the LCD screen.
- Status LEDs – 7 LEDs provide status information during operation. (See table below.)
- Standby Switch -- Puts unit in and out of standby mode (the unit is OFF, but is still powered). (The Main Power switch is on the rear panel.)

Table 1. Front Panel LED Indicators

LED	Color	Indication
DTS PLAYBACK	Blue	Outgoing signal / digital signal
TIMECODE	Green	Incoming Timecode data
VIDEO	Green	Transmitting Intermission program, or other audio/video material
NARRATION	Green	Outputting narration
SERIAL	Green	Serial data output / Rear Window captions
CSP TEXT	Green	CSS subtitles
CSP LAMP FAULT	Red	If flashing, replace CSS projector lamp. Solid light indicates lamp failure.

### 1.5.2. LCD Playscreen

In addition to the front panel status LEDs, the XD10 liquid crystal display (LCD) screen shows useful information during playback. This information includes identifying data for the program material being played, as well as running timecode. It can also display additional information as described below.

If no program material is running, the display will simply show **READY** to indicate that it is on. When content is running, a typical LCD screen will look like this example:



Figure 3. Playscreen Display (typical)

The first three lines of the display show the film title (or trailer name), identifying Serial Number, and the Reel number that is currently playing, along with running timecode. This information will appear continuously during playback. **You can choose what information the fourth line will display by pressing the Up and Down buttons:**

- No selection – Bottom line will be blank and show nothing
- Fmt: – the current format of the Cinema Processor (DTS or Optical) – this may not be available with all processors
- CSP LANG: – the language the Cinema Subtitling Projector is using
- End of reel: – the total time of the reel currently playing (this does not change until the next reel starts)

## 1.6. Menus

The XD10 menus are divided into two major areas of control, one for System Setup, the other for Playback functions. Status displays showing System Version and other information are also available from the Main Menu. The diagram on the next page shows how to use navigation buttons with the menu structure to perform a typical adjustment.

## Using the Menus

If no program material is running, the display will simply show **Ready** to indicate that it is on.

Ready

Press the **Enter** button.

MAIN MENU  
⇒ Playback  
• Setup  
• Info

Press **▼** once and then **Enter** or **▶**.

SETUP MENU  
⇒ TC Reader Offset  
• Setup  
• Video

Press **Enter** or **▶**.

**Use ▲ to scroll upward and to increment parameters**

**Use ▼ to scroll downward and to decrement parameters.**

**Use ◀ to back through menus**

**Use ▶ to enter submenus**

**Press ENTER to confirm action**

Set Timecode Reader  
Offset:

[ 30.00 ] Frames

Adjust with **▲** and **▼**.  
Press **Enter** or **◀** to accept.

SETUP MENU  
⇒ TC Reader Offset  
• Setup  
• Video

To Exit, press **▼** repeatedly to get to the end of this menu.  
Or press **◀** to go back through the previous screen(s).

• Automation Setup  
• System Options  
• Display Language  
⇒ Exit Menu

Press **Enter** or **▶** to Exit Menus.

Ready

You're back at the beginning.

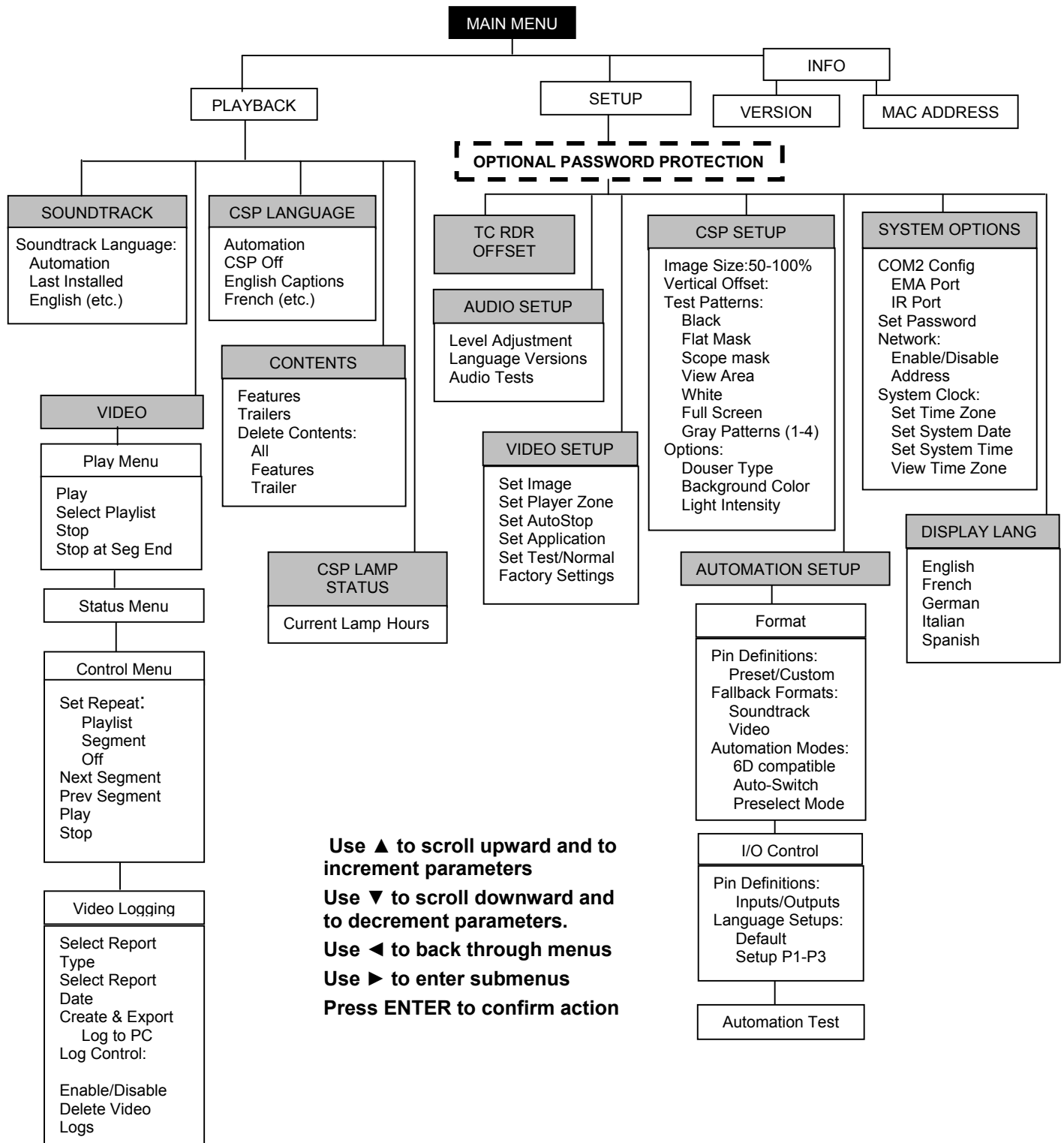

## 1.7. Playback

The XD10 Playback menu contains all of the controls and status reporting which might be needed during system operation. Many XD-10 functions are automated and programmed during system installation. The Playback Menu is intended for the projectionist/operator and is not password protected.

If your system has the CSS Option installed, you will be able to select the subtitling language in the Playback menu. If the Video Option is installed, you will find controls here for manual operation, as well as status and reporting.

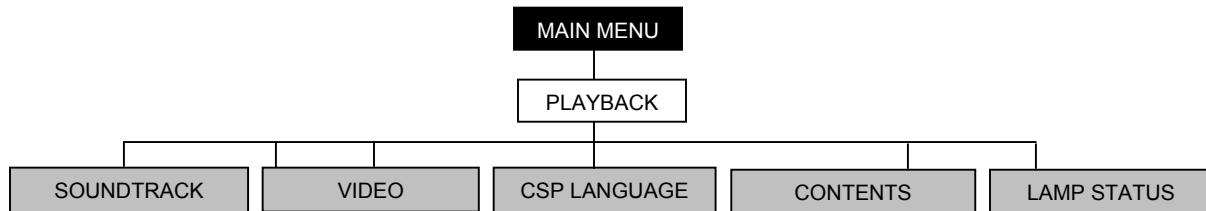

### 1.7.1. Soundtrack

The Soundtrack menu allows you to specify whether the soundtrack language is to be determined by Automation settings, or whether it should run in the language last used, or another available language. This control enables variations to be made without altering the Automation schedule.

- To enable this control, go to System Setup | Audio Setup | Language Versions and select “Enabled”.
- When a language is selected, be sure that the soundtrack for that language has been loaded into the XD10. If you choose a language that has not been loaded, it will not play.

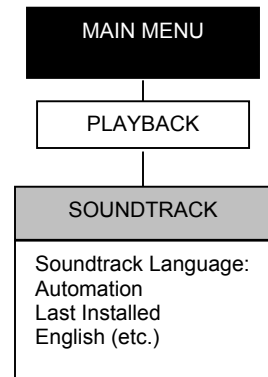

## 1.7.2. Video

Your XD10 player must be equipped with the Video Option for the Video menu to appear. This menu contains the Video playlist and status information, access to manual control over your video projector (different from the DTS-CSP projector used for subtitles/captions), and a variety of logging and reporting options. If your system is not equipped with the Video Option, all of these menu selections, as well as the Video Setup menu, will be inaccessible. In that case, the system will display the message: “Video feature is not enabled. License required.”

### 1.7.2.1. Play Menu

Standard commands for **Play**, **Stop** and **Stop at Segment End** (the end of the currently running segment) are located in this menu. After selecting one of these, press **ENTER** to activate.

- Note:** If you select “Stop” or “Stop at Seg End”, and then select “Play”, the video title will restart playing from the beginning.

The **Select Playlist** option allows you to select playlist entries that have been loaded to the hard drive. Move the cursor to highlight **Select Playlist**, then press **ENTER**. A submenu will display, showing the available playlists to choose from. This is an example:

```
Select Playlist
( ) LONG_LIST
( ) 1_3_LIST
( ) etc.
```

Select one and press **ENTER**.

- Note:** The playlist options shown are the only ones available for playback on the XD10 hard drive.

### 1.7.2.2. Status Menu

Select this menu item to view the currently selected Video Play settings. The status reported here reflects selections made in both the Video Control and Setup menus.

```
PL: ALL
Seg: Behind Enemy Lines
Seg: 01 of 07
Rpt: Segment
Playlist Zone: 00
Player Zone: 00
Audio Type: DTS
```

Definitions:

- PL – Playlist ID, this is the name of the Playlist that was loaded from the DVD
- Seg – the name of the currently running segment
- Seg – the sequence of the currently running segment; in this example, it’s the first of seven
- Rpt – (Repeat) in this example, the current segment will repeat (see *Set Repeat*, next page under *Control Menu*)
- Playlist Zone – the zone code of the current Playlist
- Player Zone – the zone code for this XD10 player, as set in *Set Player Zone*, page 1-19
- Audio Type – in this example, DTS

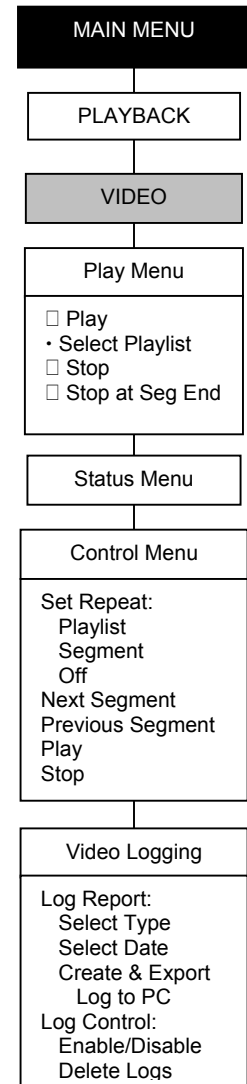

### 1.7.2.3. Control Menu

The Control menu allows you to start playing the next segment of the current video playlist, to repeat the previous segment, or to set the XD10 to continuously play either the current segment or the complete playlist.

```
CONTROL MENU
• Set Repeat
 Next Seg
 Prev Seg
 Play
 Stop
```

Use ▲ and ▼ to move the cursor, then press ENTER.

If **Set Repeat** is selected, a submenu will display (shown below).

```
Repeat Menu
( ) Playlist
( ) Segment
( ) Off
```

Use ▲ and ▼ to move the cursor, then press **ENTER** to activate.

#### Set Repeat

- Segment – will repeat the current segment continuously
- Playlist – will repeat the whole Playlist continuously
- Off – will not repeat
- Note:** If Repeat is set, then whenever a Stop command is received the next Play instruction will cause Video to restart from the beginning of the current segment and continue in repeat mode until **Repeat: Off** is selected. For convenience, Play and Stop controls are provided in this menu as well.

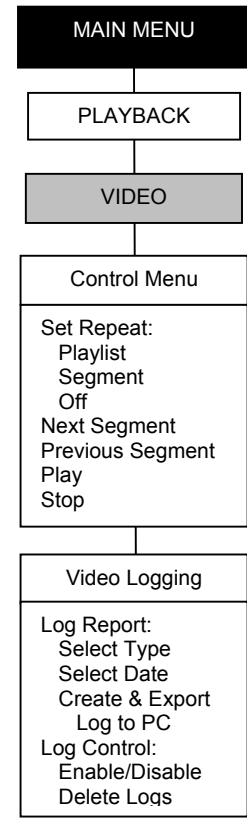

### 1.7.2.4. Video Logging

If Video Logging is enabled, the XD10 will track up to a month of video play data and allow you to send reports to a PC to satisfy a variety of reporting requirements. You can select to compile logs based on content, playlist, or both, and choose reporting periods that range from daily activity reports to reviews as far back as a month.

```
VIDEO LOG MAIN MENU
Log Report Menu
Log Control Menu
```

Use ▲ and ▼ to move the cursor, then use ► to open submenu.

Select **Log Report Menu** and a submenu similar to this example will display.

```
Select Report Type
Select Report Date
Create and Export
```

Use ▲ and ▼ to move the cursor, then use ► to open submenu.

Choose **Select Report Type** and a submenu similar to this example will display.

```
Report Type
( ) Content
( ) Playlist
( ) Both
```

Use ▲ and ▼ to move the cursor, then press **ENTER** to activate.

Choose **Select Report Date** and a submenu similar to this example will display.



```

Report Period
( ) Today
( ) Yesterday
( ) Past 7 days
( ) Past 14 days
( ) Past 30 days
( ) Current month
( ) Previous month

```

Use ▲ and ▼ to move the cursor, then press **ENTER** to activate.

Choose **Create and Export** and a submenu similar to this example will display.

```

PC Ready to Receive
Log Report via IrDA?
[ Yes (Send) ]
[ No (Cancel) ]

```

Use ▲ and ▼ to toggle between Yes and No, then press **ENTER** to activate.

Select **Log Control Menu** and a submenu similar to this example will display.

```

VIDEO LOG CTRL MENU
Disable Logging
Delete Video Logs

```

Use ▲ and ▼ to move the cursor, then use ► to open submenu.

Choose **Disable Logging** and a submenu similar to this example will display.

```

Enable/Disable Log
( ) Disable Logging
( ) Enable Logging

```

Use ▲ and ▼ to move the cursor, then press **ENTER** to activate.

Choose **Delete Video Logs** and a submenu similar to this example will display.

```

Delete All Video Logs?
( ) No (Cancel)
( ) Yes (Delete)

```

Use ▲ and ▼ to move the cursor, then press **ENTER** to activate.

### 1.7.3. CSP Language

If your XD10 is equipped with the CSS Option, this menu will allow you to select any of the issued subtitle languages for projection, to have the language specified by Automation controls, or to specify that no subtitling be shown. If the CSS Option is not installed, **CSP Off** will be pre-selected and the other options will be unavailable.

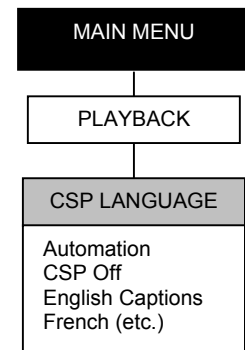

### 1.7.4. Contents

The Contents Menu allows you to view the list of all currently loaded features and trailers and to selectively delete any or all of them. See *Check Procedures* on page 1-36 for an example. They are listed in the order they were loaded onto the hard disc.

- ☑ See *Contents File Management*, on page 1-1 for a description of the process by which older files are deleted from the hard disc when space for new files is required.

Select **Features** or **Trailers** to view a list of currently loaded files.

Select **Delete Contents** to manually delete features or trailers from the hard drive. (The system will automatically delete the files that have not been played for the longest time, when new material is loaded that requires additional space on the hard drive. See *Contents File Management* on page 1-1.) The Delete Contents menu looks like this:

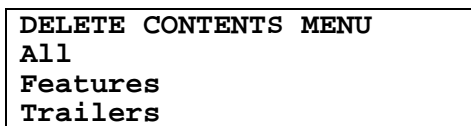
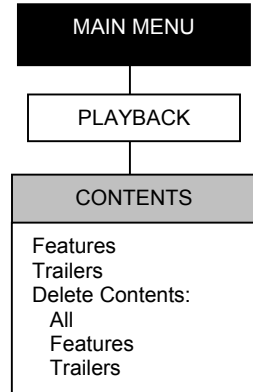

Use ▲ and ▼ to move the cursor, then use ► to open submenu.

If **All** is selected:

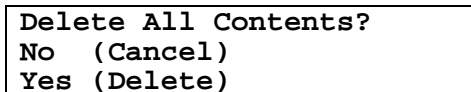

Use ▲ and ▼ to move the cursor, then use ► or ENTER to select.

If **No** is selected, a message will inform you that the delete action has been aborted.

If **Yes** is selected, a message will inform you that all contents have been deleted.

If **Features** is selected:

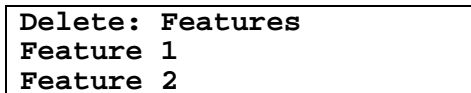

Use ▲ and ▼ to move the cursor, then use ► or ENTER to select.

If **Trailers** is selected:

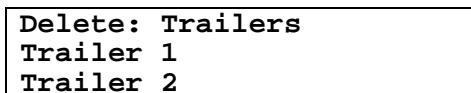

Use ▲ and ▼ to move the cursor, then use ► or ENTER to select.

### 1.7.5. CSP Lamp Status

If the XD10 is equipped with the CSS Option, this menu displays the number of hours the DTS-CSP (cinema subtitle projector) lamp has been used (when the projector is powered up). The DTS-CSP lamp must be replaced after 1400 hours of use. The front panel “CSP Lamp Fault” LED will light solid when the lamp hours has reached 1400 and will blink if the DTS-CSP lamp has burned out.

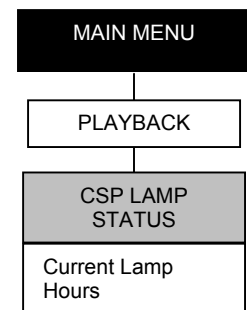

## 1.8. System Setup

The XD10 Setup menu contains all of the controls needed to configure the unit for installation, operation, automation, and test. This section of the menu also provides controls for setup and configuration of the CSS and Video Options.

- ☑ **Note:** You can restrict access to this entire menu section by setting a 3-digit password under **System Options**. When a password has been assigned, selecting **Setup** from the Main Menu will trigger display of a Password Request screen, and will not display any of the **Setup** menus until the assigned Password is entered.

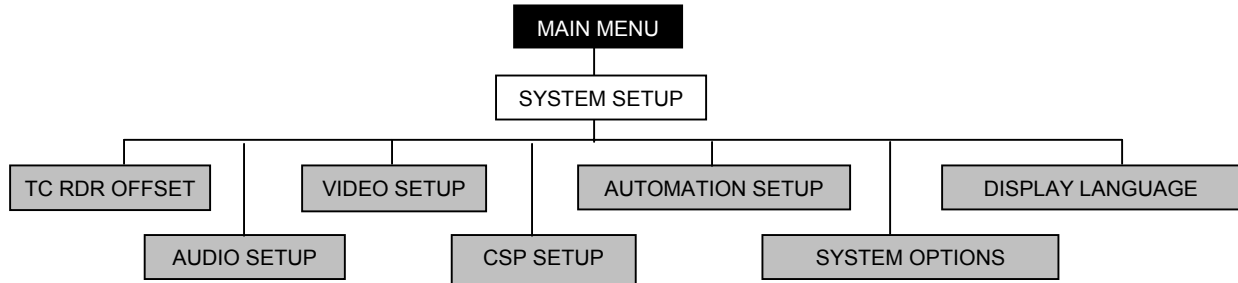

### 1.8.1. TC Reader Offset

This menu allows you to enter the appropriate offset required for your particular timecode reader. (See *Timecode Reader Sync Adjustment* (chapter 3) for the procedure for determining the correct offset.)

If you select TC Reader Offset, a screen like this will display, where you can change the setting.

```
Set Timecode Reader  
Offset:  
[ 30.00 ] Frames
```

Use ▲ and ▼ to change the frame count, then press **ENTER** to save your setting and exit.

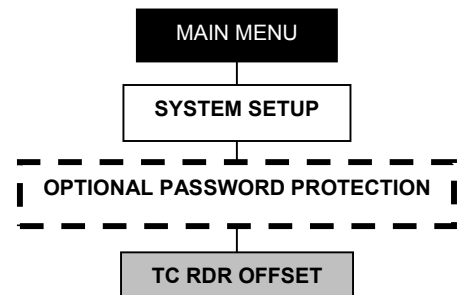

## 1.8.2. Audio Setup

Use the Audio Setup menu to perform audio level adjustments and to enable/disable language selection in the Playback menu.

### 1.8.2.1. Level Adjustment

The XD10 is set for 300mV reference tone output. This is what most cinema processors suggest for input. However, if changes are needed, follow these instructions.

**Select Audio**

- Reference Tone
- Pink Noise

Use ▲ and ▼ to move the cursor, then press **ENTER** to select.

This menu allows you to select a 1kHz Reference Tone (played through all channels), or Pink Noise (played through each channel sequentially) for level adjustment of each channel of audio. Pressing **ENTER** will display an adjustment screen for the first channel. The Pink Noise or Reference Tone will begin to play and continue to play as you cycle through the channels.

- Note:** 1kHz tone output at 00.0dB will be at 300mV.

<p><b>Adjust level for</b>  <b>Ch 1 (Left)</b>          [ +00.0 dB ]  <b>Tone on all channels</b></p>	<p>Press ► or <b>ENTER</b> to advance to the next channel. Press ▲ or ▼ to change level setting.</p>
---	--

The ▲ and ▼ buttons allow you to change the default setting (00.0 dB) of each channel from +06.4 dB to -06.2 dB. When you have set the desired level for the displayed channel, press ► or **ENTER** to advance to the next channel. Repeat for each of the channels in your system.

- For reference, The channel sequence is: Ch 1 (Left), Ch 2 (Right), Ch 3 (Center), Ch 4 (Sub Bass), Ch 5 (Left Surr), Ch 6 (Right Surr), Ch 7 (LC), Ch 8 (RC), Ch 9 (Back Surr), Ch 10 (Aux).

### 1.8.2.2. Language Versions

This menu allows you to enable or disable language selection in the Playback menu. Selecting **Enable** will give the operator access to all available languages via the **Playback: Soundtrack** menu. Selecting **Disable** will limit operator choices to running the language last loaded, or to have the language set via Automation. See the topic *Language Management for the XD10* on page 1-33 for more information.

- Language Versions is typically **disabled** in cinemas where only **one** language is used. It is typically **enabled** in cinemas where multiple language soundtracks are used.

**Language Versions**  
 [ ]Enabled  
 [ ]Disabled

Use ▲ and ▼ to move the cursor, then press **ENTER** to activate.

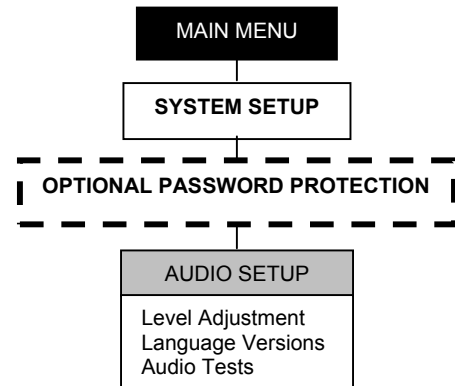



### 1.8.2.3. Audio Tests

This menu allows selection of Audio Tests, which are used for listening tests. System calibration is performed using the Level Adjustment menu (on the preceding page).

```

Audio Tests Menu
( )Pink Noise Cycle
( )Alignment Tones
( )Pink: Left
( )Pink: Left Surround
( )Pink: Center
( )Pink: Right Surround
( )Pink: Right
( )Pink: Sub Base
( )Flying Disc
( )Sonic Landscape
( )Bill and Buzz
  
```

Use ▲ and ▼ to move the cursor, then press **ENTER** to activate.

Flying Disc and Sonic Landscape are trailers

Bill and Buzz (if CSS option is installed) outputs subtitling, Rear Window captions, and narration audio

The following table provides detailed information about the Pink Noise Cycle tests.

Table 1-1. Pink Noise Cycle Tests

Track Description	Level	Duration	Channel(s)
5.1 Channel	-20 dBFS	10 sec. each	Sequence Order: L, C, R, LS, RS, SW
7.1 Channel	-20 dBFS	10 sec. each	Sequence Order: L, LC, C, RC, R, LS, RS, SW
8.1 Channel	-20 dBFS	10 sec. each	Sequence Order: L, LC, C, RC, R, LS, RS, BS, SW
9.1 Channel	-20 dBFS	10 sec. each	Sequence Order: L, LC, C, RC, R, LS, RS, BS, Aux, SW
6.0 Channel	-20 dBFS	10 sec. each	Sequence Order: L, C, R, LS, RS, SW (Full Range)
8.0 Channel	-20 dBFS	10 sec. each	Sequence Order: L, LC, C, RC, R, LS, RS, SW (Full Range)
9.0 Channel	-20 dBFS	10 sec. each	Sequence Order: L, LC, C, RC, R, LS, RS, BS, SW (F.R.)
10.0 Channel	-20 dBFS	10 sec. each	Sequence Order: L, LC, C, RC, R, LS, RS, BS, Aux, SW (F.R.)

Subwoofer bandwidth is 20 Hz to 125 Hz for the “.1” tracks.

Subwoofer bandwidth is 20 Hz to 20 kHz (Full Range / F.R.) for the “.0” tracks (Special Venue).

### 1.8.3. Video Setup

The Video Setup controls are present only if your unit is equipped with the Video Option. If this option is not installed, the controls in this menu section will be inactive. With the Video Option installed, this menu provides controls for optimal setup, calibration, and control of an installed digital video projection system.

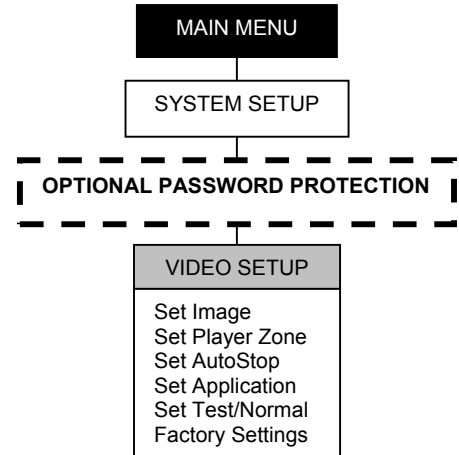

#### 1.8.3.1. Set Image

Select submenus for specifying the appropriate image resolution, for adjusting image brightness and contrast, or for adjusting image position on the screen. Once the optimal settings have been made, these controls will not need further adjustment unless the unit is connected to a different video projector.

Selecting any of the submenus will display an adjustment screen where you can alter the current setting using the ▲ and ▼ buttons. Press **ENTER** to confirm your setting and return to the **Set Image** menu.

- Select 1024 x 768, or 1280 x 1024 **Resolution**, to match that of the video projector in use.
- Play a video sample and adjust **Brightness** and **Contrast** for optimal viewing in your theater.
- Play a 16:9 video image and use the **Calibration** controls to center (**Location**) and squeeze (**Width**) the image as necessary to best fit your screen.

**Set Image Menu**

- Resolution
- Brightness
- Contrast
- Cal Location
- Cal Width

Use ▲ and ▼ to move the cursor, then use ► to open submenu.

Choose **Resolution** and this screen will display.

**Resolution Menu**

( ) 1024 x 768

( ) 1280 x 1024

Use ▲ and ▼ to move the cursor, then press **ENTER** to activate.

- Note:** Image calibration (Cal Location, next page) must be done separately for each resolution (1024x768 or 1280x1024).

Choose **Brightness** and this screen will display.

**Set Brightness**

**Brightness:** 55/100

Use ▲ and ▼ to change the Brightness factor, then press **ENTER** to Save your setting.

Choose **Contrast** and this screen will display.

**Set Contrast**

**Contrast:** 55/100

Use ▲ and ▼ to change the Contrast factor, then press **ENTER** to Save your setting.

Choose **Cal Location** (Calibrate Location) and screen shown next will display.

- ☑ **Note:** You must be playing a video in order to calibrate the video image. Also, calibration must be done separately for each resolution (1024x768 or 1280x1024).

Use U, D, L, R

To Adjust Image  
ENTER to Save and Exit

Use ▲ ▼ ◀ or ▶ to center the image on the screen, then press **ENTER** to Save your setting.

Choose **Cal Width** (Calibrate Width) and this screen will display.

Use Up / Down

To Adjust Width  
ENTER to Save and Exit

Use ▲ and ▼ to adjust the width of the image on the screen, then press **ENTER** to Save your setting.

### 1.8.3.2. Set Player Zone

Some video program material is designated for play only in designated markets. Use the Set Player Zone setting to identify your zone. Material designated for a zone other than the one set here, will not play on your system.

Each playlist has a zone associated with it when it is created. If the zone of the playlist matches the zone of the player, the playlist will be displayed and can be played.

- ☑ **Note:** Zone **00** is a wildcard that can be set on an individual playlist (meaning that playlist will play on any player regardless of player's zone setting). Or it can be set on the player (in which case all playlists will play).

#### VIDEO SETUP

Set Image  
Set Player Zone  
Set AutoStop  
Set Application  
Set Test/Normal  
Factory Settings

#### Set Player Zone

Player Zone = 00

Use ▲ and ▼ to change the number, then press **ENTER** to activate.

Press ◀ to exit this screen.

### 1.8.3.3. Set AutoStop

This menu allows you to determine the Stop behavior of video material when the XD10 is under Automation control. Select **Stop Immediately** to have Video shut off on receipt of an automated Stop command. Select **Stop at Seg End** to have the running video segment play to completion before Video is shut off.

Autostop Menu  
( ) Stop Immediately  
( ) Stop at Seg End

Use ▲ and ▼ to move the cursor, then press **ENTER** to activate.

### 1.8.3.4. Set Application

This menu allows you to adjust the video image to match the masking configuration used on your theater screen. Select **Common Height** (the default setting) or **Common Width**, as appropriate.

Application Menu  
( ) Common Height  
( ) Common Width

Use ▲ and ▼ to move the cursor, then press **ENTER** to activate.

### 1.8.3.5. Set Test/Normal

This menu is provided to allow the play of test images used in system troubleshooting. For normal operation, it should be left at the default setting, **Normal**.

```
Mode Menu
( )Normal
( )Test
```

Use ▲ and ▼ to move the cursor, then press **ENTER** to activate.

#### VIDEO SETUP

```
Set Image
Set Player Zone
Set AutoStop
Set Application
Set Test/Normal
Factory Settings
```

### 1.8.3.6. Factory Settings

There are various settings for the video that are initially set to factory defaults. These can be restored using this menu.

```
Factory Settings
Keep Current
Restore Vid Default
```

Use ▲ and ▼ to move the cursor, then press **ENTER** to activate.

Select **Restore Video Default** to restore the factory settings. A confirmation screen will display, similar to this example:

```
Settings changed
to defaults
Press ENTER
```

Press **ENTER** to exit.

Select **Keep Current** if you do not wish to change the current settings. This screen will display:

```
Settings
Not changed
Press ENTER
```

Press **ENTER** to exit.



### 1.8.4. CSP Setup

The CSP Setup controls are active only if your unit is equipped with the CSS Option. (See Appendix G for installation instructions.) If this option is not installed, the controls in this menu section will be inactive. With the CSS Option installed, this menu provides controls for optimal setup, calibration, and control of an installed subtitling projection system.

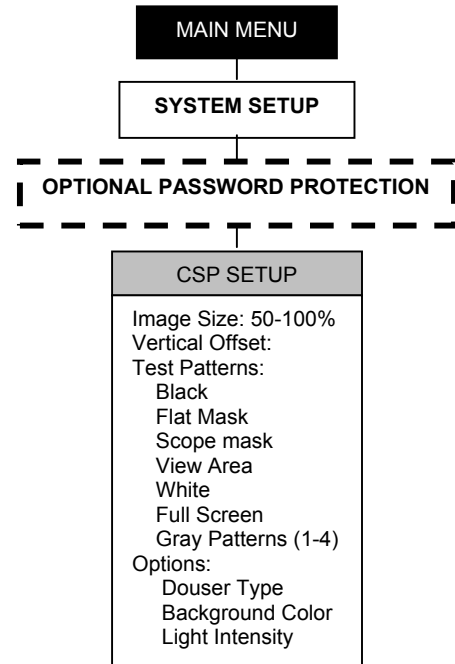

#### 1.8.4.1. Image Size

This menu allows you to select the size of subtitles. The system displays a grid pattern on the screen, which adjusts in size to reflect your choice. You can select from the different subtitle sizes supplied on the DTS-CSS subtitle disc. If you select a size that is not available, the system will use the closest available size.

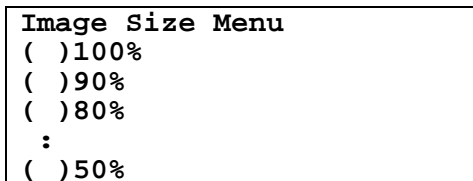

Use ▲ and ▼ to move the cursor, then press **ENTER** to activate the setting.

#### 1.8.4.2. Vertical Offset

This menu allows you to enter the appropriate vertical offset (in pixels) for the projected image. First select a test pattern (next topic), then use ▲ and ▼ to vertically adjust the projected image. The image will move as you adjust the offset.

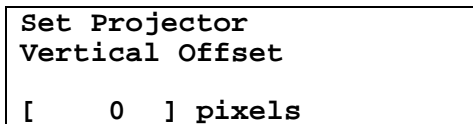

Use ▲ and ▼ to change the numerical setting, then press **ENTER** to Save the setting.

#### 1.8.4.3. Test Patterns

This menu allows selection from an array of test patterns used for optimizing subtitle display. (See Appendix G, *Cinema Subtitling System (CSS) Option* installation instructions for test procedures using these patterns.)

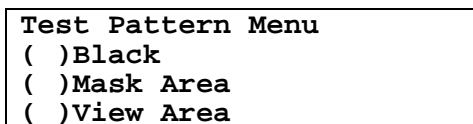

Use ▲ and ▼ to move the cursor, then press **ENTER** to activate.

Other choices include:

- White
- Full Screen
- Gray Pattern (1) thru (4)

### 1.8.4.4. Options

This menu gives you the option of specifying a black background for displayed subtitles, and lets you adjust the light intensity of subtitle projection, if necessary for optimal viewing.

<b>CSP Options</b>
<b>Douser Type</b>
<b>Background Color</b>
<b>Light Intensity</b>

Use ▲ and ▼ to move the cursor, use ► to open submenu.

The **Douser Type** submenu permits a choice between **Electronic** and **Mechanical** douser. The electronic type opens and closes for each subtitle. The mechanical type opens at the beginning of the show and closes at the end of the show.

<b>Douser Type</b>
( ) <b>Electronic</b>
( ) <b>Mechanical</b>

Use ▲ and ▼ to move the cursor, then press **ENTER** to activate.

The **Background Color** menu allows a choice between black and normal.

<b>Background Color</b>
( ) <b>Normal</b>
( ) <b>Black</b>

Use ▲ and ▼ to move the cursor, then press **ENTER** to activate.

The **Light Intensity** menu allows a choice between low and high.

<b>Light Intensity</b>
( ) <b>Low</b>
( ) <b>High</b>

Use ▲ and ▼ to move the cursor, then press **ENTER** to activate.

CSP SETUP
Image Size: 50-100%
Vertical Offset: Test
Patterns:
Black
Flat Mask
Scope mask
View Area
White
Full Screen
Gray Patterns (1-4)
Options:
Douser Type
Background Color
Light Intensity

The default setting is **High**. If the cooling fan stops running for some reason, the projector will switch to **Low** power. High power will resume when the fan signal is on again.

 **Caution:** If the projector is run at high power without the fan running, it will get hotter than normal and that could affect the projector life. Under normal circumstances it should not run under low power because it degrades the lamp life.

### 1.8.5. Automation Setup

The XD10 can be configured for automated control of film soundtrack and subtitle languages, video functions, and both video and audio playback formats. Software-assignable pins on the XD10 Automation connector provide straightforward configuration for connection to any cinema processor, and easy selection of default and fallback formats ensure optimal audio playback under most circumstances.

The Automation Setup menus provide ready access to predefined pin formats as well as the ability to create completely unique formats to suit your installation requirements. Additional menus in this section allow you to further customize your system via the XD10 I/O Control connector, to set defaults and fallback formats used by your automation system, and to perform testing of your configuration.

**AUTOMATION / CONTROL**  
 •Format  
 •I/O Control  
 •Test

Use ▲ and ▼ to move the cursor, use ► to open submenu.

#### 1.8.5.1. Format Assignment

The XD10 25-pin Automation connector has 8 user-assignable pins to allow customization for your particular cinema processor. This menu allows you to select predefined pin definitions appropriate for the most common cinema processors, to customize these settings, or to create completely unique versions, and to define fallback audio formats to be used for both Soundtrack and Video.

Note that the menus for Video Fallback will only be active if the XD10 Video Option is installed.

**FORMAT AUTOMATION**  
 •Pin Definitions  
 •Fallback Format  
 •Operating Mode

Use ▲ and ▼ to move the cursor, use ► to open submenu.

#### Pin Definitions

Choose **Pin Definitions** and this submenu will display.

**FORMAT PIN DEFS**  
 •Predefined Formats  
 •Custom

Use ▲ and ▼ to change the numerical setting, then press ► to open the next submenu.

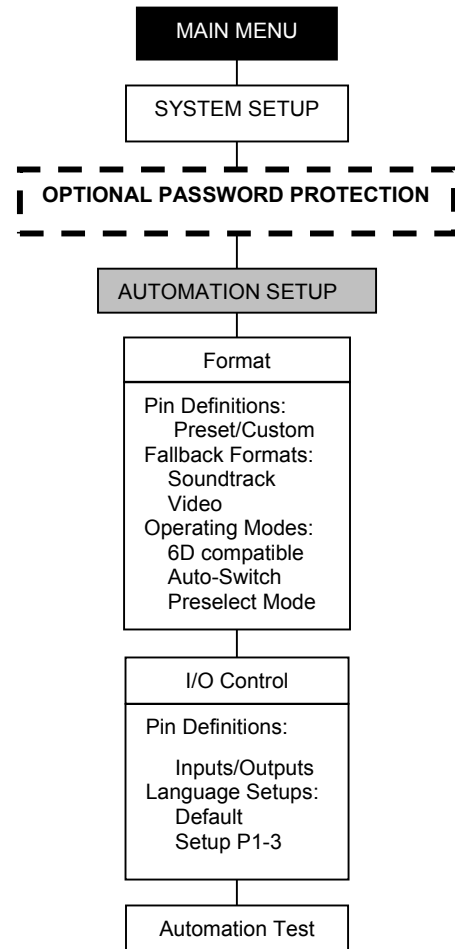

**Predefined Formats** automatically configure the pins correctly for the most commonly used cinema processors:

```
Automation Preset
( )DTS-6D Emulation
( )DTS-6AD/ECP
( )CP-65
( )CP-200
( )CP-500
( )CP-650
( )Sony D3000
( )UltraStereo JS
```

Use ▲ and ▼ to move the cursor, then press **ENTER** to Save the setting.

Select **Custom** to view the pin format for the current preset selection and to change the assignment of any or all of the 8 adjustable pins.

```
Format Pins
Pin 1: Mono
Pin 2: A
Pin 3: SR(1)
:
Pin 8:
```

Use ▲ and ▼ to move the cursor, then press ► to select a Pin.

When a pin is selected, a Change Pin screen will display for configuring the pin.

```
Change Pin X
( )Unused
( )Mono
( )A
( )SR (1)
```

Use ▲ and ▼ to move the cursor, then press **ENTER** to select a setting. Scroll down to **EXIT** or press ◀ to Exit this screen.

The available options include:

- Unused
- Mono
- A
- SR (1)
- SR (2)
- SR-D
- External
- Nonsync (1)
- Nonsync (2)
- Aux
- User 1
- User 2
- DTS (Pulse)
- DTS (Sustained)
- DTS-ES

Mono, A, SR (1) and SR (2) are optical formats used in audio header files.



## Fallback Formats

The Format menu also provides for selection of a “fallback” format to be used for soundtrack play whenever the primary selected audio format is not detected by the XD10. If your XD10 is equipped with the Video Option, you can select a fallback format for Video program material as well.

- Note:** The XD10 will switch to a pre-selected fallback format during soundtrack playback if:
- Timecode stops or becomes unreadable beyond the freewheel window.
  - The Reel/Serial numbers of the soundtrack do not match any of the soundtracks currently loaded into the XD10 hard drive.
  - Timecode continues beyond the end-of-reel as defined by the soundtrack file.
  - The XD10 detects an internal hardware or software error.

Format
Pin Definitions: Preset/Custom
Fallback Formats: Soundtrack Video
Operating Modes: 6D compatible Auto-Switch Preselect Mode

```
FALLBACK FORMATS
Soundtrack
Video
```

Use ▲ and ▼ to move the cursor, then press ► to open the next submenu.

## Soundtrack Fallback

Select **Soundtrack** to display and select from the options.

```
Soundtrack Fallback
( )Automatic
( )Mono
( )A
```

Use ▲ and ▼ to move the cursor, then press **ENTER** to select. Scroll down to **EXIT** or press ◀ to Exit this screen.

Soundtrack Fallback options include:

- Automatic
- Mono
- A
- SR (1)
- SR (2)
- SR-D
- External
- Nonsync (1)
- Nonsync (2)
- Aux
- User 1
- User 2
- DTS (Pulse)
- DTS (Sustained)
- DTS-ES

If **Automatic** is selected as a fallback format, audio errors will cause the XD10 to switch to the optical format (Mono, A or SR) specified in the soundtrack audio header.

## Video Fallback

If your XD10 is equipped with the Video Option, select **Video** to display and select from the options.

<b>Video Fallback</b>
( ) Mono
( ) A
( ) SR (1)

Use ▲ and ▼ to move the cursor, then press **ENTER** to select.  
Scroll down to **EXIT** or press ◀ to Exit this screen.

Format
Pin Definitions: Preset/Custom
Fallback Formats: Soundtrack Video
Operating Modes: 6D compatible Auto-Switch Preselect Mode

Video Fallback options include:

- Mono
- A
- SR (1)
- SR (2)
- SR-D
- External
- Nonsync (1)
- Nonsync (2)
- Aux
- User 1
- User 2
- DTS (Pulse)
- DTS (Sustained)
- DTS-ES

Note that the Video selection will be inactive unless the XD10 Video Option is installed.

### 1.8.5.2. Operating Modes

The XD10 may be configured to automatically switch audio formats. This menu allows selection of the automation mode: DTS-6D-Emulation, Auto-Switch or Preselect.

<b>Automation Mode</b>
( ) DTS-6D Emulation
( ) Auto-switch
( ) Preselect Mode

Use ▲ and ▼ to move the cursor, then press **ENTER** to activate.

Format
Pin Definitions: Preset/Custom
Fallback Formats: Soundtrack Video
Operating Modes: 6D compatible Auto-Switch Preselect Mode

#### DTS-6D Emulation

This mode is intended to allow direct replacement of a DTS 6D with an XD10, without altering the 6D's unique end-of-show behavior.

In this mode, the XD10 plays soundtrack audio in the DTS format. When the soundtrack reaches the last 2 minutes of the last reel, if it falls out<sup>1</sup> of digital mode, the XD10 switches to nonsync format. (Timing is determined by identifying the last reel in the audio file header, then subtracting 2 minutes from the end of the file – as determined by file size.)

#### AutoSwitch (Optical Formats)

In this mode, the XD10 switches to DTS format only if it is currently in one of the optical formats (Mono, A or SR). This allows the possibility of an alternate external format to be used without being overridden by the XD10.

<sup>1</sup> It "falls out" of DTS mode if there is not timecode or no audio to play.



### Preselect Mode (SRD compatible)

This mode allows the automation system to have more control over format switching. In this mode, the automation system must select the DTS format to activate XD10 automation.

When DTS is selected by the automation system, the XD10 will remain in a predetermined fallback optical format, switching to DTS when a soundtrack begins, and automatically switching back to the fallback format if the soundtrack decoder stops before the end of the show.

#### 1.8.5.3. I/O Control

The XD10 provides additional control options for language selection and Video Stop and Start functions via its rear panel I/O connector and the I/O Controls in the Automation Setup menu. This menu allows you to configure the XD10 to accept external control for video event triggering, to assign XD10 output control pins, to specify soundtrack and subtitling language defaults, and to define up to 3 setups for output.

I/O Control
Pin Definitions: Inputs/Outputs Language Setups: Default Setup P1-3

```
I/O CONTROL
Pin Definitions
Language Setups
```

Use ▲ and ▼ to move the cursor, then press ► to open the next submenu.

#### Pin Definitions

```
I/O PIN DEFINITIONS
Inputs
Outputs
```

Use ▲ and ▼ to move the cursor, then press ► to open the next submenu.

Select **Inputs** to display and select **Inputs 1, 2, and 3**.

```
INPUT CONTROL PINS
In 1:
In 2:
In 3:
```

Use ▲ and ▼ to move the cursor, then press ► to select.

When you select an Input, this assignment screen will display:

```
Change In 1
( ) Unassigned
( ) Start Video
```

Use ▲ and ▼ to move the cursor, then press **ENTER** to select.

Select one of the following assignments:

- Unassigned
- Start Video
- Stop Video
- Lang Setup (as defined for the corresponding pin # in the Language Setup menu.)
- TCR 1/2

Select **Outputs** to display and select **Outputs 1, 2 and 3**.

```
OUTPUT CONTROL PINS
Out 1:
Out 2:
Out 3:
```

Use ▲ and ▼ to move the cursor, then press ► to select.

When you select an Output, this assignment screen will display:



```

Change Out 1
( )Unassigned
( )Video Stop

```

Use ▲ and ▼ to move the cursor, then press **ENTER** to select.

Select one of the following assignments:

- Unassigned
- Video Stop
- DTS output
- ES Output

## Language Setups

This menu allows you to define 3 soundtrack and subtitling combinations to be selected when I/O pin assignment for pin 1, 2 or 3 is set to **Lang Setup**. Default selection for Soundtrack and Video is also provided.

See *Using Automated Language Setups* on page 1-34 for an example.

I/O Control
Pin Definitions: Inputs/Outputs Language Setups: Default Setup P1-3

```

LANGUAGE SETUP MENU
Default
Setup Input 1
Setup Input 2
Setup Input 3

```

Use ▲ and ▼ to move the cursor, then press ► to open the next submenu.

- Select **Default** to choose from the available language options for Soundtrack or Video. The selection made here will be used as a default for I/O control pins assigned to **Lang Setup** if no Setup for the pin # is defined.

```

LANGUAGE DEFAULT
Soundtrack
Subtitle

```

Use ▲ and ▼ to move the cursor, then press ► to open the next submenu.

The Soundtrack Default and Subtitle Default screens offer the same choices.

```

Soundtrack Default
( )Arabic
( )Basque
( )English
( )French

```

Use ▲ and ▼ to move the cursor, then press **ENTER** to select.

Scroll down to **EXIT** or press ◀ to Exit this screen.

```

Subtitle Default
( )CSP Off
( )Undefined
( )Arabic
( )French

```

Use ▲ and ▼ to move the cursor, then press **ENTER** to select.

Scroll down to **EXIT** or press ◀ to Exit this screen.

- Select **Setup P1, P2** or **P3** to assign the soundtrack and subtitle languages you want to be used when I/O Control pins 1, 2 or 3 are assigned to **Lang Setup**.

```

LANGUAGE SETUP 1
Soundtrack
Subtitle

```

Use ▲ and ▼ to move the cursor, then press ► to open the next submenu.



The Language Setup screens for Soundtrack and Subtitle offer similar choices.

```
Language #1
( )Arabic
( )Basque
( )English
( )French
```

Use ▲ and ▼ to move the cursor, then press ENTER to select.

Scroll down to **EXIT** or press ◀ to Exit this screen.

```
Subtitle #1
( )CSP Off
( )Undefined
( )Arabic
( )French
```

Use ▲ and ▼ to move the cursor, then press ENTER to select.

Scroll down to **EXIT** or press ◀ to Exit this screen.

#### 1.8.5.4. Automation Test

Once you have made your formatting selections, you can confirm the functionality of pins 1-8, as well as I/O Control pins 1-3, and the signal for your CSP projector fan, by selecting **Automation Test** from the **Automation Setup** menu.

Move the displayed asterisk to select one of the 8 dashed lines representing pins 1-8, or over one of the dashed lines representing Outputs 1-3 and the CSP projector fan. Press **ENTER** to pulse the indicated line (and display the current pin assignment for the line being tested).

```
Automation Test
Fmt:----- In:----
[Pin 1: Mono      ]
[Enter] to Pulse
```

Use ▲ and ▼ to select PIN. The display shows the Pin assignment. Then press **ENTER** to pulse (test).

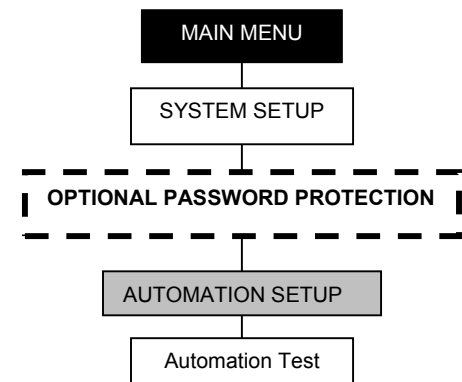

### 1.8.6. System Options

The System Options menu allows you to select password protection of the Setup controls, to enable network communications, and to set the system clock.

#### 1.8.6.1. COM2 Configuration

Use this menu to set COM2 to either the EMA Port (for CSP video control) or to the IR Port (for wireless downloading Video Log files from the XD10 to a laptop computer).

- If you need Video Logging AND you are also using the subtitling projector, you MUST switch this setting back to EMA Port when you are finished downloading the log file.
- When this setting has been changed, you must REBOOT for the change to take effect.

```

COM2 Configuration
( )EMA Port
( )IR Port
    
```

Use ▲ and ▼ to move the cursor, then press ENTER to activate your choice. Then REBOOT for the change to take effect.

#### 1.8.6.2. Set Password

Once your system is configured and installed, you can limit access to all of the XD10 Setup menus by assigning a 3-digit password. Once a password is assigned, selecting **System Setup** from the **Main** menu will trigger display of a Password Request window. Unless the correct digits are entered, access to the Setup menus will be denied, Setting the Password to **000** (the default) will provide full access to any system operator and de-activate the Password Request screen.

```

Password
[ 0 0 0 ]
  *
    
```

To set a Password, use ▲ and ▼ to set the digit that is marked with an asterisk in the display. Use the ◀ and ▶ to move the asterisk from one digit to another.

Press **ENTER** to activate the password.

- Note:** Pressing the Left button while the asterisk is beneath the leftmost digit, will execute this button's normal behavior of backing you out of the menu – without changing the Password.  
Write down your password and keep it in a safe place. If you forget your password, you can call DTS Customer Support for assistance.

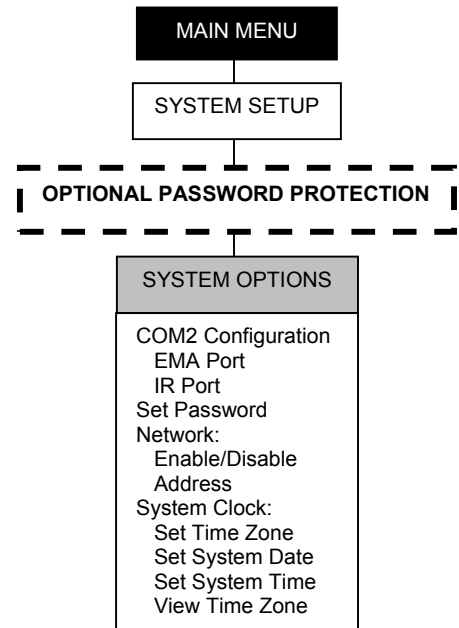

### 1.8.6.3. Network

This menu lets you **Enable** or **Disable** network communication, and display the Network IP **Address** if the system is connected to a network and communication is enabled.

```
NETWORK MENU
Enable/Disable
Address
```

Use ▲ and ▼ to move the cursor.  
Then press ► to open the selected submenu.

Choose **Enable/Disable** and this submenu will display.

```
Network Enable
( )Disabled
( )Enabled
```

Use ▲ and ▼ to move the cursor.  
Then press **ENTER** to activate.  
Press ◀ to exit.

Choose **Address** and a screen showing the IP Address will display.

```
Network IP Address
[XXX.XX.X.XX]
```

Press ◀ to exit.

### 1.8.6.4. System Clock

The System Clock menus allow you to view or set the Date, Time and Time Zone for your unit. Setting the time zone will allow the XD10 to automatically accommodate Daylight Savings Time. (The date, time, and time zone settings are only needed for video logging.)

```
SYSTEM CLOCK MENU
Set Time Zone
Set System Date
Set System Time
```

Use ▲ and ▼ to move the cursor.  
Then press **ENTER** to activate.  
Press ◀ to exit.

#### Set Time Zone

Choose **Set Time Zone** and first the Current Time Zone screen will display.

```
Current Time Zone:
[Enter] to select
[America/Los Angeles]
```

Press **ENTER** to open the change screen. Press ◀ to exit without changing.

Press **ENTER** if you wish to change the current setting.

```
Select Time Zone
Location:
[Americas]
```

Use ▲ and ▼ to cycle through the options. Then press **ENTER** to make your selection.

In this example, if [Americas] is selected, the next submenu will display.

```
Select Country
[United States]
```

Use ▲ and ▼ to cycle through the options. Then press **ENTER** to make your selection.

Continuing this example, if [United States] is selected, the next submenu will display.

```
Select Time Zone
and hit 'Enter'
[America/Los_Angeles]
```

Use ▲ and ▼ to cycle through the options. Then press **ENTER** to make your selection.

## Set System Date

Choose **Set System Date** and this screen will display.

```
Set Date:
[MM:DD:YYYY]
[04:01:2003]
*
```

To set the date, use ▲ and ▼ to set the digit that is marked with an asterisk in the display. Use the ◀ and ▶ to move the asterisk from one digit to another. Press **ENTER** to activate the date and exit.

## Set System Time

Choose **Set System Time** and this screen will display.

```
Set Time:
[hh:mm:ss]
[11:45:20]
*
```

To set the time, use ▲ and ▼ to set the digit that is marked with an asterisk in the display. Use the ◀ and ▶ to move the asterisk from one digit to another. Press **ENTER** to activate the time and exit.

### 1.8.7. Display Language

This menu allows you to select the language used on all of the XD10 menu displays. Select English (the default setting), French, German, Italian or Spanish.

```
DISPLAY LANG
English
French
German
Italian
Spanish
```

## 1.9. Info

The Main menu | Info menu displays the Version and the MAC Address submenus.

### 1.9.1. Version

Selecting **Version** from the **Info** menu will display the software version currently installed in the XD10. This information is used when upgrading system software.

### 1.9.2. MAC Address

Selecting **MAC Address** from the **Info** menu will display the unique MAC address of the XD10. This information is needed to order and install software options.

The Mac Address is the unique address for this particular XD10 player that was assigned at the DTS factory. It is used as a network identifier, and for implementing option upgrades and other future applications. When ordering option upgrades for your XD10, DTS Customer Service will require the Mac Address of your XD10 unit.

## 1.10. Language Management for the XD10

In selected theaters there may be a requirement to play different dubbed soundtrack versions for the same film. A theater may also desire to change versions throughout the day.

In the XD10, multiple versions of a film may be copied onto the hard drive. Since all of the versions are assigned the same serial number, there needs to be additional information given to the XD10 to select which version should be played.

In order for XD10 to accurately identify the languages on the disc, a language identification is added to the audio file header. This ID is an enumerated value. The XD10 has a table that relates the enumerated value to the text description of the language. See Appendix D, *Language Management*.

### 1.10.1. Trailer Considerations

The language version must be set to the language of the trailer files, or they will not play.

“Last installed” means the last audio file installed for that serial number and reel number combination. There is not really a last installed language because you can install three different shows with different languages and they will all play under “Last Installed”. The same is true if language versions is disabled.

If you installed the same show with three different languages, then only the last one loaded will play under “Last Installed”. This also is true if language versions is disabled.

### 1.10.2. Language Versions Enable

In most cases, the XD10 is installed at a location where multiple languages will NOT be used. In that case the Language Versions option should be **disabled**. When disabled, all other language version menu options and features are turned off, and the XD10 will not store multiple versions of the any feature. The last language version installed will overwrite any previous version.

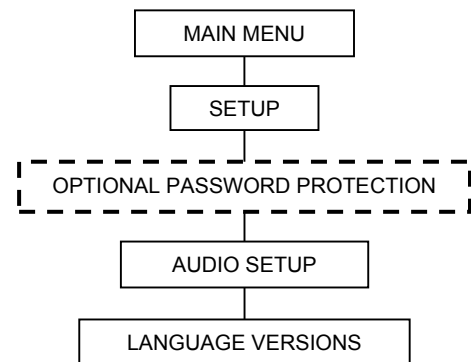
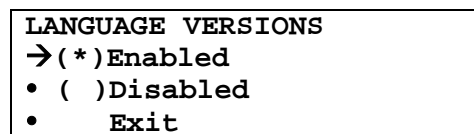

### 1.10.3. Language Versions Selection

This option is only necessary in cinemas where multiple languages are used for films. This selection is made by the projectionist to set up for the next show.

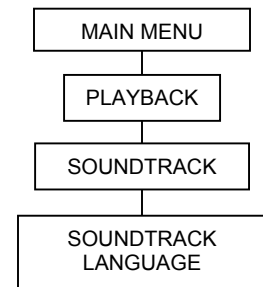
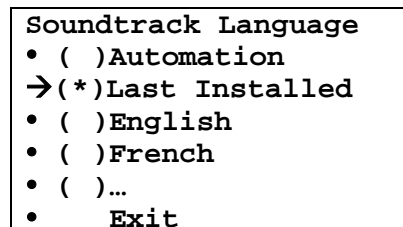

- **Last Installed**– the last audio file installed for that serial number and reel number combination.

There is not really a last installed language because you can install three different shows with different languages and they will all play under “Last Installed”. (The same is true if Language Versions is disabled.)

If you installed the same show with three different languages, then only the last one loaded will play under “Last Installed”. (The same is true if Language Versions is disabled.)

- **Automation** – the automation signals are used to select the language. This option only shows up if applicable.
- **English, French, etc.** – this specifically selects the language to be used in the next playback.
- ☑ **Note:** If the selected language does not exist on the hard drive, then the player defaults to optical.

#### 1.10.4. Using Automated Language Setups

If automated language selection is desired, the installer must configure the automation to control the language playback.

1. Select 1 to 3 input pins from the I/O Control port that will be used to switch languages.

```
I/O Control
→ Pin Definitions
• Language Setups
• Exit
```

```
I/O Pin Definitions
→ Inputs
• Outputs
• Exit
```

```
Input Control Pins
→ In 1: Unassigned
• In 2: Unassigned
• In 3: Unassigned
```

```
Change In 1
→ (*) Lang Setup 1
• ( ) Lang Setup 2
• ( ) Lang Setup 3
```

Press **ENTER** to select.

Other options include:  
 Unassigned  
 Start Video      Stop Video  
 Projector ON

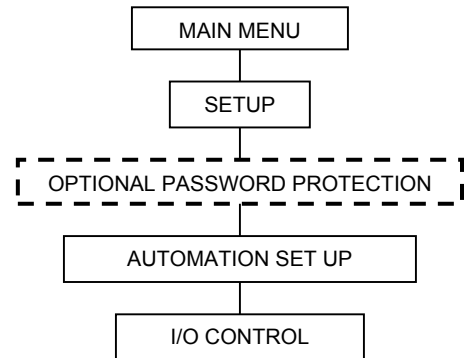

- Assign default audio language (no closure) under Language Setups.

```
I/O Control
• Pin Definitions
→Language Setups
• Exit
```

```
LANGUAGE SETUP MENU
→Default
• Setup #1
• Setup #2
```

```
LANGUAGE DEFAULT
→Soundtrack
• Subtitle
• Exit
```

```
Soundtrack Default
→(*)English
• ( )French
• ( )German
```

Press **ENTER** to select.

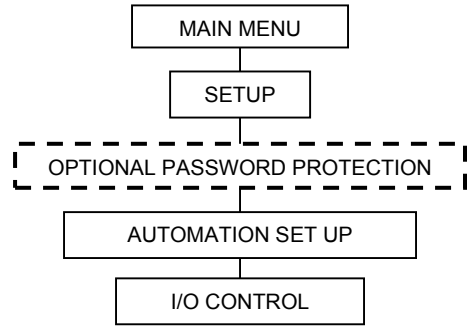

- If CSS is installed assign a CSS subtitle language for the default setting, if applicable.

```
LANGUAGE SETUPS
→Default
• Setup #1
• Setup #2
```

```
LANGUAGE DEFAULT
• Soundtrack
→Subtitle
• Exit
```

```
Subtitle Default
→(*)English
• ( )French
• ( )German
```

Other options include:  
 CSP Off  
 Undefined  
 Press **ENTER** to select.

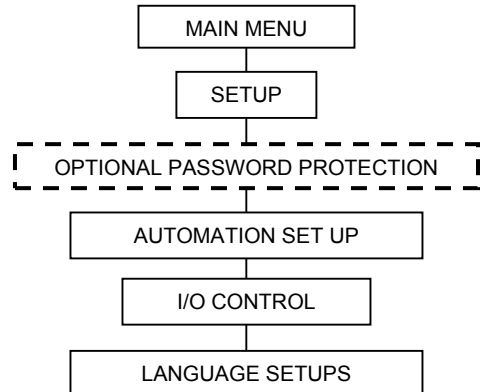

- Repeat steps 2 and 3 for number of alternate language setups desired.

To be fully automated, the user must select automation for both soundtrack and subtitle language selections in the playback menu. Alternatively, you can automate the soundtrack and manually select the subtitle, or vice-versa. The user can override the automation by selecting a particular language for either audio or subtitles (or both).

### 1.11. Check Procedures

When a projectionist initially sets up a feature to be played in different languages, they should check that all of the required languages have been installed in the XD10.

The **Contents | Features** and **Contents | Trailers** display menus will list all the installed features and trailers, in the order they were loaded.

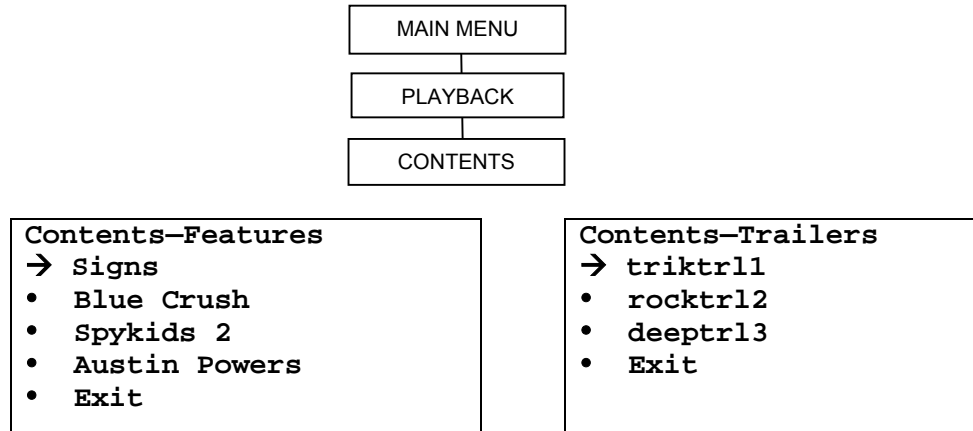

Use ▲ and ▼ to scroll through the list.

### 1.12. Compatibility with Existing Discs

When loading a disc that does **not** contain the Language ID value, and when Language Versions is **enabled**, the program will ask the user to identify the language.

- ☑ If Language Versions is **disabled**, the XD10 program does NOT prompt you to identify the language. (See *Language Versions Enable*, page 1-33.)

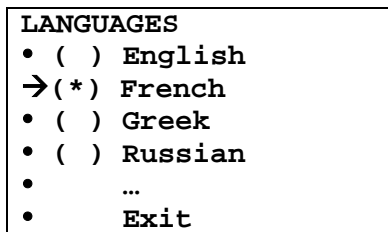

After selecting a language, a confirmation screen will display.

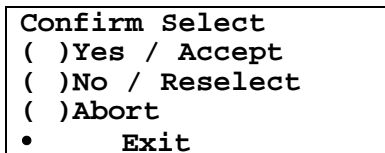

Use ▲ and ▼ to move the cursor, then press ENTER to activate.

- **Yes** – will begin downloading the disc.
- **No** – will return to the previous menu to make another language selection.
- **Abort** – will eject the disc (not copy it).



## 2. Installation

This chapter includes unpacking and inspection advice, a list of XD10 components and options, XD10 installation procedure, including Timecode Reader head instructions and XD10 mounting and connection instructions. In addition, connector pinouts and information about XD10 interactivity with other cinema processors is provided. Supplemental information can be found in:

Appendix A, XD10 System Parts List

Appendix B, XD10 Installation Diagrams (including Timecode Reader)

Appendix F, Video Option Installation

Appendix G, Cinema Subtitling System (CSS) Options Installation and Troubleshooting

**Refer to the Installation Checklist on page ix near the front of this manual.**

### 2.1. Unpacking and Inspection

DTS packaging is designed to handle normal shipping and handling. Damages incurred once equipment leaves DTS premises are the customer's responsibility. Upon receipt of shipment, thoroughly inspect the package and contents for signs of damage. Report any shipment damage to the carrier at once, and save all packing materials for their inspection.

#### EMI Notice

This equipment has been tested and found to comply with the limits for a Class A digital device, pursuant to part 15 of the FCC Rules. These limits are designed to provide reasonable protection against harmful interference when the equipment is operated in a commercial environment. This equipment generates, uses, and can radiate radio frequency energy and, if not installed and used in accordance with the instruction manual, may cause harmful interference to radio communications. Operation of this equipment in a residential area is likely to cause harmful interference in which case the user will be required to correct the interference at their own expense.

#### Canadian Department of Communications compliance statement

This equipment does not exceed Class A limits per radio noise emissions for digital apparatus set out in the Radio Interference Regulation of the Canadian Department of Communications. Operation in a residential area may cause unacceptable interference to radio and TV reception requiring the owner or operator to take whatever steps are necessary to correct the interference.

#### Avis de conformite aux norms du ministere des Communications du Canada

Cet equipment ne depasse pas les limites de Classe A D'emission de bruits radioelectriques pour les appareils numeriques telle que perscrites par le Reglement sur le brouillage radioelectrique etabli par leministere des Communications du Canada. L'exploitatin faite en mileu residential peut entrainer le brouillage des receptions radio et television, ce qui olbigerat le proprietaire ou l'operateur a prendre les dispositions necessaries pour en eliminer les causes.

#### CE

“Warning” This is a Class A product. In a domestic environment this product may cause radio interference in which case the user may be required to take adequate measures.

## 2.2. System Components

The following is a list of the standard components for an XD10 shipment. Refer to the actual packing slip from your order to verify the contents of your shipment. Contact DTS immediately if items listed on your packing slip are missing.

- DTS XD10 Player and power cord
- Timecode Reader Head, 35mm
- Reader Head Mounting Bracket
- Timecode Reader Head Interconnect Cable, 30 ft.\*
- Analog Output Cable, 25-pin “D” M/F, 6 ft.\*\*
- Digital Output Cable (option)
- Interface Items (cables, breakout boards) for the following processor types will be provided (when designated at time of order). Refer to Table 2-1 on next page.
  - Dolby CP45/CP65
  - Dolby CP55
  - Dolby CP200
  - Dolby CP500
  - Dolby CP650
  - UltraStereo VX 12-ch Series
  - UltraStereo JS Series
  - Panastereo
  - SMART MOD VI and VII
  - Sony DFP-D3000
  - DTS-6AD
  - DTS-ECP
- Automation (logic) cable (varies per CP)
- Installation Hardware (screws, brackets)
- This installation and operations manual
- DTS trailer (logo) films, two scope and two flat
- DTS marquee panels (4 inches and 8 inches)

\*Two projector (change-over) systems use a “Y” cable for Timecode and include an additional reader head, mounting bracket, and hardware.

\*\*Analog output cable (DTS Part #2503-0014-00) is used with cinema processors capable of discrete multi-channel input: Dolby, Kintek, Pana-Stereo, RGM, Smart, and UltraStereo JS Series.



## 2.3. XD10 Interconnection to Cinema Processors

This table identifies cables and breakout boards necessary when connecting the XD10 to specific cinema processors.

Table 2-1. XD10 Interconnection to Cinema Processors

CP	Audio Cable	Automation Cable	Other	Drawing Number (in Appendix B)
CP45	E680 Analog Out to J5	E681 cable and D716 Logic Breakout Board		E728
CP65	Analog Out PN 2503001400 and D574 6-track Breakout Card	E681 and D564 Logic Card		E700
CP65 – DA10/DA20	E684 Analog Out to Audio In on DA10/DA20	E681 and D564 Logic Card	CP Sense Control cable PN 2503001400 from CP65 to DA10/DA20	E701
CP55 Mono Surround	PN 2503001400 and D572 Audio Breakout Card	E681 cable and D565 Logic Breakout Card	E712 SW Switch Card	E734
CP55 Stereo Surround	PN 2503001400 and D572 Audio Breakout Card	E681 cable and D565 Logic Breakout Card		E735
CP200 with CAT 160	PN 2503001400	E723 cable and E557 Breakout Board	D712 cable (2x)	E732
CP200 with SRD and CAT 560	PN 2503001400	E723 cable and E557 Breakout Board	E743 cable	E733
CP200 with CAT 560	PN 2503001400	E723 cable and E557 Breakout Board	D712 cable (2x), E741 power to E557	E742
CP500	E683 Analog Out to 6ch Audio In	PN 2503001400 and E682 Adapter cable		E699
CP650	E683 Analog Out to 6ch Audio In	PN 2503001400 and E682 Adapter cable		E694
UltraStereo JS Series	Analog Out PN 2503001400 and D575 Ultrastereo 6-track Breakout Card	E681 and D571 Ultrastereo Logic Breakout Board		E726
DTS 6AD or DTS-ECP	Analog Out PN 2503001400	PN 2503001700 25-pin D M/M 6 ft		E726
Panastereo	Analog Out PN 2503001400	E724 Automation Cable		E727
SMART MOD VI and VII	E709 dual-purpose	E709 dual-purpose		E730
Sony DFP-D3000	E720	E721		E722



### 2.3.1. DTS XD10 Interaction with Other Cinema Processors

- ☑ In general, the XD10 is not compatible with older cinema processors (manufactured 1993 and earlier) unless the processors have been modified.
- ☑ See Appendix B for interconnect and cable diagrams.

#### 2.3.1.1. Dolby CP200 Operation

When the DTS XD10 switches to digital, the normal signal paths are interrupted, and DTS signals are inserted just prior to the Dolby EQ cards, in effect taking over the cinema processor.

**CP200:** Program the automation optical default format to either “04” A-TYPE or “05” SR – whichever the film requires.

When the DTS XD10 switches out of digital, the cinema processor is released and reverts to the format previously selected.

Unless modified, these cinema processors do not have a subwoofer input. In this case, DTS inserts the subwoofer signal post-fader; the fader or mute will not affect the subwoofer level.

#### 2.3.1.2. Dolby CP45, CP55, CP65, CP500, CP650, UltraStereo JS Series, and SMART Operation

The DTS XD10 will automatically pulse the audio processor to the digital format when it starts to play a digital sound track. Whenever the XD10 drops out of digital, a pulse will be sent to switch the audio processor back to optical format.

The DTS-XD10 will only pulse the audio processor into digital format when it first switches to digital. Set the automation/cues to disallow audio format change once the DTS has switched into digital (for example, when the show is re-started after a film break).

**CP500:** Must have the Cat. 685 (analog input card) installed. DTS is normally accessed through Format 11.

**SMART: Mod VI and VII** uses the DTS interface cable E709.  
For other SMART cinema processors, contact Smart directly at (800) 45-SMART or +1.770.449.6698.

#### 2.3.1.3. Dolby DA10 / 20 SR-D™ System

The DTS XD10 can be connected to the Dolby SR-D™ system without affecting performance of the Dolby system. The DA20 connects to the appropriate XD10 breakout board. When the XD10 is off, the DA10/20 output is routed through the breakout board. When the XD10 system is on and playing in digital, the DA10/20 connection (to the cinema processor) is switched out on the breakout card and the DTS digital sound track is given to the cinema processor. The SR-D™ system should be powered down when playing DTS.

#### 2.3.1.4. Sony SDDS™

The DTS XD10 system does not connect to, and has no affect on, the DFP-D2000 and DFP-D2500. It does connect to the DFP-D3000 and could be connected to a DCP1000. See the cable and interface drawings in Appendix B.

## 2.4. Installation Procedures

- Refer to the Installation Checklist on page ix near the front of this manual.**

The DTS system consists of two major components: ① DTS Timecode Reader Head and ② DTS XD10 Cinema Media Player. The following is a generic procedure intended to supplement the processor installation instructions for your specific manufacturer's system. Wiring diagrams are located in Appendix B *Installation Diagrams*.

### 2.4.1. Preliminary Inspection

Before installing the DTS XD10, we recommend you take a complete inventory of system components to minimize problems or questions during installation. Additionally, save all packing materials until installation is complete in the unlikely event that factory return of parts is required.

### 2.4.2. Timecode Reader Head Installation

The Timecode Reader Head is designed to be mounted onto most projectors with a single mounting bracket.

1. Position the appropriate DTS mounting bracket on the same bolt pattern as the reel arm and bolt securely in place (see “bracket mounting diagrams” in Appendix B).

If both 35mm and 70mm reader heads are to be used on the same bracket, add spacer breakaway plates to the readers. See *DTS 35mm and 70mm Readers, Switchable, Using the Same Bracket*, in Appendix B.

2. Install the Timecode Reader Head onto the DTS mounting bracket and bolt into place with supplied hardware.
3. Reinstall the reel arm on the top bolt pattern of the DTS mounting bracket.
4. Align the DTS mounting bracket and the reel arm. Align film along the path from the reel arm, through the mounted DTS Timecode Reader Head, to the projector.

- Important:** The DTS timecode reader **MUST** have a straight film path (no angles or twists) and at least a small amount of tension. Use the auxiliary flanged roller on the timecode reader head to avoid film “walk out” and to stabilize the film. (See *Installation Procedure – Timecode Reader Head Auxiliary Roller* in Appendix B of this manual.) Additional guide rollers may be added to ensure proper film tension – this is most critical on platter systems.

5. Connect the 9-pin timecode cable and route to the sound processor rack for interconnect with the XD10 player rear panel Timecode connector.

#### 2.4.2.1. Two projector (change-over) theaters

- Be sure to place each reader head at the same place on the projectors. **In order for the movie to play in sync, offset values must be the same for each projector.**

### 2.4.3. DTS XD10 Player Installation

#### 2.4.3.1. Rack Mounting and Connection

The DTS XD10 player is designed to integrate into your existing theater sound system, without affecting normal theater operation. All interconnects are standalone, and most systems require no cuts or jumpers.

The XD10 requires 3U of standard rack space (5 1/4 x 15 x 19 inches) for proper mounting. Select a space in the sound rack within three feet of the cinema processor to which you are connecting.

1. Bolt the XD10 into the selected rack space.
2. Check that the XD10 front panel power switch is in the OFF position.
3. Connect the supplied power cable between the XD10 and your power source.

 **Caution:** Because the XD10, like any other computer-based system, can be damaged by power line surges, we recommend using a computer-grade surge/spike suppresser.

4. Connect the analog and logic cables/cards to your cinema sound processor. (See Appendix B for installation diagrams – including installation into sound racks containing digital sound systems from Dolby and/or Sony.)

- If installing to a SMART cinema processor, contact SMART directly at (800) 45-SMART. DTS does offer SMART interface cables: for MODVI or VII use DTS #E709.

#### **2.4.3.2. Rack Mount Considerations**

If this product is installed in a closed or multi-unit rack assembly, the following items must be considered.

- The ambient temperature within the rack may be greater than room ambient temperature. The maximum temperature for the equipment in this environment is 50°C. Consideration should be given to the maximum rated ambient.
- Ensure adequate airflow for cooling purposes on all sides of rack-mounted equipment. Ventilation fans and louvers must not be blocked.
- Check nameplate ratings to ensure there is no overloading of supply circuits that could have an effect on over-current protection and supply wiring.
- Reliable grounding of this equipment should be maintained. Particular attention should be given to supply connections when connecting to power strips, rather than direct connections to the branch circuit.
- A quality surge/spike suppresser power strip is recommended to protect the unit.

## 2.5. XD10 Connectors

Refer to installation drawings in Appendix B. The back panel of the XD10 provides connectors for these functions:

- receiving signals from the timecode reader
- output of main audio, digital audio, and descriptive Narration audio
- output of subtitles video and control signals to the subtitles projector
- output of data and control signals to the cinema processor
- data output to a Rear Window scrolling message system
- optional video card output for pre-show video

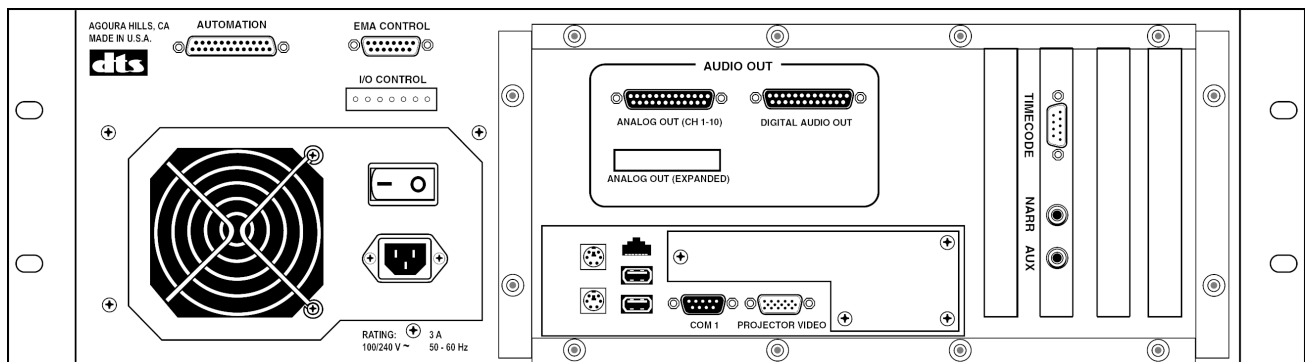

### Connector Pinouts

ANALOG OUT (CH 1 – 10) DB25M	
Pin	Description
1	AUDIO RETURN
2	RIGHT SURROUND
3	AUDIO RETURN
4	AUDIO RETURN
5	AUDIO RETURN
6	AUDIO RETURN
7	AUDIO RETURN
8	AUDIO RETURN
9	AUDIO RETURN
10	AUDIO RETURN
11	AUDIO RETURN
12	AUDIO RETURN
13	AUDIO RETURN
14	LEFT
15	LEFT SURROUND
16	RIGHT CENTER
17	RIGHT
18	LEFT CENTER
19	CH 9
20	CENTER
21	S (MONO SURR)
22	N/C
23	CH 10
24	SUBWOOFER OUTPUT
25	N/C

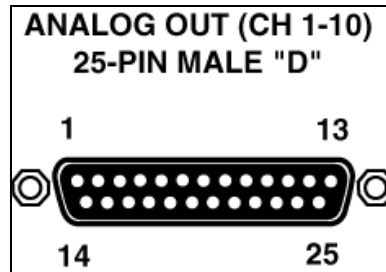

Audio Return = common or audio ground

AUTOMATION – DB25F	
Pin	Description
1	FORMAT 0
2	FORMAT 1
3	FORMAT 2
4	FORMAT 3
5	FORMAT 4
6	FORMAT 5
7	FORMAT 6
8	FORMAT 7
9	N/C
10	N/C
11	N/C
12	USER GND
13	USER SUPPLY +5V to +15V @ 40mA (required for status feedback)
14	N/C
15	N/C
16	N/C
17	N/C
18	N/C
19	N/C
20	N/C
21	N/C
22	N/C
23	N/C
24	N/C
25	N/C

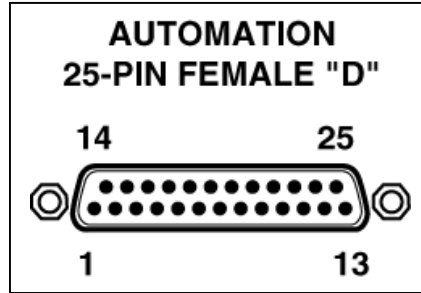

TIMECODE – DB9M	
Pin	Description
1	TIMECODE SIGNAL (P1)
2	TIMECODE SIGNAL (P2)*
3	N/C
4	N/C
5	+5VDC @ 250mA TO READER HEAD
6	GND
7	GND
8	GND
9	LED DRIVE SIGNAL TO READER HEAD (Timecode Valid signal – active low)

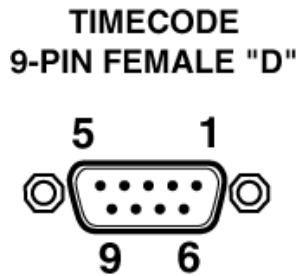

\* Pin 2 is only connected if a second projector is used (with a Y cable)



EMA CONTROL – DB15F	
Pin	Description
1	N/C
2	N/C
3	EMA FAN SENSE
4	COM 2 RX
5	COM 2 TX
6	COM 2 GND
7	N/C
8	EMA DOUSER CONTROL
9	+12V
10	+12V
11	+12V
12	+12V
13	GND
14	GND
15	GND

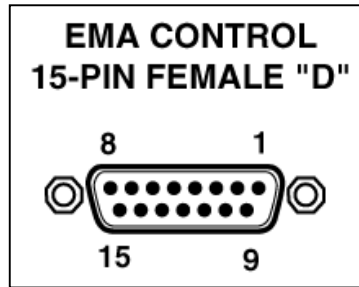

COM 1 – DB9M	
Pin	Description
1	DCD IN
2	RD IN
3	TD OUT
4	DTR OUT
5	SIG GND
6	DSR IN
7	RTS OUT
8	CTS IN
9	RI IN

**PROJECTOR VIDEO – HD15F**  
 VGA Connection for CSP Projector or to support optional video card output of pre-show video.

Digital output connector pinouts will be identified on the digital output card drawings when they are released.

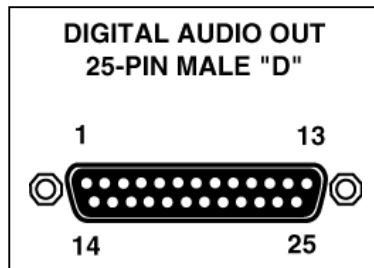

## 2.6. Options List

These options are enabled via specific licensing from DTS.

- Subtitling and Access capabilities (CSS Option) that include these features:
  - Projecting subtitles or captions directly onto the screen.
  - Control of WGBH Rear Window<sup>®</sup> Captioning – reversed captions on a light-emitting diode (LED) text display which is mounted in the rear of a theater. Patrons use transparent acrylic panels attached to their seats to reflect the captions so that they appear superimposed on or beneath the movie screen.
  - Output of descriptive audio narration for patrons who are visually impaired (via infrared or RF transmitter and headsets).
  - The auxiliary equipment – data wall, reflective panels, transmitter and headphones – are available from third party sources or obtainable through DTS.
- DTS Digital Audio Output Card – to output digital audio
- DTS Video Card – to output standard definition digital video for alternative media

## 2.7. Options Setup and Testing

For instructions to install and configure these options, see the appropriate reference:

- Cinema Subtitling System (CSS) Option -- see Appendix G of this manual.
  - includes Cinema Subtitles Projector (CSP) option
  - Descriptive Audio Narration option
  - Rear Window scrolling captions option
- Video Option – see Appendix F of this manual.
- Digital Audio option – (to be determined)

## 3. Calibration and Setup

This chapter describes procedures for XD10 audio level adjustment, timecode reader sync adjustment, sound performance verification and fail-safe operation verification.

### 3.1. Equipment Requirements

Complete checkout and adjustment of the DTS XD10 requires, as a minimum, a good quality true RMS multimeter, an SPL meter, and the XD10's built-in test tones.

- ☑ **Note:** Lower quality voltmeters tend to become inaccurate at higher frequencies, such as the 1 kHz tone used for DTS playback calibration, and will result in incorrect calibration.

To verify or adjust the built-in audio setup tones, a DTS E313-00 output test board will be needed (obtain from DTS).

- ☑ **Note:** A complete “B-Chain” of the cinema processor (CP), including Room EQ, must be adjusted prior to calibration of the XD10.

### 3.2. Measuring and Adjusting XD10 Audio Levels

Channel setup tests and tones are pre-recorded onto the system hard drive. To use them, refer to the menu section for setting levels (Main menu | System Setup | Audio Setup | Level Adjustment).

**The audio playback level of the XD10's built-in 1kHz test tone has been preset at 300mV RMS when the output is set to 0.0 dB.** The reason it's set to 300 mV is that most cinema processors use this as their reference level. Consult the manual for your CP to determine the input buss level, or contact the manufacturer. Use the procedure below to verify that the XD10 is set to the correct output level or to make any necessary changes.

To verify or adjust the output level of each channel, follow this procedure.

- ☑ The XD10 must be ON. Refer to chapter 1, topic *Level Adjustment*, for details.

1. Connect the XD10 Analog Out cable from the XD10 to the DTS E313 test board.
2. Connect your multimeter's test leads to the E313.
3. Select Reference Tone from the Level Adjustment menu (Main menu | System Setup | Audio Setup | Level Adjustment). Press **ENTER**.

An adjustment screen for the first channel will display. The 1 kHz Reference Tone will begin to play on all channels and continue to play as you cycle through the adjustment screen for each channel.

<b>Adjust level for Ch 1 (Left) [ +00.0 dB ] Tone on all channels</b>	Press <b>▶</b> or <b>ENTER</b> to advance to the next channel. Press <b>▲</b> or <b>▼</b> to change level setting.
---	--

4. Set the multimeter for AC input at an appropriate range to measure a 300 mV signal. Use the multimeter to check the output level for each channel on the E313 board.

If the output is 300 mV ( $\pm 10$ ), press **▶** or **ENTER** to move on to the next channel.

If the output is NOT correct, or if your cinema processor requires an output level other than 300 mV, use the **▲** or **▼** buttons to adjust the level.

5. When finished, remove the E313 tester board (and store it for future use). Reconnect the audio cable from the XD10 to the CP.

### 3.2.1. Verifying Audio Levels

The pink noise tests that are built into the XD10 are used *only* to make A-B comparisons to an alternate sound source such as magnetic sound track or analog sound.

- Be aware that some external pink noise generator cards used on some cinema processors (such as CP65 and CP55, that do not have internal pink noise generators) may have a level discrepancy of as much as 1.5dB. For this reason the 1kHz test tone is used for setting the XD10 audio output levels.
- The XD10 must be ON. Refer to chapter 1, topic *Level Adjustment*, for details.

1. Select Pink Noise from the Level Adjustment menu (Main menu | System Setup | Audio Setup | Level Adjustment). Press **ENTER**.

An adjustment screen for the first channel will display. The XD10 will begin playing Pink Noise and the blue **DTS Playback** LED will light. The XD10 should automatically pulse the CP to the format used by DTS. The Pink Noise will begin playing on Ch-1 (Left) and will switch to the selected channel as you cycle through the channels.

<p><b>Adjust level for</b>  <b>Ch 1 (Left)</b>          [ +00.0 dB ]  <b>Pink Noise on Ch 1</b></p>	<p>Press <b>▶</b> or <b>ENTER</b> to advance to the next channel. Press <b>▲</b> or <b>▼</b> to change level setting.</p>
---	---

2. Open the screen curtains, set the CP level to reference (fader setting ‘7’ for most cases), go into the theater, and take SPL readings in the rear third and just off-center of the room. All amplifiers should be powered on and all speakers should be un-muted.

 **Caution:** Do NOT simply point the SPL meter out of the porthole window. This will not give you accurate SPL readings.

3. You may double-check the SPL settings using the table below. If you find a level discrepancy, first go back and verify the CP “B-chain” setup. Remember, the XD10 follows the CP and any level or EQ adjustment. Information on setting all appropriate levels is provided on the XD10 display. The XD10 levels may be readjusted to achieve the levels indicated in the table below.

 **Caution:** Pink Noise tests assume the CP levels are correct. If the CP levels are NOT correct, then adjusting the XD10 levels using the Pink Noise will mask a misalignment of the CP. Then if you later realign the CP properly, the XD10 levels will be wrong. To avoid this potential problem, be sure to align the CP’s B-chain first (set levels and adjust EQ).

Table 3-1. Pink Noise Level Adjustments

		<b>SPL</b>
1	Left channel	85dBC
2	Right channel	85dBC
3	Left surround	82dBC
4	Right surround	82dBC
5	Center channel	85dBC
6	Sub Bass channel, low passed w/DTS filter	91dBC
7	Left Center channel	85dBC
8	Right Center channel	85dBC
9	Back Surround (Coherent Acoustics configuration only)	82dBC
10	Aux (Coherent Acoustics configuration only)	82dBC

- Note:** SPL readings should be measured unweighted, or C weighted – slow response.

### 3.2.2. A Note about DTS Subwoofer Output

The XD10 subwoofer output level ranges from 20Hz to 120Hz (Coherent Acoustics format), up to 27dB above reference (85dB).

 Check your subwoofer's specifications to avoid damage to the speaker.

If a subwoofer is driven below its cutoff frequency, its driver(s) may become unloaded. When unloaded, the voice coil can travel outside of the magnet's gap, overheating and/or causing mechanical damage to the speaker. A high pass filter should be installed on speakers with high cutoff frequencies. Contact your speaker manufacturer for more information.

### 3.2.3. Mono Surround

The mono surround output is a mix of the left and right surround signals. This "mono" signal is available ONLY on the mono surround output pin (pin 21) on the XD10's ANALOG OUT (CH 1-10) connector.

1. In theaters with only mono surrounds, select the left surround pink noise and adjust for 76 dBC SPL in the theater. Note the level displayed on the XD10 screen.
2. Next, select right surround pink noise and adjust the output to the SAME level that the left surround was adjusted to. The level in the theater should be the same, 76 dBC SPL, as when playing back pink noise on the left surround channel.

Any future adjustment of the surround levels should be made to both the left and right surrounds equally to maintain the correct balance of the original stereo surround mix.

## 3.3. Timecode Reader Sync Adjustment

This adjustment is easily performed using the numbered leader in front of the DTS Demo Reel. (The demo reel is supplied with the *DTS Technician's Kit*, which can be purchased from any DTS dealer.) See the steps (below on this page).

Additional drawings can be viewed in Appendix B (*Installation Diagrams*) of this manual.

If you do not have a demo reel, the delay can be calculated by counting the number of picture frames from the DTS reader head red LED (lens) to the projector's picture ("film") aperture. Multiply the result by 1.25 and subtract 1. Round the resulting number to the closest ¼ (0.25). Set the OFFSET value in the XD10 System Setup | TC RDR Offset menu to this number.

Example:      27 frames x 1.25 = 33.75  
                   33.75 - 1 = 32.75  
                   Set the OFFSET to 32.75

**Remember:** When using the counting frames method, frames are counted from the timecode reader lens to the picture aperture. And the first frame, the frame at the lens, is counted as zero (0) – NOT as 1.

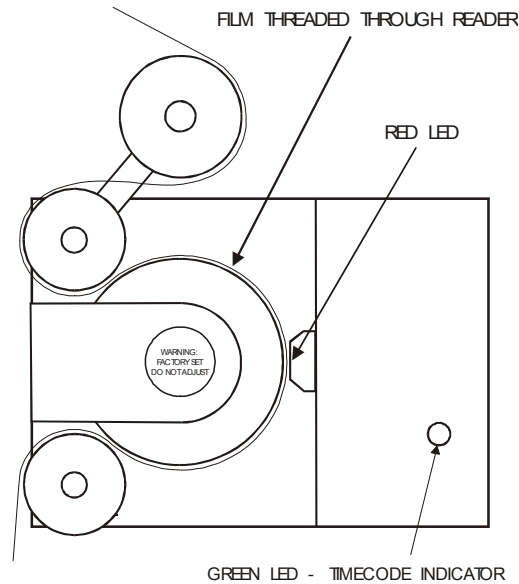

Figure 3-1. Timecode Reader Head, Threading

### Procedure using Demo Reel

The Demo Reel has a specially printed leader for setting the timecode head offset.

1. Using the numbered leader, put the start mark **00** at the reader's lens (red LED) and thread the film through the projector as normal.
2. After threading, look at the film and read the number at the projector's sound head. This is the OFFSET value and that number should be entered into the XD10 Setup | Timecode Offset menu.

**⚠ Important:** Make the same size film loops inside the projector when measuring offset as when running a movie. Failure to do so will result in improper sync when the movie runs in DTS Digital mode. **For two-projector houses**, the reader at each projector must have the same OFFSET value (must have equal distance from the aperture), since there is only one setting for the system (not two).

## 3.4. Verifying Operation

### 3.4.1. Verify Sound Performance

3. Thread the DTS Demo reel through the projector and DTS reader. Be sure the XD10 is fully booted and ready to play.
4. Start the projector. Verify the DTS-XD10 automatically switches the cinema processor to the (DTS) Digital format. Verify sound is heard in the monitor speaker and pop open the porthole (if possible) to verify sound is heard in the auditorium.
5. While still in the booth, verify the XD10 DTS Playback LED (blue) is lighted and that the LCD screen displays the film title, Serial number, Reel number, and running timecode.



Figure 3-2. XD10 LCD screen (typical)

6. Go into the theater while the Demo reel is playing. Verify sound is in-sync, sounds well balanced and has overall good digital sound quality.

If levels sound unbalanced, check the cinema processor's output levels. Then be sure that the XD10 output of 300mV RMS on all channels matches the input reference level of your cinema processor.

 The XD10 MUST match the cinema processor's input reference level. (The input reference level of your cinema processor should be indicated in its manual or consult the manufacturer.)

7. If a two-projector theater, repeat this procedure for Projector 2.

### 3.4.2. Check Automatic Fail-Safe (Default) Operation

This procedure will verify that, should the DTS timecode reader fail for any reason, the system will automatically switch to optical sound format.

1. While the demo film is running, block the timecode at the reader or unplug the 9-pin connector at the reader.

To block the timecode reader, insert a business card between the film and the lens of the timecode reader head and keep it there for at least six seconds.

2. Verify that after 4 to 5 seconds of not seeing timecode, the DTS-XD10 switches to the SR optical sound format.

There should not be a dramatic sound level difference when the cinema processor switches from digital to analog during **dialogue scenes**.

If there is a dramatic difference, check the cinema processor's levels (A- and B-chains) first and then test again.

 Remember, the XD10 output level must match the cinema processor's input reference level.

3. Now, restore timecode and XD10 should automatically switch the cinema processor to the digital format after about two seconds.
4. If a two-projector theater, repeat this procedure for Projector 2.







## 4. Specifications

### 4.1. Inputs

#### Time code (Projector 1 and Projector 2)

DTS specific connections

Connectors: Rear Panel DB9M

Power (+5V) and Return for DTS reader head

DTS

SMPTE (25, 29.97, 30 ndf)

- Note:** Theater uses 30fnd referenced to video (29.97) and D-Cinema uses 24 frame referenced to video (23.976)

Timecode signal (DTS and SMPTE formats), “standard DTS timecode signal captive range 1.X-5V”

#### Automation

Connector: Rear Panel DB25F

8 “format” (switch closure) inputs or outputs, 24V max, optically isolated

7-pin Phoenix<sup>®</sup> connector for 3 additional closures

### 4.2. Audio Outputs

#### Analog (Main)

Connectors: Rear Panel DB25M Channels 1- 10

Option for additional 10 Channels on additional DB25M

Output Impedance: 100 ohm (load > 600 ohms)

Output Level: unbalanced 300 mV

Frequency Response (THX Matrix 40-15 k to -3db @ Ref.)

Dynamic Range: 96dB, 20 – 20 kHz, unweighted

S/N: >80dB @ -20dBFS (per THX)

Crosstalk: -60 dB, 20 – 20 kHz

Table 4-1. Analog Output Channel Assignments

Channel Number	Coherent Acoustics
1 (DB25) A	Left
2 A	Right
3 A	Left Surr
4 A	Right Surr
5 A	Center
6 A	Sub
7 A	Left Center
8 A	Right Center
9 A	TBD
10 A	TBD

**Analog (Narr and Aux)**

Designed to support Descriptive Narrative (only available with CSS option?)

Connectors: two Rear panel RCA

Output Impedance: 10 K ohms

Output Level: 300 mV +/- 10 mV

Dynamic Range: 90dB, 20 – 20 kHz, unweighted

S/N: 85dB

THD+N: 0.03%, 20 – 20 kHz

Crosstalk: -45 dB, 20 – 20 kHz

**Digital Audio Out**

Connector: Rear Panel DB25M,

Electrical Format: AES/EBU (AES3-1992)

Coding Format: S/PDIF, AES/EBU

Sample Rates: 44.1, 48, 88.2, 96 kHz

Word Widths: 16 and 24 bits

Copy Protection: Ignored

Channel Status and User Status: Unused?

**Frequency Response**

L, R, C, L-C, R-C: 20 Hz to 20 kHz

LS, RS: 80Hz to 20 kHz

Sub: 20Hz to 80 Hz

**Coherent Acoustics**

L, R, C, L-C, R-C: 20 Hz to 20 kHz

LS, RS 9, 10: 20 Hz to 20 kHz

Sub: 20 Hz to 120 Hz

**4.3. Other Connectors****EMA Control Outputs**

Rear Panel DB15F; connections for power, fan sensor, douser control to EMA (for subtitle projector option)

**Cinema Processor Automation Outputs**

Rear Panel DB25F

**Ethernet (for future features)**

Rear Panel RJ45

Conforms to IEEE 802.3

**USB (for future features)**

2 Rear Panel USB-A

1 Front Panel USB-A

**RS-232 (for Rear Window)**

Rear Panel DB9M COM1

RS-232 electrical and software

Hardware and Software (XON/XOFF) flow control

Supported baud rates: 4.8 – 56.2 Kbaud



## **Projector Video Out**

VGA Out

Rear Panel HP15F

Support CSP Subtitle Projector option

Optional Video (for Pre-show)

The added board scales the video output to the projector resolution (up to 1024 x 768)

Coherent Acoustics and PCM48/24

If subtitling and pre-show video are both set up in an XD10, the video's resolution will be that of the signal going to the CSP projector. However, only one of the two outputs (subtitling and pre-show) can be operating at a given time. They do not operate simultaneously.

## **4.4. DVD ROM Drives**

Two (2) DVD-ROM drives are provided in the system. The drives spin down (stop spinning) automatically when file downloading is complete.

12X DVD-ROM playback

40X CD-ROM playback

Random access; 90 ms

MTBF 100,000 Power On Hours

## **4.5. Hard Drive**

Capacity: 40 GB

Average Seek (Read): 8.9ms

Average Seek (Write): 10.9ms

Full Stroke Seek: 21ms, typical

MTBF 100,000 operational hours



## 4.6. User Interface

### 4.6.1. Status LEDs (Front Panel)

#### LCD (Front Panel)

A 4 line X 20 character, backlit LCD

Backlight not adjustable. Viewing angle adjustment via trim pot through front panel.

#### Dimensions:

HWD 5.25 X 19.0 X 15.0 (3U 19" rack-mount standard)

#### Weight

20 lbs., shipping weight

#### Environmental

This product will be used in exhibitor projection booth environments. It must withstand warm ambient environments and comply with all necessary regulatory requirements for commercial use.

Table 4-2. Operating Conditions and Reliability

Parameter	Conditions	Min	Nominal	Max	Unit
Low line voltage		85	100/120	135	V
High line voltage		200	220/240	270	V
Line Frequency	Low line =60 / High line = 50	47	60/50	63	Hz
Input cooling airflow	Fan is internal to supply	3.5			CFM
Operating ambient temperature range	At 0 ft elevation	0		40	°C
Operating ambient elevation range	At 35 °C	0		10,000	Ft
Storage temperature range		-20		+70	°C
Operating humidity range	Non-condensing	10/10		95/70	%°C
Storage elevation range	2000 ft/min max rate to climb	0		20	Kft

## 4.7. Regulatory – Safety, Emissions, and Susceptibility Specifications

Table 4-3. Regulatory, Safety, EMI/EMC

Safety	UL950 (USA) ( <b>NOTE: THX requires U813</b> ) CSA 22.2 NO.950.95 3 <sup>rd</sup> edition (USA) c-UL (Canada) TUV (Europe): EN60950: 1992+A1+A2; 1993+ A3; 1995+A4; 1997 (includes proof of low voltage directive) (EC) NOM (Mexico): NOM-001-SCFI-1993
Radiated and conducted Emissions	FCC par15, subpart B, (USA) Class A limits EN 55022 (1998) (EU) ICES-003 (Canada) C-Tick Mark (Australia) GOST (Russia) CCIB (China)
Harmonic Current Emissions	EN 61000-3-2
Voltage Flicker	EN 61000-3-3
Power Factor Correction	Ref. IEC 1000-3-2
Required Regulatory Marks	FCC- Class A CE ICES-003 C-Tick NOM TUV GS UL & CUL CSA CB IRAM GOST CCIB MIC Mark – Korea

### Patents

The DTS system has been granted the following patents:

United States of America Patent Nos. 5155510, 86/9588, 5450146, 5751398

Australia Patent Nos. 652965, 661614

Canada Patent No. 2016028

Europe Patent Nos. 0551424, 0615634, 0473677, 0632922, 0666495

France patent Nos. 8906807, 9114963

India Patent No. 181427

Korea Patent Nos. 153028, 0185423

Japan Patent Nos. 2033555, 2708961

Russia Patent No. 2088962

## 4.8. XD10 Block Diagrams

The basic system provides 10 audio channels, 2 auxiliary channels, two DVD/CD drives and an internal hard drive. Downloadable CSS software allows the XD10 to be used with subtitles.

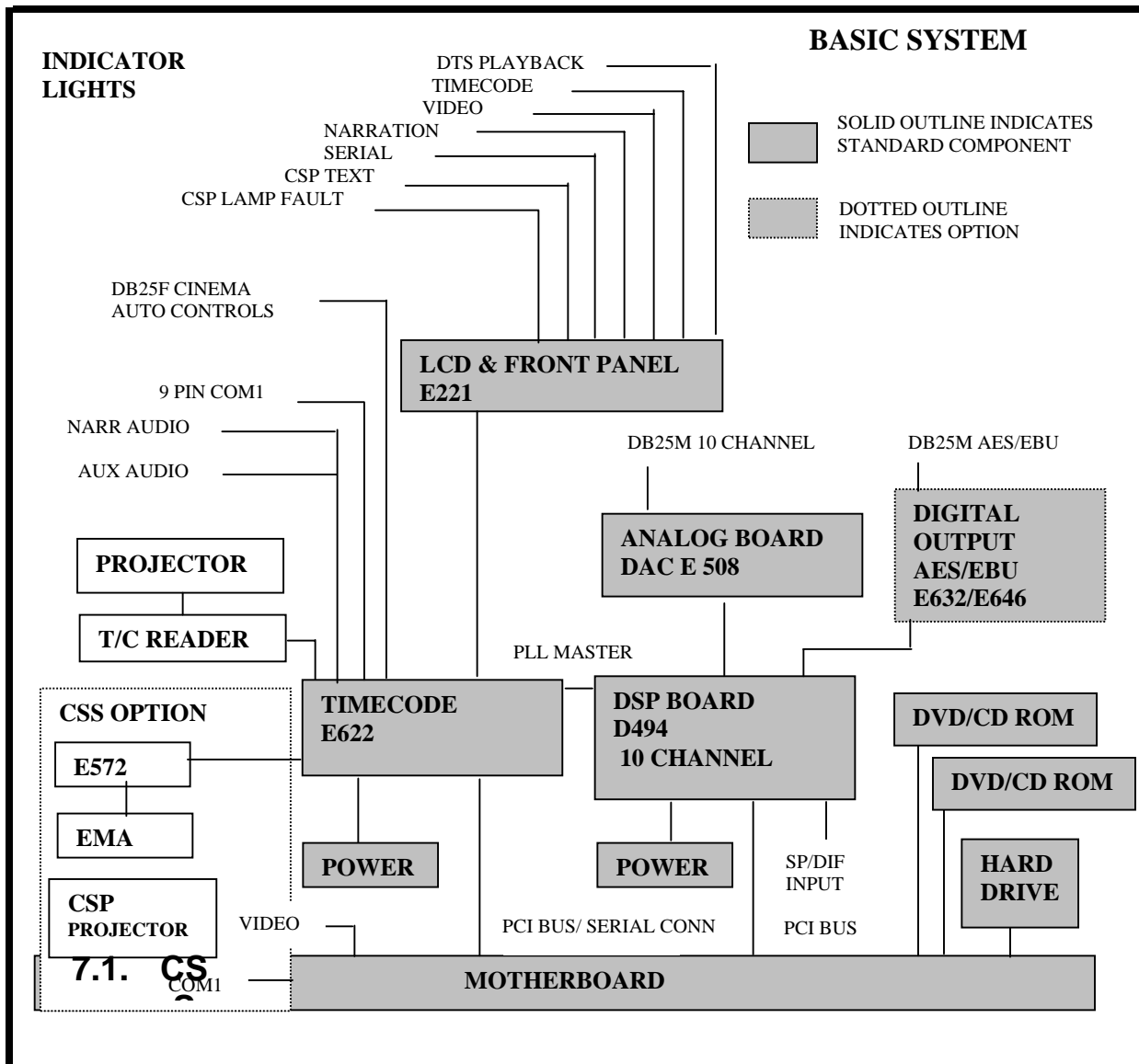

Figure 4-1. Block Diagram, Basic System

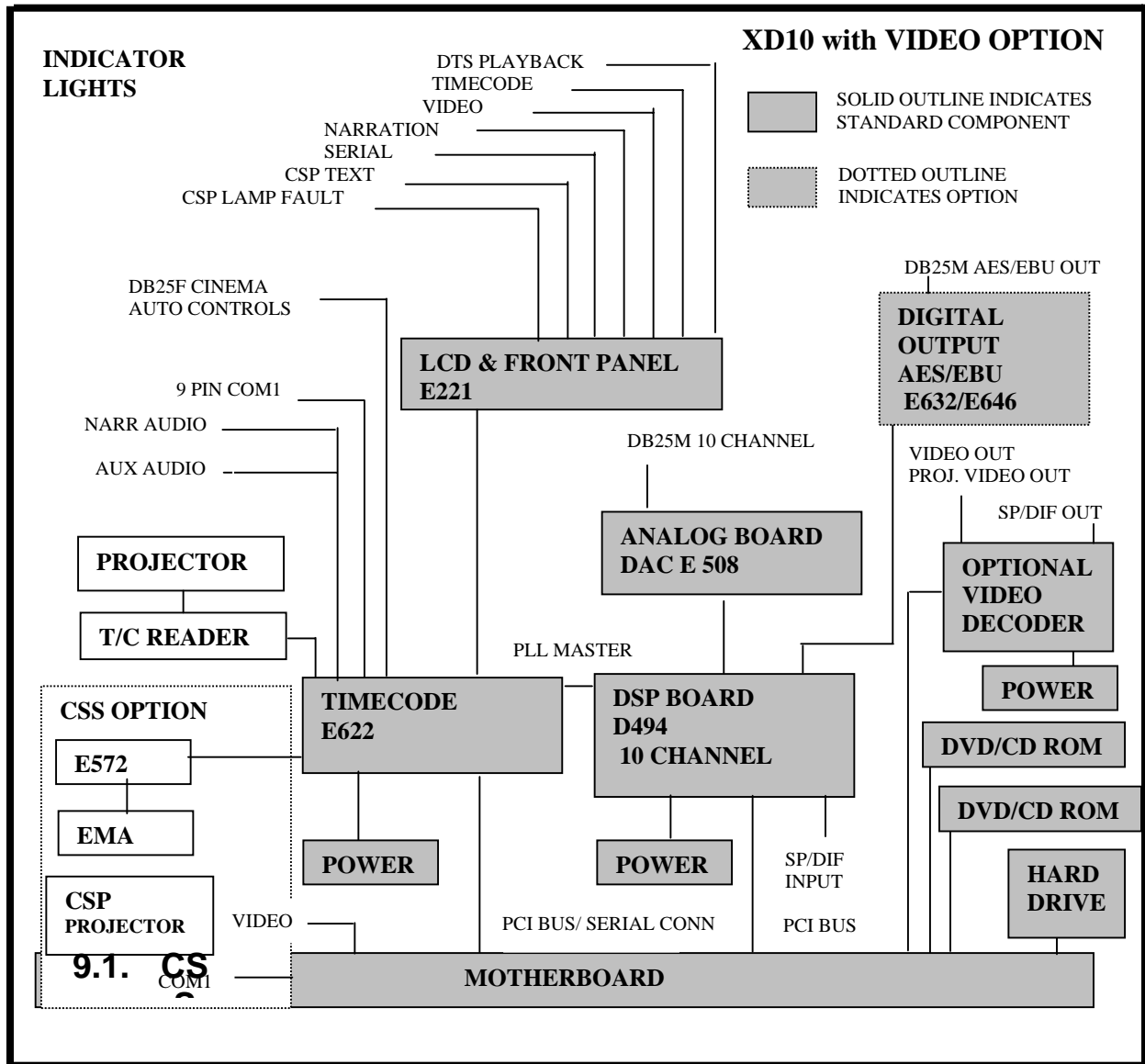
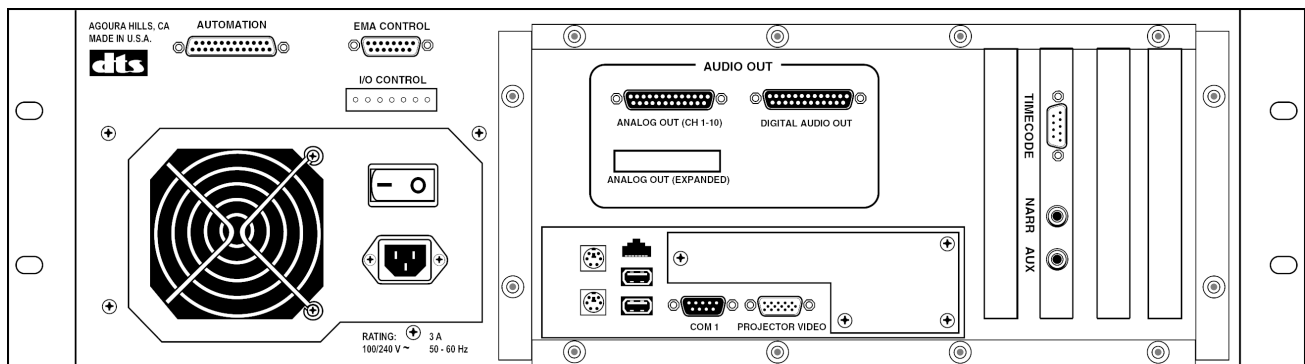
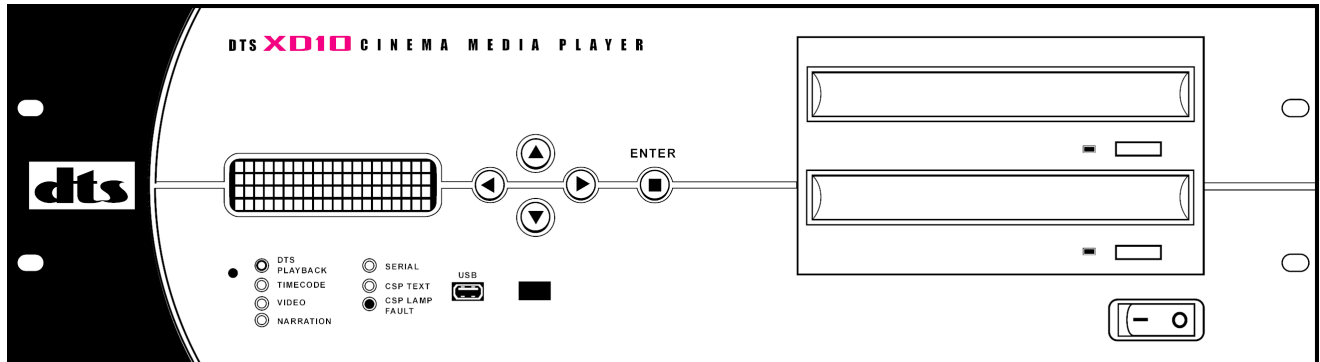

Figure 4-2. Block Diagram, Video Option added





## 5. XD10 Maintenance and Troubleshooting



### 5.1. Routine Maintenance

Use compressed air to blow off the Timecode Reader's optics (lens) once **every day** to remove dust.

Using a DVD cleaning disc, the DVD drives should be cleaned **every six months**, or as needed.

The Timecode Reader head's voltage should be checked and recalibrated **after three months** service, and then every six months thereafter. For details, see DTS Technical Note *Reader Head LED Voltage Calibration*, TN-E550. (TN-E550 is included in this manual, in Appendix H *Technical Notes*.) You may obtain a copy from DTS Cinema Technical Support via e-mail at [cinematech@dtsonline.com](mailto:cinematech@dtsonline.com).

### 5.2. XD10 Troubleshooting Tips

It's always a good idea to stand in the theater and listen to the first few minutes of the movie. Listen to the sound level and general quality of the sound. The sound track should be in sync with the picture (wait for a dialogue scene) and played at a comfortable level. Even though not every scene will have surround material, do your best to listen for the surround speakers. Most opening musical sequences contain surround information. To adjust the overall sound level in the theater, adjust the main fader on the cinema processor.

 Be sure the soundtrack was loaded for the film you are playing. Feel free to contact DTS Post Production for help.

#### 5.2.1. I have a DTS print but I don't have discs

Contact your film distributor and ask for the disc(s). Remember a film that runs less than 90 minutes will have only one movie disc – which should also be labeled “**one disc only**”. Movies running over 90

minutes will have two discs. Occasionally, longer movies will have additional discs and special show instructions. Also check the hard drive to see if the movie soundtrack has been previously loaded.

### 5.2.2. Film not in sync or doesn't sound right

Turn off the DTS-XD10 unit. Listen and verify that the movie is playing in optical format. Let the film finish playing in optical. **Do not attempt to remedy these problems while playing in DTS.** The theater technician should perform a full DTS quality check. (See chapter 3, *Calibration and Setup*, for details.)

### 5.2.3. Volume too loud

Turn down the fader pot on the cinema processor. Do not adjust the DTS-XD10 audio level from the menu controls. If sound level needs adjustment after switching to digital, contact your theater technician.

### 5.2.4. DTS-XD10 won't switch into digital sound

Verify that movie information is loaded on to the hard drive in the DTS-XD10 unit. If the film sound is not loaded into the hard drive, you must obtain the right discs and load them before you can play in the digital format. Verify that the movie discs match the movie.

If the unit does not switch to digital, verify that the green LED on the projector timecode reader head is glowing brightly and steadily while the movie is running. If the LED is dark, check to make sure that the film is threaded correctly through the DTS Timecode Reader and that the film has a timecode strip (located between picture and analog sound tracks). If no timecode (dots & dashes) strip is seen, call the film distributor and request a DTS print.

### 5.2.5. DTS XD10 switches out of DTS Digital

If the DTS-XD10 does not see timecode for four seconds, the sound should automatically default to optical. Verify that the green LED on the DTS Timecode Reader head is glowing brightly and steadily while the film is running.

If the TIMECODE LED on the DTS-XD10 or reader head is blinking, gently squeeze the film between two fingers as it exits the reader head. Do the same at the entrance of the reader. If the LED stops blinking and maintains a steady glow, this indicates that you need to add more tension. Tension is added by repositioning the auxiliary flanged roller as close as possible to the largest roller so that it has maximum contact with the film. You may also add an additional roller to the output of the reader. Verify that all the gears in the projector are in good condition.

Use compressed air to blow off the lens on the reader head, but **never adjust the lens.**

Be sure your reader head is adjusted to 4 VDC. (See TN-E550 in Appendix H.)

Attach the grounding jumper on the timecode cable to the projector. This is most easily accomplished by attaching the screw that secures the timecode cable to the reader head. Verify with an ohmmeter that the reader's housing is electrically connected to the projector housing.

If the drop-out repeatedly occurs at the same place(s) in the movie, replace the reel(s).

 Do not put any sound format cues on film within timecode. Do not use leader with timecode elsewhere as it will cause a false start on the player.

As a last resort, force the unit to play in optical mode. Turn off the DTS XD10 and verify that the cinema processor switches to optical. If it does not, adjust manually. Contact your DTS Theater Technician.

### 5.2.6. What do I do with the discs when the movie has finished its run?

Simply return the movie discs with the film to the depot. Put the discs in the disc carrier and place it into the film can.



## 5.3. Guide For A Seamless Change-Over

Occasionally, when running a DTS movie with dual projectors, you may come across situations when the picture and sound are not changing in unison during a change over. This is due to the fact that as soon as the first frame of action reaches the picture aperture on the incoming projector, the DTS digital sound will change over to that reel. DTS digital sound changes independent of the projector's douser position. Change over anomalies are most evident on movies that have very tight editing / scene change tolerances from one reel's end to the next reel's start.

When this occurs, perform one of the adjustment procedures below.

### 5.3.1. Sound changes before picture

When threading the incoming projector, roll down the film to a greater number of feet. If you normally thread to "8", try threading to "9" or "10". Keep adjusting the roll down setting until the picture changes with the sound. Also, try hesitating a second before starting the incoming projector on the first cue.

### 5.3.2. Picture changes before sound

When threading the incoming projector, roll down the film to a lesser number of feet. If you normally thread to "8", try threading to "7" or "6". Keep adjusting the roll down setting until the picture changes with the sound. Be sure to hesitate opening the douser on the incoming projector (on the second cue) until the last word on the outgoing reel is heard on screen.

### 5.3.3. Determining roll-down

Adjusting the roll down setting is a judgment call. Base it on the time delay of picture vs. sound. One second of delay equates to 24 frames, or 1.5 feet.

## 5.4. Inside the DTS XD10

Refer to Figures 5-1 and 5-2 (pages 5-5 and 5-6) for location of components within the XD10 chassis.

### 5.4.1. Timecode Board

The Timecode board (E622) contains the timecode head offset information and these connectors:

- the serial connection to the Front Panel containing the LCD display and 7 system status LEDs
- a 9-pin timecode cable output D-type connector
- two auxiliary audio outputs, RCA-type connectors
- a 7 pin Phoenix® connector and DB25F for Cinema automation control

The OFFSET is set in the software according to the timecode reader location. This setting is different depending on type of projector or location of the timecode reader. See *Timecode Reader Sync Adjustment*, in chapter 3, for instructions to determine the OFFSET setting.

**The status LEDs on the front panel include:**

Table 1. Front Panel LED Indicators

LED	Color	Indication
DTS PLAYBACK	Blue	Outgoing signal / digital signal
TIMECODE	Green	Incoming Timecode data
VIDEO	Green	Transmitting Intermission program, or other audio/video material
NARRATION	Green	Outputting narration
SERIAL	Green	Serial data output / Rear Window captions
CSP TEXT	Green	CSS subtitles
CSP LAMP	Red	If flashing, replace CSS projector lamp.
FAULT		Solid light indicates lamp failure.

A circuit breaker protects the power going to the Timecode Reader head (through the 9-pin connector) against short circuits. The breaker is self-resetting so replacement is unnecessary.

The 9-pin connector (accessed on the DTS-XD10 rear panel) is used to connect the timecode cable to the timecode reader on the projector.

### 5.4.2. Power Supply

This unit supplies power to the DTS-XD10 Player. This supply is switchable between 110 VAC and 220 VAC and adjusts automatically.

The cooling fan in the power supply should be rotating when power is applied.

 To prevent dirt from being pulled into the DVD/CD-ROM drives, do not block the ventilation holes at the side of the DTS-XD10 player.

### 5.4.3. DVD/CD-ROM Drives

There are two DVD/CD-ROM drives in the DTS-XD10. The two are identical, except for the way jumpers are installed. The top drive (A) is jumpered to be “master” and the bottom drive (B) is jumpered to be “slave”.

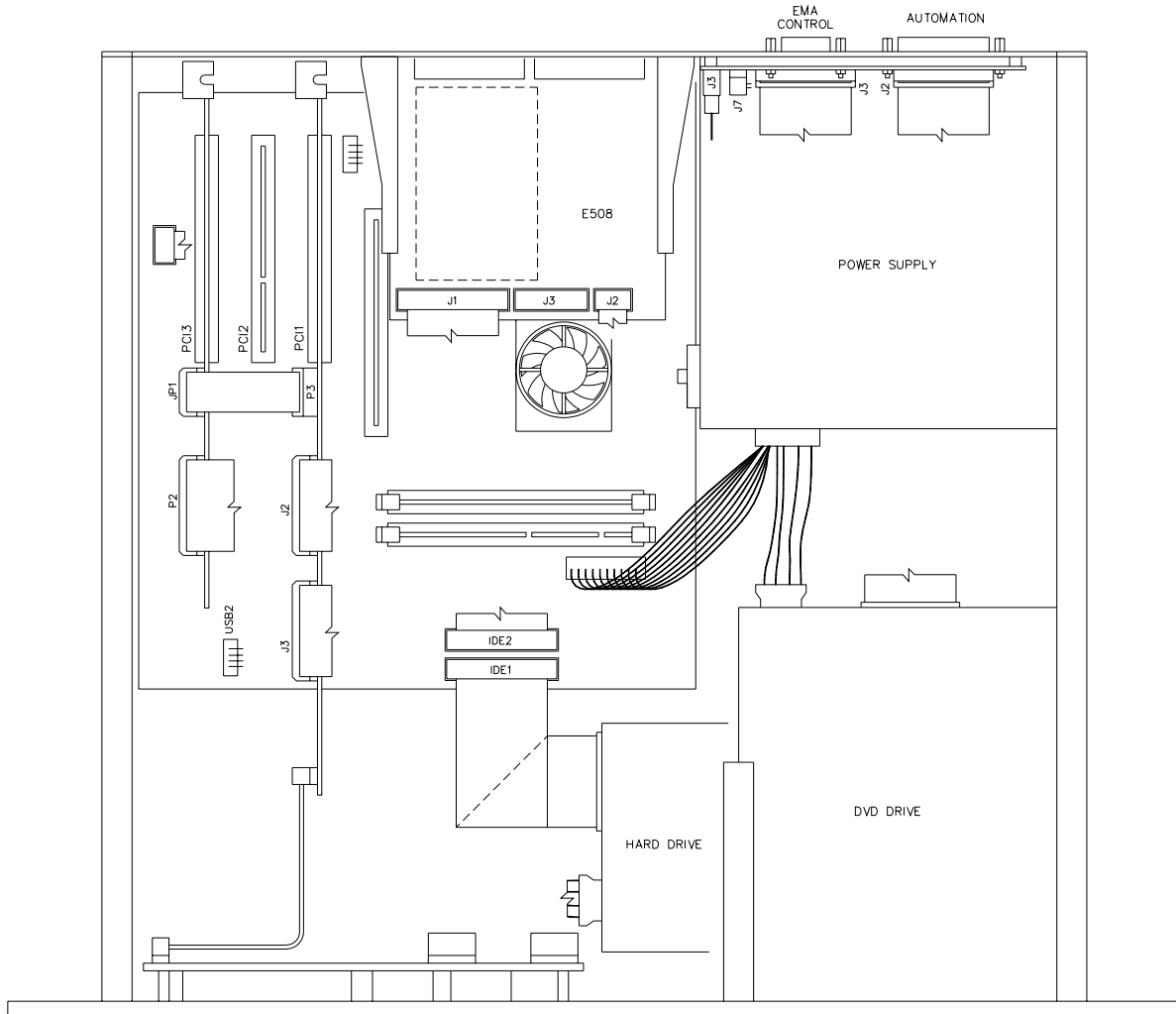

Figure 5-1. XD10 Top View

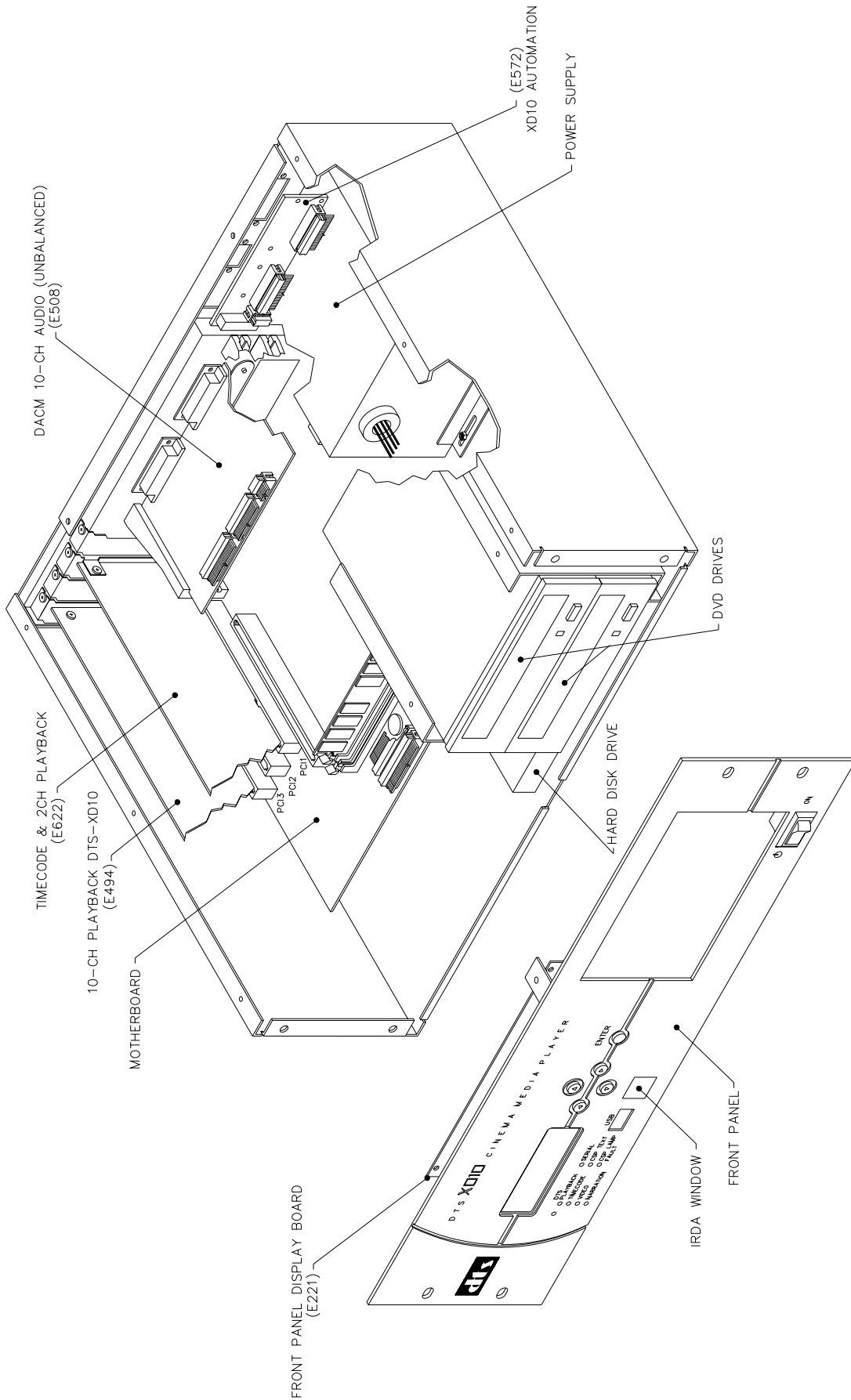

Figure 5-2. XD10 Cutaway View



## Appendix A. DTS XD10 System Parts List

- Note: There are 11 different configurations for XD10 installations, depending on cinema processor interface, cable length, and whether single or dual projectors.

### A.1. XD10 Master Parts List

Part Number	Description
2501 0001-00	Power cord, straight, detachable, standard (bare-ended available, call DTS)
2501 0002-00	Power cord, right angle, detachable
MD10 D600-00	Timecode reader head, 35mm, auxiliary roller attached
9005 E108-00	Auxiliary roller assembly kit, 35mm
9003 E119-00	Screw kit, rack, oval hd screw and washer
<b>Timecode Cable for single projectors</b>	
9022 D435-01	30 ft. Timecode cable, standard
9022 D435-02	40 ft. Timecode cable
9021 D435-05	45 ft. Timecode cable
9021 D435-06	60 ft. Timecode cable
<b>Timecode Cable for dual projectors</b>	
9021 D435-04	Timecode Y cable, 30 ft. / 40 ft.
9021 D435-21	Timecode Y cable, 30 ft. / 30 ft. standard
9021 D435-23	Timecode Y cable, 40 ft. / 50 ft.
9021 D435-26	Timecode Y cable, 60 ft. / 60 ft.
<b>Mounting brackets (to projector) for 35mm timecode reader heads (hardware included)</b>	
5006-0001-00	Cinemeccanica bracket (use with D614 standard bracket)
9003 E100-00	Screw kit, bracket, standard
9003 E102-00	70mm spacer kit (used to fit a 35mm reader in a 70mm space)
9061 D614-00	Projector bracket, 35mm standard (for Century, Simplex, Ballantyne)
9061 D615-00	Universal bracket
9061 D616-00	Phillips AA bracket (Norelco)
9061 D617-00	"L" bracket (Kinton)
9061 D622-00	Front mount bracket (use with Dolby SR-D or Sony SDDS readers)
<b>Mounting brackets, switchable 35mm / 70 mm timecode reader heads (hardware included)</b>	
9061 D625-00	35mm/70mm standard bracket used with breakaway plates
9061 D626-00	Breakaway (spacing block) plates for 35mm DTS reader head
9061 D627-00	Breakaway (spacing block) plates for 70mm DTS reader head
9061 D628-00	Adapter panel for D617 "L" bracket (so breakaway plates can be used)
<b>Publicity supplies and film</b>	
6800 0735-00	Film, DTS Trailer, sonic landscape, flat (qty 2)
6800 0735-01	Film, DTS Trailer, sonic landscape, scope (qty 2)
7004 0001-01	4 inch DTS Panel Marquee
7004 0001-02	8 inch DTS Panel Marquee
<b>Cables and Breakout Boards (for connecting to cinema processor)</b>	
2503 0014-00	Cable Assy, 25-pin "D" M/F, 6 ft long for DTS-6AD, DTS-ECP, CP65, UltraStereo JS series, Panastereo CSP1200
2503 0017-00	Cable Assy, 25-pin "D" M/M 6 ft long for DTS-6AD or DTS-ECP
9022 E173-00	Cable Assy, fem"D" pin, 2 inches long for CP65
9022 E680-00	Cable Assy, XD10 to CP45 Audio
9022 E681-00	Cable Assy, Automation, XD10/DTS-6D Translation for CP45, CP65 and UltraStereo JS series
9022 E682-00B	Cable Assy, XD10 Automation Adapter for CP500/650
9022 E683-00	Cable Assy, DX10 to CP500/650 Audio
9022 E684-00	Cable Assy, XD10 to CP65/SRD Audio
9022 E709-00	Cable Assy, XD10 to Smart Mod VI



9022 E720-00	Cable Assy, XD10 to DFP-D3000 Audio
9022 E721-00	Cable Assy, XD10 to DFP-D3000 Automation
9022 E724-00	Cable Assy, XD10 to CSP1200 Automation (Panastereo)
9030 D564-00	Breakout board PCA, DTS-6D to CP-55 Logic Interface (for CP65)
9030 D571-00	Breakout board PCA, DTS-6D to UltraStereo Logic Interface
9030 D574-00	Breakout board PCA, DTS-6D to CP-65 Audio Interface
9030 D575-00	Breakout board PCA, DTS-6D to UltraStereo Audio Interface
9030 D716-00	Breakout board PCA, DTS-6D to CP45 Logic Interface
9030 D725-00	Dual input interface board, studio application (DTS XD10-CP65-dubber)
<b>CSP Subtitling Projector (option)</b>	
MD10 DCSP-00	Projector for throws up to 50 feet, standard “short throw”
MD10 DCSP-1	Projector for throws up to 120 feet, “long throw”
2503002800	Projector Video Cable, SVGA 15-pin HD shielded with ferrite beads on each end, 25 ft. (standard)
2503002801	Projector Video Cable, SVGA 15-pin HD shielded with ferrite beads on each end, 50 ft.
<b>EMA External Masking Apparatus: (for Subtitling Projector)</b>	
MD00 DEMA-02	Short throw DTS-EMA
MD00 DEMA-03	Long throw DTS-EMA
9120 E573-01D	Bracket 16 inches long (40.60 cm)
5005 0003-00	Arm, 6” long (15.94 cm)
5005 0004-00	Arm, 12” long (30.48 cm)
5005 0005-00	Arm, 18” long (45.72 cm)
9120 E610-00B	Wall Mounting Plate (fasteners not included – obtain locally)
1007 M601 00	Thumb screw (on wall mounting plate)
<b>Audio Output Testing</b>	
9030E31300A	DTS tester board, for testing outputs at the XD10 Analog Output connector

## A.2. Replacement Parts

Part Number	Description
<b>Subtitles projector</b>	
1802 0001 00	Lamp Module
<b>EMA External Masking Apparatus</b>	
9020 E656 00	Light electronic shutter assembly
9022 E655 00	Fan assembly, wire assembly included
9020 E472 02	Large Magnetic Trim for mask, 3.16” x 6.7”
9020 E472 01	Medium Magnetic Trim for mask, 1.96” x 6.7”
9020 E472 00	Small Magnetic Trim for mask, 1.17” x 6.7”
<b>Timecode Readers</b>	
MD10 D600-00	Timecode reader head, 35mm, auxiliary roller attached
9005 E108-00	Auxiliary roller assembly kit, 35mm
MD10 D600-02	DTS Timecode Reader Head, 70mm
9005 E163-00	Auxiliary Roller, 70mm



## Appendix B. Installation Diagrams

The diagrams on the following pages cover most installations of XD10, Timecode Reader heads and EMAs. Contact DTS if the system you are installing requires additional information.

### B.1. Interconnect Diagrams: XD10 to Cinema Processor

This section contains the following interconnect diagrams, in numerical order by drawing number:

Drawing Number	Revision	Title
D435	0	Time Code Reader Cable
E680	0	Cable Assy, Audio XD10 to CP45
E681	0	Cable Assy, Automation, XD10/DTS-6D Translation
E682	B	Cable Assy, XD10 to CP650, CP500 and CP65 Automation
E683	A	Cable Assy, XD10 to CP650, CP500 Audio
E684	0	Cable Assy, XD10 to CP65/SRD Audio
E694	A	XD10-CP650 Interface
E699	A	XD10-CP500 Interface
E700	0	XD10-CP65 Interface
E701	0	XD10-65-DA Interface
E706	0	Ultra*Stereo JS series Interface
E709	0	Cable Assy, XD10 to Smart Mod VI
E720	0	Cable Assy, XD10 to DFP-D3000 Analog
E721	A	Cable Assy, XD10 to DFP-D3000 Fallback Automation
E722	0	XD10 to DFP-D3000, Interface
E724	0	Cable Assy, XD10 to Panastereo CSP 1200 Automation
E726	0	XD10 to DTS 6AD or DTS-ECP Cabling
E727	0	XD10 to Panastereo CSP1200 Interface
E728	0	XD10 to CP45 Interface
E730	0	XD10 to Smart MOD VI/VII Cabling
E732	0	XD10 to CP200 w/CAT 160, Interface
E733	0	XD10 to CD200 w/SRD and CAT 560, Interface
E734	0	XD10 to CD55 Mono Surround, Interface
E735	0	XD10 to CP55 Stereo Surround, Interface
E742	0	XD10 to CP200 w/CAT 560, Interface



## B.2. Brackets for the DTS Timecode Reader Head, 35mm and 70mm

- **D614 - Standard Bracket (35mm only)** – cannot be used with breakaway plates

For projectors: Century, Simplex, and Cinemeccanica with Kelmar bracket (below). Intended to fit between the projector and reel arm. We have produced the bracket with the American standard size hole to accommodate 2 inch center spacing 3/8 - 16 tap, that is utilized to mount the American-made upper reel arms. Comes with the following hardware:

Qty	Description
2	10 x 24 x 1/2" long screw
2	3/4 x 16 x 1" long hex bolt nut
2	3/8" lock washer

- **D615 - DP70 Universal Bracket (35mm only)**

Used for American projectors with a penthouse. Comes with tap and drill bit 8-32, and the following hardware:

Qty	Description
2	10 x 24 x 1/2 in. long screw
2	3/4 x 16 x 1 in. long hex bolt nut
2	3/8 in. lock washer

- **D616 - AA2 bracket (35mm only)**

For Norelco AA projectors. Comes with the following hardware:

Qty	Description
2	#10 lock washers
3	5/16 in. x 18 x 5 in. long screws
3	3/8 in. split ring lock
2	10 x 24 x 1/2 in. long screw

- **D617 - DP75 Bracket (35mm only)**

Used to mount the DTS timecode reader head to the side of the projector. Comes with same hardware as the D614. See also D628 - "L" adapter panel, below.

- **D622 - Front Mount Bracket (35mm only)**

Used when installing multiple digital sound heads or when there is not enough room to lift the projector arm. Used with Dolby SR-D™ and Sony SDDS™ reader heads.

- **D625 - 35mm / 70mm Standard Bracket – used with breakaway plates.**

For projectors: Century, Simplex, and Cinemeccanica with Kelmar bracket (see below). Intended to fit between the projector and reel arm. We have produced the bracket with the American standard size hole to accommodate 2" center spacing 3/8 - 16 tap, that is utilized to mount the American made upper reel arms. Comes with the following hardware:

Head	Qty	Description
35mm	2	10 x 24 x 1/2 in. long screw
35mm	2	3/4 x 16 x 1 in. long hex bolt nut
35mm / 70mm	2	3/8 in. lock washer
70mm	2	3/8 x 1-1/2 in. long cap screws
70mm	2	3/8 in. flat washers
70mm	2	3/8 in. hex nuts

- **D626 - Spacer Breakaway Plate** – used to mount 35mm DTS reader to 35/70 brackets
- **D627 - Spacer Breakaway Plate** – used to mount 70mm DTS readers to 35/70 brackets
- **D628 - “L” adapter panel (35mm / 70mm)** – used with D617 and breakaway plates

Used to mount the DTS timecode reader head to the side of the projector. Comes with same hardware as the D614. D628 is used to adapt the D617 for use with the breakaway plates (D628 attaches to D617).

- **5006 0001 00 - Cinemeccanica Bracket / adapter plate (35mm only)**

For Cinemeccanica projectors. Must be used with the D164 standard bracket for mounting the DTS timecode reader head. If the reel arm needs to be remounted, two plates are required.

**Note:** Cinemeccanica also provides their own brackets. Contact them directly.

### DTS Reader Standard Mounting Brackets (next 3 pages)

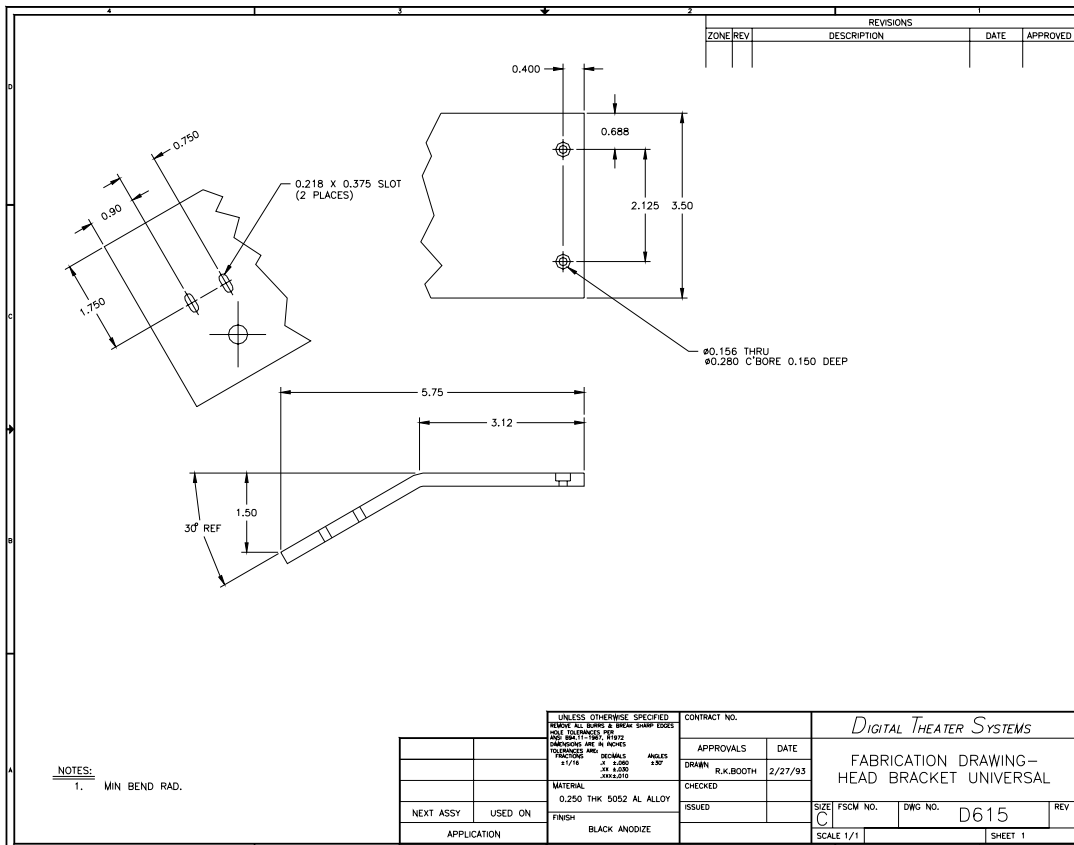
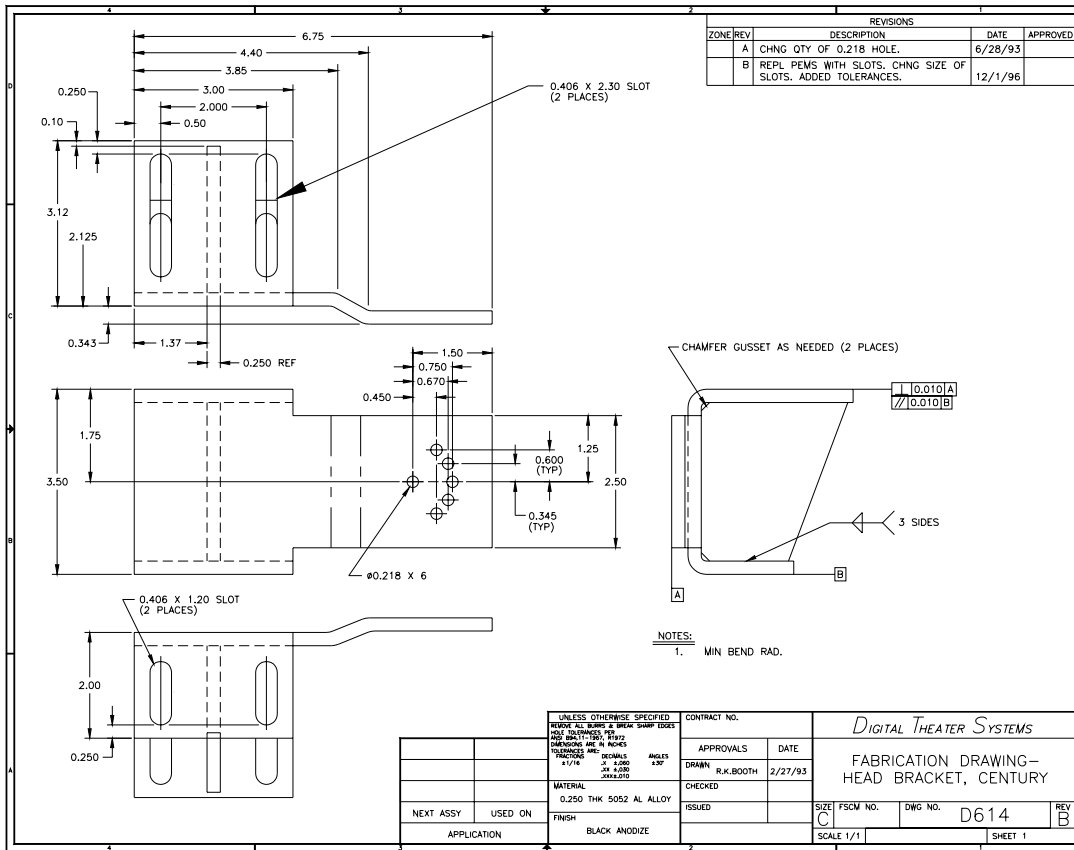

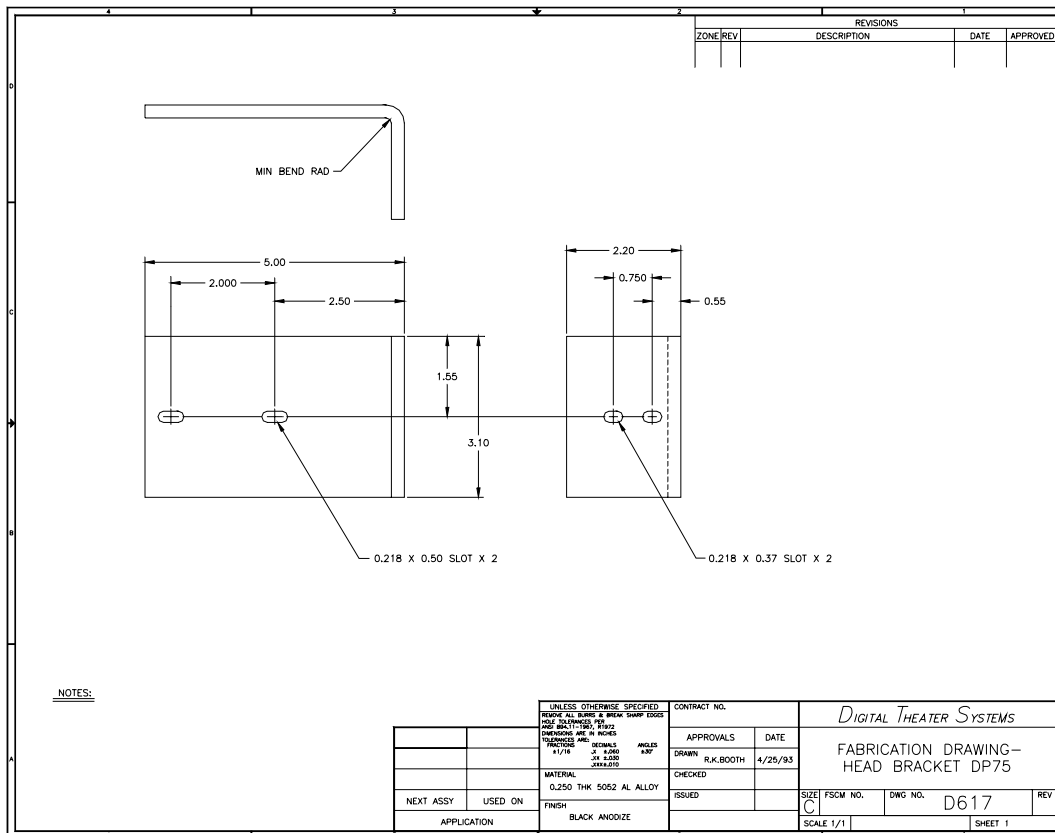
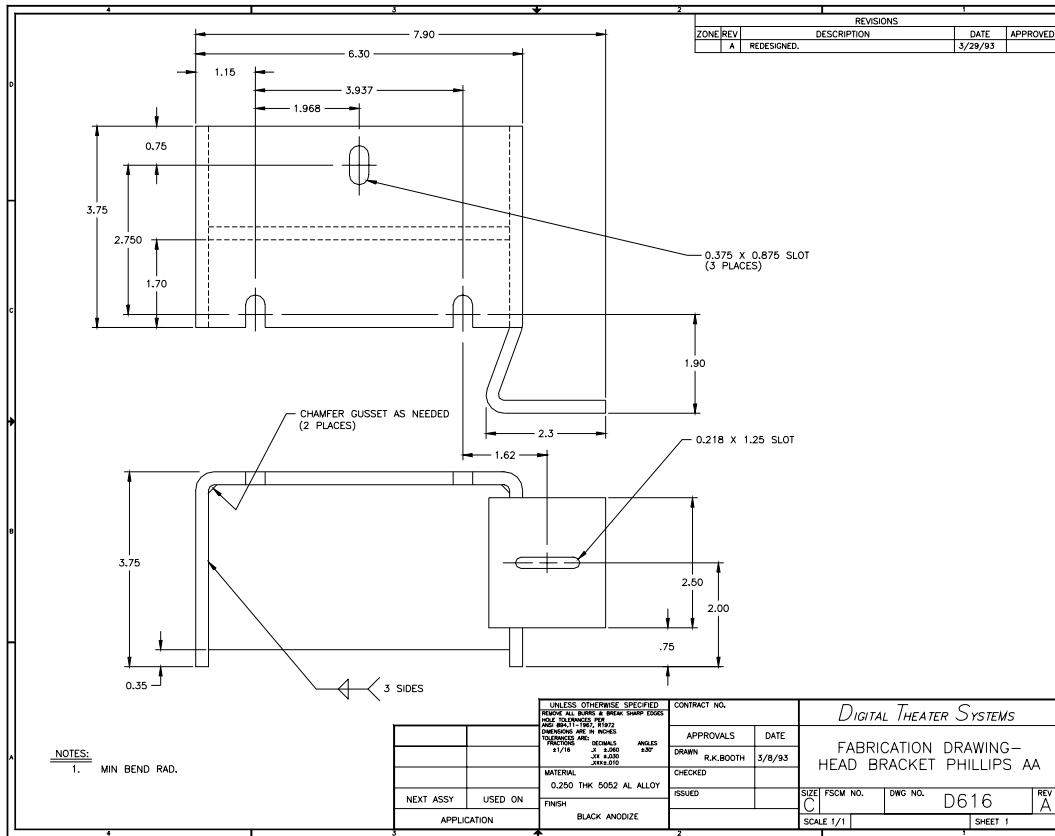

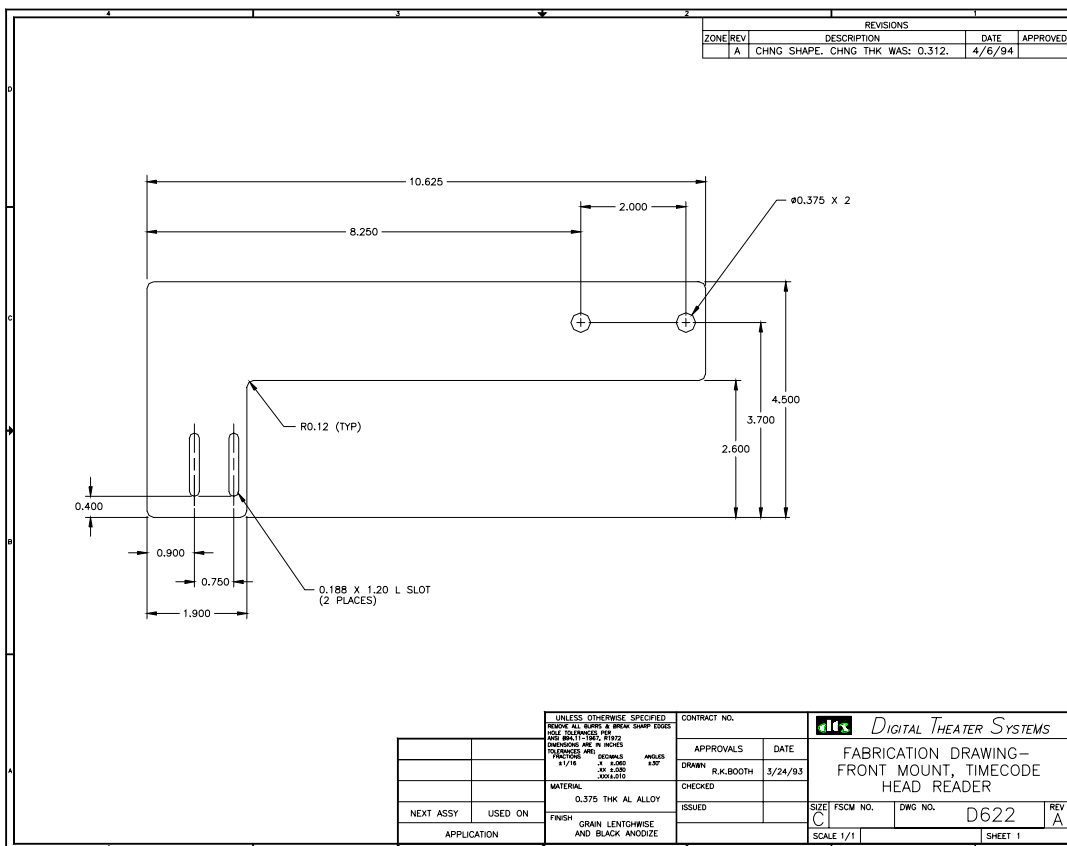
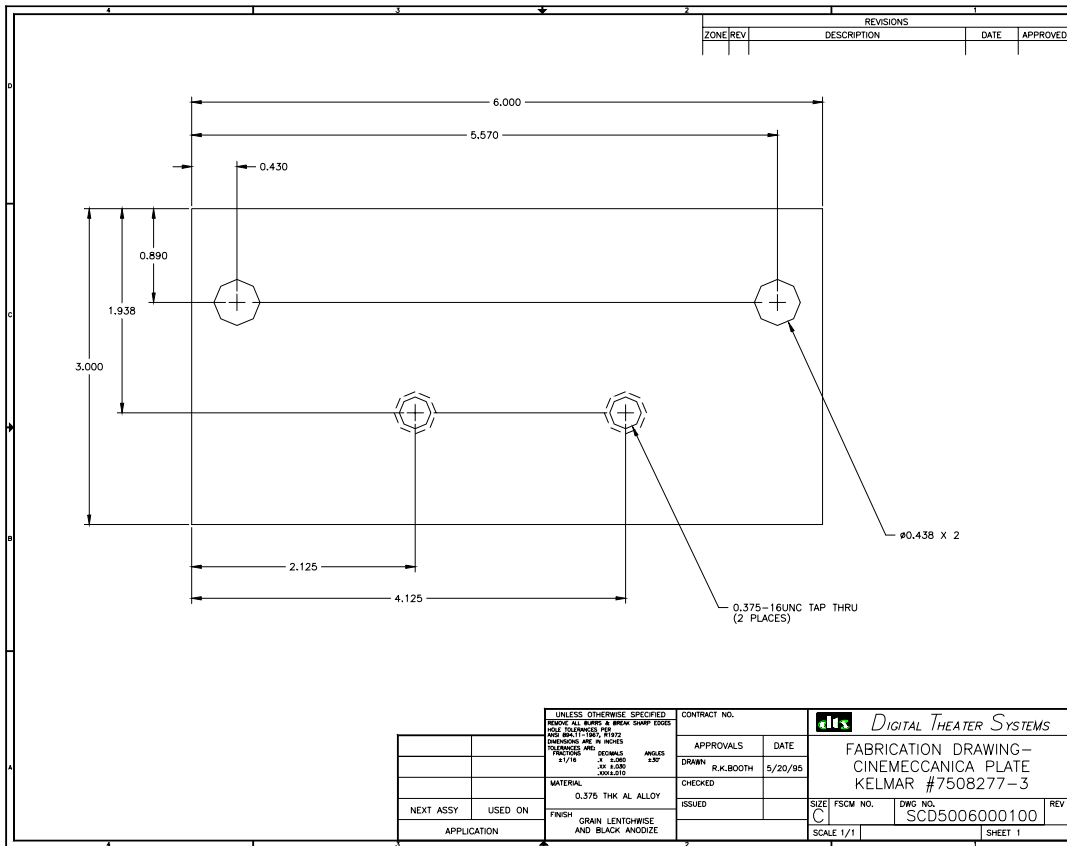

**Mounting adapters used when switching between  
35mm & 70mm readers (next 3 pages)**

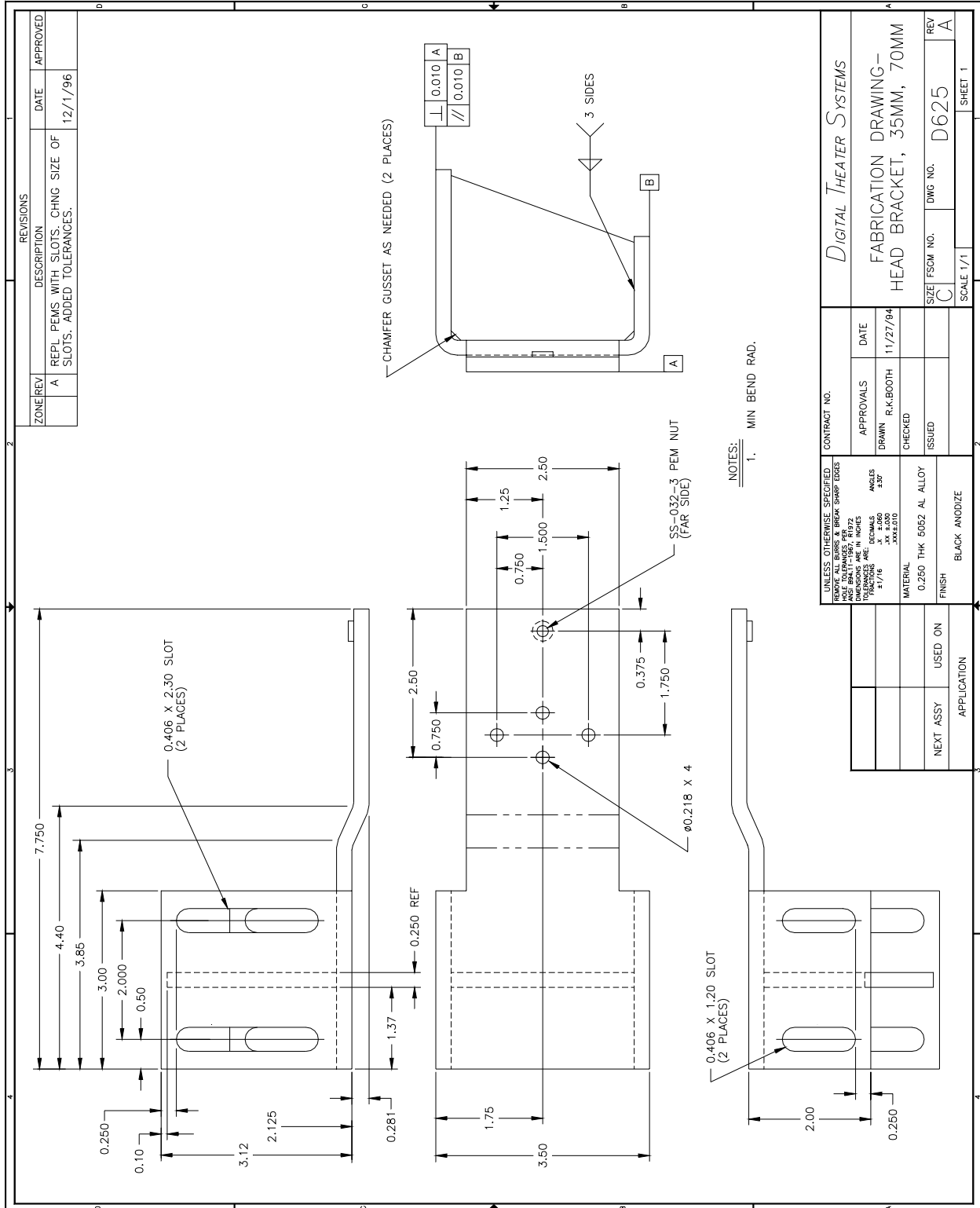



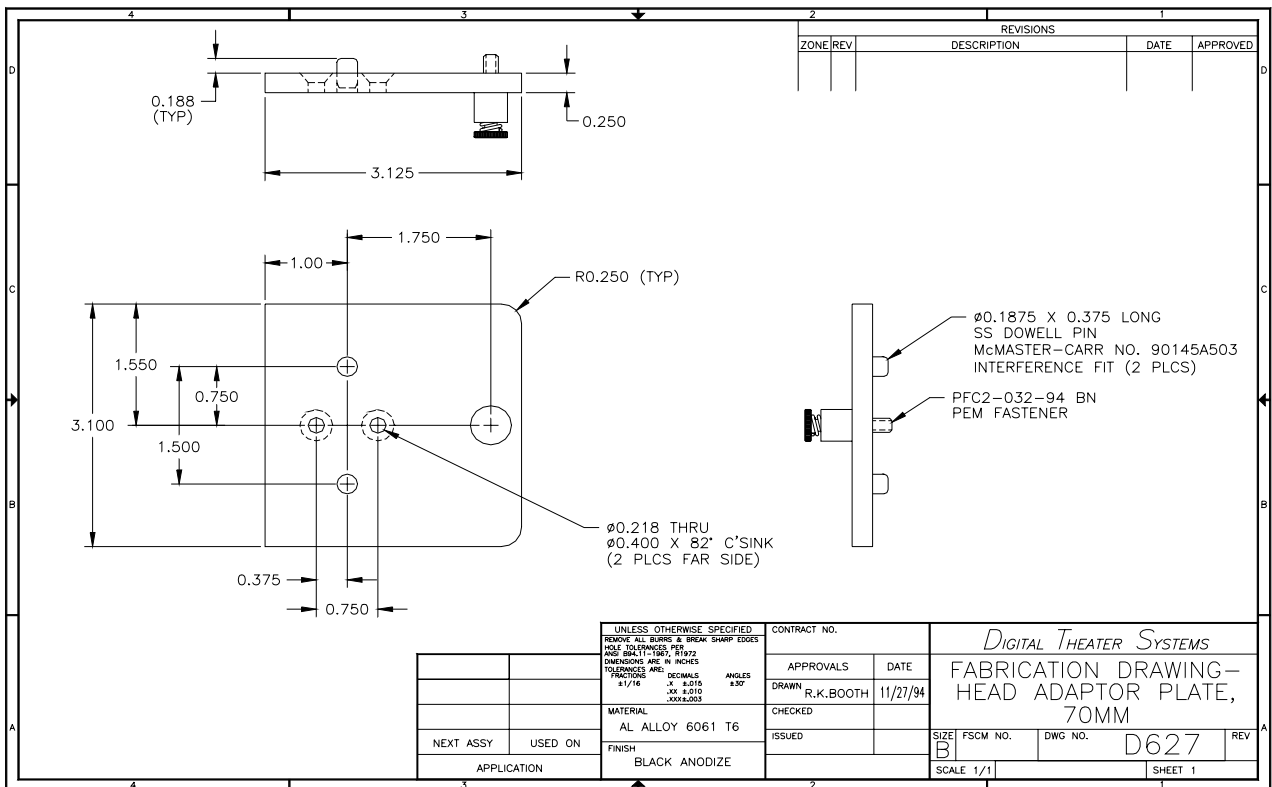
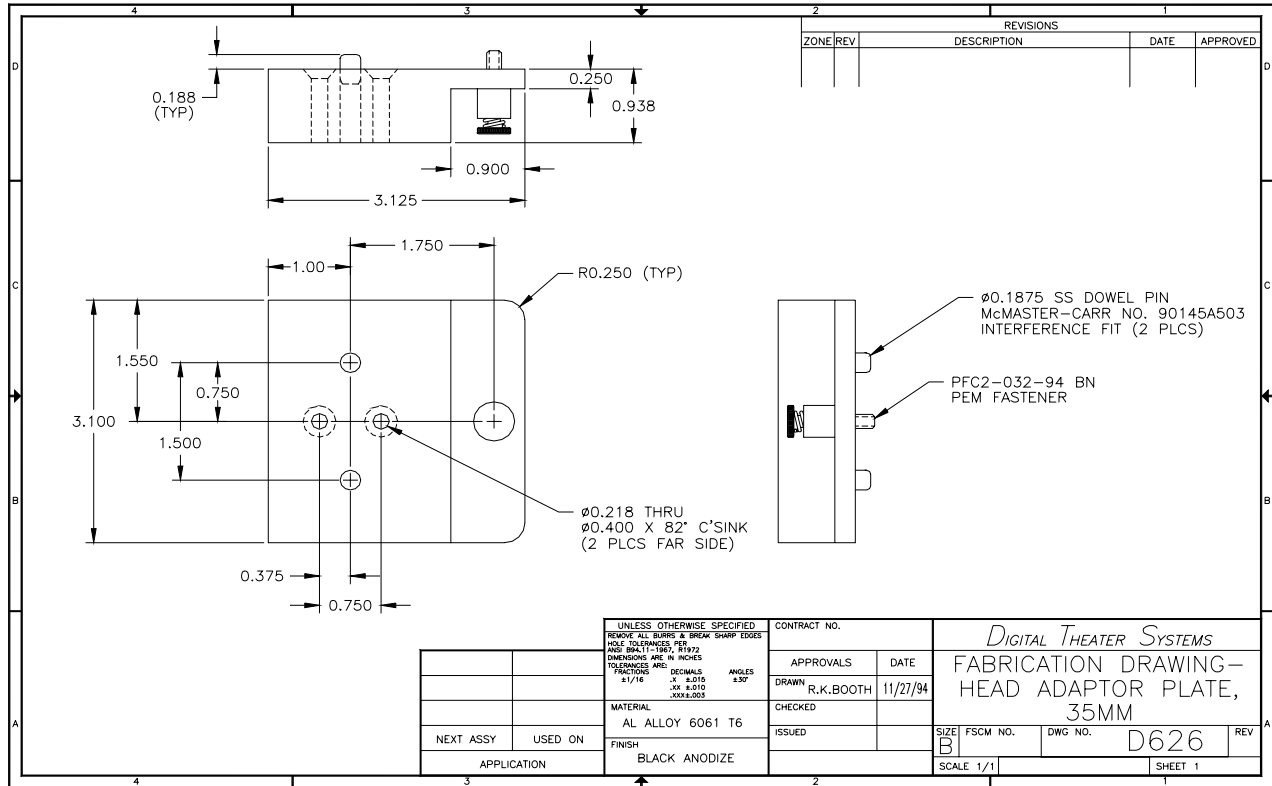

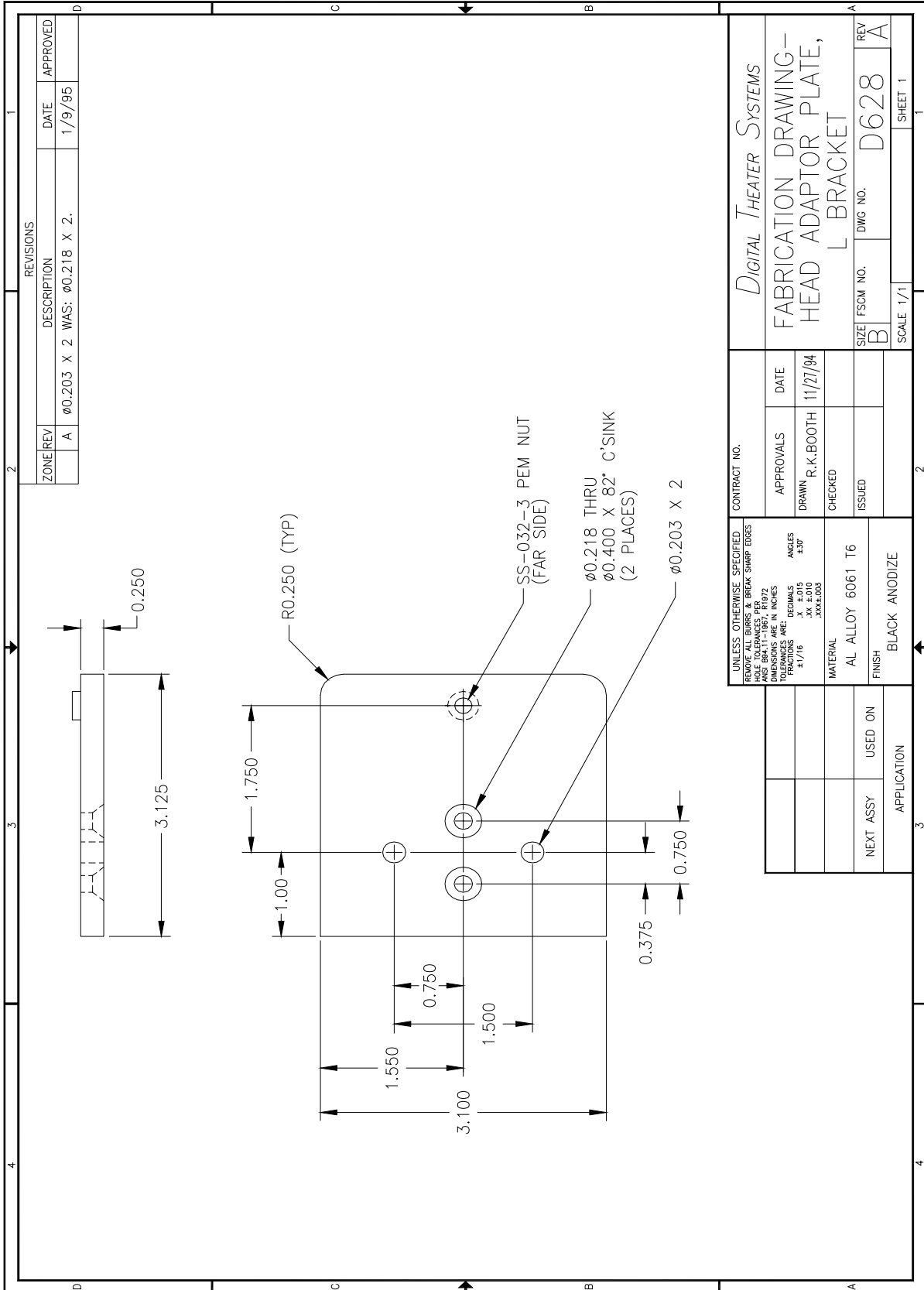

**Installing DTS Timecode Reader with spacer plates on a projector with a “mag” (magnetic) head.**

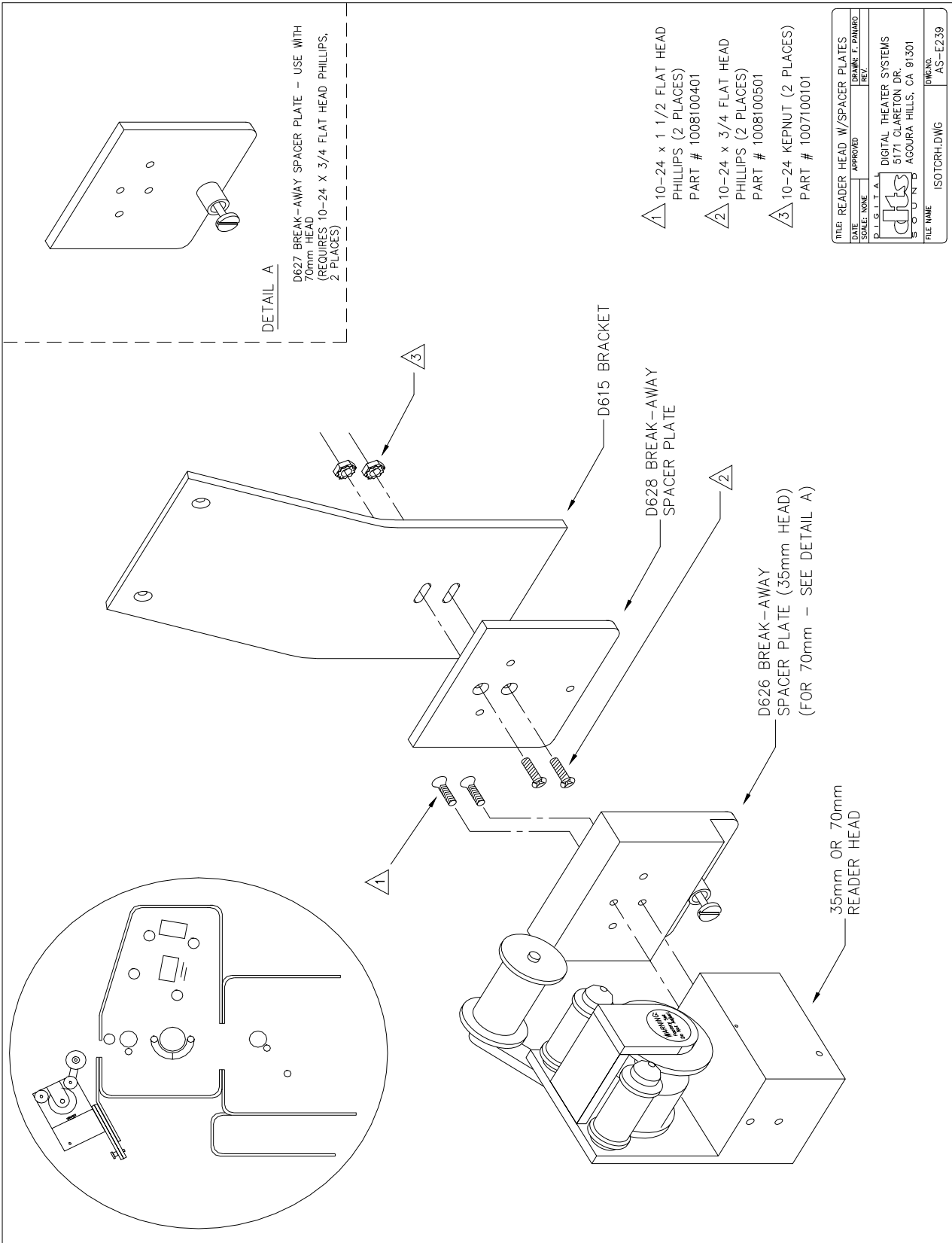

## B.3. Timecode Reader Head Aux Roller Installation

### Installation Procedure, Timecode Reader Head Auxiliary Roller

The Auxiliary Roller is designed to mount on either of the two Secondary rollers of the Timecode Reader Head, as detailed below:

1. Remove the screw ① from the end cap ② of the desired secondary roller ③, and remove the end cap ②.
2. Loosen the set screw ④ which holds the roller shaft ⑤ of the secondary roller ③.
3. Gently push the roller shaft ⑤ out of the secondary roller ③. Note: Excessive force may damage the bearings ⑥. Be careful not to lose the washer ⑦, or the bearings ⑥ that mount on the roller shaft ⑤.
4. Install the longer roller shaft ⑧ provided. Note: The flat section on the roller shaft ⑧ should face the set screw ④ in the Reader Head. About 1/4" of the longer roller shaft ⑧ will protrude from the bottom of the Reader Head.
5. Tighten the set screw ④, and replace the secondary roller ③ and end cap ②.
6. Make sure that the secondary roller ③ spins freely. If not, loosen the set screw ④ and adjust the roller shaft ⑤ up slightly. This should free the secondary roller ③. If, after adjustment the secondary roller ③ still does not spin, double check that all parts have been properly replaced onto the roller shaft ⑤.
7. Place the Auxiliary Roller ⑨ on the protruding section of the roller shaft ⑧, in the desired position ⑩, and tighten the cap screw ⑪. For most installations, keeping the auxiliary roller close to the large center roller achieves the best results. Add a second auxiliary roller ⑫ if necessary, to stabilize film.

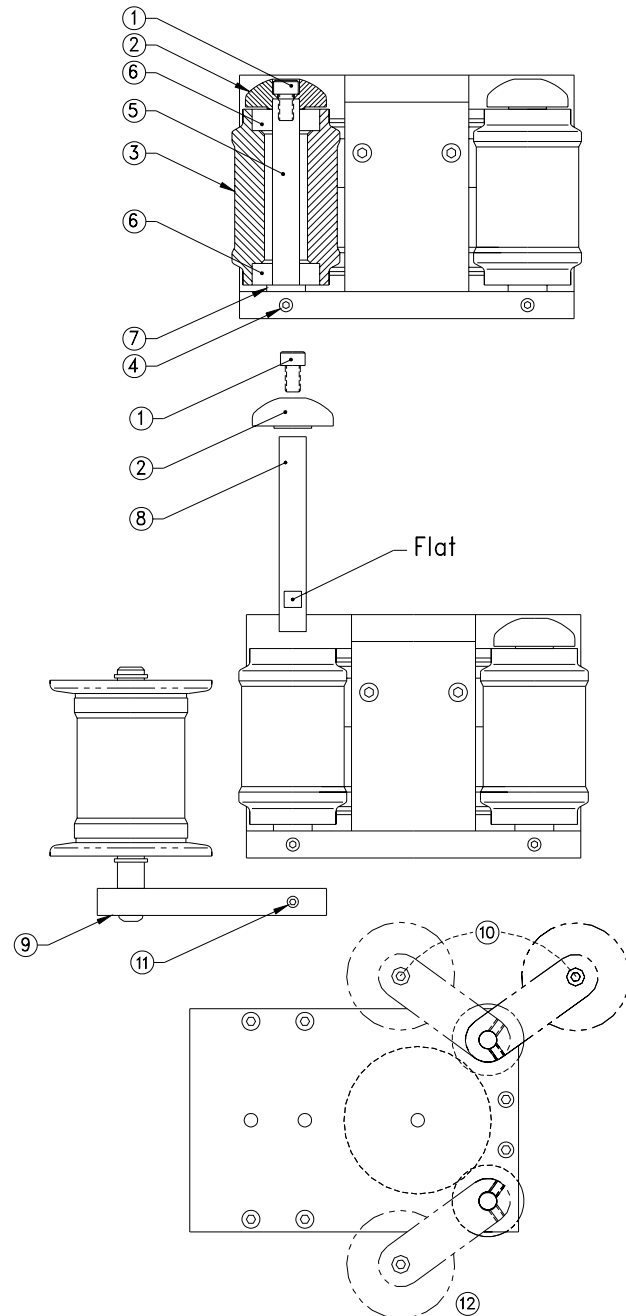

### Aux Roller Installation Procedure

### B.4. Timecode Reader Head Drawings

☑ These drawings are to be used to help installers determine Timecode offset (delay) only.

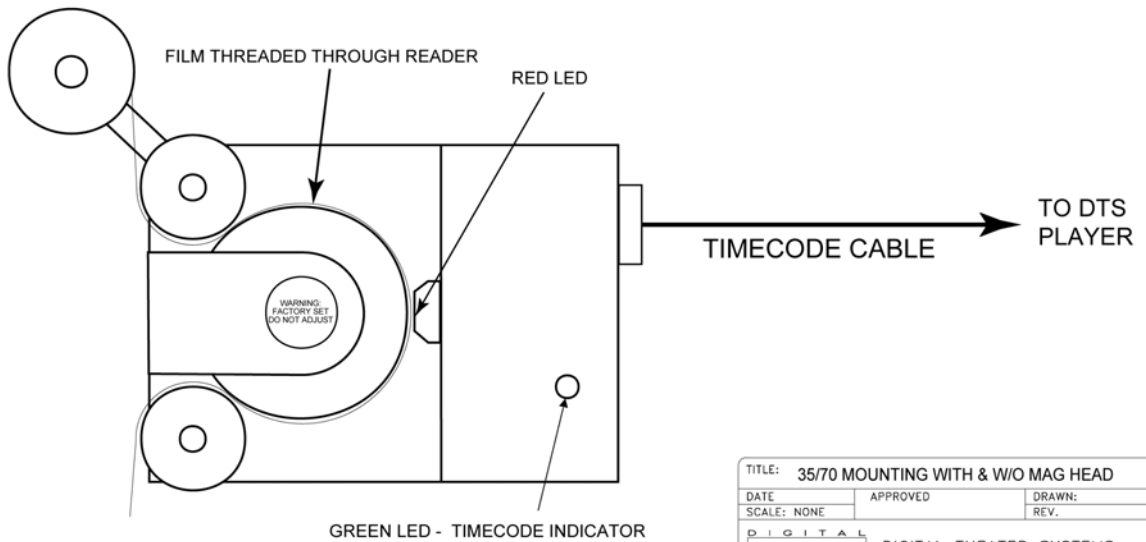
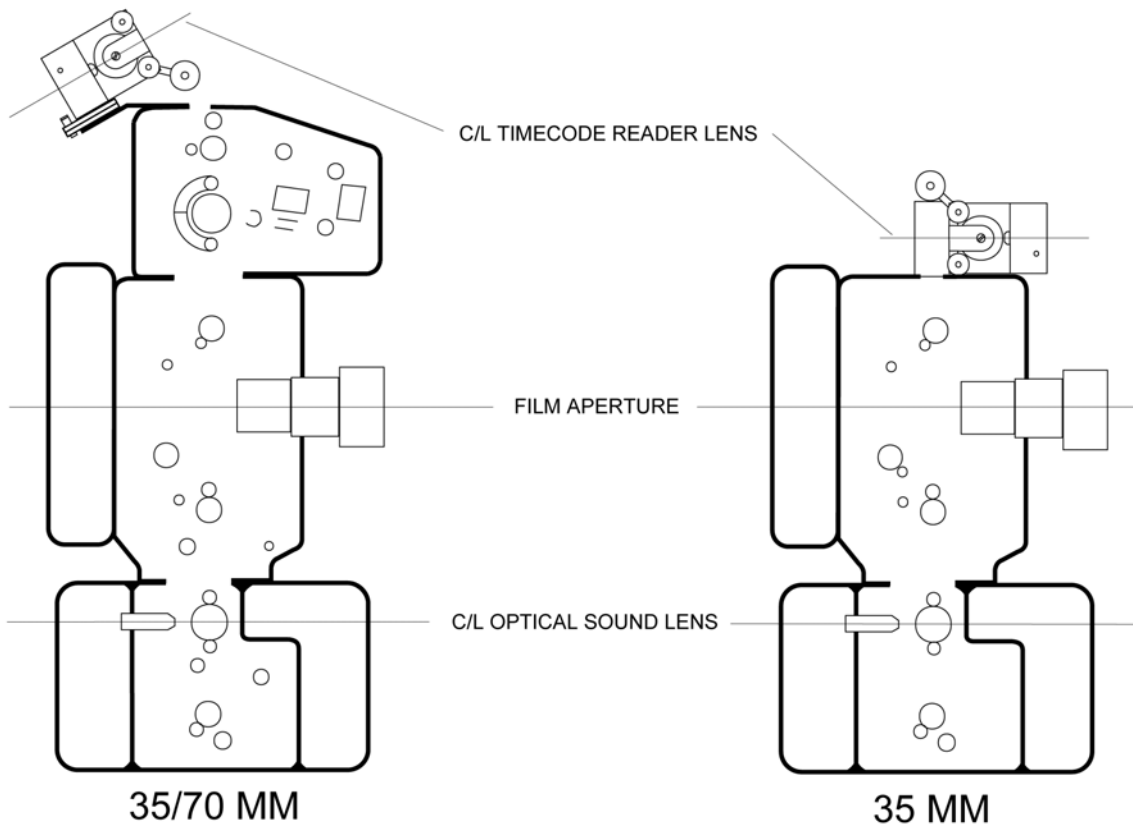

TITLE: 35/70 MOUNTING WITH & W/O MAG HEAD		
DATE	APPROVED	DRAWN:
SCALE: NONE		REV.
DIGITAL THEATER SYSTEMS 5171 CLARETON DR. AGOURA HILLS, CA 91301		
FILE NAME	DWG. NO.	
TIE245A (3570MAG).AI	TI-E245	

## B.5. DTS 35mm and 70mm Readers, Switchable, Using the Same Bracket

If both 35mm and 70mm reader heads are to be used on the same bracket, add spacer breakaway plates to the readers. They are added to allow quick changes between the two. Keep the plates attached to the readers and maintain them as a set once the projector alignments are finished. See below.

1. Start by mounting the 70mm reader (with its breakaway plate attached) to the bracket.
2. Use 70mm film to align the reader. Once aligned, tighten bracket screws.
3. Loosen the thumbscrew on the breakaway plate so that the 70mm reader detaches from the bracket.
4. Next, attach the 35mm reader (with its breakaway plate attached) to the bracket.
5. Use 35mm film to verify the alignment path is correct -- no corrections should be necessary.

The goal is to have one alignment for both readers so that no projector adjustments are needed when the readers are exchanged.

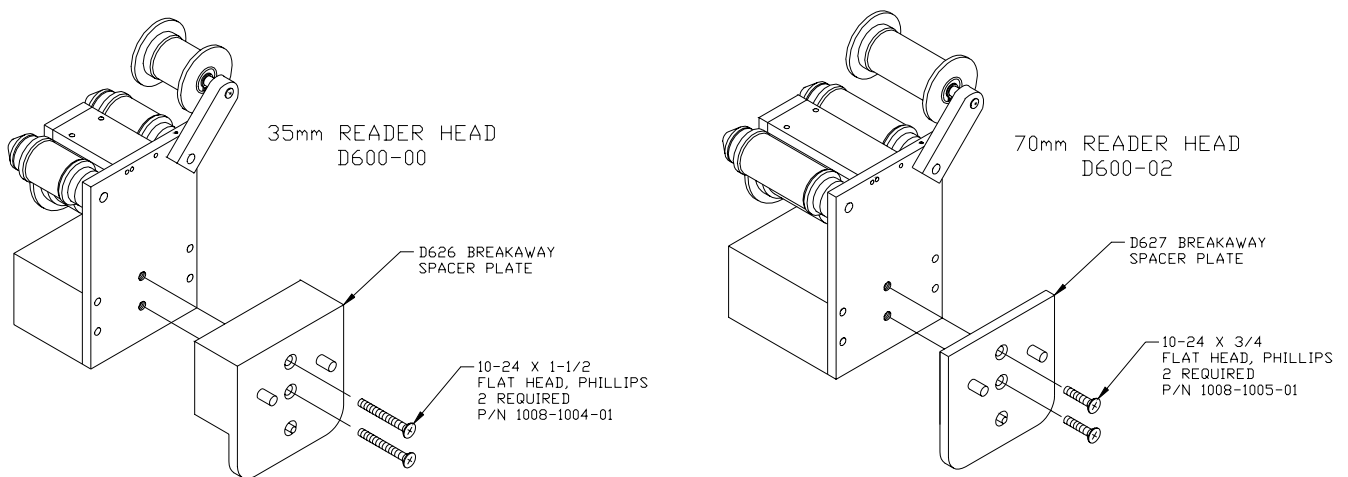

Attach Breakaway Spacer Plates to Reader Heads

# DTS - 70mm Timecode Reader and Mounting Brackets

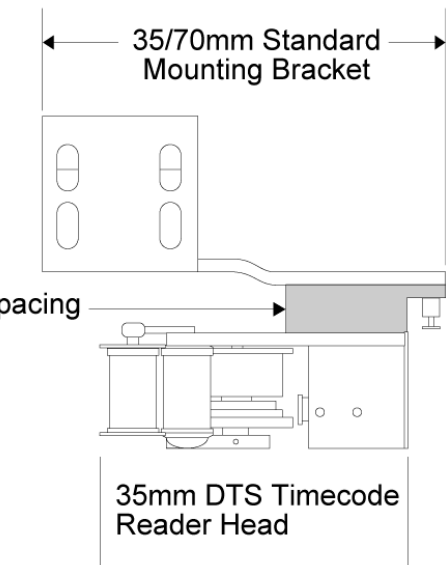
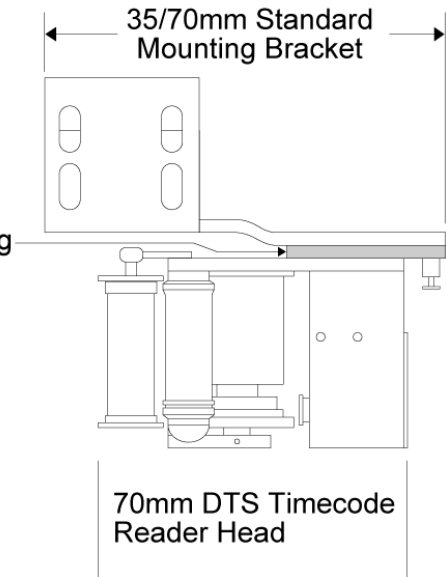
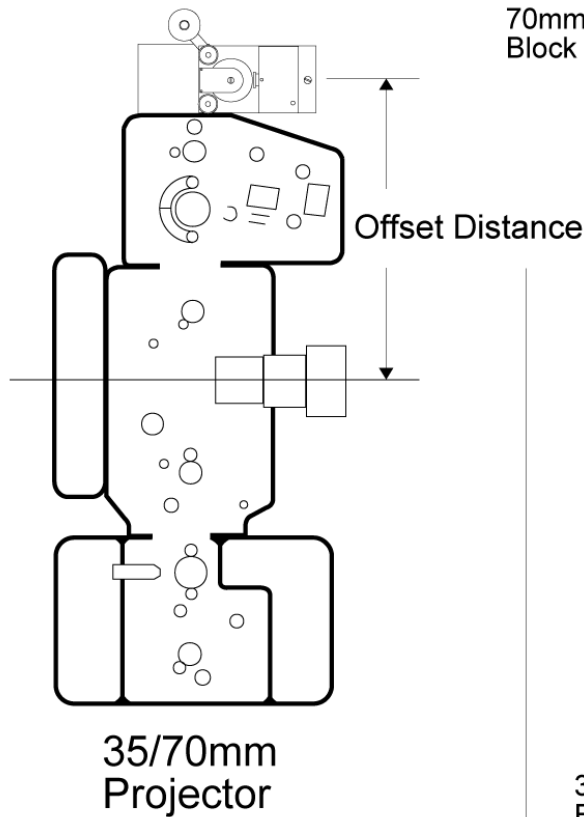

In order to properly set the offset for 70mm film on the DTS unit, count the number of frames between the picture aperture and the timecode reader head. Multiply by 1.25 and subtract one.

For example,

Distance between (70mm) Picture Aperture & Timecode Reader Head	24 Frame/Sec Offset Setting
(24 frames X 1.25) - 1	=29
(12 frames X 1.25) - 1	=14

TITLE: 70MM TCRH MOUNTING & BRACKETS		
DATE	APPROVED	DRAWN: J. DELLARIA
SCALE: NONE		REV. A
DIGITAL THEATER SYSTEMS 5171 CLARETON DR. AGOURA HILLS, CA 91301		
FILE NAME	TIE241A (70MM-MNT).AI	DWG. NO. TI-E241A

PH: 818-706-3525 Fax: 818-706-1868  
 Web: www.dtsonline.com

Mounting adapters when switching between 35mm and 70mm Readers







## Appendix C. XD10 Menu Structure

### MAIN MENU

#### PLAYBACK MENU

- Soundtrack
  - Soundtrack Language
    - ( )Automation
    - ( )Last Installed
    - ( )English (etc.)
    - Exit Menus
- Video
  - Play Menu
    - VIDEO PLAY MENU
      - Play
        - Select Playlist
        - *SHOWS ACTUAL PLAYLIST, for example:*
          - ( )Long\_List
          - ( )1\_3\_List
          - etc.
      - Stop
      - Stop at Seg End
      - Exit Menus
  - Status Menu
    - *SHOWS VIDEO PLAY SETTINGS, for example:*
    - PL: Long\_List
    - Seg: Piano
    - Seg: 01 of 06
    - Repeat: Off
    - Playlist Zone 00
    - Player Zone 00
    - Audio Type DTS
  - Control Menu
    - CONTROL MENU
      - Set Repeat
        - REPEAT MENU
          - ( )Playlist
          - ( )Segment
          - ( )Off
        - Exit Menus
      - Next Segment
      - Prev Segment
      - Play
      - Stop
      - Exit Menus



- Video Logging
  - VIDEO LOG MAIN MENU
    - Log Report Menu
      - Select Report Type
        - Report Type
          - ( )Content
          - ( )Playlist
          - ( )Both
          - Exit Menus
      - Select Report Date
        - Report Period
          - ( )Today
          - ( )Yesterday
          - ( )Past 7 Days
          - ( )Past 24 Days
          - ( ) Past 30 Days
          - ( )Current Month
          - ( )Previous Month
          - Exit Menus
      - Create & Export
        - PC ready to receive Log Report via IrDA?
        - [ Yes (Send) ]
        - Sending Log Report to PC...Please Wait
        - [ No (Cancel) ]
      - Log Control Menu
        - VIDEO LOG CTRL MENU
          - Disable Logging
            - Enable/Disable Log
              - ( )Disable Logging
              - ( )Enable Logging
              - Exit Menus
          - Delete Video Logs
            - Delete All Video Logs?
            - ( )No (Cancel)
            - ( )Yes (Delete)
          - Exit Menus
      - Exit Menus
  
- CSP Language
  - ( )Automation
  - ( )None
  - (List of Installed Languages)
  - Exit Menu



- Contents
  - CONTENTS MENU
    - Features
      - Contents: Features
        - *Films and Trailer names are shown*
    - Trailers
      - Contents: Trailers
        - *thxbrdwy, etc.*
    - Delete Contents
      - DELETE CONTENTS MENU
        - Delete All
          - Delete All Contents?
            - No (Cancel)  
Delete contents aborted! <Press Enter>
            - Yes (Delete)
        - Features
          - Delete: Features
            - *Film Title*
            - 
            - 
            - *Film Title*
        - Trailers
          - Delete: Trailers
            - *Trailer ID*
            - 
            - 
            - *Trailer ID*
        - Exit Menus
    - Exit Menus
- CSP Lamp Status
  - Current Lamp hours: (     )
  - Exit Menus



- Setup
  - SYSTEM SETUP MENU
    - TC Reader Offset
      - Set Timecode Reader Offset:  
[ n.nn] Frames
    - Audio Setup
      - AUDIO SETUP MENU
        - Level Adjustment
          - Select Audio
            - Play 300mV Tone
            - Play Pink Noise
              - Adjust level for Ch1 (left)  
[ + 00.0 dB ]  
tone on all channels  
Ch1 -- Right  
Ch1 -- Center  
Ch1 -- Sub Bass  
Ch1 -- Left Surr  
Ch1 -- Right Surr  
Ch1 -- Right Ex  
Ch1 -- Left Ex  
Ch1 -- Right Bk  
Ch1 -- Left Bk
  - Language Versions
    - Language Versions
      - ( )Enabled
      - ( )Disabled
      - Exit Menus
  - Audio Tests
    - Audio Tests Menu
      - ( )Test Name
      - ( )Test Name
      - Exit Menus
  - Exit Menus



- Video Setup
  - INSTALLATION MENU
    - Set Image
      - SET IMAGE MENU
        - Resolution
          - RESOLUTION MENU
            - ( ) 1024 x 768
            - ( ) 1280 x 1024
            - Exit Menus
        - Brightness
          - Set Brightness
          - Brightness: n/100
        - Contrast
          - Set Contrast
          - Contrast: n/100
        - Cal Location
          - Use U,D,L,R
          - to Adjust Image
          - Enter to Save & Exit
        - Cal Width
          - Use Up / Down
          - to Adjust Width
          - Enter to Save & Exit Menu
      - Set Player Zone
        - Set Player Zone
        - Player Zone = (00-99)
      - Set AutoStop
        - Auto Stop Menu
          - ( ) Stop Immediately
          - ( ) Stop at Seg end
          - Exit Menus
      - Set Application
        - Application Menu
          - ( ) Common Height
          - ( ) Common Width
          - Exit Menus
      - Set Test/Normal
        - MODE MENU
          - ( ) Normal
          - ( ) Test
          - Exit Menus
      - Factory Settings
        - ( ) Keep Current
        - ( ) Restore Video Default
      - Exit Menu



- CSP Setup  
CSP SETUP
  - Image Size
    - Image Size Menu
      - ( )100%
      - ( )90%
      - ( )80%
      - ( )70%
      - ( )60%
      - ( )50%
      - Exit
  - Vertical Offset
    - Set Projector
      - Vertical Offset:  
[ 0 ] pixels
  - Test Patterns
    - Test Pattern Menu
      - ( ) Black
      - ( ) Flat Mask
      - ( ) Scope Mask
      - ( ) View Area
      - ( ) White
      - ( ) Full Screen
      - ( ) Gray Pattern (1)
      - ( ) Gray Pattern (2)
      - ( ) Gray Pattern (3)
      - ( ) Gray Pattern (4)
      - Exit Menus



- Options
  - Douser Type
    - ( ) Electronic
    - ( ) Mechanical
  - Background Color
    - ( ) Normal
    - ( ) Black
  - Light Intensity
    - ( ) Low
    - ( ) High
  - Exit Menus
- Exit Menus
- Automation Setup
  - AUTOMATION/CONTROL
    - Format
      - FORMAT AUTOMATION
        - Pin Definitions
          - FORMAT PIN DEFINITIONS
            - Predefined Formats
              - Automation Preset
                - ( ) DTS-6D Emulation
                - ( ) DTS-6AD/ECP
                - ( ) CP-65
                - ( ) CP-500
                - ( ) CP-650
                - ( ) Ultrastereo
                - ( ) Exit Menus
              - Custom
                - Format Pins
                  - Pin 1:
                    - Change Pin X
                    - (...)Unused
                    - (...)Mono
                    - (...)A
                    - (...)SR (1)
                    - (...)etc.
                  - Pin 2:
                  - Pin 3:
                  - Pin 4:
                  - Pin 5:
                  - Pin 6:
                  - Pin 7:
                  - Pin 8:
                  - Exit Menus
- Exit Menus

- Fallback Format
  - Fallback Formats
    - Soundtrack
      - Soundtrack Fallback
        - ( ) Automatic
        - ( ) Mono
        - ( ) A
        - ( ) etc.
        - ( ) Exit Menus
    - Video
      - Video Fallback
        - ( ) Mono
        - ( ) A
        - ( ) SR (1)
        - ( ) etc.
        - ( ) Exit Menus
    - Exit Menu
  - Operating Mode
    - Automation Mode
      - ( ) DTS-6D Emulation
      - ( ) Auto-Switch
      - ( ) Preselect Mode
      - ( ) Exit Menu
    - Exit Menu
  - I/O Control
    - I/O CONTROL
      - Pin Definitions
        - I/O PIN DEFINITIONS
          - Inputs
            - INPUT CONTROL PINS
              - In 1: Unassigned
              - In 2: Unassigned
              - In 3: Unassigned
              - Exit Menu
          - Outputs
            - OUTPUT CONTROL PINS
              - Out 1: Unassigned
              - Out 2: Unassigned
              - Out 3: Unassigned
              - Exit Menu
          - Exit Menu
        - Language Setups
          - LANGUAGE SETUP MENU
            - Default
              - LANGUAGE DEFAULT
                - Soundtrack
                  - Soundtrack Default
                    - ( ) English
                    - ( ) Fr. Canadian
                    - ( ) Braz. Portuguese
                    - ( ) Etc.
                    - ( ) Exit Menus
                  - Subtitle
                    - Subtitle Default
                      - ( ) None (Off)
                      - ( ) English
                      - ( ) Fr. Canadian
                      - ( ) Braz. Portuguese
                      - ( ) Etc.
                      - ( ) Exit Menu
                - Setup Input 1
                  - Language Setup 1
                    - Soundtrack





- Language #1
    - ( )English
    - ( )Fr. Canadian
    - (...)Exit Menu
  - Subtitle
    - Subtitle #1
      - ( )CSP Off
      - ( )Undefined
      - ( )Arabic
      - (...)Exit Menu
  - Setup Input 2
    - Language Setup 2 (Same as above)
  - Setup Input 3
    - Language Setup 3 (Same as above)
  - Exit Menu
- Exit Menu
- Automation Test
  - Automation Test
    - Fmt: ----- In: \*---
    - [ P1: External ]
    - [Enter] to Pulse
- Exit Menu
- System Options
  - SYSTEM OPTIONS MENU
    - COM2 Configuration
      - COM2 Configuration
        - ( )EMA Port
        - ( )IR Port
    - Set Password
      - Password:
        - [ 0 0 0 ]
        - \*
    - Network
      - NETWORK MENU
        - Enable/Disable
          - Network Enable
            - ( )Disabled
            - ( )Enabled
            - ( )Exit Menu
        - Address
          - Network IP address
            - [XXX>XX>X>XX]
      - Exit Menu



- System Clock
  - SYSTEM CLOCK MENU
    - Set Time Zone
      - Select Time Zone Location:  
[Americas]
      - Select Country:  
[United States]
      - Select Time Zone and hit 'Enter'  
[America/Los Angeles]
    - Set System Date
      - Set Date:  
[MM"DD"YYYY]
      - [00:00:2000]
      - \*
    - Set System Time
      - Set Time:  
[hh:mm:ss]
      - [00:00:00]
      - \*
    - View Time Zone
      - Current Time Zone:  
[ *Entry from List* ]
    - Exit Menus
  - Exit Menus
- Display Language
  - ( )English
  - ( )French
  - ( )Etc.
  - ( )Exit Menus
- Exit Menus
- Info Menu
  - Version
    - DTS-XD10 100,rde
    - Jan 20 2003 23:50:44
    - Copyright (c) 2001
    - by Digital Theater Systems, Inc.
  - MAC Address
    - DTS-XD10 MAC addr:
    - 00:01:80:ED:6C
- Exit Menus

## Appendix D. Language Management

### D.1. Soundtrack Dubbed Languages

| Area          | Language          | Code | Code ext (Note 1) |
|---------------|-------------------|------|-------------------|
| NORTH AMERICA | English           | ENG  |                   |
|               | Fr. Canadian      | FRN  | C                 |
| SOUTH AMERICA | Braz. Portuguese  | POR  | B                 |
|               | Latin Spanish     | SPN  | L                 |
| EUROPE        | Basque            | BAS  |                   |
|               | Bulgarian         | BUL  |                   |
|               | Castilian Spanish | SPN  | C                 |
|               | Catalan           | CAT  |                   |
|               | Croatian          | CRO  |                   |
|               | Czech             | CZC  |                   |
|               | Danish            | DAN  |                   |
|               | Dutch             | DUT  |                   |
|               | Finnish           | FIN  |                   |
|               | Flemish           | FLM  |                   |
|               | French            | FRN  |                   |
|               | German            | GER  |                   |
|               | Greek             | GRK  |                   |
|               | Hebrew            | HEB  |                   |
|               | Hungarian         | HUN  |                   |
|               | Icelandic         | ICE  |                   |
|               | Italian           | ITL  |                   |
|               | Norwegian         | NOR  |                   |
|               | Polish            | POL  |                   |
|               | Portuguese        | POR  |                   |
|               | Russian           | RUS  |                   |
|               | Slovak            | SLV  |                   |
|               | Slovenian         | SLO  |                   |
|               | Swedish           | SWD  |                   |
|               | Swiss German      | GER  | S                 |
|               | Turkish           | TRK  |                   |
|               | Yugoslavian       | YUG  |                   |
| ASIA:         | Cantonese         | CAN  |                   |
|               | Indonesian        | IND  |                   |
|               | Japanese          | JAP  |                   |
|               | Korean            | KOR  |                   |
|               | Malay             | MAL  |                   |



| Area                | Language   | Code | Code ext (Note 1) |
|---------------------|------------|------|-------------------|
|                     | Mandarin   | MAN  |                   |
|                     | Tamil      | TAM  |                   |
|                     | Telugu     | TEL  |                   |
|                     | Thai       | THA  |                   |
|                     | Urdu       | URD  |                   |
|                     | Vietnamese | VTN  |                   |
| AFRICA/ MIDDLE EAST | Arabic     | ARB  |                   |
|                     | Zulu       | ZUL  |                   |

## D.2. File Header (Header.exe)

The Language Field in the file header should be set with the language code and extension with the following format:

Language :     \*CCCX

\*     First character in the language field must contain this character.

CCC   3 Letter language code

X     1 Letter extension code if applicable

Examples:

Language field for English version:

Language :     \*ENG

Language field for Latin Spanish:

Language :     \*SPNL

**Note:** The code extension selects between two files with the same code. If two files with the same code are loaded, then the extension is used to determine which file to use. Otherwise the file will play even if the extension does not match.

### D.2.1. XD10 Operation

The XD10 can store multiple languages of any given movie. The operator selects which language version they wish to play. The language code must match the selected language. If more than one file is loaded with the same language code, then the code extension is used to determine which of those will play.

Discs that are loaded without new language code will ask the user to enter the language for the disc they are loading.

### D.2.2. Trailers

Trailers will work the same as features. All trailer files from the compiled trailer file will be assigned the same language.

### D.3. Subtitle Languages

Subtitle languages do not differentiate the following:

- German or Swiss German
- Castilian Spanish or Latin Spanish
- Portuguese or Brazilian Portuguese
- French or French Canadian

| Area               | Language         | Code                | Code ext |  |
|--------------------|------------------|---------------------|----------|--|
| EUROPE (& AMERICA) | Basque           | BAS                 |          |  |
|                    | Bulgarian        | BUL                 |          |  |
|                    | Catalan          | CAT                 |          |  |
|                    | Croatian         | CRO                 |          |  |
|                    | Czech            | CZC                 |          |  |
|                    | Danish           | DAN                 |          |  |
|                    | Dutch            | DUT                 |          |  |
|                    | English          | ENG                 |          |  |
|                    | English Captions | ENG                 | C        |  |
|                    | Finnish          | FIN                 |          |  |
|                    | Flemish          | FLM                 |          |  |
|                    | French           | FRN                 |          |  |
|                    | German           | GER                 |          |  |
|                    | Greek            | GRK                 |          |  |
|                    | Hebrew           | HEB                 |          |  |
|                    | Hungarian        | HUN                 |          |  |
|                    | Icelandic        | ICE                 |          |  |
|                    | Italian          | ITL                 |          |  |
|                    | Norwegian        | NOR                 |          |  |
|                    | Polish           | POL                 |          |  |
|                    | Portuguese       | POR                 |          |  |
|                    | Russian          | RUS                 |          |  |
|                    | Slovak           | SLV                 |          |  |
|                    | Slovenian        | SLO                 |          |  |
|                    | Spanish          | SPN                 |          |  |
|                    | Swedish          | SWD                 |          |  |
|                    | Turkish          | TRK                 |          |  |
|                    | Yugoslavian      | YUG                 |          |  |
|                    | ASIA             | Cantonese           | CAN      |  |
|                    |                  | Indonesian          | IND      |  |
|                    |                  | Japanese            | JAP      |  |
|                    |                  | Korean (Horizontal) | KRH      |  |
| Korean (Vertical)  |                  | KRV                 |          |  |
|                    | Malay            | MAL                 |          |  |



| Area                | Language   | Code | Code ext |
|---------------------|------------|------|----------|
|                     | Mandarin   | MAN  |          |
|                     | Tamil      | TAM  |          |
|                     | Telugu     | TEL  |          |
|                     | Thai       | THA  |          |
|                     | Urdu       | URD  |          |
|                     | Vietnamese | VTN  |          |
| AFRICA/ MIDDLE EAST | Arabic     | ARB  |          |
|                     | Zulu       | ZUL  |          |

- Note:** The code extension selects between two files with the same code. If two files with the same code are loaded, then the extension is used to determine which file to use. Otherwise the file will play even if the extension does not match.

# Appendix E. DTS Track Specifications

35mm

## DTS 35mm TRACK SPECIFICATION

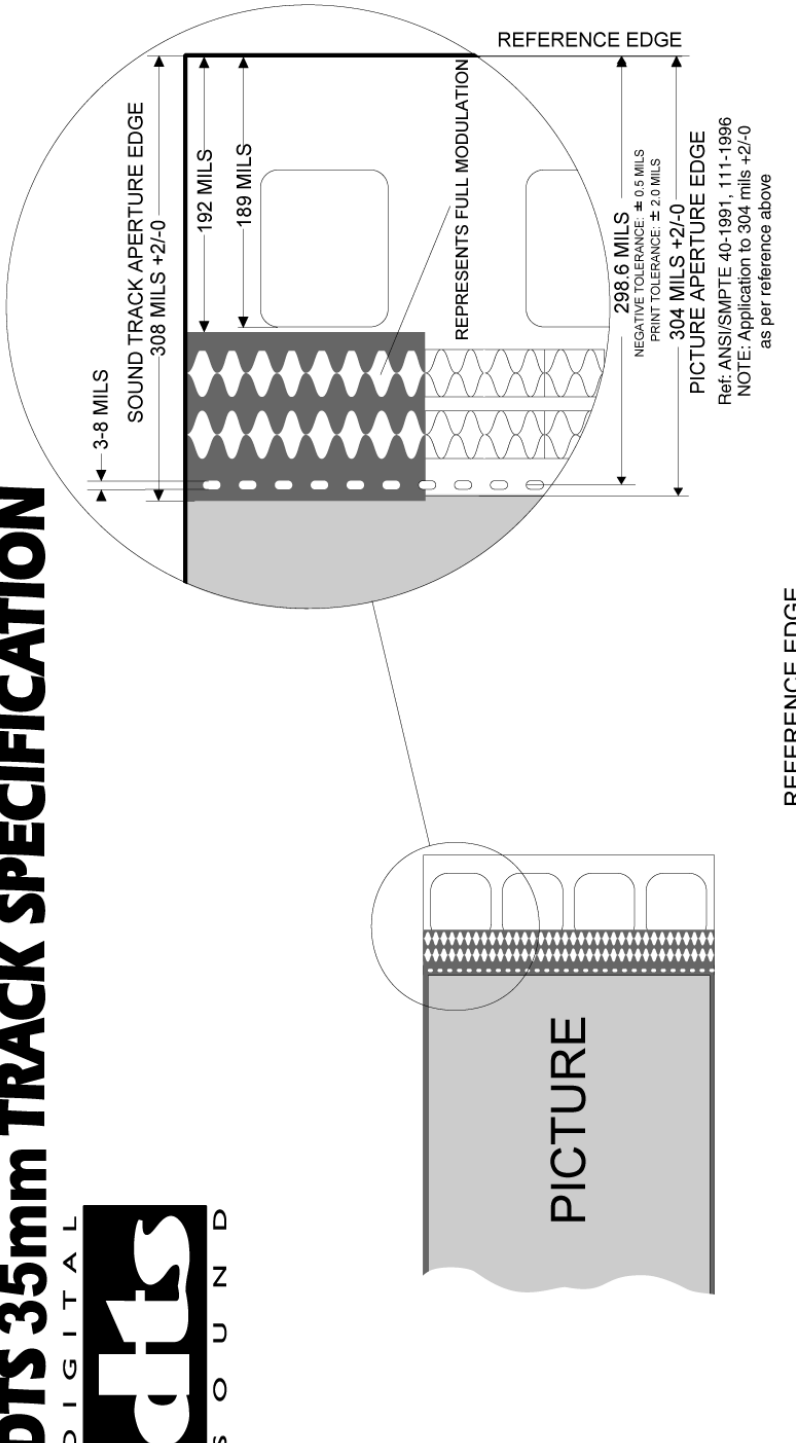
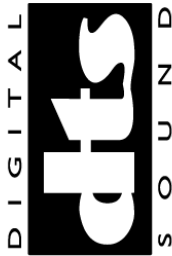

|  |                       |          |                   |
|--|-----------------------|----------|-------------------|
| TITLE: DTS 35 MM TRACK SPECIFICATION                                   |                       | APPROVED | DRAWN: J. DELARIA |
| DATE   | SCALE: NONE           | REV. A   |                   |
| DIGITAL SOUND  |                       |          |                   |
| DIGITAL THEATER SYSTEMS<br>5171 CLARETON DR.<br>AGOURA HILLS, CA 91301 |                       |          |                   |
| FILE NAME  | TIE243A (FILMSPEC)/AI |          | DWG. NO. TIE243A  |

PH: 818-706-3525 Fax: 818-706-1868  
 Revised: February 16, 2000

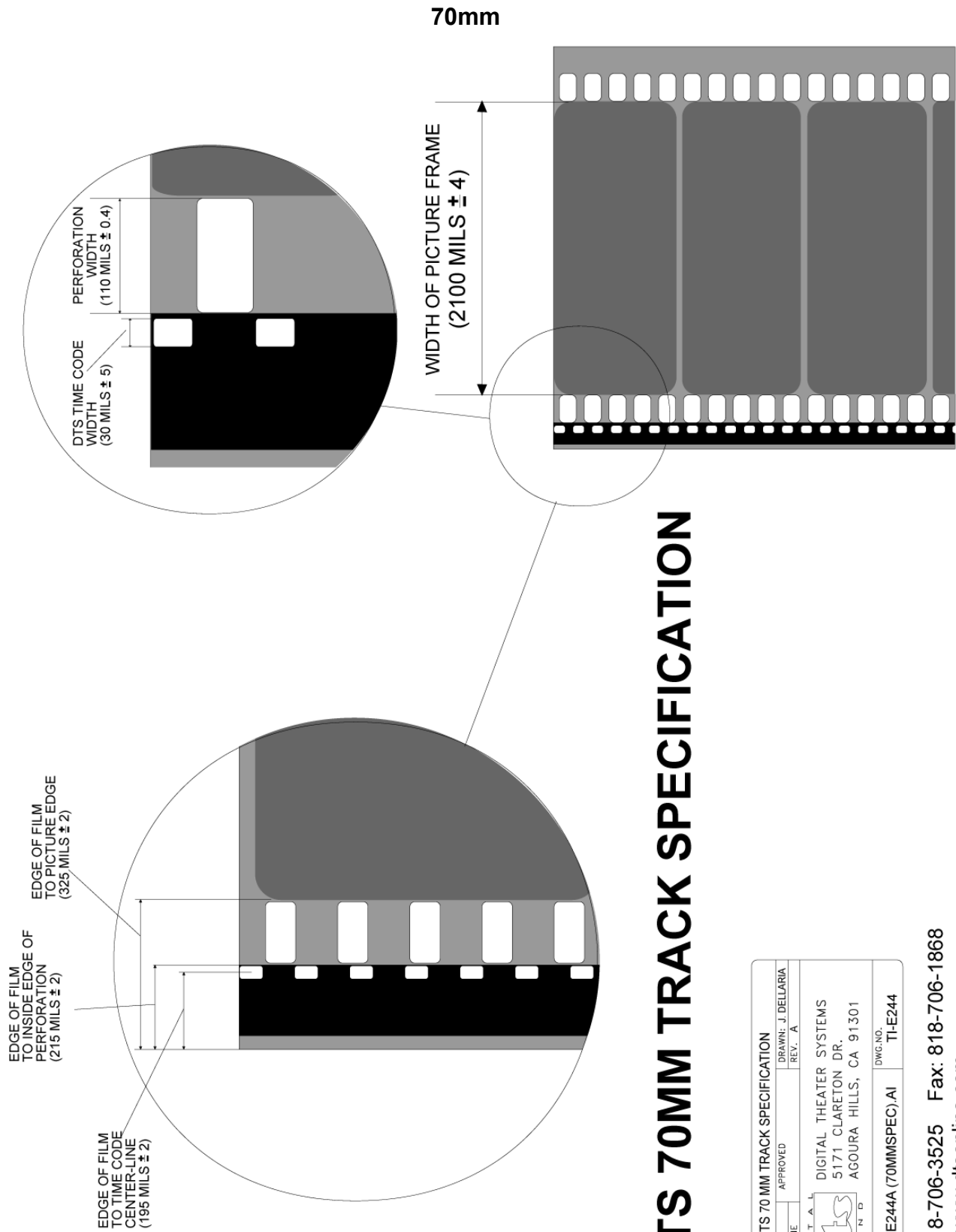

# DTS 70MM TRACK SPECIFICATION

PH: 818-706-3525 Fax: 818-706-1868  
 Web: [www.dtsonline.com](http://www.dtsonline.com)



## Appendix F. Video Option Installation

### F.1. XD10 Video Option

The XD10 Video Option enables the XD10 to output digital video to a digital projector. Typical uses may include theatrical pre-show material or special venue video presentations.

#### F.1.1. Field Installation for Type 1 Video Card

##### Required Components

1. DTS License for use of video option (a self-loading file on CD-ROM)
2. Video card
3. “Overlay” cable – provided with video card
4. Audio cable – short RCA Male to RCA Male provided with video card
5. Video cable to projector  
At the XD10 end this must be 15 pin male cable; the projector end can be either 15 pin (typically male), 3 BNC (RGB) or 5 BNC (RGBHV).
6. Projector (or monitor for test purposes)
7. If you are also using CSS (Cinema Subtitling) feature, extra hardware is required:
  - a. Video splitter (ATEN VS92A is available from DTS) with 12 VDC transformer
  - b. Extra Video cable (15pin VGA Male to female, 6 ft. length) (available from DTS)

##### F.1.1.1. Hardware Installation Procedure

1. Power down and unplug the XD10.  
 **Caution:** the XD10 front panel on/off switch does not remove power from the unit (it is a standby mode switch). The unit still has power to the PCI slots when this switch is OFF.
2. Remove XD10 cover.

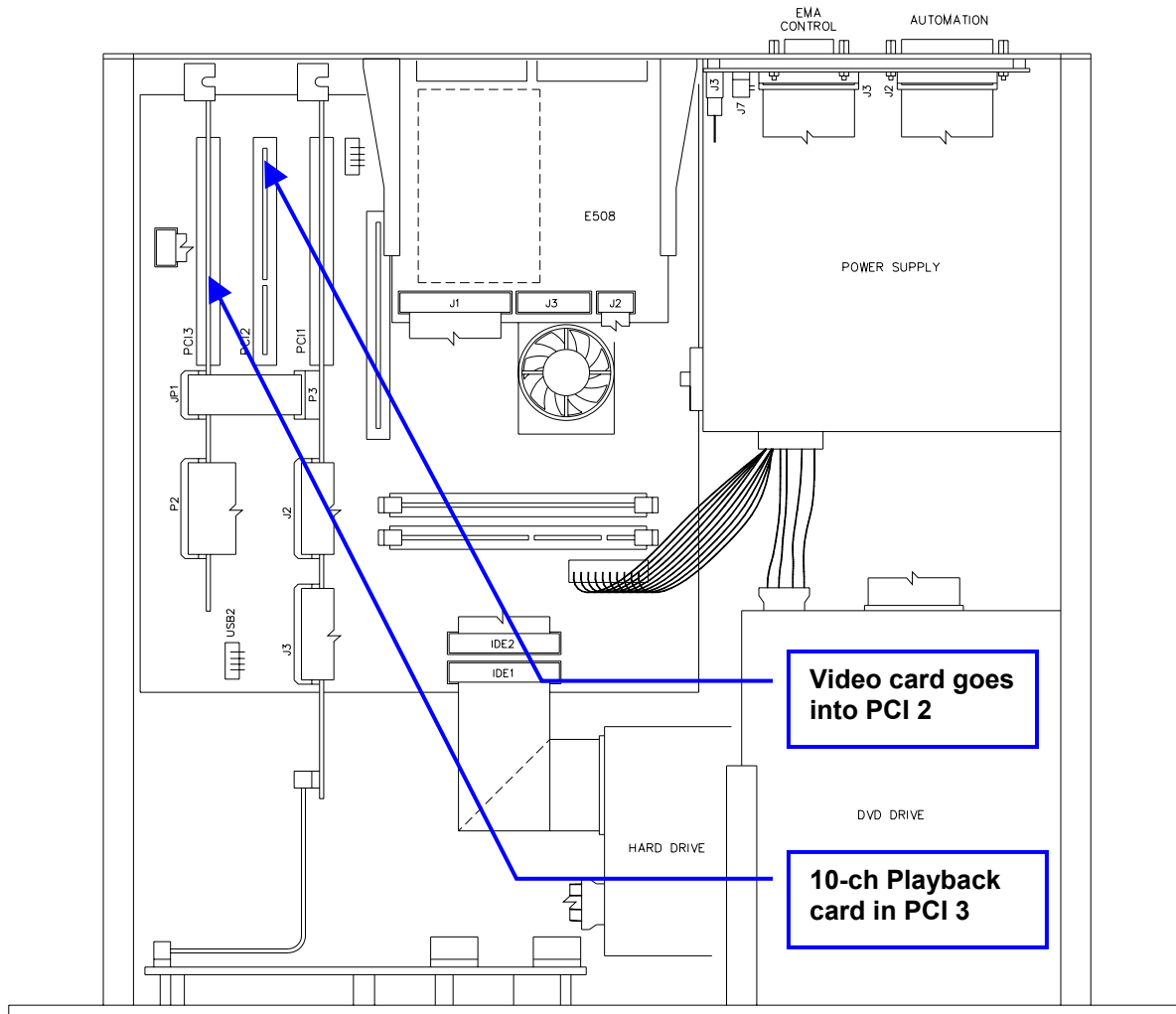

Figure F-1. XD10, Cover Removed

3. Remove the metal cover over the PCI slot that is second from the left side of the unit (Figure F-1, above). Keep the screw.
4. Discharge static by touching the XD10 chassis
5. Insert the video card in PCI slot. Make sure the card is firmly seated into the slot. Reinstall the screw.
6. Depending on whether you are using the CSS option:
  - a. If NOT using CSS, connect the “Projector Video” socket on the back of the XD10 to the 15 pin end of the “overlay cable”.
  - b. If using CSS, connect the “Projector Video” on the XD10 to “video in” on the splitter using the extra video cable (item 8.b under *Required Components*, previous page). Then install the 15 pin end of the “overlay cable” into the “video 1” output of the splitter. CSS connects to “video 2” output of the splitter. The splitter must be powered by the 12 VDC transformer (wall adapter) that is supplied.
  - c. In either case, connect the small end of the “overlay cable” to the “VGA IN” on the bottom of the video card, being especially careful to ensure a good connection.
7. Connect the audio cable from the video card’s “digital out” to the input marked “VID” on the 10-ch Playback card in PCI 3 (the card nearest the left side in Figure F-1, above).



8. Connect the projector to the “VGA out” output of the video card (or use a monitor for test purposes).
9. Reinstall the XD10 cover.
10. Connect the XD10 to the cinema processor.
11. Plug in the unit
12. Reinstall the unit in the rack.

### F.1.2. Enable / Test Procedure

1. Power up the projector (or monitor) and adjust cinema processor levels to low.
2. Power up the unit. You should see computer text on the projector as it boots. (If not, see Debug Procedure, below.)
3. Enable the video feature by installing the license CD in the XD10 DVD drive.
4. The unit will boot up into “test mode” since no other video has yet been loaded.
5. Hit ENTER to access menus. Test hardware by going to Playback | Video | Play Menu | Play.

There is a test clip already on the hard drive, provided with the unit. Wait for the software to load before the test clip begins playing. You should see the “DTS Playback” and “VIDEO” LEDs are lighted, indicating that the unit is playing video. At that point you should see video on your projector or monitor, and hear audio through the Cinema Processor.

### F.1.3. Debug Procedure

| Symptom   | Action   |
|---|--|
| No video (either computer text during boot or video while LEDs are lighted) | Power off the unit and ensure that the video cable into the “VGA IN “ on the video card is connected securely. The unit must be rebooted (the connection must be good when the XD10 boots up). |

### F.1.4. Configuration Procedure

1. In the System Setup | Video Setup | Set Application menu, choose Common Height or Common Width.
2. Calibrate the video overlay by playing the test file. Enter test mode by System Setup | Video Setup then choose Set Test | Normal.
  - a. Go to System Setup | Video Setup | Set Video | Cal Width and adjust width so that the right edge of the motion video is aligned with the edge of the projector output.
  - b. Go to System Setup | Video Setup | Set Video | Cal Location and adjust location so the left edge aligns with the left edge of the projector output.
  - c. Repeat steps (a) and (b) until the image aligns horizontally.
3. Set the output resolution for best image quality.

Setting the XD10 output resolution to match the video projector’s native resolution (1024x768 or 1280x1024) gives the best results. In this case the projector should be set to “native” (or similar term to indicate no scaling). On the XD10, go to System Setup | Video Setup | Set Video | Resolution. After a change, some projectors need to be restarted in order to re-sync.

4. Adjust Brightness and Contrast from System Setup | Video Setup | Set Video menus.



5. Set Player Zone from System Setup | Video Setup | Set Video | Set Player Zone menu, if needed. This may be left at the default of Zone 00 to display all content.

#### **F.1.4.1. Restore Factory Defaults**

There are various settings for the video that are initially set to factory defaults. These can be restored – go to Main Menu | System Setup | Video Setup | Factory Settings and choose **Restore Video Default**.

## Appendix G. Cinema Subtitling System (CSS) Option

The DTS Model DTS-CSP subtitle projector can be mounted in the projection booth or in the auditorium. For most theaters, it will be in the projection booth. It is used to project subtitles that are supplied by the XD10 software. The subtitle video is downloaded into the XD10 from a “show disc.” Then the operator chooses the language desired for the subtitles, from the Playback | CSP Language menu, or chooses Automation to automate the subtitles selection process. Once the film is started, the correct subtitles are projected in sync with action on-screen.

Along with the DTS-CSP, there is a special external mask assembly DTS-EMA and its mounting hardware.

- The DTS-EMA consists of a bracket, douser, cooling fan, and adjustable magnetic trims. (See parts lists in Appendix A.)
- The mounting hardware consists of a mounting plate, shaft, and clamp. The mounting plate attaches directly to a wall or ceiling, and the clamp attaches directly to the DTS-EMA. (See parts lists in Appendix A.)

### G.1. DTS-CSP Subtitle Projector

|                                      |  |
|--------------------------------------|--|
| Available Projectors                 | DTS-CSP (for throws up to 50 feet, standard “short throw”)<br>DTS-CSPL1 (for throws up to 120 feet, “long throw”)                                  |
| Physical Dimensions                  | Height: 4 inches (10.16 cm)<br>Width: 9 inches (22.86 cm)<br>Depth (short throw): 12 inches (30.48 cm)<br>Depth (long throw): 14 inches (35.56 cm) |
| Weight (projector only, short throw) | 6.0 lbs. (2.72 kg)   |
| Weight (projector only, long throw)  | 8.0 lbs. (3.63 kg)   |
| Operating Case Touch Temperature     | 194° F (90° C)   |
| Power Requirements                   | 100 to 240 VAC, at 50 to 60 Hz   |
| Power Consumption                    | 400 watts  |
| Lamp Replacement                     | Every 1400 hours (Lamp module Part # 1802 0001 00)   |

#### G.1.1. Projector Air Space Requirements

To avoid overheating of the projector, adequate airspace is required. Six inches (15.24 cm) are required on all sides (left, right, front, and rear) and 12 inches (30.98 cm) is required above and below.

- Note:** All projector vents and the external blower must NOT be obstructed in any way, to ensure free airflow for cooling.

### G.2. DTS-EMA Mounting

**DTS-EMA** external mask assembly / mount adapter PN 9001DEMA00A includes the external mask assembly and mount adapter, which attach to the projector, and the hardware that attach the projector and EMA to the projection booth wall or ceiling.

**Short throw DTS-EMA Part # MD00DEMA02**

Physical Dimensions    Height: 8 inches (20.32 cm)  
                                  Width: 7 inches (17.78 cm)  
                                  Depth: 19 inches (48.26 cm)  
                                  Weight (without projector) 3.3 lbs. (1.5 kg)

**Long throw DTS-EMA Part # MD00DEMA03**

Physical Dimensions    Height: 9.5 inches (24.13 cm)  
                                  Width: 11.5 inches (29.21 cm)  
                                  Depth: 22 inches (55.88 cm)  
                                  Weight (without projector) 3.7 lbs. (1.68 kg)

**Mounting Hardware for the DTS-EMA**

Bracket Part # 9120E57301D    16 inches long (40.60 cm)

                                  Weight: 3.5 lbs. (1.6 kg)

Arm, 6" long (15.94 cm), Part #5005000300    Weight: 1.7 lbs. (0.77 kg)

Arm, 12" long (30.48 cm), Part #5005000400    Weight: 2.2 lbs. (1.0 kg)

Arm, 18" long (45.72 cm), Part #5005000500    Weight: 2.7 lbs. (1.22 kg)

Wall Mounting Plate\* Part #9120E61000B    Dimensions: 6 by 8 inches (15.24 cm by 26.32 cm)

                                  Weight: 1.4 lbs. (0.34 kg)

Mount Capacity: Mount is rated for objects weighing up to 55 lbs. (25 kg)

- \*Wall Mounting Plate Fasteners requirement: Quantity: Four (4).  
Size: Larger than ¼ inch (6mm) to maximum 5/16 inch (8mm).  
Type depends on wall composition.  
Wall fasteners NOT supplied by DTS.

**Replacement Parts: DTS-EMA, External Masking Apparatus – see Appendix A.**

### G.3. DTS-EMA Assembly

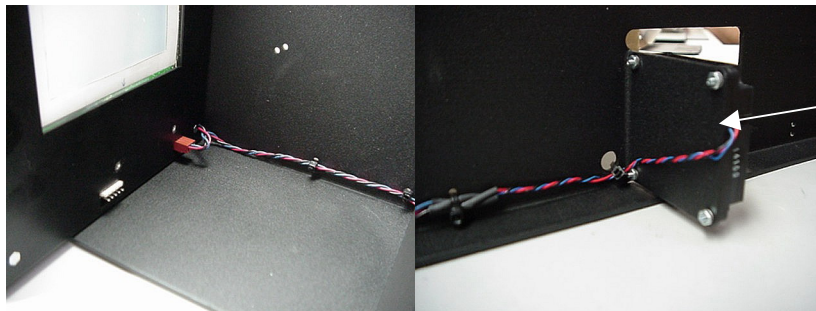

Replacement mask trims are available. Please specify size and part numbers.

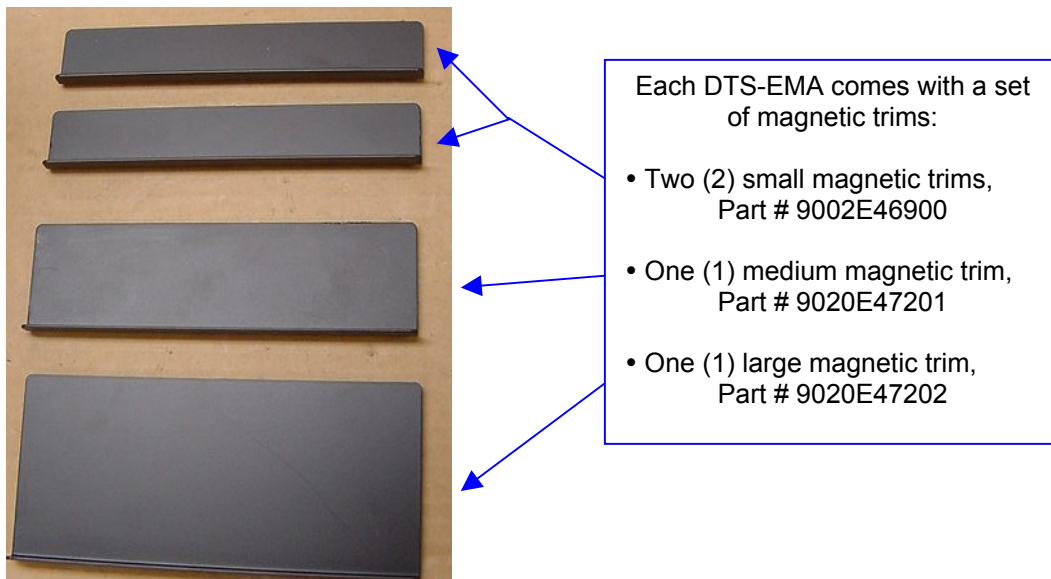



Wall mounting plate, Part # 9120E61000B.  
Comes with thumb nut (M6), Part # 1007M6010.

Bracket (shown attached to arm). Part # 9120E57301D.

Arm, three different lengths available. Choose the one appropriate for installation.

See "DTS-EMA Vertical Drop Mounting Guide" (next page) for help in choosing correct arm length.

Three arm choices (choose one).



Three arm length choices:

6" (15.94 cm)  
Part # 5006000300

12" (30.48 cm)  
Part # 5006000400

18" (45.72 cm)  
Part # 5006000500

Hardware included with each arm.



Each arm comes with:

- Two (2) nuts (16mm w/ 2mm pitch)
- One (1) lock washer, 16mm
- Three (3) metric screws (M6 X 12mm, Phillips oval head)



## G.4. DTS-EMA Vertical Drop Mounting Guide

### EMA VERTICAL DROP MOUNTING GUIDE - 6" ARM (DTS P/N 5006000300)

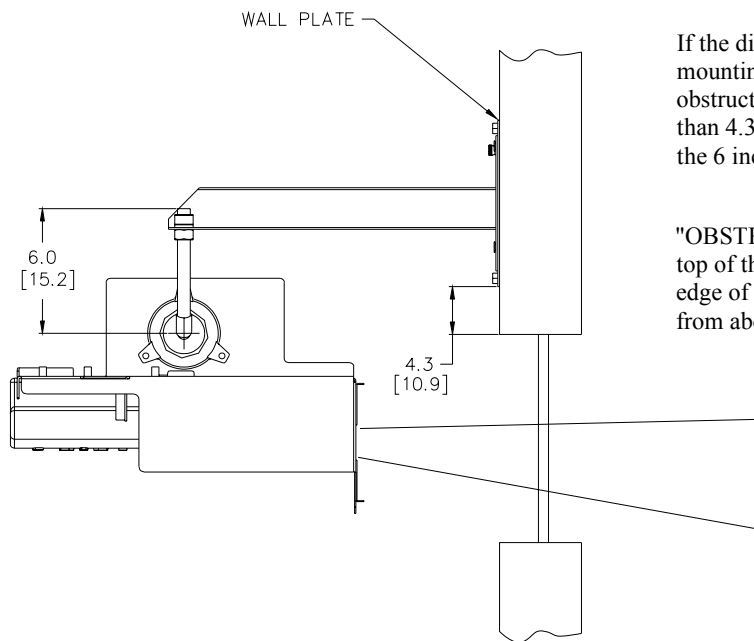

If the distance from the bottom of the wall mounting plate to the bottom of the obstruction in the port window is no more than 4.3 inches (10.9 cm), then you can use the 6 inch arm.

"OBSTRUCTION" is defined as the top of the port opening, the bottom edge of a fire door that slides down from above, etc.

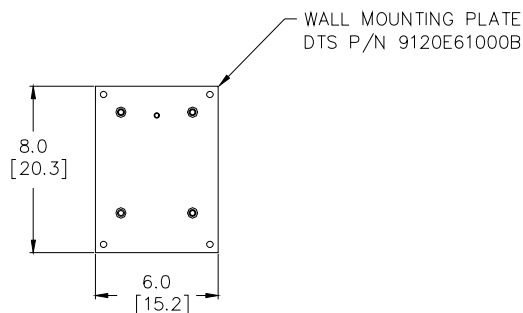

Dimensions in [ ] are in centimeters. All other dimensions are in inches.

The next three drawings can be used to determine which arm length to use in your EMA installation.

## EMA VERTICAL DROP MOUNTING GUIDE - 12" ARM (DTS P/N 5006000400)

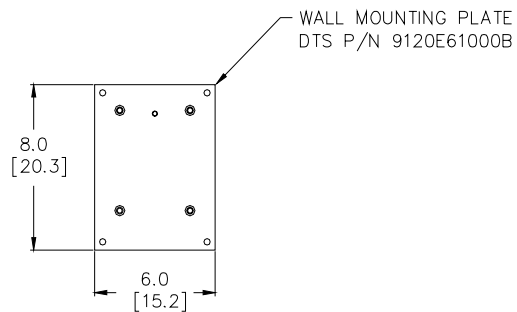
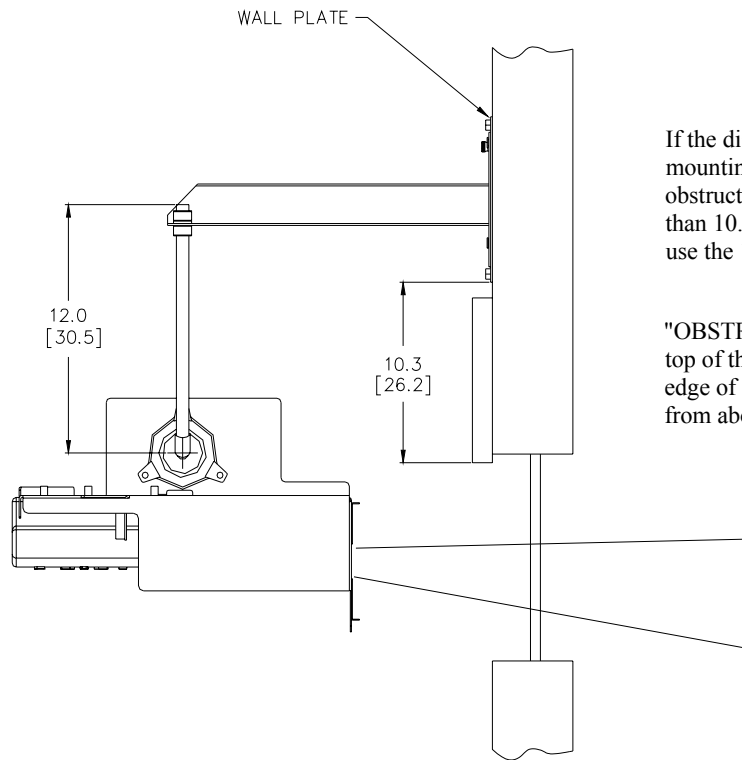

Dimensions in [ ] are in centimeters. All other dimensions are in inches.

## EMA VERTICAL DROP MOUNTING GUIDE - 18" ARM (DTS P/N 5006000500)

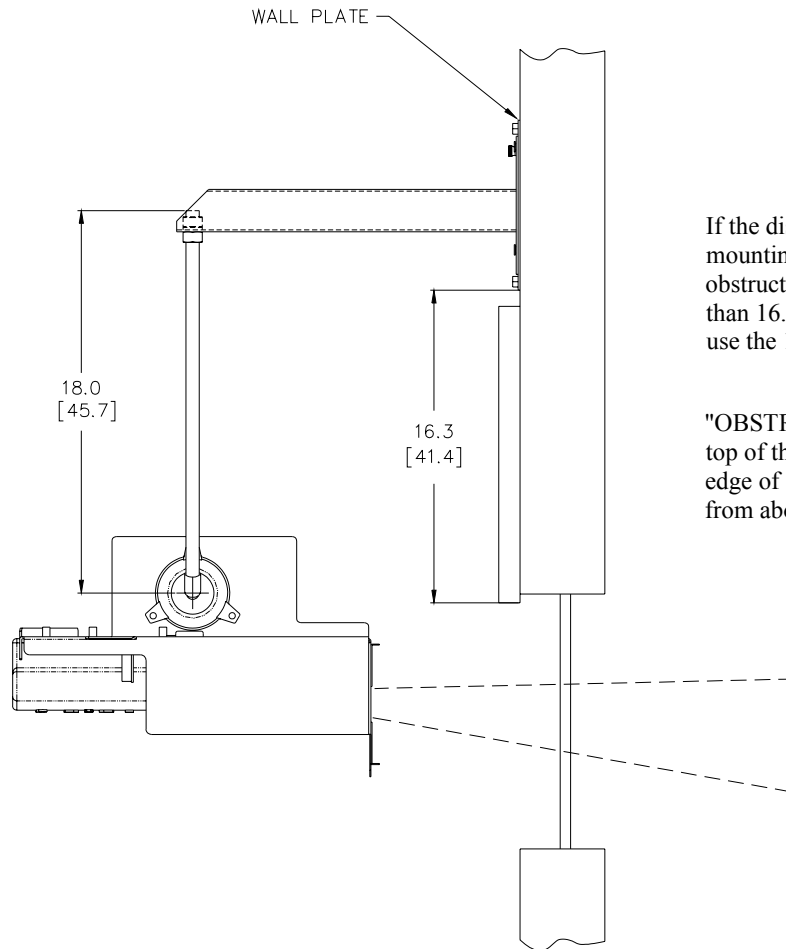

If the distance from the bottom of the wall mounting plate to the bottom of the obstruction in the port window is no more than 16.3 inches (41.4 cm), then you can use the 18 inch arm.

"OBSTRUCTION" is defined as the top of the port opening, the bottom edge of a fire door that slides down from above, etc.

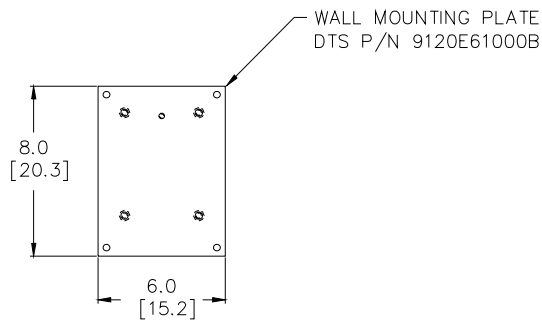

Dimensions in [ ] are in centimeters. All other dimensions are in inches.

## G.5. Subtitle Projector Installation

The subtitle projector installation consists of two pieces of hardware: ① Projector (DTS-CSP), ② external mask assembly (DTS-EMA), which includes hardware for mounting to the projector booth wall or ceiling. Most installations will occur in the projection booth. If no other alternative exists, the projector may be installed in the auditorium.

- ☑ **Note:** The DTS-CSP Subtitle Projector **MUST** be installed upside down.
- ☑ When installing projector, ensure there is easy access for cleaning the lens and changing the lamp.
- ☑ An assistant is needed to help hold the projector when it is attached to the mount.

### G.5.1. Installation Tools

|                      |                                |
|----------------------|--------------------------------|
| Adjustable wrench    | Drill with ¼ inch (6.3 mm) bit |
| Various screwdrivers | Hex driver 5/32 inch (13.1 mm) |
| 16 mm socket wrench  |                                |

### PRECAUTIONS

It is the installer's responsibility to evaluate the area selected for mounting the DTS-CSP projector. Special care must be taken when mounting the projector to the wall. The correct fasteners and a wall rated to support 25 lbs. (9 kg) must be chosen. The composition and strength of the wall must be evaluated so that the proper fasteners are used. Adequate reinforcement should be added if the wall is not strong enough. Consultation with a carpenter is highly recommended. Also, when not using the DTS mount, consult a carpenter to construct appropriate mounting for the DTS-CSP.

To avoid overheating of the projector, adequate airspace is required. Six inches (15.24 cm) are required on all sides (left, right, front, and rear) and 12 inches (30.98) is required above and below.

A second person is necessary to hold and support the projector in place during the tightening procedure.

Failure to follow the procedure set forth in this manual will void the warranty, if any, provided by DTS with respect to the DTS-CSP subtitling projector.

The installer shall be responsible for any injury or damage resulting from installer's failure to follow procedure set forth in the manual, and DTS shall have no responsibility what-so-ever for any injury or damage resulting from installer's failure to follow procedure set forth in this manual.

### G.5.2. Installation Procedure

Use this procedure to install the subtitle projector into the projection booth.

1. Verify you have all hardware needed for the DTS-CSP installation.
  - One DTS-EMA mask/mount adapter and one DTS-CSP subtitle projector.
  - One bracket, wall mounting plate, and arm for mounting the CSP/EMA to the wall.
2. Assemble the bracket and arm to the DTS-EMA.
  - a. Connect the arm assembly to the DTS-EMA. Place mounting foot so that arm can pivot upward.

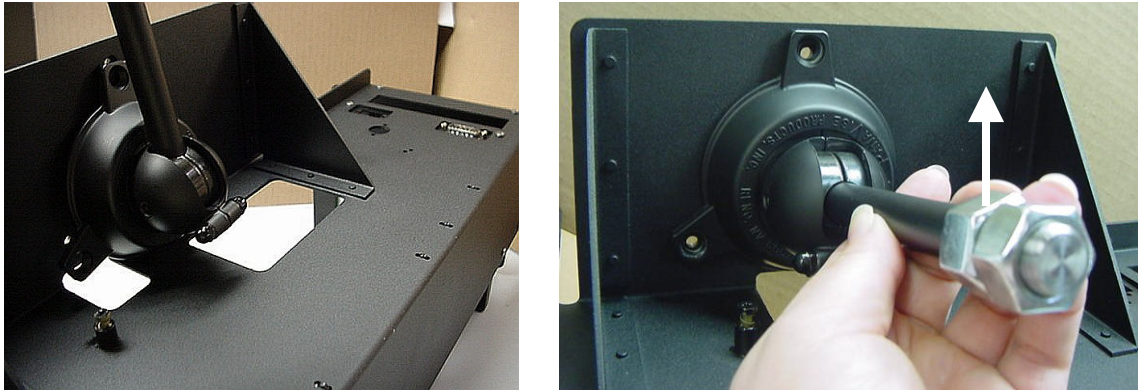

Figure 1. Arm must pivot upward, when mounting foot is attached to EMA.

- b. Secure mounting foot to EMA chassis using the 3 metric (M6) screws (Figure 2).



Figure 2. Secure mounting foot to EMA chassis

- c. Tighten setscrew to tighten arm in foot using 5/32 inch (13.1 mm) hex driver.
  - The 3 metric oval-head Phillips screws may seem difficult to insert. This is because the 3 nuts on the EMA are elliptical, not round, to provide greater retention force. Because of the greater force required for insertion, be careful not to cross-thread the screws.

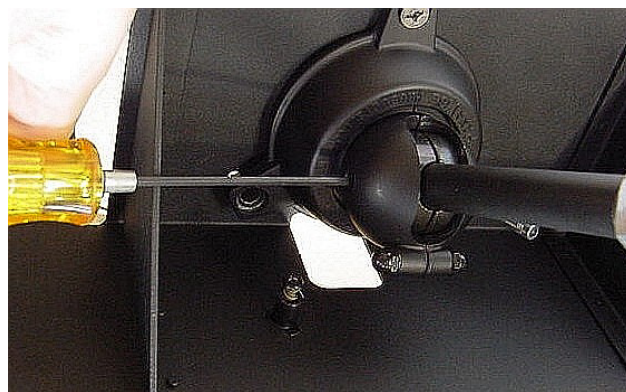

Figure 3. Tighten setscrew.

- d. Using the hardware provided, connect the arm to the support bracket.

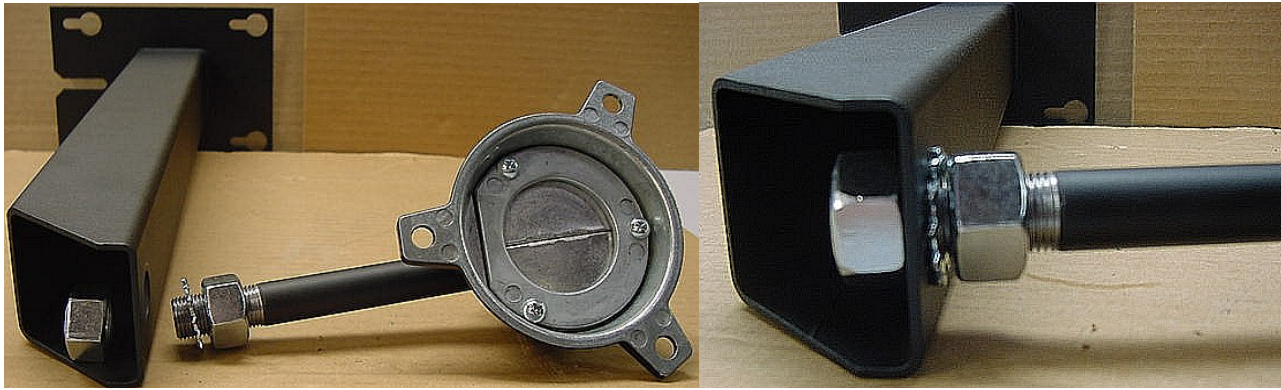

Figure 4. (Before/After) Connect the arm to the support bracket.  
(EMA shown not attached.)

3. Connect the projector to the DTS-EMA assembly. Secure using the three captive Phillips screws (see arrows, Figure 5).

The projector must be installed upside down.

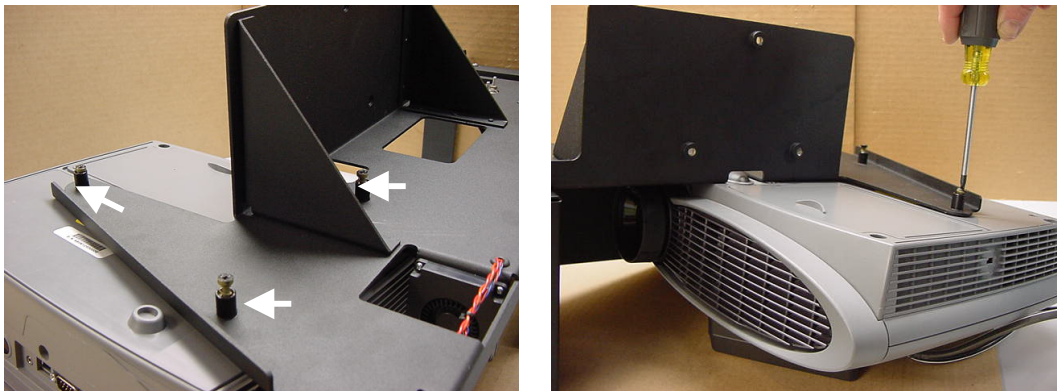

Figure 5. Secure the projector to the EMA.

4. Install the mounting plate on the wall, above the porthole.
  - a. While one person holds the mounting plate to the wall, a second person will support and position the DTS-EMA assembly. Turn on the projector lamp, then position the projector and external mask so that the image on screen is in the correct position.

**⚠ Warning:** Do not look directly into the projector light aperture.

- b. You may want to loosen and re-tighten the set screw (step c, above) in the movable clamp, to adjust projector position. Be sure to tighten the arm attachment (step d, above) once the correct position is determined. Then turn off the projector.
  - c. Mark the wall for placement of the mounting plate. Mark the location of the 4 screw-holes for the fasteners.

The Mounting Plate is 6 inches long (15.24 cm) and 8 inches tall (26.32 cm). It must be mounted vertically, as shown in Figure 6.

To secure the EMA mounting system to a wall made of dry wall, sheet rock, gypsum, or plaster, it is required to first mount a ¾ inch thick (19 mm) minimum plywood base onto the wall, to provide solid support for the EMA mounting plate. The plywood base shall be securely attached to the structural members (wood or steel supports) of the wall. Then attach the EMA mounting plate to the plywood base.

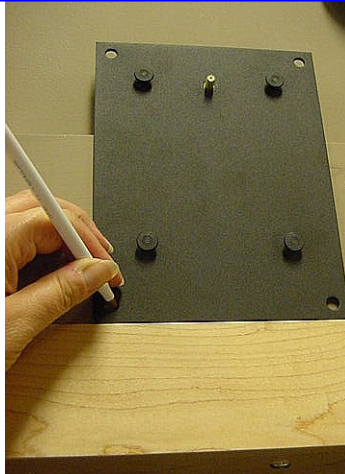

Figure 6. Mark mounting plate location and screw hole locations.

- d. Drill pilot holes at the markings for the fasteners. The drill bit must be smaller than the diameter of the fastener used.

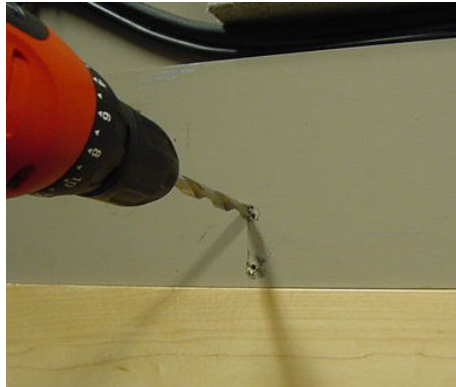

Figure 7. Drill pilot holes for mounting plate fasteners.

- e. With four (4) proper fasteners, secure mounting plate to wall. (See figure 8.)  
Fastener size should be larger than ¼ inch (6 mm) to maximum 5/16 inch (8 mm). Since the type of fastener depends on the material used in the wall, DTS does not provide these fasteners.

**⚠ Caution:** Over-tightening the fasteners can weaken the mounting surface, damage the fasteners, and make the attachment less secure.



Figure 8. Secure mounting plate to wall.

5. Attach the assembly to the mounting plate, with the help of an assistant. (See figure 9.)
  - a. Inspect the installation to be sure that the mounting plate is secured to the wall and that the assembly is secured to the mounting plate.
  - b. Tighten the metric thumb nut (M6) to secure bracket to wall plate (see arrow, Figure 9).

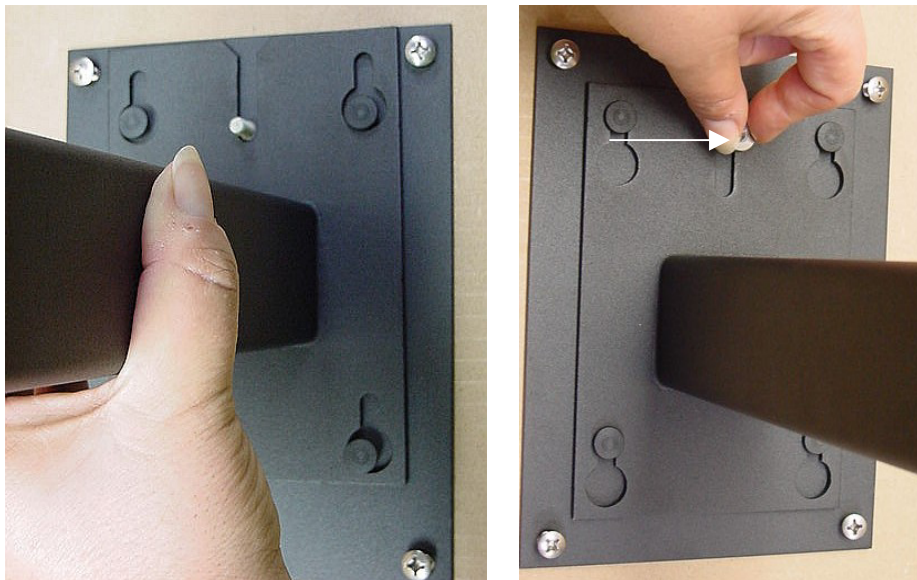

Figure 9. Attach the assembly to the wall mounting plate.

**⚠ Caution:** All DTS-CSP vents and the DTS-EMA fan must not be obstructed in any way.

6. Connect cables from the DTS-XD10 to the DTS-EMA and DTS-CSP.

Separate the power cable from the data cables. Do not route them bundled together. Ensure data cables are not routed next to power sources or fluorescent lights. The EMA cable goes to **EMA Control** connector on the XD10. The Projector cable goes to **Projector Video** connector on the XD10.





Figure 10. Connect cables.

As a safety precaution, the addition of a safety cable to secure the DTS-EMA is highly recommended. In case of earthquake or mounting plate failure, the projector assembly will be prevented from falling to the floor. Use any spare hole on the DTS-EMA to secure the assembly to the ceiling or wall.

### G.5.3. Programming the DTS-CSP Subtitle Projector

1. Remove the lens cap and press the green ☀ POWER button to power on the projector.
2. Verify Lamp Life Counter.
  - a. On the DTS-XD10, press the ENTER button to access the MAIN menu.
  - b. Press the ▼ button and scroll to PLAYBACK, then press the ► button.
  - c. Once in PLAYBACK menu, press the ▼ button and scroll to CSP LAMP STATUS.
  - d. Press the ► button to view lamp life hours. It should be at zero [0]. If not at zero, see the topic *Reset the Lamp Hour Counter* on page A-G-20 to reset the counter.
  - e. Press ENTER button to save selection and return to the main screen.
3. Set the Douser type of the projector.
  - a. From the XD10 MAIN menu, press the ▼ button and scroll to SETUP. Press the ► button.
  - b. Once in SETUP, press the ▼ button and scroll to CSP SETUP. Press the ► button.
  - c. Once in the CSP SETUP, press the ▼ button and scroll to OPTIONS. Press the ► button and select DOUSER TYPE.
  - d. Once in DOUSER TYPE, press the ▼ button to scroll to “Electronic” (unless your douser is the older mechanical model, in which case you should choose “Mechanical”). Press ENTER button.
  - e. Press the ▼ button and scroll to EXIT. Press ENTER button to save selection and return to the main screen.
4. Set the Light Intensity of the projector.
  - a. From the XD10 MAIN menu, press the ▼ button and scroll to SETUP. Press the ► button.

- b. Once in SETUP, press the ▼ button and scroll to CSP SETUP. Press the ► button.
  - c. Once in the CSP SETUP, press the ▼ button and scroll to OPTIONS. Press the ► button and select LIGHT INTENSITY.
  - d. Once in LIGHT INTENSITY, press the ▼ button to scroll to “High”. Press ENTER button.
  - e. Press the ▼ button and scroll to EXIT. Press ENTER button to save selection and return to the main screen.
5. Check the Light Output of the projector.
- a. From the XD10 MAIN menu, press the ▼ button and scroll to SETUP. Press the ► button.
  - b. Once in SETUP, press the ▼ button and scroll to CSP SETUP. Press the ► button.
  - c. Once in the CSP SETUP, press the ▼ button and scroll to TEST PATTERNS. Press the ► button.
  - d. Once in TEST PATTERNS, use the ▼ button to scroll to White. Press ENTER.
  - e. Verify the DTS-EMA shutter automatically opens.
  - f. Using a light meter, measure the light reflected off the screen. Use the table below.

| Distance from screen  | “Normal” power (DTS-CSP) |
|-----------------------|--------------------------|
| 20 Ft. (6.1 meters)   | 32 to 26 FL              |
| 30 Ft. (9.1 meters)   | 14 to 11 FL              |
| 40 Ft. (12.2. meters) | 8 to 6.4 FL              |
| 50 Ft. (15.2 meters)  | 5 to 4 FL                |

- g. Return to TEST PATTERNS and this time choose EXIT. Press the ENTER button. Verify the DTS-EMA shutter automatically closes.
6. Adjust the Subtitle Picture Quality.
- a. While in TEST PATTERNS, press ▼ button and scroll to FULL SCREEN. Press the ENTER button.
  - b. Remove any screen masking.
  - c. Once test pattern is on the screen, adjust the projector zoom and focus.
    - 1. Adjust projector zoom in or out by rotating the zoom ring. The test grid pattern should fill the entire screen. It should be level, centered and extend to both sides of the screen.
    - 2. Adjust projector focus by rotating the focus ring. The text grid pattern should have crisp edges and be easy to read.

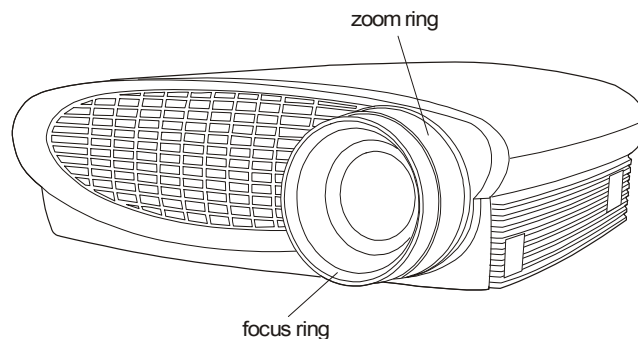

Figure 11. Zoom and Focus Adjustment

7. Aim the DTS-CSP Subtitle Projector (with screen masking removed).
  - a. From the XD10 MAIN menu, press the ▼ button and scroll to SETUP. Press the ► button.
  - b. Press the ▼ button and scroll to CSP SETUP. Press the ► button.
  - c. Once in the CSP SETUP, press the ▼ button and scroll to TEST PATTERNS.
  - d. Once in TEST PATTERNS, use the ▼ button and scroll to **Full Screen**. Press ENTER button.
  - e. Verify the test grid pattern is centered on the screen. It should encompass the entire screen area. If horizontal adjustment is necessary, continue to step f. If vertical adjustment is necessary, do step g. Otherwise, skip to step h.
  - f. Horizontal Offset is adjusted by physically moving the projector in its mount. The pattern shown for vertical offset (next step) is useful for setting the horizontal position. The center vertical line of the pattern should be located on the center of the screen.
  - g. To adjust Vertical Offset, from the CSP SETUP menu, select **Vert. Offset**. Use ► and ◀ to adjust while observing the test pattern projected on the screen. When satisfied, press ENTER button.
  - h. Now, go back into TEST PATTERNS and this time choose **View Area**. Press ENTER button.
  - i. You have two choices: Horizontal View Area -or- Vertical View Area. Choose the one that matches the subtitle format used by the theater.
  - j. Verify the white box test pattern covers the intended “subtitle area” shown below.
    - The DTS-CSP subtitle projector must be installed upside down, as shown below.

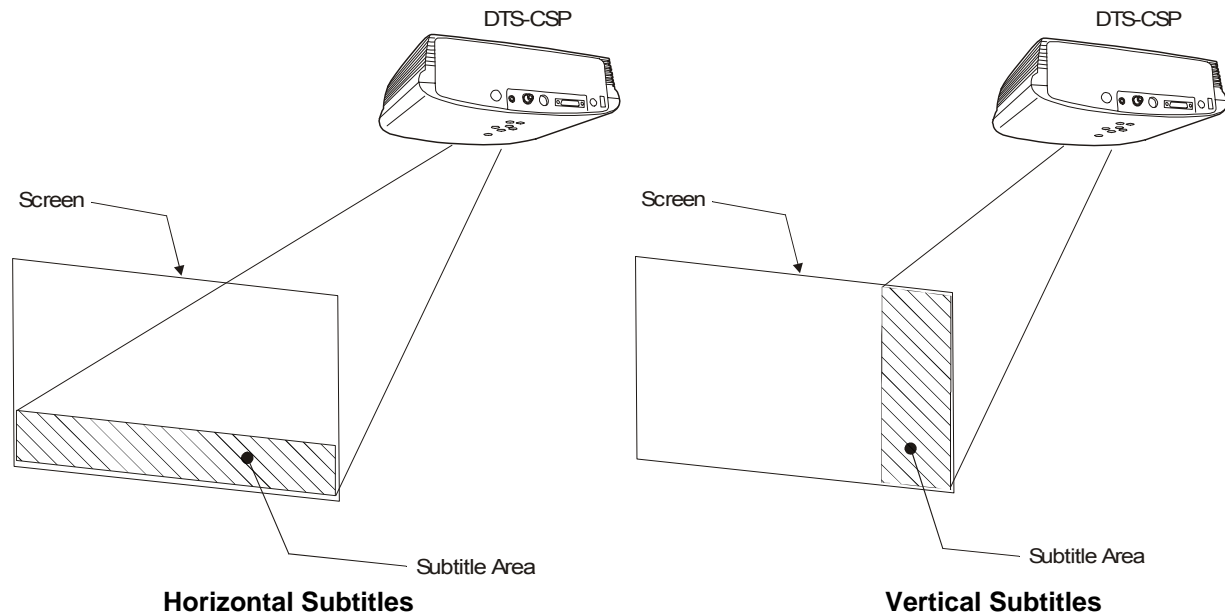

Figure 12. Horizontal and vertical subtitle areas.

### G.5.4. Position the DTS-EMA Mask Trims (with screen masking added)

You can position the subtitles to display vertically or horizontally on the screen. The projector must be setup for one or the other, not both. (See step 6 on the previous page.) The magnetic trims are used to block out any extraneous light at the DTS-EMA. You will receive one large, one medium, and two small trims. Position them as needed so that only the intended “subtitle area” is lit by the test pattern.

#### G.5.4.1. Vertical Subtitles

1. While in TEST PATTERN, press ▼ button and scroll to **View Area**. Press ENTER button. Choose **Vertical View Area**.
2. Add screen masking. The white box test pattern should be seen in the vertical subtitle area, as shown below. Adjust the DTS-EMA magnetic trims to block out any extraneous light.

#### G.5.4.2. Horizontal Subtitles

1. While in TEST PATTERN, press ▼ button and scroll to **View Area**. Press ENTER button. Choose **Horizontal View Area**.
2. Adjust the DTS-EMA magnetic trims so that white box test pattern fits in the horizontal subtitle area.

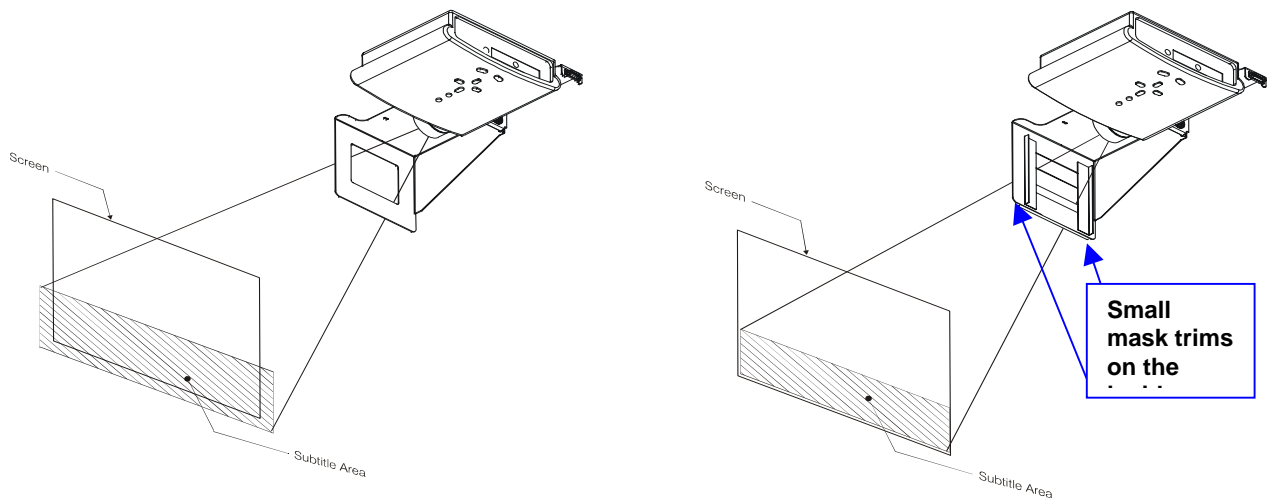

Figure 13. Before (left) and after (right) positioning magnetic trims. (View is looking upward at bottom of projector.)

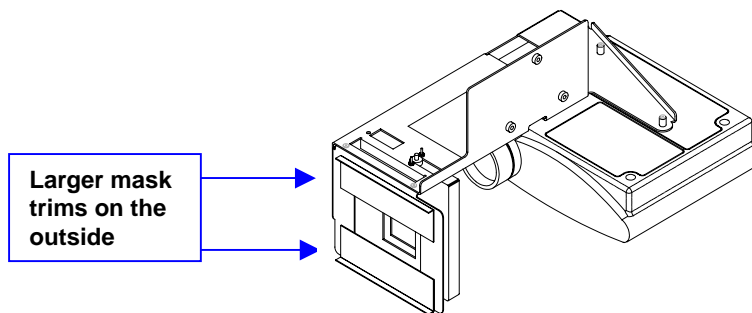

Figure 14. Large mask trims used on the outside of the EMA Mask. (View is looking downward at top of projector.)

## G.6. Regular Maintenance of the DTS-CSP System

Routine maintenance of the subtitle projector consists of keeping the lens free of dust and inspecting the projector lamp.

The DTS-CSP subtitle projector lamp must be changed after 1400 hours of use. Failing to change the lamp after 1400 of in-use hours may result in damage to the projector and is not covered by warranty.

The XD10 CSS Lamp Fault red LED will flash, when 1400 in-use hours has been reached. The same indicator will light continuously to indicate that the lamp has failed.

### G.6.1. Routine Projector Lamp Maintenance

**After every 100 hours of use**

 **Warning:** Wait for the projector lamp to cool, before inspecting and cleaning the lamp module. A hot projector lamp can cause serious personal injury.

1. Vent screens on the module must be inspected. Any accumulated material (lint, dust, smoke residue, etc.) must be carefully removed with a gentle vacuum cleaner or canned air and a soft brush.

**Note:** If a large accumulation of dirt is observed, the inspection interval time should be shortened with the objective of maintaining clean screens and vents.

2. Inspect the lamp bulb for any of these factors, and (if found) replace lamp:
  - bulging
  - white cloudy appearance
  - blackened bulb
  - bulbs with separated ceramic collars
3. The lamp module must be replaced after 1400 hours of use.

 **Caution:** The lamp module must NOT be modified in any way. If the cover glass is missing, removed or damaged, the unit will be damaged by excessive heat (and the warranty will be void). Blocked or damaged lamp module screens can reduce lamp life or increase the possibility of rupture containment failure.

### G.6.2. Lamp Module Dust Filter Screen

**After every 200-250 hours of use, in dirty environments**

In dirty or dusty environments, the lamp module dust filter screen in the DTS-CSP projector can become plugged, causing excessively high temperatures inside the lamp module. Excessively high temperatures can cause premature lamp failure. Routine maintenance to remove dust and dirt from the filter screens lowers the lamp operating temperature and lengthens lamp life. Clean the lamp module dust filter screen every 200-250 hours when the projector is used in areas with high levels of airborne contaminants like lint, dust or smoke. See TN-E538 in *Appendix H* of this manual.

### G.6.3. Projector Lens Cleaning

The projection lens should be inspected regularly and cleaned by the approved cleaning method (soft non-abrasive cloth and mild glass cleaner). If the projector will not be used for a long period, cover lens with lens cap.

1. Apply a non-abrasive camera lens cleaner solution to a clean, soft, dry cloth.

**⚠ Caution:** Use cleaner sparingly – do not use too much. Do not apply cleaner directly to the lens (instead, apply to the cloth). Do not use abrasive cleaners, solvents or other harsh chemicals that may scratch the lens.

2. Lightly wipe the cleaning cloth over the lens in a circular motion.
3. Verify the focus and zoom adjustments after cleaning is finished.

## G.7. Replacing the Lamp Module

**⚠ Warning:** To avoid burns, allow the projector to cool for at least 30 minutes before you open the lamp module door. Never extract the lamp module while the projector is operating.

**⚠ Warning:** To avoid eye injury, do not look directly into the projected light beam.

The lamp hour counter in the CSP Lamp Status menu displays the number of hours the lamp has been in use. Change the lamp when the brightness is no longer acceptable or after 1400 hours. The XD10 front panel features a CSP Lamp Fault indicator that will flash (red) when the lamp needs replacing. The indicator will light continuously (not flashing) in case of lamp failure.

The lamp must be changed at 1400 hours and the lamp hour counter must be reset every time the lamp module is changed. Contact DTS to order a new lamp module. See “Replacement Parts List” in this section.

**Tool Required:** 1/4 inch (0.5 cm) flat blade screwdriver

1. Turn off the projector and unplug the power cord.
2. Wait 30 minutes to allow the projector to cool thoroughly.
3. Push the ridge on the lamp door toward the back (see figure below). The arrow on the lamp door should point to the unlock icon on the bottom of the projector. Lift the door up.

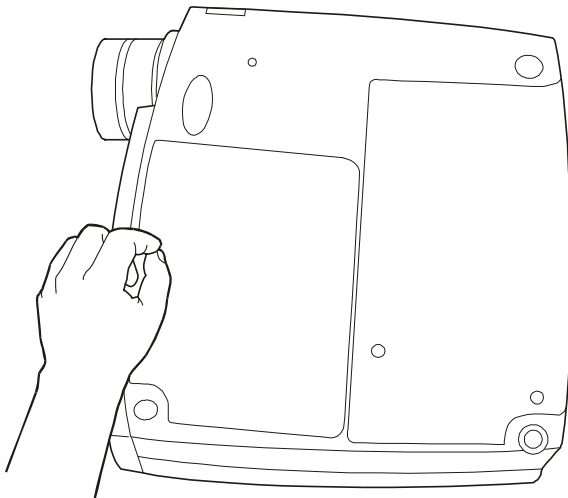

**⚠ Caution:** Never operate the projector when the lamp door is open or removed. This disrupts the airflow and will cause the projector to overheat.

- Loosen the two captive screws on the outside of the module, as shown in the figure below.

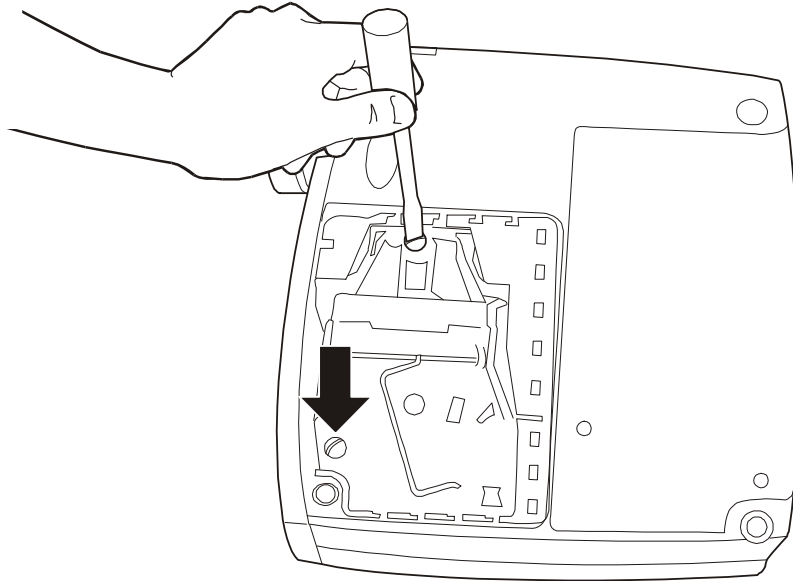

- Lift and grasp the metal bail wire and lift the module out, as shown in the figure below.

**⚠ Warning:** To avoid injury, be extremely careful when removing the lamp module. In the unlikely event that the bulb ruptures, small glass fragments may be present. The lamp module is designed to contain these fragments, but use caution when removing the lamp module.

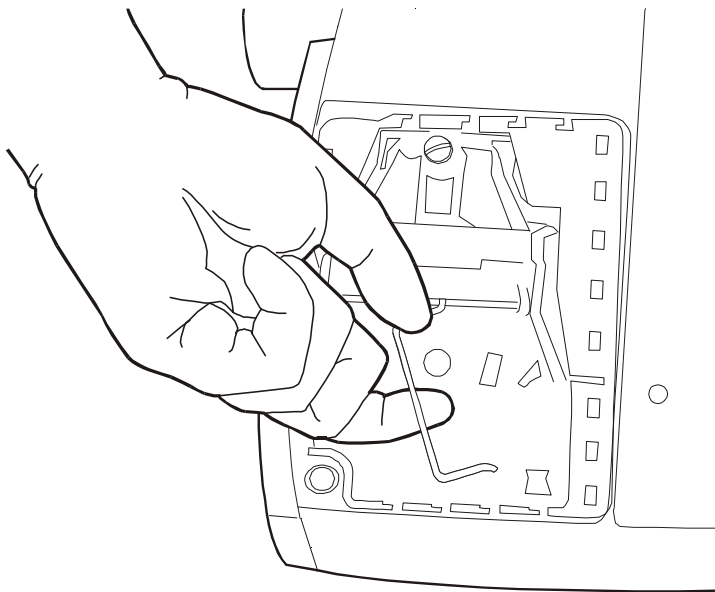

Dispose of the lamp module in an environmentally proper manner.

- Install the new lamp module, being sure to align the connector properly.

**⚠ Warning:** To avoid injury, do not drop the lamp module or touch the glass bulb! The glass may shatter.

- Push the module in until it is flush with the bottom case of the projector.
- Tighten the screws on the outside of the module.

9. Replace the lamp door by inserting the hooks on the lamp door into the slots on the projector and pressing the lamp door into place. The arrow on the lamp door should point to the lock icon on the bottom of the projector. If the lamp door does not fit properly or bulges out, remove the door and re-seat the lamp module.
10. Plug in the power cord and press the green POWER button to turn on the projector.

### G.7.1. Reset the Lamp Hour Counter on the Projector

1. On the projector keypad, press and hold the MENU button until the LED flashes.

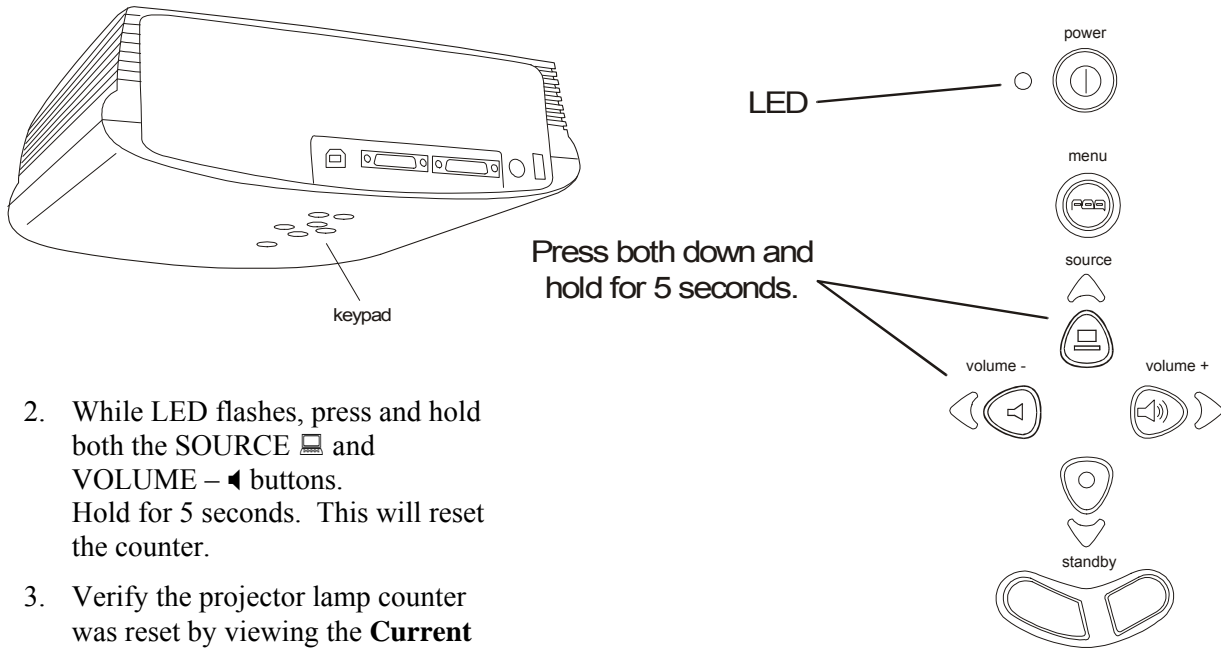

2. While LED flashes, press and hold both the SOURCE and VOLUME - buttons. Hold for 5 seconds. This will reset the counter.
3. Verify the projector lamp counter was reset by viewing the **Current Lamp Hours** display in the XD10 CSP Lamp Status menu.



## G.8. DTS-EMA Maintenance

The DTS-EMA comes with a special light shutter that requires periodic cleaning. Wipe it clean of dust and dirt using non-abrasive camera lens cleaner on a soft, dry cloth.

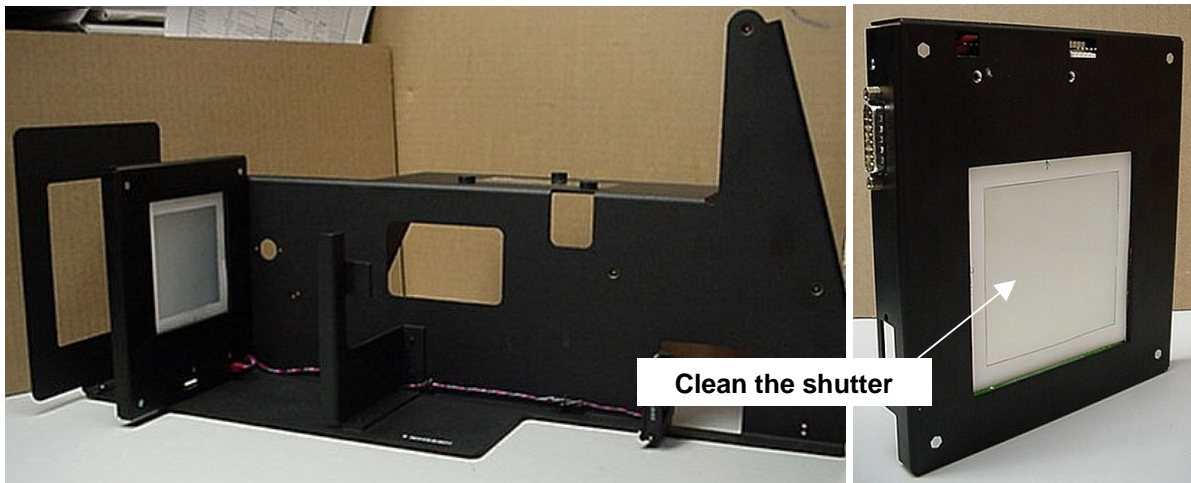

DTS EMA

## G.9. Troubleshooting the DTS-CSS Option

### No subtitles

**Note:** The Subtitle Projector option requires a separate license from DTS. The subtitles show must be downloaded into the XD10 and enabled, the projector must be connected to the Projector Video connector, and the EMA must be connected to the EMA Control connector on the rear of the XD10.

1. Verify the **CSP Text** indicator (green LED) on the XD10 is lighted.  
YES – then go to step 5.  
NO – then go to step 2.
2. In the XD10 Playscreen Display, note the title of the currently playing film soundtrack. Is this the correct film?  
YES – then go to step 3.  
NO – then load the correct file.
3. In the XD10 Playscreen Display, note the running timecode for the currently playing film. Is the timecode incrementing?  
YES – then go to step 4.  
NO – then check there is timecode on the film. Check that TCR head LED is lighted.
4. In the XD10 Playscreen Display, use the ▲ or ▼ buttons to display **CSP LANG** on the fourth line of the window. This shows the language that the subtitling projector is currently using. Is the language correct?  
YES – then go to step 5.  
NO – then select the correct language.
5. Verify the subtitle projector is powered on.  
YES – then check that the lamp is brightly lighted, the go to step 6.  
NO – then power ON and press green button.
6. Verify cabling is securely connecting the XD10 to the DTS-EMA and DTS-CSP. Check both cables for broken wires.  
YES – then go to step 9.  
NO – then fix or replace the cables.
7. Go into the CSP Lamp Status menu (on the XD10) and verify the number of lamp hours has not exceeded 1400. **The projector lamp must be replaced after 1400 hours of use.**  
YES – then go to step 8.  
NO – then replace the lamp.
8. Is the CSP LAMP FAULT indicator blinking on the XD10? If yes, the projector lamp is burned out and must be replaced.  
YES – then replace the lamp.  
NO – then go to step 9.
9. Verify the DTS-EMA fan is rotating. The fan cools the subtitling projector, and if the projector overheats, it will turn itself off. Is the fan rotating?

YES – then go to step 10.

NO – then replace the fan.

10. During intermission, enable the test “Buzz And Bill” and watch for subtitles. Verify that the subtitles are synchronized with the projected film. While test is playing, verify the function of the DTS-EMA douser. It should open when it gets the command to open - which is when subtitles are playing. Is the douser working properly?

YES – this is the end of this troubleshooting procedure.

NO – then call DTS Customer Support.

### Subtitle text is distorted on-screen

1. Clean the lens on the subtitle projector.
2. If the image is fuzzy, recheck/adjust the projector focus adjustment.
3. Verify the PROJECTOR VIDEO cable is type SVGA 15-pin HD shielded with ferrite beads on each end.

 **Caution:** Do NOT make your own video cable. The cable requires special shielding and ferrite protection.

### Subtitle text is dim on-screen

1. Verify the DTS-EMA fan is rotating. If fan stops, the projector light will dim. If fan stops rotating, replace it.
  - Note:** The projector light intensity is always set to “high” unless the EMA fan stops running, in which case the projector automatically switches to “low”.
2. Access the XD10 menu CSP LAMP STATUS and verify the number of lamp hours has not exceeded 1400.
  - Note:** The DTS-CSP lamp must be replaced after 1400 hours of use.

### Subtitle text is not the correct size on-screen

Access the XD10 menu CSP SETUP, Image Size and select the appropriate image size. A higher number will make the subtitles bigger and a smaller number will make them smaller.

### Wrong subtitles are playing

Access the XD10 menu PLAYBACK | CSP LANGUAGE and verify the show language is available and selected for play.

**Note:** The XD10 will always play the last language version loaded, unless another one is selected from this menu.

### The CSP LAMP FAULT indicator LED is blinking or is continually lighted

Access the XD10 menu CSP LAMP STATUS and verify the number of lamp hours has not exceeded 1400.

**Note:** The DTS-CSP lamp must be replaced after 1400 hours of use.

### I've just replaced the projector lamp but it will not light

1. Go into the **Current Lamp Hours** display in the XD10 **CSP Lamp Status** menu and verify that the lamp counter has been reset to “0”. If not at zero, see the topic *Reset the Lamp Hour Counter* on page A-G-20 to reset the counter.
2. Verify the projector is powered on.

3. Verify cabling is securely connecting the XD10 to the DTS-EMA and DTS-CSP. Check all 3 cables for broken wires.
4. Verify the DTS-EMA fan is turning. The fan cools the projector. If the fan is not rotating, replace it. (See Appendix A, Replacement Parts listing.)

### **Light is leaking out around the subtitles on-screen**

Reset the position of the magnetic trims on the DTS-EMA mask assembly. Use the test patterns in the XD10 menu SETUP | CSP SETUP | Test Patterns.

### **Light is seen in subtitle area when no subtitles are supposed to play**

1. The DTS-EMA douser is probably open. Be sure “Douser/Fan Control” cable is plugged in and DTS-EMA fan is turning. Check cable for broken wires
2. Verify the XD10 menu SETUP | CSP SETUP | Test Patterns menu has been correctly exited. All test patterns should be turned off.
3. Power off the subtitle projector until there is time to troubleshoot the problem. The DTS-EMA solenoid could be bad.

### **Subtitles are cut off on the screen**

1. Verify the physical positioning of the subtitle projector.
2. Verify the positioning of the DTS-EMA magnetic trims. Use the test patterns in XD10 menu SETUP | CSP SETUP | Test Patterns.

## **G.10. Troubleshooting Rear Window (Captions) Option**

### **No Rear Window captions**

1. In XD10, verify the captions show is loaded on the hard drive and is enabled.
  - Note:** The Rear Window option requires a separate license from DTS. The show must be downloaded into the XD10 and enabled, and the Rear Window captions equipment must be connected to COM1 connector on the rear of the XD10.
2. Verify the captioning equipment is powered on.
3. Verify the XD10 TIMECODE indicator is illuminated.
4. Verify the XD10 SERIAL indicator is illuminated.
5. Verify COM 1 cable is securely connecting the XD10 to the caption system. Check cable for broken wires.
6. Refer to the caption playback equipment manufacturer for test procedure and troubleshooting guidelines.

## **G.11. Troubleshooting Narration Option**

### **No narration audio**

1. Verify the narration transmitter is powered on.
2. Verify the narration headsets are connected and their volume is turned up.
3. In XD10, verify the Narration show is loaded on the hard drive and is enabled.
  - Note:** The Narration option requires a separate license from DTS. The show must be downloaded into the XD10 and enabled, and the Narration audio output connector on the rear of the XD10 must be connected to the narration transmission equipment.

4. Verify the XD10 TIMECODE indicator is lighted.
5. Verify the XD10 NARRATION indicator is lighted.
6. Enable DTS-CSS self-play test “1K @ -20dB FS”. Verify 300mV RMS ( $\pm 10\text{mv}$ ) output at NARR OUT.  
If no output, replace the E622 board. If there is output, refer to the transmitter manufacturer for test procedure.

### Narration sounds too loud/soft

**Note:** Volume controls are usually on each individual headset.

Enable XD10 self-play test “1K @ -20dB FS”. Verify 300mV RMS ( $\pm 10\text{mv}$ ) output at NARR OUT. If no output, replace the E622 board. If there is output, refer to the transmitter manufacturer for test procedure.

### Narration sounds distorted

1. Enable XD10 self-play test “1K @ -20dB FS”. Verify 300mV RMS ( $\pm 10\text{mv}$ ) output at NARR OUT.
2. Enable the XD10 self-play test “Buzz And Bill” and listen with the narration headsets.
3. Try replacing the internal E622 board.
4. Refer to the transmitter manufacturer for test procedure.

### Noise in narration track

1. Verify the NARR OUT cables are not routed next to power lines, film projector motors, or fluorescent lights.
2. If getting RF interference, contact DTS for ferrite bead suppressors that attach to the audio output cables.

### The narration is NOT playing in sync with the sound track or action on-screen

Go to the XD10's Setup | Timecode Reader menu to verify the offset value has been correctly set. If necessary, see *Timecode Reader Sync Adjustment* (chapter 3).

### Forgot Password

Contact DTS.

## G.12. Testing Subtitles

1. Play the test film “Bill and Buzz”.
2. Verify the subtitles are synchronized with the film. If NOT, the most likely problem is the timecode reader offset is incorrect. (If adjustment is needed, see *TC Reader Offset*, in chapter 1, for details.)
3. Verify the subtitles are positioned correctly on the screen. (If adjustment is needed, see *CSP Setup* in chapter 1.)

## G.13. Testing Narration

### Equipment needed: Voltmeter

1. Disconnect the XD10 Narration cable from the rear of the XD10.

2. Run the audio test “Alignment Tones”. This is accessible from the System Setup | Audio Setup | Audio Tests Menu. The XD10 should output a 1kHz reference tone on the narration output.
3. Use a voltmeter to verify 300 mV RMS  $\pm$  10 mV at the NARR connector on the rear of the XD10.
4. Reconnect the NARR connector on the rear of the XD10.
5. Play the test film “Bill and Buzz”.
6. The test narrative should be heard clearly in the narration headsets. Verify the narration is synchronized with the projected image. If NOT, the most likely problem is the timecode reader offset is incorrect. (If adjustment is needed, see *TC Reader Offset*, in chapter 1, for details.)

## G.14. Testing Rear Window Captions

1. Verify COM 1 cable is securely connecting the XD10 to the caption system.
2. Play the test film “Bill and Buzz”. The test captions should appear on the scrolling display at the rear of the theater.
3. Using the Plexiglas viewer, sit in the theater and verify the captions are clear and easy to read. Verify the captions are synchronized with the projected image. If NOT, the most likely problem is the timecode reader offset is incorrect. (If adjustment is needed, see *TC Reader Offset*, in chapter 1, for details.)



## Appendix H. Technical Notes

This appendix contains DTS Technical Notes related to the XD10 and its options. The table below lists the TNs, which follow this page in the order they are listed.

| <b>Tech Note Designator</b> | <b>Title</b>                                      |
|-----------------------------|---|
| TN-E538                     | Maintenance to Prevent Premature CSP Lamp Failure |
| TN-E550                     | Reader Head LED Voltage Calibration               |





|   |                                     |                          |                             |     |                |
|---|-------------------------------------|--------------------------|-----------------------------|-----|----------------|
|  | TITLE                               |                          | NUMBER                      | REV | Page 1<br>of 3 |
|   | Reader Head LED Voltage Calibration |                          | TN-E550                     | A   |                |
| DATE PREPARED<br>August 6, 2002   | CREATED BY:<br>K. Hultgren          | EFFECTIVE DATE<br>8/7/02 | APPROVED BY:<br>B. Plunkett |     |                |

DTS, 5171 Clareton Dr., Agoura Hills, CA 91301

Contact Document Control for the latest revision.

All reader heads must be periodically checked for proper gain. It is easily done using a multimeter and with **NO** film loaded through the reader. For demonstration purposes, the reader is shown removed from the projector.

### TOOLS REQUIRED

- DTS player
- Timecode cable
- 1/16" (1.58 mm) Allen-head (hex) screwdriver
- Small flat-bladed screwdriver
- Multimeter

① Remove the reader's back cover by removing the -4- hex screws. Save the screws.

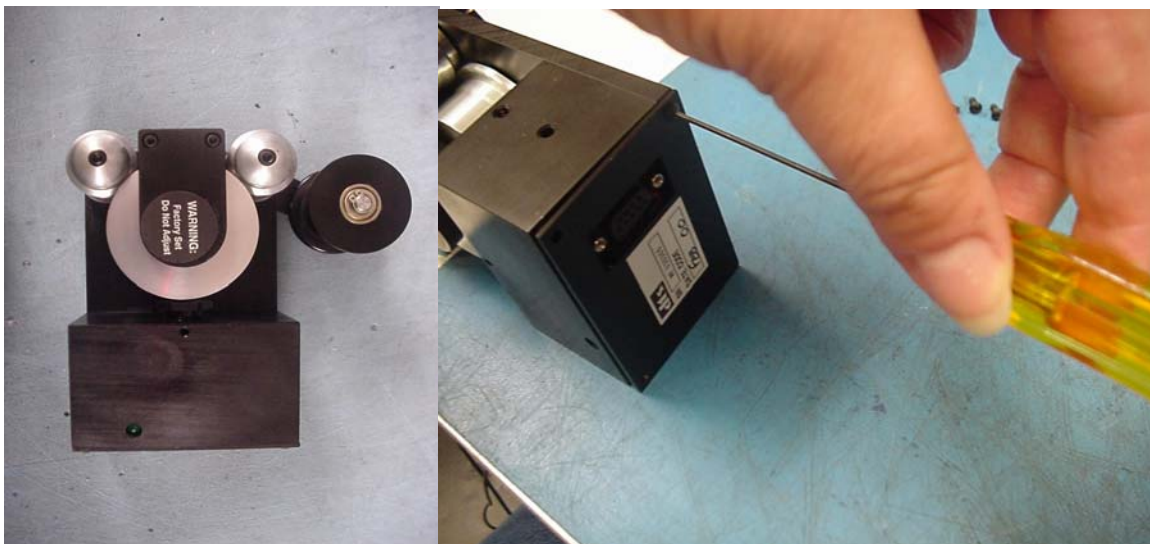

② First, set the meter to DC volts. Connect leads to TP1 ("+" signal) and TP2 (ground) on the D424 board. Then, connect the reader to a powered DTS player. The reader gets its power from the DTS player.

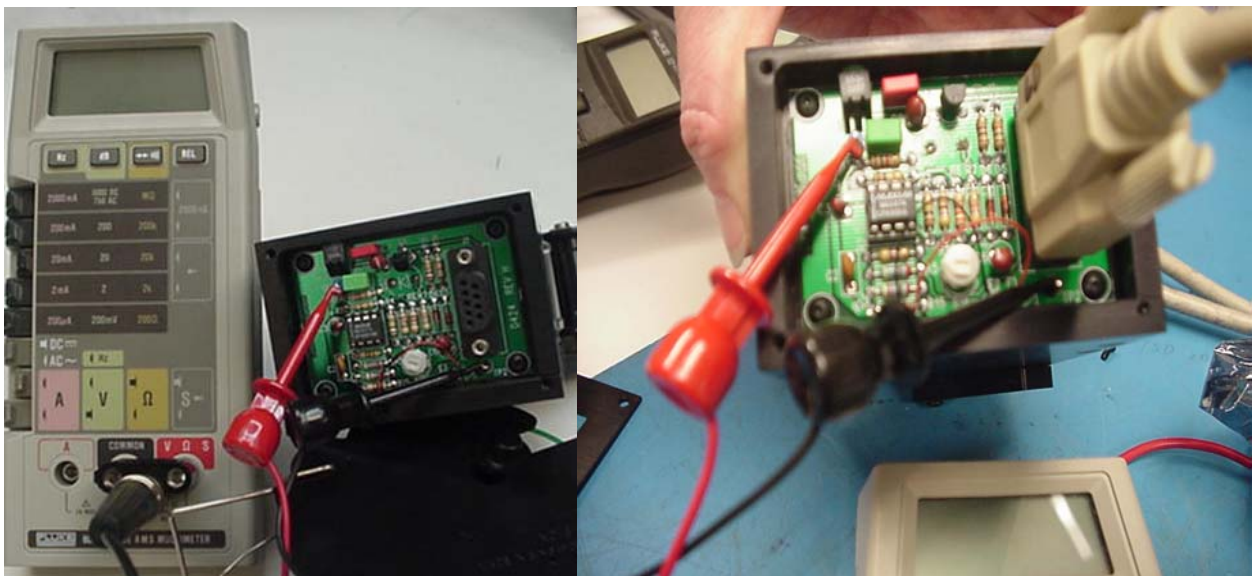

- ③ Adjust R16 trim pot (on Rev. E and higher D424 boards) for 4 volts DC on the multimeter. If you cannot achieve the correct voltage, the LED may be damaged or aged. Older version D424 boards may not have a trim pot. In that case, if the voltage is not between 3.5 and 4.5 volts DC, then you must do a repair-exchange on the reader. Contact your local DTS dealer.

Adjust trim pot until the volt meter reads 4 volts DC

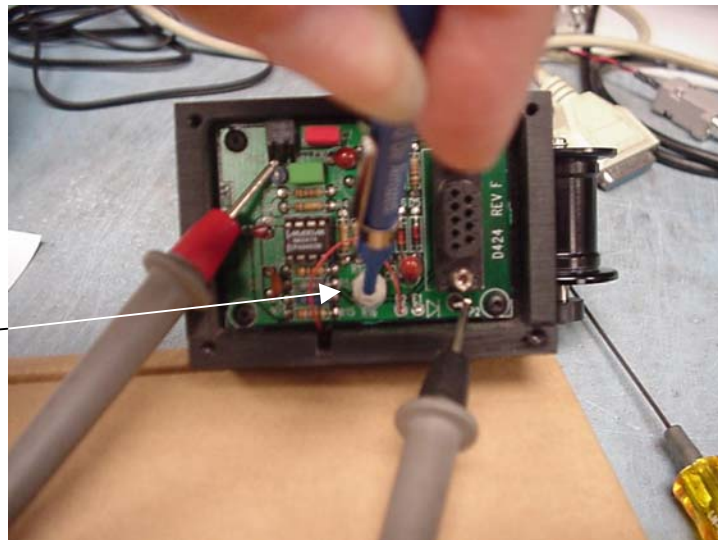

- ④ On older versions of D424 boards that have a trim pot but no test points, carefully connect your meter as shown below and measure the voltage. Adjust trim pot for 4 volts DC on a multimeter.

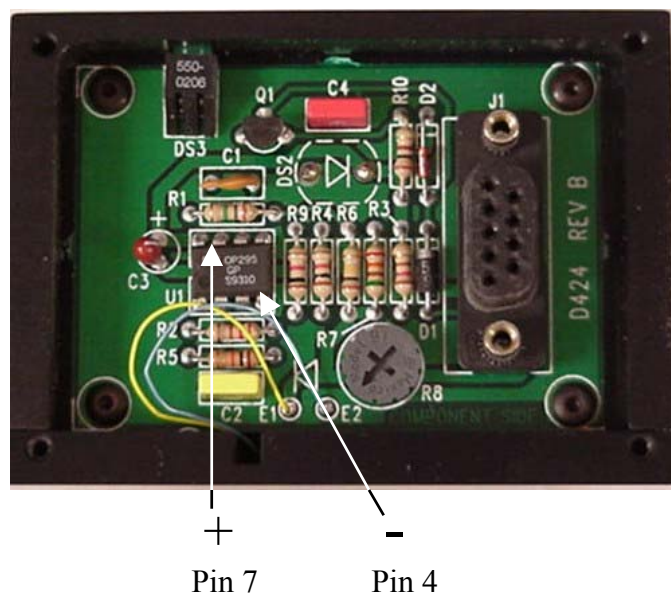

Version “A” D424 boards do not have test points or a trim pot. In that case, measure the same as above and if the voltage is not between 3.5 and 4.5 volts DC, then you must do a repair-exchange on the reader. Contact your local DTS dealer.

|   |   |                            |                          |                             |                |
|---|---|----------------------------|--------------------------|-----------------------------|----------------|
|  | TITLE<br><b>Reader Head LED Voltage Calibration</b> |                            | NUMBER<br><b>TN-E550</b> | REV<br><b>A</b>             | Page 3<br>of 3 |
|   | DATE PREPARED<br>August 6, 2002                     | CREATED BY:<br>K. Hultgren | EFFECTIVE DATE<br>8/7/02 | APPROVED BY:<br>B. Plunkett |                |

DTS, 5171 Clareton Dr., Agoura Hills, CA 91301 Contact Document Control for the latest revision.

- ⑤ After adjustments are complete, reattach the back cover using the saved hex screws. Tighten all set-screws on the reader and check that all rollers rotate freely and do not wobble. Check that the reader's mounting bracket is tightly fastened to the projector and that the reader is securely attached to the bracket.



One set-screw to secure auxiliary roller

Two set-screws to secure rollers

Please refer questions to DTS Cinema Technical Support

*Telephone:* (818) 706-3525 or (800) 959-4109

*Fax:* (818) 879-27246

*Email:* [cinematech@dtsonline.com](mailto:cinematech@dtsonline.com)

[www.dtsonline.com](http://www.dtsonline.com)

|   |  |                            |                             |                             |                |
|---|--|----------------------------|-----------------------------|-----------------------------|----------------|
|  | TITLE<br><b>Cleaning the CSP Lamp Module Dust Filter</b> |                            | NUMBER<br><b>E538</b>       | REV<br><b>0</b>             | Page<br>1 of 3 |
|   | DATE PREPARED<br>7/02/2002                               | CREATED BY:<br>K. Hultgren | EFFECTIVE DATE<br>7/02/2002 | APPROVED BY:<br>B. Plunkett |                |

DTS, 5171 Clareton Dr., Agoura Hills, CA 91301 Contact Document Control for the latest revision

## Maintenance to Prevent Premature DTS-CSP Lamp Failure

In dirty or dusty environments, the lamp module dust filter screen in the DTS-CSP projector can become plugged, causing excessively high temperatures inside the lamp module. Excessively high temperatures can cause premature lamp failure. Routine maintenance to remove dust and dirt from the filter screens lowers the lamp operating temperature and lengthens lamp life. As depicted below, clean the lamp module dust filter screen every **200-250 hours** when the projector is used in areas with high levels of airborne contaminants like lint, dust or smoke.

### Procedure for cleaning the lamp module dust filter screen

1. First, be sure the projector is cool. Then, remove the lamp door and lamp module.

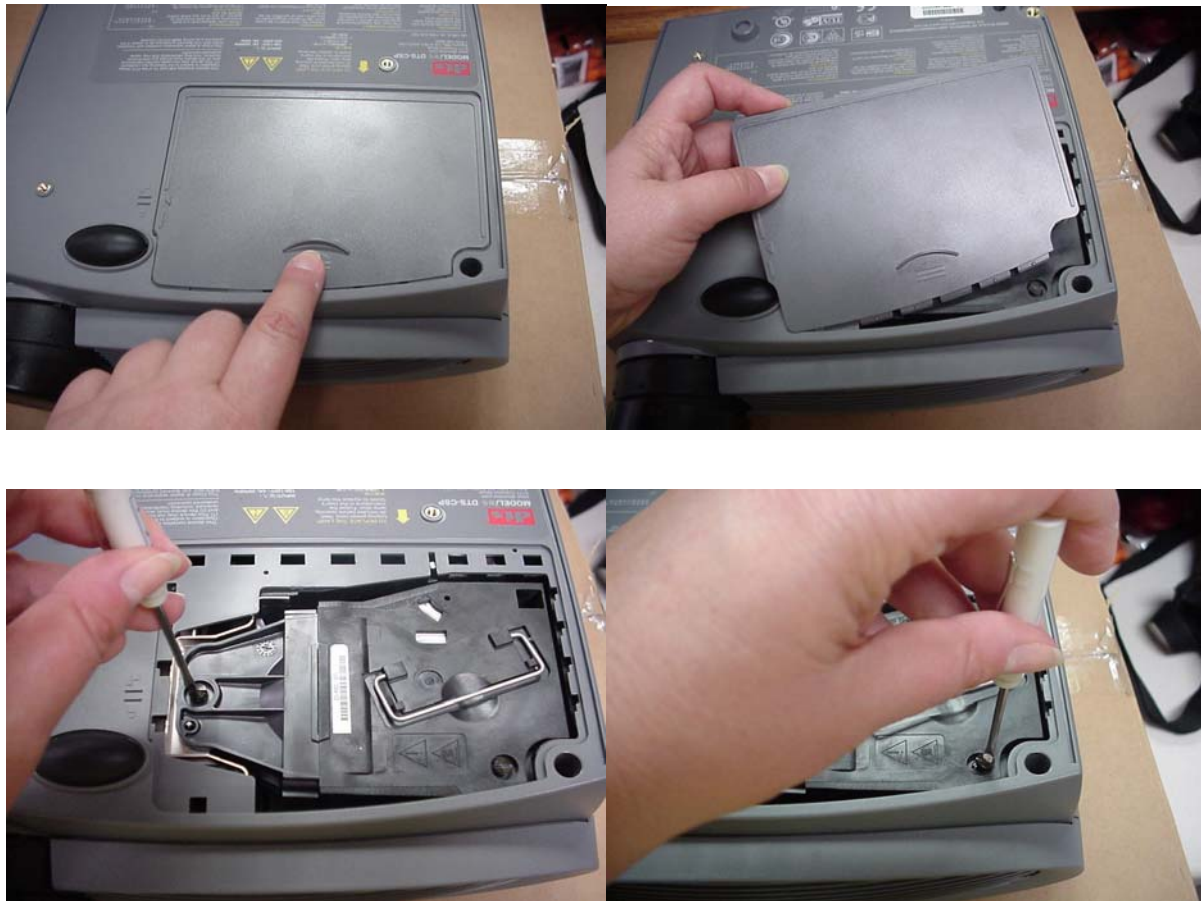



2. After removing the lamp module, examine the condition of the dust filter screen. The screen is in the front part of the lamp module. Dirt and dust accumulation on the screen must be removed.

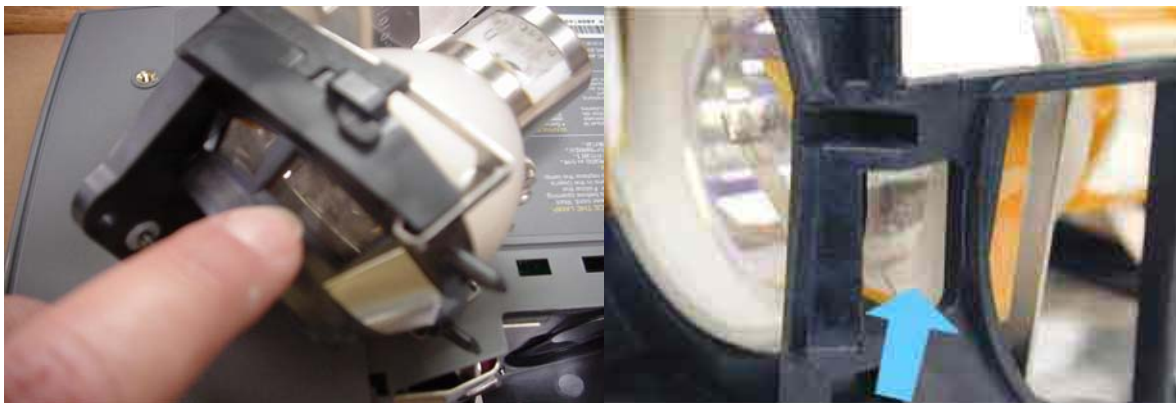

3. Use a cotton swab dipped in isopropyl alcohol to lightly wipe the screen. After you've wiped the screen, use canned air to blow away remaining contaminants.





TITLE  
**Cleaning the CSP Lamp Module Dust Filter**

NUMBER  
**E538**

REV  
**0**

Page  
3 of 3

DATE PREPARED  
7/02/2002

CREATED BY:  
K. Hultgren

EFFECTIVE DATE  
7/02/2002

APPROVED BY:  
B. Plunkett

DTS, 5171 Clareton Dr., Agoura Hills, CA 91301

Contact Document Control for the latest revision

4. Before replacing the cleaned lamp module, use canned air to clean out the projector lamp house cavity. Then, replace the lamp and lamp door.





### DTS MARQUEE SIGN ORDER FORM

For every DTS unit installed in a theater, we will provide one-sheet posters, 4-inch mini-marquee, 8-, 10-, or 12-inch marquee signs at no charge. Simply complete and submit the following information. Marquees and posters can be sent directly to the theater or dealer for distribution. If the marquees are directly sent to the dealer, the name(s) and location(s) of the theater(s) is needed for our records.

Materials will be shipped within 2 to 3 weeks upon receipt of this completed order form.

Dealer: \_\_\_\_\_

Theater: \_\_\_\_\_

Address: \_\_\_\_\_

Address: \_\_\_\_\_

\_\_\_\_\_

\_\_\_\_\_

Contact: \_\_\_\_\_

Contact: \_\_\_\_\_

Phone: \_\_\_\_\_

Phone: \_\_\_\_\_

### FOR DTS-EQUIPPED THEATERS

4-inch mini marquee Qty. \_\_\_\_\_

8-inch panel Qty. \_\_\_\_\_

10-inch panel Qty. \_\_\_\_\_

12-inch panel Qty. \_\_\_\_\_

One sheets Qty. \_\_\_\_\_

**Return this form to:** Customer Service  
Digital Theater Systems  
5171 Clareton Drive  
Agoura Hills, CA 91301 USA

Telephone: (818) 706-3525 or (800) 959-4109  
Fax: (818) 879-2746



# WARRANTY

Equipment manufactured by Digital Theater Systems, Inc. is warranted against defects in materials and workmanship for one year from the date of purchase. There are no other express or implied warranties. Digital Theater Systems, Inc.'s obligation is restricted to repair and replacement of defective parts. Under no circumstances will Digital Theater Systems, Inc. be liable for any other damage, either direct or consequential.

### NOTE

**Warranty void unless the following Factory Warranty Information is provided to DTS within thirty (30) days of purchase.**

#### FACTORY WARRANTY INFORMATION

Complete this form for **each** DTS XD10 installation

THEATER NAME/CIRCUIT: \_\_\_\_\_

THEATER LOCATION: \_\_\_\_\_

SCREEN NUMBER \_\_\_\_\_

THEATER CONTACT: Name: \_\_\_\_\_

Telephone: \_\_\_\_\_

LOCAL TECH: Name: \_\_\_\_\_

Telephone: \_\_\_\_\_

DTS XD10 SERIAL #: \_\_\_\_\_

Date of Purchase \_\_\_\_\_

TIMECODE READER: \_\_\_\_\_

PROJECTOR TYPE: \_\_\_\_\_

SOUND PROCESSOR: \_\_\_\_\_

SOUND AMPLIFIER: \_\_\_\_\_

SPEAKER SYSTEM: \_\_\_\_\_

Screen (model): \_\_\_\_\_

Surrounds (model): \_\_\_\_\_

Split: \_\_\_\_\_ Mono: \_\_\_\_\_

Subwoofer: \_\_\_\_\_

Self-powered? Yes  No

Subwoofer Amp (model): \_\_\_\_\_

Are the Left Extra and Right Extra being used for Subwoofer? Yes  No

**Return complete form via Fax to: +1 (818) 879-2476; Att: Customer Service, Or via mail to: DTS Customer Service – 5171 Clareton Drive – Agoura Hills, CA 91301 – USA.**