

Film-Tech

The information contained in this Adobe Acrobat pdf file is provided at your own risk and good judgment.

These manuals are designed to facilitate the exchange of information related to cinema projection and film handling, with no warranties nor obligations from the authors, for qualified field service engineers.

If you are not a qualified technician, please make no adjustments to anything you may read about in these Adobe manual downloads.

www.film-tech.com

N O R E L C O
INDEX OF THEATRE SERVICE INSTRUCTIONS
FOR THE UNIVERSAL 70/35 PROJECTOR

<u>NO.</u>	<u>TITLE</u>	<u>ISSUE</u>	<u>REMARKS</u>
1	CX 1701 Ripple Filter		*
2	35mm Operation Requirements	2	
3	Exciter Lamp Operation		
4	Changeover Dowser Operation		**
5	Fire Traps & Roller Assembly		*
6	Projector Lubrication	2	
7	Runner Plates	2	
8	Master Motors		
9	Roller Adjustments		
10	Fire Traps		
11	Magnetic Cluster Connections		
12	Cat. No. 3055 Optical Sound Head		
13	Inspection of Projector Driving Mechanism		
14	C1 704 24 Pressure Band Holder		
15	Film Gates		
16	C1 902 11 Dowser Arm Assembly		***
17	C1 750 48 Main Drive Gear		***
18	Aperture Plates		
19	Take-Up Drives on 70/35 Projectors Model AII		***
20	Magnetic Clusters *Applies to Models with Upper Base Serial Nos. in 59--- and 63--- (AII) Series. **Applies in general to Models with Upper Base Serial Nos. in the 1000 Series (A.O.Co.)		

***Model AII Projectors - Serial Nos. 1800 and up have New Assembly.

N O R E L C O

THEATRE SERVICE INSTRUCTION #1

CX-1701 RIPPLE FILTERS

These filters, mounted in a perforated metal box, for smoothing the D.C. supply to the changeover coil, have in some instances been shipped as loose parts for installation at the theatre.

In these instances the following checks should be made for correct operation after the filter has been connected into the circuit.

- (1) With machine idle the voltage at 51-52 (the two right hand terminals of lower terminal strip in base) should measure 150 to 160 volts D.C.
- (2) With machine running and changeover dower open the voltage at 51-52 should measure 75 to 80 volts D.C.

If the reading obtained by (1) above is substantially less than 150 volts, i.e. approximately 80 to 85 volts, the filter should be examined and the negative (-) lead from the condenser disconnected from the resistor R2 and reconnected to the adjacent tie-point terminal.

If the reading in (2) above is not obtained, the sliders on the resistors should be shifted.

11-25-60
North American Philips Company, Inc.
Motion Picture Equipment Division
100 East 42nd Street
New York 17, N. Y.

N O R E L C O

THEATRE SERVICE INSTRUCTION #2

35 MM OPERATION REQUIREMENTS

When preparing to convert from 70 MM to 35 MM operation the availability of the following items should be considered.

- (A) Lenses for "flat" presentations.
- (B) Lenses for CinemaScope presentations.
- (C) Lens adapters for fitting lenses having a 2 25/32" O.D. into the 4" I.D. of the NORELCO eccentric adapters. These adapters are the Simplex Cat. No. G 2156 or equivalent.
- (D) 35 MM film splicer.
- (E) 35 MM hand rewind.
- (F) 35 MM reels with 1/2" bore, 5" minimum hub diameter and 70 MM "spacers". (Such as manufactured by Goldberg.)
- (G) Cat.No. C1-704-71 Blank aperture plates.
- (H) Cat. No. 3141 Lens Adapter (C1-705-05).

Items (A) to (F) inclusive, should be obtained from a theatre supply dealer if not already on hand.

Items (G) and (H) can be ordered from -

North American Philips Company

- or -

Your NORELCO Theatre Supply Dealer

11-25-60

North American Philips Company, Inc.
Motion Picture Equipment Division
100 East 42nd Street
New York 17, N. Y.

N O R E L C O

THEATRE SERVICE INSTRUCTION #3

EXCITER LAMP OPERATION

If the amplifier gain available requires that the 4 ampere exciter lamps be operated at full current there is a possibility of excessive heating of the film leader when the projector is not running.

Where this is the case, the use of the circuit shown on the attached drawing is recommended. It provides a low pre-heat voltage at the lamp and instantly provides full current when the motor is started.

Of course if the exciter power supply is the type which employs a pre-heat circuit this instruction can be ignored.

11-25-60

North American Philips Company, Inc.
Motion Picture Equipment Division
100 East 42nd Street
New York 17, N. Y.

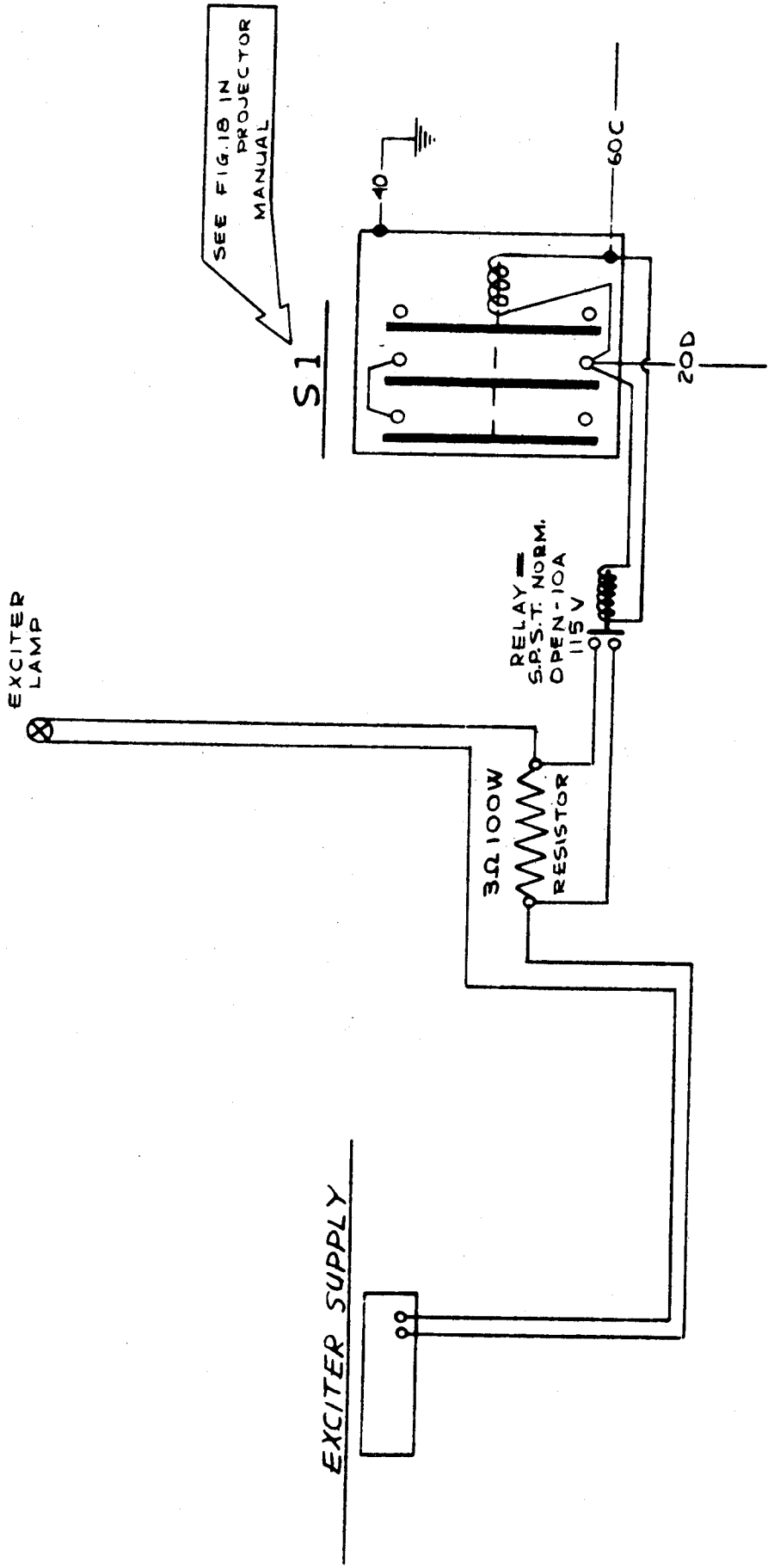

SUGGESTED PRE-HEAT WIRING

SEE THEATER SERVICE INSTRUCTION # 3

11-28-60
F.J.P.
751 #1

NORTH AMERICAN PHILIPS CO., INC.
NEW YORK, N.Y.

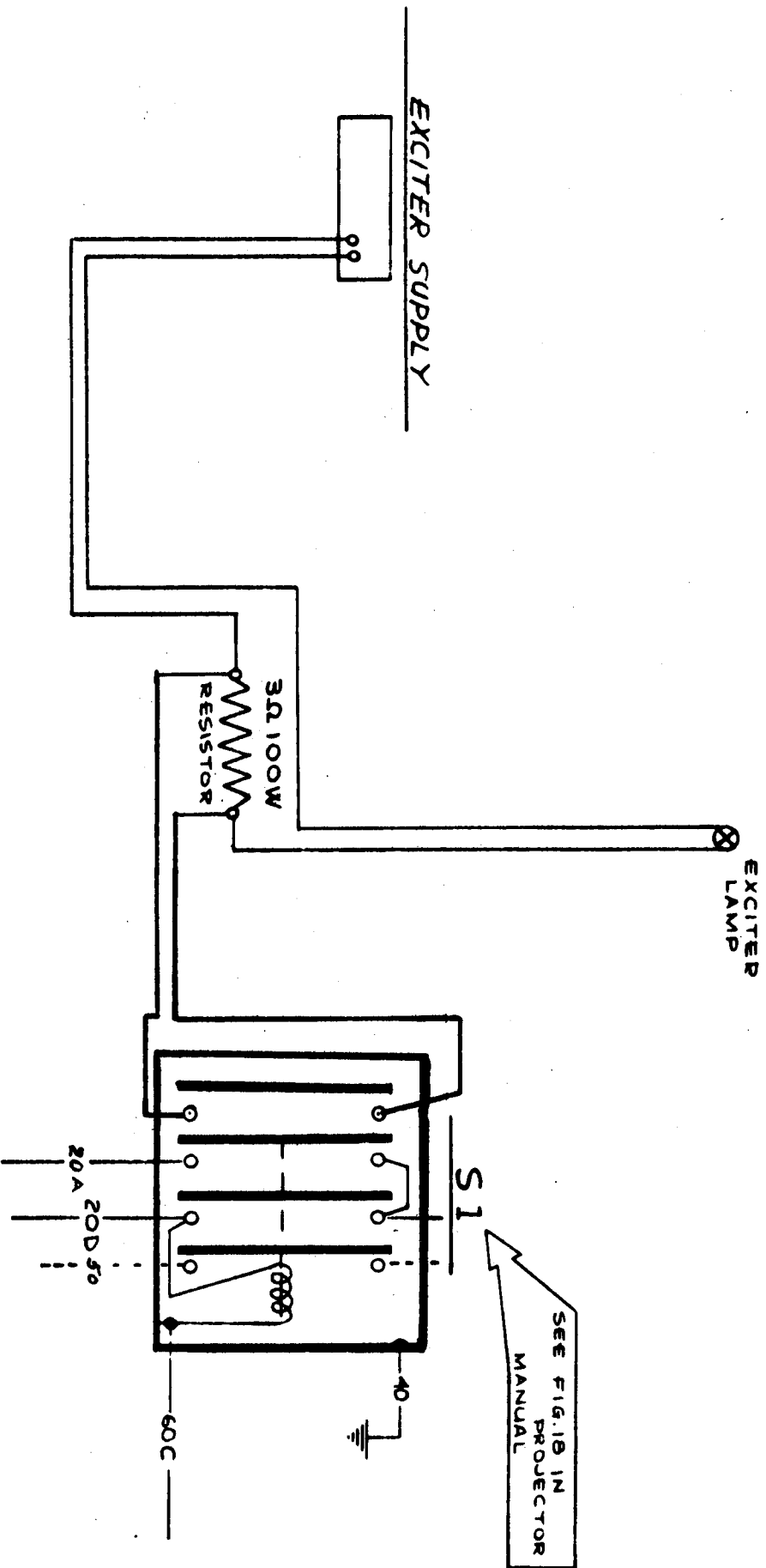

SUGGESTED PRE-HEAT WIRING
SEE THEATER SERVICE INSTRUCTION # 3

4-28-64
 FJP

North American Phillips Company, Inc.
 New York, N.Y.

N O R E L C O

THEATRE SERVICE INSTRUCTION #4

CHANGE OVER DOWSER OPERATION

Experience indicates that improved operation and solenoid life can be obtained by the use of a ripple filter in the output of the rectifier, R1 - Fig. 18 - Page 19 - Instruction Book No. P1955.

A suitable filter circuit is shown on the attached drawing. Parts should be obtained from a local radio or electronic supply house, if a filter has not been installed previously.

Theory of Operation:

During no load conditions the condenser charges to a peak voltage of 150 to 160 V. D. C. When the dowser switches are closed the coil is momentarily energized by this high voltage. The resistors in the filter are then adjusted to provide approximately 80 Volts to the coil as a holding voltage. This is below the rated voltage of the solenoid but is adequate for holding the armature up, but at a reduced current and temperature. In addition the lower holding voltage and smoother current results in a faster collapse of the magnetic field and a more rapid dowser closing when the circuit is opened.

The factory has also made available an improved C1-902-09 solenoid which can be identified by the colored plastic leads used instead of the asbestos covered wires.

A C1-708-90 heat shield will soon become available to replace the C1-704-15 strip. This shield provides protection for the solenoid and the plastic terminal strip. The shields will carry a list price of \$11.40 each.

12-8-60
North American Philips Company, Inc.
Motion Picture Equipment Division
100 East 42nd Street
New York 17, N. Y.

N O R E L C O

THEATRE SERVICE INSTRUCTION #5

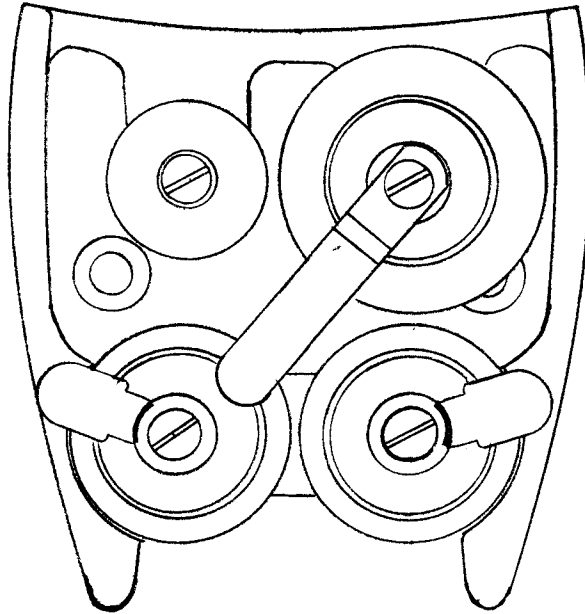

VIEW OF CORRECT ASSEMBLY OF ROLLERS AND GUARDS IN
UNIVERSAL (4 SHAFT) FIRE TRAP, FOR UPPER MAGAZINE, WHEN
STANDARD U.S. REWIND PRACTICE IS FOLLOWED.

FOR LOWER MAGAZINE VIEW TURN PAGE UPSIDE DOWN.

Note - Flanged roller is moved to upper left shaft
for standard European Rewind Practice.

N O R E L C O

THEATRE SERVICE INSTRUCTION #6

NORELCO PROJECTOR LUBRICATION

Lubrication procedures are given in the Cat. No. 3070 Operating Instructions on Page 23, Para. 25; and Page 34, Para. 35.

The purpose of this Instruction is to expand on the above data so that maximum life and trouble-free service may be obtained from the NORELCO projector. The original instructions on the pages noted above still apply and should be referred to.

PROJECTOR OIL RESERVOIR

For new installations, and each time a major component has been replaced, change the oil after the first 20 hours of operation, then after 50 hours, then after 100 hours, and finally every 250 hours. The kind of oil depends on the ambient temperature in the booth. The tolerances of the intermittent mechanism have been calculated for a definite oil film and any oil other than that specified may cause serious troubles.

Temp. F.	Oil Grade	Equivalent	Remarks
40° & Lower	Light	Shell Turbo #27	These oils are most economically obtained locally. Gasoline service stations generally do not stock. Contact local sales office of companies noted and arrange for 5 gal. purchase.
40° to 80°	Medium	Shell Turbo #29 Caltex Regal C	
80° and Up	Heavy	Shell Turbo #33 Caltex Regal E	

LUBRICATION OF VARIOUS PARTS

WEEKLY (for maximum of 20 hours operation per projector)

Esso - Handy Oil

Edge Guide Roller Bearings.

Outboard Bearing on Intermittent (red hole).

Pad Rollers.

Remove rollers and rub spindles lightly with oil.

Guide & Idler Rollers (not equipped with ball bearings).

Remove rollers, clean bearings and shafts; apply 1 drop of oil and spread with finger.

Note: Black nylon rollers require no lubrication.

Continued -

N O R E L C OTHEATRE SERVICE INSTRUCTION #6MONTHLYEsso - Handy Oil

Pivot Points of film pile-up linkage.

Projector Oil

Pad Roller Assemblies.

Introduce a drop of oil into the rear (hollow) end of shaft, at locking pin slot and at bracket bearings. Unit can be dismantled for cleaning and oiling by removing locking screw, hex nut, spring and spacing collar. If this is done, re-assembly must include proper setting of spacing collar and adjustment of pad roller pressure.
(Do not interchange pad roller assemblies.)

Spindles for the pressure roller arms on the magnetic and optical sound heads.

Remove screw, hex nut, spring and arm. Apply 1 drop of projector oil and spread. Readjust spring tension for correct pressure.

Molykote Powder

Armature shaft of dowser solenoid.

Shell Macoma #78 or Caltex Thuban Compound.

Ball bearings in the nylon pressure roller in magnetic sound head, and in the steel pressure roller in the optical sound head.
Remove roller and lubricate bearings as required.

EVERY 3 MONTHSShell Macoma #78 or Caltex Thuban Compound

Felt Discs on Upper & Lower Magazine Friction Clutches.
Saturate - squeeze out excess.
Note: Under certain conditions more frequent lubrication might be desirable.

Sliding Surfaces of Lens Holder
Clean and grease slightly.

Shell R-175 Ball Bearing Grease

Extension Shaft for Driving Lower Take-up Gears.
Remove and grease ends generously. Reassemble.

Projector & Magazine Door Hinge Pins & Catches, Reel Latches.
Coat lightly with grease.

Continued -

N O R E L C O

THEATRE SERVICE INSTRUCTION #6

EVERY 3 MONTHS (Cont'd)

Shell Barbatia 4 Graphite Grease

Pinion and Gear of Take-up Drive Assembly.
Clean teeth and coat lightly with grease.

AS REQUIRED OR AFTER MAJOR OVERHAUL

Light Spindle Oil

Optical Sound Drum Shaft Bearings.
Dismantle shaft, wash bearings in clean
solvent, and relubricate.

Projector Oil

Magnetic Sound Drum Shaft Bearings.
Dismantle, clean as above and relubricate.

Fire Trap Roller Ball Bearings
Remove and apply 2 drops of oil to
each bearing.

Shell R 175 Ball Bearing Grease

Ball Bearings on Reel Shafts in both Magazine.
Wash, dry and re-pack with grease.

12-16-60 - FJP
North American Philips Company, Inc.
Motion Picture Equipment Division
100 East 42nd Street
New York 17, N. Y.

N O R E L C O

THEATRE SERVICE INSTRUCTION #6

ADDENDUM #1

T.S. 1 #6 indicates the use of Shell Macoma #78 or Caltex Thuban Compound for use at certain points in the NORELCO 70/35 Projector.

Other suitable lubricants for those points are:

- Caltex Thuban K
- Shell Dentax 140 (a)
- Shell Valvata 79
- Esso Gear Oil 140 (Heavy) (a)
- Esso Valesso 140
- Mobil Mobilube C (a)
- Mobil Cylinder Oil Super 600W Mineral

The oils marked (a) are automotive lubricants probably obtainable at appropriate service stations.

+ + + + + + + + + +

Substitutes for Shell R-175 Ball Bearing Grease are:

- Hertner Transverter Grease (National Theatre Supply Co.)
- Shell Alvania EP Grease Z
- Keystone #88X Light Grease
- AP1056 Grease (Altec Service Co.)

+ + + + + + + + + +

Suitable in place of Shell Barbatia 4 Graphite Grease are:

- Keystone Extra Hard Graphite Grease
- Dixons Graphitoleo (Altec Service Co.)

+ + + + + + + + + +

Keystone brand lubricants are usually packaged in 1 lb. cans and widely distributed throughout the U.S. Reference is suggested to the yellow pages of the Telephone Directory, under "Oils - Lubricating", sub-heading "Keystone Lubricants".

11-14-61 - FJP
North American Philips Company, Inc.
Motion Picture Equipment Division
100 East 42nd Street
New York 17, N. Y.

N O R E L C O

THEATRE SERVICE INSTRUCTION #7

ISSUE 2

This instruction cancels the earlier issue of T.S.I. #7 dated 12-16-60 which should be destroyed.

C1-606-93 (70MM) RUNNER PLATES:

Worn runner plates can be resurfaced, as detailed below until the thickness at points "A", as shown on the drawing, is 0.450" minimum. THE WORK SHOULD ONLY BE ATTEMPTED BY A SKILLED PERSON AND USING THE PROPER TOOLS.

MATERIAL REQUIRED:

- 1 - Exactly flat grindstone, at least 3" wide and 3" to 4" long. An aluminum oxide stone is generally recommended for TANTUNG the alloy used for the runner plates. However a #107-S1C 4" diameter combination CARBORUNDUM stone has been successfully used.
- 1 - Sheet very fine emery cloth.
- 1 - Sheet crocus cloth.
- 1 - Piece mirror plate glass.
- 1 - Micrometer.
- Masking Tape.
- 1 - Wooden block - 3-1/4" x 1" x 7/8".
- 2 - #10 x 3/4" L R.H.W. screws.

PROCEDURE:

Fasten the wooden block to the back of the plate using two R.H.W. screws. Grind the runner plate on the flat grinding stone until both faces are perfectly "clean", i.e. contacted all over by the stone. Use a rotary movement and check often so as not to grind off too much material. During grinding the plate should be

rocked along its curvature to avoid making flat spots. Follow any lubrication instructions supplied with stone.

After both running surfaces are ground "clean" use a micrometer to carefully measure the 6 plates shown on the drawing below. The maximum allowable difference between the two "A" points is 0.0004". The same maximum tolerance difference applies to the four "B" points. If necessary regrind the thickest areas using increased pressure and remeasure.

Stretch a piece of emery cloth on the mirror plate and fasten with masking tape. Polish the runner plate.

Repeat using the crocus cloth. Polish in the direction of film travel and make only straight rocking movements.

Recheck thicknesses at "A" and "B" - repolish as required.

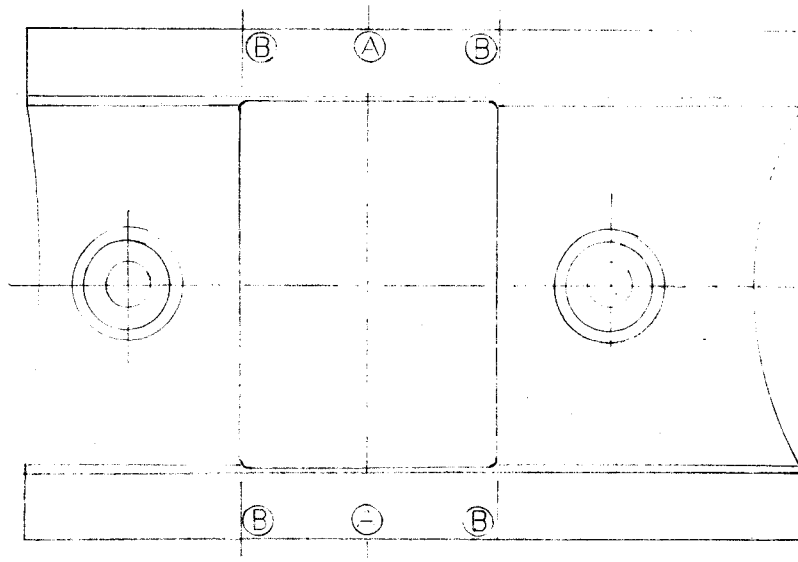

N O R E L C O

THEATRE SERVICE INSTRUCTION #8

MASTER MOTORS

As Used On Projectors Equipped With 2 Motors

DESIGN

The Master Motors used on the Norelco 70/35 Projectors are synchronous type, capacitor start and capacitor run. The design assures constant speed when either 70 mm or 35 mm film is being run if the power line frequency is well regulated. In the U.S. power line frequency regulation is generally excellent. As a result Norelco Projectors do not suffer from speed changes due to load and no sound deterioration from this source is encountered.

POWER LINE VOLTAGE

The locked rotor torque of these motors is sharply increased by high power line voltages. The result is that the starting time for the projector to come up to full speed is reduced below the desirable 2 to 3 second time period. Field tests, in theatres where these conditions have been noted, indicates that a reduction in starting torque can be effected by inserting a suitable resistor in one side of the a-c line to the motor at the projector.

A suitable resistor arrangement can be mounted in a ventilated enclosure on the front or rear of the lower base or underneath the lamp house bracket.

RESISTOR CONNECTIONS

Remove either one of the 20A leads from the right hand terminal of the second terminal strip from the top, in the upper base. Connect one end of the fixed resistor assembly to the vacated terminal. Connect the slider on the second resistor to the 20A conductor previously removed from the terminal. Dress these new wires to the existing cable forms. See Fig. 18 - Page 19 - in Instruction Book No. P 1955.

ADJUSTMENT

Value of the resistance required will vary with the voltage at the projector and the desired starting speed. Move the slider so as to provide approximately 2 ohms resistance. Start the projector and time the interval from the instant of pushing the start button to the instant of full speed. Move the slider to provide a starting time of 2.5 to 3 seconds. Do not insert too much resistance lest conditions of a cold booth or temporary drop in line voltage prevent the motor from starting.

THEATRE SERVICE INSTRUCTION #8

OPERATION

A motor draws about six times the normal running current during the starting phase. The voltage drop through the resistor during the starting phase is relatively high as compared to the reduction when the motor has gone into running phase drawing approximately 4.8 amperes. The starting time is increased without affecting the running characteristics.

MATERIAL REQUIRED

Ward-Leonard Resistor Assembly, consisting of:

- 1 - D8-1/2-RFV-201T-2--1.50 ohm
 - 1 - D8-1/2-RSV-201T-2--1.5 ohm/W
- 608 contact band assembly in cage per 12862.65

OR

IRC 10-1/2 HA 2 ohm adj. 200-225 W

OR

WL Type 200 A 2 ohm adj. 200 W

One Assembly required for each projector.
Procure locally from electrical supply house.

WIRING DIAGRAM

See attached Drawing T.S.I. 8-5 - Page 5.

INSTALLATION AND REPLACEMENT

When a Master Motor is used in the 24 frame position on the NORELCO Projector, it is necessary that the circuit to its 12 MFD. running capacitor be open when the machine is operated at 30 frame speed.

On projectors with serial number 800 and above, this is automatically accomplished when the Speed Selector Switch is set at 30 frames.

On projectors bearing serial numbers in the 600 and 700 series originally equipped with G.E. Motors, the installation of a Master Motor as a replacement must be accompanied by the installation of a Cat. No. 3030-96-TB Switch in place of the existing Cat. No. 3030-96 Speed Selector Switch.

When installing the new switch the 3 existing wires and the strap from the old one are transferred maintaining the same circuitry. On the motor capacitor terminal strip the #71 strap, found connected from the #31 lead to lower #71 terminal should be removed. A new lead is then connected to this vacated #71 and a second new wire is connected to the #31 terminal above.

THEATRE SERVICE INSTRUCTION #8

The opposite ends of these leads are connected to the new switch using the empty terminals closest to the base casting (viewed when the switch is in its mounted position). See attached drawing T.S.I. #8 - Page 5. With this change C-4 (24 frame running capacitor) is removed from the circuit when the Speed Selector Switch is set on 30 frame speed.

Variations occur in spring stiffness of the centrifugal switch in the 30 frame Master Motors. Occasionally operation of the 24 frame speed causes 30 frame motor malfunctioning. This condition can be corrected by adding two wires to the Cat. No. 3030-96-TB Switch, as shown by the dashed lines in Fig. 2, Page 5 of this Instruction. In addition, referring to the motor capacitor panel terminal strip, lead #32 from C-2 is moved down to the nearest unoccupied terminal. The new leads from the Speed Selector Switch are connected to the vacated terminal and to the new 32 terminal. No change in operating procedure is required.

When a G.E. Motor, either 24 frame or 30 frame type, is replaced with a Master Motor the associated Cat. No. 3063-2 Start Capacitor (243 MFD. 110 V. A.C. Electrolytic) MUST be replaced with a 75 MFD. 125 V. A.C. Electrolytic Capacitor. The latter can be procured from a local supplier, or from NORELCO or your theatre supply dealer as (1) Cat. No. 3063-2-M Capacitor. In the remote event of a Master Motor being replaced by a G.E. Motor the start capacitor must be a 243 MFD. unit.

REPLACEMENT PARTS

The following parts are stocked:

Cat. No. 3063-2M Start Capacitor
72-86 MFD 125 V A.C.

Cat No. 3063-3 Run Capacitor
12 MFD 330 V A.C.

Cat No. 3063-1M Motor - Double Shaft
(Upper) 30 Frame Speed

Cat. No. 3064-1M Motor - Single Shaft
(Lower) 24 Frame Speed

Cat. No. 48420 Motor Start Switch
(Internal)

These can be obtained from:

North American Philips Company, Inc.
Motion Picture Equipment Division
100 East 42nd Street, New York 17, N.Y.
or ordered through
Your Theatre Supply Dealer

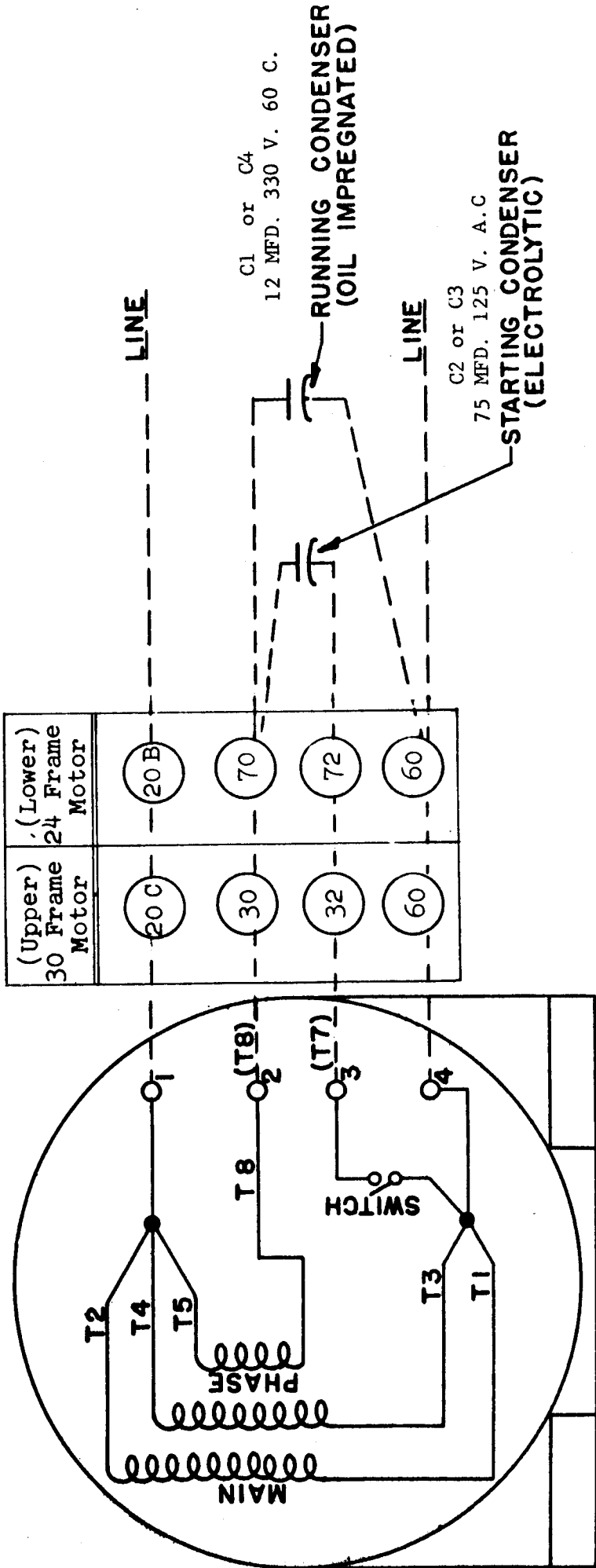

See Fig. 18 Page 19 in Instruction Book No. P 1955

WIRING DIAGRAM & CONNECTIONS

MASTER MOTORS FOR NORELCO PROJECTORS
Equipped With 2 Master Motors

N O R E L C O

THEATRE SERVICE INSTRUCTION #8

FILM SPEED SELECTOR SWITCH 24 - 30 FRAME/SECOND

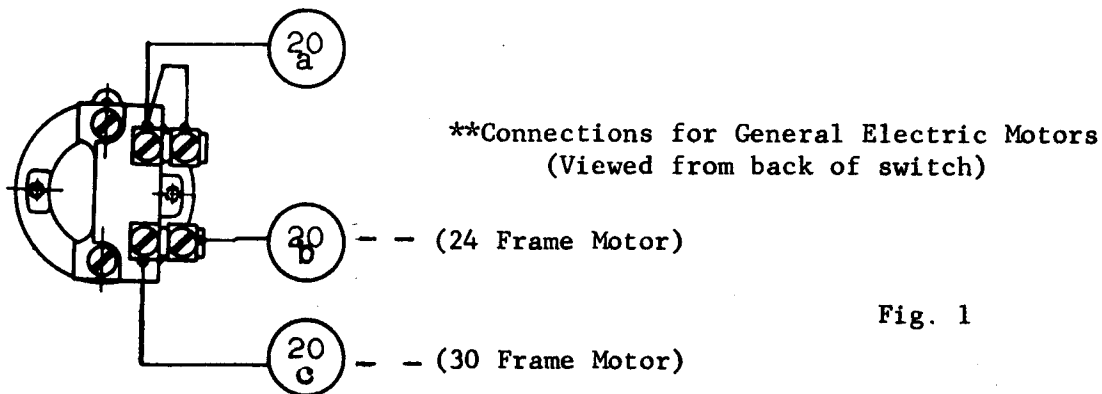

Fig. 1

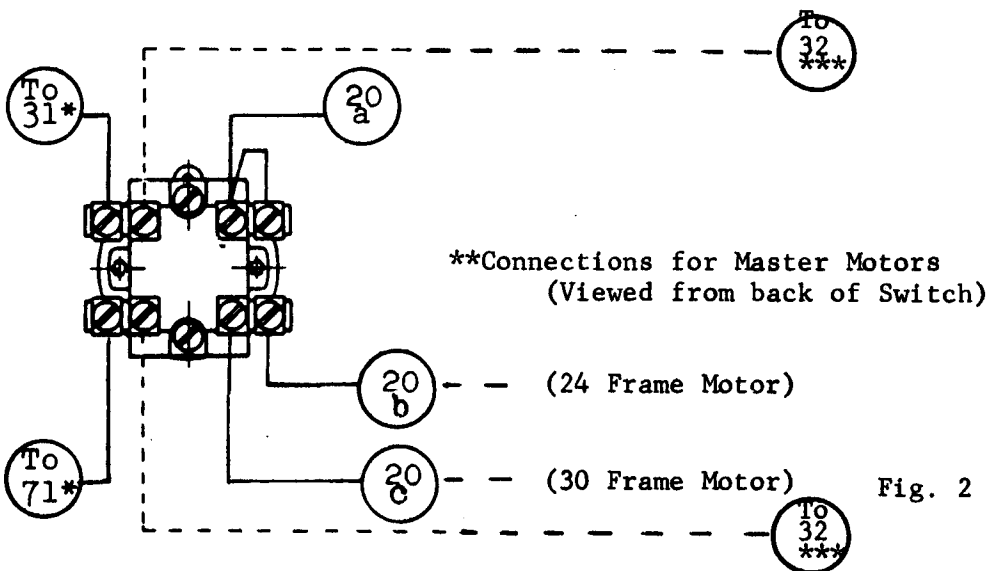

Fig. 2

- *On motor capacitor panel terminal strip - See T.S.I. #8 Pages 2 & 3.
- **Refer to Fig. 18, Page 19 in Cat. P-1955 INSTALLATION AND OPERATING INSTRUCTIONS
- ***On motor capacitor panel terminal strip - See T S.I. #8 Page 3.

This drawing applies only to NORELCO 70/35 Projectors equipped with a 2-Motor Drive

THEATRE SERVICE INSTRUCTION #8

For Model AA II Projectors (Single Motor)

WIRING DIAGRAM

See attached Dwg. T.S.I. 8-7 - Page 7.

DESIGN

The Master Motor supplied with the Model AA II projector is of a synchronous type but of a modified design with a reduced starting torque. With the equipment a 145 MFD 110 V A.C. Start Capacitor and a 5 MFD. 330 V A.C. Run Capacitor are supplied mounted in the upper base. See C3 and C4 on Fig. 11 Wiring Diagram in the Installation & Operating Instructions for the Model AA II Projector.

Where a further increase in starting time, i.e. "slower starting" is desirable, the use of a smaller (C3) Starting Capacitor can be tried. For this purpose a Mallory PSU-108-25 108-130 MFD. 125 V A.C. Capacitor is suggested. This item is not stocked and should be procured through a local electronics supply house.

REPLACEMENT PARTS

The following parts are stocked:

Cat. No.

3063-2M-63 Start Capacitor - 145-175 MFD 125 V A.C.

3063-3M-63 Run " - 5 MFD 330/370 V A.C.

120012 Switch Plate Assembly (Internal)

59373 Torque Cutout (Centrifugal Device - Actuator)

These can be obtained from:

North American Philips Company, Inc.
Motion Picture Equipment Division
100 East 42nd Street
New York 17, N.Y.

or ordered through
Your Theatre Supply Dealer

LUBRICATION

The ball bearings are lubricated at the factory. The relubrication procedure should conform to the manufacturers instructions as shown below.

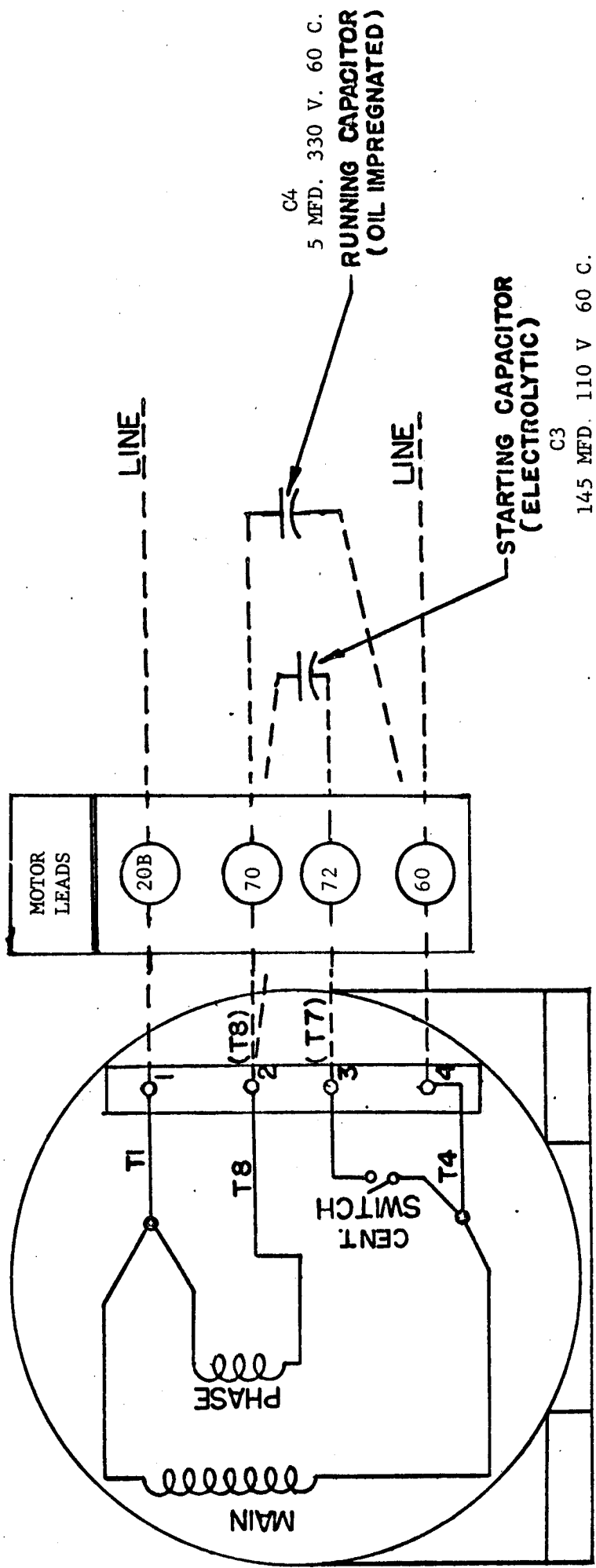

CLOCKWISE ROTATION FACING END
 OPPOSITE NORMAL SHAFT EXTENSION

WIRING DIAGRAM

MASTER MOTORS FOR NORELCO PROJECTORS MODEL AA II
 (Single Motor Drive)

4-22-64 - FJP

THEATRE SERVICE INSTRUCTION #8

Standard Conditions: Operation 8 hours daily, steady load, clean conditions, 100°F. maximum ambient temperature -- relubricate every 3 to 5 years.

Severe Conditions: 24 hours daily, dirty and dusty atmosphere, 100 to 150°F. ambient, relubricate every 1 to 2 years.

Old hardened grease should be cleaned from the bearings, the residue washed out with a clean solvent and, after drying, the bearing repacked with fresh grease of a type recommended below

CAUTION: DO NOT OVERLUBRICATE BALL BEARINGS

GREASES

For temperatures between 0 and 120°F. use one of the following:

N Y. & N J. Lubricant Co.	S58M
Socony Mobil Oil Co.	BRB #1
Standard Oil Co. (Ind.) or	
Standard Oil Co. (N.J.)	Standbar #2
Penola Co.	Andok C
Texas Co.	Regal Starfak #2
Union Oil Co. of Calif.	Strona Light 1
Shell Oil Co.	Cyprina #3 or
	Alvania #2

In addition, MASTER MOTOR-GREASE is available in tubes from:

The Master Electric Co.
Dayton 1, Ohio

WIRING AND FUSES

Wire Size: #14 (Check local requirements)
Fuse Size: 15 ampere

4-22-64 - FJP
North American Philips Company, Inc.
Motion Picture Equipment Division
100 East 42nd Street
New York 17, N.Y.

NOTE:
THIS T.S.I. SUPERSEDES ISSUES DATED
12-20-60/6-15-63 AND ADDENDUM #1
DATED 11-15-61.

N O R E L C O

THEATRE SERVICE INSTRUCTION #9

ROLLER ADJUSTMENTS

Manufacturers' Recommendations for adjustment of the various rollers on the NORELCO 70/35 MM Projector are:

Sprocket Pad Rollers	- 600 Grams Aver.=21 oz.
Magnetic Sound Head Pressure Roller	- 600 Grams Aver.=21 oz.
Magnetic Sound Head Tension Roller	- 400 Grams Aver.=14 oz.
Optical Sound Head Pressure Roller	- 1200 Grams Aver.=42 oz.

PROCEDURE

Replace ornamental cap on roller shaft with a long 8-32 machine screw. Hook a spring balance on temporary screw and measure tension or pressure in a direction perpendicular to roller arm movement.

Adjustments made by loosening associated locking screw, turning polished hexagon nut in required direction and firmly re-tightening locking screw.

Sprocket pad roller adjustments are made by averaging the scale reading when the roller starts to open with the reading when the roller starts to close.

Example: Opening tension 700 G + Closing Tension
500 G = 1200 G + 2 = 600 G

Note: See TSI - #6 for lubrication recommendations.

12-20-60 - FJP
North American Philips Company, Inc.
Motion Picture Equipment Division
100 East 42nd Street
New York 17, N. Y.

N O R E L C O

THEATRE SERVICE INSTRUCTION #10

FIRE TRAPS

Theatre Service Instruction #5 depicts the correct roller assembly for the current model fire trap.

In the Todd-AO manual Fig. 3, Page 2 and Fig. 5, Page 5 shows the correct assembly for the older types of traps.

Threading guards for the small rollers as indicated in T.S.I. #5 are available as Cat. No. X8942-0-1 Threading Guards. A total of 8 would be required for a 2 machine installation that is not already equipped.

In the current model fire trap there is an unused shaft, the purpose of which is explained in T.S.I. #5. This shaft can be removed, if so desired, by pressing it out of the casting after dismantling the assembly from the projector. On the upper fire trap the top left hand shaft is not required for normal operational practice. On the lower fire trap the bottom right shaft is normally unused.

1-11-61 - FJP
North American Philips Company, Inc.
Motion Picture Equipment Division
100 East 42nd Street
New York 17, N.Y.

N O R E L C O

THEATRE SERVICE INSTRUCTION #11

ISSUE 2

NORELCO MAGNETIC CLUSTER CONNECTIONS

Either the 10 track, 6 track, or 4 track NORELCO clusters plug into the Amphenol receptacle portion of the magnetic sound head. When the above receptacle is wired in the standard fashion, pick-up circuits for either the 4, 6, or 10 track clusters used are automatically established.

Present practice includes factory wiring of the Amphenol receptacle using ten 2-wire shielded, jacketed cables, with the shields not connected. The opposite ends of the conductors and shields have been prepared for connection to the sound system. The cables are approximately 6' long and the flexible armored tubing 4' 9" long. An extra #14 conductor is included for sound systems requiring a chassis ground connection.

Drawing 5S 844 77 shows wiring between apparatus in the booth and between both and speakers with a NORELCO EL 5374 - EL 5374 Solid State Sound System.

The following tabulation shows terminations and labeling:

<u>Amplifier Input Designations</u> <u>Drwg. 5S 844 77</u>	<u>Amphenol Connector</u>	<u>Magnetic Tracks</u>	<u>Cable End Markings</u>	<u>Speaker Location</u>	<u>Speaker Designation</u> <u>Drwg. 5S 844 77</u>
	<u>Terminals</u>				
E99-E98-40	1-13	T-AO/70 #1	T-1 (or 1-13)	Left	E
A99-A98-40	2-14	T-AO/70 #2	T-2 (or 2-14)	Left Center	A
B99-B98-40	3-15	T-AO/70 #3	T-3 (or 3-15)	Center	B
A97-A96-40	4-16	C.S. #1	C-1 (or 4-16)	Left	A
B97-B96-40	5-17	C.S. #2	C-2 (or 5-17)	Center	B
	6-18	N.C.	-		
	7-19	N.C.	-		
D97-D96-40	8-20	C.S. #4	C-4 (or 8-20)	Surround	D
C97-C96-40	9-21	C.S. #3	C-3 (or 9-21)	Right	C
C99-C98-40	10-22	T-AO/70 #4	T-4 (or 10-22)	Right Center	C
F99-F98-40	11-23	T-AO/70 #5	T-5 (or 11-23)	Right	F
D99-D98-40	12-24	T-AO/70 #6	T-6 (or 12-24)	Surround	D

#1 70mm sound track is the outside track on the operating side, continuing in sequence to track #6 which is closest to the center casting. CinemaScope tracks, of course, are in the standard arrangement.

The speaker designations shown are as viewed from the projection room.

N O R E L C O

THEATRE SERVICE INSTRUCTION #12

CATALOG NO. 3055 OPTICAL SOUNDHEAD

DESIGN

The Catalog No. 3055 Soundhead in the NORELCO 70/35 projector is provided with a rotary sound drum which is driven by the film. Guide rollers keep the film in close contact with the drum over a large part of its circumference. The starting time of the sound drum is only about 3 seconds.

A condenser system and glass rod causes a very uniform and bright spot of light to be projected on the film. The strongly illuminated sound track is magnified about 13 times by a micro-lens and transmitted on to a screen that contains a slit. Immediately behind the slit is a collimating lens that directs the light beam on to a photocell.

The required pull for driving the sound drum is so small that the film between the sound drum and hold-back sprocket forms a slack resilient loop which absorbs any slight shock caused by the hold-back sprocket or take-up action.

The novel drum design supports the film for practically its full width assisting to maintain accurate film position relative to the micro-lens. This prevention of misfocusing of the sound track adds considerably to the excellent sound quality obtained with this head.

OPTICAL SYSTEM

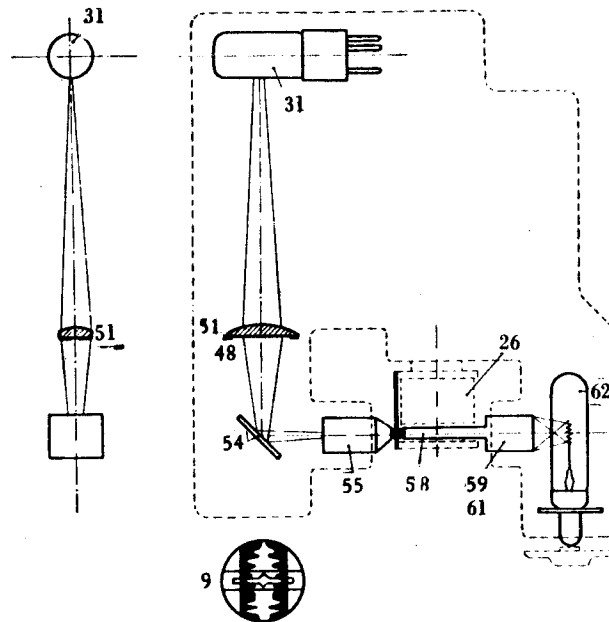

Continued-

62	----	Exciter lamp
59-61	----	Condenser lenses and
58	----	Glass rod
55	----	Micro-lens
54	----	Front surfaced mirror
48	----	Slit
51	----	Collimating lens
31	----	Photoelectric cell

CHECKING AND MAINTENANCE PROCEDURES

If optical sound reproduction exhibits flutter content, especially at the start of a reel the following procedure is suggested. (Reference should be made to pages 23 and 24 in the parts catalog.)

(1) Test the operation of the sound drum and its bearings by lifting the pressure roller at the instant the film tailpiece passes the drum. The drum should continue to rotate for 3 minutes minimum, decelerating to a gradual stop. If not, check for cables or wiring rubbing against the flywheel and for foreign matter in the drum slot adjacent to the glass rod holder. If necessary, dismantle; remove, wash and dry bearings. Test for smoothness and relubricate with light spindle oil.

To dismantle the drum and flywheel for bearing servicing, the entire soundhead should be removed from the projector after disconnecting the exciter and p.e.c. cables. Prepare a clean bench in a clean room before proceeding with the dismantling. Remove the exciter lamp, the C1 407 94 condensing lens system (see (A) below) and the entire p.e.c. housing. Tie back the C1 406 90 pressure arm to disengage the pressure roller from the drum or remove the locking screw, adjusting nut, spring, pressure arm assembly and steel washer. Clamp or firmly support the soundhead with the sound drum pointing downwards. Carefully tap the X50542 pin out of the stabilizer flywheel and shaft. Remove sounddrum and shaft by carefully pulling downwards then remove flywheel, the 22 439 37 spacer and the upper ball-bearing. Remove one of the B045 AF/32 snap rings at the lower ball-bearing and remove this bearing. (A pair of Waldes Truarc #1 pliers will facilitate removal of snap rings.) Wash the bearings in a filtered solvent, benzine if the bearings are not varnished, lacquer thinner if they are. Do not spin an unlubricated bearing. After careful washing and drying lubricate with light spindle oil and test for smooth running. Rough bearings should be replaced. Reassemble in reverse order. Keep away from dust and dirt. Test for smooth running of the drum, before reinstalling the soundhead in the projector, with soundhead in normal working position.

(2) Check the lateral position of the pressure roller. If it is too far off center a flange might be pressing against one side of the drum hampering free rotation. However, this fault should be self-evident because of the need for lateral adjustment with a buzz-track test film.

Continued-

(3) Clean the ball bearings in the pressure roller, dry thoroughly and test for smoothness. Relubricate generously with Shell Macoma #78 Oil, Caltex Thuban Compound, 600W Gear Oil or Philips #8657-00 Oil. If the pressure roller assembly rotates too freely flutter can result. The pressure roller should have the slightest perceptible and play. Adjustment can be effected by loosening the X20592 set screw and shifting the Cl 407 81 thrust collar as required.

(4) It should be noted that badly shrunken film would exhibit a tendency to weave laterally causing an undesirable soundtrack displacement. To avoid this the pressure roller shaft in Cl 406 90 arm assembly is not parallel to the sound drum. Instead the front end of the roller spindle is positioned 0.0027" higher and 0.004" to the right of being parallel. This keeps the film against the front flange of the pressure roller. In the case of excessive soundtrack weave which is definitely established as not being a fault in printing, replacement of the Cl 406 90 arm assembly is indicated as part of the corrective procedure.

(5) Adjust the pressure of the pressure roller on the drum to 1200 grams. (See T.S.I. #9).

* * * * *

The optical system is properly adjusted before the soundhead leaves the factory. Readjustment is usually only required when a part in the optical train is replaced. Adjustment should be made by a skilled technician equipped with proper test films and meters.

* * * * *

If optical sound reproduction indicates a need for adjustment of the optical train because of poor quality one or more of the following steps can be taken:

(a) Replace exciter lamps with blackened envelope or distorted filament. Make sure the notch in the pre-focus base engages the pin located between 7 and 8 o'clock in the holder. Check all screw connection and spring contacts.

The Cl 407 75 exciter lamp holder is held in the main casting by slotted set-screws, sealed with lacquer.

(b) Clean exposed surface of condenser assembly (through exciter housing), end of glass rod (at drum slot) and ends of objective

Continued-

lens assembly. Carefully remove 22 439 16 cover assembly to reach rear element, but do not touch front surfaced mirror with fingers. If necessary, replace the 22 439 21 mirror. Also clean p.e.c. envelope or replace p.e.c. and clean surface of collimating lens visible through p.e.c. housing. To remove the 22 439 32 objective lens assembly, dismount the 22 439 16 cover assembly, the X798-2 locking screw, 22 439 24 locking plate and the 22 439 23 eccentric pin. Objective assembly can then be pushed into the light housing. Readjust per (B) below.

If the above procedure does not clear reproduction troubles and the soundhead is still suspect the following steps can be taken, testing between each one to determine results.

(A) Remove exciter lamp. Loosen lacquer sealed set screw and remove the C1 407 94 condensing lens assembly and glass rod. Examine the end of the glass rod with a magnifying glass. If it is damaged replace the entire assembly - do not attempt to dismantle. Be sure the set screw engages in the slot in the assembly when reinstalling the assembly.

Temporarily feed the exciter lamp with an a-c voltage. With an output meter and load resistor across the power amplifier output, move the condensing lens assembly back and forth until the maximum output voltage is obtained. Tighten the set screw and check that approximately 0.02" clearance remains between a film and the end of the glass rod.

(B) If the need for further adjustment is indicated, the use of 6000 c.p.s., 9000 c.p.s. test film, an output meter and a load resistor are recommended.

With 6000 cycle film running through the sound head loosen the X798-2 locking screw, (lacquer sealed) to be found just underneath the 22 439 32 objective lens assembly. Turn the associated eccentric pin 22 439 23 until the maximum meter deflection is obtained. Temporarily tighten the locking screw.

Loosen the X798-2 locking screw that appears at the rear of the soundhead under the C1 407 91 slit assembly. Turn the associated eccentric adjusting pin until maximum output is obtained. A maximum will be obtained with two positions of the pin but the correct position is that in which the C1 407 91 slit holder assembly is nearest the 22 439 21 mirror.

Repeat both of the above operations using 9000 cycle film, slightly turning both eccentric pins alternately until maximum meter reading results. Tighten locking screws and seal with a touch of lacquer.

Continued-

(C) To balance the output level between machines identical 1000 cycle film should be run in each machine and the RL5 balancing potentiometers, in each optical pre-amplifier, adjusted to obtain similar meter readings.

(D) For correction of sprocket hole or framing line pick-up, the soundtrack can be correctly aligned on the slit by the use of a buzz-track test film. Run the projector with the test film threaded and turn the C1 407 82 knurled adjusting screw, as required, until the track is properly located. The soundtrack image magnified 13 times can be observed on the slit through the window in the 22 439 16 cover.

4-28-61-FJP
North American Philips Company, Inc.
Motion Picture Equipment Division
100 East 42nd Street
New York 17, N. Y.

N O R E L C O

THEATRE SERVICE INSTRUCTION #12

ADDENDUM #1

CATALOG NO. 3055 OPTICAL SOUND HEAD

As indicated under "DESIGN" in the body of T.S.I. #12, this optical sound head utilizes the loose loop system. Tight loop systems have been used in some earlier types of optical sound heads. The overall design of the #3055, properly adjusted and maintained, results in reproduction that is wow-free and flutter-free.

The pickup time for a correctly adjusted capstan/flywheel/pressure roller is 5 to 6 seconds. The distance between the "start" and "changeover" cues at the end of a reel is 11 feet representing a time of 7.2 seconds. This should be ample for the 5 to 6 second requirement if the "start" frame in the aperture is "9" or higher.

The following can result in a longer acceleration time and possibly some wow at the beginning of an incoming reel:

- (1) Threading at a point after the "9" frame.
- (2) Oily film.
- (3) Thin base film stock as in some newsreels.
- (4) Improper adjustments.
- (5) Improper maintenance.

Modification of the sound head so as to increase the wrap around area of the film on the capstan has been proposed. This is an undesirable modification. It changes the running characteristic to that of the tight loop system. It can introduce flutter throughout a reel because of sprocket hole modulation.

The film is normally pushed against the capstan by the pressure roller in the sound head. This produces friction which causes the capstan to revolve as the film moves. Friction is the product of the friction co-efficient and the pressure. Increased contact area does not enter into this formula.

THE PREFERRED METHOD OF DECREASING THE ACCELERATION TIME (after checking the procedures outlined on pages 2-3 of T.S.I. #12) IS TO INCREASE THE PRESSURE OF THE ROLLER ON THE CAPSTAN TO THE REQUIRED POINT. This is readily done by loosening screw #28 - Fig. 15 page 24 in the Parts Catalog and turning adjusting nut #29 clockwise - then tightening the #28 screw.

8-18-65 FJP
North American Philips Company, Inc.
Motion Picture Equipment Division
100 East 42nd Street
New York, N.Y. 10017

N O R E L C O

THEATRE SERVICE INSTRUCTION #13

ISSUE 2

INSPECTION OF PROJECTOR DRIVING MECHANISM

The record of trouble-free operation of the Norelco 70/35 Projector does not preclude periodic inspections of the driving mechanism. A convenient inspection interval could be at the time of each oil change (see paragraph 25, page 23 in the Instruction Manual). At this period gears should be carefully examined for wear or the need of adjustment, pins and screws checked for tightness, and the intermittent flywheel shaft checked for end-play.

GEAR ADJUSTMENT

All gearing, of course, is precision fitted in manufacture. Two adjustments are provided to compensate for wear or if new parts and installed.

Referring to page 12 in the parts catalog, the C1 750 15 idler bracket (Index 15) can be moved so as to adjust the backlash of the C1 750 11 drive idler (Index 13) relative to the intermittent (Index 7) and the C1 750 09 worm gear (pages 34-35/Index 13). This adjustment is accomplished by loosening the three X1170-2 screws (page 12/Index 17) and shifting the bracket. The X1170 screws, located behind the lens* mount and at the framing shaft bracket, should be firmly retightened. Following the relocation of the C1 750 15 idler bracket, the C1 750 10 fork must be checked for freedom of movement by (1) framing to one extreme position, (2) framing to opposite extreme position, and (3) framing to mid-position (normal). In each position the fork should be lifted manually and observation made to see that it automatically falls back to its original position. If any binding is present the C1 750 15 bracket must again be reset or one side of the bracket filed or machined slightly to increase clearance from the fork.

Referring to page 9 in the parts catalog, the entire shutter shaft and bracket assembly can be moved to adjust play between the C1 750-21-3 shutter shaft (Index 1) and the C1 750 24 fibre gear (page 35/Index 11). Loosening the four X1170-2 screws (page 9/Index 14) allows shifting of the shutter shaft bracket as required. The screws should, of course, be firmly retightened.

INTERMITTENT MOUNTING

The mounting of the intermittent movement should be checked upon the installation of a projector. Rough handling during shipment can result in distortion of the C1 704 19 retaining clips that clamp the C1 050 15 framing gear segment (page 12/Index 6) in the main casting.

THEATRE SERVICE INSTRUCTION #13

ISSUE 2

To do this the intermittent assembly should be grasped at the flywheel area and vigorous efforts made to move it back and forth. If there is any movement of the C1 050 15 framing gear segment, relative to the main casting, the C1 704 19 clips should be tightened or replaced as required. Two clips are used, one above and one below the intermittent sprocket shaft center line.

INTERMITTENT ADJUSTMENT

Recommendations for field adjustments are based on the following final check procedure used in manufacture:

- (1) Hold the intermittent movement in a vertical position standing on the sprocket shaft. Do not exert pressure, but allow the weight of the movement to control the pressure.
- (2) Turn the flywheel and determine if the motion is free even through the 4 pull down positions.

The flywheel shaft (with driving pin) has a ground conical center point at each end. These center points run in the hardened recessed cones of two special screws that act as bearings. Each of these screws is locked in its required position by a second screw and a leather pressure disc.

If the tests (1) and (2) indicate need for adjustment the locking screws should be loosened about 1 turn. (Referring to page 39 - Figure 31 of the Instruction Book, one of these locking screws appears in white, to the right and diagonally above one of the black bearing screws. The second set of screws is on the opposite end of the flywheel shaft.)

The bearing screws can then be turned to provide proper movement as specified in (2) above. Turning the screw on the flywheel end clockwise will reduce the clearance between the pin and cam. Turning the screw at the sprocket end clockwise will increase the clearance. The adjustment must be done carefully by a competent person. The end play of the flywheel spindle, after adjustments are made and locked, should be .00012" to .0002". All tests should be made as in (1) above.

4/28/64 FJP
North American Philips Company, Inc.
Motion Picture Equipment Division
100 East 42nd Street
New York 17, N.Y.

N O R E L C O

THEATRE SERVICE INSTRUCTION #114

61-704-24 UPPER PRESSURE - BAND HOLDER

A design change has been made on this assembly. The parts now in use in theatres can be modified in projection rooms, so as to make them equivalent to the new type holders. The change involves the removal of the angled corners of the arms into which the 35 mm pressure band flanged studs are pressed. (See Index 114, Page 19 - Parts Catalog.) On some projectors these arms are lacquered yellow and green.

This modification is desirable and the following procedure is suggested:

- (1) Place cooling plate in open position, remove pressure bands, withdraw cooling plate from holder and dismount upper pressure band holder after removing the four (4) X-3612-2 screws and washers.
- (2) Figure-1 of this bulletin shows the top view of the holder. The dotted lines indicate the limits to which the top portion of the inner arms are to be removed. Simply measure $7/32$ " from the corner edges and scribe a line on the top of each arm.
- (3) Figure-2 shows a side view of the inner (green) arm. On the angled front surface of the inner arms measure down $7/32$ " from the top corner and scribe lines. These lines should locate so as to strike the approximate centers of the ends of the studs on which the 70 mm bands are fastened.
- (4) On the inner sides of each 35 mm arm scribe a third line connecting the ends of the lines mentioned in (2) and (3) above.
- (5) Use a medium cut, safety edge, flat file or a small grinding wheel, remove the angled corners down to the scribed lines. Do not cut into 70 mm band studs. The new corner on the front of the modified arms should appear close to the center point of the ends of the 70 mm band studs. Smooth all edges. The side view of a modified arm is shown in Figure 3.
- (6) Reinstall in reverse of procedure in (1) above.

12-29-61 F.J.P.
North American Phillips Company, Inc.
Motion Picture Equipment Division
100 East 42nd Street
New York 17, N. Y.

Continued

N O R E L C O

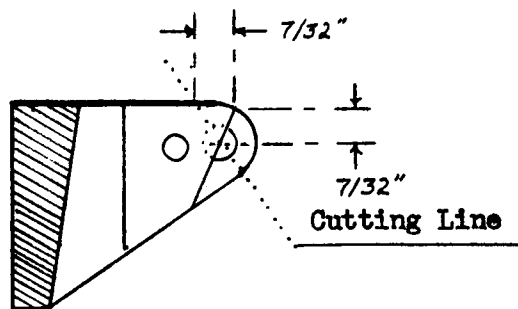
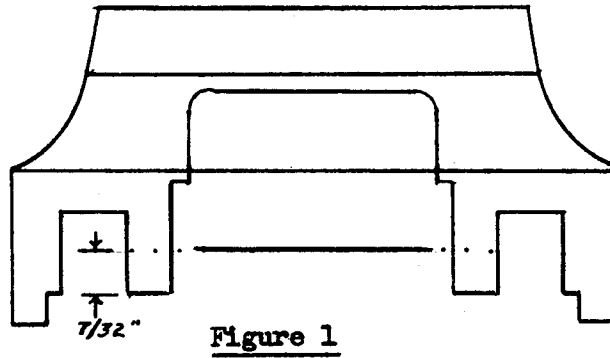

Figure 2

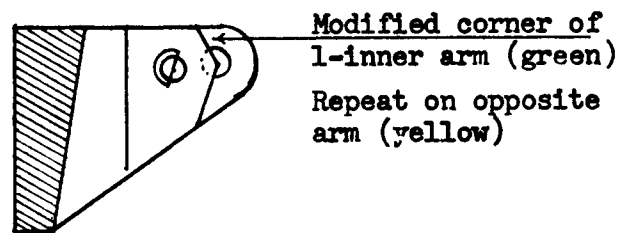

Figure 3

CL 704 24 UPPER PRESSURE BAND HOLDER

N O R E L C O

THEATRE SERVICE INSTRUCTION #15

FILM GATES - 70/35 PROJECTOR

The "fixed" or unsprung film edge guide roller on both the 70mm and 35mm film gate assemblies should of course be at the outside of the gate, closest to the projectionist.

C1-606-15 FILM GATE - 70MM

The correct dimension, "A" below, from the film contacting surface of the "fixed" guide roller to the flat machined surface on the back of the gate casting is $4.5257" - 0.002"$.

C1-606-34 FILM GATE - 35MM

The correct dimension, "A" below, from the film contacting surface of the "fixed" guide roller to the flat machined surface on the back of the gate casting is $3.8367" - 0.002"$.

The leaf springs for the inner guide rollers should be lightly tensioned by the adjustment screw to provide steady and positive film guiding. Excessive pressure can cause cupping of the film that might introduce focusing problems.

The edge guide rollers should be lubricated as instructed on Page 1 of T.S.I. #6. Rollers must be replaced if they become grooved or run untrue.

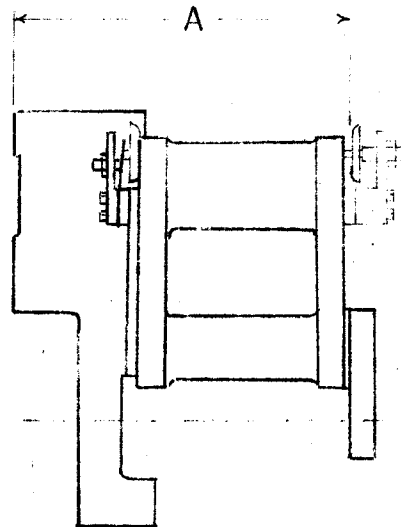

10-10-62
Fred J. Pfeiff
North American Philips Company, Inc.
Motion Picture Equipment Division
100 East 42nd Street
New York 17, N.Y.

N O R E L C O

THEATRE SERVICE INSTRUCTION #16

C1 902 11 DOWSER ARM ASSEMBLY

A new type of assembly is now available. It is of one piece construction and has a larger pivot bearing. The chrome-iron material used has increased heat resistance. This is a desirable feature when high powered arc lamps are used. However, it is not good practice to subject any dowser blade to unnecessary exposure to the concentrated light beam.

INSTALLATION

To prevent bouncing of the blade when it drops to the closed position it will be necessary to modify the C1 703 57 bracket on which the terminal strip is mounted.

Referring to the sketch below, the shaded area should be filed or cut away. A small piece of felt approximately 1/8" x 1/8" x 3/4" long, (cut from a #3030-16 friction disc) is then carefully cemented in the cut out area. Pliobond cement or a similar heat resistant adhesive can be used, but sparingly.

When the cement has set the felt should be soaked with heavy gear oil (such as used on the take up discs, the lens slides and in the optical soundhead pressure roller bearings).

In reassembly the travel of the dowser arm must be adjusted so that:

- (a) In its open position the top short edge of the dowser blade does not hang up on the edge of the C1 902 14 bracket on which the solenoid is mounted.
- (b) In its closed position the bottom of the dowser arm should drop about 5/64" below the normal position of the top of the C1 703 57 bracket. This is to prevent the bottom of the plunger in the solenoid from striking the bottom of the solenoid housing, which could cause bouncing of the dowser.

The proper position is obtained by the amount of engagement of the threaded end of the solenoid plunger in the C1 902 10 yoke. The hex nut on the threaded end of the plunger should be tightened after effecting the proper adjustment.

When a new type dowser arm assembly is installed the original C1 703 56 shoulder screw and X 24000 cotter pin are discarded.

Refer to T.S.I. #1 & #4

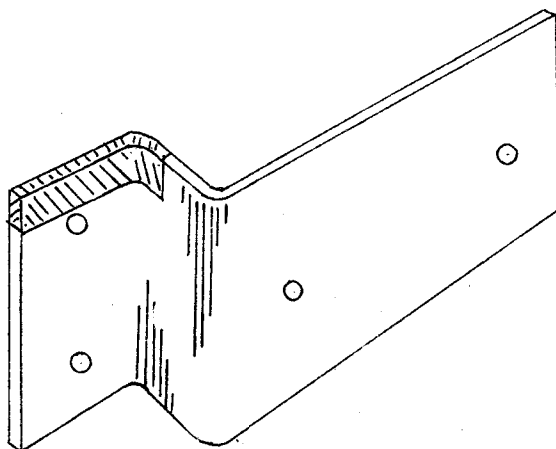

C1 703 57 Bracket

4-28-64 F.J.P.
North American Philips Company, Inc.
Motion Picture Equipment Division
100 East 42nd Street
New York 17, N.Y.

N O R E L C O

THEATRE SERVICE INSTRUCTION #17

C1 750 48 MAIN DRIVE GEAR (FIBRE)

C1 750 66 MAIN DRIVE SHAFT PINION (STEEL)

Future orders for either of the above parts will be filled by shipment of a C1 754 65 gear set, which consists of a fibre gear with a modified modulus and a matching steel pinion.

If either the C1 750 48 gear or the C1 750 66 pinion require replacement then the C1 754 65 gear set must be installed in place of both the original items.

On page 33 of your Parts Catalog refer to Index No. 17 and cross out "C1 750 66". Insert "C1 754 65 gear set".

On page 35 of the catalog refer to Index No. 21 and cross out "C1 750 48". Insert in its place "C1 754 65 gear set".

1-3-63 F.J.P.
North American Philips Company, Inc.
Motion Picture Equipment Division
100 East 42nd Street
New York 17, N. Y.

N O R E L C O

THEATRE SERVICE INSTRUCTION #18

APERTURE PLATES

General:

Aperture plates with full size openings are properly useable only when the horizontal and vertical angles of projection are zero. In a 2-machine projection booth only one machine can conceivably meet this requirement. In practice each machine is spaced more or less equidistant from the theatre center line, so each has a slight horizontal projection angle. In most instances some vertical angle is generally also present. To correct the keystones due to the projection angles it is general good practice to file apertures of a compensating shape.

The limitations prescribed by the focal lengths of lenses, screen dimensions and possible viewing sight line restrictions, can also contribute to the need for filing apertures to accommodate all conditions. Ordinary lens focal lengths are graduated in steps of 1/4" (0.25"). ISCO lenses have closer gradients of 1/5" (0.2"). It can occur that the use of a particular focal length would result in a picture size slightly smaller than the available screen area and, using the next shorter focal length the picture would overlap the screen. In such a case and within the dictates of good judgment the shorter focal length might be used with a slightly reduced aperture.

The professional method of determining aperture dimensional requirements is to project one of the standard target films, without an aperture, through the lens that is intended to be used. By reference to the applicable dimension points as projected on the screen the positions for the screen maskings can be determined. After the screen maskings are installed, for the indicated rectangular shape, then an undersized or blank aperture is filed to produce clean, sharp edges at all 4 masks. Suitable target film can be purchased from the Society of Motion Picture and Television Engineers. Code APAL film is suitable for use for CinemaScope - optical and 35 mm projection. For 70 mm use Code PA 70 test film is available.

APERTURE PLATES - NORELCO 70/35 PROJECTORS

Undersized aperture plates became available in the fall of 1963.

The following sizes can then be ordered:

<u>Cat. No.</u>	<u>Marking</u>	<u>Opening Size</u>	<u>Engraved Guide-Line Dimensions</u>
146 00347	35	.681" x .354"	.823" x .599"
146 00348	CS-0	.681" x .650"	.839" x .713"

THEATRE SERVICE INSTRUCTION #18

<u>Cat. No.</u>	<u>Marking</u>	<u>Opening Size</u>	<u>Engraved Guide-Line Dimensions</u>
146 00349	70	1.394" x .646"	1.913" x .866"
C1 704 71	D 70	Pin hole-center	Vert. & Hor. Cross lines

146 00347 (C1 755 03)

This plate is intended for filing out to any of the currently used ratios for non anamorphic film such as:

2.00:1825" x .412"
1.85:1825" x .446"
1.75:1825" x .472"
1.66:1825" x .497"
1.37:1825" x .600"

The engraved guide lines denote the maximum opening for the standard 1.37:1 ratio.

All aperture plates have the same external dimension so that the 146 00347 plate can also be used for CinemaScope and/or 70 mm by merely filing beyond the engraved lines to the required dimension.

146 00348 (C1 755 04)

This plate is primarily intended for filing out to the dimensions required for CinemaScope-Optical films. However, it may also be used for 70 mm films by filing out beyond the engraved lines to the required dimensions.

146 00349 (C1 755 05)

This plate is useable only for 70 mm film and should be filed out as close to the engraved lines as is possible within the limitations imposed by the projection angles and lens E.F. By no means should plates be used as received. To do this wastes light and causes loss of photographed information on the screen.

1/8/65 - FJP
North American Philips Company, Inc.
Motion Picture Equipment Division
100 East 42nd Street
New York 17, N.Y.

N O R E L C O

THEATRE SERVICE INSTRUCTION #18

ADDENDUM #1

APERTURE - LIGHT GATE CLEARANCE

The current factory setting provides a 0.079" (2mm) clearance between the aperture plate and the closest point on the curved runner plate.

It is believed that this practice has contributed substantially to the records for long film life (more than 1500 runs per print) that have been established using NORELCO 70/35 projectors.

On the latest production of NORELCO AAI projectors the clearance between the aperture plate and the runner plate can be adjusted by shifting the C1 755 74 notched plate which is part of the projector.

However, in the interest of preventing film damage with possible expense to the exhibitor we must caution against any substantial reduction in clearance, whether by shifting the notched plate or resorting to other modifications that reduce the safety factor.

Measurements have been made indicating that as much as 0.032" film buckle, in the direction of the light source, can occur with 35mm film. The amount of such distortion can increase with wider gauge film and is influenced by the temperature and the adjustment of the light source. One device which has been offered as a means for controlling the film excursion, in order to improve focus, actually only maintains the film in its distorted shape while it is in the aperture.

Examination of the NORELCO projector will readily reveal that as the aperture is moved toward the runner plate, by shifting the notched plate, parallelism between the aperture and the curved runner plate no longer holds. This results in slightly greater spacing between the bottom edge of the aperture plate and the film as compared to the top edge. Since the film buckle occurs in the aperture this slightly greater clearance at the exit can offer additional assurance against film damage.

Most authorities agree that dark colored masking around the projected picture is desirable if only to isolate the display from the surrounding areas. This helps focus the viewer's attention on the screen and also provides a non-reflecting area which absorbs the edges of the projected image. Dark masking also provides another marked advantage, not generally appreciated, in that it improves the effective contrast around the perimeter of the screen image. Light colored masking or screen borders can result in spurious and distracting reflections and might degrade the screen image.

8/31/65 FJP
North American Philips Company, Inc.
Motion Picture Equipment Division
100 East 42nd Street
New York, N.Y. 10017

N O R E L C O

THEATRE SERVICE INSTRUCTION #19

TAKE-UP DRIVES ON 70/35 PROJECTORS MODEL AAI

See page 5 of Installation Instructions for the AAI projector regarding shaft alignment procedures.

Screws "A" and "B" shown on the accompanying Figure 1 should be checked for tightness upon installation and as a regular service function.

Screw "A" is located at the right side of the bracket and behind the large bevel gear.

Before tightening the screws the gear alignment at "C" should be checked and corrected if necessary. This precaution also applies to the depth of mesh of the gears. A slight amount of back-lash is generally required to assure quiet running.

Correct "C" adjustment is accomplished by loosening "B" and shifting the associated Cl 051 11 bearing separator, up or down as required, to align the edge angles of the two gears. Tighten "B" well.

Correct depth of mesh is accomplished by loosening "A" and shifting the associated Cl 050 23 bearing separator in or out as required. Firmly tighten "A".

* * * * *

Coat the gear teeth with graphite grease per instructions in T.S.I. #6. Repeat periodically as required and inspect for wear after cleaning.

* * * * *

Regularly remove the take-up shaft extension from between the take-up assembly and the projector head. Clean both ends and relubricate generously with ball bearing grease (EL 4850). Repeat every 3 months or more often if duty cycle requires.

* * * * *

Keep the 3030-16 Felt friction disc impregnated with EL 8657 Oil or equivalent as noted in T.S.I. #6. Replace worn felts with new well-soaked ones.

* * * * *

Periodic lubrication of the reel shaft latches on both 35mm and 70mm shaft extensions will contribute to longer life and smooth, trouble-free operation.

THEATRE SERVICE INSTRUCTION #19

Latches that stick in operation because of inadequate lubrication can usually be freed by the application of a penetrating type of oil. This should be followed by periodic lubrication as indicated in T.S.I. #6.

* * * * *

Figure 1 of this instruction depicts the current assembly of the driving portion of the take-up assemblies.

Figure 2 shows the earlier version supplied prior to the latter part of 1962.

If pressure is applied against the threaded end of the shaft, at the friction adjusting nut, and the shaft can be moved toward the reel side some short amount then the assembly is of the Fig. 1 type. If no movement, under pressure, results then Fig. 2 applies.

The study of the two figures will reveal the differences in construction. When changing the reel shaft or the bearing section of the reel shaft, new types of shafts will be found to be without the snap ring at "D" Fig. 2. In such instances a plain washer must be substituted for the original "snap" ring. The washer should fit freely on the shaft and have the following approximate dimensions: 1/2" I.D. x 23/32" O.D. x 3/64" thick.

7-28-64 - FJP
North American Philips Company, Inc.
Motion Picture Equipment Division
100 East 42nd Street
New York, N.Y. 10017

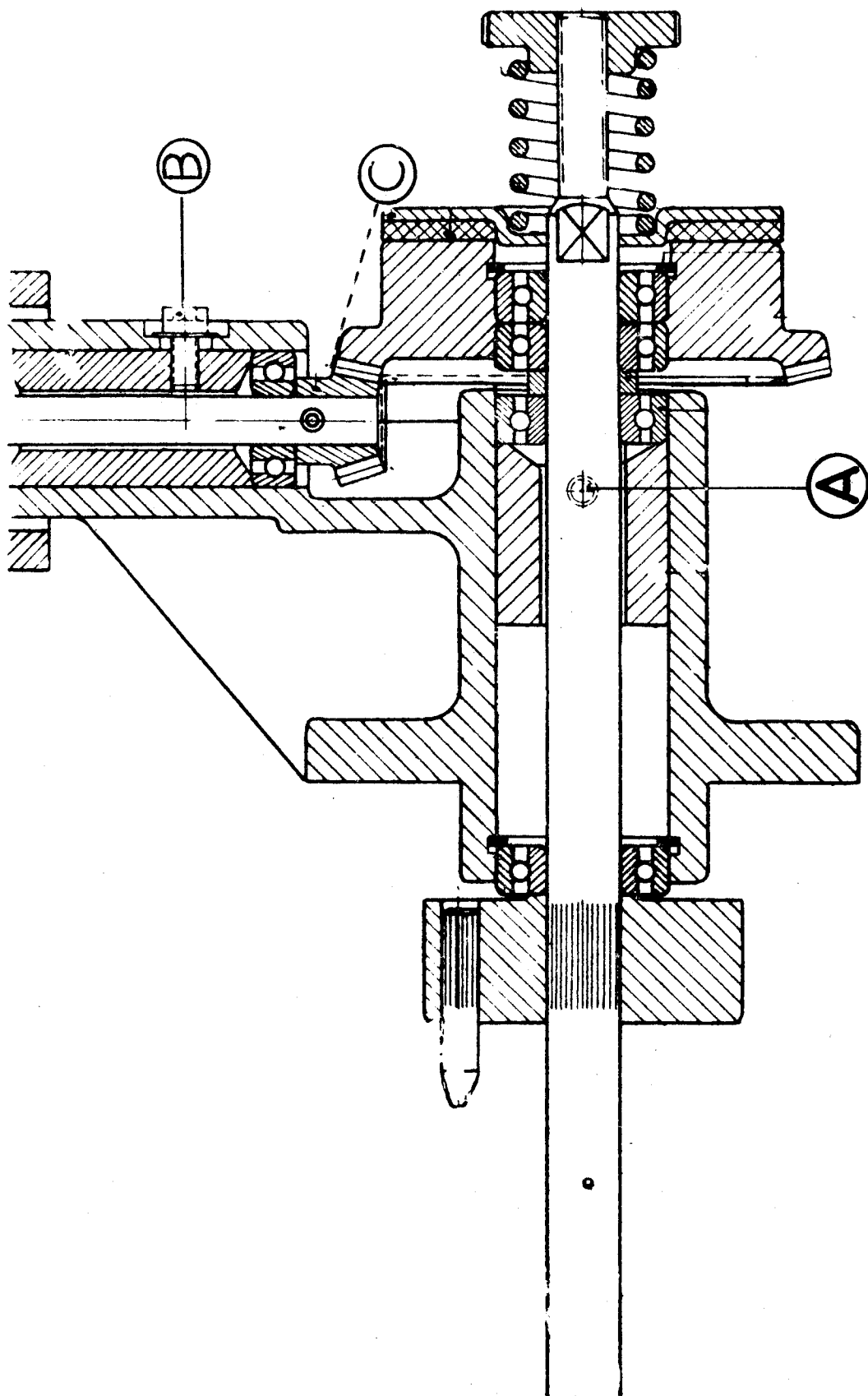

Fig. 1

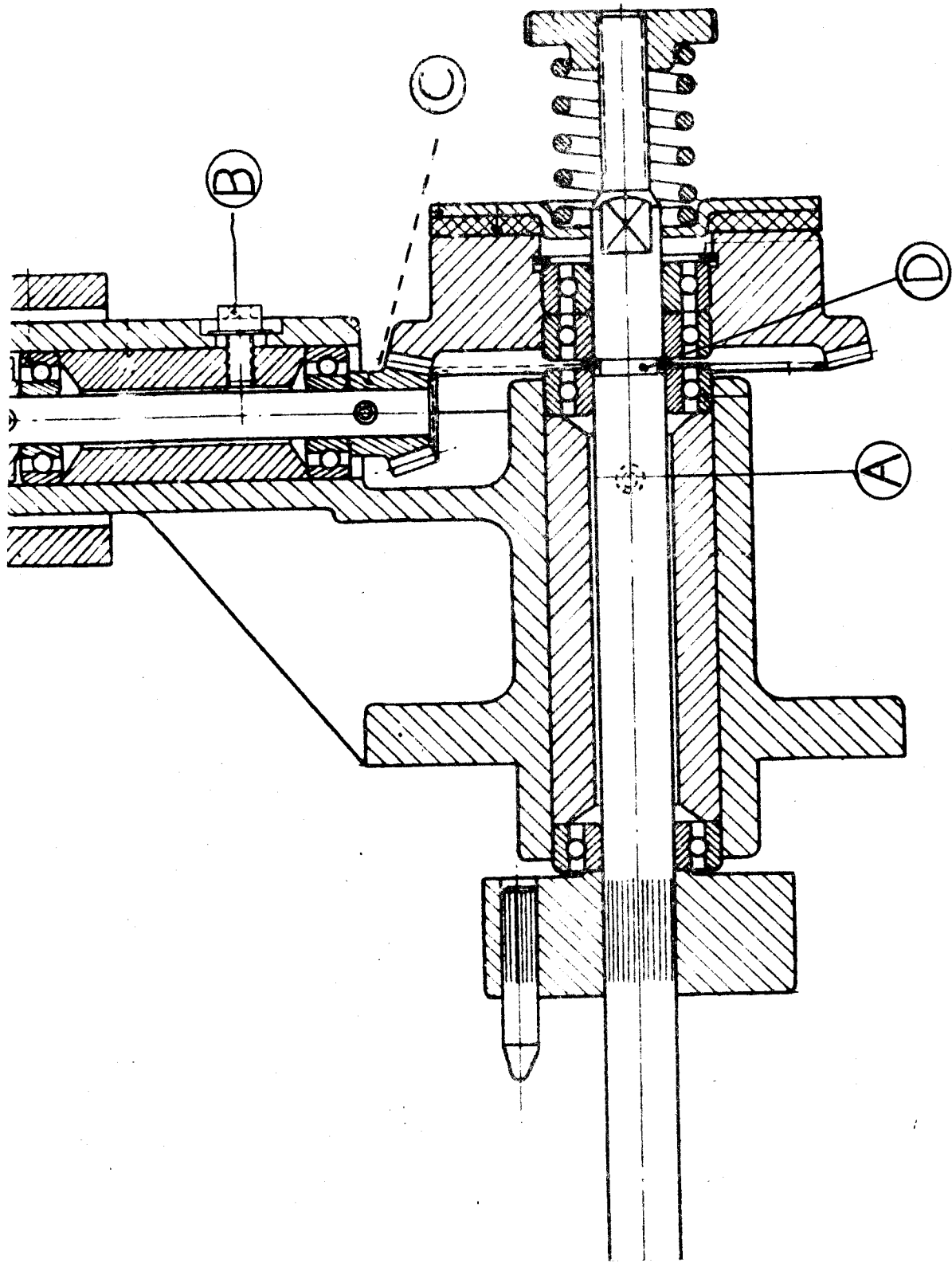

Fig. 2

N O R E L C O

THEATRE SERVICE INSTRUCTION #20

MAGNETIC CLUSTERS

The various magnetic clusters available for use in the NORELCO 70/35 projector are equipped with Amphenol 26-159-24 plugs. The contacts on this plug are gold plated on a heavy silver base plating to minimize contact resistance. Gold has long been recognized as being highly resistant to oxidation which is recognized as being a major cause of contact problems.

It has been determined however that these surfaces of the gold plated contacts can become contaminated. The possible causes for this are being investigated. Included is the affect of the chemicals used in the manufacture of the boxes in which the assembled cluster is packaged.

Accordingly, before classifying NORELCO Cat. #3021, #3024 or #3026 Magnetic Cluster as being defective, erratic or noisy, the contacts on the Amphenol 26-159-24 plug should be burnished.

Use a burnisher that will remove only the oxidation and not the gold plating.

In the order of increasing roughness of such a "tool" we suggest:

- (1) A pencil eraser
- (2) An ink "
- (3) #400 Wet/Dry paper

DO NOT USE SANDPAPER - GARNET PAPER - EMERY CLOTH -
A SHARP SCRAPER OR SIMILAR METHODS.

8/10/65 FJP
North American Philips Company, Inc.
Motion Picture Equipment Division
100 East 42nd Street
New York, N.Y. 10017

N O R E L C O

THEATRE SERVICE INSTRUCTION #21

C1 708 82 KIT

This kit contains the following assortment of screws, washers and nuts for use as replacement items:

<u>Quantity</u>	<u>Cat. No.</u>	<u>Item</u>	<u>Description</u>
2	B086 AF/10N x 1/2"	Screw	10-32 x 1/2" L
4	B080 AD/1/4 x 1/2"	Screw	1/4-20 x 1/2" L
4	B053 AD/6	Lockwasher	
2	B079 AF/10N x 1/2"	Screw	10-32 x 1/2" L
2	B089 AD/10N	Hex Nut	10-32
2	B053 AD/5	Lockwasher	
4	B082 CD/5/16 x 1-1/4"	Screw	5/16-18 x 1-1/2" L
4	B050 AD/8	Washer	
2	C1 050 84	Knurled Screw	
2	C1 050 85	Spacer	
1	30 650 28	Container	
1	JW 251 00	Hook	
1	B085 AD/8N	Hex Nut	8-32
2	B084 AF/8N x 1/4"	Screw (Hol.Hd)	8-32 x 1/4" L
2	B088 AF/10N x 3/16	Screw	10-32 x 3/16" L
2	B084 CF/8N x 1/2	Screw	8-32 x 1/2" L
2	B084 CF/4N x 5/16	Screw	4-40 x 5/16" L
2	B050 CD/4	Washer	
2	B050 CD/5	Washer	
2	B050 CD/6	Washer	
2	B049 AH/5	Lockwasher	
2	B086 AF/10 x 3/4"	Screw(Hol.Hd.)	10-32 x 3/4" L
2	B081 AF/8N x 1/2"	Screw(Hol.Hd.)	8-32 x 1/2" L
2	B081 AF/1/4 x 5/8"	Screw(Hol.Hd.)	1/4 - 5/8" L
2	B081 AF/4N x 3/8"	Screw(Hol.Hd.)	4-40 x 3/8" L
2	B080 AD/2N x 1/2"	Screw	2-56 x 1/2" L
2	B080 AD/4N x 3/8"	Screw	4-40 x 3/8" L
2	B080 AD/8N x 1/2"	Screw	10-32 x 1/2" L
2	B085 AD/8N	Hex Nut	8-32
2	B085 AD/1/4"	Hex Nut	8-32

N O R E L C O

THEATRE SERVICE INSTRUCTION #22

MAGAZINE REEL SHAFTS

NORELCO Model AAI projectors are equipped with "split" shafts so that normal 35mm reels having a 5/16" bore as well as 35 and 70mm reels with a 1/2" bore can be used.

The one piece 1/2" diameter shafts originally supplied were -

Cat. 3030-508 for Upper Magazine
Cat. 3030-509 " Lower Magazine

For the upper magazine the new style shafts consist of -

Cl 426 67 Bearing Section
Cl 426 61 70mm Reel Extension
Cl 426 63 35mm Reel Extension

For the lower magazine the new style shafts consist of -

Cl 426 66 Bearing Section
Cl 426 61 70mm Reel Extension
Cl 426 63 35mm Reel Extension

Note that the bearing sections are usable with both 35mm reel and 70mm reel extensions.

When a new style shaft assembly is installed in place of the original one-piece shaft in the lower magazine the snap ring, Index 43 - Fig. 17 - Page 26 in the parts catalog, is not used. Instead a Cl 413 06 washer is used as shown at "A" in Fig. 1 below.

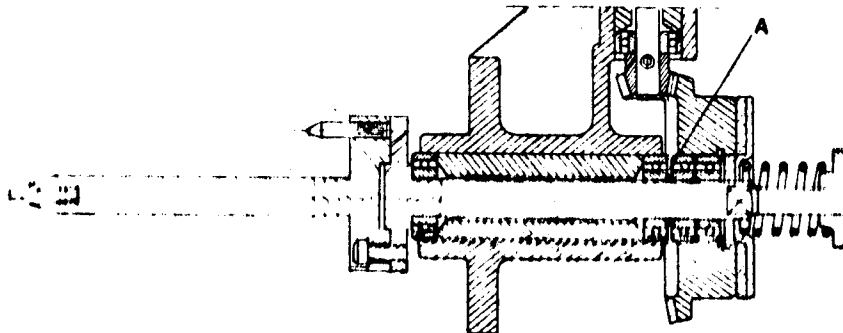

THEATRE SERVICE INSTRUCTION #23REPLACING MAIN VERTICAL SHAFTFOR PROJECTORS EQUIPPED WITH 2 MOTORS

- (1) Turn off A.C. to projector at distribution panel.
- (2) Frame to center point - (White line in center of viewing hole).
- (3) Remove gear case cover.
- (4) Drain Oil.
- (5) Remove oil distribution tube assembly.
- (6) Remove belt guards and raise the lower motor to the highest possible position and tighten one hex head screw.
- (7) Remove belt from lower pulley.
- (8) Remove upper motor and support suitably to avoid need for disconnecting.
- (9) Remove 6 hollow head screws that hold belt housing to projector and support motor and housing suitably to avoid need for disconnecting motor.
- (10) Remove oil pump assembly (4 screws).
- (11) Remove the main drive shaft bracket assembly (6 screws). Be careful of gasket.
- (12) Mark the shutter position (for reference only) and remove shutter and, if necessary, the centrifugal device.
- (13) Remove the 4 screws holding the shutter shaft housing and withdraw same.
- (14) Remove the 2 screws in the holdback sprocket shaft bracket so that its gear will clear the main shaft. It might be preferable to remove the framing knob, move the stripper and remove the holdback sprocket so that the entire holdback shaft bracket assembly can be removed.
- (15) Remove the take-up drive shaft extension (1 screw).
- (16) Remove the screws in the 3 bearing hangers for the vertical shaft and lift the entire vertical shaft assembly from the gear case. Remove and discard the coil spring if it is found on the hex stop for the fork (lower bearing hanger).
- (17) Frame to both extreme positions in effort to drain as much oil as possible from the intermittent. Reset at normal center position. Wash out interior of housing with solvent and dry with lintless cloths.
- (18) When a new Cl 750 51-G1 shaft only is to be installed the pin holes for the shutter drive gear, the lower drive gear and the oil slinger must be drilled on the job. As an alternative the A9 500 18P assembly can be used. This consists of a shaft, 2 gears, oil slinger, with pre-drilled holes, a steel pinion and roll-pins.

The fork, intermittent drive gear and key should be assembled on the main shaft and checked for freely sliding action to both extremes.

Assemble the parts to be used with the bearings and hangers from the removed shaft.
- (19) Reinstall the new vertical shaft assembly and tighten screws.

When reinstalling the main vertical shaft see that the red index on the fork centers over the red mark in the casting so that in final assembly you can frame to both extremes with the intermediate fibre gear remaining well within the limits of the large sliding gear in the fork.
- (20) After this much reassembly check the clearance of the intermediate gear, relative to both the sliding gear and the intermittent gear.

If necessary, shift the intermediate gear bracket to provide minimum clearance without bottoming. One (1) screw for the idler bracket appears in the framing shaft bracket, film side, and the other 2 behind the lens holder. Tighten screws well.

Following the relocation of the Cl 750 15 idler bracket, the Cl 750 10 fork must be checked for freedom of movement by (1) framing to one extreme position, (2) framing to opposite extreme position, and (3) framing to mid-position (normal). In each position the fork should be lifted manually and observation made to see that it automatically falls back to its original position. If any binding is present the Cl 750 15 bracket must again be reset or one side of the bracket filed or machined slightly to increase clearance from the fork.

N O R E L C O

THEATRE SERVICE INSTRUCTION #23

- (21) Reinstall holdback shaft assembly. Check gear clearances on all 3 sprocket drive gears. If necessary remove dowel pins from bracket and realign for proper mesh. If the screws are well tightened new dowel pin holes need not be drilled.
- (22a) If the lower fibre gear on the new vertical shaft differs in the number of teeth as compared to the original gear then a matching steel pinion must be installed on the end of the horizontal driving shaft. A Cl 753 82 steel pinion (with 6 teeth) is part of the A9 500 18 kit and matches the Cl 754 60 Fibre gear (24 teeth) on the lower end of the shaft. (The earlier gear set consisted of a Cl 750 66 steel pinion (8 teeth) and a Cl 750 48 fibre gear (32 teeth) which are no longer manufactured).
- (22b) Reinstall the driving shaft bracket and check gear mesh. If necessary remove and discard dowel pins in flange of bracket and adjust the gear mesh. Install oil pump.
- (23) Reinstall shutter bracket, adjust gear mesh and tighten screws.
- (24) Mark center of shutter periphery by measurement. Reinstall shutter, leave 6 flat head screws slightly loose.
- (25) Complete reassembly of parts previously removed, fill oil reservoir to proper level and install gear case cover. Fill coupling of take-up extension shaft with grease and also apply some grease to lower pin in the shaft.
- (26) Thread a short piece of 70mm film in projector and inch down several frames with motor knob and check framing. When framing is correct inch down slowly in one direction until frame line appears in center of aperture, even with rib in rear of curved runner plate. Have inching knob held in this position. Shift shutter on its flange until center mark is in center of aperture - tighten screws enough to hold. Project a picture, preferably titles or target film. Observe for ghost from a position close to screen. Shift shutter slightly if necessary and tighten 6 screws well.
- (27) It will probably be necessary to shift the centrifugal device on the shutter shaft to a new position. With intermittent sprocket in threading position the straight edges of the shutter blade should be vertical and the blade 180° from the light path. The centrifugal device can then be reset so that its vertical edge is parallel with the vertical edge on the cooling plate lever. The clearance between the face of the lever and the face of the round portion of the centrifugal device is 1/32" to 1/16" maximum. This can be changed by shifting the position of both the round collar on the shutter shaft (1 screw) and the centrifugal device (2 screws). Clearance between the face of the round collar and the sliding member of the centrifugal device is about .005" (1 film thickness). Tighten 3 screws. Manually check for free sliding of centrifugal device without sticking.
- (28) Also check the position of the circular threading indicator after above adjustments. With the intermittent set for threading, the shutter edge at vertical and the cooling plate open, shift the threading indicator disc if necessary so that a white line coincides with the pointer.

FOR PROJECTORS EQUIPPED WITH ONE MOTOR

In general the same instructions apply but with the following changes:

- (6) Loosen hex nuts holding the motor and raise latter to top of slots. Tighten 1 nut.
- (7) Remove 2-speed clutch pulley (3 screws behind front cover plate).
- (8) Not applicable.

8-3-66 FJP
North American Philips Company, Inc.
Motion Picture Equipment Division
100 East 42nd Street
New York, N.Y. 10017

Norelco

**MOTION PICTURE
EQUIPMENT**

NORTH AMERICAN PHILIPS COMPANY, INC.
Motion Picture Equipment Division
299 Route 17, Paramus, N. J. 07652

THEATRE SERVICE INSTRUCTION #24

UNIVERSAL 70/35 and AAI PROJECTORS

Urgent attention is called to the instructions contained in the third section of TSI #19 - Issue 2, for periodically removing, cleaning and relubricating the take-up shaft extension in the base of the above projectors. In theatres not operating on a limited hourly basis, monthly performance of this procedure should be followed.

If the take-up drive assembly position has been disturbed or if it was improperly assembled at the time of installation, it may be necessary to shift this assembly to obtain proper alignment.

The following, taken from the original installation instructions, are repeated:

In the upper base remove the filister head screw that holds the slotted coupling at the top of the take-up drive. Slide the coupling down on the shaft. Partially fill the socket end of the take-up drive extension shaft (found in Case #3) with EL 4850 Ball Bearing grease (found in Case #8). Apply some grease to the pin end of the shaft. Insert the shaft into the bottom of the projector head, hollow head up, until it engages the bottom of the projector vertical shaft. Bring the pin end in line with the top of the take-up drive shaft, push the slotted coupling up to engage the pin, align the screw holes and re-insert the filister head screw. Tighten well. The take-up shaft extension should have slight end play and be movable up and down, by hand, quite freely. If not, loosen the 4 hex head bolts holding the take-up drive bracket and shift the bracket as required to align the take-up vertical shaft and the extension. Firmly re-tighten the 4 hex head bolts.

On later model projectors there will be found a white enameled round metal ring that serves to clamp the center of the lower magazine to the casting. Where this ring is found it should be temporarily removed before attempting to shift the take-up drive assembly.

Reinstall the white ring. Enlarge the clearance holes for the screws if necessary.

The above alignment procedure should only be followed after the projector head is aligned on and firmly fastened to the base as described at the bottom of page 4 and the top of page 5 of the Installation Instructions for the model AAI projector.

North American Philips Company, Inc.
Motion Picture Equipment Division
299 Route 17
Paramus, New Jersey 07652

11/15/68

THEATRE SERVICE INSTRUCTION #25

TODD - AO - UNIVERSAL 70/35 - AAI PROJECTORS

OIL PUMP AND MOTOR DRIVE SHAFT

See Figure 20 - Page 32 and Page 33 in the Parts Catalog and T. S. i #17.

Three versions of the horizontal drive shaft Ind. No. 1, Fig. 20 have been delivered. The differences between shafts were confined to the end at which the steel driving pinion was fastened. While the earliest version is now obsolete, all shafts were interchangeable when equipped with the proper drive pinion. The drawings below illustrate the pinion end of the horizontal shaft and bracket to aid in explaining the differences.

First Version

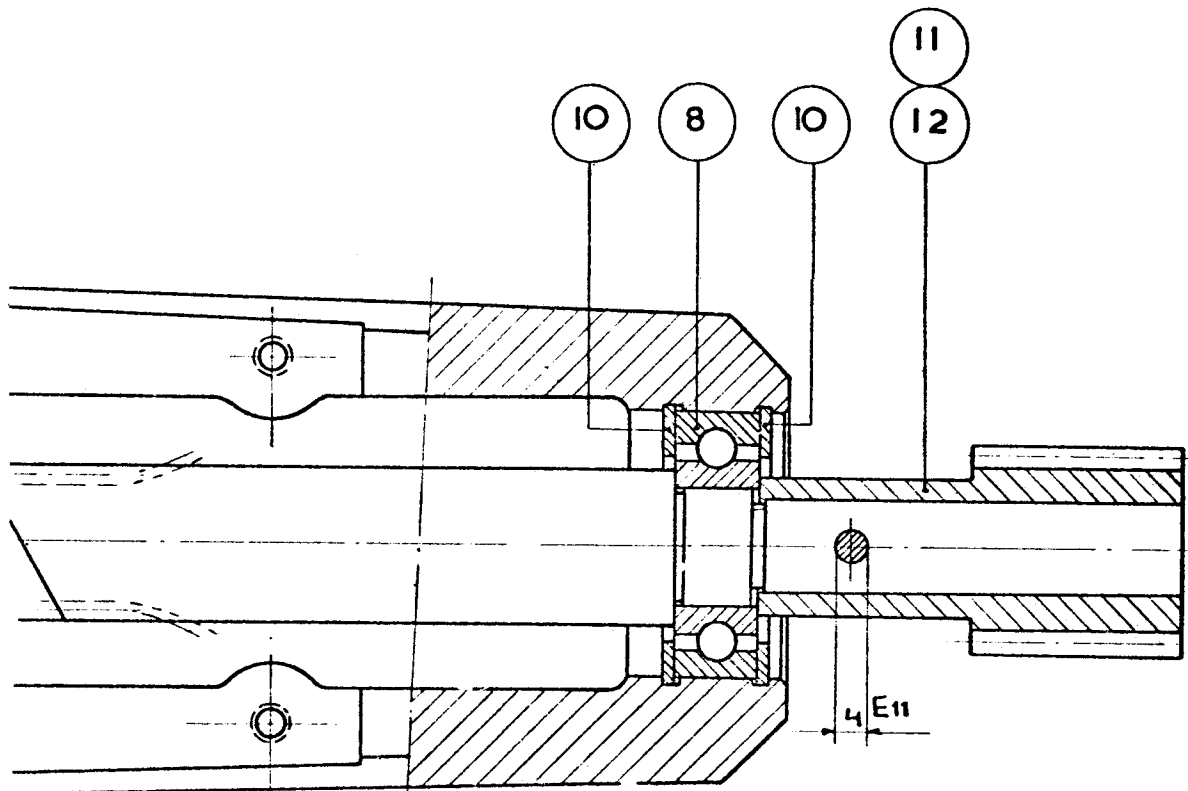

(1) The part indications and numbers given on pages 32-33 apply to this drawing.

(2) This shaft had an annular groove machined near the hub end of the pinion to allow the pinion to bear against the inner race of the ball bearing.

(3) The steel pinion was pinned to the shaft with a 4 mm O.D roll pin.

(4) The Cat. No. C175066 pinion had 8 teeth and mated with a 32-tooth fibre gear, Cat. No. C175048, which was pinned to the lower end of the vertical shaft in the projector.

(5) The above pinion and gear are now obsolete and have been replaced by the C1 75465 Gear Set (See T.S. 1 #17) which consists of

- 1 - C1 75382 Steel Pinion 6 - Teeth
- 1 - C1 75460 Fibre Gear 24 - Teeth

Second Version

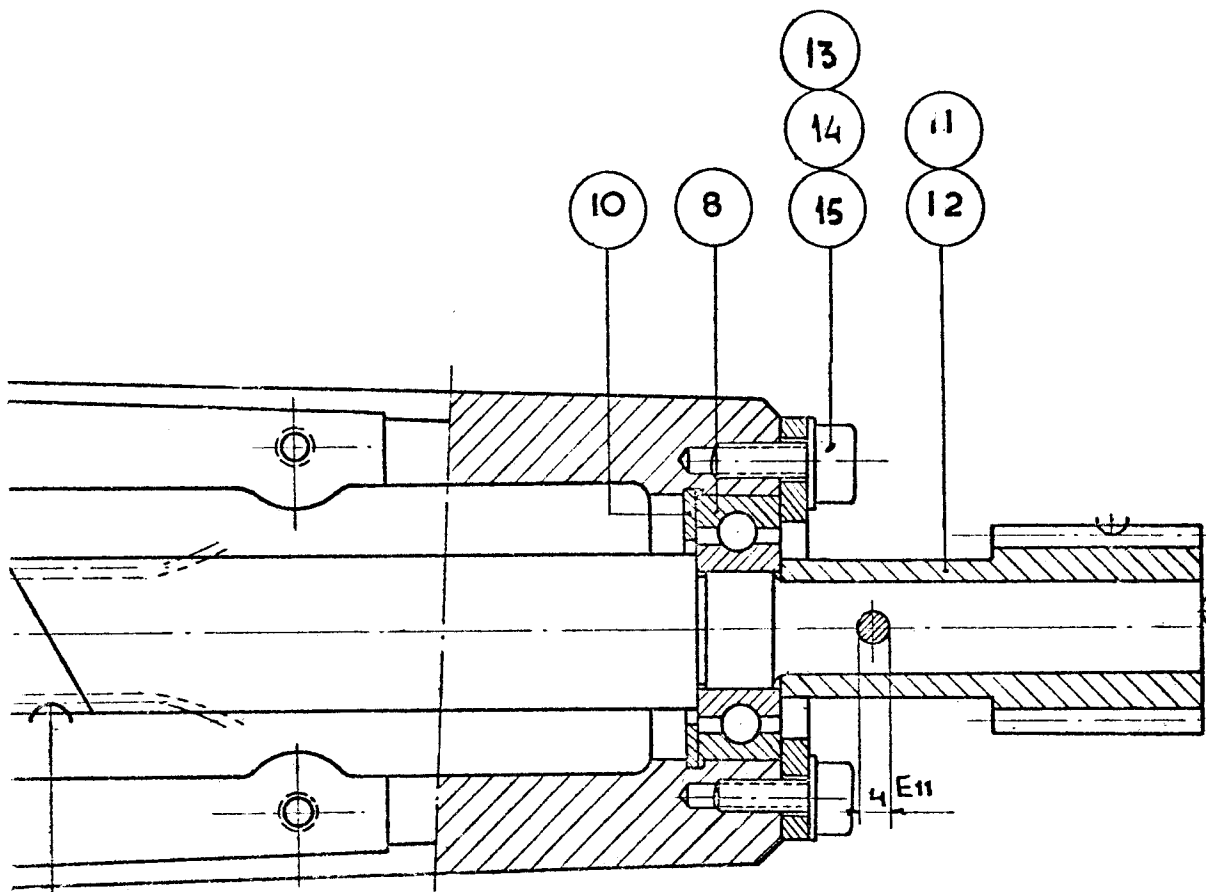

(1) The ball bearing 8 and the front retaining ring 10 are as shown on pages 32 - 33.

(2) The second (rear) retaining ring 10 has been replaced by a clamping ring with screws and washers 13 14 15 and the end of the bracket has been redesigned. This clamping ring assembly is not subject to wear.

(3) Instead of the annular groove on the shaft a fillet has been provided and the Bore in the hub end of the pinion has been relieved correspondingly.

(4) The pinion is a 6-tooth Cat. No. C1 75382 steel pinion - a part of the C1 75465 gear set (TSI #17)

(5) The pinion is pinned to the shaft with a 4mm O.D. roll pin.

(6) The shaft carried Cat. No. C1 750 64.1

Third Version

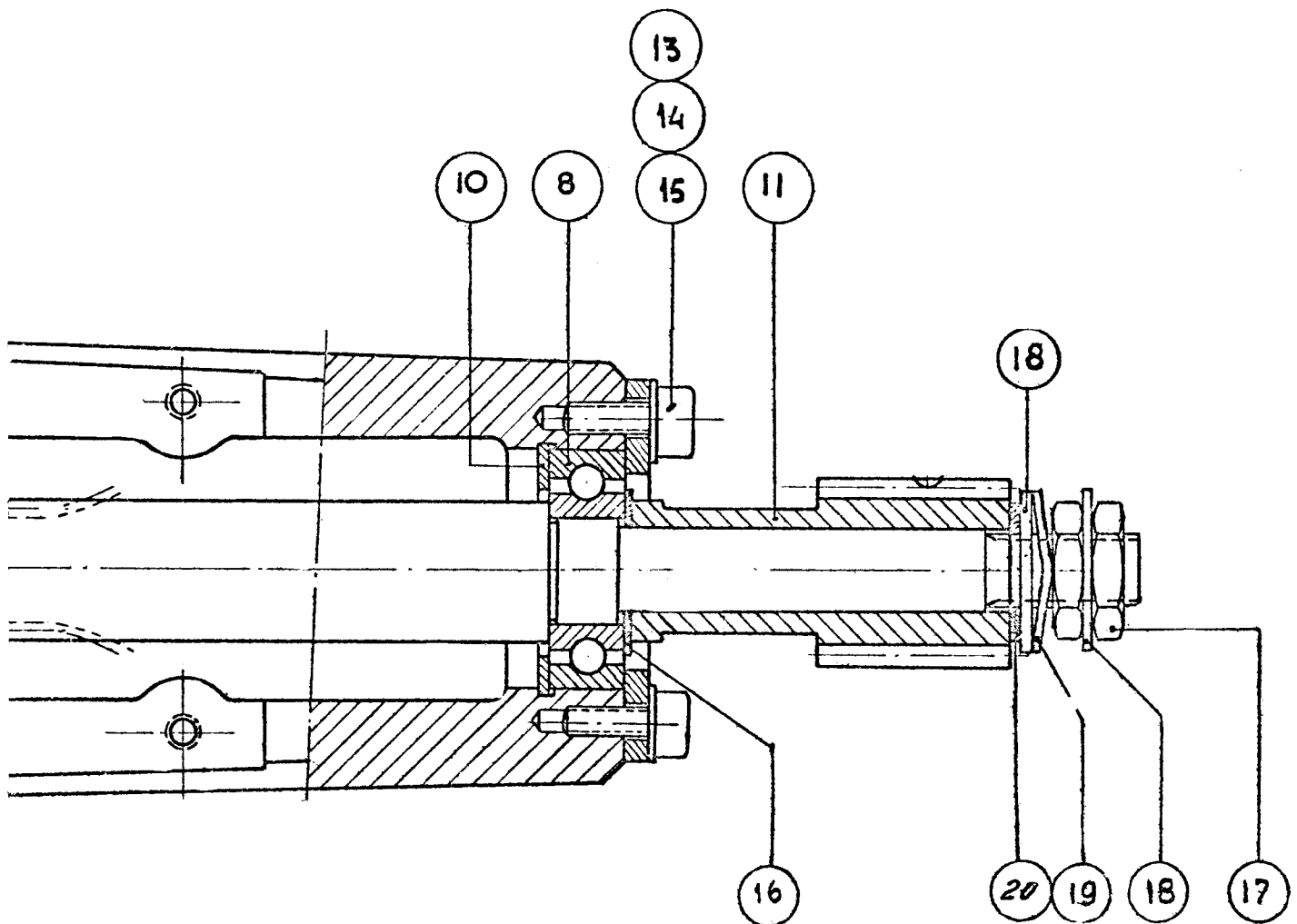

(1) The retaining ring, ball bearing, clamping ring and screws ⑩ ⑧ ⑬ ⑭ ⑮ as well as the drive bracket are the same as used on the second version.

(2) The horizontal drive shaft is changed to provide a slip-clutch arrangement at the pinion end.

(3) The 6 tooth steel pinion is not pinned to the shaft.

(4) Referring to the encircled numbers on the above drawing the part numbers are as follows:

⑪	C1 75382	6 T-steel pinion
	part of C1 75465 Gear Set	
⑫	C1 75610 (705 12507)	Bronze disc
		12 mm I.D.
⑬	22 415 50 (505 10428)	Hex. Steel Nuts
⑭	22 415 53	I.K. Steel Washers
⑮	22 415 51	Spring Washer
⑯	22 446 57	Bronze Washer
		10 mm LD

A C1 754 66 shaft assembly is available.

This assembly consists of items ⑫ ⑬ ⑭ ⑮ ⑯ and a C1 75064.2 horizontal drive shaft on which have been assembled Ind. No.s 2 thru 8 and Ind. #16 as shown on pages 32-33 of the Parts Catalog.

The C1 75382 Steel Pinion (6 teeth) is not a part of this assembly and if needed must be ordered separately as Cat. No. C1 754 65 gear set.

Theory

The third version was designed to provide protection against gear damage, because of overload, by the slipping action in the pinion-clutch assembly.

All projectors are run in for 50 hours minimum at the factory. At that time the clutch pressure is adjusting for the normal starting torque of a standard motor operating on nominal line voltage.

The drive motors on all Norelco 70/35 projectors have been of the synchronous type to provide an unvarying film speed of 90 Ft/Min as is required for best sound reproduction.

Synchronous motors while maintaining clock-like speed regulation are affected by high line voltage in that the starting torque rises sharply when the line voltage is above that of the nominal motor rating.

Field observations have shown that the power supplies in new theatres, where the electric service is modern, usually measures above 115 volts.

In such cases the protective clutch as described above may show evidence of slipping excessively during the start phase of the motor. This is often diagnosed as slow starting and the motor, belt drive etc. becomes suspect. After the motor has switched out of the start phase; via its internal centrifugal switch; and into run phase only the normal running torque of the motor is effective, the clutch slippage ceases, and the machine operates at normal speed.

Under some conditions the slow start, i.e. clutch slippage, is only experienced until the projector warms up for a short time.

The correction if needed is simple, quite quickly effected and probably best performed after an overnight shut down.

Adjustment

- (1) Remove gear case cover.
- (2) Referring to the last illustration above loosen the outer hex nut (17) sufficiently to slip a well fitting wrench between washers (19) and (18)
- (3) Tighten the inner hex nut (normal R.H. Thread) in increments of 1/3 to 1/2 a turn and test by switching on motor after each increment. Do not tighten more than needed to eliminate slippage during start phase. Do not run motor more than a few seconds each time to prevent false indications from warm-up and oil spattering.
- (4) When satisfactory adjustment is achieved tighten outer hex nut to lock adjustment.
- (5) Replace gear case cover.

1-2-69