

Film-Tech

The information contained in this Adobe Acrobat pdf file is provided at your own risk and good judgment.

These manuals are designed to facilitate the exchange of information related to cinema projection and film handling, with no warranties nor obligations from the authors, for qualified field service engineers.

If you are not a qualified technician, please make no adjustments to anything you may read about in these Adobe manual downloads.

www.film-tech.com



C/CC - H/HH - SA/DA.

PROJECTOR MECHANISMS

INSTRUCTIONS

STOLEN FROM
DON JARVIS

From - Four Seasons Cinemas
Post Office Box 4761
Rumford Branch
Providence, R. I. 02916

CENTURY PROJECTOR CORPORATION

NEW YORK 19, N. Y.

Century *The Modern Projector*

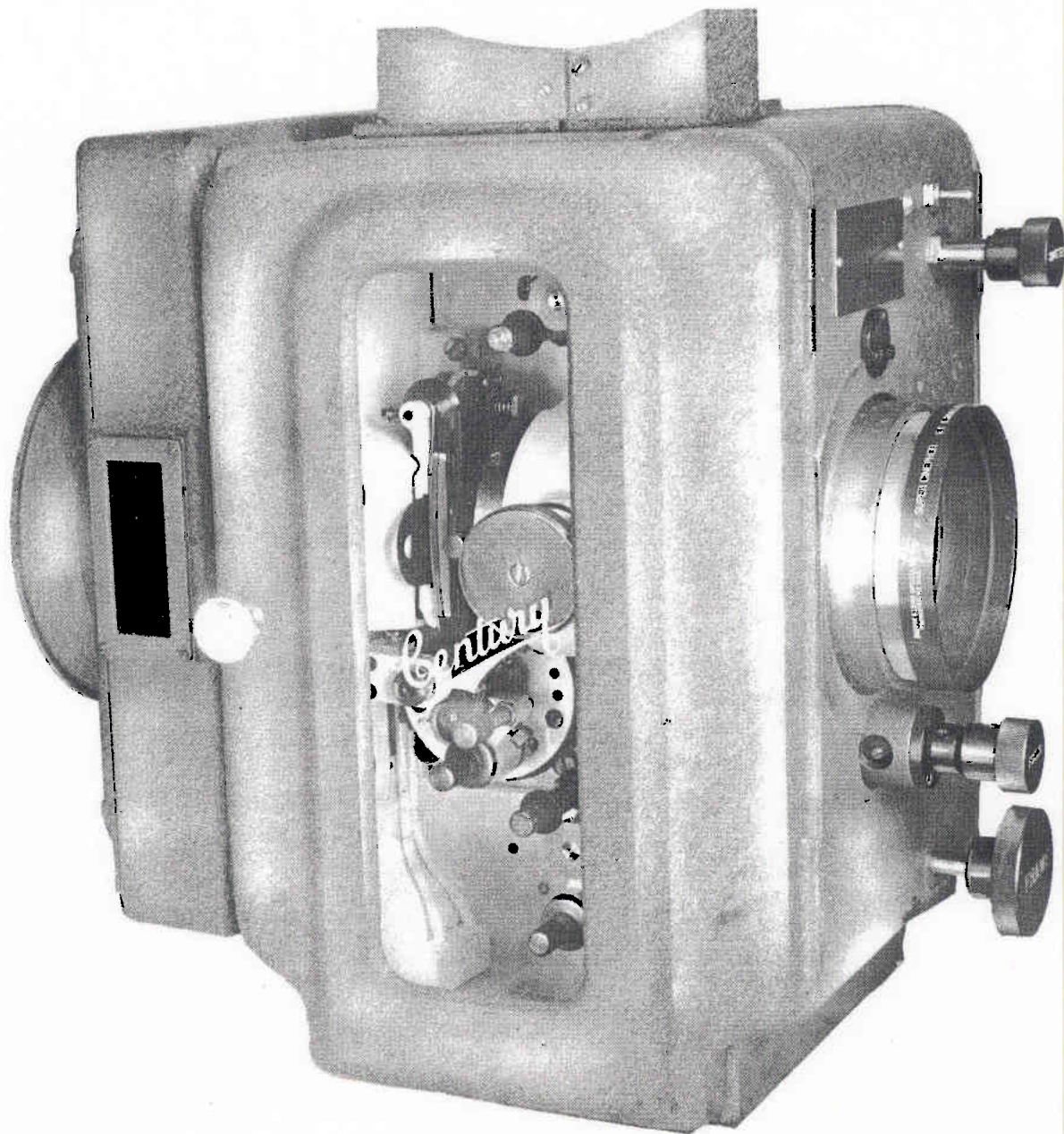

CENTURY PROJECTOR CORPORATION

729 SEVENTH AVENUE • NEW YORK, N. Y.

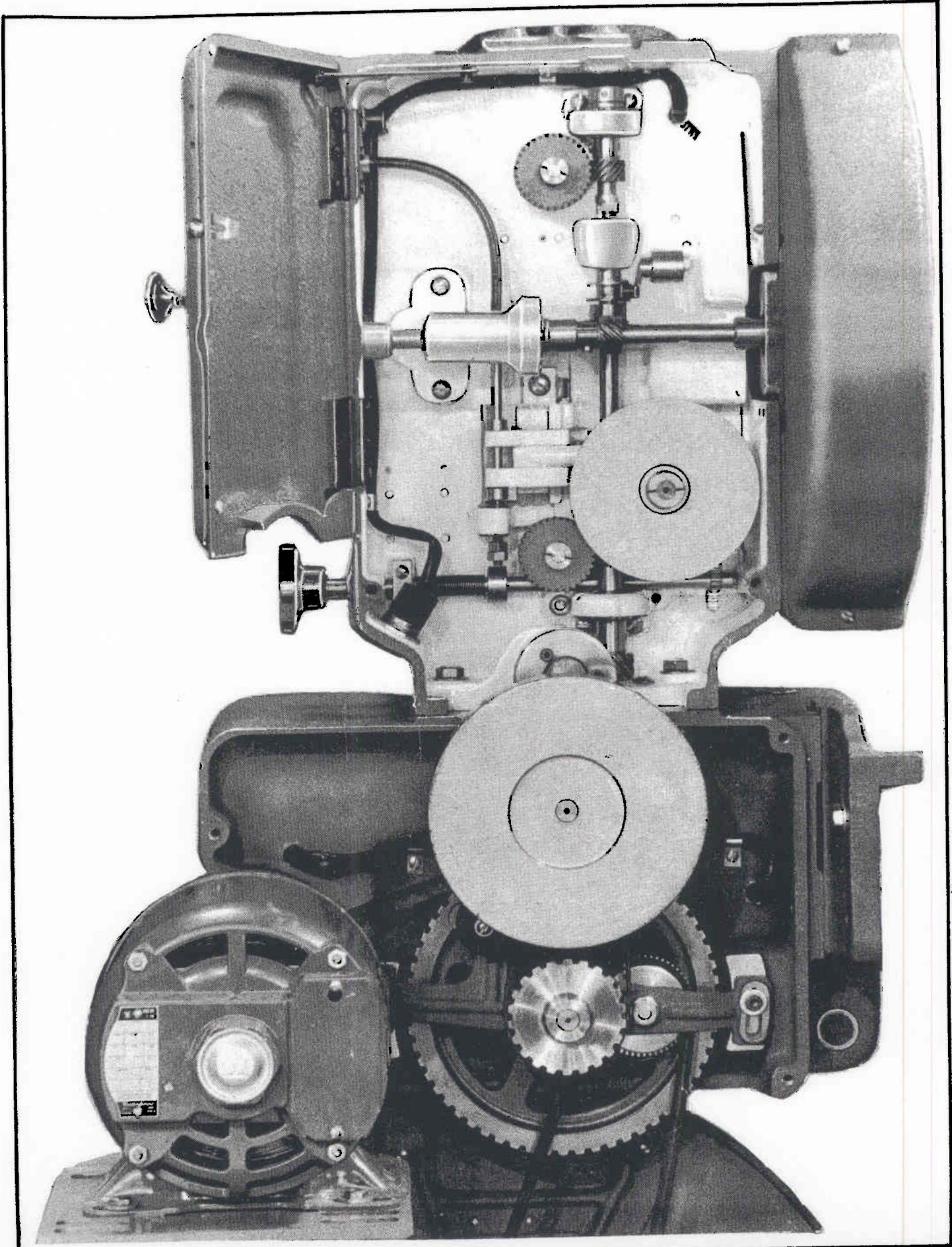

CENTURY PROJECTOR MECHANISM AND CENTURY SOUND REPRODUCER
SINGLE SHUTTER-DRIVE SIDE

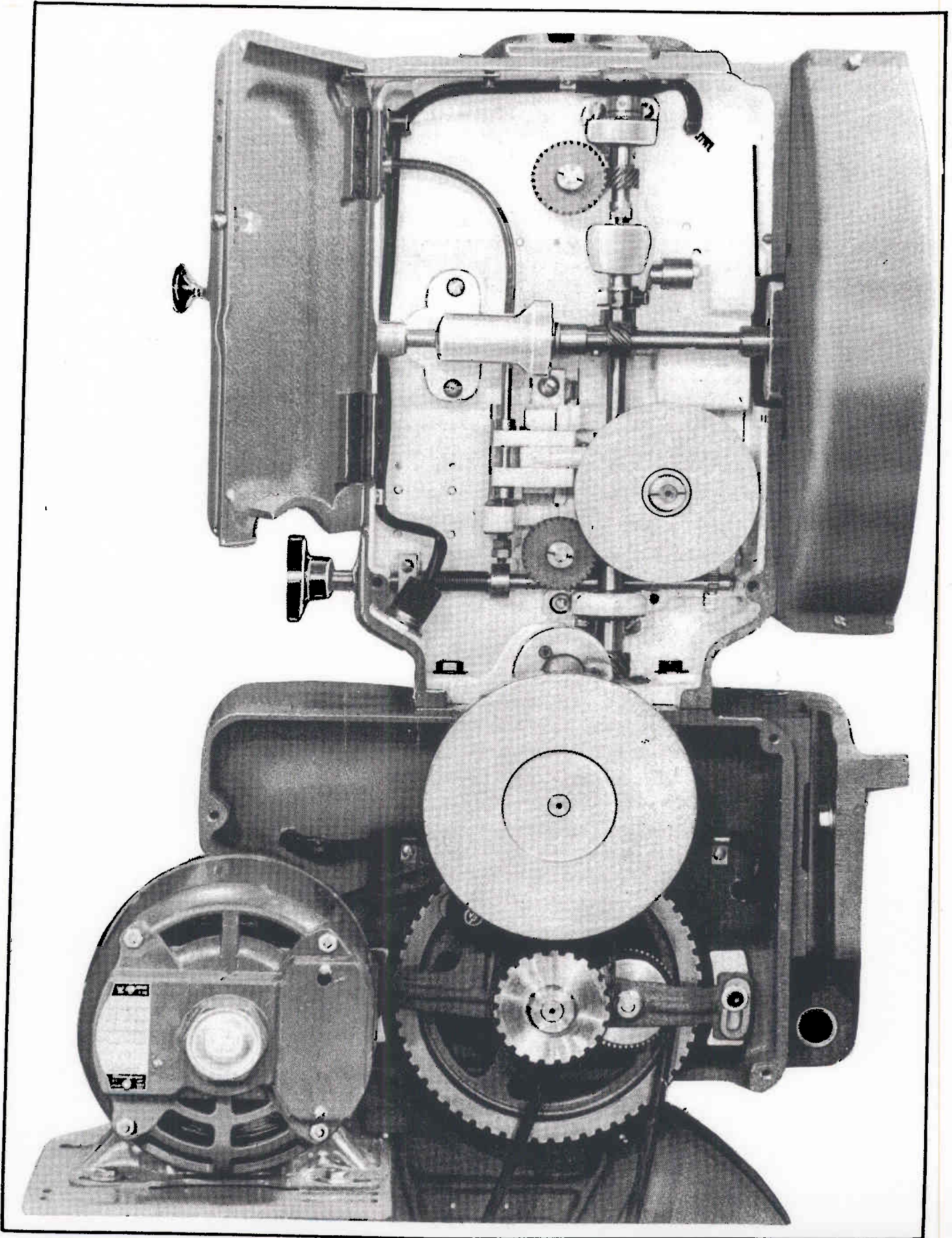

CENTURY PROJECTOR MECHANISM AND CENTURY SOUND REPRODUCER
SINGLE SHUTTER-DRIVE SIDE

**INSTALLATION — ASSEMBLY INSTRUCTIONS
CENTURY PROJECTOR MECHANISMS**

INDEX

<u>DESCRIPTION</u>	<u>PAGE NUMBER</u>
INSTALLATION	
Mounting The Projector.....	5
Projector And Sound Reproducer Coupling	5
OPERATION	
The Film Trap, Film Gate And Control Knob.....	6
Pad Rollers	6
Installing The Lens.....	7
Timing And Resetting The Shutters.....	7-8
Threading The Projector.....	8
Framing	8
LUBRICATION AND MAINTENANCE	9
ADJUSTMENT AND REPLACEMENT OF PARTS	
The Intermittent Movement.....	10-11
The Film Trap.....	11-12
The Film Trap Support-Retainer.....	12
The Film Trap Support-Water Cell.....	12
The Film Gate	13
The Film Gate Control Knob Assembly	13
The Lens Holder And Film Gate Support Assemblies	13-14
The Fire Shutter Assembly.....	14
The Framing Light	14
The Film Sprocket Shaft And Gear Assembly	14
The Pad Roller Arm Assemblies.....	14-15
The Vertical Shaft Assembly	15
The Main Drive Shaft Assembly.....	15
The Shutter Shaft Assembly	16
The Shutter Shaft -- Double Shutter Unit.....	16-17
INSTALLATION OF A REPLACEMENT INTERMITTENT MOVEMENT	18
ILLUSTRATION OF DOUBLE SHUTTER INTERMEDIATE GEAR BRACKET..	19

PRICE \$1.50

CENTURY PROJECTOR CORPORATION

729 SEVENTH AVE., NEW YORK, N. Y., U. S. A.

INSTALLATION

MOUNTING THE PROJECTOR

The height of the optical center above the mounting surface of the Sound Reproducer and the position of the picture aperture with respect to the mounting holes are "Standard" in the Century Mechanism and therefore it can replace other types of Mechanisms without requiring any changes in adjustments in existing Arc lamps and Sound Reproducers.

There are four additional mounting holes located in the Mechanism base besides the two tapped holes usually provided. These four mounting holes may be used for additional support of the Mechanism. Century Sound Reproducers are designed to make use of this special mounting feature in the Century Mechanism by having four holes to correspond to the four holes in the Mechanism Base. In installations of Century Mechanism and Century Sound Reproducer the four mounting bolts are inserted in the Mechanism and threaded downward into the Sound Reproducer. With other types of Sound Reproducers which require the use of the two mounting screw hole supports, the bolts are inserted in the Sound Reproducer and threaded upward into the Mechanism Base. For the RCA 9030/9050 Series Sound Reproducers an additional tapped hole has been incorporated in the Century Mechanism Base to utilize the three hole mounting provision of the RCA mounting plate. In installations of this type make sure mounting bolts are the proper length. A safety screw is provided in the Century Mechanism Base to stop a too long screw from going beyond that point and cause damage to the bottom gear on the Vertical Shaft in the Mechanism. Caution: Do Not Force Mounting Screws Beyond This Safety Point Nor Remove The Safety Screw In The Mechanism Base.

NOTE:

Care should be taken to properly align the Mechanism with the Sound Reproducer making certain the Projector Mechanism is mounted square with the Sound Reproducer and that the sprockets in the Reproducer and in the Mechanism are in exactly the same vertical plane. If units are not aligned accurately, film noise and possibly film damage may occur.

PROJECTOR AND SOUND REPRODUCER COUPLING

GENERAL

The Century Projector Mechanism is driven from the Sound Reproducer through the Main Drive Shaft Assembly. There are a number of types of these assemblies to take care of most makes and models of Sound Reproducers. Consult your Century parts catalogue for complete data.

Unless specified otherwise, Century Projector Mechanisms are furnished with the Standard Main Drive Shaft Assembly (C1-G-110) for use with standard Century and other Makes and Models of Sound Reproducers having alike Coupling Mounting provisions. Optional Equipment - The special Century main drive shaft assembly (M3-G-110) is provided in mechanisms specified for direct drive operation to Century Model M (Direct Drive) Sound Reproducers. Caution: M3-G-110 Main Drive Shaft Assembly used only for coupling to the special Century Direct Drive Sound Reproducers.

MOUNTING THE SOUND REPRODUCER COUPLING

The Sound Reproducer Drive Sprocket or Gear is mounted directly onto the main drive shaft hub with the mounting screws and washers provided with the sound reproducer drive parts. If the sound reproducer drive sprocket or gear has three mounting holes install on shaft hub using the corresponding holes of the hub to complete the assembly. The 17 tooth drive pinion and gear as used with other makes of Mechanisms are not needed with the Century Main Drive Shaft.

OPERATION

THE FILM TRAP: FILM GATE AND CONTROL KNOB:**GENERAL**

For reference to code numbers and additional description of the parts consult your Century Parts Catalogue.

FILM GATE CONTROL KNOB

The Large Knob Assembly (H1-A-66) on the Film Gate Support Bracket (A1-A-70) controls the opening and closing of the Film Gate. TO OPEN FILM GATE turn the knob to the right, TO CLOSE FILM GATE, press in knob with the palm of the hand allowing the gate to close properly for operating. The gate control knob device is designed to automatically lock the gate in its closed position. It cannot be opened except by turning the knob. In its open position the control knob will not release the Film Gate for operating except by pressing it in.

THE FILM GATE AND FILM TRAP

The Film Gate should be removed regularly and cleaned thoroughly. The Shoes and the Studio Guides on the Film Trap should be kept cleaned making sure all deposits of dirt and Film emulsion are removed. All dirt and other matter should be removed between the Film Trap Casting and the upper Lateral Guide Rollers so that the Rollers turn freely.

To remove the Film Gate with its fixed curved pad for cleaning, set the film gate in its open position and loosen holding screw (SC-144). - Pull the Film Gate toward the Film Trap disengaging the Gate Plate Studs from its support Tube and Bracket. To re-install the film gate reverse this procedure.

The pressure of the Film Trap spring shoes has been properly set at the factory and should be entirely satisfactory for running most all conditions of films. It is therefore suggested that no changes be made in the factory adjustment unless absolutely necessary. Should increased film tension be indicated turn the adjustment knob slowly at the top of the film trap, clockwise, until desired tension is obtained. It is good practice to operate with as little pressure as possible and as is consistent with the conditions of the films and for a steady, clearly focused picture. **THE LIGHTER THE PRESSURE THE LESS WEAR ON THE PADS, SPROCKETS, ETC.**

PAD ROLLERS

The upper and lower pad roller arms are opened by pushing the roller knobs toward the rear of the Mechanism. The pressure pads on the intermittent sprocket are opened by pushing the knob downward.

The upper and lower pad rollers in their open position provide for automatically setting the loops above and below the film gate. The lower pad roller also provides a means of measuring the correct distance of the film frame between the picture aperture and the sound aperture thus assuring exact synchronization of sound and picture.

Although there are no tension springs showing on the pad roller arms, each has a scientifically designed built-in device providing just the proper amount of pressure for optimum performance.

The upper and lower pad rollers should be adjusted so that there is a clearance of two thicknesses of film between the pad roller and the sprocket. The proper clearance is obtained by adjusting the stop screw and nut on the pad roller arms.

INSTALLING THE LENS

The lens mount is designed to take the modern four inch diameter lenses and with the proper adapters will permit the use of all types of lenses (no changes in the shutters are necessary).

In placing the lens in the lens mount care should be taken that the front of the lens is towards the screen, otherwise the quality of the picture will not be satisfactory.

The lens mount as shipped from the factory is set in its correct center position in relation to the picture aperture. If a small correction of picture centering with respect to the screen is indicated, loosen the small retaining nut at the top of the lens clamp casting and then turn the large centering bushing knurled knob in clockwise or counterclockwise direction until centering of the picture is obtained. Re-tighten nut securely. In many instances this centering feature will make it unnecessary to shift pedestal to attain picture centering.

The lens focusing knob should be turned so that the lens mount clamp is in the center of its full length of travel. Insert the lens into the lens mount and clamp the lens lightly in place with the lens clamp screw (SC-1229). If the focus is not good when the picture is projected, the lens may be shifted forward or backward until a fair focus is obtained. The lens clamp is then tightened and the final accurate focusing is made with the lens focus knob (KN-45) that extends outside, at the front of the Mechanism.

A lens focusing ring and stop stud are available to allow the lens to be removed and re-installed without the necessity of re-focusing. For extra long lenses and heavy anamorphic attachments there are available special front lens support assemblies.

TIMING AND RESETTING THE SHUTTERS

GENERAL

Each Century Projector Mechanism has been set up and run-in at the factory and therefore the shutters should be "in time". If shutters require retiming be sure before changing any setting that the shutters cannot be corrected by turning the shutter adjustment knob at the front of the Mechanism.

TO CHECK THE TIMING OF THE SHUTTERS

Remove the spot sight glass in the fixed shutter guard by pressing lightly inward and upward. NOTE: The indicator bar in shutter guard across the opening is used for timing the shutters. Turn the Mechanism until the slot in the intermittent flywheel is parallel with the shutter shaft at the same time the intermittent sprocket is in motion. The slot in the intermittent flywheel hub is parallel with the shutter shaft twice in each revolution: once when the cam and starwheel are locked and again when the sprocket is in motion.

The latter is the correct position for checking adjustments and corresponds to a two tooth advance of the intermittent sprocket. In this position the notch on the shutter blade (single shutter) should line up exactly with the indicator bar across the spot sight frame. In a Double Shutter Mechanism the notches of both blades should line up exactly with each other and with the indicator bar. If the notch does not line up as required try adjusting by means of the shutter adjusting knob (KN-43) at the front of the Mechanism. When adjustments are made by means of the knob, the intermittent flywheel must remain stationary. If proper adjustments cannot be attained by turning the adjusting knob then the shutter(s) will require re-setting.

TO RESET SHUTTERS

Set the shutter adjusting knob (KN-43) in its mid-position. Remove the rear shutter guard by taking out the four holding screws (2 at the rear - 2 on the gear side) Caution: make certain that the intermittent sprocket is advanced two teeth from its stationary position and remains there or that the slot in the intermittent flywheel hub is parallel with the shutter shaft as outlined in a previous paragraph. Loosen shutter hub clamp screws and rotate the shutter on the shaft until the notch lines up as required. In a Double Shutter Mechanism loosen hub screws of both shutters and rotate the shutters on the shaft until notches line up as required; Do not allow shafts to turn. Holding the intermittent flywheel while rotating the shutters will prevent shafts from turning. Tighten shutter hub clamp screws securely. Install shutter guard. Check notch alignment and replace spot sight glass. Shutter(s) should be now properly set and the shutter adjusting knob should not be turned unless absolutely necessary.

Note: This same procedure is used whether the double shutters are the straight edge or dissolving (DDS) type.

THREADING THE PROJECTOR

Open the gate, the upper and lower pad roller arms and the intermittent sprocket pad. Light the framing lamp by operating the switch on the front of the Projector Mechanism. Thread the film through the **roller holder in the upper magazine; under the upper sprocket; over the upper pad roller; through the gate; under the intermittent sprocket; around the lower pad roller; over the lower film sprocket and down to the sound reproducer.**

Place the film in the gate engaged with the intermittent sprocket and in-frame at the framing aperture above the picture aperture. Close the intermittent pad assembly and the film gate. Engage the film with the upper sprocket and close the upper pad roller arm. (The upper loop is correct as the pad roller in its open position acts as an automatic loop setter). Engage the film with the lower sprocket using the pad roller in its open position as a loop setter. Close the lower pad roller arm.

CAUTION: When running down film (frames) **DO NOT SWITCH PROJECTORS ON AND OFF** - is suggested turning mechanism, manually using shutter shaft knob at front of the mechanism provided for this purpose or using motor hand wheel/flywheel of the sound reproducer.

With film correctly threaded through the Sound Reproducer to the Lower Magazine the Projector is ready to operate.

FRAMING

The framing of the picture on the screen may be changed by turning the framing knob (KN-44) on the front of the Mechanism. The degree of clamping of the framing shaft may be changed by tightening or loosening the framing shaft clamp screw.

LUBRICATION AND MAINTENANCE

LUBRICATING THE PROJECTOR MECHANISM:

ONCE A MONTH - A few drops of oil or a little white Petroleum Jelly on all gear contacts. A few drops of oil in the oil cups of the upper and lower sprocket shafts.

CAUTION - DO NOT OIL BALL BEARINGS -- They are grease-sealed for the life of the Bearing. Do Not Oil Mechanism while it is in operation. Do Not Use Benzine or other harsh solutions on the shafts and gears where excess amounts might enter the Sealed Ball Bearings.

OILING THE INTERMITTENT MOVEMENT

Oiling is done through the oil cup on the intermittent arm, operating side. Fill with Century Certified Projector Oil to oil level of window. Do Not Fill over this oil level - surplus oil will overflow through the vent holes and possibly be forced out of the oil cup.

Check oil gauge window every so often (with the mechanism stopped) to be sure intermittent movement has sufficient oil. Once a month add a few drops of oil to the starwheel outer bushing.

TO DRAIN INTERMITTENT MOVEMENT OF OIL

Remove bottom "oil drain" screw with its steel, fibre and copper washers and drain out the oil. Place a clean cloth beneath this screw hole to catch the oil and prevent it from running down into the Sound Reproducer. Replace the oil drain screw making sure the steel, fibre and copper washers are placed in that order on the screw. (Fill intermittent to oil level with fresh Century Certified Projector Oil.)

Caution: Do not add oil to the intermittent while the projector is in operation. The intermittent cam acts as a splash distributor supplying fresh oil constantly to the cam, starwheel and bushings. Therefore, there may be no indication of an oil level showing on the window while the Projector is operating.

MAINTENANCE

Other than keeping the intermittent Movement properly supplied with oil and the Projector Mechanism clean, the maintenance of your Century Mechanism should be minimum.

It is good mechanical practice to periodically check your equipment to be sure holding screws, fastening screws, nuts, collars etc., are tight and have not worked themselves loose. This is particularly applicable to parts installed in the field as drive couplings, adapter parts and mounting screws.

Keep lateral guide rollers and fire rollers clean, free of dirt, accumulations and film shavings to be sure they are rotating properly on their studs and in their housings.

Film Care - Green (new) films and some treated films with or without magnetic tracks may have a tendency "to stick" to the film trap and gate shoes of a projector for the first few runs or until they become "conditioned". There may also be some shedding or flaking of the iron oxide from the magnetic tracks which might settle on sprocket teeth, intermittent movement arm, etc.

It is therefore suggested that all films be edge-waxed or lubricated by one of the several known processes.

A POLICY OF CONTINUOUS PREVENTIVE MAINTENANCE BY KEEPING ALL FILM RUNNERS, SPROCKETS, AND PADS CLEAN AND FREE OF ANY FOREIGN MATTER PLUS HAVING ALL PRINTS LUBRICATED WILL RESULT IN BETTER PROJECTION.

ADJUSTMENT AND REPLACEMENT OF PARTS

GENERAL

The modern unit construction principle is used throughout the Century Projector Mechanism to facilitate maintenance and servicing.

The Century Mechanism consists of unit assemblies as: The Intermittent Movement with intermittent sprocket pad - the main drive shaft - the vertical shaft - the shutter shaft - the film trap - the film trap support-retainer - the film gate - the film sprocket shafts - the pad roller arms - the lens mount and focus - the gate control device and support, etc.

The operating assemblies and components are easily removed and most adjustments and replacements can be accomplished in the booth by qualified personnel. Most of the units are located by Dowel pins to make replacements easily and accurately. If after many years of service, a factory reconditioning of the complete Mechanism or of the intermittent movement is desired, arrangements for this work should be made through the local Authorized Century Distributor.

The Century Intermittent Movement is manufactured with utmost precision. The star and cam are expertly matched, shafts are hand-fitted in their bushings and the complete unit assembled and adjusted by specially trained factory personnel. It is therefore extremely difficult to make major adjustments on this unit in the field. It is therefore recommended that the overhauling of the Intermittent Movement be performed in the Century Factory where the tools, gauges and complete facilities are available for precision work. Only general information on the Intermittent Movement for minor repairs is provided in section, "THE INTERMITTENT MOVEMENT"

THE INTERMITTENT MOVEMENT

To remove the Intermittent Movement from the Mechanism - Slip off flywheel from cam shaft by taking out flywheel fastening screw. On the operating side - Remove the light shield by loosening its two holding screws - Close the lower pad roller arm - Frame the intermittent carriage all the way in its downward position - Open film gate and remove it from the Mechanism by loosening its retaining screw (SC-144) - Loosen the four screws holding the Intermittent Movement in its carriage - Turn Intermittent Movement about an eighth turn in clockwise direction until cut-outs in the intermittent cover are even with the holding screws - Pull the Intermittent Movement straight out of its carriage, taking care not to hit the intermittent sprocket against anything which could damage its teeth. NOTE: If a replacement or emergency Intermittent is to be installed in the Mechanism, follow instructions under, INSTALLATION OF A REPLACEMENT INTERMITTENT MOVEMENT.

To replace the Intermittent Sprocket - Remove the Intermittent Movement from the Mechanism as described in the previous paragraph - Rotate cam shaft and gear until sprocket is in its locked position - Remove the film stripper - Take out the sprocket clamp screw and nut - Loosen the two screws in the end collar of the starwheel shaft and pull off the collar - Take out the two retaining screws that holds the starwheel shaft outer bushing and bracket and pull the unit straight off the starwheel shaft. CAUTION: This bracket is located by two dowel pins and if bracket does not slide off freely, tap gently on the inner side of the bracket taking care not to bend the starwheel shaft. Pull sprocket carefully off its starwheel shaft.

THE INTERMITTENT MOVEMENT

To install the Intermittent Sprocket on the Movement - Push new sprocket on the starwheel shaft carefully without force until screw hole in the sprocket lines up with the hole in the starwheel shaft - Insert screw and add on nut (DO NOT TIGHTEN NUT) - Place the starwheel shaft outer bushing and bracket on its intermittent cover - Replace the two retaining screws, tightening them securely - Turn the sprocket clamp nut up on its screw against the sprocket hub allowing two sides of the hexogon to seat in the cut-outs on the sprocket hub, thus anchoring the nut while the screw is being tightened - Re-install the collar on the starwheel shaft, pulling sprocket toward starwheel outer bushing and pushing the collar gently against the outer face of the bushing removing all end play - Tighten the two collar set screws securely - Replace the film stripper - Turn the intermittent movement by hand to make sure it is free and that the starwheel shaft is not binding - Re-install intermittent movement in the Mechanism reversing the procedure under, "To Remove the Intermittent Movement from the Mechanism".

CAUTION: When replacing flywheel on the cam shaft make sure flywheel fastening screw is tightened securely and that the flywheel is mounted solidly on the cam shaft.

To adjust end play of the cam shaft - Remove the large plug screw in the center of the intermittent cover which will expose the end of the thrust bearing. A screw driver slot is provided in the end of this bearing so that it may be tightened or loosened. It should be adjusted so that there is no perceptible end play in the cam shaft and yet not tight enough to cause the cam shaft to drag.

To remove the intermittent sprocket pad assembly - Loosen the set screw (SC-155) holding the complete assembly on the intermittent cover - Rotate the pad assembly to clear the intermittent sprocket teeth and pull the assembly out of its position.

To re-install the intermittent sprocket pad assembly on the intermittent - Push the arm into its mounting hole, making sure the pads are in their open position - Rotate the assembly until the detent in the pad stud bushing is in line with the assembly holding set screw - Tighten the holding screw securely. This setting automatically assures the proper position of the pads against the intermittent sprocket. An adjusting nut is provided to attain the proper pressure of the pads against the film.

THE FILM TRAP (ALL "A" MODELS)

To remove the film trap from the mechanism - Open film gate. Turn the large knurled thumb screw in the front of the film trap counter-clockwise until it is disengaged from the film trap support-retainer. In a water-cooled mechanism the water cell acts also as the film trap support-retainer. It is not necessary to remove thumb screw from support-retainer - Loosen screw only. Slide film trap straight out. NOTE: The film trap is removable from the mechanism without dismantling the film trap support-retainer from the main frame. To replace the film trap shoes - Turn the film trap shoe tension knob to its minimum tension position (white indicator line on knob "UP"). Take out the four shoe fastening screws (2 on top - 2 on the bottom) and remove shoes (studio guides need not be removed). Replace the two shoes on the film trap and fasten properly. To re-mount the film trap in the mechanism - Engage the dove-tail of the film trap with the dove-tail of the support-retainer sliding the film trap all the way in carefully until the machined surfaces of both the film trap and support-retainer are firmly against each other. Tighten the knurled thumb screw securely.

To properly re-align the film trap guides and lateral guide rollers - Remove the film gate and light shield - Loosen the pivots holding the upper lateral guide roller assembly and the screws holding the studio guides - Place Century C1-E-30 (Tool 32) gauge on the intermittent sprocket and push it over until the side plate touches the outside rim of the sprocket - Carefully push the gauge plate between the studio guides until it lays flat against the film trap shoes - Bring the upper fixed guide roller into contact with the outer side of the gauge - Lock both guide roller pivots. Adjust the studio guides into contact with the outer sides of the gauge thus allowing the proper clearance for the passage of the film. Tighten the studio guides fastening screws - Remove the gauge - Replace the film gate and the light shield in the Mechanism. Frame the intermittent to its center position.

To remove aperture plate from film trap - Pull aperture plate straight out dis-engaging it from its two retaining springs - A stop pin is provided on the film trap to assure that the aperture plate is accurately in position at all times. All Model "A" Mechanisms employ the PE-518 series aperture plates.

THE FILM TRAP SUPPORT-RETAINER (STANDARD)

To remove film trap support-retainer and asbestos plate - Open film gate and remove it from the mechanism. Remove film trap from mechanism by sliding it off support-retainer - Remove light shield (casting) by loosening the two holding screws. Take out the three film trap support-retainer fastening screws. Pull support-retainer straight out. To re-install support-retainer in mechanism - Install the film trap support-retainer in mechanism by engaging the locating slot in the support-retainer with the two dowel pins on the main frame. Replace the three support-retainer fastening screws (DO NOT TIGHTEN) - Move support-retainer backward or forward until the fastening screws are approximately in center of the counterbored holes in the support-retainer - Tighten the three support-retainer fastening screws securely. Replace the light shield, the film trap and film gate in the mechanism.

THE FILM TRAP SUPPORT-WATER CELL

To remove the film trap support-water cell - Open and remove film gate. Remove film trap and light shield. Remove intermittent movement. Take out the three trap support-water cell fastening screws and disengage the water tube connecting block at the bottom of the mechanism by removing its retaining screw. Pull water cell straight out of the mechanism. To re-install the film trap support-water cell in the mechanism - Install the film trap support-water cell on the mechanism frame engaging the locating slot of the water cell with the two dowel pins on the main frame. Replace the three film trap support-water cell fastening screws (DO NOT TIGHTEN). Insert water tube connecting block in position at the bottom of mechanism and fasten it with its retaining screw. Move film trap support-water cell backward or forward until the three fastening screws are approximately in center of the counterbored holes in the water cell. Now tighten the three screws securely. Re-install the intermittent movement, light shield, film gate and film trap.

FOR FULL EFFICIENCY AND TROUBLE FREE PERFORMANCE OF THE WATER CELL IT IS RECOMMENDED THAT THE CENTURY WATER RECIRCULATOR WITH A RUST INHIBITOR IN THE WATER SUPPLY BE USED IN THESE INSTALLATIONS.

THE FILM GATE

To replace the solid curved Film Gate Pad - Remove the film gate from the Mechanism, loosening its holding screw (SC-144). Remove the film gate pad by taking out the two holding screws. Install the new film gate pad with the stamping "Top" corresponding to "Top" on the film gate plate.

THE FILM GATE CONTROL KNOB ASSEMBLY

To replace Gate Knob Pressure Spring - (It is not necessary to remove knob assembly from film gate support bracket in the mechanism). Remove the screw in the center of the Knob - Pull the knob off - Remove old spring - Insert new spring with one end of the spring engaged in the hole at the bottom of the recess of the gate knob holder - Make sure gate knob shaft Pin (small part) is seated in the detent (open position) in the holder - Hold the knob over the end of the shaft so that the slot in the knob is at 90 degree angle to the key of the shaft - Engage the end of the spring in the nearest pin hole in the knob - Place the knob on the shaft and rotate the knob one-quarter turn clockwise until the slot in the knob and the key on the shaft line-up with each other. Push the knob firmly in place on the shaft - Replace and tighten the screw in the center of the knob - Grasp the gate control knob holder with one hand and the knob with the other hand and turn the knob one full turn to the right re-engaging the lock in the "open" position. This applies the correct operating tension to the spring. If less spring tension is desired proceed as above except when engaging the knob with the spring hold the slot in the knob parallel to the key on the shaft, thus engaging the slot and the key without turning the knob at that stage.

To remove the complete Knob Assembly from the Mechanism - Loosen the two set screws (SC-131); one above and one below knob assembly on the gate support bracket - Pull the gate knob assembly straight out.

To install the Gate Control Knob Assembly in the Mechanism - Make sure the gate control knob is locked in its hub and that the film gate is in its "Gate Open" position. Insert the gate control knob assembly into position on the film gate support bracket with the "oil hole" up so that the gate support tube and the recesses in the knob holder hub coincide with the holding set screws - Tighten the two holding set screws; above and below the knob assembly.

THE LENS HOLDER AND FILM GATE SUPPORT ASSEMBLIES

To remove the Lens Clamp and Support Bracket Assembly from the Mechanism - IT IS NECESSARY TO FIRST DISMOUNT THE FILM GATE SUPPORT BRACKET ASSEMBLY (A1-A-70). Take out the Lens - Open the film gate - Remove the four screws holding the gate support bracket and carefully dismount this unit from the Mechanism frame - Remove the upper lens clamp locating stud and disc by taking out its three retaining screws on the front of the Mechanism - Pull stud and disc straight out - Take out the four screws holding the lens clamp and support bracket and dismount the complete Assembly (H1-A-60) from the Mechanism frame.

To check and line up the Film Gate with its Supports } Place the film gate, the gate support tube and bracket assembly on a straight surface and check film gate pad to be sure it is parallel with the mounting surface of the support bracket. If adjustment is necessary, loosen the set screw (Allen) at the back mounting surface of the support bracket that holds the eccentric - Turn the eccentric either clockwise or counter clockwise direction until gate pad is parallel as required - Tighten the eccentric holding screw securely.

To install the Lens Clamp and Support Bracket Assembly in the Mechanism (Front Part) - Reverse the procedure as outlined under, to remove the lens clamp and support bracket assembly.

To install the Film Gate, Supports and Bracket in the Mechanism (A1-A-70) - Mount the complete unit in the mechanism with its four holding screws - **DO NOT TIGHTEN THESE SCREWS.** Re-mount the film gate assembly in position on the A1-A-70. Close the film gate and check spacing between top of the film trap studio guides and film gate plate. There should be a spacing of approximately 1/4 inch. To attain this, loosen the four holding screws of the gate support bracket and move bracket forward or backward until the proper distance between the gate plate and the studio guides is obtained making sure that the film gate is parallel with the top of the studio guides. Tighten the four film gate support bracket holding screws securely.

THE FIRE SHUTTER ASSEMBLY:

To re-set the height of the Fire Shutter - Loosen the fastening (set) screw in the upper governor weight holder on the vertical shaft which will allow the governor to be raised or lowered and will also raise or lower the fire shutter. The height of the fire shutter should be adjusted so that it does not come into the light beam while the projector is operating and yet not too high as to touch the top of the light shield. When the proper height is obtained, tighten the upper governor weight fastening (set) screw securely.

THE FRAMING LIGHT ASSEMBLY:

To replace the Framing Bulb - Unscrew the protector shield and remove bulb from its socket - Use a 7 watt - C-7 Clear Candelabra Base Lamp.

THE FILM SPROCKET, SHAFT AND GEAR ASSEMBLY (UPPER AND LOWER)

To remove Film Sprockets - Open pad roller arm - Take out retaining screw in the center of the sprocket and pull sprocket off the shaft - To replace Sprockets - Hold the sprocket shaft driven gear (formica) firmly against its bearing and place the sprocket on the shaft tightly against its bearing, removing all end play - Replace the film sprocket fastening screw and tighten it securely.

THE PAD ROLLER ARM ASSEMBLIES (UPPER AND LOWER)

To remove the Pad Roller Arms - Loosen the retaining screw by inserting the screw driver through the hole provided on the front of the Mechanism.

To remove the Pad Rollers - Loosen the retaining screw holding the pad roller shaft and knob and pull out the shaft and roller. To replace the Pad Roller - Place the pad roller on its shaft and install on the arm, making sure the shaft is adjusted properly to allow the roller to turn freely and to have a little side to side play - Tighten the pad roller shaft retaining screw securely.

To remove and replace the Pad Roller Arm Springs and Balls - Drive out the taper pin from the arm stud bushing and take off bushing - Pull the stud and knob straight out of the arm and remove the springs and balls - Install the springs and the balls in position in the arm - Replace the stud and the knob in the arm and add on the bushing on the stud - Press the stud and knob firmly against the arm and align the bushing with its tapered hole properly on the stud - Insert the bushing taper pin securely.

To install the Pad Roller Arm - Insert the pad roller arm in its bearing on the main frame of the Mechanism - Set the arm in its "closed" position against the film sprocket - Loosen the pad roller adjusting nut and back out the adjusting screw so that it does not make contact with its arm stop - Rotate the arm until the pad roller is in firm contact with the sprocket - Tighten the pad roller arm retaining screw securely - Tighten down the pad roller adjusting screw until it makes contact with the arm stop - Place two thicknesses of film between the sprocket and the pad roller - Reset the pad roller adjusting screw so that the pad roller holds the film lightly in place - Lock the adjusting screw by tightening its lock nut.

THE VERTICAL SHAFT ASSEMBLY:

To remove the Vertical Shaft Assembly from the Mechanism - Remove the shutter shaft assembly and the intermittent movement in accordance with instructions in this booklet - Take out the holding screws in the upper and lower ball bearing brackets (C1-G-31) - Remove the two screws (socket-head) holding the intermittent drive gear bracket in the shutter adjustment bracket and release the drive gear bracket from its position. NOTE: The upper and lower ball bearing brackets are located by Dowel pins on the Mechanism Frame. Take hold of the vertical shaft assembly with both hands disengaging the upper and lower bearing bracket from the dowel pins and remove the complete unit.

To disassemble the Vertical Shaft Assembly - Remove the collar (nut) on the top of the vertical shaft by loosening its two set screws and unscrewing it from the shaft - Remove the bottom steel gear (GR-4) from the shaft taking out its retaining screw. NOTE: In a direct drive mechanism the bottom steel gear on the vertical shaft is coded GR-182. All other parts on the shaft can now be removed - CAUTION: On re-assembling the vertical shaft make sure all washers are placed in their proper position - Steel washers are always placed against the faces of the ball bearings. All gears, collars and governor screws are tightened securely - The upper collar (nut) should be threaded down on the shaft gently against the washer retainer taking out all end play between the ball bearing bracket and the collar.

To install the Vertical Shaft Assembly in the Mechanism - Reverse the procedure under (To Remove Vertical Shaft Assembly From The Mechanism). CAUTION: Before tightening all mounting screws, mesh gears with minimum backlash - free of drag.

THE MAIN DRIVE SHAFT ASSEMBLY:

To remove the Main Drive Shaft and Gear from the Mechanism - Disengage the Sound Reproducer coupling from the mechanism - Remove the two set screws in the main drive formica gear (GR-8). NOTE: In a direct drive mechanism the main drive gear is coded GR-183. Pull the main drive shaft straight out which will also free the main drive gear from the Mechanism. CAUTION: Be sure that the two steel washers are removed from the Mechanism.

To install the Main Shaft Assembly in the Mechanism - Remove the ball bearing retainer beneath the lower sprocket arm by loosening its holding screw - The holding screw is accessible by inserting the screw driver through the hole at the front of the Mechanism, operating side. The ball bearing retainer has a small threaded hole in its center for inserting a screw (8-32x1") to allow pulling the retainer straight out of the Mechanism - Take out the ball bearing.

From the drive side of the Mechanism - Insert the main drive shaft through the ball bearing - Place on the main drive shaft - one steel washer and main drive gear (hub inward) - Push the main drive shaft all the way in and place the main drive gear in its proper position on the shaft, aligning the two gear screw holes with two flats on the shaft - Replace the two set screw in the gear, tightening them securely. From the operating side of the Mechanism - Place a steel washer and a ball bearing on the main drive shaft - Push the ball bearing all the way in and replace the retainer - CAUTION: Remove all end play in the assembly by seating the retainer firmly against the ball bearing - Tighten the retainer holding screw - Re-engage the Sound Reproducer coupling with the main drive shaft.

THE SHUTTER SHAFT ASSEMBLY:

To remove the Shutter Shaft Assembly from the Mechanism - Take off the shutter guard by removing the four holding screws (two on the rear - two on the drive side) - Slip off the shutter indicator knob from the front of the shaft by loosening its fastening screw - Take out the four screws holding the rear ball bearing bracket of the shutter shaft - Remove the two screws holding the front ball bearing bracket of the shutter shaft - The brackets are located by dowel pins - Take hold of the shutter shaft assembly with both hands, slide the rear ball bearing bracket and shaft to the right to clear the rear dowel pin - To clear the shutter adjusting flexible shaft, the front bearing bracket may be slipped forward on the shaft - Remove the complete assembly including the shutter(s) from the Mechanism.

To disassemble the Shutter Shaft Assembly (Single Shutter) - Slide off the shutter blade and hub by loosening the two hub holding screws. Remove the shutter spacer spring - the rear ball bearing and bracket and rear thrust collar. Remove shutter drive gear by taking out its fastening screw. Remove spring retainer, spring, washers and front ball bearing and bracket. The front indicator knob is removed by properly loosening its fastening screw.

To re-assemble the Shutter Shaft (Single Shutter) - Replace the rear thrust collar in position on the shaft, tightening the set screw securely. Mount the rear ball bearing and bracket on the shaft. Install the shutter spacer spring in the first groove on the rear of the shaft. On the front of the shaft install the shutter drive gear (hub to the front) in position and tighten its fastening screw. Place on the shaft (front) - the thrust spring retainer - the thrust spring - the washer retainer - neoprene washer - steel washer. Slide the front ball bearing and bracket on the shaft. Replace the indicator knob on the front of the shaft, fastening its set screw securely. Install the shutter blade and hub in position on the shaft and tighten the two hub screws securely.

To install the Shutter Shaft Assembly in the Mechanism - Reverse the procedure in Section, "To Remove The Shutter Shaft Assembly From The Mechanism". The two mounting screws for the front ball bearing bracket are tightened first. Before tightening the four mounting screws of the rear ball bearing bracket, adjust the gear mesh between the shutter shaft driven gear and shutter drive gear on the Vertical shaft. Gear mesh should be adjusted to provide just enough backlash without drag. In a double Shutter Mechanism the gear mesh should be adjusted properly between the shutter drive and the driven gears and between the intermediate shutter shaft drive and the driven gears. Before returning the Mechanism to service - Check to be sure all screws are tightened securely and the shutters are in-time.

THE SHUTTER SHAFT ASSEMBLY (DOUBLE SHUTTER UNIT)

To disassemble the Shutter Shaft Unit of a Double Shutter Mechanism - Remove the complete shutter shaft assembly in accordance with instructions in Section, To Remove Shutter Shaft Assembly From The Mechanism. Remove the outer shutter blade by loosening the two hub holding screws - Pull off the shutter spacer spring - Remove the inner shutter blade by loosening its hub screws - Remove the intermediate shutter shaft unit from the direct shutter shaft assembly by taking out the four screws holding it to the rear ball bearing bracket. This will release the rear ball bearing bracket, the reverse steel gear, the washers and the collar from the intermediate shutter bracket. To replace the matched pair of ball bearings in the rear bracket remove the collar on the reverse gear by loosening the two set screws in the collar - Slide the reverse gear out of its bearings - The rear pair of ball bearings can be removed by taking out its four retaining screws. The direct shutter shaft ball bearing in the intermediate bracket can be removed by loosening its three retaining screws. The intermediate shutter shaft can be removed from its bracket by taking out the screw in the reverse formica drive gear and the screw in the thrust spring collar - The intermediate shaft front ball bearing can be removed by taking out its two retaining screws.

THE DOUBLE SHUTTER SHAFT ASSEMBLY (CONTINUED)

To Re-assemble the Double Shutter Shaft Unit - REFER TO ILLUSTRATION #2 ON PAGE 19 - Insert the direct shutter ball bearing (2) in the upper section of the intermediate bracket - Tighten the three cone pointed retaining screws securely.

Partially assemble the intermediate shaft (3) by placing the following parts on the front section of the shaft against the shutter gear (11); The small ball bearing (4) - one steel washer - the thrust spring (6) and the collar (5). Fasten collar to the shaft with its screw. Place one fibre and two steel washers on the shaft. Insert the small ball bearing (7) in position in the intermediate bracket (8). Install the assembled shaft through ball bearing (7) placing the formica gear (9) in position on the shaft with the hub of the gear toward the front. Fasten the shaft assembly in the bracket by replacing the two ball bearing retaining screws (17) - Fasten the formica gear to the shaft with its screw (10). Insert the pair of ball bearings (12) in the rear ball bearing bracket (13) with spacer between bearings.

NOTE: Double Shutter Mechanisms now in production utilize two separate ball bearing (12). Prior models employed a pair of matched ball bearings with the unshielded faces of the ball bearings adjacent - in this design arrangement extreme care must be taken that these matched bearings are kept absolutely clean. They should not be separated except under conditions which guarantees against dirt or dust, entering the open surfaces and into the grease.

Place on the sleeve of the steel gear (14) one steel washer. Insert the gear sleeve through the ball bearing from the machined face of the bracket. Now place one steel washer on the gear sleeve. Replace the collar (15) on the gear sleeve snugly against the washer taking up all end play - Tighten the two pointed set screws in the collar securely. NOTE: The gear sleeve has a groove to accept the collar set screw points so as not to mar the surface of the gear sleeve.

To Mount the Rear Ball Bearing Bracket onto the Intermediate Bracket - The closed side of the intermediate bracket (#1) is the upper side and the dowel pin hole of the rear ball bearing bracket is the upper end. With these references, bring both brackets together engaging the gears (9 and 14) carefully - Fasten the two brackets together lightly with the four holding screws (16). There is a slight clearance between the engaging sections of the two brackets and in the counterbored holes for the fastening screws - Utilize these clearances to obtain close mesh between the two gears (9 and 14) setting them for smooth running with a minimum of backlash. When correct gear mesh is obtained, tighten the four screws (16) securely. Slide the direct shutter shaft with the front ball bearing bracket into position into the rear bracket unit - Replace the shutter blades and the shutter spacer spring in position on the shutter shaft.

The complete shutter shaft assembly should be installed in the Mechanism in accordance with instructions in Section, TO INSTALL THE SHUTTER SHAFT ASSEMBLY IN THE MECHANISM.

To lubricate the reverse Double Shutter gears - Add a little Century Gear-Lubricant with the finger tips from the bottom "open side" of the double shutter intermediate bracket where one of these gears (9) is exposed.

INSTALLATION OF A REPLACEMENT INTERMITTENT MOVEMENT

GENERAL

The installation of a New Replacement or Emergency Intermittent Movement in the Mechanism should be made in accordance with instructions on this page.

To install a Replacement Intermittent Movement in the Mechanism - Remove the regular Mechanism Intermittent as instructed in this booklet under, "To Remove the Intermittent Movement from the Mechanism".

Set the shutter adjustment knob at the front of the Mechanism mid-way of its full travel - Remove the Spot Sight Glass in the Shutter Guard - Rotate the Mechanism by hand until the notch in the shutter Blade is even with the bottom of the spot sight aperture. In a Double Shutter Mechanism the notch of the outer blade should be even with the bottom of the spot sight aperture.

Remove the flywheel of the replacement movement by taking out its fastening screw - Refer to Illustration #1 on page 19 - Loosen the Intermittent Stop Screw (A) Hold the Intermittent Movement and rotate the gear on the flywheel cam shaft until the sprocket advances exactly two teeth. Be careful not to move the gear from this position.

Install the Replacement Intermittent Movement in the Mechanism with cut outs (B) Matching the locking screws (C) and the bottom of the film trap shoes (D). Turn the Intermittent Movement slowly counter clockwise until the Intermittent Cam Gear (2) meshes with its driving gear (1) on the Vertical shaft. Continue to turn Movement until the gear mesh is adjusted with no backlash or play. Tighten any two opposite screws (C) - push the stop plate (E) tight against stop (F) and tighten screw (A). Loosen the two screws (C) which were previously tightened and turn the movement clockwise until there is a space of $3/64$ " (.046) between stop plate (E) and its stop (F). Hold the Intermittent in this position or insert a $3/64$ " spacer (or a dime) (G) between stop plate (E) and its stop (F). Tighten all four screws.

Loosen screw (A) and remove the $3/64$ " spacer (G), if used. Push stop plate (E) tight against its stop (F). Tighten screw (A). Replace and fasten the flywheel on the cam shaft. A slight amount of backlash should be present between gears, (1) and (2).

Oil Movement through Oil Cup (M) until oil level in window (O) is reached. Always check oil level before running. Place a small quantity of white petroleum jelly on gears, (1) and (2).

The notch (K) in the shutter blade should now line up with the indicator bar (L) and the flywheel screw (H) should be in line with Vertical Shaft. Replace the Spot Sight Glass in the Shutter Guard.

If shutters require re-timing follow instructions as outlined in other sections of this booklet.

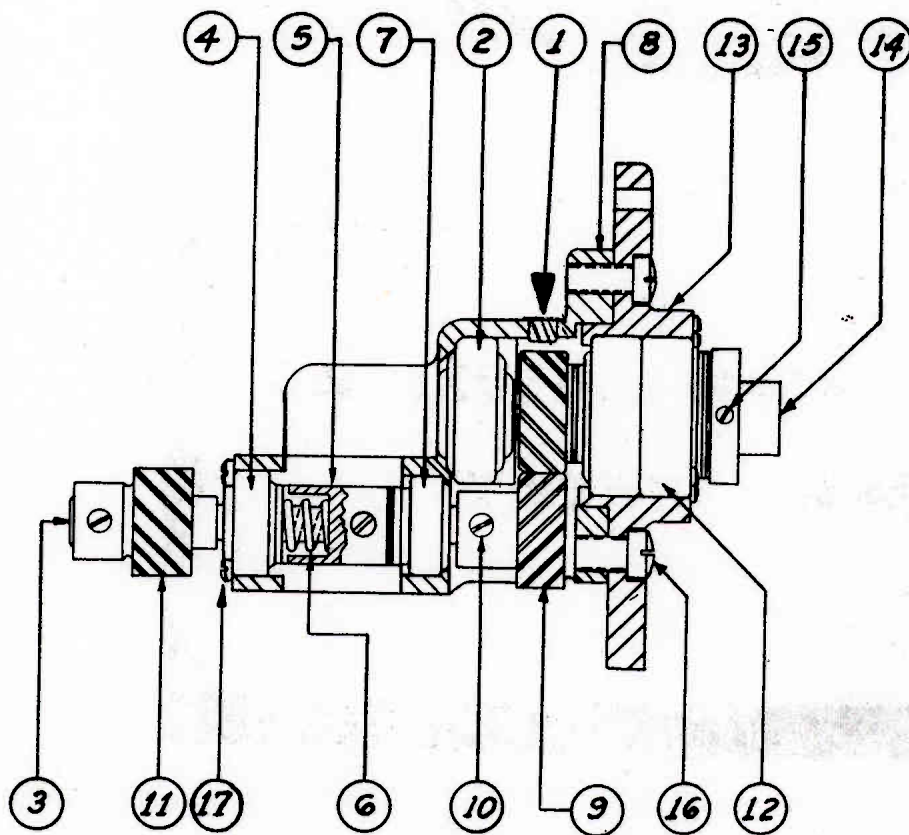
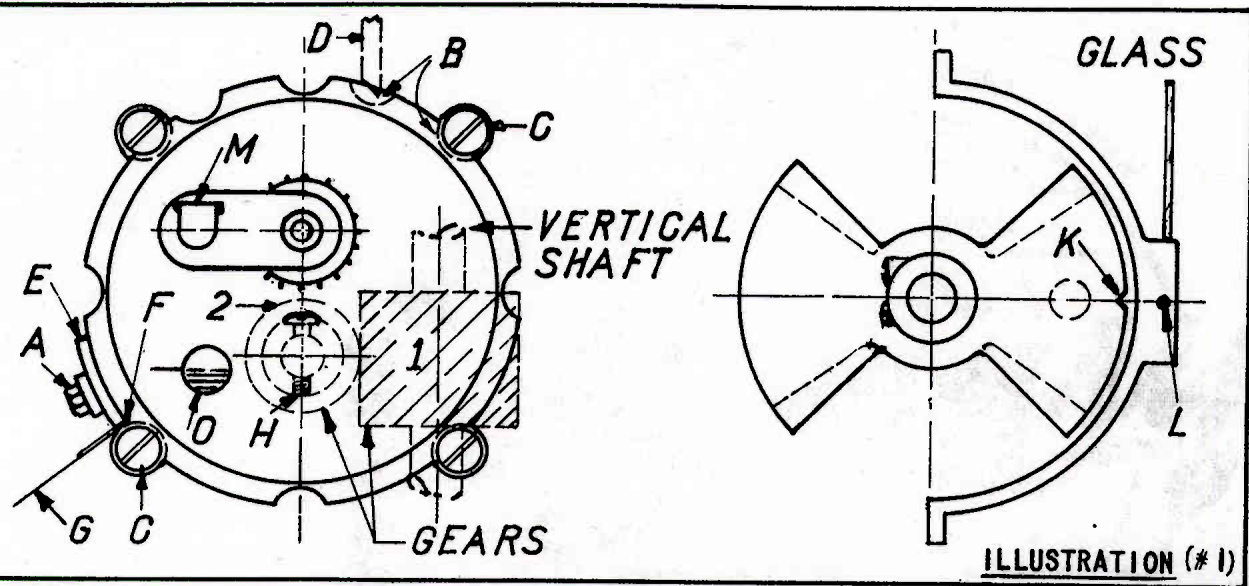

DOUBLE SHUTTER INTERMEDIATE GEAR BRACKET

ILLUSTRATION (#2)



**PROJECTOR MECHANISMS
INSTRUCTIONS**

CENTURY PROJECTOR CORPORATION

NEW YORK 19, N. Y.