

Film-Tech

The information contained in this Adobe Acrobat pdf file is provided at your own risk and good judgment.

These manuals are designed to facilitate the exchange of information related to cinema projection and film handling, with no warranties nor obligations from the authors, for qualified field service engineers.

If you are not a qualified technician, please make no adjustments to anything you may read about in these Adobe manual downloads.

www.film-tech.com



INSTALLATION OF REVERSE SCAN/DIGITAL READERS WITH RED LED

Take off the optical reader shaft code 0035 replacing it with the new one code D08322.

Mount this new shaft aligning the film paths with the intermittent sprocket. We suggest to use:

- the tool code A833 as a disalignment in the film path causes a film damaging
- the wrenches code 5551.18 and 5551.19 to tighten the reader shaft ring nuts (see page 18).
- After having removed the external drum, mount on the shaft the template code D07097 and, exploiting the play between the “G” screws and the respective holes, turn the bracket until the “E” upper diode gets as near as possible the template tip.
- Verify also the position of the “F” lower diode (analogue reader). It must be as near as possible the template tip when turned in the lower position.

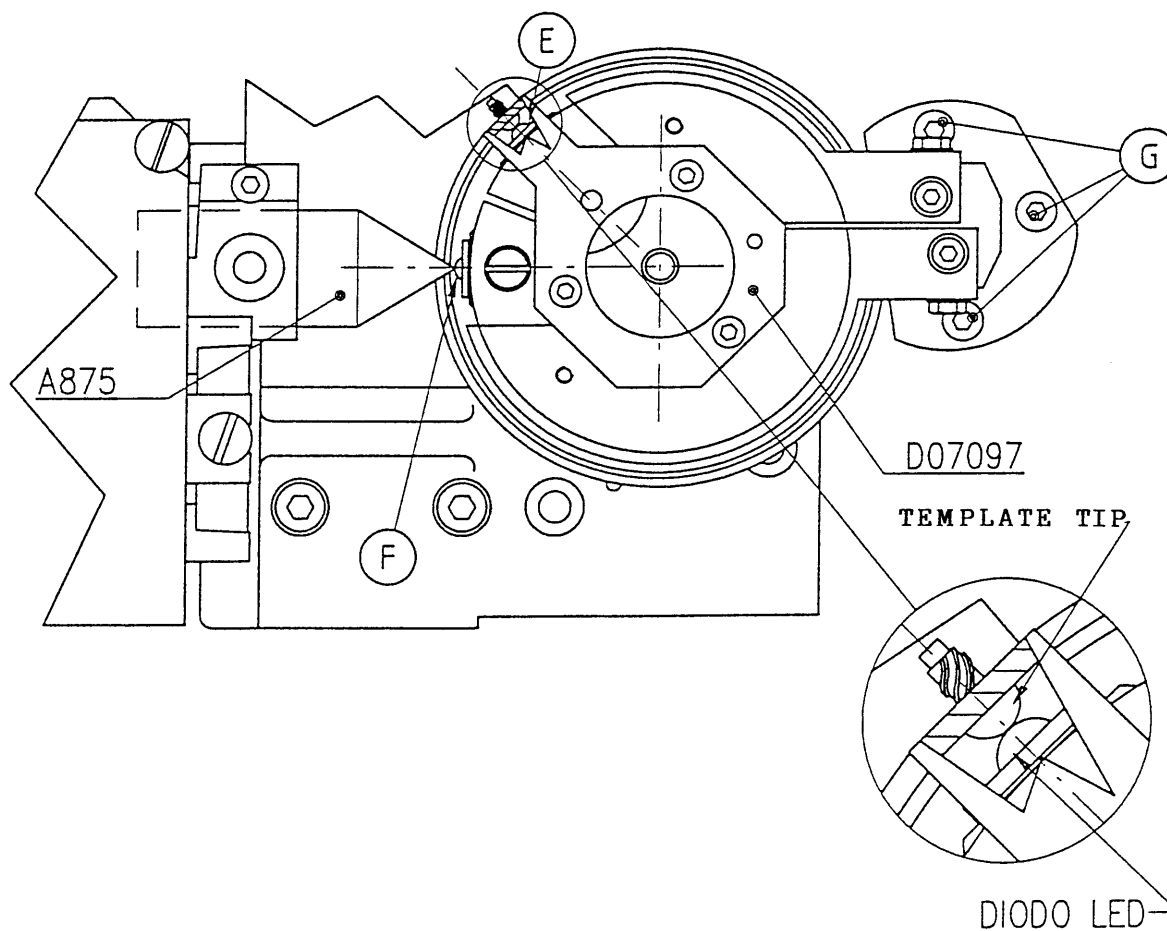

- Verify the alignment of the “F” diode with the sound lens assembly, mounting on the tool A875 in place of the sound lens of the reader, paying attention that the tool tip is aligned with the diode.
- After this, tighten the “G” screws.
- Set the “Q” cam at the central position, loosening before the “R” nut and the “P” screw, leaving this latter brake.
- Check that the diode support “E” is parallel to the front face of the “L” ring. If not, loosen the “H” grub screw and rotate by a screwdriver the support until obtaining the parallelism wished. Then tighten the “H” grub screw.

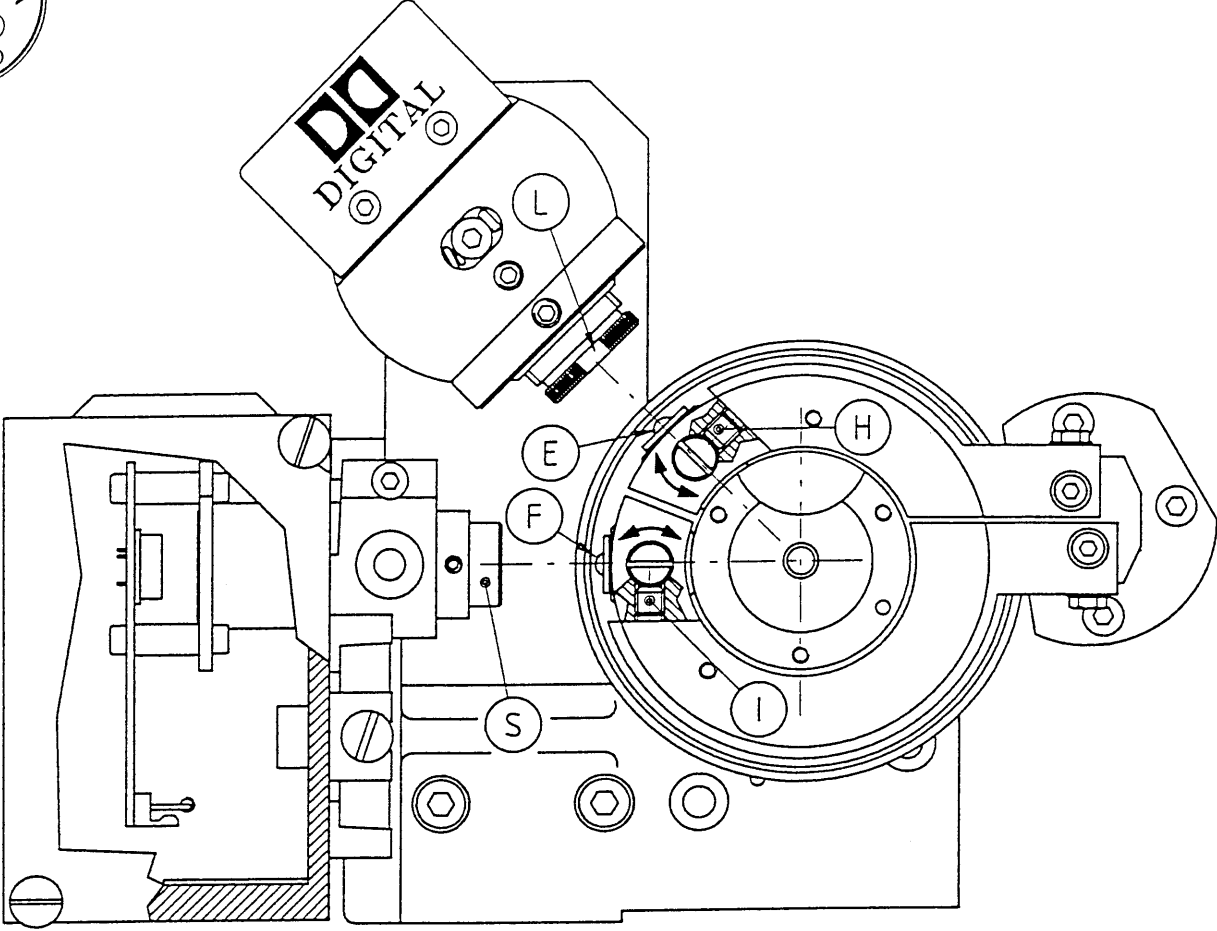

- Repeat this operation with the "F" diode which must be parallel to the frontal lens of "S", loosening the "I" grub screw and rotating the support until obtaining the parallelism desired. Tighten the "I" grub screw.

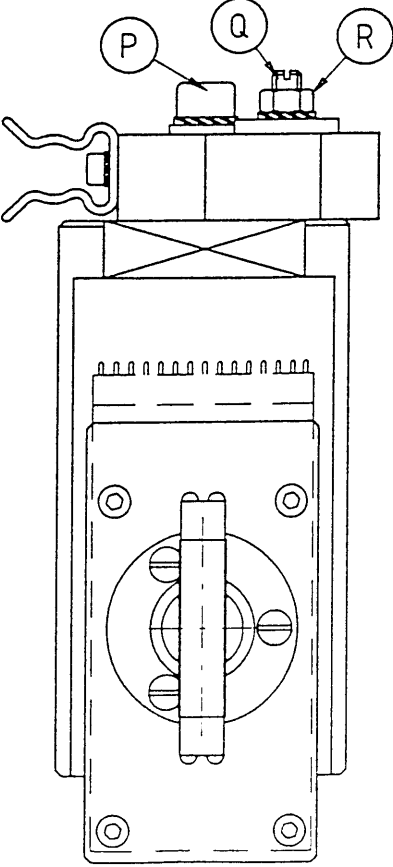

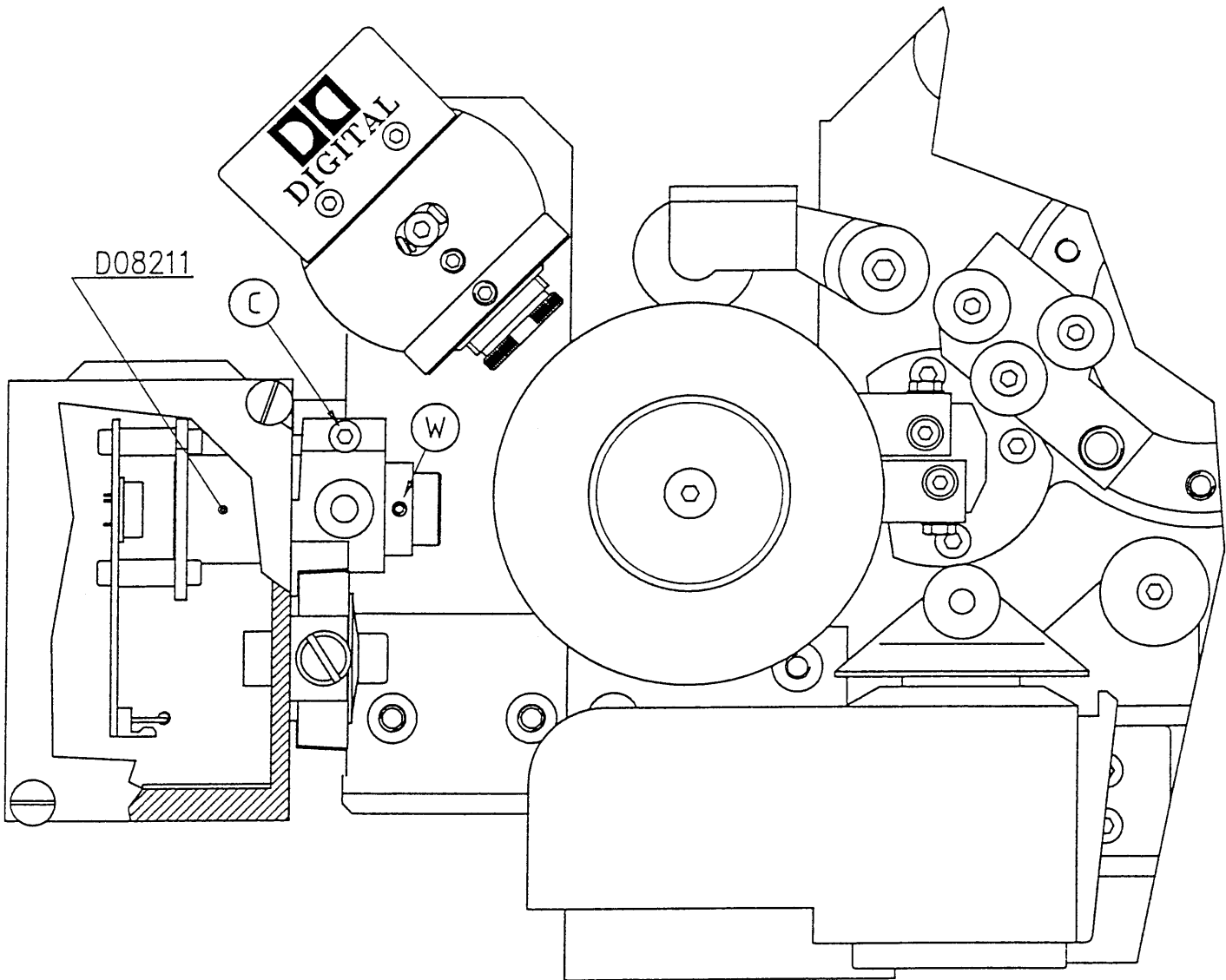

- Remount the external bell, paying attention, in case you have more than one projector, to fit it on the original shaft.
- Insert the analogue reader assembly D08211 in place of the sound lens, removing the small “W” grub screw that locks the lens.
- Remount the “W” screw and rotate the lens in order to have the slot present on the body turned up, so that the grub screw does not prevent the axial movement necessary for focusing.

N.B: before fitting completely the D08211 assembly, connect the power and the signal cables, otherwise it should be more difficult to connect them.

- Lock the assembly by the “C” screw.

Now you can set the digital reader and then the analogue one.



DIGITAL READER SETTING

Power the LED and set the trimmer placed behind the power supply in a position between 350mA and 400mA.

The power supplies output cable is not polarized as the supplier of the diodes does not assure the negative polarity on the diode case. If the diode does not light the plug. The diode will be not damaged by an inverted power.

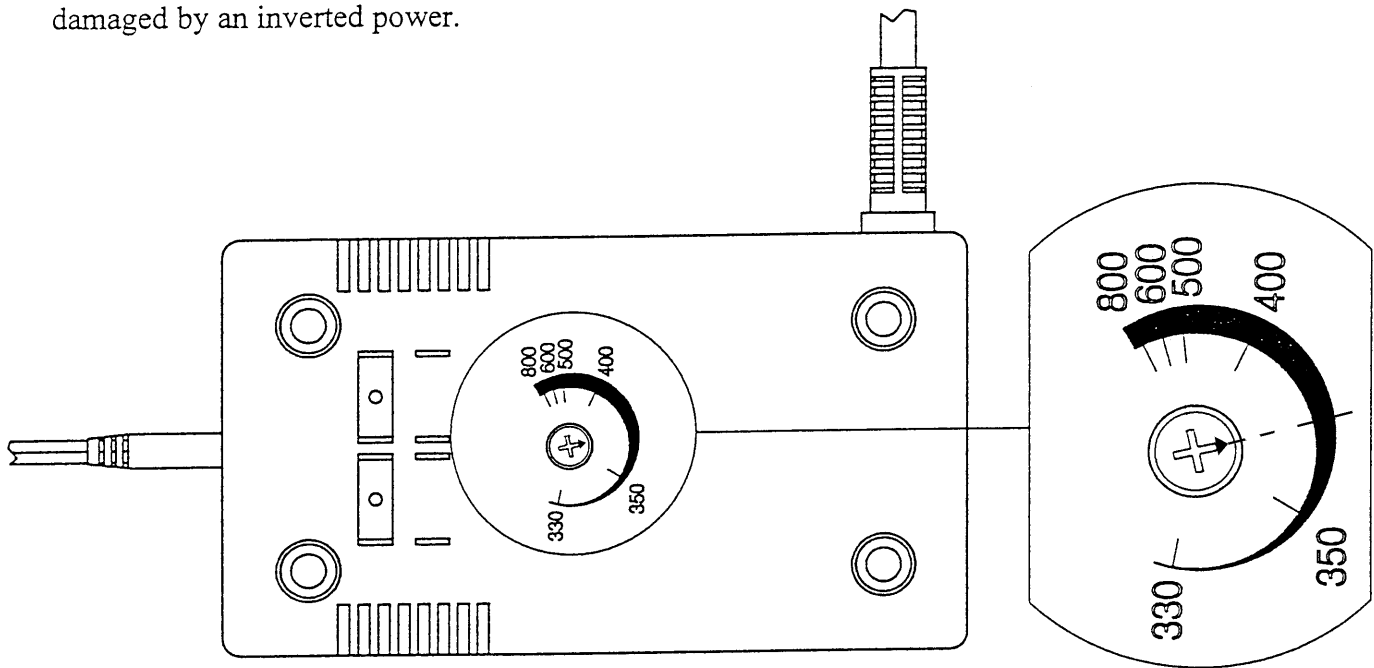

Check that the jumpers on the D08748 board are in HIGH GAIN position.

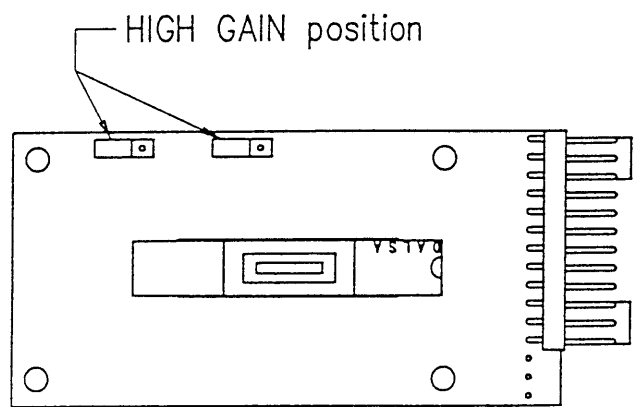
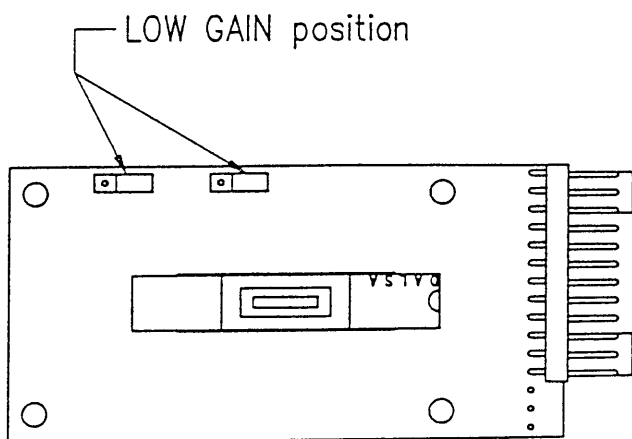

Connect the video cable to the Dolby processor only when it is off.
Thread a digital film on the projector and after having connected an oscilloscope to the processor (DA10, DA20, CP500 or CP650) following Dolby instructions, start the projector.



Now try to find the optical alignment between the LED and the optical lens, acting on the “Q” cam.
The alignment index is the line level on the oscilloscope.
Now you have to find the focus of the digital data acting on the “L” ring after having loosened the
“M” grub screw.

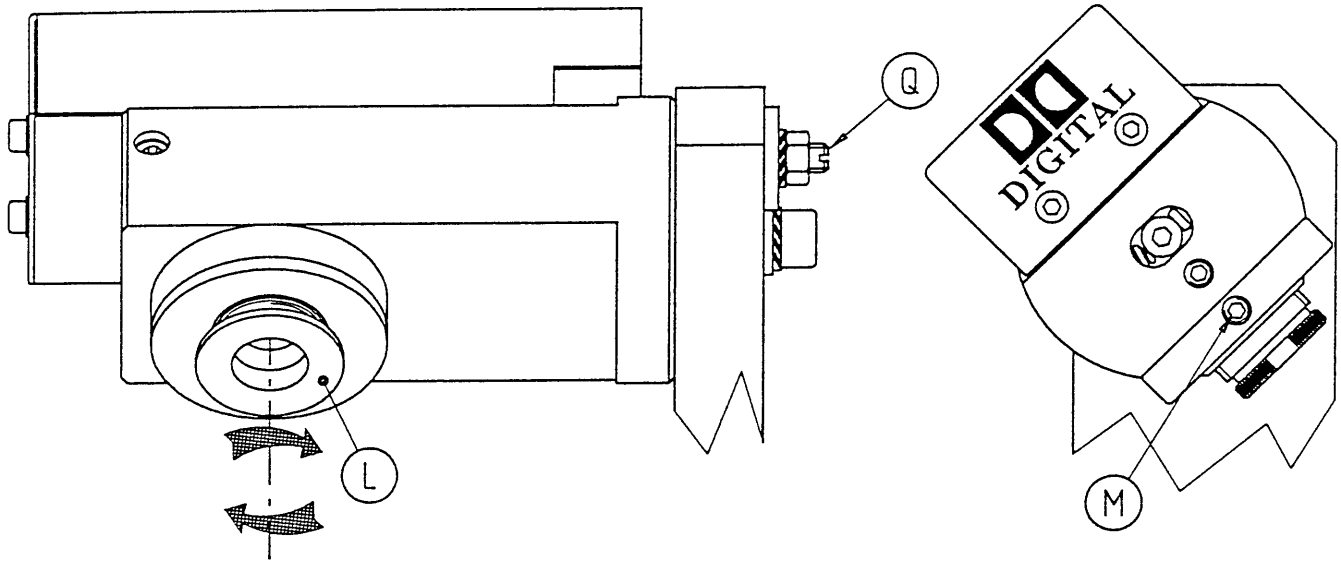

Oscilloscope reading: signal level not set

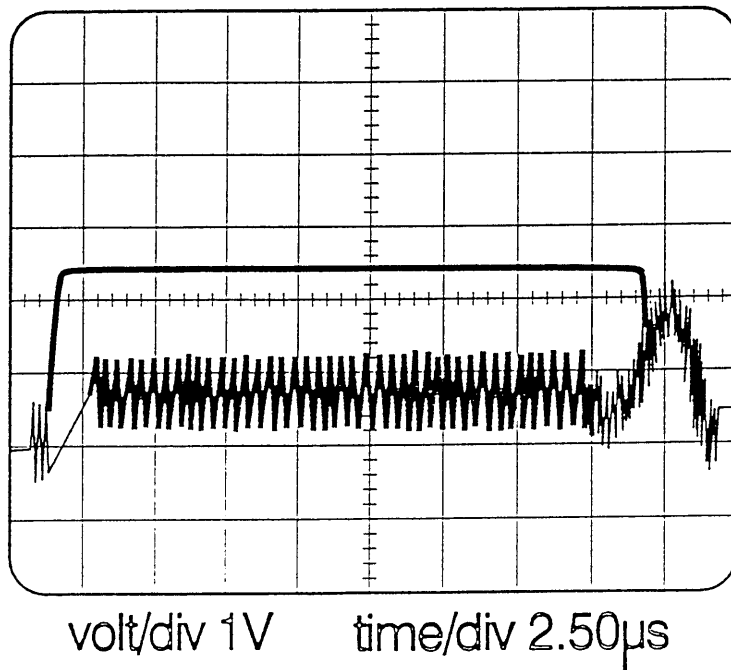



Oscilloscope reading: signal level set

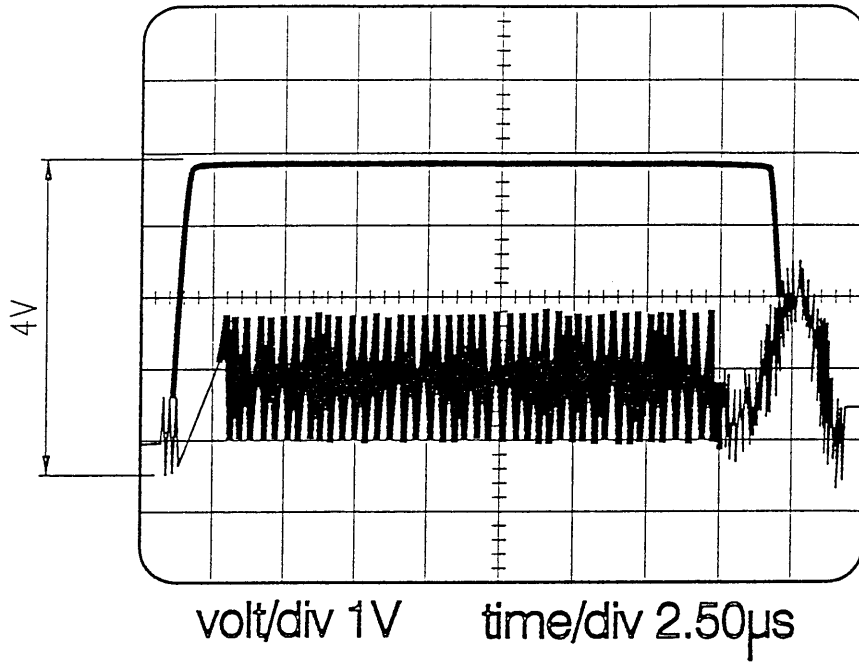

To find the gain of 4V, act on the power supply trimmer as shown on page 4.

Oscilloscope reading: final focusing

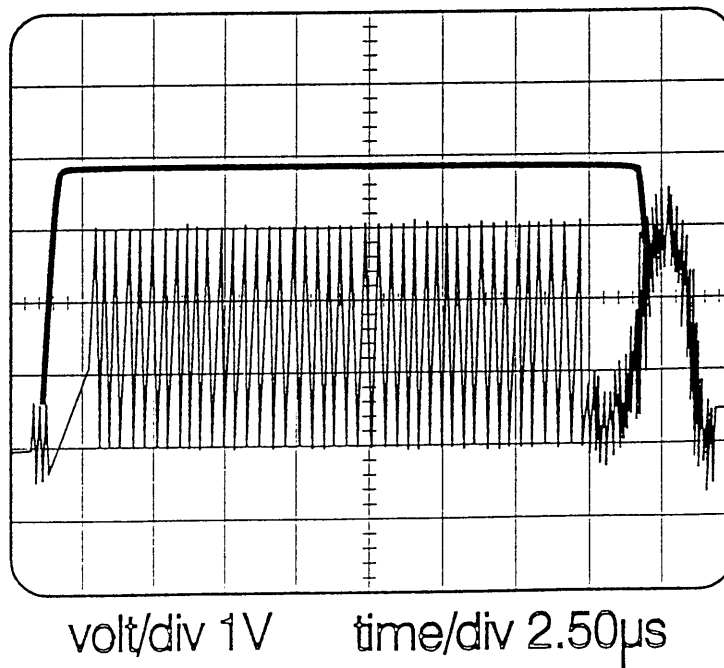



The video signal must be in the upper side as flat as possible with both sides showing vertical slope. On the contrary, please proceed as follows.

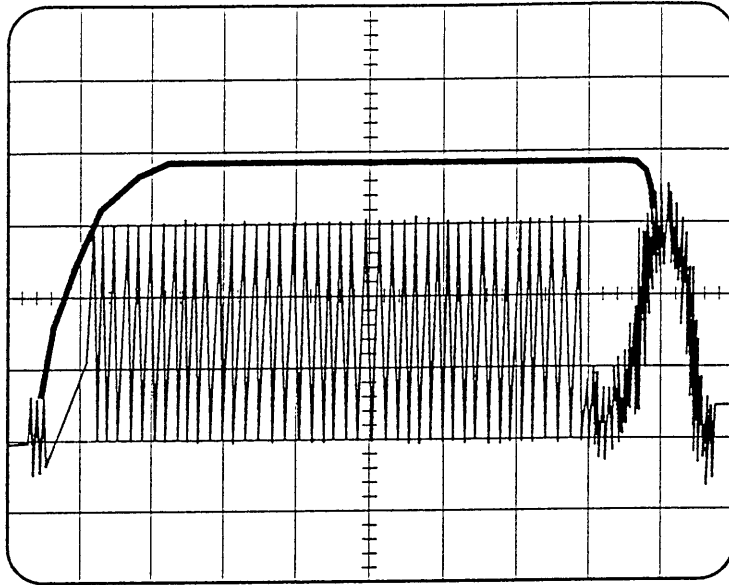

volt/div 1V time/div 2.50 μ s

If the reading on the oscilloscope is similar to the above, you have to loosen the "A" stop screw and move the diode bracket towards the projector casting rotating clockwise the "B" screw.

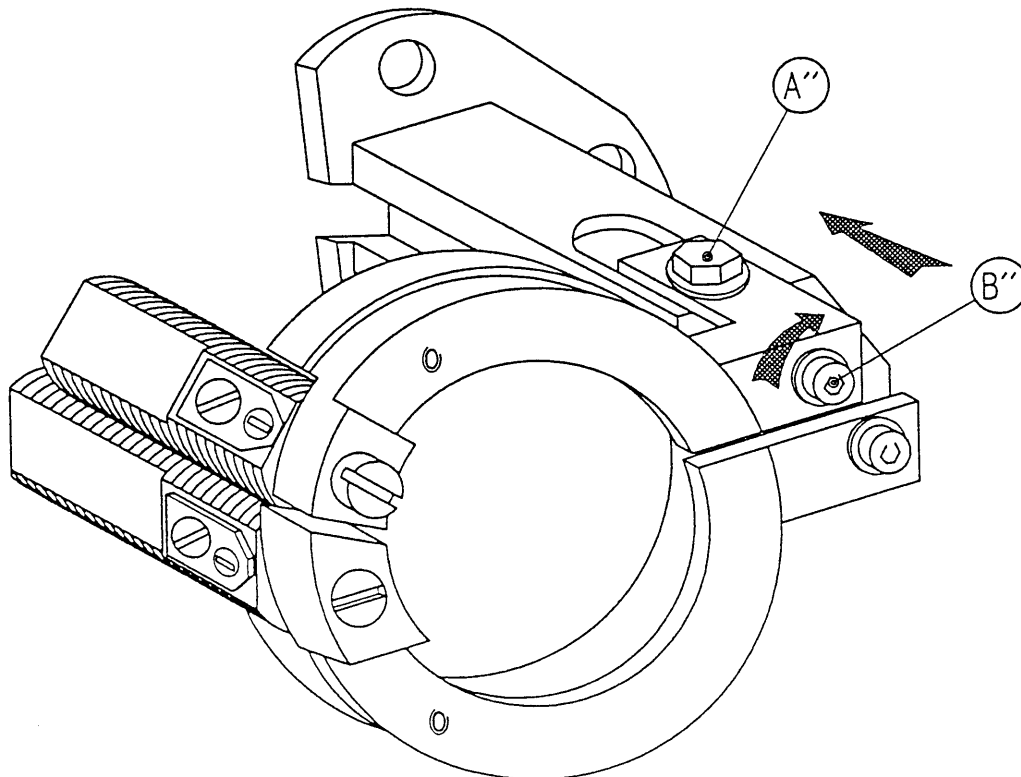

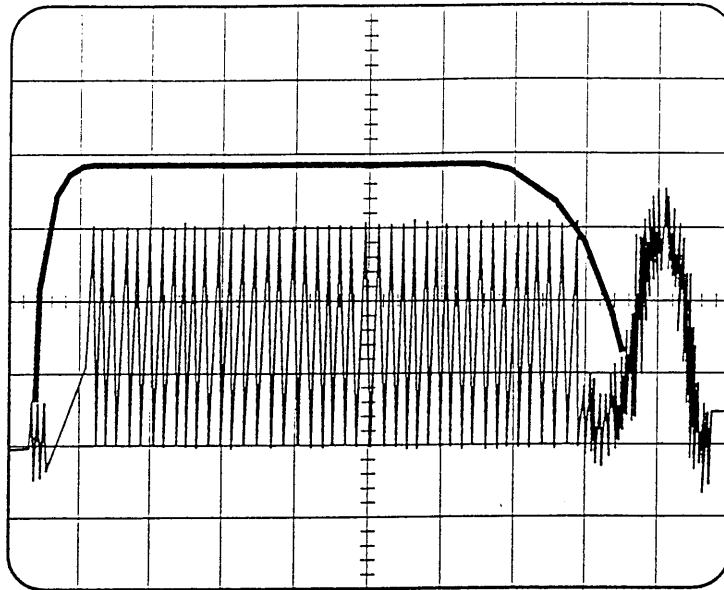

volt/div 1V time/div 2.50 μ s

If the reading on the oscilloscope is similar to the above, you have to loosen the “A” stop screw and move the diode bracket towards the operator rotating counterclockwise the “B” screw.

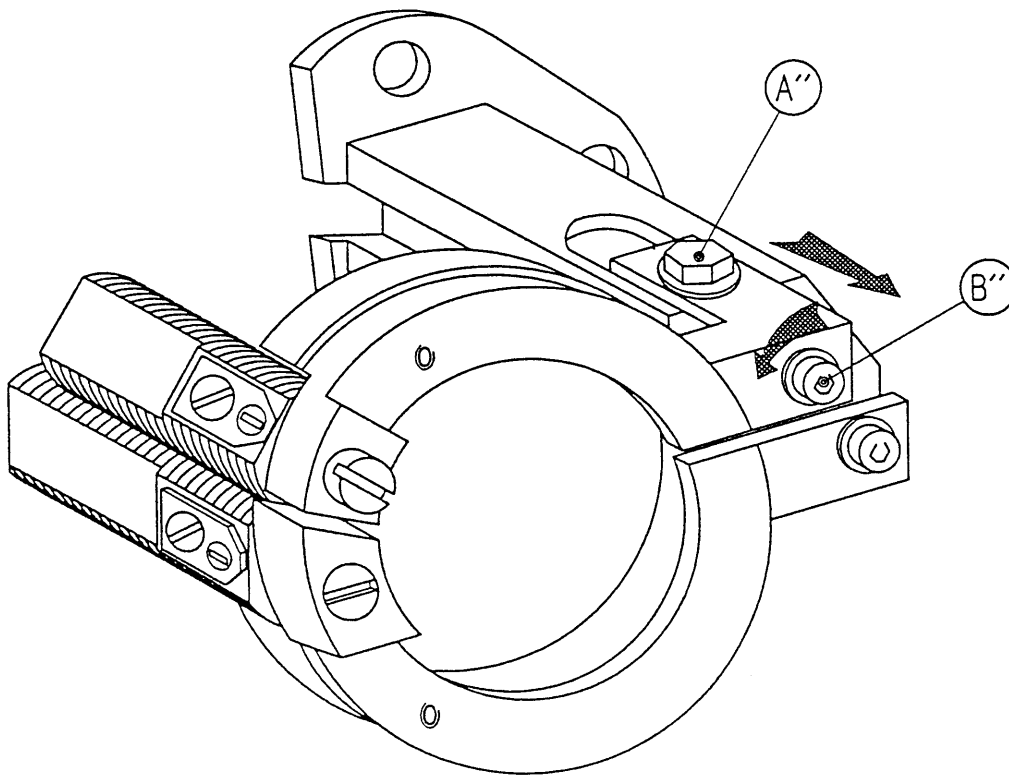

Now tighten the stop “A” screw.



With this operation you perfectly align the diode to the digital data and have a correct light distribution.

The digital data are read on the processor and the green LEDs on the CAT. 671 are on.

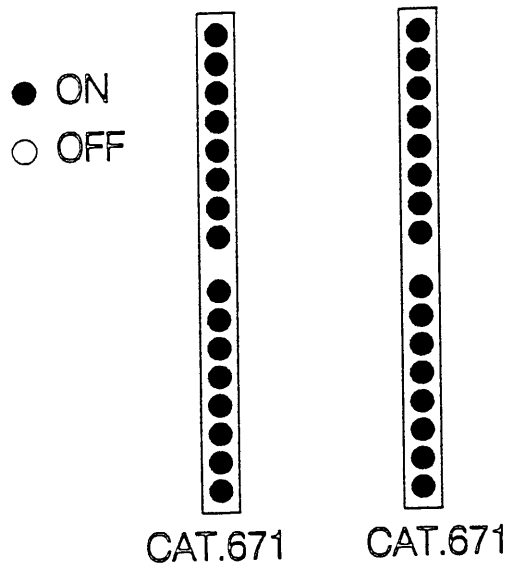

Adjust the focus, rotating the "L" ring and locking it by the "M" grub screw.
Adjust the azimuth, rotating the "O" grub screw and lock by the "N" grub screw.

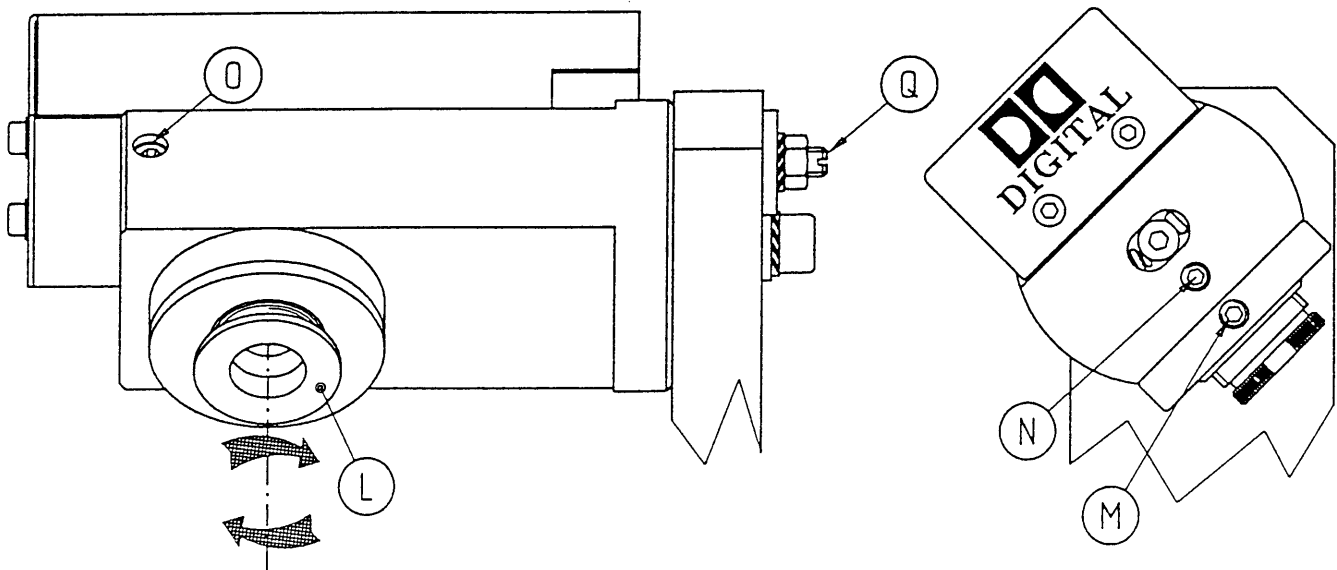



To see if the focusing is correct, please look at the display on the processor. The lower is the number indicated, the better is the focus obtained.

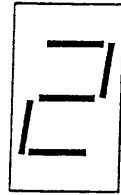

CAT.673

You can check the setting of the azimuth referring to the raising of the digital data shown on the oscilloscope and moving by hand the reading drum; or when the film is running, checking that the first four green LEDs on the CAT. 671 of the processor light up correctly.

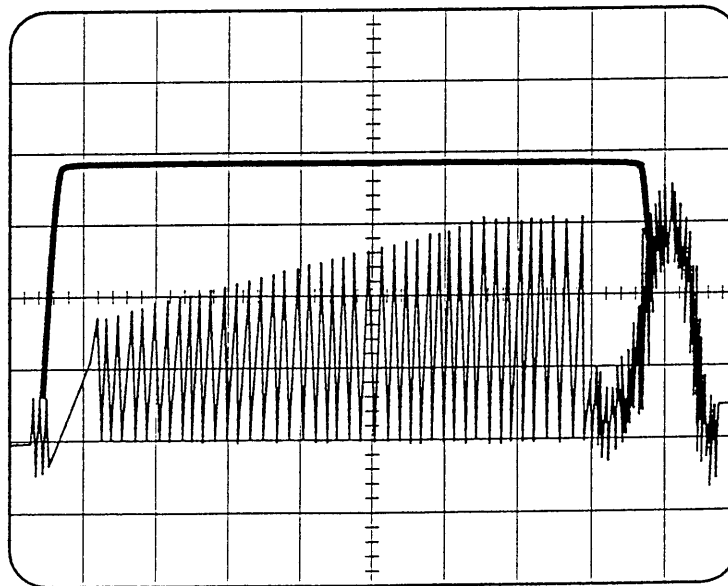

volt/div 1V

time/div 2.50 μ s

Azimuth not correct



Azimuth not correct

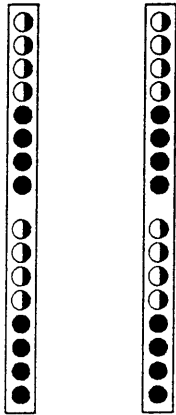

CAT.671 CAT.671

Azimuth not correct

- ON
- OFF
- ◐ FLASH

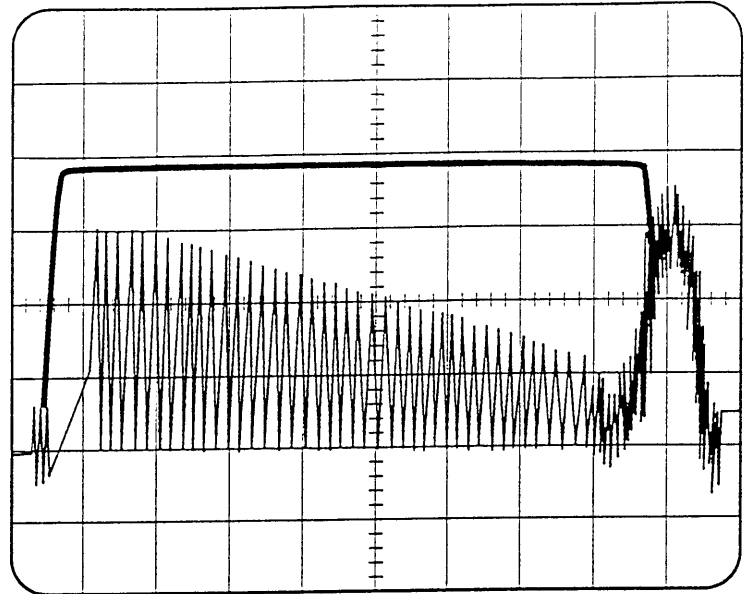

volt/div 1V

time/div 2.50μs

Azimuth Correct

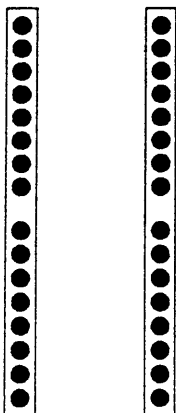

CAT.671 CAT.671

Azimuth correct

- ON
- OFF
- ◐ FLASH

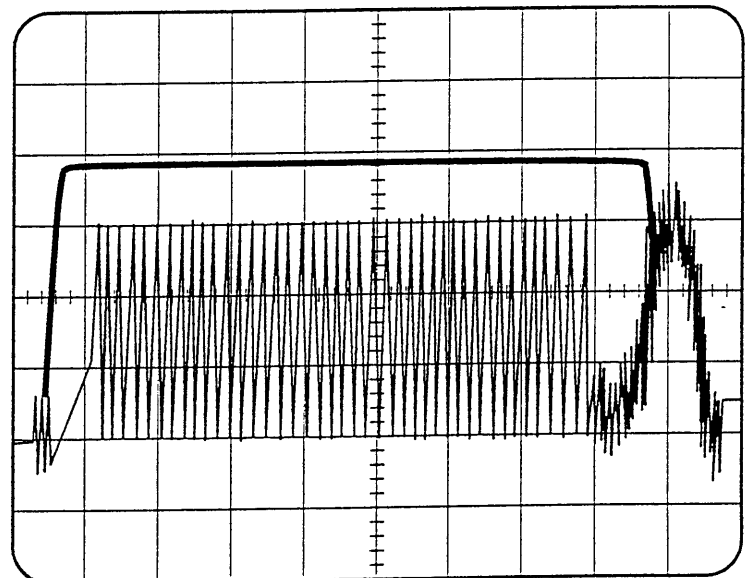

volt/div 1V

time/div 2.50μs



DIGITAL DATA CENTERING

The digital data can be not correctly centered to the CCD on reading board.
You can easily see when the alignment is not correct, looking at the lighting up of the first four green LEDs on the CAT. 671 and looking at the oscilloscope showing a not centered reading of the video signal.

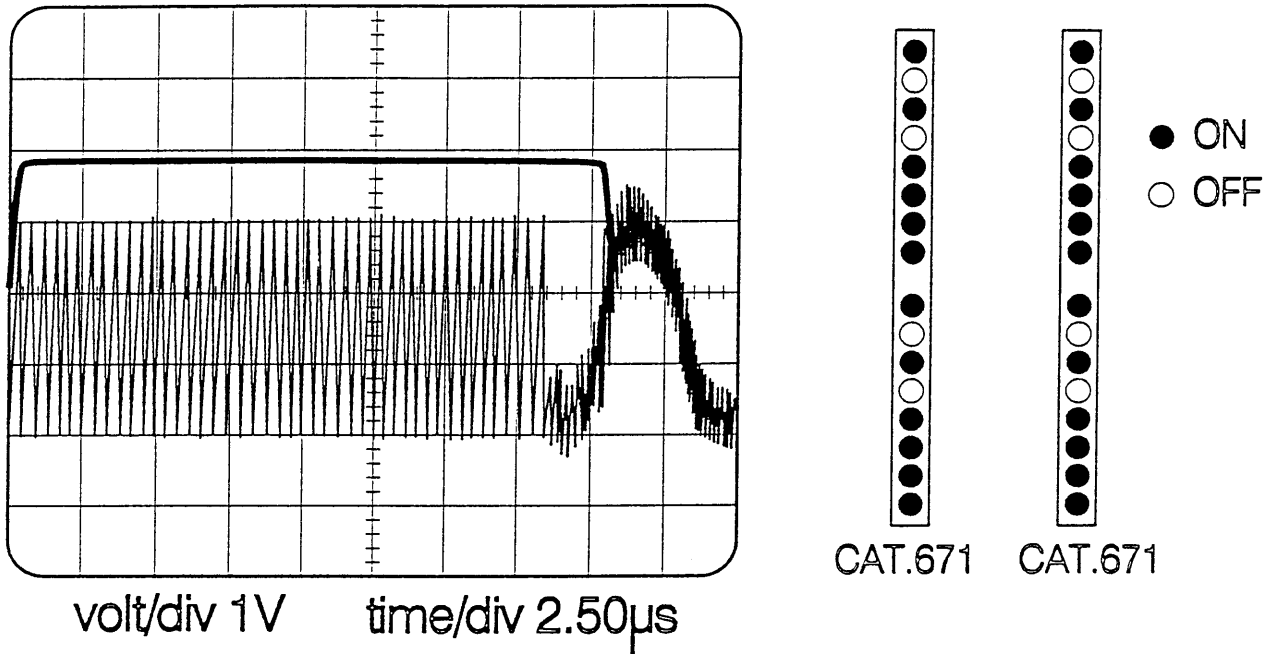

If the reading on the oscilloscope is similar to the above one, with a not correct reading of the data on the CAT. 671, you have to move the CCD board towards the operator after having loosened the "K" screws.

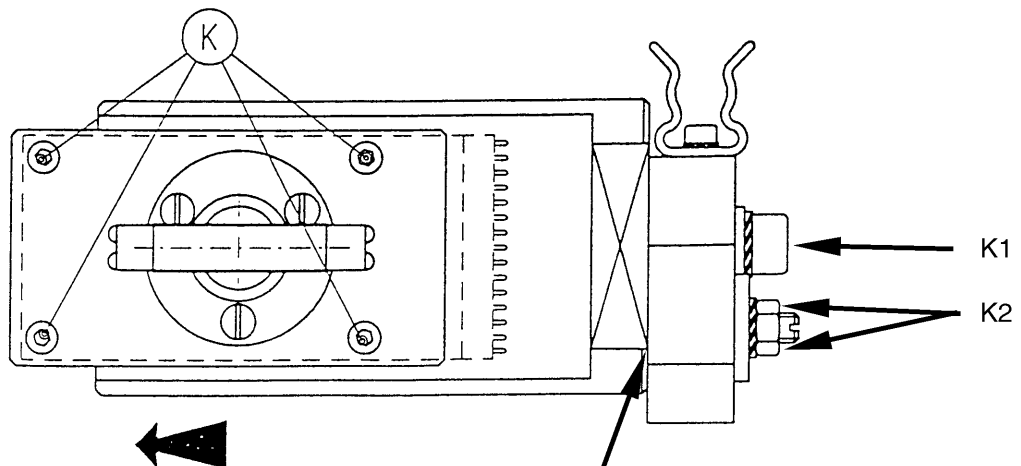

If this adjustment is not enough, shim #D10744 needs to be placed between the vertical bar #D06659 and the CCD holder #D08746.

Remove bolt 'K1', but DO NOT loosen nut 'K2'. Place shim on D08746, with notches on shim and holder matching. Re-attach holder to vertical bar and tighten 'K1'.



If this operation is not sufficient to have a correct alignment, you will have to fit a spacer D07211 between the main casting and the 8V794 bracket.

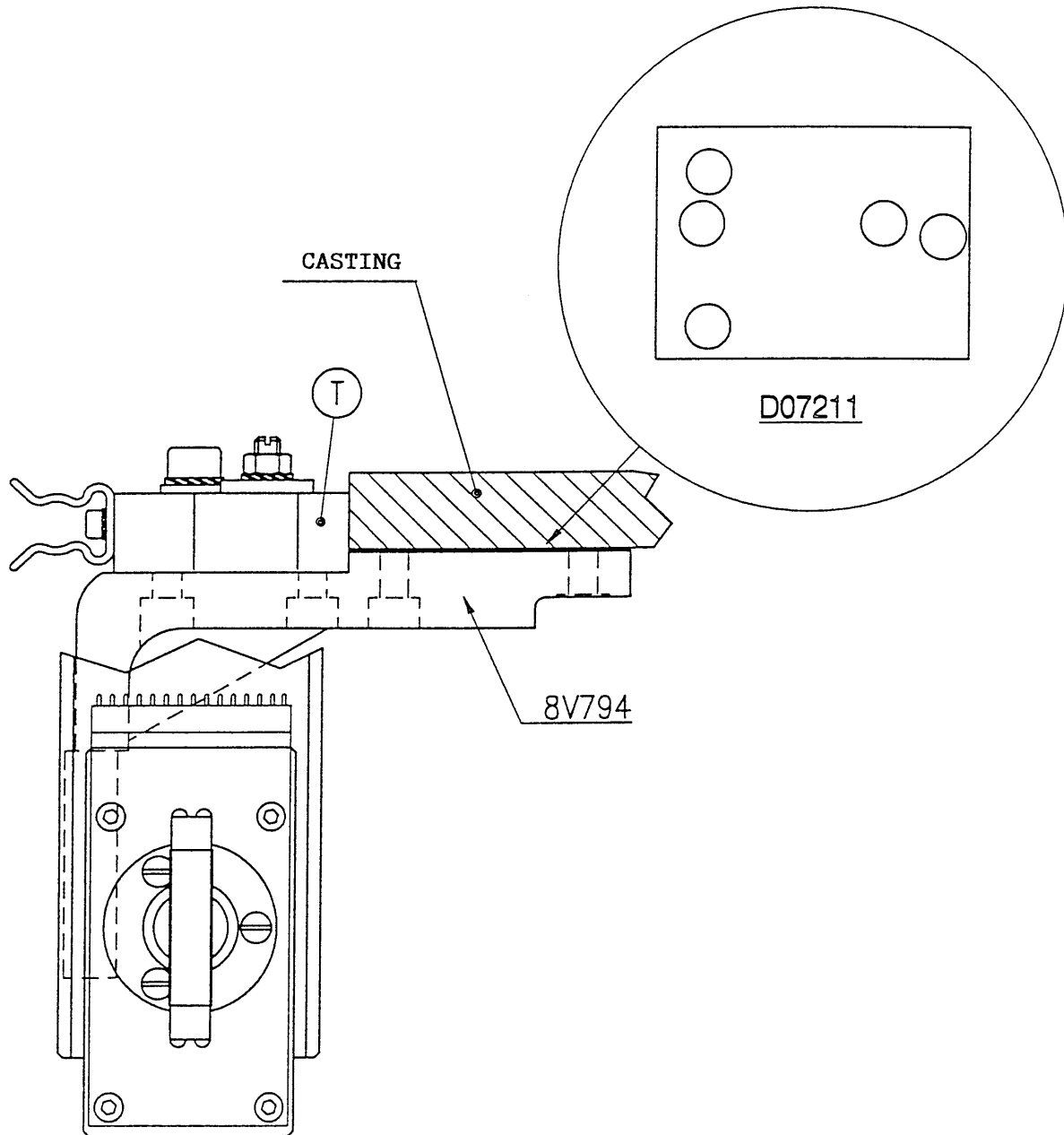

Then please check again the previous settings as focus, azimuth and so on.



On the contrary if we have a situation like the one hereunder, that is the signal is shifted on the right side of the oscilloscope screen, please proceed as follows:

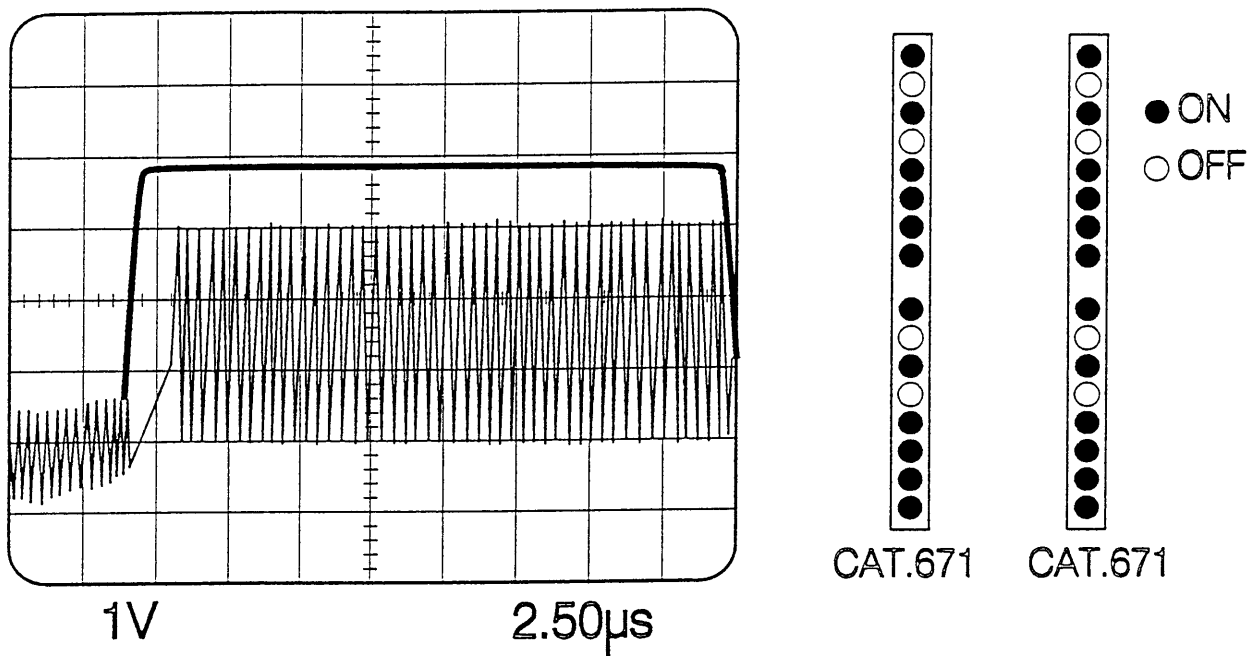

Loosen the “K” screws and move the CCD board towards the projector until the Dolby processor can read correctly the data.

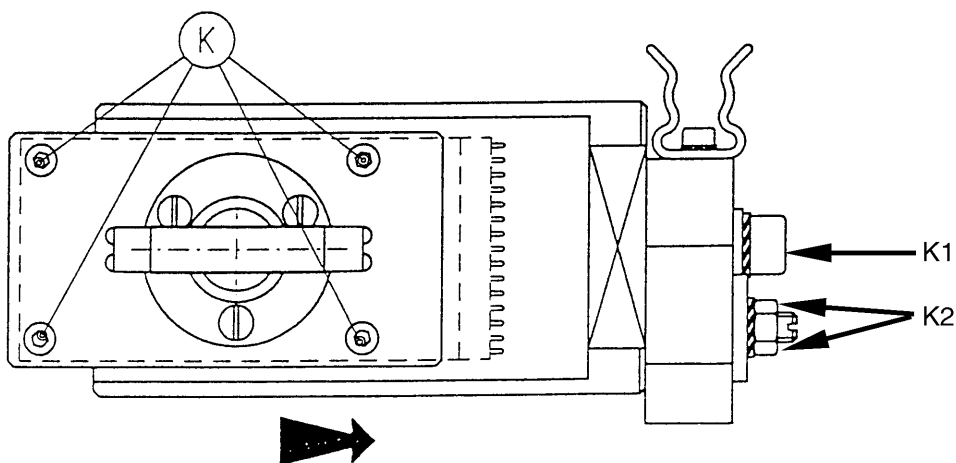

If this adjustment is not enough, shim #D10744 (if in place) needs to be removed.
If two or more shims are in place remove one at a time.

Remove bolt 'K1', but DO NOT loosen nut 'K2'. Remove ONE shim.
Re-attach holder to vertical bar and tighten 'K1'.



Then if the reading on the oscilloscope is the one shown hereunder, the data are centered and you have to tighten the "K" screws.

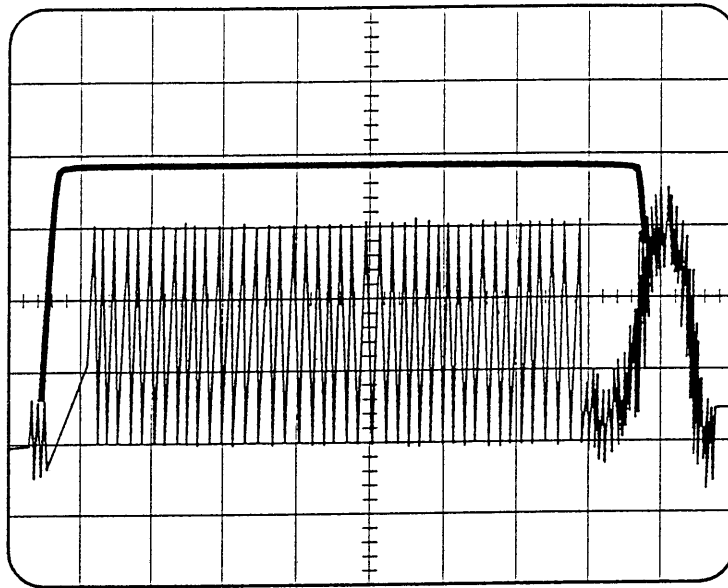

volt/div 1V time/div 2.50 μ s

If this is not sufficient to have again a correct alignment, you have to place a spacer D07211 between the "T" plate and the 8V794 bracket.

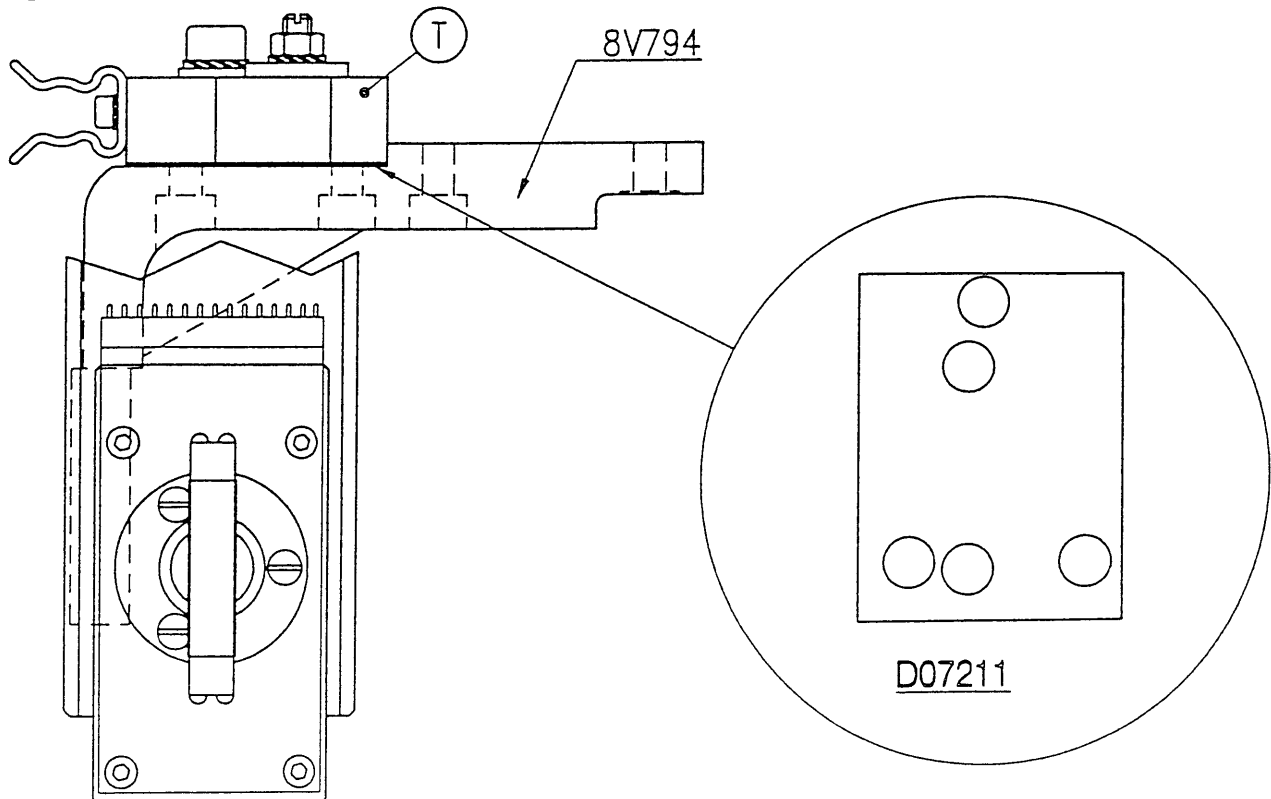

After this, please check again the previous settings as focus, azimuth and so on.



By the film test CAT. 530 or a film from it made it is possible, connecting a PC to the serial port of the processor and by the Dolby DRAS10 program, to check the setting and/or make the necessary corrections.

The PC screen shows coloured fields in which some numerical indexes allow to check the alignment. The field colours are red, yellow or green in case the alignment is not correct, doubtful or correct. The numerical value indicates if the adjustment is correct.

You can find the fields regarding the FOCUS, AZIMUTH, MAGNIFICATION and ERROR RATE. Acting mechanically for each function as previously described, it is possible to align or improve the alignment already made.

The field MAGNIFICATION must show a value between 97% and 103%.

If the value is lower than 100% the CCD board must be moved away from the sound lens. To do so, you can use max. 0.2mm washers as spacers to be placed under the studs of the CCD board.

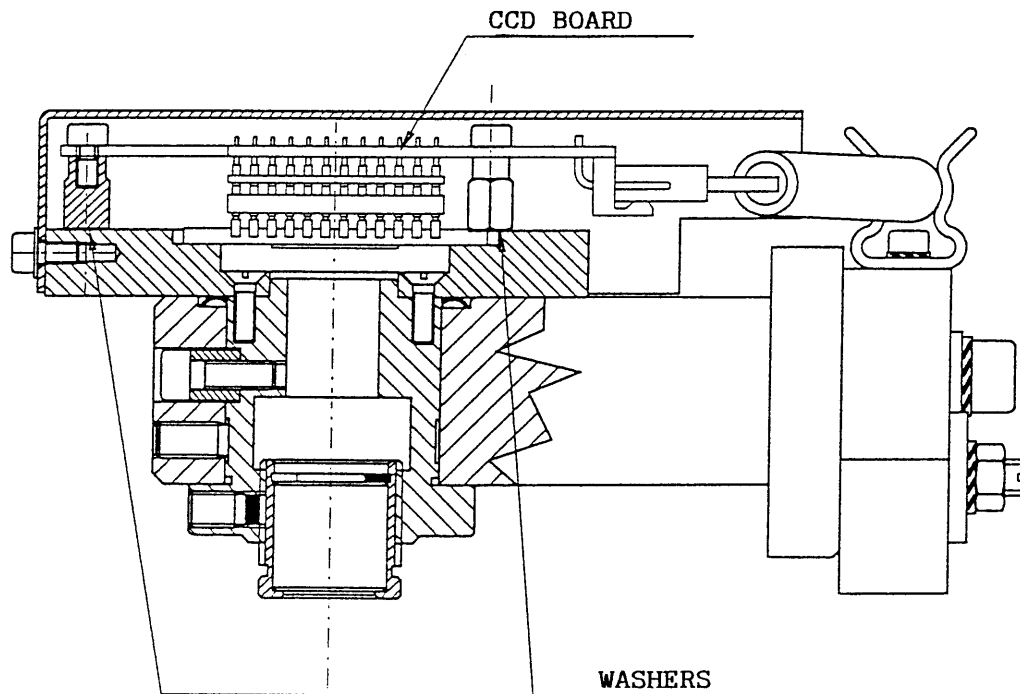



If the value is higher than 100% move the “T” bracket in the arrow direction after having loosened the “U” screws.
If this is not sufficient, loosen the “V” screws and move all the assembly using the play between holes and screws.

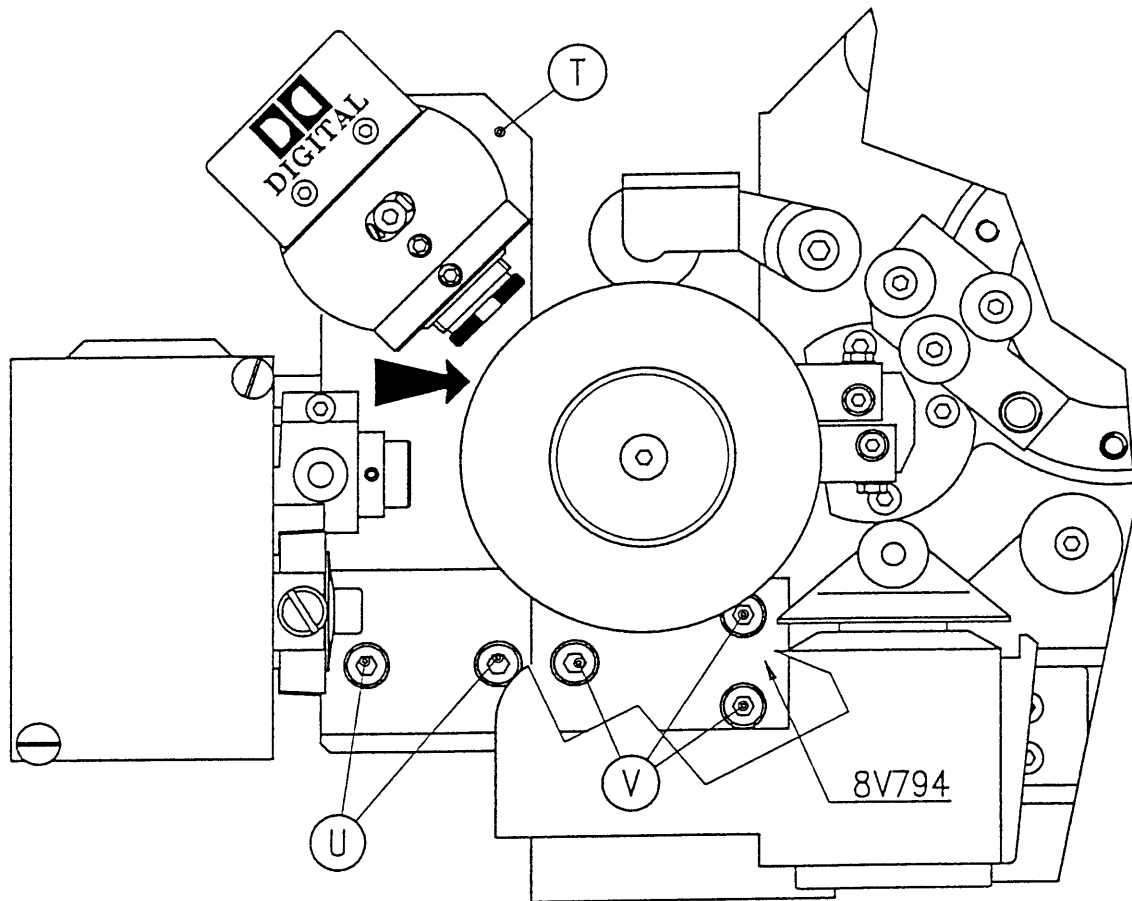

After this operation proceed again with the alignment of the light and with the data focusing.



DOLBY CELL POSITIONING
TEMPLATE

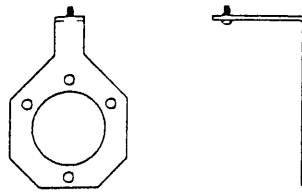

D07097

HOOK WRENCH FOR
INTERNAL RING

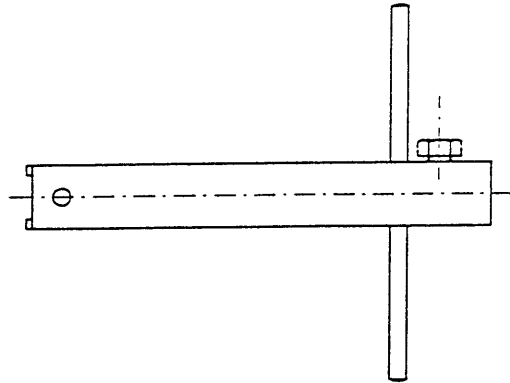

5551-19

HOOK WRENCH FOR
EXTERNAL RING

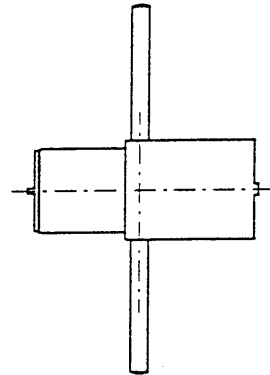

5551-18

SOUND DRUM
ALIGNMENT KIT

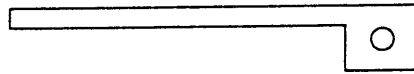

A833

RED LED ALIGNMENT TOOL

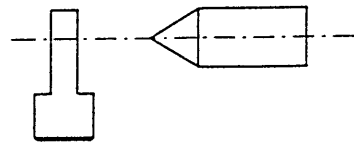

A875

DIGITAL READER BRACKET SPACER
&
EXCITER LAMP HOUSE BRACKET SPACER

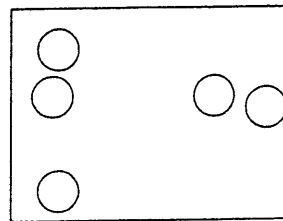

D07211

DIGITAL READER HOLDER SPACER

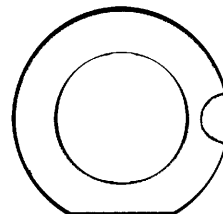

D10744