

# Film-Tech

The information contained in this Adobe Acrobat pdf file is provided at your own risk and good judgment.

These manuals are designed to facilitate the exchange of information related to cinema projection and film handling, with no warranties nor obligations from the authors, for qualified field service engineers.

If you are not a qualified technician, please make no adjustments to anything you may read about in these Adobe manual downloads

[www.film-tech.com](http://www.film-tech.com)

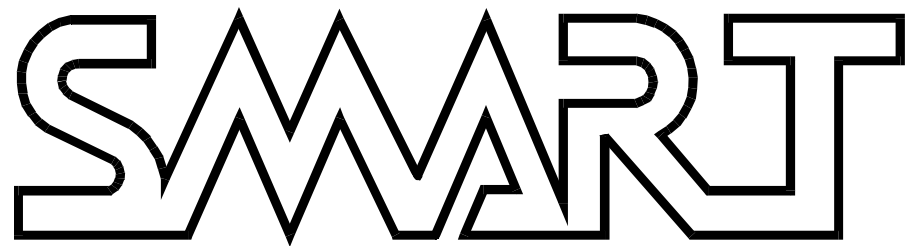

**MT4-16 MovieTimeS™  
Digital Phone Announcer**

**Installation and Operation Manual**

5-1-00



### Glossary of terms used in this manual.

- TELCO** Telephone company line that comes to your building.
- KSU/PBX** Key Service Unit. A telephone system that has multiple lines. May be mechanical buttons or electronic. PBX means Private Branch Exchange.
- 117 VAC** 117 volts AC current. The wall power pack furnished in North America is a 12 VDC 500 mA supply. If this product is used in countries that have an AC line voltage of 220-240 volts AC then a suitable power pack must be furnished by the customer.
- Modular cable** Standard connection to telephone wall sockets and phones. Known as RJ-11 plugs.
- Central Office** Origination of telephone service at the phone company.
- LED** Light Emitting Diodes. Solid state lamps.
- REN** Ringer Equivalency Number. This number represents the load on the phone line. Telephone instruments and accessory products have this number on the product.
- HOOK FLASH** If you have CALL WAITING or other features supplied by the phone company as part of your service, pushing the button on the cradle of the phone may cause a problem with the MovieTimes. We recommend you suspend these services by calling the phone company and having the additional services removed.

# The "pound" button on the touch-tone phone allows you to enter the programming portion of the program.

\* The "asterisk" button on the phone is also part of the programming sequence when receiving, deleting, or recording new messages.

# Table of Contents

<b>Introduction</b>	
System Description	4
Sample Application	5
<b>Installation</b>	
General Information	6
Standard Installation	6
KSU / PBX Installation	7
Installation Notes	8
<b>Lights &amp; Indicators</b>	
Mode Light	9
Line Lights	9
<b>Set up / Operation</b>	
Factory Reset	10
Seizing Control	10
Record	10
Review	11
Delete	11
Set Rings	11
Set Repeats	12
Set Master Password	12
Memory Request	12
Memory Test	13
Restore Defaults	13
<b>APPENDIX A - Message Configuration Table</b>	13
<b>APPENDIX B - Command Summary</b>	13
<b>APPENDIX C - Default Settings</b>	14
<b>SUGGESTIONS FOR RECORDING MESSAGES</b>	14
<b>APPENDIX D - Specification</b>	15
<b>APPENDIX E - Contacting SMART Customer Support</b>	16
<b>APPENDIX F - Notices &amp; Warranty</b>	16

# INTRODUCTION

## SYSTEM DESCRIPTION

The MovieTimeS is an advanced digital call screening and messaging system designed to answer calls with an informative greeting, then let the callers select any number of the additional pre-recorded messages.

The MovieTimeS is a four-line unit capable of handling four calls simultaneously.

Message recording and system programming functions are accessed locally or remotely by a standard touchtone telephone.

Additional standard system features include:

- Simple to use programming interface through touch tone phones

- 4 Easy access messages from the main menu

- Up to 24 additional messages from a *movie selection* menu

- Each caller hears an independent message while sharing digital memory with others.

- Flash Memory will not be erased by power failures or unplugging the product.

- Message times in each box are variable. A short message will terminate at the end of the message and will not use the entire time-space that may be available. This avoids long periods of silence.

## MovieTimeS Messaging Flow

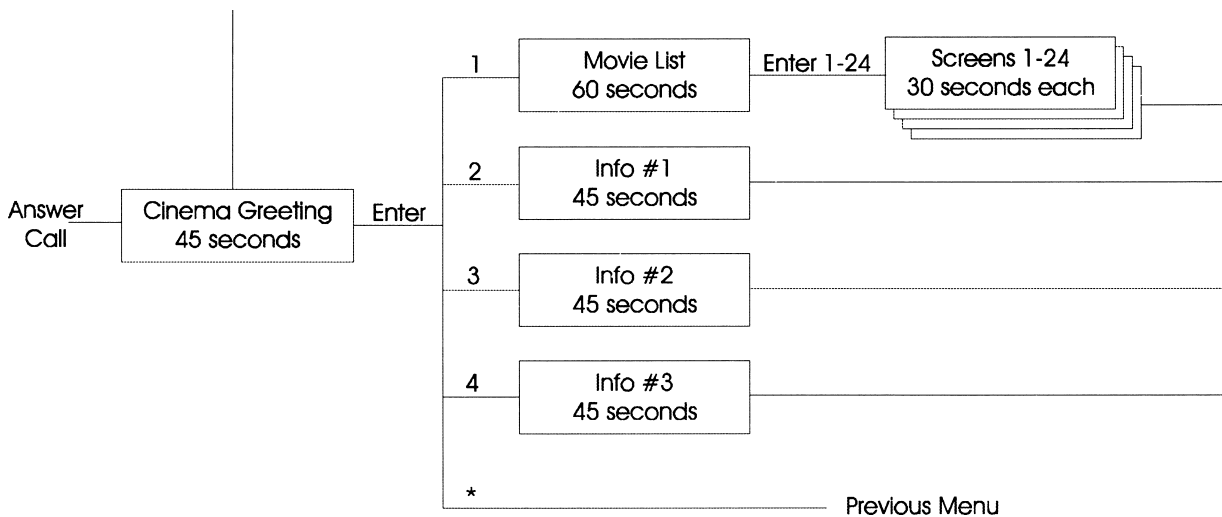

## SAMPLE APPLICATION

The MovieTimeS was designed for use in movie theaters to announce up to 24 movies and the show times for each picture. Other information may be selected about your theatre and programs.

### The typical Movie Theater application

Greeting Message	Thank you for calling Megaplex Theater. If you are calling for show times please press 1. If you need information on ticket pricing, please press 2. Directions to our theatre are available by pressing 3. A list of exciting new upcoming features may be heard by pressing 4.
Movie List Message #1	To hear the show times for Titanic, press 1. Blast from the Past, press 2. The 60 year anniversary re-release of "Wizard of Oz" press 3, (continue for all screens).
Information Message # 2	Our standard ticket prices for Adults are \$6.50, Children \$4.50 and Seniors \$2.50 for all shows except the Sunday matinee before 5 P.M. when all tickets are half price. Be sure to ask about our group and movie club pricing.
Information Message #3	The Megaplex Theatre is in the new Northside Shopping Mall at the corner of Northside Drive and Montford Drive. We are right across from the Macy's Department Store.
Selection Message #4	Star Wars is coming to the Megaplex theatre on May 21. This highly anticipated blockbuster will be played on the new SMART Center Surround 3X digital surround system. Other exciting new releases we have booked are .... etc.

## INFORMATION SEQUENCE:

Callers will receive the Greeting Message. They may choose from four information boxes. One box lists the current movies and a number to select. After each message the caller is returned to the Greeting Message. Hanging up completes the call.

Please see our suggestions for recording messages on Page 14.

**You must know the secret password in order to enter the recording, delete, and review modes. We suggest you give this password only to the staff members that use this machine. Since the MovieTimeS can be programmed remotely, we suggest you change the password when a person leaves your staff.**

*The MovieTimeS answering system works only with a touch tone phone. You may wish to tell callers on the opening greeting message to call another number if they have a rotary (pulse) type phone. This special line can use our MovieTimeS DASA300 digital announcer on the phone line. Please call your dealer or the factory for details.*

# INSTALLATION

## GENERAL INFORMATION

Install the MovieTimeS in close proximity to the telephone line which the unit is to answer and within 6' of a 117VAC wall outlet. The MovieTimeS is designed to mount on a wall, shelf or other flat surface. When mounting the unit, be sure to leave clearance at the rear of the unit for connection accessibility.

## STANDARD INSTALLATION

Install the MovieTimeS directly on the incoming telephone lines. Each line must be a dedicated TELCO line.

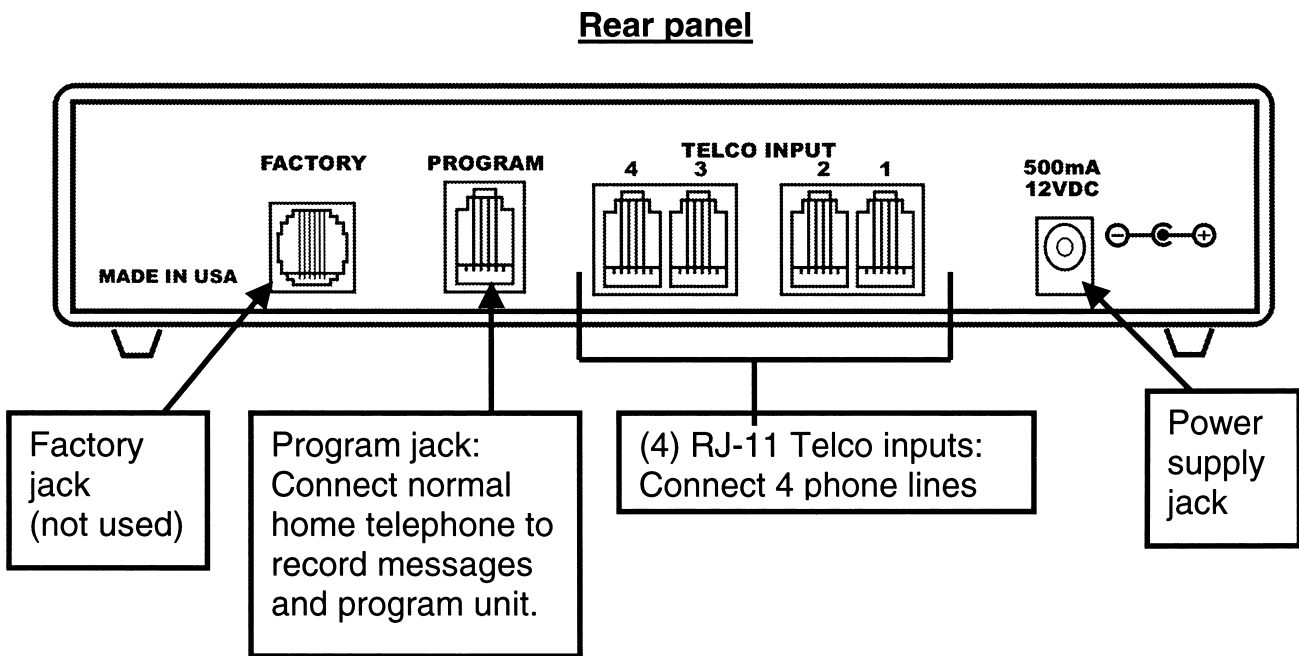

Follow steps 1-6 for standard installation:

1. Attach one end of the modular telephone cable (included) to the TELCO jack of the MovieTimeS.
2. Attach the other end of the modular telephone cable to the wall jack of the line intended for use.

**NOTE: Repeat steps 1- 4 for the second, third and fourth lines**

5. Attach the included power supply to the 12VDC jack of the MovieTimeS.
6. Plug the other end of the power supply into the 117VAC wall outlet.

The MovieTimeS must be installed on the phone company side of your phone system. If installed directly to an unsuitable extension line the phone system or the MovieTimeS may be damaged. If you are not familiar with how your phone system is installed, or do not know which lines go directly to your phone company please find a qualified person to perform the installation.

## INSTALLATION NOTES

### Required Lines

The MovieTimeS does not require phones to be attached to the PHONE connectors for operation. The MovieTimeS does require a working phone line to be attached to the TELCO connector in order to seize control from the associated PHONE connector.

### Line(s) to be Answered

The MovieTimeS can handle four telephone lines. The MovieTimeS can only answer the line (or lines) that it is attached to, additional phone lines must bypass the MovieTimeS and ring straight through to other instruments.

### Hunt Groups

Hunt groups are a set of lines that all answer to the same number. If the first number in the group is busy the next call rings in on the next line in the group. This service is arranged through the phone company. If installing the MovieTimeS on lines arranged in a hunt group, be sure to place the unit on the first four incoming lines. Be aware that the MovieTimeS can only handle four calls simultaneously. If placed in a hunt group with more lines than the four lines the MovieTimeS can handle, the additional calls bypass the MovieTimeS and ring straight through to other telephones. You may install additional MovieTimeS machines for each four lines in the hunt group.

### Hook Flash Transfers

Some installations may use services such as CENTREX or CALL WAITING that rely on a Hook Flash signal being sent to the Central Office. The MovieTimeS is not compatible with these services and will interfere with the Hook Flash signal.

### CPC

The MovieTimeS is designed to use the Calling Party Control signal sent from the Central Office to sense when the caller has hung up the phone. Not all Central Offices support CPC signaling. If the MovieTimeS does not receive the CPC signal it may take as long as 90 seconds after message play is complete to return to normal operation and calls also ring through even if the calling party has hung up during the message or transfer.



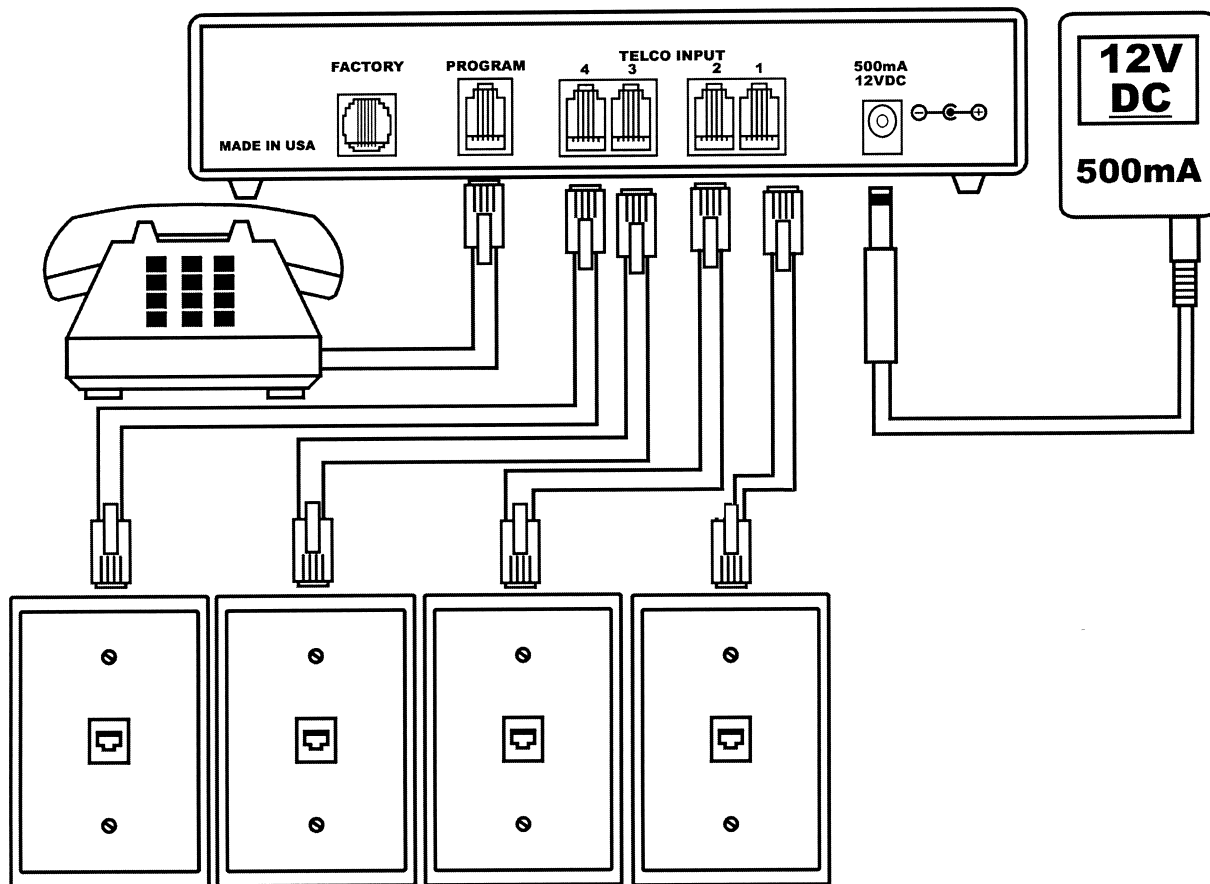

## LIGHTS & INDICATORS

The MovieTimeS front panel has a multi colored Mode LED and a green Line LED for each available line.

### MODE LED

The Mode LED normally flashes green to indicate normal operation. The Mode LED also flashes amber as the MovieTimeS processes commands.

In the event of a system failure, the mode LED flashes red.

### LINE LEDs

The Line LEDs will show green whenever the MovieTimeS is in control of the line.

The FACTORY jack on the back of the MovieTimeS must not be used by customer. This jack is used by the factory to load instructions to the internal computer. If program upgrades are available in the future, your machine may be upgraded to the new software by returning it to the factory to load the new operating program.

*Note: You must delete a message before recording a new message. This is necessary because your new message may be shorter than the old one and the last part of the old message will remain. Deleting the message restores a blank memory box, ready for the new message.*

## Maximizing the capability of the MovieTimeS.

This digital answering device has 24 message boxes for show times on 24 screens. If you have a 30 screen complex, often a movie is played in interlock on multiple screens. We suggest you mention the movie once and use a show times box to give the show times for all showings.

If you have more than 24 movies you may use one show times box for two different movies if they run the at same times.

If you have a 10-plex, you will have 14 unused show times boxes. You may elect to use these empty boxes for movie reviews of the current movies. For example: In the Movie List box say "For Titanic press 2, for a review of this movie by the leading film critics, press 23." Then record a review in box 23.

## SET UP / OPERATION

### FACTORY RESET

The MovieTimeS can be reset to the factory default settings by holding the mode button down while power is applied. This erases all messages and brings the system to a fresh state which provides a good starting point for system configuration. See appendix C for a full listing of the default values.

### SEIZING CONTROL

The MovieTimeS is setup by seizing control of the unit to enter Command Mode and then entering a series of two digit command codes to manipulate settings and record messages. Seizing control of a unit can be done by one of two ways:

- **Local** - Through the use of a phone that is installed in the PGM jack of the MovieTimeS. Control is seized by picking up the handset of the local phone, listening for a Beep tone and then entering # \* \* followed by the Master Password (factory default = 1 2 3 4"). After entering # \* \* followed by the Master Password, the dial tone may change to a busy tone or start ringing, ignore it. Within 5 seconds of entering the Master Password the MovieTimeS seizes the line and plays a triple beep indicating it has been placed in Command Mode.
- **Remote** -The unit answers and plays the Greeting message after a predetermined number of rings (factory default = 1). If the message is not present, the unit answers and plays a single beep. After the unit answers you may proceed by entering # \* \* followed by the Master Password (factory default = "11 2 3 4"). Within 5 seconds of entering the Master Password the MovieTimeS seizes the line and plays a triple beep indicating it has been placed in Command Mode. Failure to enter a password in 20 seconds, or after the end of the message results in a disconnection.

**NOTE: When control has been seized from the Remote, a busy signal is heard on the Local telephone you are using.**

Once the unit is in Command Mode the user may start entering commands. All commands start by entering "\*" and end by entering a "#". After each valid command, a single success beep sounds. Invalid entries are indicated by a double beep error tone.

**NOTE: Seizing control causes any calls in progress on the other line to be disconnected.**

## MESSAGE RECORD

The Message Record commands allow the user to record one of the available messages. The available messages and message lengths vary with the Message Table and installed memory, see the Message Table command for more information. After the command is entered, the MovieTimeS plays a steady series of short beeps (ready tones) At any point after the ready tones begin, the user may enter " \* " to start the recording. Recording continues until the user enters " # " or the maximum record time for the message is reached. At this point, the MovieTimeS plays a success beep and is ready to receive the next command . The error tone sounds if the user attempts to record a message that is not available in the current Message Table or if the selected message has previously been recorded and not erased.

*Note: You must delete a message before recording a new message. This is necessary because your new message may be shorter than the old one and the last part of the old message will remain. Deleting the message restores a blank memory box, ready for the new message.*

Syntax:

\*5 0 0 1# through \*5024#  
| Record Screen Message #1 - #24  
\*50 24#  
\* 5 0 3 1 # Record Greeting Message  
\* 5 0 3 2 # Record Movie List Message  
\* 5 0 3 3 # Record Info. Message #1  
\* 5 0 3 4 # Record Inf o. Message #2  
\* 5 0 3 5 # Record Inf o. Message #3

## MESSAGE REVIEW

The Message Review commands allow the user to review each of the messages. After the command is entered the requested message plays. After message play completes the user hears the success beep and returns to command mode ready to enter the next command. The user may enter " # " at any point during message review to abort the play back, at which point the user hears the success beep and returns to command mode ready to enter the next command. If the selected message has not been recorded the user hears the error tone and returns to command mode ready to enter the next command.

Syntax:

\*6 0 0 1# through \*6024#  
| Review Screen Messages #1 - #24  
\*6 0 2 4 #  
\*6 0 3 1 # Review Greeting Message

- \*6 0 3 2 # Review Movie List Message
- \*6 0 3 3 # Review Info. Message #1
- \*6 0 3 4 # Review Info. Message #2
- \*6 0 3 5 # Review Info. Message #3

## MESSAGE DELETE

***A current message must be deleted before recording a new message. This will remove any remnants of the old message, if the new one is shorter.***

Each Message Delete command allows the user to delete any one of the messages. While the message is being deleted the user will hear the system busy signal for a period of time followed by the success beep, returning to command mode ready to enter the next command.

Syntax:

- \*7 0 0 1# through \*7024#  
     I           Delete Screen Messages #1 - #24
- \*7 02 4#
- \*7 03 1# Delete Greeting Message
- \*7 03 2# Delete Movie List Message
- \*7 03 3# Delete Info. Message #1
- \*7 03 4# Delete Info. Message #2
- \*7 03 5 # Delete Info. Message #3

## SET RING

Set Rings command sets the number of rings that the unit answers on. Valid numbers of rings range from 01 to 15. If a valid number of rings is entered the user hears the success beep and returns to command mode ready to enter the next command. If the entered number of rings is not valid the user hears the error tone and returns to command mode ready to enter the next command.

Syntax... ( X =any value 01 - 15)

- \* 1 1 # X X # Set Ring to answer on XX rings

## SET NUMBER OF REPEATS

The Set Number of Repeats command sets the number of times the Greeting message repeats. Valid numbers of repeats range from 00 to 15. If a user enters a valid number they hear the success beep and return to command mode ready to enter the next command. If the entered number is not valid the user hears the error tone and returns command mode ready to enter the next command.

Syntax... ( X X =any value 00 - 15)

- \* 1 6 # X X # Set Repeats

## SET MASTER PASSWORD

The Set Master Password command changes the unit's Master Password. Changing the Master Password prevents unauthorized access to command mode. **If you forget or lose your Master Password you will be unable to seize control of your unit, either remotely or locally, until the unit is refreshed. To refresh the MovieTimeS machine you must disconnect the power pack plug. Hold the MODE button (on the front panel) while re-applying power. Continue to hold the MODE button for 5 seconds after applying power to the unit.**

If the Set Master Password command is entered correctly the user hears the success beep and returns to command mode ready to enter the next command. If the entered password is not valid the unit hangs up.

Syntax... (X X X X = any value 0000 - 9999)

\* 9 2 # X X X X # Set Master Password

## MEMORY REQUEST

The Memory Request command allows the user to identify how much memory is installed in the system. If the command is correctly entered the user hears several beeps where each beep represents 1 installed memory chip, or 8 MB of memory. After the command has completed the unit returns to command mode ready to enter the next command.

Syntax...

\* 8 0 # Memory Request

## MEMORY TEST

The Memory Test command performs a diagnostic on the audio memory testing for errors. The Memory Test command erases all messages and resets the unit to the factory default settings. If the command is correctly entered the user hears the system busy signal for a period of time while the test is performed, followed by the success beep or error tone depending on the outcome of the test. After the command has completed the unit returns to command mode ready to enter the next command.

Syntax...

\* 8 1 # Memory Test

## RESTORE DEFAULT CONFIGURATION

The Restore Default Configuration command restores the unit to the factory defaults. This command erases all messages and brings the system to a fresh state which provides a good starting point for system configuration. If the command is correctly entered the user hears the system busy signal for a period of time while the units memory is erased, followed by the success beep, returning to command mode ready to enter the next command. See appendix C for a full listing of the default values. All messages are gone, and require re-recording.

Syntax:

\* 9 9 # Restore default configuration

## APPENDIX A

### MESSAGE CONFIGURATION

The following table shows the lengths for each available message.

16 Minute Memory Greeting Message	45 seconds
3 Information Messages	45 seconds each
Movie List Message	60 seconds
24 Screen Messages	30 seconds each

## APPENDIX B

### COMMAND SUMMARY

NAME	SYNTAX	RANGE	DESCRIPTION
Rings	* 1 1 X X#	01 -15	Sets number of rings to answer.
Message Record	*50 XX#	None	Records Messages 01-24 = Selections, 31 = Greeting, 32 = Selection List, 33-35 = Info.
Message Review	*60 XX#	None	Reviews Messages 01-24 = Screens, 31 = Greeting, 32 = Movie List, 33-35 = Info.
Message Delete	*70 XX#	None	Deletes Messages 01-24 = Selections, 31 = Greeting, 32 = Selection List, 33-35 = Info.
Memory Request	* 8 0 #	None	2 Beeps
Memory Test	* 8 1 #	None	Tests memory for errors.
Master Password	*92XXXX#		Sets the Master Password Where XXXX can be 0000-9999
Reset	* 9 9 #	None	Resets Unit to default settings

## APPENDIX C

### DEFAULT SETTINGS

This table lists the settings that your unit has when first powered up or after using the Restore Default Configuration command (99).

Rings	01
Repeats	0
Master Password	1234

## Suggestions for Recording Messages.

- Opening Greeting** You need to mention the name of the cinema and district (if you have multiple cinemas in the same town). Give the caller the options. We suggest you mention the touch tone number AFTER the option so they do not forget while listening to all options. Example: "For a list of movies we are playing, press 1."
- Movie List** This is always option 1. This message box leads to 24 screens with the show times. Add variety to your reading by rotating the lead-in to each movie. Example: "FOR Titanic, press 1. IF YOU WOULD LIKE TO SEE Blast from the Past, press 2. STARTING THE WEEK Payback, press 3. HELD OVER Private Ryan, press 4.... etc.  
Write down you own list of lead-ins to each movie so you can rotate them when making your recording for the week.
- Directions** Directions to the cinema can be an option message. This is valuable for first time visitors to your theatre. Regular customers do not need this information and would not access this option box.
- Ticket Pricing** Many cinemas have early-bird and senior citizens discounts. Also, movie club specials.

Extra: The 4 th box can be used for any special promotion or event. It could be used to announce coming attractions. Example: "Star Wars is coming to this theatre in May. Presented in digital sound with the new Center Surround 3X extended surround sound."

All options should be included in the opening greeting message. You may also want to list a special phone number for callers that do not have a touch-tone telephone.

## APPENDIX D

### SPECIFICATIONS

#### AUDIO

Encoding/Decoding	8 Bit U-LAW
Sampling Frequency	8Khz
Frequency Response	50 Hz to 3.5 kHz +/- 1.5 dB

#### MEMORY

Type	Flash
Size	8 Megabytes

#### MESSAGING

Number of Messages	29
Total Message Time	16 minutes

## CONNECTORS

Power	2.5mm Power Connector
Line 1 Telco	RJ-11 Type Modular Jack
Line 2 Telco	RJ-11 Type Modular Jack
Line 3 Telco	RJ-11 Type Modular Jack
Line 4 Telco	RJ-11 Type Modular Jack
Factory	RJ-45 Type Modular Jack
Program	RJ-11 Type Modular Jack

## TELCO INTERFACE

REN(in)	1.2b
Required Line	90V Ring, Loop Start

## POWER

Primary Input	12VdC @ 500mA
Source	117VAC, 60 Hz UL/CSA Listed Power Pack

## WALL MOUNTING THE MovieTimeS DIGITAL ANNOUNCER.

A plastic mounting plate and 2 self tapping screws are furnished with the MovieTimeS machine for wall mounting the product.

1. Screw the plate to the wall where you wish to mount the machine, making sure the plate is level.
2. Slip the two tracks on the back of the machine over the plate and allow the machine to drop to the bottom of the plate. Two tabs on the bottom of plate will hold the machine in place.
3. To remove the machine from the plate, push the machine up until it is free from the tabs.
4. Make sure no wires are trapped behind the machine.

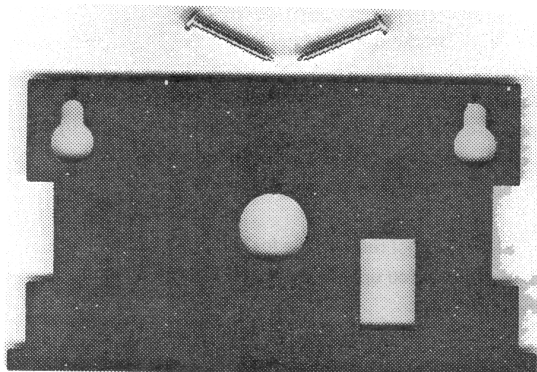

Mounting plate and screws



The machine should face UP with the line status LED's on the top.



## APPENDIX E

### CONTACTING SMART CUSTOMER SUPPORT

Only contact customer service if you are unable to resolve your problem through the dealer you purchased this unit from, and while you are able to review and make changes to the settings on the MovieTimeS you are experiencing problems with.

**NOTE: SMART customer service provides support for the MovieTimeS only. If you are experiencing problems with your phone system itself please refer your problem to the correct vendor.**

Customer service can be reached Monday through Friday at 800-45-SMART from 8:00 to 5:00 EST.

## APPENDIX F

### NOTICES & WARRANTY

#### FCC Notice

WARNING: This equipment HAS BEEN TESTED AND FOUND TO COMPLY WITH THE LIMITS FOR A CLASS A DIGITAL DEVICE PURSUANT TO PART 15 OF FCC RULES. THESE LIMITS ARE DESIGNED TO PROVIDE REASONABLE PROTECTION AGAINST HARMFUL INTERFERENCE WHEN THIS EQUIPMENT IS OPERATED IN A COMMERCIAL ENVIRONMENT. This equipment generates, uses, and can radiate radio frequency energy and, if not installed and used in accordance with the instruction manual, may cause harmful interference to radio communications. Operation of this equipment in a residential environment is likely to cause harmful interference in which case the user will be required to correct the interference AT HIS/HER OWN EXPENSE.

#### LIMITED WARRANTY

SMART devices, Inc. warrants that all equipment sold is free from defects in material and workmanship at the time of purchase. The warranty extends 2 years from the date of original purchase and covers parts and labor. If the defect is not the result of improper use, service, maintenance or installation, and if the equipment has not been otherwise damaged or modified after shipment, SMART or its authorized representative shall either replace or repair the defective equipment at SMART's option. After return of such equipment by buyer to SMART, or its representative, shipment shall be paid by the buyer. No credit shall be allowed for work performed by the buyer. Out-of-warranty repairs will be invoiced at the current SMART hourly rate plus the cost of parts, and shipping.

All implied warranties, if any, terminate two years from date of original purchase. SMART is not responsible for damage to other equipment or property or any other consequential incidental damage of any kind, whether based upon contract, negligence or strict liability. Maximum liability shall not, in any case, exceed the purchase price of the equipment.

The foregoing constitutes SMART's entire obligation with respect to this product. The original purchaser and user or owner shall have no other remedy and no claim for incidental or consequential damages. Some states do not allow limitations of how long an implied warranty lasts or do not allow the exclusion of incidental or consequential damages, therefore, the above limitations and exclusions may not apply to you.

This warranty gives specific legal rights. You may also have other rights, which may vary from state to state.

#### COPYRIGHT NOTICE

This manual is copyrighted. All rights reserved. This document may not, in whole or part, be copied, reproduced, reduced or translated by any means, either mechanical or electronic, without prior consent in writing from SMART Devices, Incorporated. The information in this manual has been carefully checked and is believed to be accurate. However, SMART assumes no responsibility for any inaccuracies that may be contained in this manual. In no event will SMART be liable for direct, indirect, special, incidental, or consequential damages resulting from any defect or omission in this manual, even if advised of the possibility of such damages.

In the interest of continued product development, SMART Devices, Inc reserves the right to make changes and improvements in this manual and the products it describes at any time, without notice or obligation.

@Copyright 2000 SMART Devices, Inc. 5945 Peachtree Corners East - Norcross, Georgia 30071 (800) 45-SMART

Printed in the U.S.A.

