

# FILM-TECH

**THE INFORMATION CONTAINED IN THIS ADOBE ACROBAT PDF FILE IS PROVIDED AT YOUR OWN RISK AND GOOD JUDGMENT.**

**THESE MANUALS ARE DESIGNED TO FACILITATE THE EXCHANGE OF INFORMATION RELATED TO CINEMA PROJECTION AND FILM HANDLING, WITH NO WARRANTIES NOR OBLIGATIONS FROM THE AUTHORS, FOR QUALIFIED FIELD SERVICE ENGINEERS.**

**IF YOU ARE NOT A QUALIFIED TECHNICIAN, PLEASE MAKE NO ADJUSTMENTS TO ANYTHING YOU MAY READ ABOUT IN THESE ADOBE MANUAL DOWNLOADS.**

**[WWW.FILM-TECH.COM](http://WWW.FILM-TECH.COM)**

# JSD-80

Cinema Processor

011001  
**USL, Inc.**  
Precision Sound • Light • Color

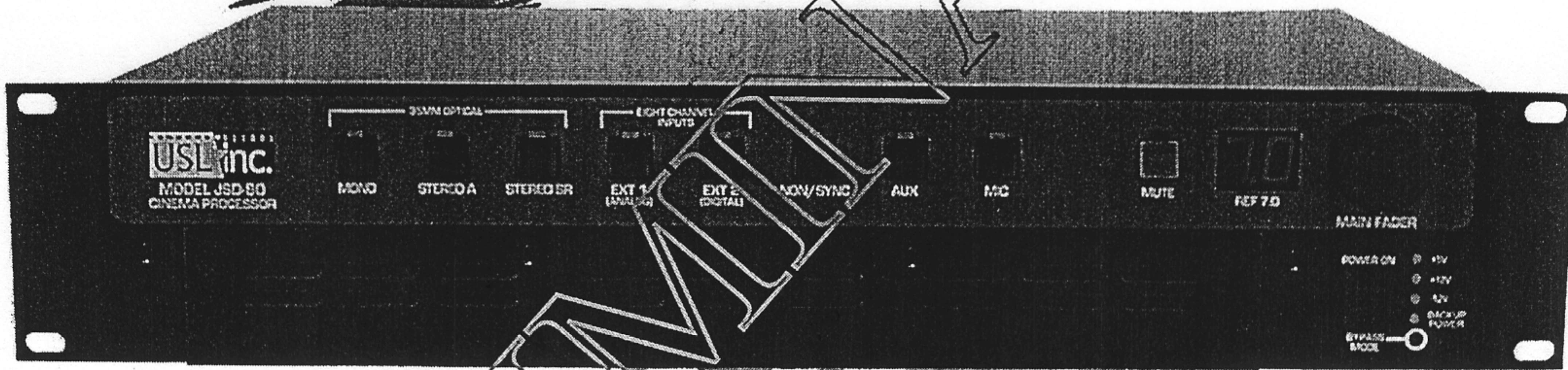

# INSTRUCTION MANUAL

Print Date: September 17, 2004**TABLE OF CONTENTS**

. Introduction.....	2	8. "A" Chain Alignment.....	18
1.1 Safety notice		8.1 Preparing the Soundhead	
1.2 Unpacking		8.2 Alignment of Solar Cell and Preamplifier	
1.3 The JSD-80 Overview		8.3 Sum and Difference Mode	
1.4 Technical Specifications		8.4 Mono EQ and Bypass Level	
1.5 Certifications		8.5 Optical Surround Gain and Delay	
2. Installation.....	6	8.6 Optical Subwoofer	
2.1 System Hardware Mounting and Grounding		8.7 Analog Non-Sync, Aux and Mic levels	
2.2 System Cooling and Ventilation		8.8 Digital Non-Sync, Digital Aux , and Digital 8 channel inputs	
3. Block Diagrams.....	7	8.9 Digital Time Delays	
3.1 Audio Block Diagram		9. "B" Chain Alignment.....	23
3.2 Two Channel Analog Inputs Block Diagram		9.1 Channel configuration	
3.3 Eight Channel Input Block Diagram		9.2 Headroom settings	
3.4 Control Block Diagram		9.3 Main channels	
4. System Modules.....	10	9.4 Subwoofer channel	
4.1 Input Module		9.5 Saving Settings After Alignment	
4.2 Output Module		10. Other Options.....	26
4.3 Control Module		10.1 Preset Format Levels	
5. Front Panel.....	11	10.2 Startup Mode	
5.1 Overview		10.3 Remote Fader	
5.2 Adjusting Format Levels		10.4 System Restore from Personality Module	
5.3 Adjusting Projector Gains		11. Trouble Shooting.....	27
6. Back Panel.....	12	12. Connector Pinouts.....	30
6.1 Rear Wiring Diagram			
6.2 Back Panel Input Connections			
6.3 Back Panel Signal Output Connections			
6.4 Other Back Panel Connections			
7. JSD-80 Interface Software.....	15		
7.1 Installation Procedure			
7.2 Opening screen			
7.3 Profile Screen			
7.4 Formats Screen			
7.5 Inputs Screen			
7.6 Equalizer Screen			
7.7 Outputs Screen			
7.8 Slit Eq Analyzer			
7.9 Creating, Saving and Loading Configuration Files			

## Section 1. Introduction

Please read the entire manual before beginning your installation.

### 1.1 Safety Notices

#### General Safety Summary European

Review the following safety precautions to avoid injury and prevent damage to this product. To avoid potential risk, use this product only as specified and only for the purpose described in the instruction manual.

#### To Avoid Fire and Personal Injury:

- Use Correct Power Cable. Use only the power cable provided. Ensure that the AC power outlet is located near the product and is easily accessible.
- Use a Correctly Grounded Power Source. The Power Supply earth ground is established through the ground conductor in the power cable. To avoid the potential of electric shock, the ground conductor must be correct.
- Observe Source Ratings. To avoid risk of fire or electric shock, the power source must be 100 - 240 VAC 50-60 Hz. (European Models)
- Do Not Operate with Suspected Failures. If you suspect there is damage or malfunction with this product, call the factory.
- Do Not Attempt Repair. Only a trained factory service person is authorized to repair this product.
- Do Not Operate this Product Near Heat Sources. This product should not be located near heat sources such as radiators, heat registers, or stoves.
- Provide Proper Ventilation. The operating temperature range is between 0° C and 40° C. The humidity range is between 20% and 80%, non-condensing. The cooling method is by convection.
- Keep Product Surfaces Clean and Dry. Disconnect the power cable from the power source before cleaning. Do not use liquid cleaners or aerosol cleaners. Use a damp cloth for cleaning.
- Do Not Push Objects Into Opening of this Product. Never insert objects into the product through openings.
- Do Not Operate In Wet or Damp Conditions.

- Do Not Operate In an Explosive Atmosphere.
- Prevent the Spilling of Liquids onto the System Components.
- Inspect the power cable and all cables prior to use. Confirm that the power cable and other interconnecting cables are free from damage.

#### Safety Standard

The EN 60950 standard specifies safety design requirements that reduce or eliminate the risk of personal injury to both the product user and service personnel. This product is designed and tested to meet the standards of the International Electrotechnical Commission (IEC) European Norm EN 60950, IEC 50950 (The Standard for Information Technology Equipment Including Electrical Business Equipment).

## Le Résumé de la Sécurité général Européen

Examinez les précautions de la sécurité suivantes éviter la blessure et prévenir le dégât à ce produit. Éviter le risque potentiel, utilisez ce produit seulement comme a spécifié et seulement car le but a décrit dans le manuel d'instructions.

### Éviter Feu et Blessure Personnelle:

- Utilisez le Câble du Pouvoir Correct. Utilisez seulement le câble du pouvoir fourni. Assurez que les AC font fonctionner le débouché est localisé près le produit et est accessible facilement.
- Utilisez une Source du Pouvoir Correctement Fondée. La terre du monde de la Provision du Pouvoir est établie à travers le conducteur moulu dans le câble du pouvoir. Éviter le potentiel de choc électrique, le conducteur moulu doit être correct.
- Observez des Estimations de la Source. Pour éviter risque de feu ou choc électrique, la source du pouvoir doit être 100-240 VAC 50-60 Hz..
- N'opérez pas ce Produit avec Toutes Clôtures Ouvertes ou Enlevez.
- Évitez l'Ensemble de circuits Exposé. N'entreprenez pas ouvrir la Provision du Pouvoir parce que sa certification de la sécurité serait invalidée. La Provision du Pouvoir est un appareil scellé non-réparable.
- N'opérez pas avec les Échecs Suspects. Si vous suspectez il y a le dégât ou mal fonctionner avec ce produit, appelez l'usine.
- N'entreprenez pas Réparation. Seulement une personne du service de l'usine compétente est autorisée pour réparer ce produit.
- N'opérez pas ce Produit Sources de la Chaleur Proches. Ce produit ne devrait pas être localisé de sources de la chaleur proches tel que radiateurs, registres de la chaleur, poêles, ou amplificateurs.
- Fournissez Ventilation Adéquate. La température du fonctionnement devrait être entre 0° C et 40° C. L'humidité devrait être 20% et 80%. La méthode refroidissante est par convection et un ventilateur interne.
- Gardez les Surfaces du Produit Nettoient et Sec. Déconnectez le câble du pouvoir de la source du pouvoir avant de nettoyer. N'utilisez pas de nettoyeurs liquides ou de nettoyeurs de l'aérosol. Utilisez un

tissu humide pour nettoyer.

- Ne poussez pas d'Objets Dans Ouvrir de ce Produit. Jamais objets de l'encart dans le produit à travers ouvertures.
- N'opérez pas Dans les Conditions Mouillées ou humides.
- N'opérez pas Dans une Atmosphère Explosive.
- Prévenez le Répandre des Liquides sur les Composants du Système.
- Inspectez le câble du pouvoir et tous les câbles antérieur à usage. Confirmez que le câble du pouvoir et autres interconnectant câbles sont libres de dégât.

### Le Niveau de la sécurité

L'EN 60950 niveau spécifie exigences du dessin de la sécurité qui réduisent ou éliminent le risque de blessure personnelle à l'utilisateur du produit et personnel du service. Ce produit est conçu et est testé pour satisfaire aux niveaux de l'Electrotechnical Commission International (IEC) Norm Européen EN 60950, IEC 60950 (Le Niveau pour Matériel de la Technologie de l'Information qui Inclut le Matériel de l'Affaire Électrique).

## Allgemeine Sicherheit-Zusammenfassung Europäisch

Überprüfen Sie die folgend Sicherheit-Vorkehrungen, Verletzung zu vermeiden und Schaden zu diesem Produkt zu verhindern. Um potentiell Risiko zu vermeiden, benutzen Sie dieses Produkt nur als vorgeschrieben hat und nur denn der Zweck beschrieb in der Bedienungsanleitung.

### Um Feuer und Persönliche Verletzung zu vermeiden:

- Benutzen Sie Korrektes Macht-Kabel. Benutzen Sie nur das Macht-Kabel, das bereitgestellt wurde. Stellen Sie sicher, daß der WECHSELSTROM-Macht-Abfluß in der Nähe vom Produkt gefunden wird und leicht zugänglich ist.
- Benutzen Sie eine Korrekt geerdet Macht-Quelle. Der Macht Versorgung Erde Boden wird durch den Boden-Schaffner im Macht-Kabel gegründet. Das Potential elektrischen Schocks zu vermeiden muß der Boden-Schaffner korrekt sein.
- Beobachten Sie Quelle-Klassen. Risiko von Feuer oder elektrischem Schock zu vermeiden muß die Macht-Quelle 100 sein-240 VAC 50-60- Hz.
- Operieren Sie dieses Produkt mit Irgendwelchen Gehegen nicht, die geöffnet wurden, oder entfernen Sie.
- Vermeiden Sie Ungeschützten Schaltkreise. Versuchen Sie, die Macht-Versorgung zu öffnen nicht, weil seine Sicherheit-Zulassung ungültig gemacht werden würde. Die Macht-Versorgung ist ein nicht-reparierbares luftdicht verschlossene Gerät.
- Operieren Sie mit verdächtig Mißerfolgen nicht. Wenn Sie verdächtigen, gibt es Schaden oder Funktionsstörung mit diesem Produkt, rufen Sie die Fabrik.
- Versuchen Sie keine Reparatur. Nur eine erzogen Fabrik-Dienst-Person wird ermächtigt, dieses Produkt zu reparieren.
- Operieren Sie dieses Produkt Nahe Hitze-Quellen nicht. Dieses Produkt sollte keine nahe Hitze-Quellen wie Heizkörper, Hitze-Register, Herde, oder Verstärker gefunden werden.
- Stellen Sie Richtige Belüftung bereit. Die operierend Temperatur sollte zwischen 0° C und 40° C. Die

Luftfeuchtigkeit sollte sein 20% und 80%. Die erfrischend Methode ist durch Konvektion und einen innereren Fächer.

- Bleiben Sie, Produkt-Oberflächen reinigen und Trocken. Trennen Sie das Macht-Kabel von der Macht-Quelle vor dem Reinigen. Benutzen Sie keine flüssige Reiniger oder Aerosol-Reiniger. Benutzen Sie einen klammen Stoff für das Reinigen.
- Schieben Sie keine Gegenstände Ins Öffnen von diesem Produkt. Nie Beifügung-Gegenstände ins Produkt durch Öffnungen.
- Operieren Sie In Nassen oder Klammen Zuständen nicht.
- Operieren Sie In einer Explosiven Atmosphäre nicht.
- Verhindern Sie das Verschütten von Flüssigkeiten auf die System-Bestandteile.
- Inspizieren Sie das Macht-Kabel und alle Kabel vorausgehend zu Verwendung. Bestätigen Sie, daß das Macht-Kabel und andere verbindend Kabel frei von Schaden sind.

### Sicherheit-Standard

Der EN 60950 Standard schreibt Sicherheit-Entwurf-Anforderungen vor, der reduzieren oder das Risiko persönlicher Verletzung zu sowohl dem Produkt-Benutzer als auch Dienst-Personal ausschließen. Dieses Produkt wird entworfen und wird geprüft, um den Standards vom Internationalen Electrotechnical Commission zu entsprechen (IEC) europäischer Norm EN 60950, IEC 60950 (Der Standard für Informationen-Technologie-Ausrüstung, die Elektrische Unternehmen-Ausrüstung einschließt,).

## 1.2 Unpacking

Unpack the unit carefully. If the container has been damaged, thoroughly inspect the equipment to make certain there is no hidden damage. File a claim immediately with the carrier if any damage is found. Also advise your dealer or the factory.

The box should include the following items. If anything is missing, notify your dealer or the factory:

- JSD-80 Chassis
- Power Supply cable
- Backup Power Supply
- Screw-terminal plugs (4)
- DB-9 connectors (2)
- EMI Filters, Clamp On Style (3)
- CD with PC Host program
- Instruction Manual

### 1.3 The JSD-80 Overview

Ultra Stereo has combined its vast experience with conventional analog theater sound systems with state of the art digital signal processing technology. The result: The JSD-80, which we believe to be the finest surround decoder available today. Some of the standard features include:

- Dual stereo projector inputs with low-noise preamplifiers, individual gain and high-frequency boost controls, and emergency backup circuitry.
- Stereo line level inputs for Non-Sync (with fade-in), plus an Auxiliary input.
- The Microphone input is for public address use.
- 100 % digital "A" and "SR" type noise reduction that emulates the analog standards.
- Eight "discrete" analog inputs for interfacing to existing digital format 35mm film decoders.
- 1/3 octave equalization on ALL channels except subwoofer.
- Advanced automation features including level settings for each format.
- Built in Personality Module contains a backup copy of all settings which can be used to restore the system.

The JSD-80 unit includes all of the above features in every unit. All units come with an international power supply and a backup power supply.

- Optional 8 channel AES-EBU digital inputs for interfacing to digital sources.
- Optional Bitstream decoder with 2 SPDIF inputs.

This manual contains information on the installation, set-up, and operation of the JSD-80 Cinema Processor. Also included is fundamental information on alignment of projector soundheads.

### 1.4 Technical Specifications:

Rack-mount chassis frame construction with plug-in modules accessible behind removable front panel.

#### Signal Connections

- a. Standard 9 pin D-type female connectors for: Projector 1, Projector 2, Mic, and RS-232 communications port.
- b. Standard 25 pin D-type female connectors for Analog 8

channel Input (Ext1), Digital 8 channel (Ext 2) and automation I/O.

- c. Standard 25 pin D-type Male for Monitor output.
- d. Detachable screw terminal connectors are used for Automation inputs, Hearing Impaired output, Line outputs, Changeover pulse, Remote fader and Mute.
- e. RCA jacks are used for Non/Sync and Aux input

#### Signal Inputs

a. Projector Inputs:  
Voltage: 0.35 mV nominal  
Impedance: 360 Ohms  
Voltage adjustment: -23.9 to +11.9dB (.35 mV to 20mV)  
High Frequency Slit EQ: 10 kHz to 32 kHz

b. Non-Sync Input:  
Voltage: 300 mV RMS  
Impedance: 30 k Ohms  
Voltage adjustment: -24 to +6 dB (150-750mv)

c. Auxiliary Input:  
Voltage: 300 mV RMS  
Impedance: 30 k Ohms  
Voltage adjustment: -23.9 to +11.9 dB (75mV-1.2V)

d. Microphone Input:  
Impedance (mic): 2 k Ohms  
Voltage adjustment: -23.9 to +11.9 dB (.8-12mV)

e. Analog 8 channel Input:  
Voltage: 300 mV RMS  
Impedance: 30 k Ohms  
Voltage adjustment: None

f. Digital Input:  
Eight channels AES-EBU @32-96 kHz, 24 bit sample rate.

#### Line Outputs:

Voltage: 24 mV to 750 mV (nominal: 300mV)  
Impedance: < 500 Ohms  
Gain Adjustment: -22 dB to +8 dB  
Hearing Impaired Outputs: 500 Ohms impedance  
Nominal level: 300mVrms: sum of L,C & R with left and right channels lowered 3dB.

#### Audio Signal Paths

Headroom: 26 dB (with EQ flat), 20 dB typical with 6dB EQ boost)  
S/N Ratio: 80 dB A weighted  
EQ (subwoofer): one parametric adjustable from 20 Hz to 100 Hz  
EQ bands (all other): 27 1/3-octave bands from 40 Hz

to 16 kHz  
EQ level adjustment: +/-6 dB  
Bass and Treble adjustable +/-6db

### Automation Inputs:

Active low, momentary dry contact closures. Automation common is connected to signal ground inside the JSD-80 through a 10 Ohm resistor (to minimize ground loop problems).

### Automation Outputs (DB25):

Active low. Recommended indicator circuit is a standard LED with a 1k series resistor connected between 5V and the automation status line. (see section 12)

### Power Input:

100-240vac 50-60hz @360mA.

## 1.5 Declaration of Conformance, CE

JSD-80, Cinema Sound Processor  
EC Declaration of Conformity

Meets intent of Directive 89/336/EEC for Electromagnetic Compatibility and Low-Voltage Directive 73/23/EEC for Product Safety. Compliance was demonstrated to the following specifications as listed in the Official Journal of the European Communities:  
EN 55022 Conducted Emissions, EN 55022 Radiated Emissions: Class A Limits

EN 55024 Immunity:  
EN61000-4-2 Electrostatic Discharge Immunity  
EN61000-4-3 RF Electromagnetic Field Immunity  
EN61000-4-4 Electrical Fast Transient/Burst Immunity  
EN61000-4-5 Power Line Surge Immunity  
IEN61000-4-6 Conducted RF Immunity  
EN61000-4-7 Voltage Dips, Short Interruptions and Variations

## Certifications

Low Voltage Directive 73/23/EEC:  
EN EN60950 Information Technology, Video And similar Electronic apparatus  
Safety Requirements IEC 60950  
CE, UL, cUL Safety and Overall Compliance

VDE Certified Power Cords

Pollution  
Not intended for environments where conductive pollutants may be present

## Equipment Class

Class III Equipment: Equipment in which protection against electrical shock relies upon supply from SELV circuits (Safety Transformer) and in which hazardous voltages are not generated. Insulation and protective fusing are used in addition to these criteria.

Equipment Type A: Equipment that is intended for connection to the building power supply wiring via non-industrial plugs and sockets or via appliance couplers or both.

## Section 2: Installation

### 2.1 System Hardware Mounting and Grounding

The JSD-80 is designed to mount in a standard 19" rack, and is two standard rack spaces (3-1/2") high. We recommend blank panels above and below whenever space permits. Mounting the unit immediately above a major heat producing component (like a power amplifier) is not recommended. The JSD-80 includes a three-prong grounding plug and a three-wire power cord to accommodate a safe ground path from the chassis to the electrical system ground. Defeating this ground by removing the ground prong is not recommended.

### 2.2 System Cooling and Ventilation

#### Important

Care should be taken to insure the JSD-80 has adequate ventilation for cooling during operation. It is recommended that one rack space below the JSD-80 is left open to allow outside air circulation through the unit. A ventilation panel, USL, Inc. part number VP-1, is recommended for projection booths where the normal ambient temperature exceeds specified equipment operating temperatures listed in the safety section of this manual. Also, it is recommended that equipment with no more than a nine inch depth be mounted directly above the JSD-80 to insure adequate airflow through the unit's rear ventilation slots.



Section 3: Block Diagrams

3.1 AUDIO BLOCK DIAGRAM

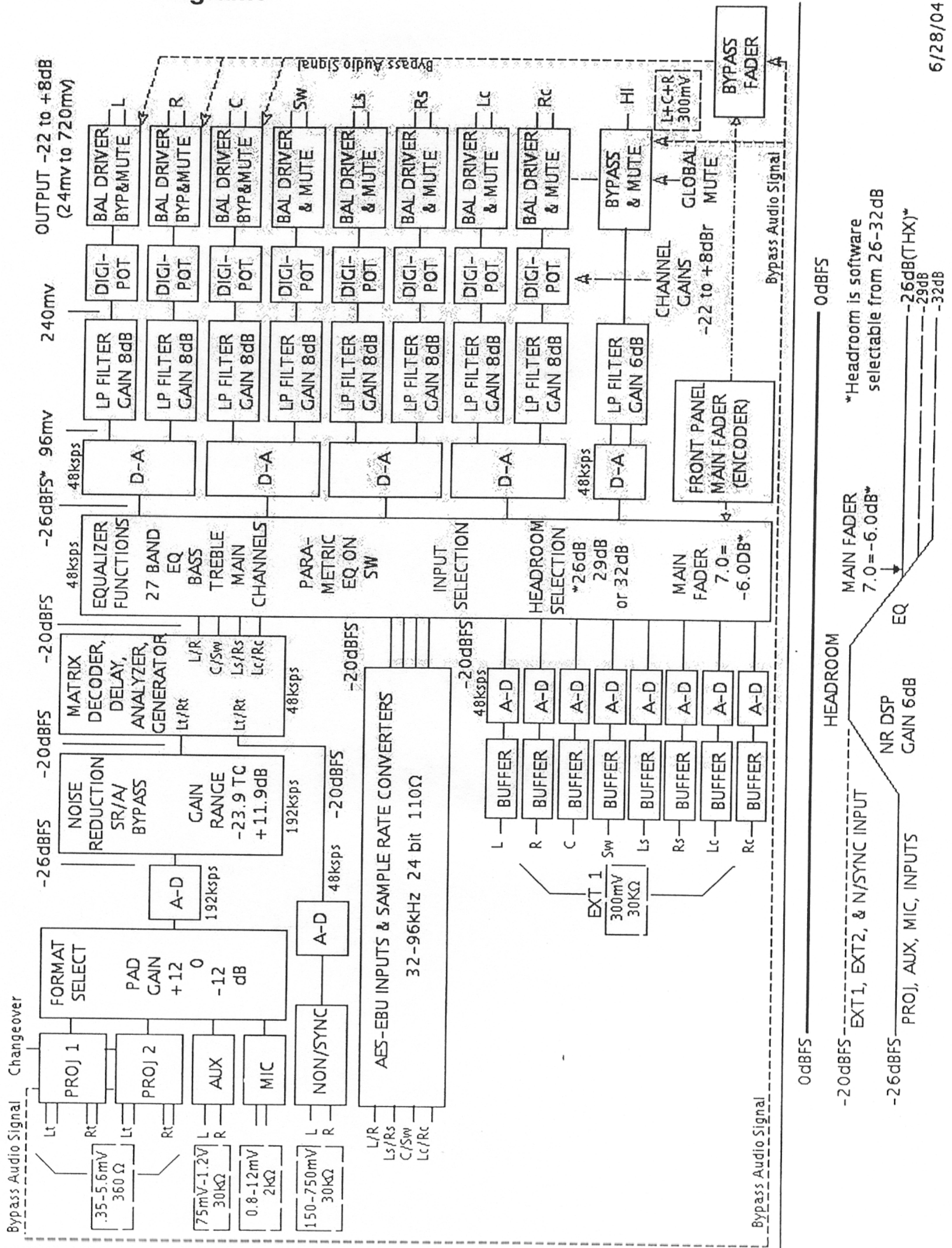

6/28/04

### 3.2 Two Channel Analog Input Block Diagram

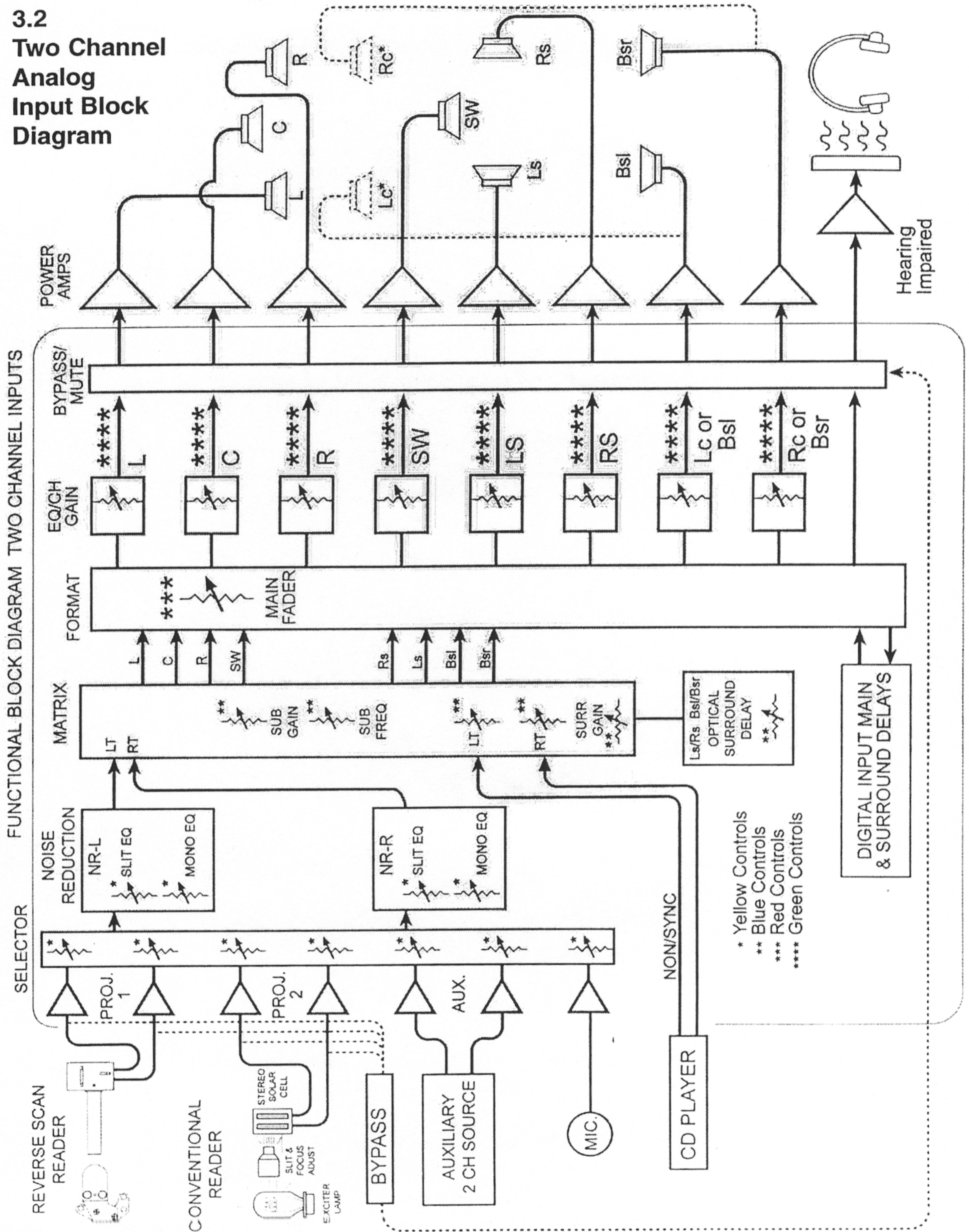

**JSD-80 PROCESSOR**