

# FILM-TECH

**THE INFORMATION CONTAINED IN THIS ADOBE ACROBAT PDF FILE IS PROVIDED AT YOUR OWN RISK AND GOOD JUDGMENT.**

**THESE MANUALS ARE DESIGNED TO FACILITATE THE EXCHANGE OF INFORMATION RELATED TO CINEMA PROJECTION AND FILM HANDLING, WITH NO WARRANTIES NOR OBLIGATIONS FROM THE AUTHORS, FOR QUALIFIED FIELD SERVICE ENGINEERS.**

**IF YOU ARE NOT A QUALIFIED TECHNICIAN, PLEASE MAKE NO ADJUSTMENTS TO ANYTHING YOU MAY READ ABOUT IN THESE ADOBE MANUAL DOWNLOADS.**

**[WWW.FILM-TECH.COM](http://WWW.FILM-TECH.COM)**

MANUFACTURING  
NUMBERS:

9300300  
9300302  
9300304  
9300306  
9300308  
9300309  
9300320  
9300321  
9300322  
9300324  
9300330  
9300331  
9300332  
9300334  
9300336  
9300376  
9300340  
9300341  
9300342  
9300344  
9300350  
9300351  
9300352  
9300356  
9300360  
9300374  
9300376  
9300380



**Antunes Foodservice Equipment**  
DIVISION OF A.J. ANTUNES & CO. · ISO 9001 CERTIFIED

A BRAND OF A.J. ANTUNES & CO.  
**roundup**  
ANTUNES FOODSERVICE EQUIPMENT

# **HOT DOG CORRAL**

**Model HDC**  
**Series 9300000**



P/N 1010609 Rev. F 03/04



# **Owner's Manual**

**TABLE OF CONTENTS**

<b>Owner Information</b> .....	<b>2</b>	<b>Operation</b> .....	<b>9</b>
General .....	2	General .....	9
Warranty Information .....	2	Operating Instructions .....	9
Service/Technical Assistance .....	3	Cleaning .....	10
<b>Important Safety Information</b> .....	<b>3</b>	<b>Maintenance</b> .....	<b>10</b>
Electrical Ratings.....	5	Inspecting and Aligning Drive Parts .....	10
Electrical Cord & Plug Configurations .....	5	Replacing the Black Nylon Glides .....	11
<b>Specifications</b> .....	<b>5</b>	Hot Dog Corral Technical Theory of Operation .....	12
Capacities (Refrigerated Product Only–Not Frozen).....	5	<b>Technical Theory of Operation</b> .....	<b>12</b>
Dimensions .....	6	<b>Troubleshooting</b> .....	<b>13</b>
Unpacking.....	7	<b>Replacement Parts</b> .....	<b>14</b>
Equipment Setup .....	7	<b>Wiring Diagrams</b> .....	<b>19</b>
<b>Installation</b> .....	<b>7</b>	LIMITED WARRANTY .....	20
Food Shield (Optional) .....	8		

**OWNER INFORMATION**

**General**

The Roundup Hot Dog Corral is a unique and innovative way to grill hot dogs. The hot dogs are placed in a “corral” that moves up-and-down over a heated flat grill surface. The corral motion allows the hot dogs to turn. As the hot dogs turn, they roll in their own juices, producing a self-basting hot dog that sears in all the natural flavor.

The versatile Hot Dog Corral will accommodate any size hot dog along with Polish sausage, bratwurst and breakfast sausage.

This manual provides the safety, installation and operating procedures for the Hot Dog Corral. We recommend that all information contained in this manual be read prior to installing and operating the unit.

Your Hot Dog Corral is manufactured from the finest materials available and is assembled to Roundup’s strict quality standards. This unit has been tested at the factory to ensure dependable trouble-free operation.

**Warranty Information**

Please read the full text of the Limited Warranty in this manual.

If the unit arrives damaged, contact the carrier immediately and file a damage claim with them. Save all packing materials when filing a claim. Freight damage claims are the responsibility of the purchaser and **are not** covered under warranty.

The warranty **does not extend to:**

- Damages caused in shipment or damage as result of improper use.
- Installation of electrical service.
- Normal maintenance as outlined in this manual.
- Malfunction resulting from improper maintenance.
- Damage caused by abuse or careless handling.
- Damage from moisture into electrical components
- Damage from tampering with, removal of, or changing any preset control or safety device.

**IMPORTANT! Keep these instructions for future reference.  
If the unit changes ownership, be sure this manual accompanies the equipment.**

## OWNER INFORMATION (continued)

### Service/Technical Assistance

If you experience any problems with the installation or operation of your unit, contact your local Roundup Authorized Service Agency.

Fill in the information below and have it handy when calling your authorized service agency for assistance. The serial number is on the specification plate located on the unit.

Purchased From: \_\_\_\_\_

Date of Purchase: \_\_\_\_\_

Model No.: \_\_\_\_\_

Serial No.: \_\_\_\_\_

Mfg. No.: \_\_\_\_\_

Refer to the service agency directory included with your unit.

Authorized Service Agency

Name: \_\_\_\_\_

Phone No.: \_\_\_\_\_

Address: \_\_\_\_\_

Use only genuine Roundup replacement parts in this unit. Use of replacement parts other than those supplied by the manufacturer will void the warranty. Your Authorized Service Agency has been factory trained and has a complete supply of parts for this toaster.

You may also contact the factory at **1-877-392-7854** (toll Free in the U.S.) or **630-784-1000** if you have trouble locating your local Authorized Service Agency.

## IMPORTANT SAFETY INFORMATION

Throughout this manual, you will find the following safety words and symbols that signify important safety issues with regards to operating or maintaining the equipment.

### **WARNING**

**GENERAL WARNING.** Indicates information important to the proper operation of the equipment. Failure to observe may result in damage to the equipment and/or severe bodily injury or death.

### **WARNING**

**ELECTRICAL WARNING.** Indicates information relating to possible shock hazard. Failure to observe may result in damage to the equipment and/or severe bodily injury or death.

### **CAUTION**

**GENERAL CAUTION.** Indicates information important to the proper operation of the equipment. Failure to observe may result in damage to the equipment.

### **WARNING**

**HOT SURFACE WARNING.** Indicates information important to the handling of equipment and parts. Failure to observe caution could result in personal injury.

## IMPORTANT SAFETY INFORMATION (continued)

In addition to the warnings and cautions in this manual, use the following guidelines for safe operation of the unit.

- Read all instructions before using equipment.
- For your safety, the equipment is furnished with a properly grounded cord connector. Do not attempt to defeat the grounded connector.
- Install or locate the equipment only for its intended use as described in this manual. Do not use corrosive chemicals in this equipment.
- Do not operate this equipment if it has a damaged cord or plug, if it is not working properly, or if it has been damaged or dropped.
- This equipment should be serviced by qualified personnel only. Contact the nearest Roundup authorized service facility for adjustment or repair.
- Do not block or cover any openings on the unit.
- Do not immerse cord or plug in water.
- Keep cord away from heated surfaces.
- Do not allow cord to hang over edge of table or counter.

The following warnings and cautions appear throughout this manual and should be carefully observed.

- Turn the unit off, disconnect the power source and allow unit to cool down before performing any service or maintenance on the unit.
- The procedures in this chapter may include the use of chemical products. These chemical products will be highlighted with bold face letters followed by the abbreviated HCS (Hazard Communication Standard). See Hazard Communication Standard manual for the appropriated Material Safety Data Sheets (MSDS).
- The unit should be grounded according to local electrical codes to prevent the possibility of electrical shock. It requires a grounded receptacle with separate electrical lines, protected by fuses or circuit breaker of the proper rating.
- All electrical connections must be in accordance with local electrical codes and any other applicable codes.

- **WARNING ELECTRICAL SHOCK HAZARD. FAILURE TO FOLLOW THESE INSTRUCTIONS COULD RESULT IN SERIOUS INJURY OR DEATH.**
  - Electrical ground is required on this appliance.
  - Do not modify the power supply cord plug. If it does not fit the outlet, have a proper outlet installed by a qualified electrician.
  - Do not use an extension cord with this appliance.
  - Check with a qualified electrician if you are in doubt as to whether the appliance is properly grounded.
- This equipment is to be installed to comply with the basic plumbing code of the Building Officials and Code Administration, Inc. (BOCA) and the Food Service Sanitation Manual of the Food and Drug Administration (FDA).
- Do not clean this appliance with a water jet.
- Do not use a sanitizing solution or abrasive materials. The use of these may cause damage to the stainless steel finish.
- Chlorides or phosphates in cleansing agents (e.g. bleach, sanitizers, degreasers or detergents) could cause permanent damage to stainless steel equipment. The damage is usually in the form of discoloration, dulling of metal surface finish, pits, voids, holes or cracks. This damage is permanent and not covered by warranty.
- The following tips are recommended for maintenance of your stainless steel equipment.
  - Always use soft, damp cloth for cleaning, rinse with clear water and wipe dry. When required, always rub in direction of metal polish lines.
  - Routing cleaning should be done daily using soap, ammonia detergent and water.
  - Stains and spots should be sponged using a vinegar solution as required.
  - Finger marks and smears should be rubbed off using soap and water.
  - Hard water spots should be sponged using a vinegar solution.

## SPECIFICATIONS

### Electrical Ratings

Model	Voltage	Watts	Amps	Hertz
HDC-20	120	1000	8.3	50/60
	230	1000	4.3	50/60
HDC-21A	210	1000	8.3	50/60
	230	1250	5.4	50/60
HDC-30A	120	1500	12.5	50/60
	230	1500	6.5	50/60
HDC-35A	120	1750	14.5	50/60
	230	1750	7.6	50/60
HDC-50A	120	1750	14.5	50/60
	230	1750	7.6	50/60

### Electrical Cord & Plug Configurations

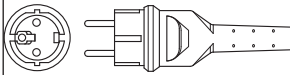
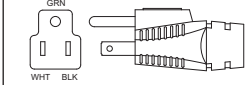
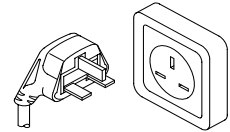
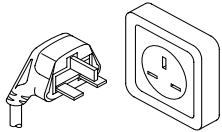
Letter Code*	Description	Configuration
C	Commercial Cord	
H	Harmonized Cord	
(H)C***	CEE 7/7, 16 Amp., 250 VAC (Assembly Only).	
(C)F**	5-15P, 15 Amp., 120 VAC., Non – Locking (Assembly Only).	
G	BS-1363 13 Amp, 250 VAC	

### ⚠ CAUTION ⚠

All electrical connections must be in accordance with local electrical codes and any other applicable codes.

### ⚠ WARNING ⚠

**ELECTRICAL SHOCK HAZARD. FAILURE TO FOLLOW THE INSTRUCTIONS IN THIS MANUAL COULD RESULT IN SERIOUS INJURY OR DEATH.**

- Electrical ground is required on this appliance.
- Do not modify the power supply cord plug. If it does not fit the outlet, have a proper outlet installed by a qualified electrician.
- Do not use an extension cord with this appliance.
- Check with a qualified electrician if you are in doubt as to whether the appliance is properly grounded.

### Capacities

(Refrigerated Product Only—Not Frozen)

Model	At One Time	Per Hour
HDC-20	4-to-a-pound 7" Hot Dogs	
	20	200
HDC-21A	4-to-a-pound 7" Hot Dogs	
	21	210
HDC-30A	4-to-a-pound 7" Hot Dogs	
	30	300
HDC-35A	4-to-a-pound 7" Hot Dogs	
	35	350
HDC-50A	4-to-a-pound 7" Hot Dogs	
	50	500

**SPECIFICATIONS (continued)**

**Dimensions**

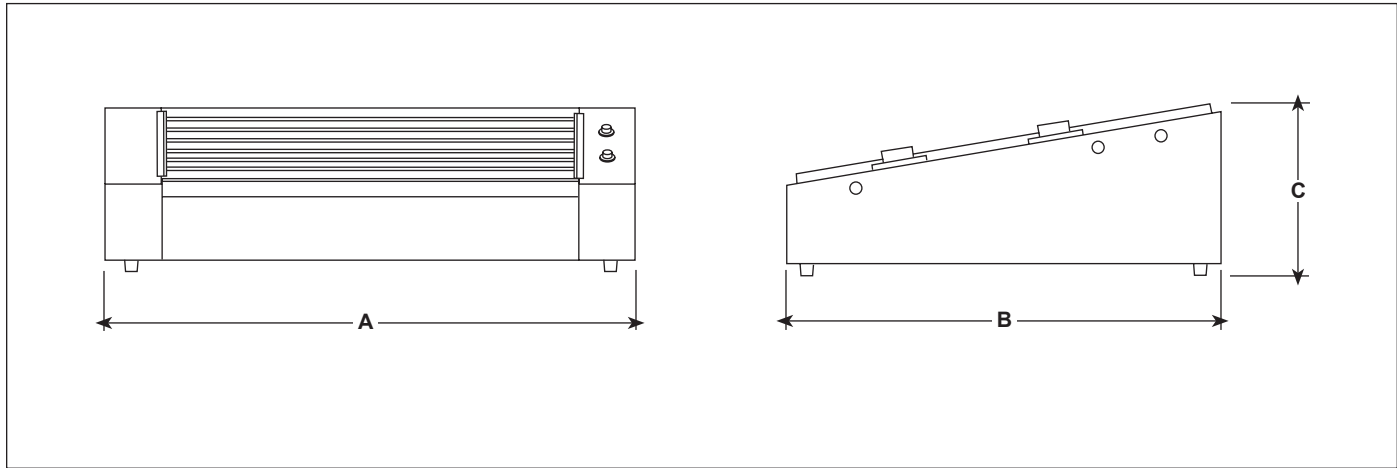

<b>Model</b>	<b>Width (A)</b>	<b>Depth (B)</b>	<b>Height (C)</b>	<b>Shipping Weight</b>
HDC-20	18-3/4" (476 mm)	21" (533 mm)	8-1/2" (216 mm)	45 lbs. (20 kg)
HDC-21A	22-7/8" (581 mm)	15-1/4" (387 mm)	7-1/4" (184 mm)	38 lbs. (17.2 kg)
HDC-30A	22-7/8" (581 mm)	20-5/8" (524 mm)	7-1/4" (184 mm)	48 lbs. (21.2 kg)
HCD-35A	33-3/8" (848 mm)	15-1/4" (387 mm)	7-1/4" (184 mm)	54 lbs. (24.5 kg)
HDC-50A	33-3/8" (848 mm)	20-5/8" (524 mm)	7-1/4" (184 mm)	70 lbs. (31.75 kg)

### INSTALLATION

#### Unpacking

1. Remove unit and all packing materials from shipping carton.
2. Open the large box. Remove all packing materials and protective coverings from the unit and parts.

**NOTE: If any parts are missing or damaged, contact Antunes Technical Service IMMEDIATELY at 1-800-253-2991.**

3. Wash driver frame in soap and water. Wipe all surfaces of the unit with a hot damp cloth.

**NOTE: Do not use a dripping wet cloth. Wring out before use.**

4. Install driver frame onto unit.

#### Equipment Setup

When placing the unit into service, pay attention to the following guidelines.

- Make sure power to the unit is off and the unit is at room temperature.
- Do not block or cover any openings on the unit.
- Do not immerse cord or plug in water.
- Keep cord away from heated surfaces.
- Do not allow cord to hang over edge of table or counter.
- Place unit on a sturdy, level table or work surface.

Ensure that the line voltage corresponds to the stated voltage on the unit specification label.

Turn the Rocker Switch (power On/Off) to OFF. Connect the unit to the power supply.

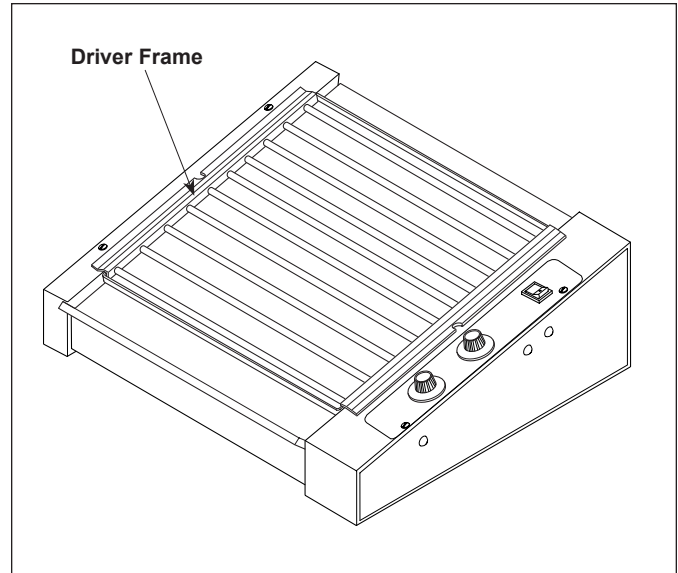

Figure 1. Hot Dog Corral

#### ⚠ CAUTION ⚠

All electrical connections must be in accordance with local electrical codes and any other applicable codes.

#### ⚠ WARNING ⚠

**ELECTRICAL SHOCK HAZARD. FAILURE TO FOLLOW THE INSTRUCTIONS IN THIS MANUAL COULD RESULT IN SERIOUS INJURY OR DEATH.**

- Electrical ground is required on this appliance.
- Do not modify the power supply cord plug. If it does not fit the outlet, have a proper outlet installed by a qualified electrician.
- Do not use an extension cord with this appliance.
- The unit should be grounded according to local electrical codes to prevent the possibility of electrical shock. It requires a grounded receptacle with separate electrical lines, protected by fuses or circuit breaker of the proper rating.
- Check with a qualified electrician if you are in doubt as to whether the appliance is properly grounded.



## INSTALLATION (continued)

### Food Shield (Optional)

**NOTE: Early style corrals do not have weldnuts on inside of side covers. When installing the food shield, jamnuts (5, figure 2) must be used.**

1. Turn the Rocker Switch (power On/Off) to OFF and unplug the power cord.
2. Assemble the hardware to the left and right cover panels as shown in Figure 2.
3. If a non-pivoting food shield is desired, follow Installation A. If a pivoting food shield is desired, use Installation B.

Item	Part No.	Description	Qty.
1	2120121	Spacer	2
2	3080158	Screw, Pan Hd., #8-32 x 5/8"	2
3	3250104	Washer, Flat, SS, 1/4"	2
4	3250169	Shoulder Bolt, Socket Hd., 5/16 x 1/2"	4
5	325P135	Jamnut, 1/4-20 (early style units only)	4
6	1150104	Allen Wrench (not shown)	1

**NOTE: SG-21 & SG-35 shown. SGH-20 uses same mounting, but is shaped differently.**

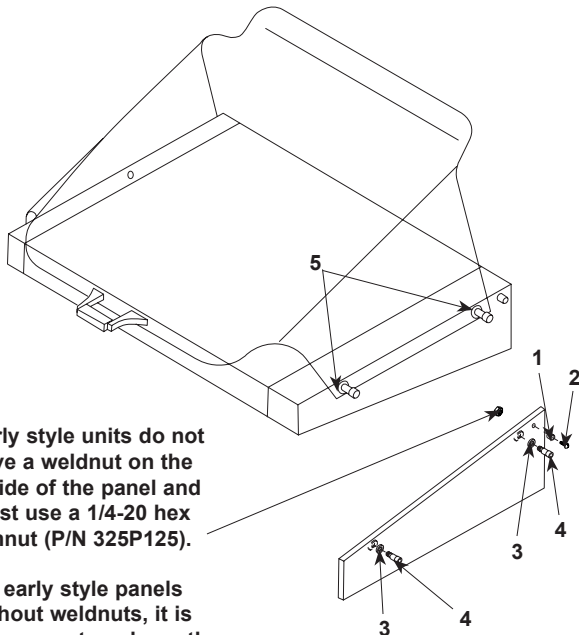

Early style units do not have a weldnut on the inside of the panel and must use a 1/4-20 hex jamnut (P/N 325P125).

On early style panels without weldnuts, it is necessary to enlarge the mounting holes to accept the 1/4-20 shoulder bolts.

### Installation A—Non-pivoting

Install shoulder bolts through all mounting holes in food shield.

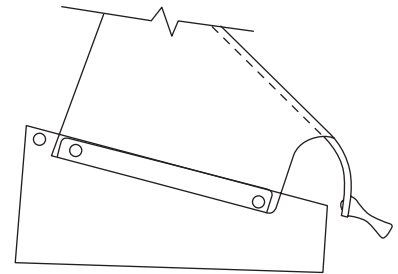

### Installation B—Pivoting

Rear Pivot - Install rear shoulder bolts through mounting holes in food shield. Front of shield rests on top of shoulder bolts.

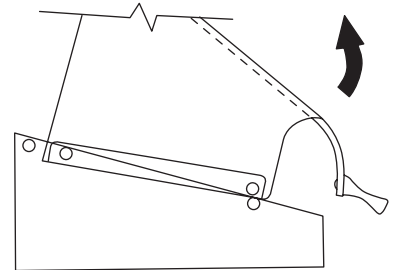

Front Pivot - Install front shoulder bolts through mounting holes in food shield. Rear of shield rests on top of shoulder bolts.

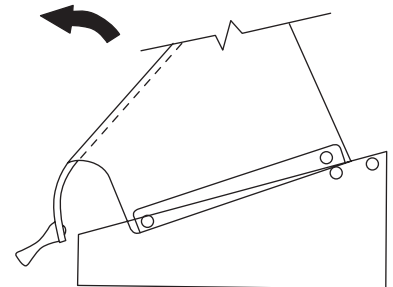

Figure 2. Optional Food Shield Components

### OPERATION

#### General

Volume, preference and experience will determine what temperature setting is best for your operation. When holding hot dogs for long periods of time, it is recommended to keep the setting under 160°F (71°C). This may vary depending on the type of hot dog used and the production rate required. If appearance of the hot dog is deteriorating rapidly, reduce temperature setting.

As the hot dogs turn in their own juices, they become self-basting, searing in all of the natural flavor. Excess juices are allowed to collect in the lower lip at the front of the grill. These juices can be absorbed with a paper towel and discarded.

**NOTE: The driver frame will accommodate almost any diameter size hot dog or sausage up to 1-1/4" (31.8 mm).**

#### Operating Instructions

1. Turn the rocker switch (power on/off) to the ON position.
2. Set the thermostat controls to the desired setting.

**NOTE: Hot Dog Corrals (except Model HDC-20) have two separate heating zones—upper and lower. Some custom models have left-to-right controls. Each zone is controlled by a separate thermostat.**

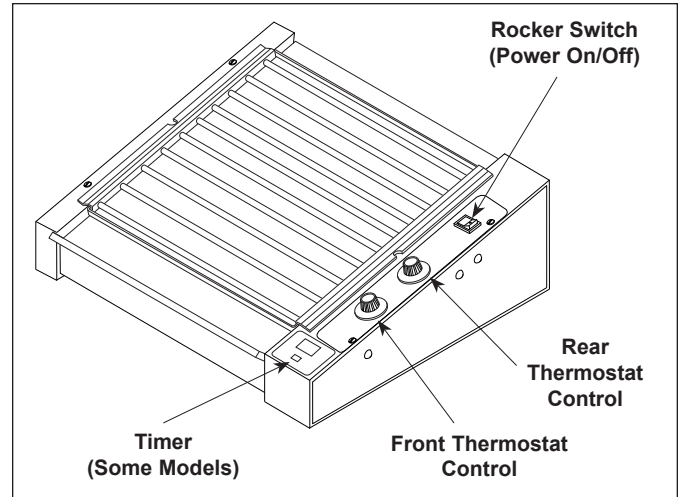

Figure 3. Controls

3. **Timer:** Set the timer by pressing the Start button once. To change the timer, press and hold the Start button.

**NOTE: The timer default setting is 8 minutes. The timer range is 1 - 15 minutes.**

4. Allow 10-15 minutes as a warm-up period, then place the hot dogs in the driver frame assembly.

## MAINTENANCE

### ⚠ CAUTION ⚠

Chlorides or phosphates in cleaning agents (e.g. bleach, sanitizers, degreasers or detergents) could cause permanent damage to stainless steel equipment. The damage is usually in the form of discoloration, dulling of metal surface finish, pits, voids, holes or cracks. This damage is permanent and not covered by warranty. The following tips are recommended for maintenance of your stainless steel equipment:

- Always use soft, damp cloth for cleaning, rinse with clear water and wipe dry. When required, always rub in direction of metal polish lines.
- Routine cleaning should be done daily using soap, ammonia detergent and water.
- Stains and spots should be sponged using a vinegar solution.
- Finger marks and smears should be rubbed off using soap and water.
- Hard water spots should be sponged using a vinegar solution.

### ⚠ WARNING ⚠

Turn the unit off, disconnect the power source and allow the unit to cool down before performing any service or maintenance on the unit.

### ⚠ WARNING ⚠

Do not use a sanitizing solution or abrasive materials. The use of these may cause damage to the stainless steel finish.

## Cleaning

The unit requires a minimum amount of maintenance. To ensure proper operation, clean the unit after every use.

1. Remove the Driver Frame (Figure 4) and soak in hot detergent water and clean using a soft brush. Rinse in clear water and dry with a clean, dry towel. **Verify that the Roller Rods rotate easily and have side to side motion by testing them with your fingers.**
2. Wash cooking surface with a sudsy cloth and rinse with a clean, wet cloth.

## Inspecting and Aligning Drive Parts

If the Drive Frame does not move smoothly, or during a Motor replacement, inspect and align the drive parts as follows:

1. Turn the Rocker Switch (power On/Off) to OFF and unplug the power cord.
2. Remove the right and left side Panel Covers.
3. Place a straightedge on the outside surface of the Pivot Arm and Motor Arm (Figure 5). There should be **no gap** between the Motor Arm and the straightedge.
4. To remove any gap, loosen the setscrews on the Pivot Arm and Motor Arm (Figure 4).
5. Tighten the Pivot Arm setscrew. Allow 3/32" (2.5 mm) of in/out motion on the crossover shaft/arm

### ⚠ CAUTION ⚠

**Failure to allow room for drive parts expansion can cause binding during operation and may cause early motor failure.**

when tightening the setscrew. This will compensate for heat expansion in the parts.

6. Place the straightedge on the outer surface of the Pivot Arm and Motor Arm. Position the Motor Arm until no gap exists as shown in Figure 5.
7. Tighten the Motor Arm setscrew.

**NOTE: Be sure setscrews are resting on the flat surface of the shafts when tightening.**

8. If the Drive Frame still does not move freely, loosen setscrew and remove the Motor Arm (Figure 4) from the Motor Shaft.

Grasp both Slide Bracket Pins (Figure 4) and move them back and forth to try and determine the source of the bind. It may be necessary to adjust the height of the Slide Bracket (Figure 4).

Inspect the Drive Rollers, bearings, and Retaining Rings for wear and replace if necessary.

**NOTE: If any of the Drive Parts are replaced, repeat steps 1 - 8.**

9. Reinstall the right and left Side Panel Covers.

## MAINTENANCE (continued)

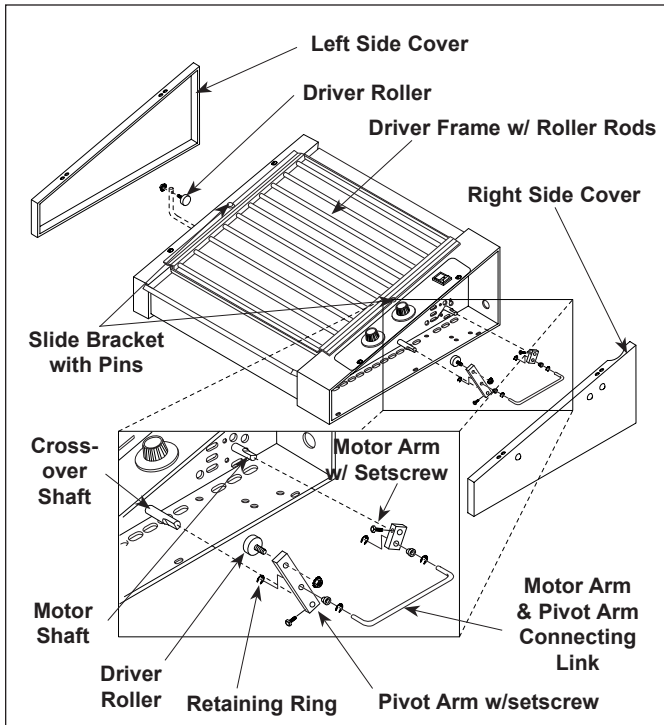

Figure 4. Drive Components

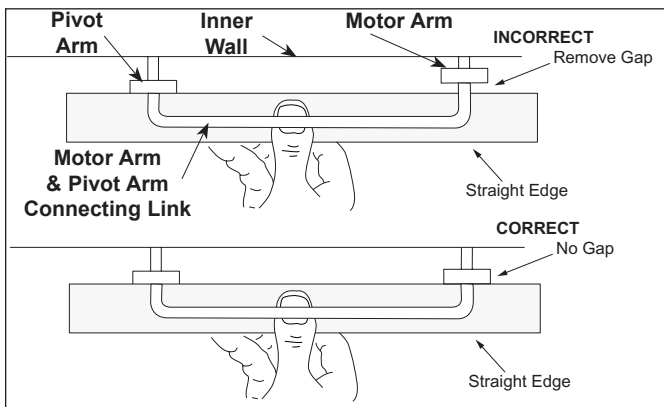

Figure 5. Aligning Drive Components

### Replacing the Black Nylon Glides

The Black Nylon Glides allow the Driver Frame to slide back and forth smoothly and also prevents it from scratching the grill surface area.

Depending on the model, the glides are attached to the Driver Frame or to the unit itself (See Figure 6 and 6A). **The glides eventually wear down with normal use and will require replacement as needed.**

**NOTE: Failure to replace missing/worn glides will result in permanent Grill Surface and Driver Frame Damage, NOT covered by warranty.**

**HDC-21A/35A ONLY:** Remove the four Retainer Rings and glides (Figure 6). Install new glides and secure with Retainer Rings.

**HDC-20/30A/50A ONLY:** Using a small screwdriver, pry the four glides up and out of the unit (Figure 6A). Push the new glides into the unit.

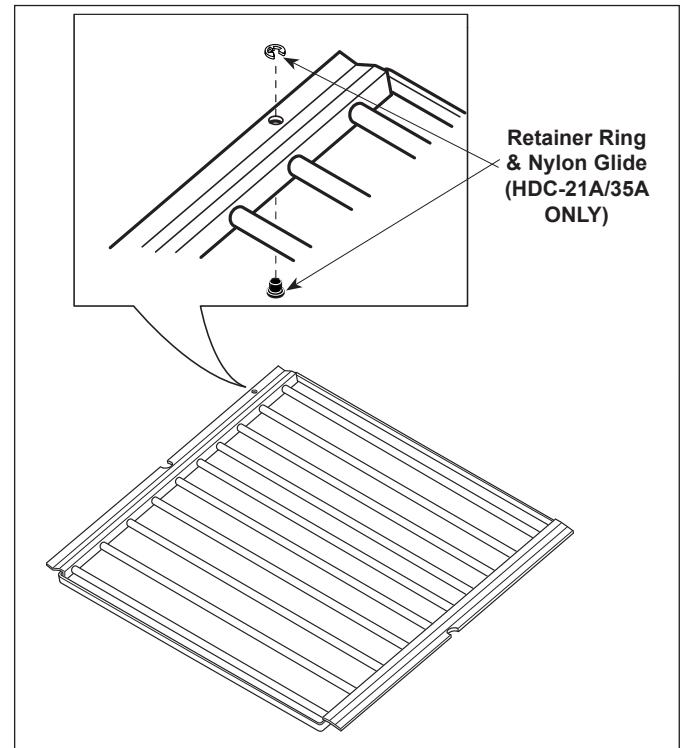

Figure 6. HDC-21A/35A ONLY

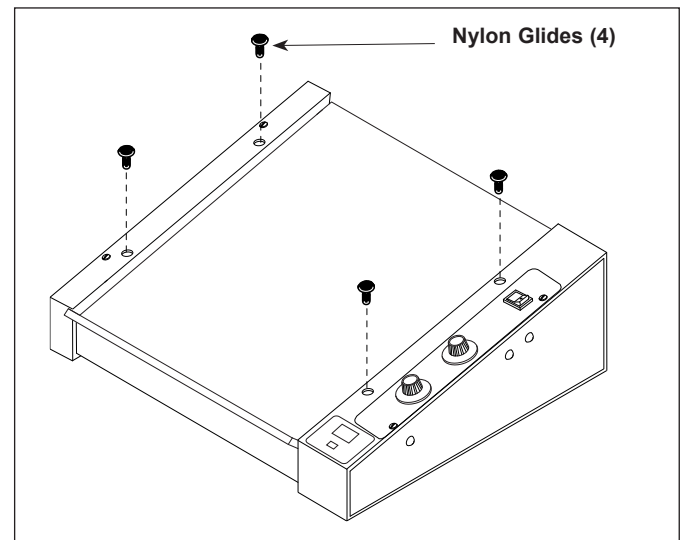

Figure 6A. HDC-20/30A/50A ONLY

## TECHNICAL THEORY OF OPERATION

### Hot Dog Corral Technical Theory of Operation

When the Rocker Switch (power On/Off) is ON, voltage flows to the capillary bulb Thermostat(s), Drive Motor Assembly, and to the Digital Timer.\*\*

**NOTE: HDC-20 units consist of a single thermostat that controls the entire grill area temperature. HDC21A/30A/35A/50A units consist of 2 Thermostats. The upper Thermostat controls the upper grill area temperature and the lower Thermostat controls the lower grill area temperature.**

Provided that the grill area temperature is below the Thermostat setting, the Thermostat calls for heat by supplying line voltage to the Heating Element.

**NOTE: The Heating Element(s) are secured to the under-side of the grill area.**

As the grill area begins to heat up, the Thermostat's bulb (mounted near the Heating Element) monitors the grill area temperature. Once the grill area temperature approaches the Thermostat setting, the Thermostat's contacts open and the Heating Element stops heating.

The heating circuit(s) will cycle on and off as needed, even at idle. The hot dogs are placed between the Roller Rods of the sliding Driver Frame Assembly. As the Drive Motor runs, it operates a linkage system which, in turn, operates the Driver Frame Assembly by moving it up and down.

As the hot dogs roll, they absorb the heat from the grill surface area.

**NOTE: The Driver Frames used in HDC-20/30A/50A units slide on four replaceable Nylon Glides that are pressed into the corners on the unit. The Driver Frames used in HDC-21A/35A units integrate four replaceable Nylon Glides with Retainers. The glides help prevent the Driver Frame from scratching the Grill area.**

**\*\* The Digital Timer is used only on some models. The customer can program the timer up to 15 minutes. It is used to monitor the product cooking/heating time. An integrated audio signal will sound for a few seconds at the end of a timed cycle.**

### TROUBLESHOOTING

**⚠ WARNING ⚠**

To avoid possible personal injury and/or damage to the unit, inspection, test and repair of electrical equipment should be performed by qualified service personnel. The unit should be unplugged when servicing.

Problem	Possible Cause	Corrective Action
Unit will not heat up. Rocket Switch (power On/Off) is ON.	Power Cord not plugged in.	Plug Power Cord into the appropriate outlet.
	Circuit Breaker is off or has been tripped in the main power supply.	Turn on or reset the Circuit Breaker.
	Thermostats not turned on.	Turn the Thermostats to the proper settings.
	Loose connections.	Check the continuity of the wiring. Tighten as needed.
	Defective Wiring.	Replace the defective wires.
	Defective Power Cord.	Check Power Cord continuity. Replace if necessary.
	Defective Rocker Switch (power On/Off).	If there is power to the switch in the ON position but no power coming out, replace the switch.
	Defective Thermostat.	Replace Thermostat.
The Drive Frame does not move smoothly.	Defective Heating Element(s).	Replace Heating Element(s).
	Drive Frame out of square.	Repair or replace Driver Frame.
	Black Driver Rollers or Nylon Glides are missing or need lubrication.	Install new Driver Rollers and/or Nylon Glides or lubricate with a small amount of food grade grease.
	Drive mechanism bent or damaged.	Replace bent or damaged components.
	Improper Drive alignment.	See "Inspecting and Aligning Drive Parts" within the Maintenance section of this manual.
The Driver Frame does not move but unit gets hot.	Defective Motor	Repair or replace Motor.
	Loose, damaged, or worn drive component(s) or loose setscrew(s).	Locate component(s) in question and refasten or replace. Tighten setscrew(s).
	Defective Motor.	Replace Motor.
The Drive Frame scratches the grill surface or side panels.	Insulation has detached and stalled the Motor Fan Blade.	Remove Base Plate and reposition the Insulation under the Insulation Retainer.
	Driver Frame is out of square, bent, or damaged.	Repair or replace Driver Frame.
The Drive Frame climbs over the product continuously or intermittently.	Nylon Glides are missing or worn.	Replace Nylon Glides according to the Maintenance section of this manual.
	One or more of the Driver Frame Roller Rods are tight and do not roll freely, or do not have side to side play.	Soak the Driver Frame in hot, soapy water for one hour. Perform the Daily Cleaning according to the Maintenance section of this manual. If the rods are still tight, use a mallet to hit the frame outwards and away from the tight rod(s) to free the rods up. If the rods are still tight, replace the Driver Frame.
Product is under or over cooked.	Improper Thermostat setting(s).	Re-adjust Thermostat(s).
	Defective Thermostat(s).	Replace Thermostat(s).

**REPLACEMENT PARTS**

**HDC-20/20RC**

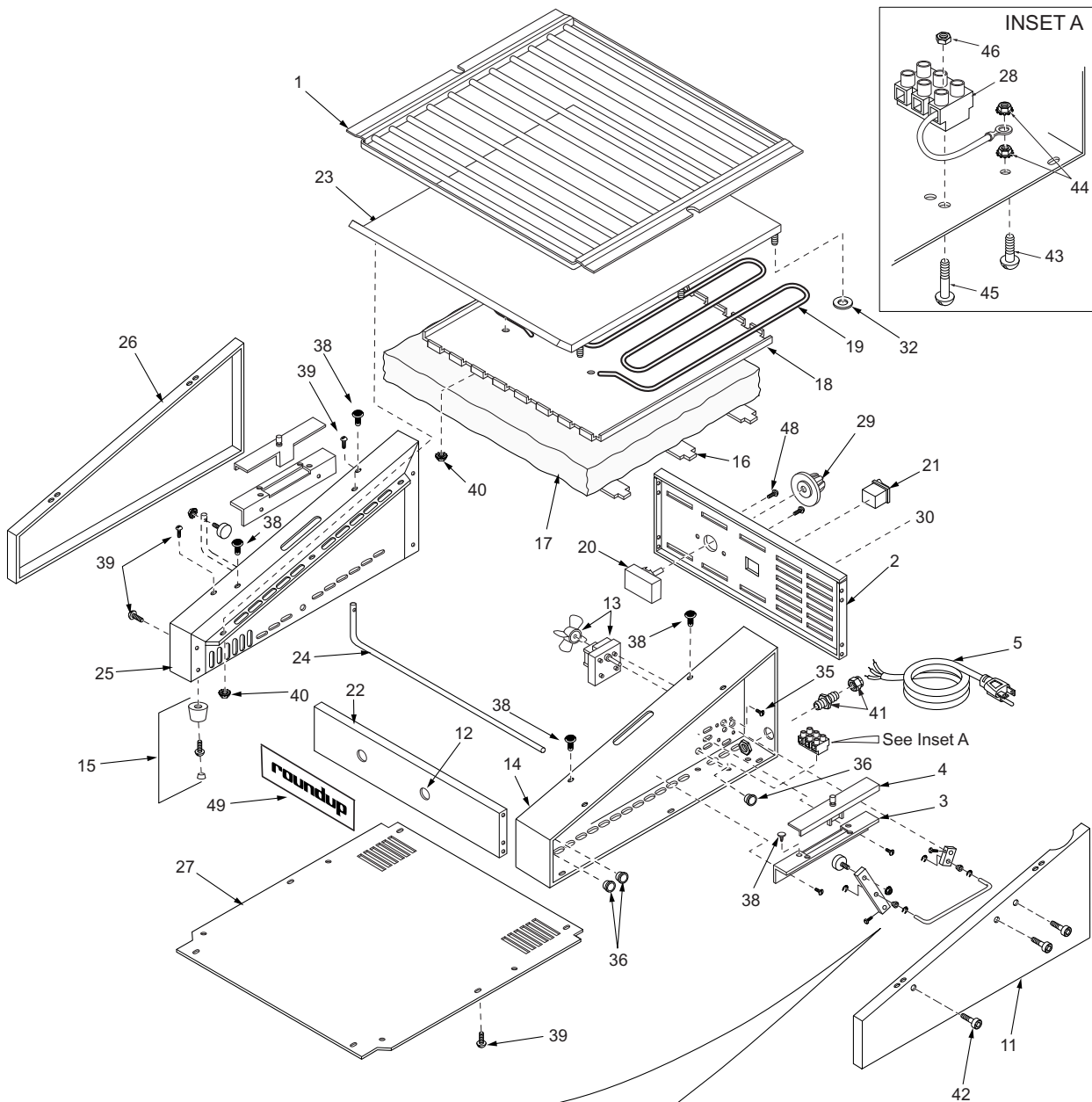

## REPLACEMENT PARTS (continued)

### HDC-20/20RC

Item	Part No.	Description	Qty.
1	0010434	Driver Assy.	1
2	0501633	Panel, Rear	1
3	0500551	Slide Bracket, Angle	2
4	0020625	Slide Channel	2
5	0700463	Power Cord, NEMA 5-15P, 120V	1
	0700453	Power Cord, CEE 7/7, 230V	1
	0700556	Power Cord (UK)	1
6	2100129	Driver Roller	2
7	030P101*	Screw, Shoulder Pivot	2
8	05K1706	Pivot Arm w/Setscrew	1
9	05K1705	Motor Arm w/Setscrew	1
10	080K217	Connecting Link Kit (Incl. # (Incl. #33 & 34)	1
11	0021213	Cover Panel, RH	1
12	300P104*	Tubular Clip, 1/8" Diameter	1
13	7000270	Drive Motor, 120V 3 RPM	1
	7000263	Drive Motor, 230V 3 RPM	1
14	0020603	Panel, RH	1
15	210K127	Foot Kit (Set of 4)	1
16	0501708	Retainer, Insulation	3
17	0400235	Insulation	1
18	0501670	Retainer, Heater	1
19	4030227	Heating Element, 120V, 1000 Watt	1
	4030232	Heating Element, 230V 1000 Watt	1
20	7000215	Thermostat Kit F°	1
	7000213	Thermostat Kit C°	1
21	4010151	Rocker Switch, Power On/Off, 120V	1
	4010137	Rocker Switch, Power On/Off, 230V	1
22	0501752	Panel, Front (HDC-20)	1
	0502125	Panel, Front (HDC-20RC)	1
23	7000382	Grill Kit	1
24	0800216	Shaft/Arm, Crossover	1

Item	Part No.	Description	Qty.
25	0020604	Panel, LH	1
26	0021214	Cover, Panel, LH	1
27	0501631	Panel, Bottom	1
28	7000136	Terminal Block Kit	1
29	2100130	Knob, Thermostat, F°	1
	2100225	Knob, Thermostat, C°	1
30	1000920	Label, Control Panel	1
32	325P104*	Washer, Flat, SS, 1/4"	1
33	215P152*	Nylon Bushing, Pivot Arm/Motor Arm	1
34	211P127*	Retaining Ring	1
35	310P109*	Screw, #10-32 x 3/8"	1
36	040P119*	Snap Bushing, 5/8"	1
37	215P151*	Nylon Bushing Crossover Shaft	1
38	218P113*	Nylon Glides (black)	1
39	308P115*	Screw, #8-32 x 3/8"	1
40	310P146*	Nut, Hex, #10-32	1
41	040K251	Strain Relief Kit	1
42	325P169*	Shoulder Bolt, Socket Hd., 5/16 x 1/2"	1
43	308P124*	Screw, One-Way, #8-32 x 1/2"	1
44	308P143*	Nut, KEPS, #8-32	1
45	306P123*	Screw, #6-32 x 7/8"	1
46	306P130*	Nut, KEPS, #6-32	1
47	325P166*	Setscrew, 1/4-28 x 3/8"	1
48	306P104*	Screw, #6-32 x 1/4"	1
49	1000136	Roundup Emblem	1
<b>NS</b>	<b>040K108</b>	Nylon Bushing & Retainer Kit (Incl. #33, 34, & 37)	1
<b>NS</b>	<b>7000193</b>	Food Shield Mounting Hdwe Kit (Optional-see page 9 for components)	1

\* Only available in quantities of 10.  
**NS** indicates that the item is not shown in the Replacement Parts graphic.



**REPLACEMENT PARTS (continued)**

**HDC-21A/30A/35A/50A**

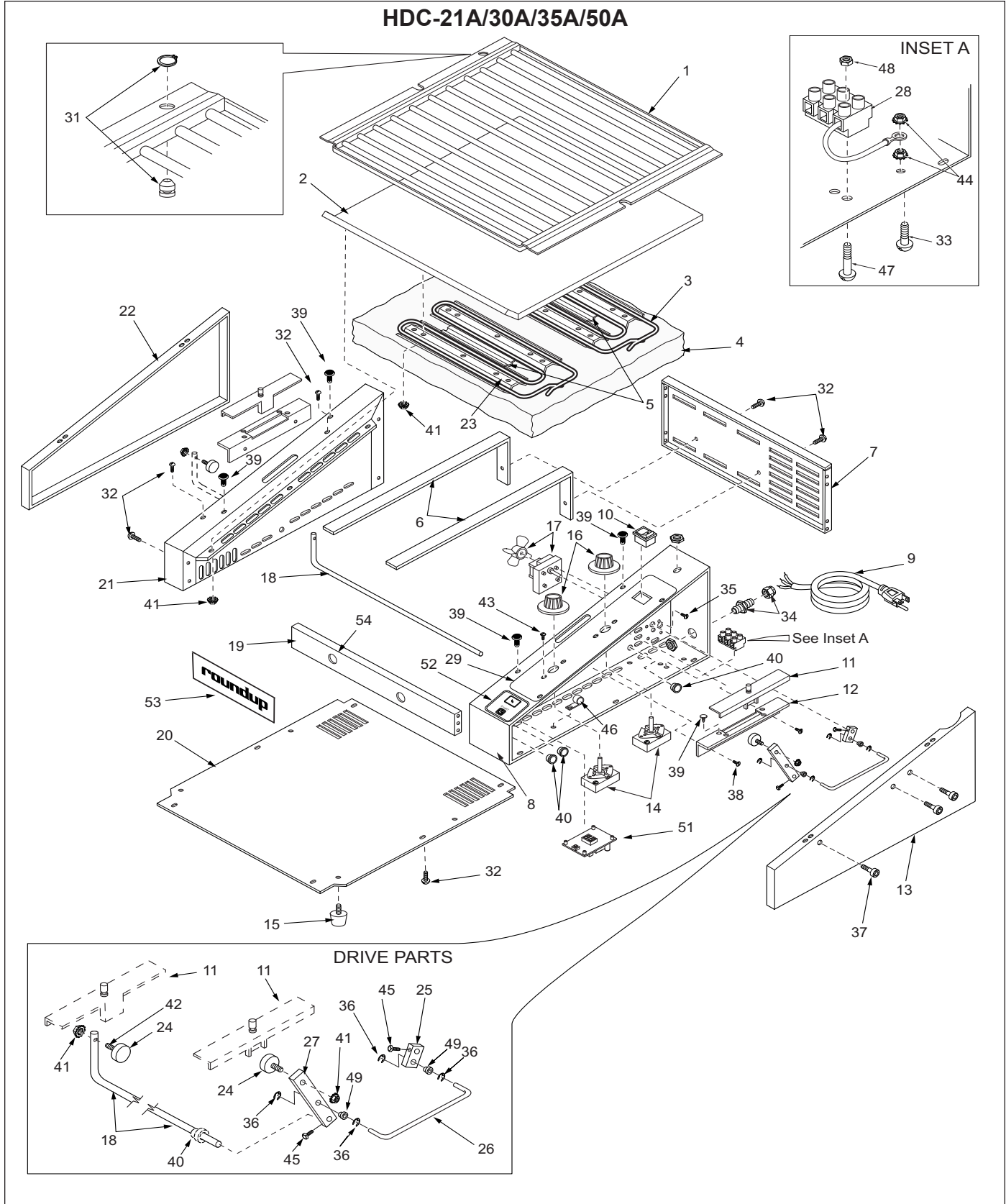

## REPLACEMENT PARTS (continued)

### HDC-21A/31A/35A/50A

Item	Part No./Qty.				Description
	HDC-21A	HDC-30A	HDC-35A	HDC-50A	
1	0010366 / 1 0011583 / 1	0020595 / 1 0020989 / 1	0010368 / 1 0011584 / 1	7000410 / 1 0021448 / 1	Driver Assy., Standard Driver Assy., 10 rods, Special Order
2	7000383 / 1	7000384 / 1	7000385 / 1	7000386 / 1	Grill Assy. Kit
3	4030146 / 2 4030152 / 2	4030199 / 2 4030202 / 2	4030147 / 2 4030151 / 2	4030147 / 2 4030151 / 2	Heating Element, 120V Heating Element, 230V
	-	-	-	4030311 / 2	Heating Element, Sonic, 120V
4	0400145 / 1	0400185 / 1	0400146 / 1	0400150 / 1	Insulation
5	0500667 / 2	0500667 / 2	0500667 / 2	0500667 / 2	Retainer, Bulb
6	0500664 / 2	0050714 / 2	0500664 / 2	0500714 / 2	Retainer, Insulation
7	0500570 / 1	0500570 / 1	0500619 / 1	0500619 / 1	Panel, Rear
8	0021008 / 1	0021007 / 1	0021008 / 1	0021007 / 1	Panel, RH
	-	-	-	0021302 / 1	Panel, RH (Timer Unit Only)
9	0700463 / 1 0700453 / 1 0700556 / 1	0700463 / 1 0700453 / 1 0700556 / 1	0700463 / 1 0700453 / 1 0700556 / 1	0700463 / 1 0700453 / 1 0700556 / 1	Power Cord, 120V, 6 ft. NEMA 5-15P Power Cord, 230V, 6ft. CEE 7/7 Power Cord, UK BS 1363
	-	-	-	0700602 / 1	Power Cord, 120V, 8 ft.
10	4010151 / 1 4010137 / 1	4010151 / 1 4010137 / 1	4010151 / 1 4010137 / 1	4010151 / 1 4010137 / 1	Rocker Switch, Power On/Off, 120V Rocker Switch, Power On/Off, 230V
11	0020625 / 2	0020625 / 2	0020625 / 2	0020625 / 2	Slide Channel
12	0500551 / 2	0500551 / 2	0500551 / 2	0500551 / 2	Slide Angle Bracket
13	0021211 / 1	0021217 / 1	0021211 / 1	0021217 / 1	Cover, Panel, RH
14	7000215 / 2 7000213 / 2	7000215 / 2 7000213 / 2	7000215 / 2 7000213 / 2	7000215 / 2 7000213 / 2	Thermostat Kit F° (Incl. #16a and 16c) Thermostat Kit C° (Incl. #16b)
15	210K127 / 1	210K127 / 1	210K127 / 1	210K127 / 1	Foot Kit (Set of 4)
16a	2100130 / 1	2100130 / 1	2100130 / 1	2100130 / 1	Knob, Thermostat, F°
16b	2100225 / 2	2100225 / 2	2100225 / 2	2100225 / 2	Knob, Thermostat, C°
16c	-	-	-	2100133 / 2	Knob, Thermostat. 1 - 10 Range
17	7000270 / 1 7000263 / 2	7000270 / 1 7000263 / 2	7000270 / 1 7000263 / 2	7000270 / 1 7000263 / 2	Drive Motor, 120V, 3 RPM Drive Motor, 230V, 3 RPM
18	0800253 / 1	0800253 / 1	0800255 / 1	0800255 / 1	Shaft/Arm, Crossover
19	0500559 / 1	0500559 / 1	0500618 / 1	0500618 / 1	Panel, Front
20	0500560 / 1	0501105 / 1	0500616 / 1	0500713 / 1	Panel, Bottom
21	0020217 / 1	0020234 / 1	0020217 / 1	0020234 / 1	Panel, LH
22	0021212 / 1	0021216 / 1	0021212 / 1	0021216 / 1	Cover, Panel, LH
23	0500556 / 4	0500556 / 4	0500556 / 8	0500556 / 8	Retainer, Heater
24	2100129 / 2	2100129 / 2	2100129 / 2	2100129 / 2	Driver Roller
25	05K1705 / 1	05K1705 / 1	05K1705 / 1	05K1705 / 1	Motor Arm w/Setscrew
26	080K254 / 1	080K217 / 1	080K254 / 1	080K217 / 1	Connecting Link Kit (Incl. #36 & 49)
27	05K1706 / 1	05K1706 / 1	05K1706 / 1	05K1706 / 1	Pivot Arm with Setscrew
28	7000136 / 1	7000136 / 1	7000136 / 1	7000136 / 1	Terminal Block Kit
29	1000921 / 1	1000921 / 1	1000921 / 1	1000921 / 1	Label, Control Panel
31	210P128* / 1	-	210P128* / 1	-	Driver Frame Glide w/ Retainer (HDC-21A/35A Only)
32	308P103* / 4	308P103* / 4	308P103* / 4	308P103* / 4	Screw, #8-32 x 1/4"
33	308P124* / 1	308P124* / 1	308P124* / 1	308P124* / 1	Screw, One-Way, #8-32 x 1/2"
34	040K251 / 1	040K251 / 1	040K251 / 1	040K251 / 1	Strain Relief

\* Only available in quantities of 10.

NS indicates that the item is not shown in the Replacement Parts graphic

**REPLACEMENT PARTS (continued)**

Item	Part No./Qty.				Description
	HDC-21A	HDC-30A	HDC-35A	HDC-50A	
35	310P103* / 1	310P103* / 1	310P103* / 1	310P103* / 1	Screw, #10-32 x 1/4"
36	211P127* / 4	211P127* / 4	211P127* / 4	211P127* / 4	Retaining Ring
37	325P169* / 1	325P169* / 1	325P169* / 1	325P169* / 1	Shoulder Bolt, Socket Hd., 5/16 x 1/2"
38	308P151* / 1	308P151* / 1	308P151* / 1	308P151* / 1	Screw, SEMS, #8-32 x 5/16"
39	218P113 / 1	218P113* / 1	218P113 / 1	218P113* / 2	Nylon Glides (Black)
40	215P151* / 1	215P151* / 1	215P151* / 1	215P151* / 1	Nylon Bushing, Crossover Shaft
41	310P146* / 1	310P146* / 1	310P146* / 1	310P146* / 1	Nut, #10-32
42	030P101* / 1	030P101* / 1	030P101* / 1	030P101* / 1	Screw, Shoulder Pivot
43	306P104* / 1	306P104* / 1	306P104* / 1	306P104* / 1	Screw, #6-32 x 1/4"
44	308P143* / 1	308P143* / 1	308P143* / 1	308P143* / 1	Nut, KEPS, #8-32
45	325P166* / 1	325P166* / 1	325P166* / 1	325P166* / 1	Setscrew, 1/4-28 x 3/8"
46	406P234* / 1	406P234* / 1	406P234* / 1	406P234* / 1	Wire Strap
47	306P123* / 1	306P123* / 1	306P123* / 1	306P123* / 1	Screw, #6-32 x 7/8"
48	306P130* / 1	306P130* / 1	306P130* / 1	306P130* / 1	Nut, KEPS, #6-32
49	215P152* / 1	215P152* / 1	215P152* / 1	215P152* / 1	Nylon Bushing, Pivot Arm/Motor Arm
50	300P104* / 1	300P104* / 1	300P104* / 1	300P104* / 1	Tubular clip, 1/8" Diameter
51	-	-	-	4070046 / 1	Timer, Electronic (Some Models)
52	-	-	-	1001079 / 1	Label, Timer (Some Models)
53	1000136 / 1	1000136 / 1	1000136 / 1	1000136 / 1	Roundup Emblem
54	-	-	-	304P105 / 4	Nut, Hex, KEPS, #4-40
<b>NS</b>	<b>040K108 / 1</b>	<b>040K108 / 1</b>	<b>040K108 / 1</b>	<b>040K108 / 1</b>	<b>Nylon Bushing &amp; Retainer Kit (Incl. # 36, 40, &amp; 49)</b>
<b>NS</b>	<b>406P107* / 1</b>	<b>406P107* / 1</b>	<b>406P107* / 1</b>	<b>406P107* / 1</b>	<b>Cable Tie</b>
<b>NS</b>	<b>406P148* / 1</b>	<b>406P148* / 1</b>	<b>406P148* / 1</b>	<b>406P148* / 1</b>	<b>Wire Nut</b>
<b>NS</b>	<b>7000193</b>	<b>7000193</b>	<b>7000193</b>	<b>7000193</b>	<b>Food Shield Mounting Hdwe. Kit (Optional-see Page 8 for components)</b>

\* Only available in quantities of 10.

**NS** indicates that the item is not shown in the Replacement Parts graphic

**WIRING DIAGRAMS**

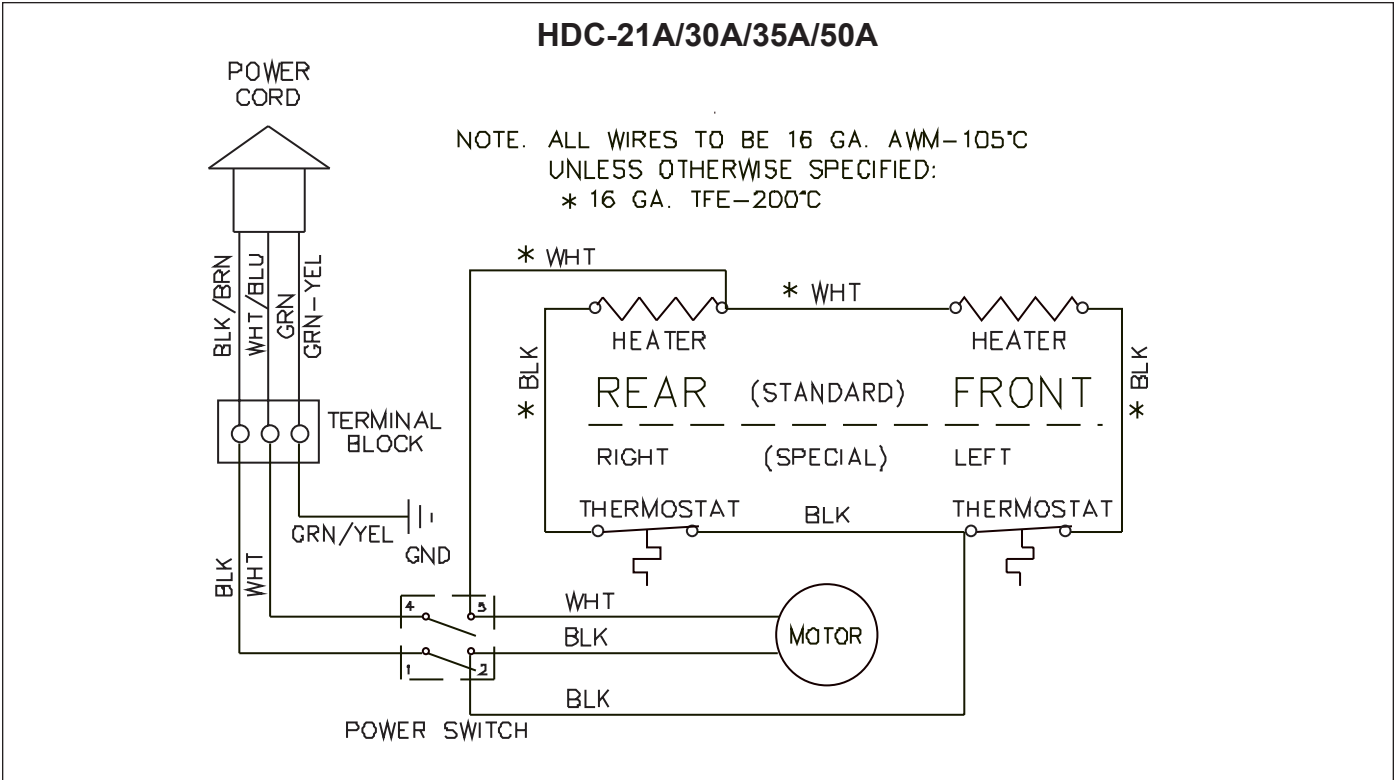
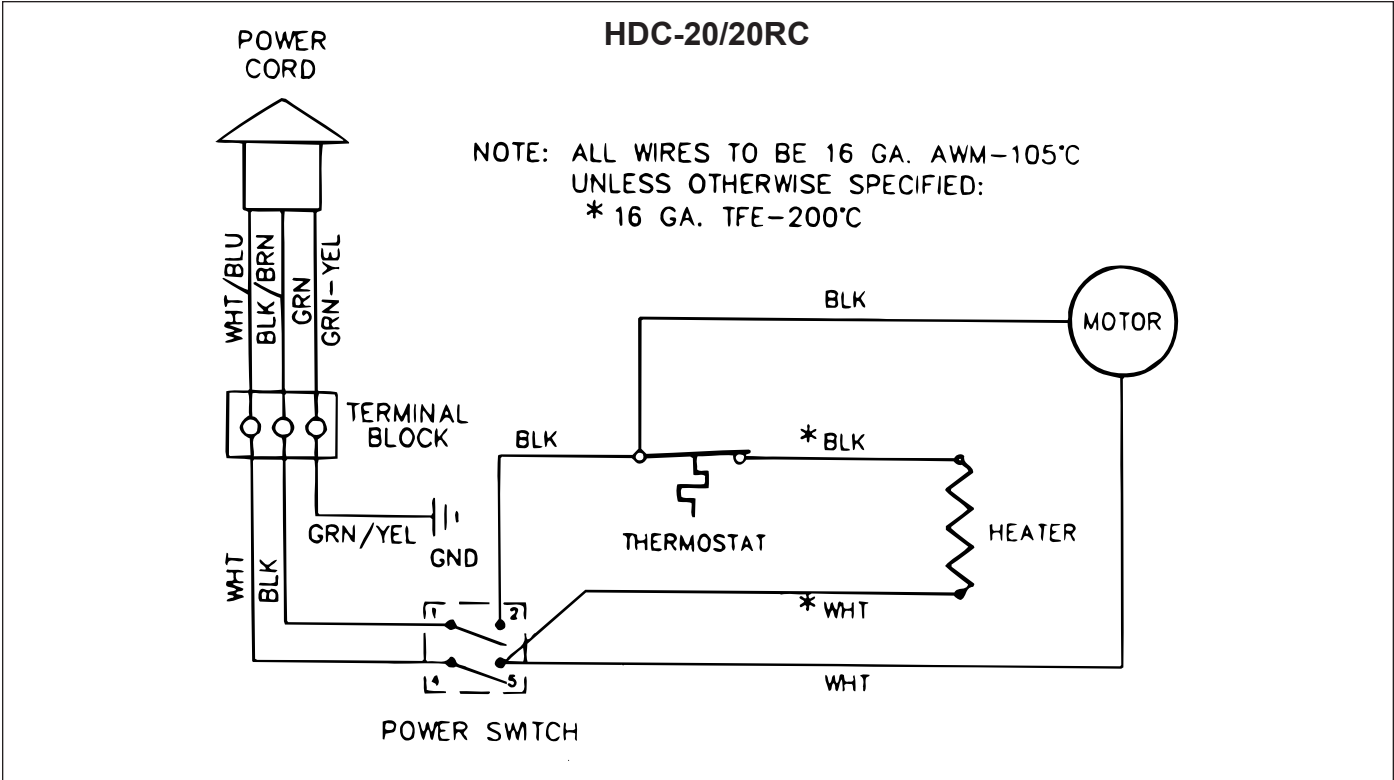

## LIMITED WARRANTY

Equipment manufactured by Roundup Food Equipment Division of A.J. Antunes & Co. has been constructed of the finest materials available and manufactured to high quality standards. These units are warranted to be free from mechanical and electrical defects for a period of one year from date of purchase or 18 months from shipment from factory, whichever occurs first, under normal use and service, and when installed in accordance with manufacturer's recommendations. To insure continued proper operation of the units, follow the maintenance procedure outlined in the Owner's Manual.

1. This warranty does not cover cost of installation, defects caused by improper storage or handling prior to placing of the Equipment. This warranty does not include overtime charges or work done by unauthorized service agencies or personnel. This warranty does not cover normal maintenance, calibration, or regular adjustments as specified in operating and maintenance instructions of this manual, and/or labor involved in moving adjacent objects to gain access to the Equipment. This warranty does not cover consumable items such as platen release sheet and conveyor belt wraps. **This warranty does not pay travel, mileage, or any other charges for an authorized service agency to reach the equipment location.**
2. Roundup reserves the right to make changes in design or add any improvements on any product. The right is always reserved to modify equipment because of factors beyond our control and government regulations. Changes to update equipment do not constitute a warranty charge.
3. If shipment is damaged in transit, the purchaser should make a claim directly upon the carrier. Careful inspection should be made of the shipment as soon as it arrives and visible damage should be noted upon the carrier's receipt. Damage should be reported to the carrier. This damage is not covered under this warranty.
4. Warranty charges do not include freight or foreign, excise, municipal or other sales or use taxes. All such freight and taxes are the responsibility of the purchaser.
5. THIS WARRANTY IS EXCLUSIVE AND IS IN LIEU OF ALL OTHER WARRANTIES, EXPRESSED OR IMPLIED, INCLUDING ANY IMPLIED WARRANTY OR MERCHANTABILITY OR FITNESS FOR A PARTICULAR PURPOSE, EACH OF WHICH IS HEREBY EXPRESSLY DISCLAIMED. THE REMEDIES DESCRIBED ABOVE ARE EXCLUSIVE AND IN NO EVENT SHALL ROUNDUP BE LIABLE FOR SPECIAL CONSEQUENTIAL OR INCIDENTAL DAMAGES FOR THE BREACH OR DELAY IN PERFORMANCE OF THIS WARRANTY.



180 Kehoe Blvd. • Carol Stream, Illinois 60188

Telephone (630) 784-1000 • FAX (630) 784-1650  
Toll Free 1-877-392-7854 (in the U.S.A. and Canada)  
[www.ajantunes.com](http://www.ajantunes.com)