

# FILM-TECH

**THE INFORMATION CONTAINED IN THIS ADOBE ACROBAT PDF FILE IS PROVIDED AT YOUR OWN RISK AND GOOD JUDGMENT.**

**THESE MANUALS ARE DESIGNED TO FACILITATE THE EXCHANGE OF INFORMATION RELATED TO CINEMA PROJECTION AND FILM HANDLING, WITH NO WARRANTIES NOR OBLIGATIONS FROM THE AUTHORS, FOR QUALIFIED FIELD SERVICE ENGINEERS.**

**IF YOU ARE NOT A QUALIFIED TECHNICIAN, PLEASE MAKE NO ADJUSTMENTS TO ANYTHING YOU MAY READ ABOUT IN THESE ADOBE MANUAL DOWNLOADS.**

**[WWW.FILM-TECH.COM](http://WWW.FILM-TECH.COM)**



AUTHORIZED DISTRIBUTOR:  
**JARCO INDUSTRIES**  
TOLL FREE ORDERING 800-458-7578  
WWW.CONCESSIONSTANDS.COM

Part No. 69922  
Revised May 2002

# DISCOVERY

## Instruction Manual

Model #2556





 **GOLD MEDAL**<sup>®</sup>  
FUNFOOD EQUIPMENT & SUPPLIES

Cincinnati, OH 45241-4807 USA  
[www.gmpopcorn.com](http://www.gmpopcorn.com)

# Safety Precautions

	<b>⚠ CAUTION</b>
	<p>This equipment is designed and sold for commercial use only. This equipment is not to be used by the consumer in home use. Do not allow direct contact of this equipment by the public when used in food service locations. Only personnel trained and experienced in the equipment operation may operate this equipment.</p> <p>Carefully read all installation instructions before operating the equipment.</p>

	<b>⚠ WARNING</b>
	<p>Always wear safety glasses when servicing this equipment.</p>

	<b>⚠ WARNING</b>
	<p>To avoid serious burns, do NOT touch the kettle while it is hot.</p>

	<b>⚠ WARNING</b>
	<p>Any alterations to this equipment will void the warranty and may cause a dangerous situation. NEVER make alterations to the equipment.</p> <p>Make sure all machine switches are in the OFF position before plugging the equipment into a receptacle.</p>

	<b>⚠ DANGER</b>
	<p>Machine must be properly grounded to prevent electrical shock to personnel.</p> <p>Do NOT immerse the kettle, warmer, or any other part of this equipment in water.</p> <p>Always unplug the equipment before cleaning or servicing.</p>

## NOTE

The information, specifications and illustrations contained in this manual represent the latest data available at time of publication. Right is reserved to make changes as required at the discretion of Gold Medal Products Company without notice.

# INSTALLATION INSTRUCTIONS

## Inspection of Shipment:

Unpack the shipping container and thoroughly inspect the machine for any damage that may have occurred during transit. Notify the freight carrier immediately in order to file a damage claim.

## Setup:

Your new Discovery Popcorn Machine is completely assembled and tested at the factory. Remove all packing material and tape before starting operation.

## Electrical Requirements:

Domestic models only: 120v/208v or 120v/240v 60 Hz.

A 30 amp – 4 wire wall receptacle is shipped with each machine. This receptacle will accept the attachment plug on the popper and must be used. Your electrician must furnish sufficient current for proper operation of your machine. We recommend this popper be on a dedicated and circuit protected line. (note: The Discovery “uses” both “hot to neutral” legs, 120v. The machine does not “use” the 208v or 240v, “hot to hot” connection.

	<b>⚠ DANGER</b>
	<p>Machine must be properly grounded to prevent shock in case of electrical problems.          Wall receptacle must be wired as shown on the receptacle.          Failure to wire properly will void the warranty and can result in damage to motors, elements, relay, lights, etc.</p>

## FINAL PREPARATIONS

<b>⚠ WARNING</b>

<p>To avoid serious burns, do <b>NOT</b> touch the kettle while it is hot!</p>

The popcorn machine was adjusted, inspected, and tested before it left the factory. After the machine has been installed, mount the kettle assembly in the hanger arms and plug in the kettle lead-in cord. Tighten the ring on the kettle lead-in plug.

If supplied with automatic oil delivery system:

Connect the clear oil line from the pump to the aluminum line from the popper with the supplied hose clamp. Connect the 6 pin connector from the popper to the receptacle on the oil pump. Both Bucket pump (2114 or 2114EX) and Bag-in-a-Box pump 2257H or 2257HX) have the same receptacle.

Follow the instructions provided in the oil pump manual to set the oil delivery amount. The proper amount of oil for the 32oz. Discovery is between 8oz. to 9.6oz.

To check for proper amount of oil, and assure oil is liquid, dispense a “shot” into a measuring cup.

# OPERATING INSTRUCTIONS

## CONTROLS AND THEIR FUNCTIONS

### LIGHT SWITCH

Operates on all the lights, interior and dome, on your popcorn machine.

### WARMER SWITCH

Operates the warmer in the corn storage area, keeps popped corn warm.

### KETTLE HEAT SWITCH

Operates the heating elements in the popping kettle.

### KETTLE MOTOR AND EXHAUST SWITCH

Operates both the kettle agitator motor and the exhaust blower. The exhaust blower is only required when popping corn.

### OIL SYSTEM MASTER SWITCH (If supplied)

Sends power to the oil pump, either the Bucket Pump or Bag-in-a-Box models. The warmer/blower on the oil pump is activated. The warmer/blower on the oil pump will keep coconut popping oil liquid if the doors on the base are kept closed. It may be desirable to keep this switch on at night, if you have problems keeping the coconut oil liquid. Coconut oil will congeal at temperatures below approximately 76° F [24° C].

### “RED” OIL DISPENSE MOMENTARY SWITCH(If supplied)

When pushed, will dispense the predetermined amount of oil into the kettle.

### SALT/SWEET SWITCH (If supplied)

Adjust the kettle temperature for salt or sugar based popcorn.

### LIGHT & AUDIBLE SIGNAL (LOAD – DUMP)

Alerts the operator to:



1. Load the corn and oil *or*
2. Dump the popped corn from the kettle *or*
3. Turn off the kettle heat switch if they are done popping corn

## POPPING CORN

1. Turn on all Switches.
2. When popping with coconut oil, be sure the oil is liquid. Dispense oil into a measuring cup first then use that oil for the first popping cycle.
3. When the kettle is ready (about 5-8 minutes), the Light and Audible Signal turn on. Lift the kettle lid and pour in 32 oz. of corn (use the supplied corn cup) and 8 teaspoons (21 cc) of Flavacol. Close lid.
4. Press the RED oil pump button (if supplied). The proper amount of oil is pumped into the kettle. The Light and Signal will turn off.
5. When the popcorn has completed popping, the Light and Signal will turn on. Dump the Popcorn.
6. On the final kettle of corn, turn the "KETTLE HEAT" switch off, just as the lids are forced open by the popping corn. This saves electricity, and helps eliminate smoke and odor after you have stopped popping.

### **REMEMBER:**

If the kettle heat switch is turned on and the Signal is sounding *one of the* following actions should be taken:

1. Load the corn and oil *or*
2. Dump the popped corn from the kettle *or*
3. Turn off the kettle heat switch if you are done popping corn

When you are finished popping, make sure "KETTLE HEAT" and "KETTLE MOTOR" switches are turned "OFF".

**NEVER LEAVE THE HEAT ON WHEN YOU ARE NOT POPPING.**

# CLEANING INSTRUCTIONS

## DAILY:

### Clean the Kettle

1. As you pop corn, wipe the kettle with a clean cloth. It is easy to keep the outside clean when the kettle is warm and the oil is not baked on.

**CAUTION:** The hot kettle will cause burns if you touch it with your hand.

2. Every night, mix a gallon of Heat'n Kleen solution (2 tablespoons per gallon of water). Turn on the kettle heat. When the water starts to boil, turn off the heat and let it work overnight.
3. The next morning, dump the solution in a bucket and wipe the inside of the kettle with a cloth.
4. A CLEAN-IN-PLACE hook is located behind the operator side kettle support arm. Just tilt the kettle to the dump position, and swing the hook into position to hold the kettle in the dumped position. This feature will help you clean the kettle.

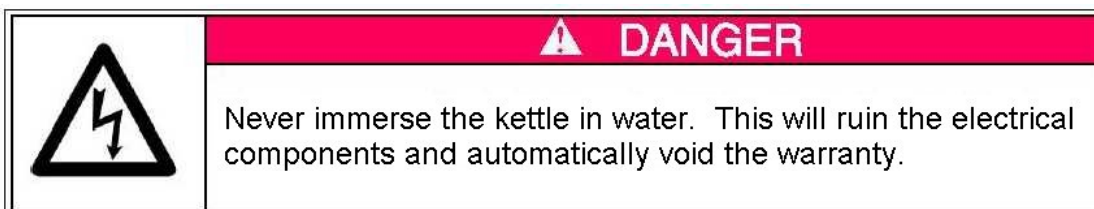

### Clean the Popcorn Machine

1. Wipe the stainless steel parts with a clean cloth and cleaner designed for stainless steel. **Do not use oven cleaners, as they will damage parts of the machine.**
2. Ammonia cleaners will damage the plastic doors. Use only non-ammonia cleaners.

## WEEKLY:

### Clean the filters in the popcorn machine

1. Loosen the screw on the filter cover plate on the ceiling inside the popper. Remove the cover and mesh filters. Clean the mesh filters in warm soapy water. Let dry overnight and reinstall.

**CAUTION:** Keeping the filters clean is important to let the exhaust system “do its job”.

2. Check the condition of the clear oil lines and tighten or replace as required.

Item No.	Part No.	Description
1	41250	Metal mesh filter



## MAINTENANCE INSTRUCTIONS

	<b>⚠ CAUTION</b>
	THE FOLLOWING SECTIONS OF THIS MANUAL ARE INTENDED ONLY FOR QUALIFIED SERVICE PERSONNEL WHO ARE FAMILIAR WITH ELECTRICAL EQUIPMENT. THESE ARE NOT INTENDED FOR THE OPERATOR.

	<b>⚠ WARNING</b>
	Adequate eye protection must be used when servicing this equipment to prevent the possibility of injury.

	<b>⚠ DANGER</b>
	Do NOT immerse the kettle, warmer, or any other part of this equipment in water. Unplug your machine before servicing.



# TROUBLESHOOTING

## LONG POPPING CYCLES

If your pop cycle is longer than 4 minutes, it can be the result of several things:

- A. HEATING ELEMENT - One of the heating elements in the kettle may be burned out. This would result in the kettle never reaching the proper operating temperature.
- B. LOW VOLTAGE - If the machine is operated on low voltage, this could cause the kettle not to reach the proper operating temperature. Voltage for each leg, with kettle turned on, must be at least 110v.
- C. INADEQUATE SUPPLY LINES - Inadequately sized electrical supply lines, in addition to being a fire hazard, would also prevent the kettle from reaching the proper operating temperature. Check with a qualified electrician.
- D. INFERIOR CORN - Inferior quality corn would result in longer popping cycles. Use only top quality hybrid popcorn from reputable suppliers. Even then, if you let your corn pick up moisture or dry out, your popping cycles will be slow.

## KETTLE DOES NOT HEAT

Before you go any further, make sure the kettle lead-in cord is plugged in and the circuit breakers are not tripped. Make sure all electrical connections are tight.

- A. KETTLE HEAT SWITCH - Check the voltage to and from the “KETTLE HEAT” switch, and if the switch is defective replace it.
- B. CONTROL - A defective thermocouple lead will cause the kettle not to heat. Check for good connections from the kettle to the control.
- C. MAIN RELAY

## MOTOR WILL NOT TURN AGITATOR

**WARNING!** If the kettle agitator shaft is not rotating, Do Not Pop corn.

Adjust the clearance between the kettle bottom and the stir blade to 1/32” (use a dime). Loosen the set screw in the collars above and below the crossbar and adjust the agitator shaft as necessary. Then re-tighten the set screws in the collars.

## OIL PUMP DOES NOT DELIVER OIL TO KETTLE

If the pump is operating but oil is not dispensed, the oil may be solid in the oil lines. If the pump is not operating see the pump manual for instructions.

## TROUBLESHOOTING

### REPLACING BROKEN GLASS

Should you accidentally break a panel of glass, it can be replaced very easily without disassembling the popper.

1. Remove all loose pieces of glass.
2. Unscrew the glass retaining strips.
3. Remove all rigid glass channels from around the glass to be replaced. Set it aside as it must be reused.
4. Carefully remove the rest of broken glass.
5. Apply decals to the new glass panel.
6. Slide rigid glass channels over the exposed sides and bottom. Maneuver the new glass into position.
7. Replace glass retaining strips using the same screws you removed earlier.

Glass Size: (Front) 31 1/16" X 32 3/16 " X 1/8 "  
(Sides) 23 15/16" x 33 3/16" x 1/8"

### **NOTE**

We do not ship glass. Obtain from local glass shop or hardware store. Always purchase double strength type glass.

# ELECTRONIC TEMPERATURE CONTROL

This section describes the Electronic Temperature Control on your 32oz. Discovery. The temperature of the popcorn kettle is controlled by an Electronic Control. Mechanical high limit thermostats are still used as a limit control. This model is also equipped with a pulsing buzzer and light that signal when the kettle heat switch is on but the kettle is at or over the temperature set point.

## Operation

The control is factory set to 412F – 415F which stops power to the kettle when the thermocouple reaches 412F – 415F. On the Discovery machine, this is also the ideal point to dump the popped corn out of the kettle. On the first start-up this is also the ideal time to load the corn and oil. Therefore if the kettle heat switch is turned on and the buzzer is sounding *one of the* following actions should be taken:

- Load the corn and oil *or*
- Dump the popped corn from the kettle *or*
- Turn off the kettle heat switch if you are done popping corn

## Adjustment of Electronic Control

If you would like to have the buzzer sound sooner or later than the factory setting, adjust the temperature setting as follows:

1. To sound the buzzer sooner, lower the temperature setting. A change of 3 to 6 seconds can be achieved with a change in temperature of 5 to 10 degrees.
2. To sound the buzzer later, raise the temperature setting.

The Electronic Control is located under the dome facing the operator on the left side. A calibrated dial is located on the control for this purpose.

## Adjustment of Buzzer Sound Level

If you would like to adjust the buzzer volume, turn the baffle on the buzzer.

1. If the kettle does not heat and the buzzer sounds continuously, then one of the following has happened:
  - a. The kettle plug is not tightened completely to the receptacle
  - b. The thermocouple wire is loose or broken.
2. If the kettle heats but the popping cycle is very long, check for a defective high limit thermostat. (buzzer operates normally)
3. If the kettle is popping normally but the buzzer does not sound, check for a defective buzzer.
4. **Caution:** If the kettle pops too quickly, and the buzzer does not sound, **do not continue popping corn.** Check for a loose thermocouple in the kettle. It is also possible the thermocouple leads are “switched” from the correct polarity. (See note 2 below)  
 Either situation will result in the control to “ask” for more heat and the kettle will operate on the high limit thermostats.

## Notes:

1. Do **not** adjust the (3) potentiometers on the electronic control. If adjusted, the performance will be erratic and could result in an over temperature condition. The only adjustment is described on page 1.
2. Thermocouple wire consists of (2) different wires made of different materials that are color-coded have a polarity. It is important that red (-) is connected to red (-), and yellow (+) is connected to yellow (+), at the lead-in plug, the receptacle, and at the electronic control. Note that the red lead is magnetic if you have trouble determining which is which. If switched, the control will not operate.

---

## ORDER SPARE PARTS

1. Identify the worn or broken part by checking it with the illustrations and parts list.
2. When ordering parts, include part number, part name, and quantity required.
3. Include you model name and machine serial number (found on nameplate) with your order.
4. Address orders to:

Jarco Industries

order toll free 800-458-7578

or order online at [www.concessionstands.com](http://www.concessionstands.com)

# HOW CHUTE DOOR WORKS

When filling bags of popcorn, take the chute door and turn it around so the front of the door is facing the popcorn machine. Place the chute door back into the door guides.

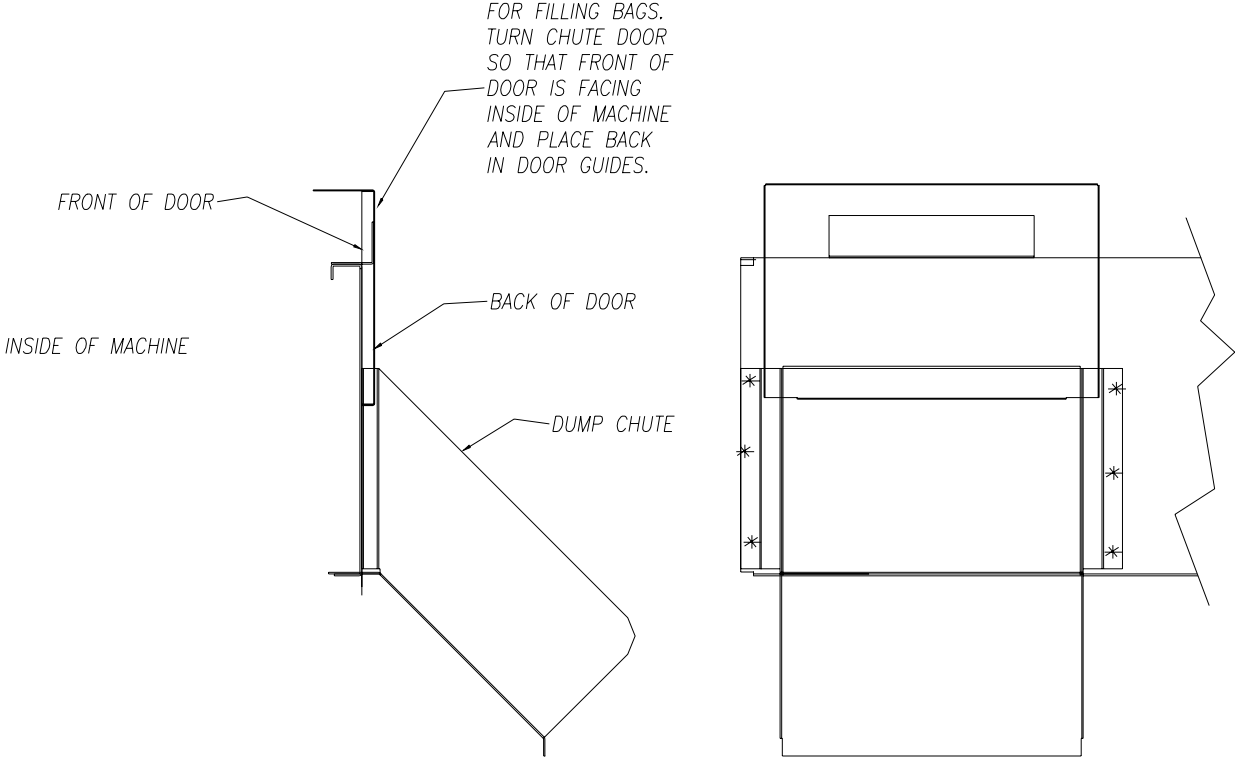

## CABINET PART LIST

Item No.	Part No.	Description
1	41351	Female Long Right
2	41352	Female Long Left
3	41349	Male Short Left
4	41350	Male Short Right
5	41190	Side Glass
6	68896	Door
7	82986	Bag Filler Chute
8	69914	Chute Door
9	40276	Old Maid Pan
10	32112	Lead In Cord
11	47026	Strain Relief
12	69801	Drop Panel With Chute (68895 Plastic Drop Panel)
13	41635	Front Glass
14	41013	Door Knob
15	50013	Magnet
16	41941	Hanger Arm Assembly
17	41833	Shock Absorber Pin
18	41618	Clean In Place Latch (Knob is 12319)
19	41380	Spur Gear
20	41432	Gear Block

# CABINET ASSEMBLY

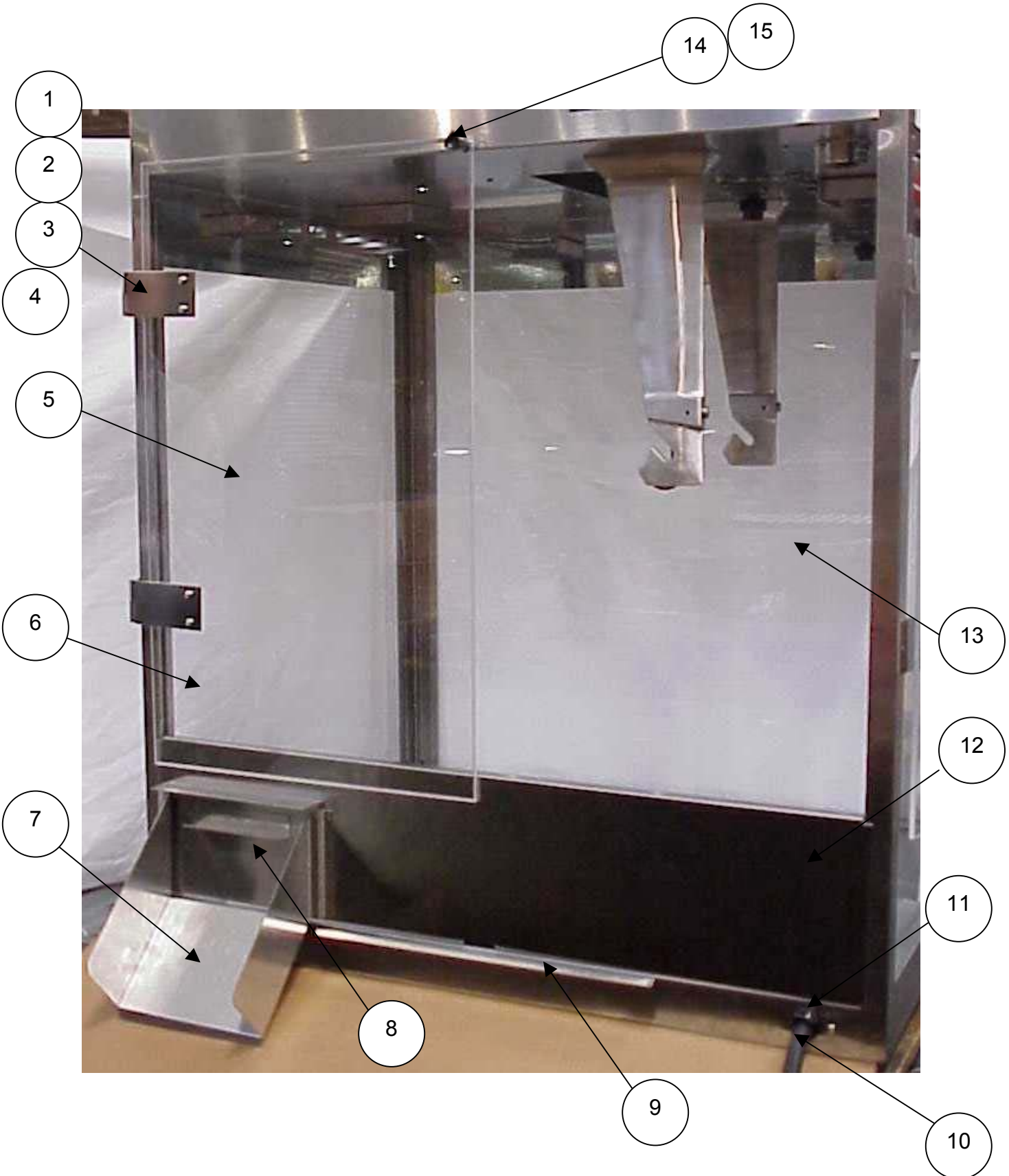



# CABINET ASSEMBLY

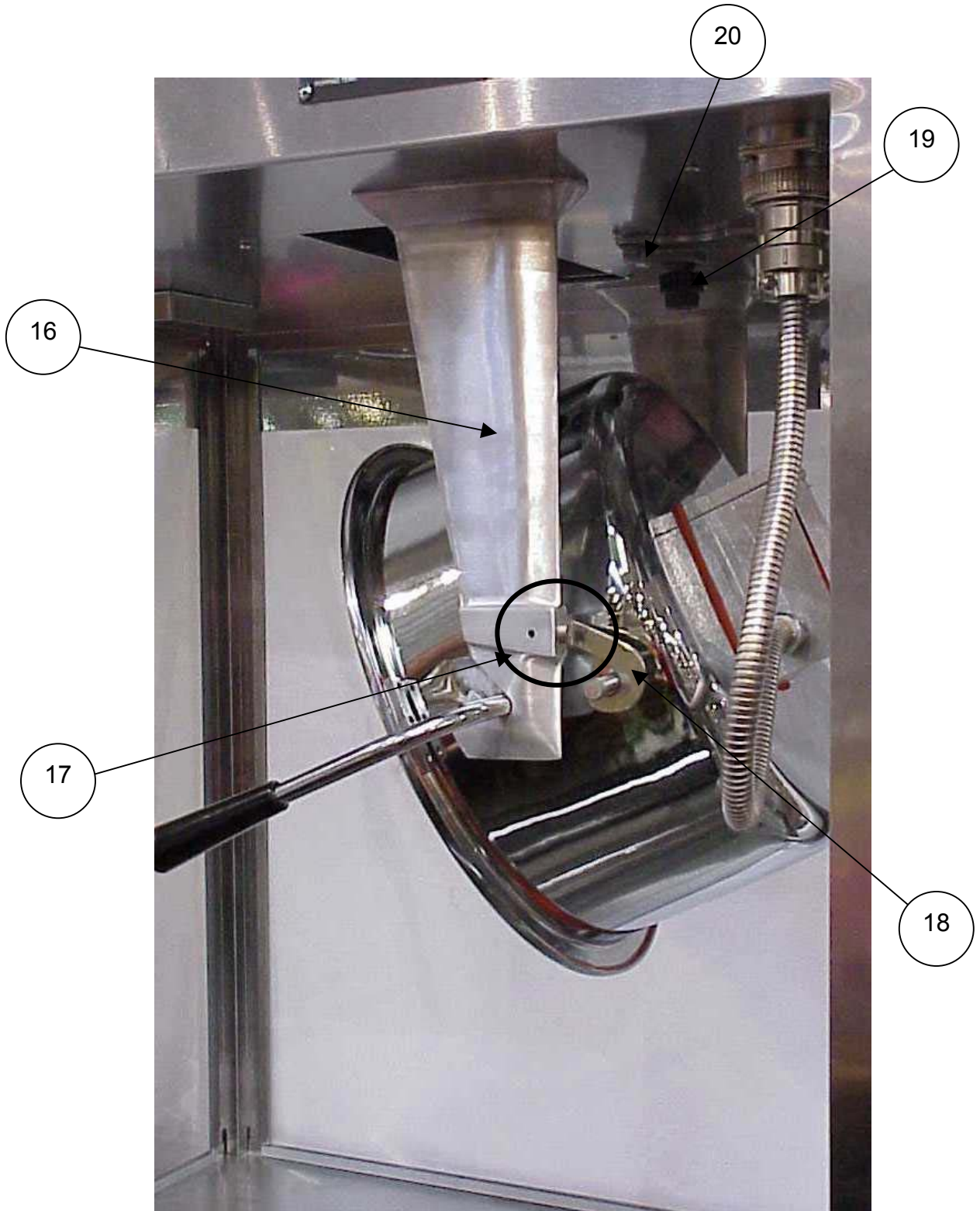

## ELECTRICAL PARTS LIST

Item No.	Part No.	Description
1	41015	Exhaust Blower, 115 V
2	46081	Relay
3	48018	Exhaust Blower, 120 V
4	48664	Electronic Temperature Control
5	47047	Lamp Holder
6	48547	Lens (for Indicator Light)
7	48545	Bulb (for Indicator Light)
8	48547	Housing (for Indicator Light)
9	61154	Buzzer
10	42798	Switches
11	48301	Motor Capacitor
12	41449	Drive Motor
13	47364	Circuit Breaker
14	41516E	Kettle Receptacle

# ELECTRICAL ASSEMBLY

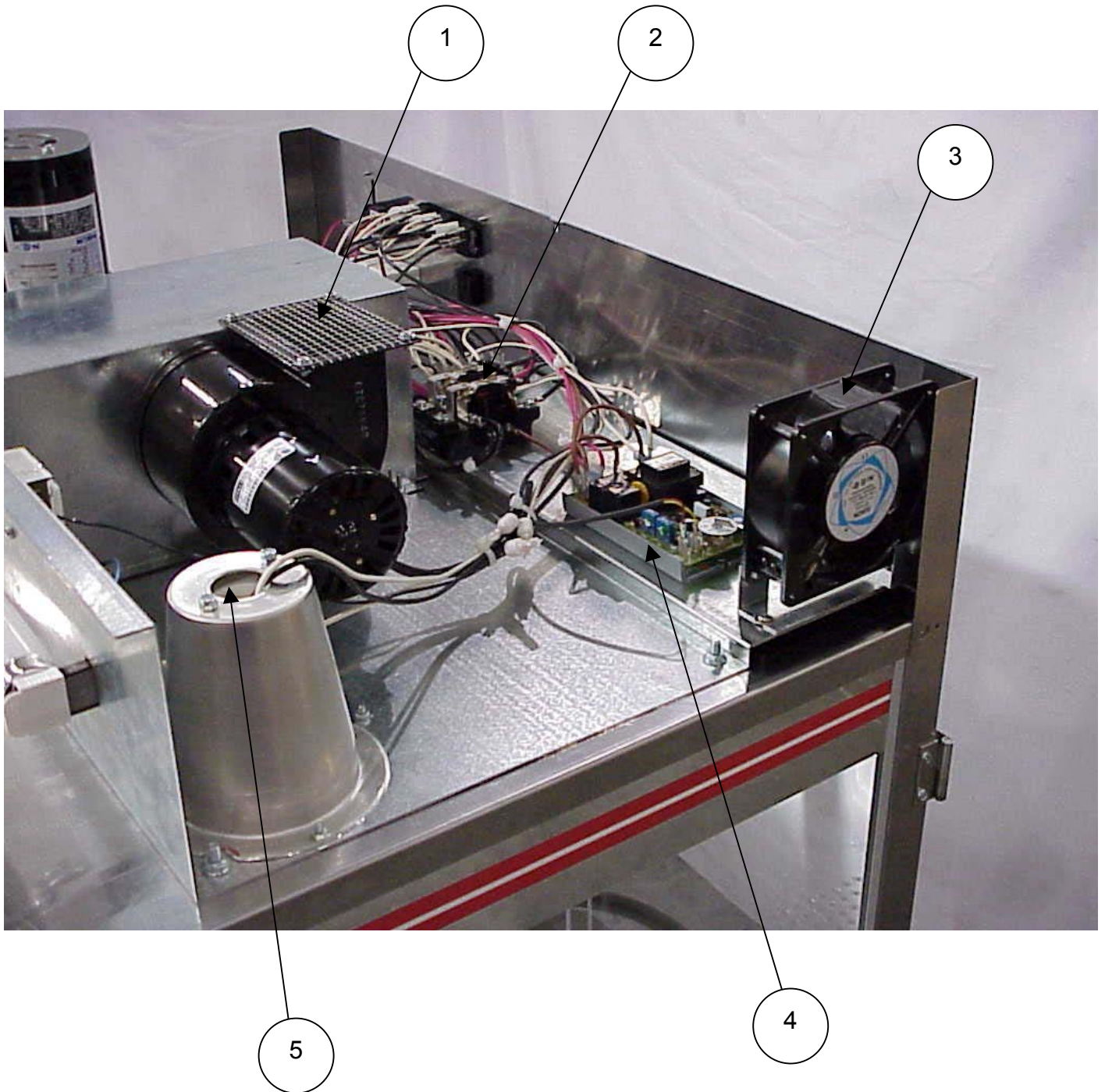



# ELECTRICAL ASSEMBLY

Control Panel Without Automatic Oil Delivery, With Optional Salt/Sweet Control.

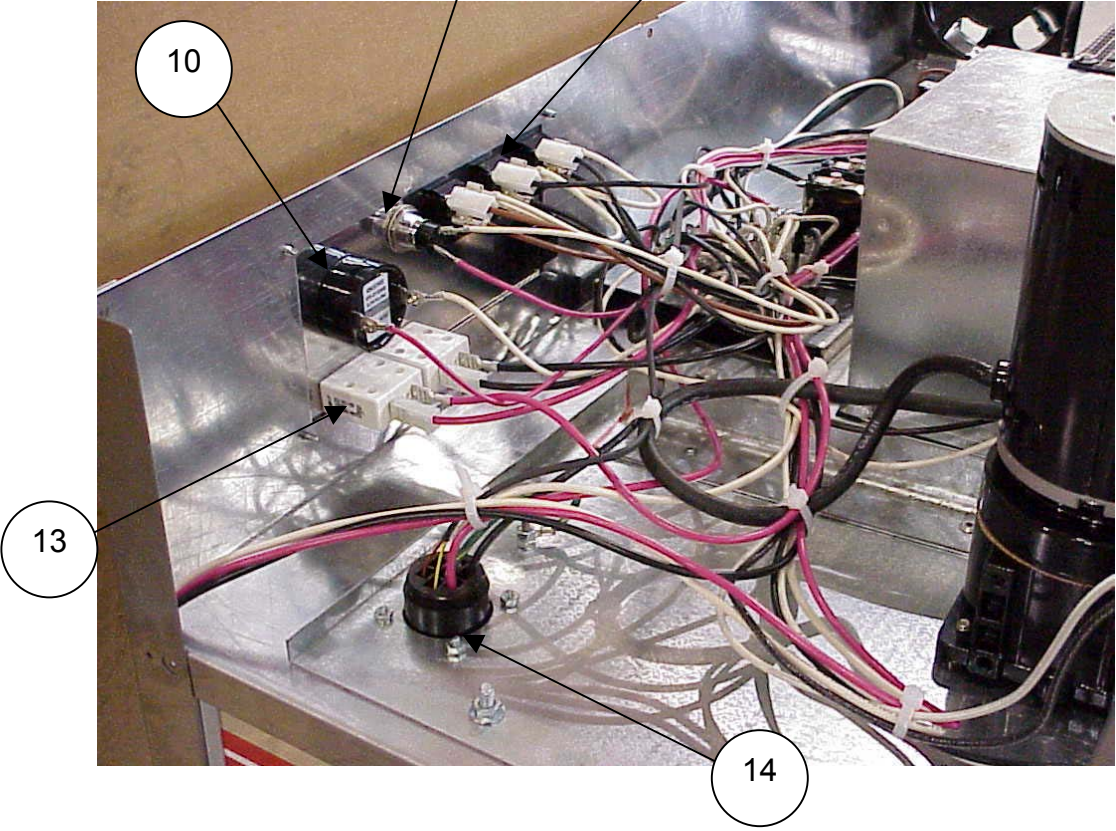
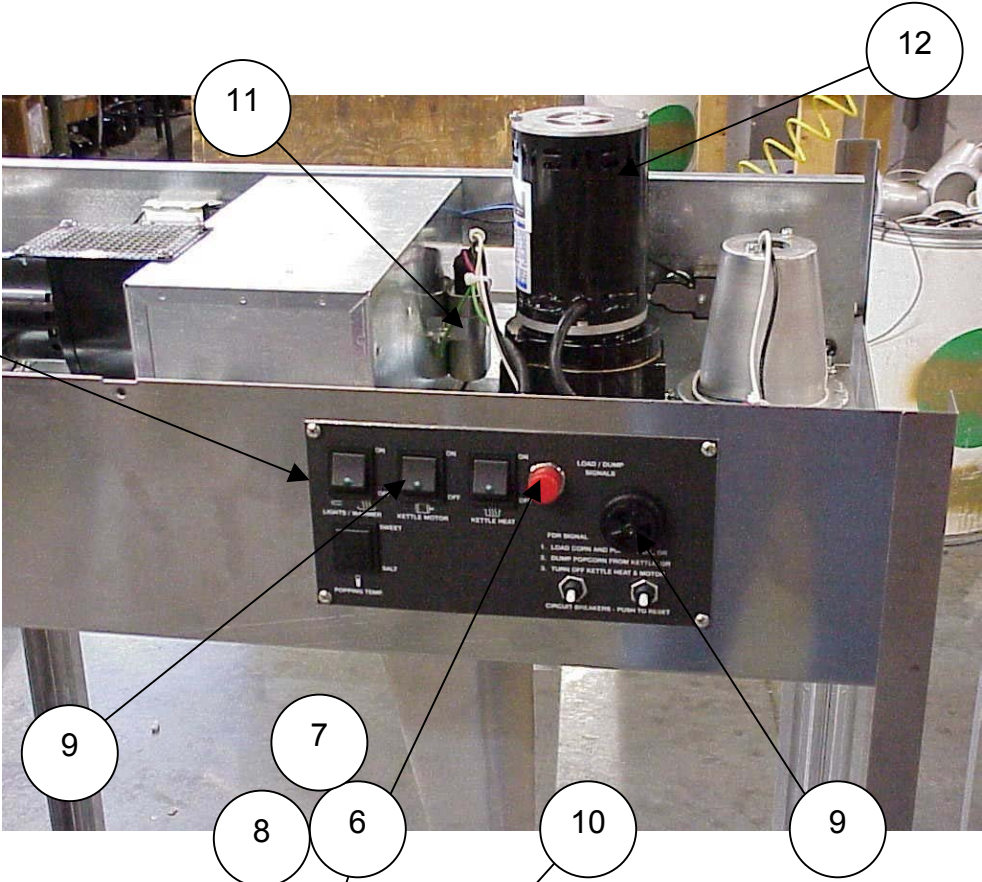

## KETTLE PARTS LIST

Item No.	Part No.	Description
1	41775	Lid and Agitator Assembly
2	41867	Oil Tube With Funnel *
3	41742	Set Screw
4	47976	Crossbar Fastener
5	41776	Crossbar Assembly
6	47749	Warning Label, Moisture
7	41944	Front, Lid Assembly
8	48977	Bushing
9	12611	LH 5/16-18 Button Soc Head
10	41400	Needle Bearing
11	41730	Woodruff Key #3
12	41380	Spur Gear
13	47326	Set Collar (2 req)
14	47977	Crossbar Fastener
15	47154	Warning Label, Immerse
16	41936	Rear, Kettle Lid
17	41940	Agitator Weld Assembly
18	47751	Set Screw
19	41450	1/4-20 x 1/2" Countersink Screw
20	61108	Thermostat Plate (Not Shown)
21	41533	Kettle Welded Assembly
22	82231	Heat Element, 1800 W
23	41534	Heat Transfer Plate
24	41536	Heat Element, 1000 W
25	47090	Heat Element, 1050 W
26	41491	Element Clamp
27	82219	Thermostat (2)
28	46311	Hex Grip Nut
29	41434	Retaining Nut
30	47999	Threaded Block (2)
31	41139	Plastic Handle
32	41597	Kettle to Shell Gasket (Not Shown)
33	41528	Kettle Shell Assembly
34	40963	Junction Box Gasket
35	48290	Kettle Lead Assembly
36	41129	Terminal Block
37	40965	Junction Box Gasket
38	41296	Junction Box Cover
39	61084	Junction Box Assembly

\* When Supplied with Oil Delivery System.

## KETTLE PARTS LIST

Item No.	Part No.	Description
41	2027E	Kettle Complete
42	47953	Kettle Plug Assembly
43	82252-24	9/16 Flexible Conduit
44	41252	1/2" Connector Fitting
45	48576	Thermocouple Wire Assembly
46	41253	Conduit Bushing (2)
47	82262	Brass Shim
48	61074	Red Wire Assembly (.458 ft)
49	61078	Black Wire Assembly (.458 ft)
50	61075	Red Wire Assembly (.385 ft)
51	61076	Green Wire Assembly (.646 ft)
52	61077	Black Wire Assembly (.250 ft)
53	61072	White Wire Assembly (.229ft)
54	61073	White Wire Assembly (.677ft)
55	62222	Red Wire Assembly (.229 ft)
56	41748	Red Wire Assembly (.646 ft)
57	48575	Wire Assembly (Does not include thermocouple)

# KETTLE ASSEMBLY

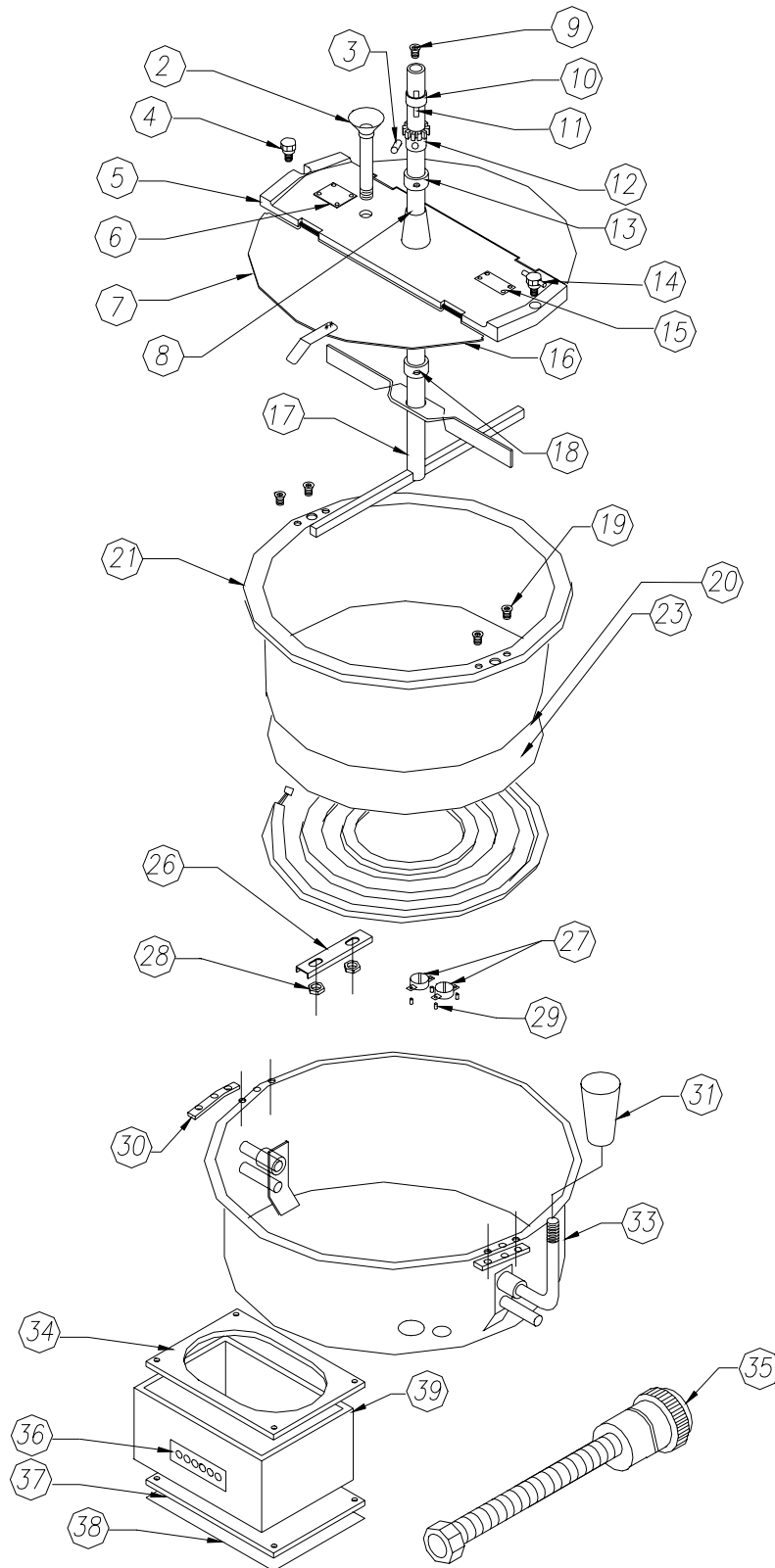



# KETTLE LEAD ASSEMBLY

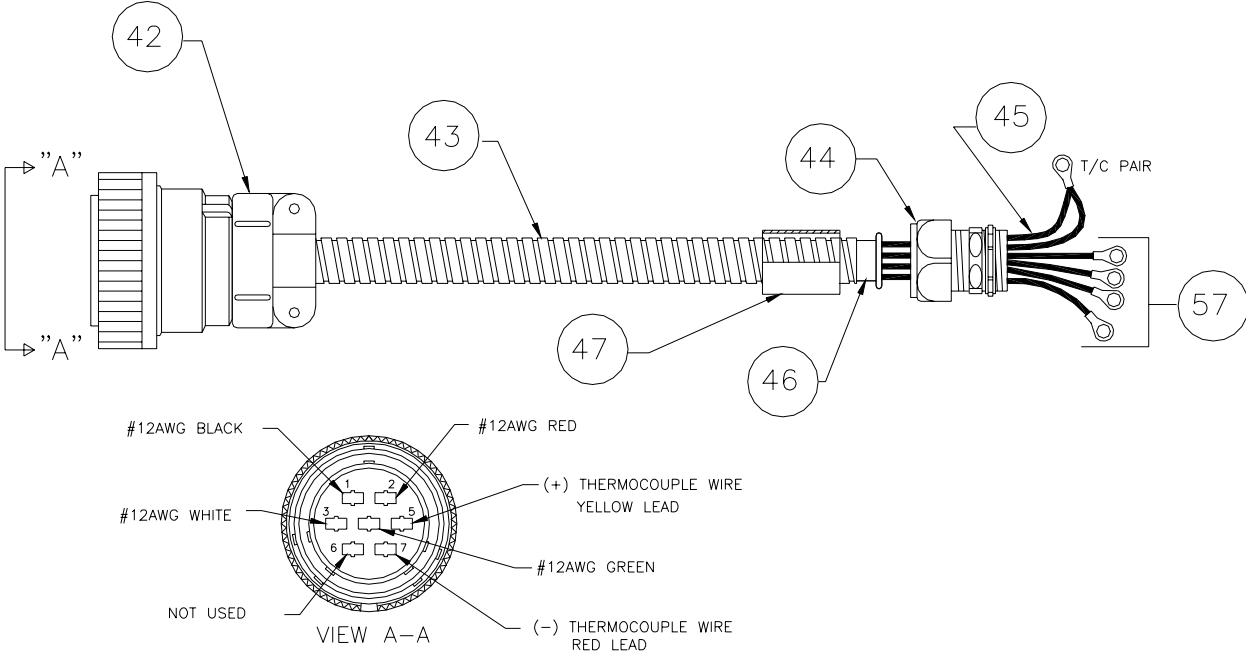

# KETTLE WIRING DIAGRAM

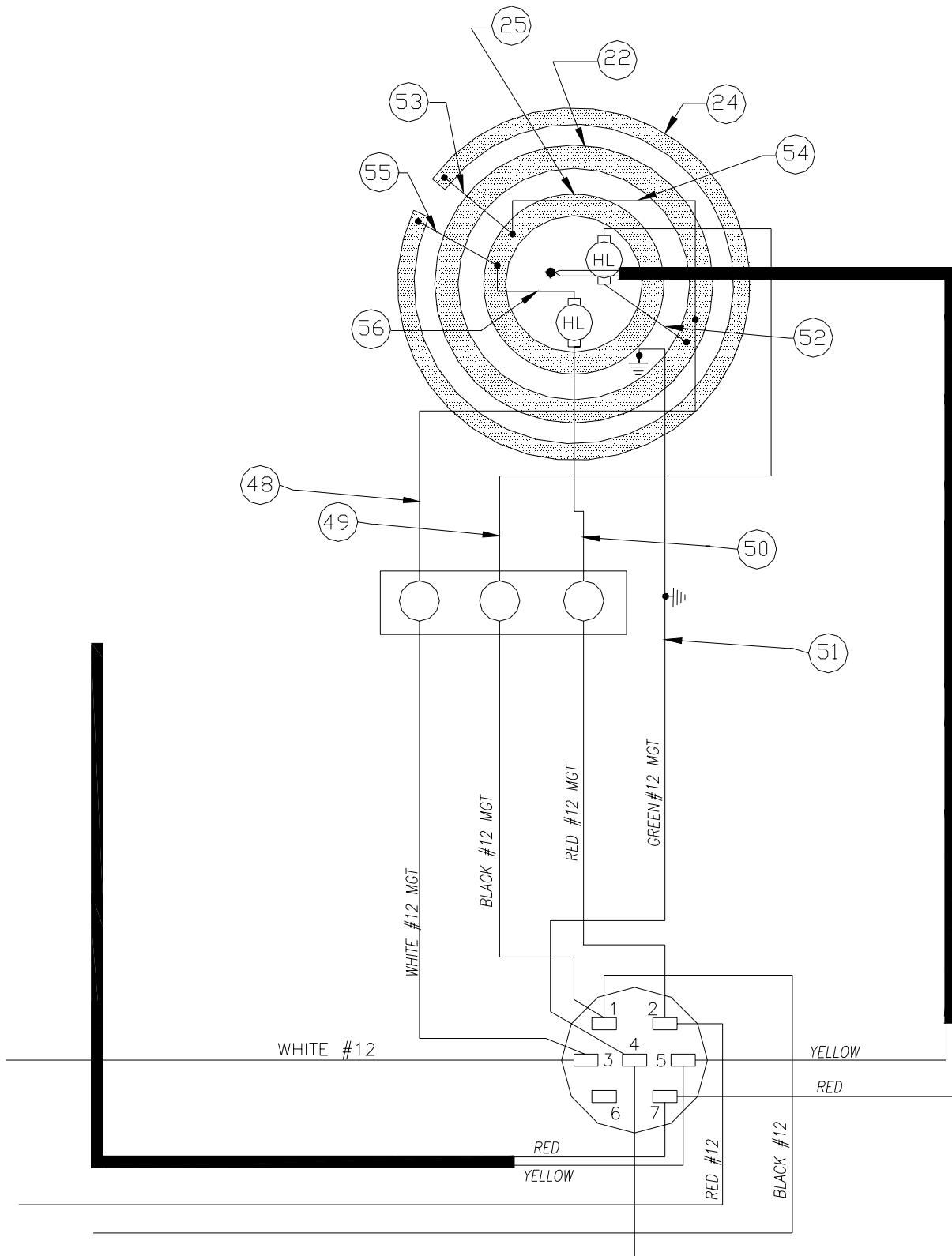

# ELECTRICAL SCHEMATIC

