

FILM-TECH

THE INFORMATION CONTAINED IN THIS ADOBE ACROBAT PDF FILE IS PROVIDED AT YOUR OWN RISK AND GOOD JUDGMENT.

THESE MANUALS ARE DESIGNED TO FACILITATE THE EXCHANGE OF INFORMATION RELATED TO CINEMA PROJECTION AND FILM HANDLING, WITH NO WARRANTIES NOR OBLIGATIONS FROM THE AUTHORS, FOR QUALIFIED FIELD SERVICE ENGINEERS.

IF YOU ARE NOT A QUALIFIED TECHNICIAN, PLEASE MAKE NO ADJUSTMENTS TO ANYTHING YOU MAY READ ABOUT IN THESE ADOBE MANUAL DOWNLOADS.

WWW.FILM-TECH.COM



Developed specifically for the unique requirements of professional motion picture playback, the SC-443 extends QSC's commitment to the cinema market. As a member of the DCS Digital Cinema Speaker Series, the SC-443 is a three-way, selectable bi or tri-amplified screen channel loudspeaker system comprised of three main units—the MH-1075 high frequency system and dual LF-4215 low frequency systems.

The MH-1075 Mid-High system features a high output, horn loaded 10" midrange cone driver and a 3" (75mm) titanium diaphragm compression driver mounted to an adjustable pan and tilt bracket. The MH-1075 includes a driver protection network and a passive crossover for bi-amp operation. Power limiter circuitry protects the high frequency driver from overpowering. The MH-1075 provides extended frequency coverage for the critical midrange band. A high power 10" cone driver allows operation as low as 250 Hz and the advanced phase plug coupling permits a crossover point of up to 1800 Hz to the high frequency horn. This ensures that most of the dialog range is reproduced by a single element, for unmatched intelligibility.

The LF-4215 dual 15" (381mm) low-frequency enclosures are designed specifically to address the extended low-frequency response required for cinema applications. The dual LF-4215's cover the frequency range from 35 Hertz to 250 Hertz. Close Coupled Woofers (CCW), with their tight spacing between woofers, improves coupling and keeps coverage angles wide over a greater frequency range than more widely spaced designs.

The SC-443 is designed for ease of installation. The MH-1075 components come pre-assembled to reduce field assembly time. Three bolts are all that are required to secure the MH-1075 to the top of the LF-4215 enclosure.

Key Features:

- Three-way selectable, bi or tri-amplified screen channel system
- MH-1075 provides 90° horizontal x +20° to -30° vertical coverage
- LF-4215 is constructed of MDF and features single woofer chambers
- Low-distortion waveguides provide highly articulate dialogue
- Shallow depth (20") facilitates installation



Specifications		SC-443	
Nominal Coverage	90° horizontal x +20 to -30° vertical		
Frequency Range	32-16 kHz (-6 dB)		
Crossover Frequency	250 & 1700 Hz, 24 dB per octave		
	(2) LF-4215	MH-1075	
Impedance	4 ohms EA.	8 ohms	
Sensitivity 1 watt/1 meter, half space	102.5 dB	Bi-amp 106dB	Tri-amp MF 105 dB HF 107.5 dB
Maximum Input Power (8 hours of 6db crest factor IEC 268 noise spectrum) (2 hours of 6db crest factor pinknoise, 50 - 20,000 Hz, AES method)	[1] 800 watts RMS EA.	[2] 250 watts RMS	275 watts RMS 80 watts RMS
Recommended Amplifier Power	1000 watts RMS EA. 1600 watts RMS maximum EA.	350 watts RMS 800 watts RMS maximum	
Recommended Processing	Subsonic filter below 30 Hz, >18 dB per octave	4th order LR crossover at 250 & 1700 Hz via QSC DCM or QSCControl.net	
Connectors	Barrier strip screw terminals accept up to #10 AWG stranded wire, four terminals-two inputs, two parallel outputs	Barrier strip screw terminals accept up to #10 AWG stranded wire	
Transducers	Four 15" (381mm) high efficiency, extended bass woofers featuring 4" copper voice coils	10" high efficiency mid range, 1.5" (38mm) exit, 2.5" titanium diaphragm compression driver	
Enclosure	Quasi B4 alignment, ported enclosure with fully flared ports, symmetrical port design, tuned to 36 Hz, constructed of MDF and heavily braced. Features vandal resistant woofer mounting bolts	Tilt/Pan Bracket ±10° vertical tilt ±10° horizontal pan	
Dimensions	30" wide x 72" high x 20.3" deep (762mm x 1820mm x 516mm)	30" wide x 39" high x 20" deep (762mm x 990mm x 508mm)	
Net Weight	344 lbs/156 kg	85 lbs/39 kg	
System Weight	429 lbs/195 kg		
Baffle Cut-Out	111.6" x 32"		

[1] Maximum input power tested in accordance with IEC 268-5 recommendations, 50 Hz - 20 kHz band limiting, 6 dB signal crest factor.
 [2] Maximum input power tested in accordance with IEC 268-5 recommendations, 200 Hz - 2 kHz band limiting, 6 dB signal crest factor.

SC-443 Enclosure Dimensions

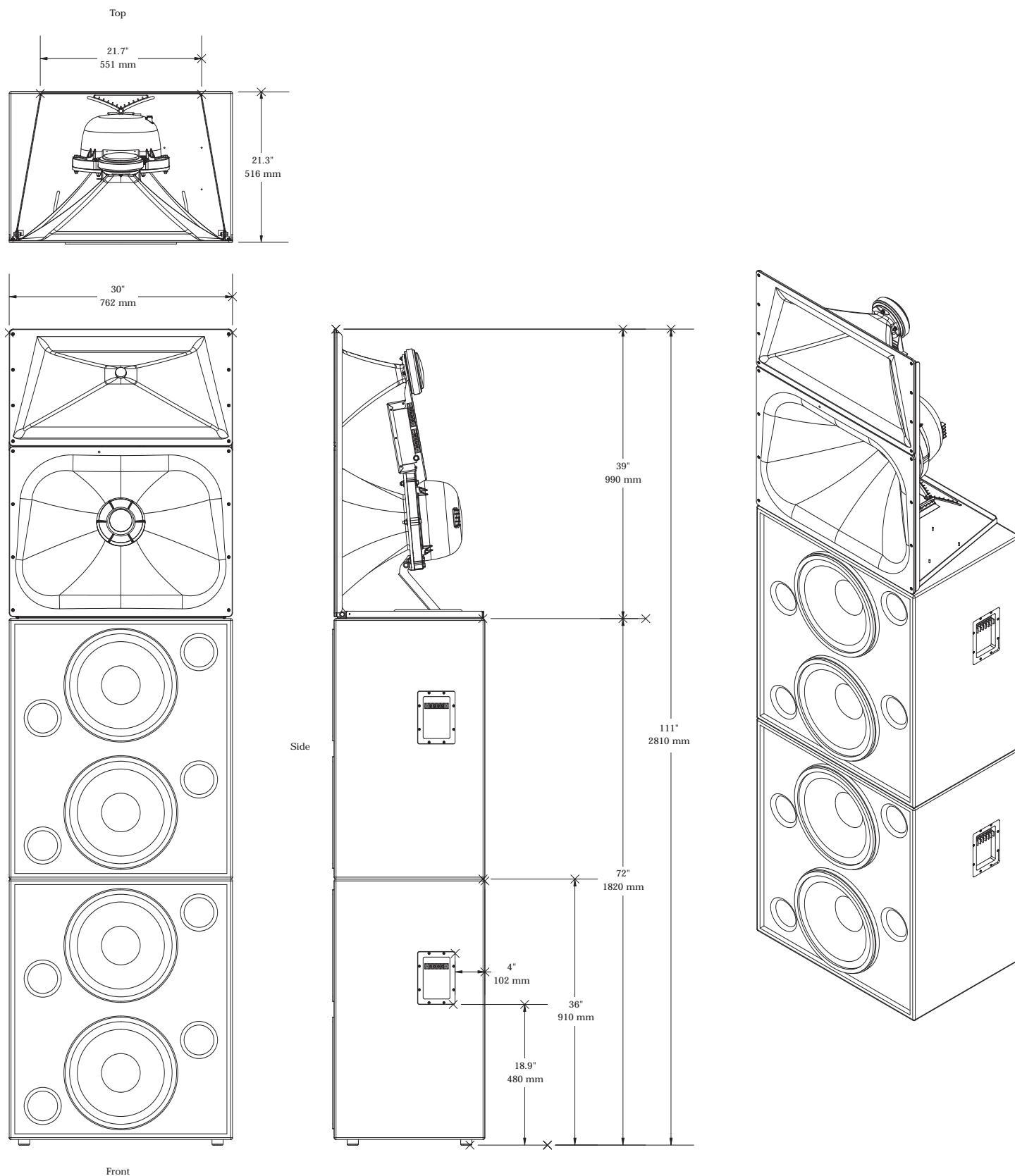

Specifications subject to change without notice.



1675 MacArthur Blvd., Costa Mesa, CA, 92626 USA
 Main Number (714) 754-6175 Sales & Marketing (714) 957-7100 or toll free (USA only) (800) 854-4079
 Customer Service (714) 957-7150 or toll free (USA only) (800) 772-2834

Cinema Mid-High Loudspeaker System User Manual

MH-1063 10" (254mm) mid, 2.5" (63mm) compression driver

MH-1075 10" (254mm) mid, 3.0" (75mm) compression driver

Introduction

The MH-1063 and MH-1075 "mid-high packs" provide the mid and high frequency components of three-way screen channel loudspeaker systems for high performance cinema applications. They were designed to operate with and be directly mounted on QSC's cinema low frequency enclosures.

Mid frequencies are reproduced with a 10" (254mm) high-efficiency, phase-ring loaded driver mounted on a custom designed cinema horn. The high-frequency driver is a large format, 2.5" (63mm, MH-1063) or 3.0" (75mm, MH-1075) titanium diaphragm compression driver mounted on a custom high-frequency cinema horn. The high frequency horn is a low-distortion waveguide providing highly articulate dialogue without coloration associated with conventional horn loudspeakers. Both horns feature broad horizontal and vertical coverage angles to ensure coverage of every seat in the auditorium. The driver assemblies are mounted on an adjustable pan and tilt bracket that has an integral aiming sight, simplifying installation.

The MH-1063 and MH-1075 loudspeakers include a driver protection and crossover network to assure reliable operation. DC blocking capacitors protect against DC or low-frequency signals that could damage an unprotected driver. Power limiter circuitry protects the driver from over-powering and an 18dB/octave crossover seamlessly blends the high and mid frequency elements. Outboard processing is required to form the crossover between the LF and MH loudspeakers.

Bi-amp or tri-amp operation is possible using a selector switch mounted on the connections panel. The bi-amp setting provides a passive crossover network between mid and high drivers. Separate amplifiers and an active crossover are required for the low frequency channel and the mid-high channel. Tri-amp setting disables the internal mid-high crossover and each driver is driven independently by its own amplifier and active crossover; one for the low, one for the mid, and one for the high frequencies.

The MH-1063 and MH-1075 components come pre-assembled to reduce field assembly time. Three bolts are all that are required to secure the mid-high assembly to the top of a QSC low frequency enclosure.

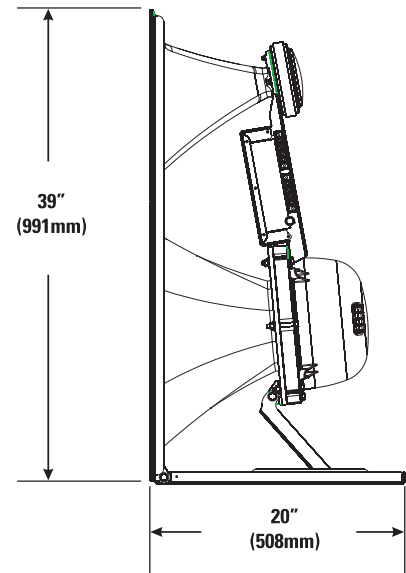
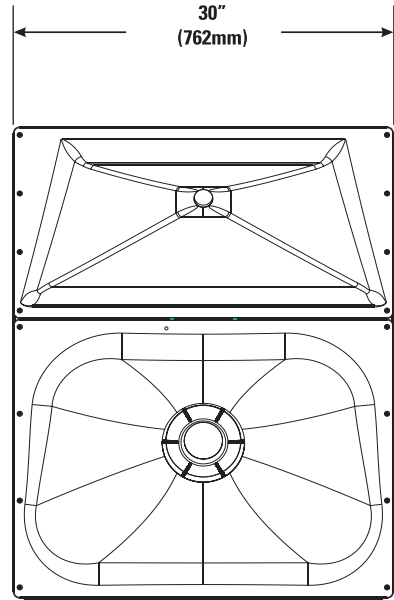
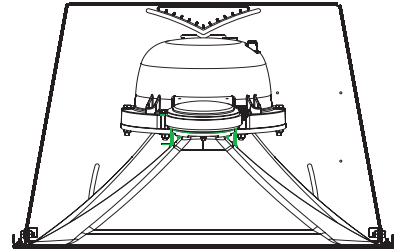

Install in accordance with QSC Audio Product's instructions and a licensed, professional engineer. Only use attachments, mounts, accessories, or brackets specified by QSC Audio Products, Inc. Refer all servicing to qualified personnel. Servicing is required when the apparatus has been damaged in any way.



WARNING! Before placing, installing, rigging, or suspending any speaker product, inspect all hardware, suspension, cabinets, transducers, brackets and associated equipment for damage. Any missing, corroded, deformed or non-load rated component could significantly reduce the strength of the installation, placement, or array. Any such condition severely reduces the safety of the installation and should be immediately corrected. Use only hardware which is rated for the loading conditions of the installation and any possible short-term unexpected overloading. Never exceed the rating of the hardware or equipment. Consult a licensed, professional engineer when any doubt or questions arise regarding a physical equipment installation.



Mounting

Attaching to Low Frequency Enclosure

The mid-high loudspeaker assembly attaches to the top of the QSC low frequency cabinet with three 5/16-18 bolts, 0.75" long, with lock washers. This hardware ships installed on the low frequency cabinet. We recommend the use of serviceable thread locking compound when installing the bolts to prevent loosening due to vibration. Do not fully tighten the mounting hardware before aiming (see below).

Aiming

Aim the horn in the horizontal plane (pan) before tightening the attachment hardware. Adjust the vertical tilt with the mid-high vertical adjustment bracket. The mid-high assembly is equipped with an aiming sight to assist in achieving desired coverage quickly and easily. For typical applications, the aim point should be the center seat in the back row of the auditorium. If the cinema screen has already been installed, a flashlight placed at the desired aiming point can be seen through the screen perforations in a darkened auditorium.

Where the sight holes are located:

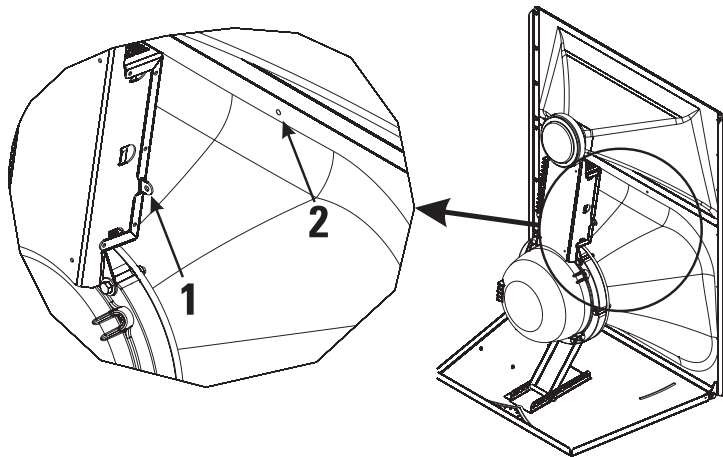

How to use the sights:

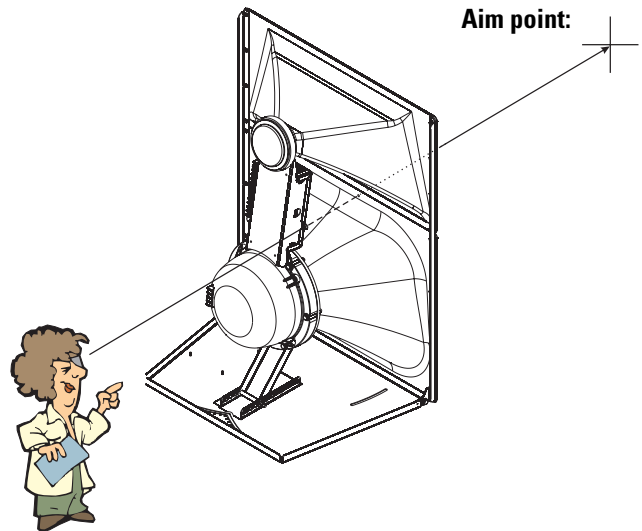

Settings

BI-AMP / TRI-AMP Operating Mode Selection

Set the operating mode selector switch to **BI-AMP** or **TRI-AMP**, depending on your application setup.

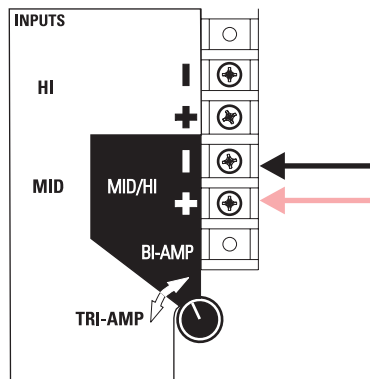

BI-AMP-When set to **BI-AMP**, the MH-1063 and MH-1075 accepts mid-high frequency signals on one set of inputs and uses an internal crossover network between the mid- and high-frequency drivers. The signal applied to the mid-high loudspeaker assembly must not contain low-frequency content (below 200 Hz).

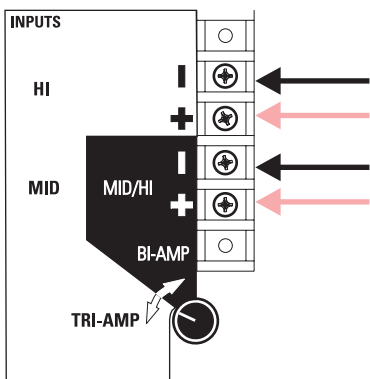

TRI-AMP- When set to **TRI-AMP**, the MH-1063 and MH-1075 accepts separate mid- and high-frequency signals on two sets of inputs. The internal crossover network is bypassed and only the protective circuitry for the H.F. driver remains. Each of the driver's signals must have the appropriate signal processing before operating.



**Do not connect amplifiers directly to the driver inputs!
Always use the input terminal strip.**

Connections

INPUT Terminals

The MH-1063 and MH-1075 have barrier strip screw terminals that accept up to #10 AWG (5.3mm²) stranded loudspeaker wire. Observe proper polarity. Use the largest wire size and shortest wire length for the application.

OUTPUT Terminals

The **OUTPUT** terminals are factory-connected to the drivers. These terminals should **ONLY** be connected to their respective driver. Do not connect signals to these terminals as all protection and equalization circuitry will be bypassed.



NOTE! Maintain proper loudspeaker connection polarity throughout the entire system for maximum performance. Do not apply full range signal to the MH-1063 / MH-1075! There is a mid-high passive crossover for bi-amp mode only. There is no crossover connected when operating in tri-amp mode. A protection network is always active. All required signal processing must be done before the signal is applied to the loudspeaker. Do not connect any signal to the upper sets of OUTPUT terminals.

BI-AMP mode connections- Ensure the mode switch is set to **BI-AMP**, connect the input to the MH-1063 / MH-1075 to the lower set of input terminals marked "**BI-AMP + -**".

BI-AMP Mode- one amplifier channel is used for the low frequency cabinet and one amplifier channel for the mid-high assembly. The MH-1063 / MH-1075 mode switch is set to **BI-AMP**. Active crossovers are used before amplification. The mid-high assembly provides a passive crossover between the mid and high frequency drivers.

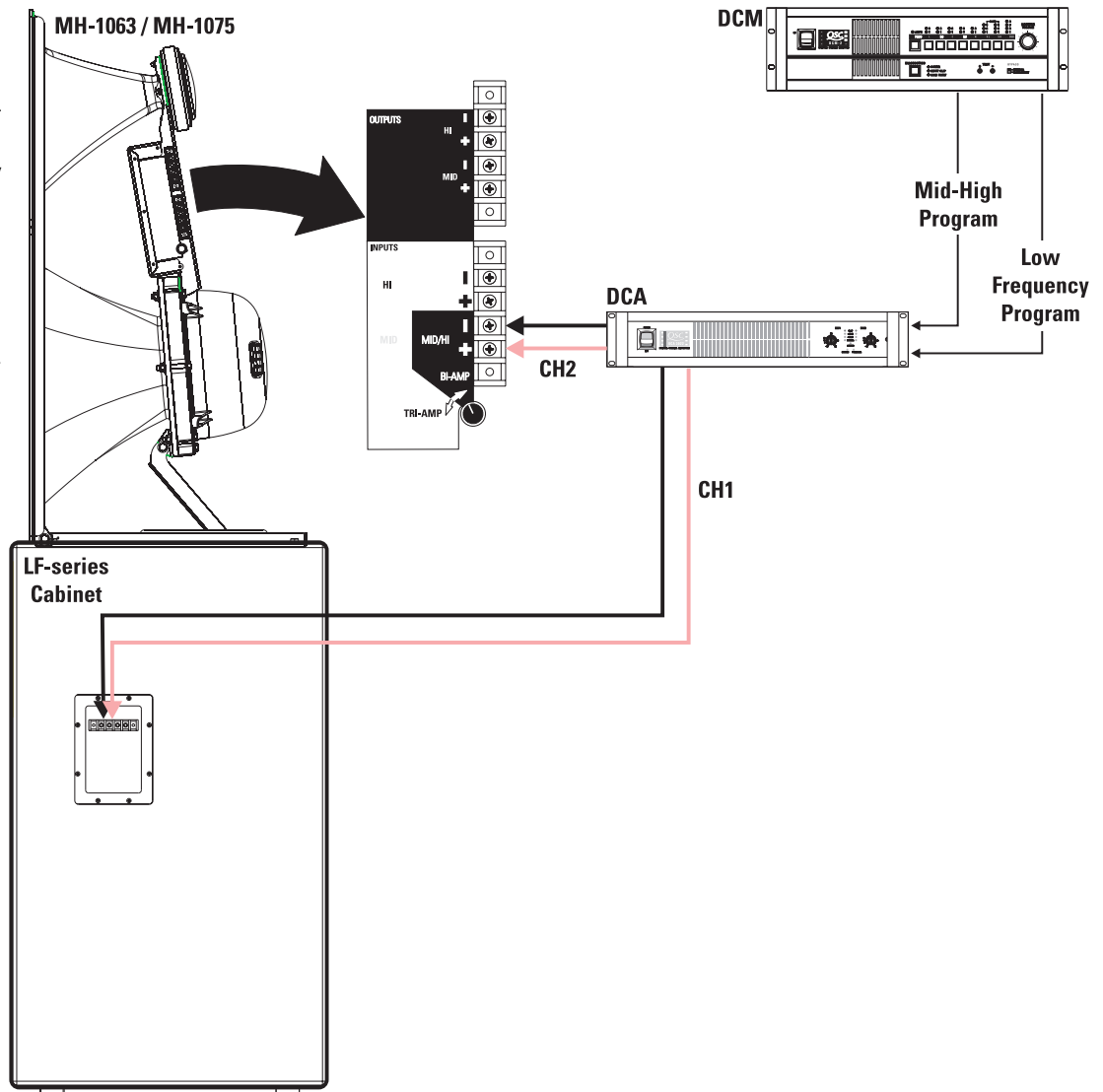

Connections (continued)

TRI-AMP mode connections- When the mode switch is set to **TRI-AMP**, connect the high frequency signal to the terminals marked "INPUT HI + -" and the mid frequency signal to the terminals marked "INPUT MID + -".

TRI-AMP Mode- one amplifier channel is used for the low frequency cabinet, one amplifier channel for the mids, and one amplifier channel for the high frequencies. The MH-1063 / MH-1075 mode switch is set to **TRI-AMP**, bypassing the internal mid-high passive crossover. Active or passive crossovers are used before amplification. Power limiter and DC blocking remain active.

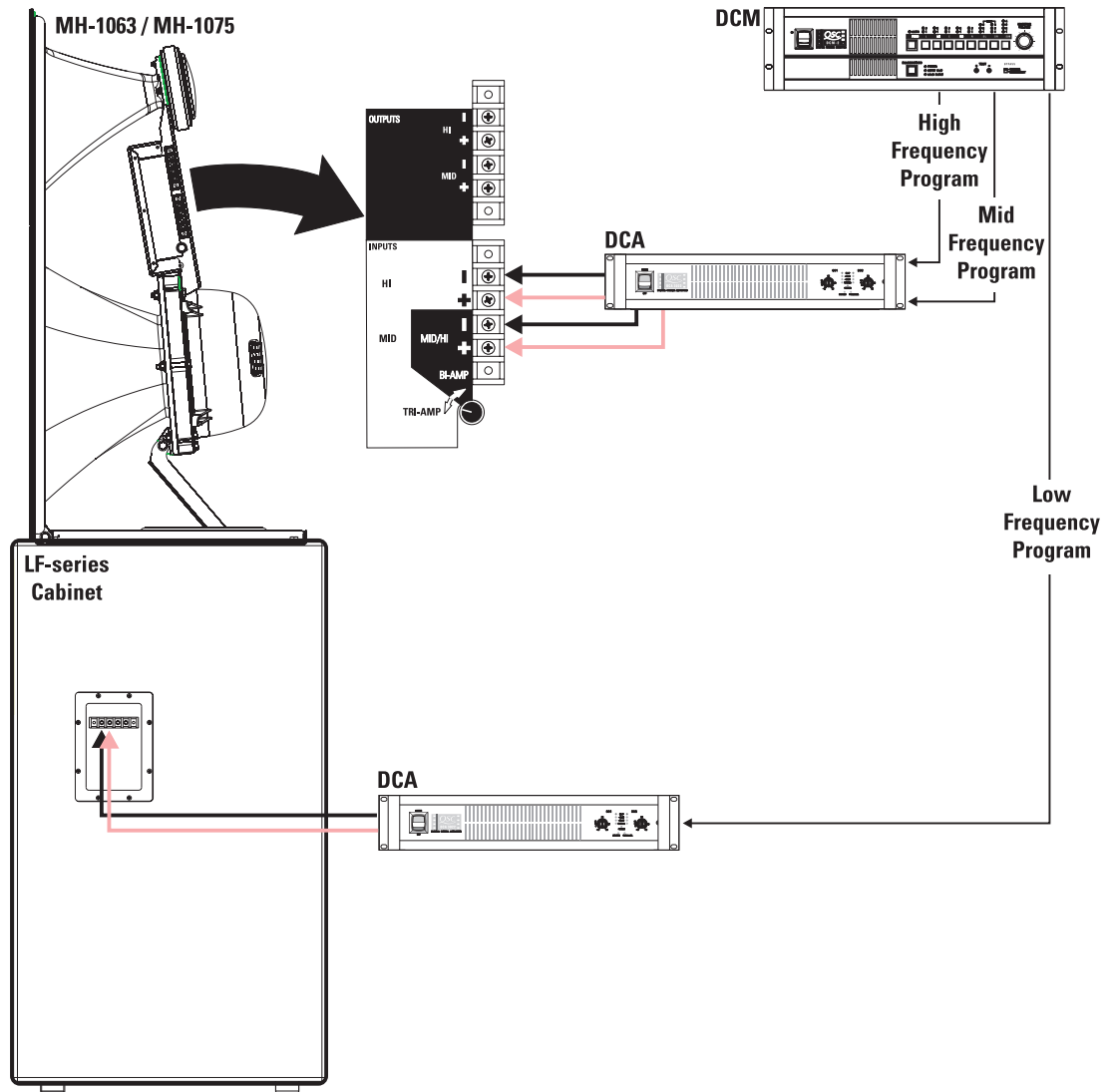

MH-1063 Specifications (subject to change without notice)

Freq. Range	180 - 15k (-6dB, full space)
Nominal Coverage	90° horizontal X +20 to -30° vertical (50° total, adjustable mount provides for vertical plane adjustments. The horizontal plane can be adjusted by altering mounting position on the low frequency enclosure before tightening bolts.
DI:	9 dB (400 to 16k Hertz average)
Q:	8 (400 to 16k Hertz average)
Max. Output:	[Tri-amp mode] Mid Freq. 135.5 dB SPL calculated peak, 1m, full space [Tri-amp mode] High Freq. 131.5 dB SPL calculated peak, 1m, full space [Bi-amp mode] 135 dB SPL calculated peak, 1m, full space
Impedance:	[Bi-amp mode] 8 ohms nominal 7.9 ohms minimum at 1500 Hertz 91 ohms maximum at 150 Hertz
Maximum Input Power	[Tri-amp mode] Mid Freq. 275 W (AES method, 2 hrs.) [Tri-amp mode] High Freq. 60 W (AES method, 2 hrs.) [Bi-amp mode] 250 W (IEC method, 8 hrs.)
Sensitivity	[Tri-amp mode] Mid Freq. 105 dB SPL, 1 watt, 1 meter [Tri-amp mode] High Freq. 107.5 dB SPL, 1 watt, 1 meter [Bi-amp mode] 135 dB SPL, 1 watt, 1 meter
Crossover Frequency	[Tri-amp mode] 250 Hertz or higher, 24dB/octave and 1.7k Hertz, 24dB/octave [Bi-amp mode] 250 Hertz or higher, 24dB/octave
Crossover Network	1.7k Hertz, 18 dB/octave electrical slope, HF driver power limiting circuit (never disrupts continuity). Switchable operation between Bi-Amp and Tri-amp operation. Tri-amp setting removes crossover circuit from signal, leaving power limiter and DC blocking capacitors.
Connectors	Barrier strip screw terminals accept up to #10 AWG stranded wire. Four terminals, two HF input and two MF input (for Tri-amp mode operation).
Transducers	MF: 10" high efficiency midrange, phase-ring loaded. HF: 1.5" (38mm) exit, 2.5" (63.5mm) titanium diaphragm compression driver.
Mounting Hardware:	Attaches to top of the low frequency cabinet using three 5/16"-18 x 3/4" long bolts.
Size	39" high x 30" wide x 20" deep (991 x 762 x 508mm)
Weight	85 lb. (39 kg) net

MH-1075 Specifications (subject to change without notice)

Freq. Range	180 - 15k (-6dB, full space)
Nominal Coverage	90° horizontal X +20 to -30° vertical (50° total, adjustable mount provides for vertical plane adjustments. The horizontal plane can be adjusted by altering mounting position on the low frequency enclosure before tightening bolts.
DI:	9 dB (400 to 16k Hertz average)
Q:	8 (400 to 16k Hertz average)
Max. Output:	[Tri-amp mode] Mid Freq. 135.5 dB SPL calculated peak, 1m, full space [Tri-amp mode] High Freq. 133 dB SPL calculated peak, 1m, full space [Bi-amp mode] 135.5 dB SPL calculated peak, 1m ,full space
Impedance:	[Bi-amp mode] 8 ohms nominal 6.4 ohms minimum at 1500 Hertz 91 ohms maximum at 150 Hertz
Maximum Input Power	[Tri-amp mode] Mid Freq. 275 W (AES method, 2 hrs.) [Tri-amp ode] High Freq. 80 W (AES method, 2 hrs.) [Bi-amp mode] 250 W (IEC method, 8 hrs.)
Sensitivity	[Tri-amp mode] Mid Freq. 105 dB SPL, 1 watt, 1 meter [Tri-amp mode] High Freq. 108 dB SPL, 1 watt, 1 meter [Bi-amp mode] 135.5 dB SPL, 1 watt, 1 meter
Crossover Frequencies	[Tri-amp mode] 250 Hertz or higher, 24dB/octave and 1.7k Hertz, 24dB/octave [Bi-amp mode] 250 Hertz or higher, 24dB/octave
Crossover Network	1.7k Hertz, 18 dB/octave electrical slope, HF driver power limiting circuit (never disrupts continuity). Switchable operation between Bi-Amp and Tri-amp operation. Tri-amp setting removes crossover circuit from signal, leaving power limiter and DC blocking capacitors.
Connectors	Barrier strip screw terminals accept up to #10 AWG stranded wire. Four terminals, two HF input and two MF input (for Tri-amp mode operation).
Transducers	MF: 10" high efficiency midrange, phase-ring loaded. HF: 1.5" (38mm) exit, 3" (76mm) titanium diaphragm compression driver.
Mounting Hardware:	Attaches to top of the low frequency cabinet using three 5/16"-18 x 3/4" long bolts.
Size	39" high x 30" wide x 20" deep (991 x 762 x 508mm)
Weight	85 lb. (39 kg) net

MH-1063 SPL and Impedance vs. Frequency

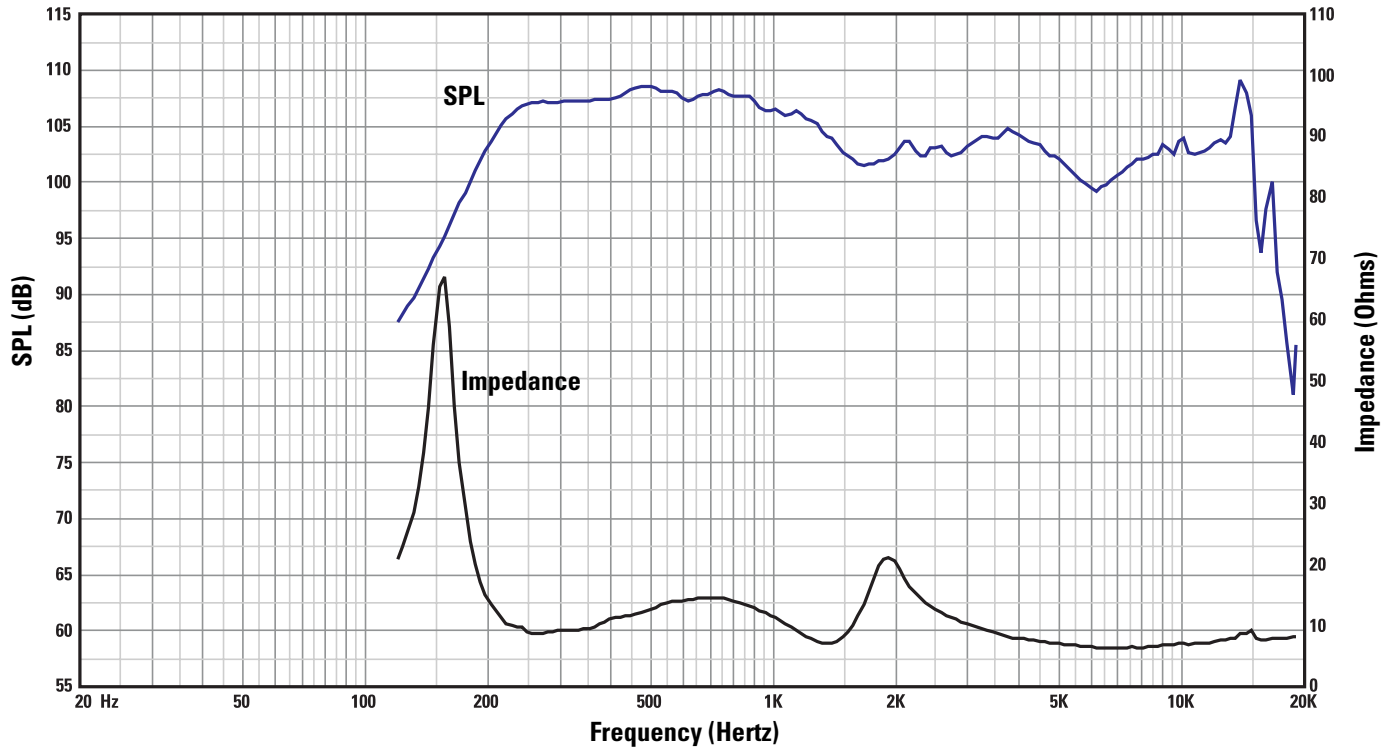

MH-1075 SPL and Impedance vs. Frequency

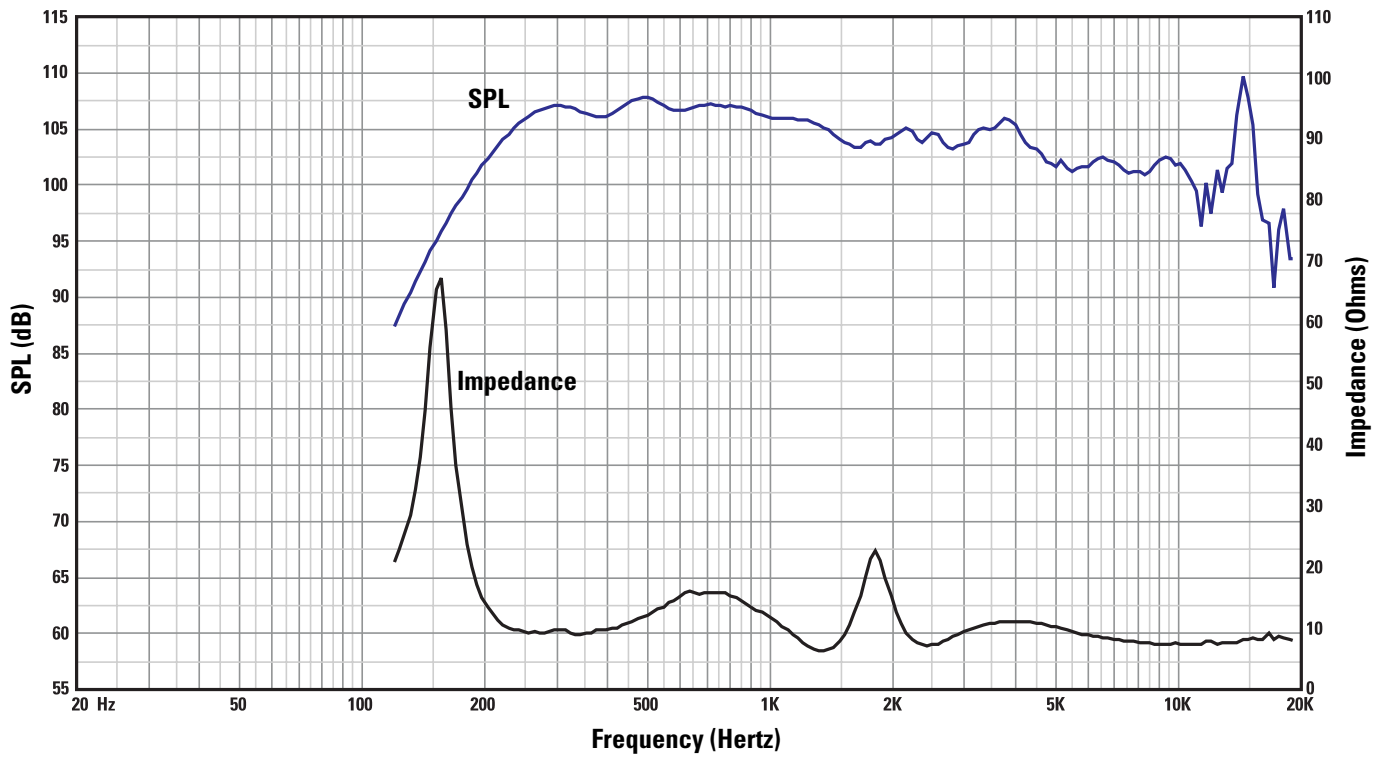

Warranty (USA only; other countries, see your dealer or distributor)

Disclaimer

QSC Audio Products, Inc. is not liable for any damage to amplifiers, or any other equipment that is caused by negligence or improper installation and/or use of this loudspeaker product.

QSC Audio Products 3 Year Limited Warranty

QSC Audio Products, Inc. ("QSC") guarantees its products to be free from defective material and / or workmanship for a period of three (3) years from date of sale, and will replace defective parts and repair malfunctioning products under this warranty when the defect occurs under normal installation and use - provided the unit is returned to our factory or one of our authorized service stations via pre-paid transportation with a copy of proof of purchase (i.e., sales receipt). This warranty provides that the examination of the return product must indicate, in our judgment, a manufacturing defect. This warranty does not extend to any product which has been subjected to misuse, neglect, accident, improper installation, or where the date code has been removed or defaced. QSC shall not be liable for incidental and/or consequential damages. This warranty gives you specific legal rights. This limited warranty is freely transferable during the term of the warranty period.

Customer may have additional rights, which vary from state to state.

In the event that this product was manufactured for export and sale outside of the United States or its territories, then this limited warranty shall not apply. Removal of the serial number on this product, or purchase of this product from an unauthorized dealer, will void this limited warranty. Periodically, this warranty is updated. To obtain the most recent version of QSC's warranty statement, please visit www.qscaudio.com. Contact us at 800-854-4079 or visit our website at www.qscaudio.com.

Contacting QSC Audio Products

Mailing address: QSC Audio Products, Inc.
1675 MacArthur Boulevard
Costa Mesa, CA 92626-1468 USA

Telephone Numbers:

Main Number (714) 754-6175

Sales & Marketing (714) 957-7100 or toll free (USA only) (800) 854-4079

Customer Service (714) 957-7150 or toll free (USA only) (800) 772-2834

Facsimile Numbers:

Sales & Marketing Fax (714) 754-6174

Customer Service Fax (714) 754-6173

World Wide Web: www.qscaudio.com

E-mail: info@qscaudio.com

service@qscaudio.com





1675 MacArthur Blvd., Costa Mesa, CA, 92626 USA
 Main Number (714) 754-6175 Sales & Marketing (714) 957-7100 or toll free (USA only) (800) 854-4079
 Customer Service(714) 957-7150 or toll free (USA only) (800) 772-2834

Cinema Loudspeaker Systems User Manual

LF-4215 Low Frequency Loudspeaker

Introduction

The LF-4215 dual 15" (381mm) low frequency enclosure is designed specifically for cinema applications. Meeting cinema requirements for extended low frequency response differentiates the LF-4215 from more conventional "rock-and-roll" woofer systems. The LF-4215 covers the frequency range from 35 Hertz to 1000 Hertz, depending upon the high frequency system requirements. Close Coupled Woofers (CCW), with its tight spacing between woofers, improves coupling and keeps coverage angles wide over a greater frequency range than more widely spaced designs.

The two custom 400 watt, 15" transducers were developed especially for cinema use. They feature extremely large 4" (100mm) voice coils and a multi-vented pole piece to ensure cool operation, even at high power levels. Cooler temperatures increase transducer lifespan and decrease the problem of power compression at high power. An undercut pole piece ensures the voice coil operates in a Symmetrical Magnetic Gap (SMG), reducing second harmonic distortion.

The enclosure is constructed of high quality MDF panels and features Single Woofer Chambers (SWC, separate chambers for each transducer). In the rare event of a transducer failure, this prevents over-excursion of the remaining transducer caused by improper box loading.

Large, Fully Radiused Ports (FRP) ensure smooth air flow through the ports, especially at higher power. This prevents potentially audible port turbulence noise. Both internal and external port openings are fully radiused.

With Symmetrical Port Loading (SPL), bass ports are evenly spaced on each side of the transducers, making internal pressure more uniform across the back surface of the transducer. This prevents the cone from being displaced to one side or another by unbalanced forces, reducing the chance of driving the voice coil out of the center of the gap at high power.

Three T-nuts in the top of the enclosure provide easy mounting of QSC's HF-75 high frequency system, or MH-1075 mid-high system.

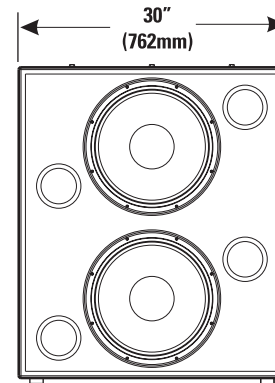
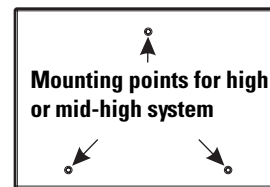
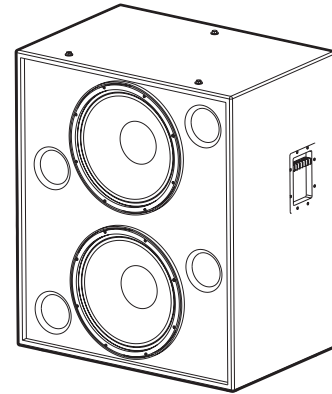

Enclosure is not designed to be suspended, flown, or rigged. Do not suspend, fly, or rig this enclosure.

This product is capable of producing sound pressure levels that can permanently damage human hearing. Always keep sound pressure levels in the listening area below levels that can damage human hearing.

Install in accordance with QSC Audio Product's instructions and a licensed, professional engineer. Only use attachments, mounts, accessories, or brackets specified by QSC Audio Products, Inc. Refer all servicing to qualified personnel. Servicing is required when the apparatus has been damaged in any way.



WARNING! Before placing, installing, rigging, or suspending any speaker product, inspect all hardware, suspension, cabinets, transducers, brackets and associated equipment for damage. Any missing, corroded, deformed or non-load rated component could significantly reduce the strength of the installation, placement, or array. Any such condition severely reduces the safety of the installation and should be immediately corrected. Use only hardware which is rated for the loading conditions of the installation and any possible short-term unexpected overloading. Never exceed the rating of the hardware or equipment. Consult a licensed, professional engineer when any doubt or questions arise regarding a physical equipment installation.

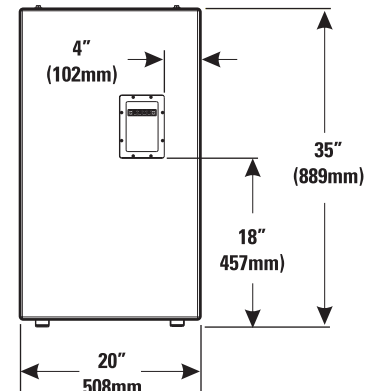

Connections

Normal Connection

The LF-4215 has barrier strip screw terminals for connection. The terminals accept up to #10 AWG stranded loudspeaker wiring. Use the largest wire size and shortest wire length possible for a given installation. Observe the polarity markings and keep polarity consistent throughout the system for best performance.

Normal Connection Example:

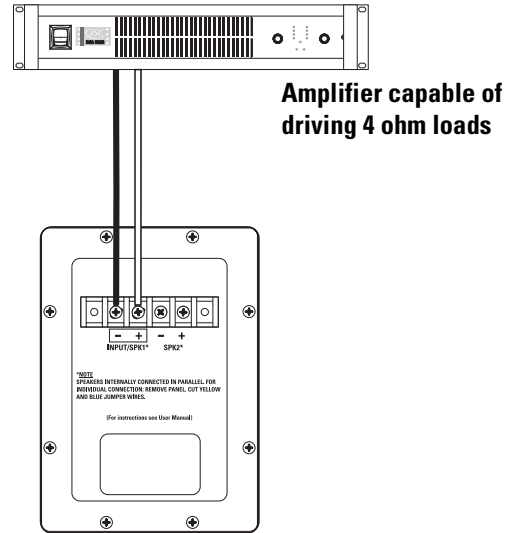

Parallel Connection of Second SB-5218

The terminals marker SPK2 may be used to connect another LF-4215 in parallel. Connect the wires as shown in the illustration, at right. Note: If the LF-4215's internal wiring has been modified in any way, this may not function. If this is the case, remove the terminal cup and verify the presence of the factory yellow jumper and blue jumper wires; remedy as required or have the loudspeaker serviced.

Parallel Connection Example:

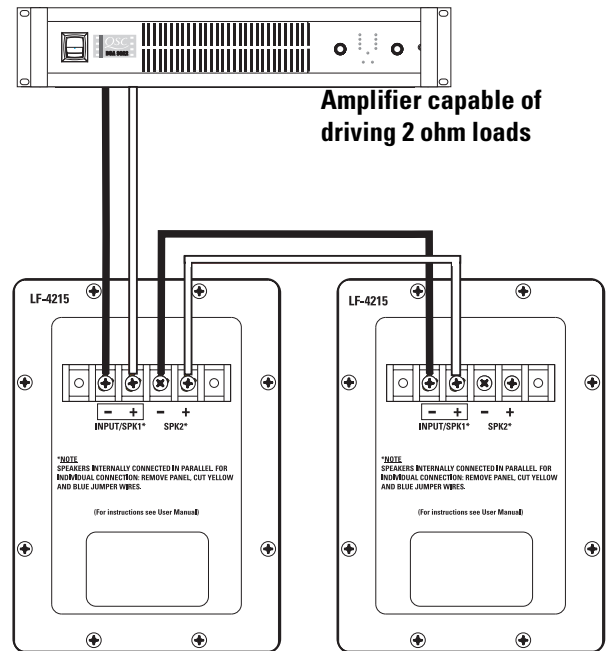

Individual Transducer Connection (requires modification)

The transducers are wired in parallel inside the enclosure. If individual transducer connection is required, remove the terminal cup and remove the yellow and the blue jumper wires that are connected between the SPK1 and SPK2 terminals. Replace the terminal cup and mark the enclosure with a note of the modification.

Individual Transducer Connection Example:

CAUTION! Requires removal of terminal cup and cutting of both the yellow and the blue jumper wires that connect the SPK1 and SPK2 terminals

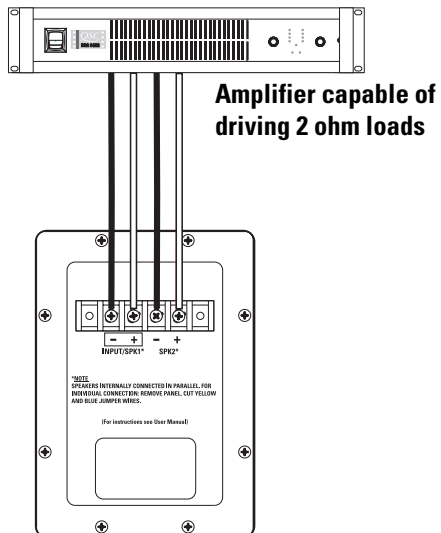

LF-4215 Specifications (subject to change without notice)

Frequency Range:	38 - 1300 Hertz (± 3 dB) 30 - 1400 Hertz useable range (-10 dB)
Nominal Coverage:	100° horizontal X 55° vertical at 600 Hertz
Maximum Output:	134.5 dB SPL calculated peak, 1 meter, half space, at rated rms power with 6 dB crest factor pink noise input, 25 - 250 Hertz. 128.5 dBA SPL calculated maximum continuous, 1 meter. The dBA scale is typically used to identify sound sources which can cause permanent hearing loss.
Impedance:	4 ohms nominal 3.4 ohms minimum , 150 Hertz 25 ohms maximum, 22 Hertz
Maximum Input Power:	800 watts rms (100 hours of 6 dB crest factor pink noise, 30 - 500 Hertz) 1000 watts rms (2 hours of 6 dB crest factor pink noise, 30 - 500 Hertz, AES method) recommended amplifier power capability- 1600 watts rms maximum into 4 ohms (per LF-4218)
Sensitivity:	99.5 dB half space, 93.5 dB full space, 35 - 1000 Hertz, 1 watt, 1 meter
Recommended Processing:	Subsonic filter below 30 Hertz, >18 dB per octave, maximum recommended crossover frequency is 1000 Hertz. QSC DSP configurations are available at www.qscaudio.com . Parameters for alternative processing hardware are available upon request.
Connectors:	Barrier strip screw terminals accept up to #10 AWG stranded wire. Four terminals: (two INPUT and two PARALLEL OUT). Drivers are internally wired in parallel. For independent transducer connection, remove blue jumper wire and yellow jumper wire on internal-side of terminal cup and mark enclosure accordingly.
Transducers:	Two 15" (381mm) high efficiency low frequency transducers featuring vented 4" (100mm) copper voice coils on Kapton® formers. High excursion/low distortion design, with extremely high power handling, and low thermal and port compression.
Enclosure:	Quasi B4 alignment, ported enclosure with fully flared ports, low turbulence symmetrical port design, tuned to 36 Hertz, constructed of medium density fibreboard and heavily braced. Features vandal resistant woofer mounting bolts.
Size:	30" wide X 35" high X 20" deep (762 mm X 889 mm X 508 mm)
Weight:	195 lbs. shipping, 172 lbs. net (88/78 kg.)

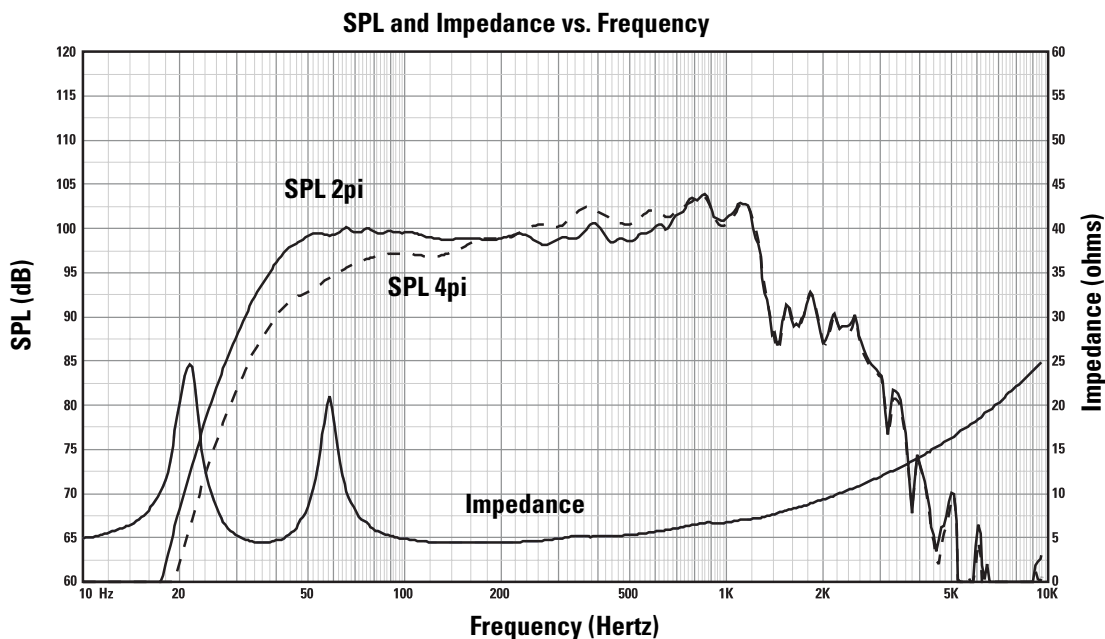

Warranty (USA only; other countries, see your dealer or distributor)

Disclaimer

QSC Audio Products, Inc. is not liable for any damage to amplifiers, or any other equipment that is caused by negligence or improper installation and/or use of this loudspeaker product.

QSC Audio Products 3 Year Limited Warranty

QSC Audio Products, Inc. ("QSC") guarantees its products to be free from defective material and / or workmanship for a period of three (3) years from date of sale, and will replace defective parts and repair malfunctioning products under this warranty when the defect occurs under normal installation and use - provided the unit is returned to our factory or one of our authorized service stations via pre-paid transportation with a copy of proof of purchase (i.e., sales receipt). This warranty provides that the examination of the return product must indicate, in our judgment, a manufacturing defect. This warranty does not extend to any product which has been subjected to misuse, neglect, accident, improper installation, or where the date code has been removed or defaced. QSC shall not be liable for incidental and/or consequential damages. This warranty gives you specific legal rights. This limited warranty is freely transferable during the term of the warranty period.

Customer may have additional rights, which vary from state to state.

In the event that this product was manufactured for export and sale outside of the United States or its territories, then this limited warranty shall not apply. Removal of the serial number on this product, or purchase of this product from an unauthorized dealer, will void this limited warranty. Periodically, this warranty is updated. To obtain the most recent version of QSC's warranty statement, please visit www.qscaudio.com. Contact us at 800-854-4079 or visit our website at www.qscaudio.com.

Contacting QSC Audio Products

Mailing address: QSC Audio Products, Inc.
1675 MacArthur Boulevard
Costa Mesa, CA 92626-1468 USA

Telephone Numbers:

Main Number (714) 754-6175

Sales & Marketing (714) 957-7100 or toll free (USA only) (800) 854-4079

Customer Service (714) 957-7150 or toll free (USA only) (800) 772-2834

Facsimile Numbers:

Sales & Marketing Fax (714) 754-6174

Customer Service Fax (714) 754-6173

World Wide Web: www.qscaudio.com

E-mail: info@qscaudio.com

service@qscaudio.com



QSC Audio Products, Inc. 1675 MacArthur Boulevard Costa Mesa, California 92626 USA
©2003, 2004, "QSC" and the QSC logo are registered with the U.S. Patent and Trademark Office.
Kapton® is a registered trademark of E.I. du Pont de Nemours and Company.



1675 MacArthur Blvd., Costa Mesa, CA, 92626 EE.UU.

Número principal +1 (714) 754-6175 Ventas y Comercialización +1 (714) 957-7100

o línea sin costo (sólo para EE.UU.) +1 (800) 854-4079

Servicio al cliente +1 (714) 957-7150 o gratis (sólo EE.UU.) +1 (800) 772-2834

Manual del usuario de los sistemas de altavoces para salas de cine

Altavoz de baja frecuencia LF-4215

Introducción

La caja doble de baja frecuencia de 15" (381 mm) del altavoz LF-4215 está diseñada específicamente para aplicaciones cinematográficas. El cumplimiento de los requisitos de las aplicaciones cinematográficas referentes a una respuesta extendida de baja frecuencia, es lo que distingue al altavoz LF-4215 de otros sistemas woofer tipo "rock-and-roll" más convencionales. El altavoz LF-4215 cubre un intervalo de frecuencia de 35 Hertzios a 1000 Hertzios, dependiendo de los requisitos del sistema de alta frecuencia. Woofers acoplados cerrados (Close Coupled Woofers, CCW), con su espacio estrecho entre los woofers, mejora el acoplamiento y mantiene la amplitud de los ángulos de cobertura sobre un mayor intervalo de frecuencia en comparación con diseños de espacio más grande.

Los dos transductores adaptados de 400 vatios y 15" se desarrollaron especialmente para su uso en salas de cine. Tienen bobinas de voz extremadamente grandes, de 4" (100 mm), y un polo multiventilado que asegura una operación fría, incluso a niveles altos de potencia. Las temperaturas más frías aumentan la vida útil del transductor y disminuyen el problema de compresión de la potencia a niveles altos de potencia. Un polo proyectado asegura que la bobina de voz opere en un campo magnético simétrico (Symmetrical Magnetic Gap, SMG), reduciendo la segunda deformación armónica.

La caja esta construida con paneles MDF (cartón duro de densidad media) de alta calidad y tiene cámaras de woofer sencillo (Single Woofer Chambers, SWC, cámaras separadas para cada transductor). En el raro evento de falla del transductor, esto previene la excursión excesiva del transductor remanente causada por la carga inadecuada de la caja.

Los grandes puertos totalmente redondeados (Fully Radiused Ports, FRP) aseguran un flujo uniforme de aire a su través, especialmente a niveles mayores de potencia. Esto evita ruido de turbulencia en el puerto potencialmente audible. Ambas aberturas del puerto, la interna y la externa, están totalmente redondeadas.

Con la carga simétrica de los puertos (Symmetrical Port Loading, SPL), los puertos de graves están igualmente separados a cada lado de los transductores, haciendo que la presión interna sea más uniforme a través de la superficie posterior del transductor. Esto evita que el cono sea desplazado de un lado a otro por fuerzas no equilibradas, reduciendo la probabilidad de impulsar la bobina de voz fuera del centro del espacio a altos niveles de potencia.

Tres tuercas en T en la parte superior de la caja permiten el montaje fácil del sistema de alta frecuencia HF-75 o del sistema de frecuencia media alta MH-1075, ambos de QSC.

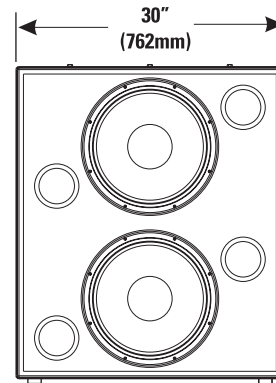
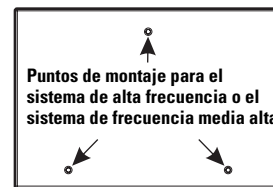
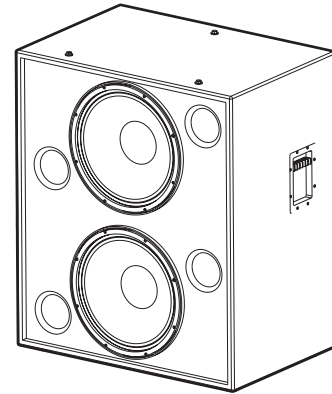

La caja no esta diseñada para montarse suspendida, en voladizo ni sobre arneses. No suspenda esta caja, no la monte en voladizo ni sobre arneses.

Este producto es capaz de producir niveles de presión del sonido que pueden causar daños permanentes al oído humano. Siempre mantenga los niveles de presión del sonido en un área de audición con un nivel menor que el que provoca daños al oído humano.

Instale de acuerdo con las instrucciones de QSC Audio Products y de un ingeniero profesional con la debida licencia. Sólo use piezas, montajes, accesorios o soportes especificados por QSC Audio Products, Inc. Refiera todo el servicio a personal calificado. Cuando el aparato haya sido dañado de alguna manera, es necesario proporcionarle servicio.



¡ADVERTENCIA! Antes de colocar, instalar, montar o suspender cualquier producto de altavoz, inspeccione todo el equipo físico, la suspensión, los armarios, los transductores, los soportes y el equipo asociado para detectar la existencia de daños. Cualquier componente faltante, corroido, deformado, o sin carga nominal podría reducir significativamente la resistencia de la instalación, la colocación o la configuración. Cualquier condición de este tipo reduce gravemente la seguridad de la instalación y debe corregirse de inmediato. Use sólo herraje que esté clasificado para las condiciones de carga de la instalación y cualquier posible carga excesiva a corto plazo inesperada. Nunca exceda el valor nominal del equipo físico ni del dispositivo. Consulte a un ingeniero profesional con la debida licencia cuando surjan dudas o preguntas referentes a la instalación física del equipo.

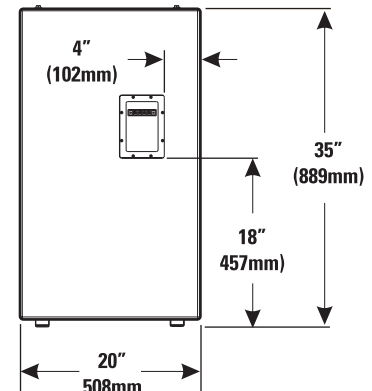

TD-000141-00 rev.D

© Derechos de autor 2003, 2004, QSC Audio Products, Inc.

QSC® es una marca comercial registrada de QSC Audio Products, Inc. "QSC" y el logotipo de QSC están registrados con la Oficina de Patentes y Marcas Comerciales de los Estados Unidos

Conexiones

Conexión normal

El altavoz LF-4215 tiene terminales de tornillo de barra protectora para su conexión. Los terminales aceptan cableado trenzado de hasta #10 AWG para altavoces. Use el alambre del calibre más grande y de la longitud más corta posible en cualquier instalación. Observe las marcas de polaridad y mantenga la polaridad uniforme en todo el sistema para obtener el mejor rendimiento.

Ejemplo de una conexión normal:

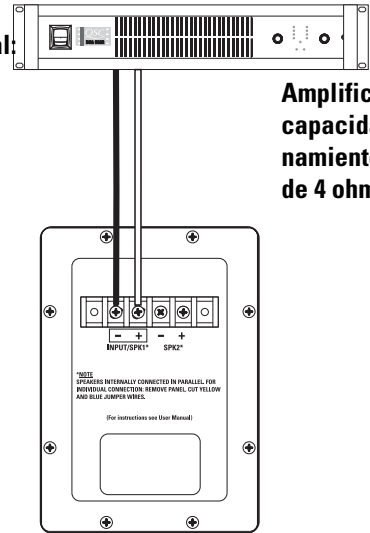

Amplificador con capacidad de accionamiento de cargas de 4 ohmios

Conexión en paralelo de un segundo SB-5218

Los terminales marcados SPK2 se pueden usar para conectar en paralelo otro altavoz LF-4215. Conecte los cables como se muestra en la ilustración, a la derecha. Nota: si el cableado interno de LF-4215 se ha modificado de alguna manera, es posible que no funcione. En este caso, quite la cúpula del terminal y verifique la presencia de alambres amarillos y azules de puentes instalados en fábrica; corrija el problema según se requiera, o solicite que den servicio al altavoz.

Ejemplo de conexión en paralelo:

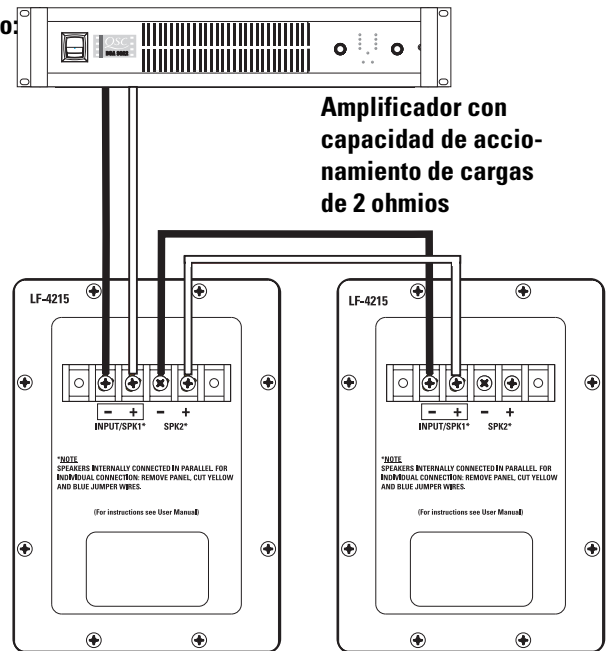

Amplificador con capacidad de accionamiento de cargas de 2 ohmios

Ejemplo de la conexión de un transductor individual:

Conexión del transductor individual (requiere modificación)

Los transductores están conectados en paralelo dentro de la caja. Si se requiere la conexión del transductor individual, quite la cúpula del terminal y quite los alambres amarillo y azul del puente que están conectados entre los terminales SPK1 y SPK2. Vuelva a colocar la cúpula del terminal y marque la caja con una nota que indique la modificación.



¡PRECAUCIÓN!
Requiere desmontar la cúpula del terminal y cortar los alambres amarillo y azul que conectan los terminales SPK1 y SPK2

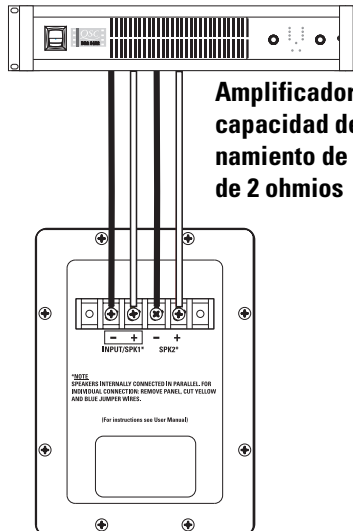

Amplificador con capacidad de accionamiento de cargas de 2 ohmios

Especificaciones del sistema LF-4215 (sujetas a cambio sin previo aviso)

Intervalo de frecuencias:	38 - 1300 Hertzios (± 3 dB) Intervalo utilizable de 30 - 1400 Hertzios (-10 dB)
Cobertura nominal:	100° horizontal X 55° vertical a 600 Hertzios
Salida máxima:	Pico calculado de SPL: 134.5 dB, 1 metro, medio espacio, a una potencia rms nominal con entrada de ruido rosa con factor de cresta de 6 dB, 25 - 250 Hertzios. Máximo calculado continuo de SPL: 128.5 dBA, 1 metro. La escala de dBA típicamente se usa para identificar fuentes de sonido que pueden causar pérdida auditiva permanente.
Impedancia:	4 ohmios, nominal 3.4 ohmios mínimo, 150 Hertzios 25 ohmios máximo, 22 Hertzios
Potencia máxima de entrada:	800 vatios rms (100 horas de ruido rosa con factor de cresta de 6 dB, 30 - 500 Hertzios) 1000 vatios rms (2 horas de ruido rosa con factor de cresta de 6 dB, 30 - 500 Hertzios, método AES) Capacidad recomendada de potencia del amplificador: 1600 vatios rms como máximo en 4 ohmios (por LF-4218)
Sensibilidad:	99.5 dB medio espacio, 93.5 dB espacio completo, 35 - 1000 Hertzios, 1 vatio, 1 metro
Procesamiento recomendado:	Filtro subsónico menor de 30 Hertzios, >18 dB por octava, la frecuencia máxima de cruce recomendada es de 1000 Hertzios. Las configuraciones DSP de QSC están disponibles en www.qscaudio.com . Los parámetros para el herraje de procesamiento alternativo están disponibles si así se solicitan.
Conectores:	Los terminales de tornillo de barra protectora aceptan alambre trenzado de hasta #10 AWG . Cuatro terminales: (dos de ENTRADA y dos de SALIDA PARALELA). Los excitadores están cableados internamente en paralelo. Para la conexión de un transductor independiente, quite los alambres azul y amarillo de los puentes que se encuentran en el lado interno de la cúpula del terminal y marque la caja de acuerdo con esto.
Transductores:	Dos transductores de baja frecuencia de alta eficiencia, de 15" (381 mm), con bobinas de voz de cobre de 4" (100 mm) ventiladas, en soportes de Kapton®. Diseño de alta excursión/baja deformación, con un manejo de potencia extremadamente alta, y baja compresión térmica y de puerto.
Caja:	Alineación Quasi B4, caja con puertos totalmente abocinados, diseño de puerto simétrico de baja turbulencia, afinado a 36 Hertzios, construido de cartón duro de media densidad y fuertemente soportado. Tiene pernos de montaje del woofer resistentes al vandalismo.
Tamaño:	30" de ancho X 35" de alto X 20" de profundidad (762 mm X 889 mm X 508 mm)
Peso:	195 libras envío, 172 libras neto (88/78 kg.)

SPL e impedancia en función de la frecuencia

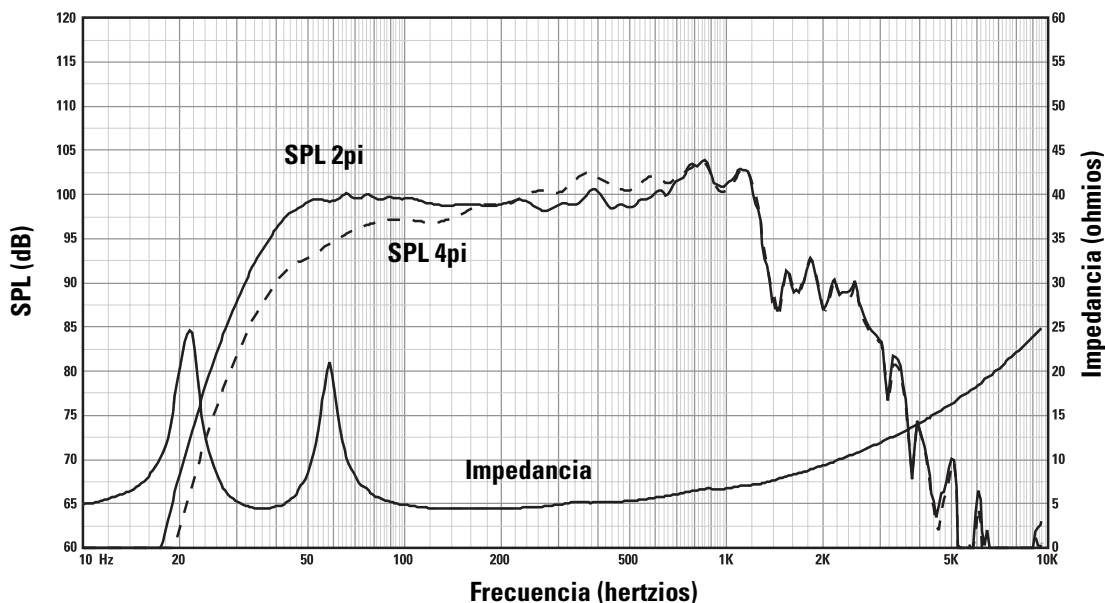

Garantía (sólo para EE.UU.; para otros países, consulte con su vendedor o distribuidor)

Renuncia de responsabilidad

QSC Audio Products, Inc. no es responsable por ningún daño a los amplificadores, ni a ningún otro equipo que sea causado por negligencia o instalación y/o uso inadecuado de este altavoz.

Garantía limitada de 3 años de QSC Audio Products

QSC Audio Products, Inc. ("QSC") garantiza que sus productos estarán libres de materiales y/o mano de obra defectuosos por un periodo de tres (3) años a partir de la fecha de la venta, y reemplazará las piezas defectuosas y reparará los productos que funcionen mal bajo esta garantía cuando el defecto ocurra bajo condiciones normales de instalación y uso, siempre y cuando la unidad se devuelva a nuestra fábrica o a una de nuestras estaciones autorizadas de servicio mediante transportación prepagada con una copia del comprobante de compra (por ejemplo, el recibo de la compra). Esta garantía requiere que el examen del producto devuelto indique, en nuestra opinión, un defecto de fabricación. Esta garantía no se extiende a ningún producto que hubiera estado sometido a uso indebido, negligencia, accidente, instalación incorrecta, o en el que se hubiera quitado o modificado el código de la fecha. QSC tampoco será responsable por daños incidentales y/o emergentes. Esta garantía le otorga derechos legales específicos. Esta garantía limitada es libremente transferible durante el período de la misma.

El cliente podría gozar de derechos adicionales, que podrían variar de un estado a otro.

En caso de que este producto fuera fabricado para exportación y venta fuera de los Estados Unidos o sus territorios, entonces no será aplicable esta garantía limitada. La eliminación del número de serie en este producto, o la compra de este producto de un distribuidor no autorizado, anularán esta garantía limitada. Esta garantía se actualiza periódicamente. Para obtener la versión más reciente de la declaración de la garantía de QSC, por favor visite www.qscaudio.com. Comuníquese con nosotros al 800-854-4079 o visite nuestro sitio en Internet en www.qscaudio.com.

Cómo comunicarse con QSC Audio Products

Dirección postal: QSC Audio Products, Inc.
1675 MacArthur Boulevard
Costa Mesa, CA 92626-1468 EE.UU.

Números de teléfono:

Número principal +1 (714) 754-6175

Ventas y comercialización +1 (714) 957-7100 o gratis (sólo EE.UU.) +1 (800) 854-4079

Servicio al cliente +1 (714) 957-7150 o gratis (sólo EE.UU.) +1 (800) 772-2834

Números de fax:

Fax de ventas y comercialización +1 (714) 754-6174

Fax de servicio al cliente +1 (714) 754-6173

World Wide Web: www.qscaudio.com

Correo electrónico: info@qscaudio.com

service@qscaudio.com



QSC Audio Products, Inc. 1675 MacArthur Boulevard Costa Mesa, California 92626 EE.UU.

©2003, 2004, "QSC" y el logo QSC están registrados con la Oficina de Patentes y Marcas Comerciales de EE.UU.

Kapton® es una marca comercial registrada de E.I. du Pont de Nemours and Company.



1675 MacArthur Blvd., Costa Mesa, CA 92626

Téléphone (standard) +1 (714) 754-6175 Ventes et Marketing +1 (714) 957-7100

ou +1 (800) 854-4079 (numéro vert valable aux États-Unis seulement)

Service clientèle +1 (714) 957-7150 ou numéro vert (États-Unis seulement) +1 (800) 772-2834

Manuel d'utilisation de systèmes de haut-parleurs de cinéma

Haut-parleur basse fréquence LF-4215

Introduction

L'enceinte basse fréquence double de 381 mm LF-4215 a été tout spécialement conçue pour les applications en salle de cinéma. Les exigences des cinémas en matière de réponse longue durée basse fréquence différencient le LF-4215 des systèmes de haut-parleurs de graves « rock-and-roll » plus conventionnels. Le LF-4215 couvre la plage de fréquence de 35 à 1 000 Hz, selon les exigences de haute fréquence du système. Les haut-parleurs de graves attenants (CCW) améliorent le couplage et permettent des angles de couverture larges sur une plus grande plage de fréquences que les modèles plus espacés.

Les deux transducteurs personnalisés de 38 cm et 400 W ont été spécialement développés pour un usage en salles de cinéma. Ils ont des bobines mobiles extrêmement larges (100 mm) et un pôle à événements multiples, gage d'absence de surchauffe, même à haute puissance. Les températures inférieures augmentent la durée de vie des transducteurs et diminuent le problème de compression de puissance à haute puissance. Un pôle évidé garantit le fonctionnement des bobines mobiles dans un espace magnétique symétrique (SMG), ce qui réduit la distorsion harmonique secondaire.

L'enceinte est constituée de panneaux en MDF de haute qualité et a des compartiments simples pour haut-parleurs de graves (SWC, un compartiment par transducteur). Dans l'éventualité rare d'une panne de transducteur, cette configuration empêche le dépassement de course du transducteur restant, qui serait causée par le chargement inadéquat du boîtier.

Les grands ports entièrement arrondis (FRP) garantissent la circulation d'air uniforme à travers les ports, surtout à haute puissance. Ceci empêche les interférences sonores. Les ouvertures internes et externes des ports sont entièrement arrondies.

Grâce au chargement symétrique des ports (SPL), les ports à basses sont équidistants de part et d'autre des transducteurs, ce qui répartit uniformément la pression interne à travers la surface arrière du transducteur. Ceci empêche le déplacement du cône d'un côté ou de l'autre par des forces déséquilibrées, ce qui réduit le risque d'excentrage de la bobine mobile à haute puissance.

Trois écrous en T sur le dessus de l'enceinte facilitent la fixation du système haute fréquence HF-75 ou du système sonore de hauteur moyenne MH-175 de QSC.



L'enceinte n'a pas été conçue pour être suspendue, balancée ou montée. La suspension, le balancement ou le montage de l'enceinte sont interdits.

Ce produit est capable de produire des niveaux de pression sonore susceptibles d'endommager l'ouïe de manière irréversible. Toujours maintenir les niveaux de pression sonore dans la zone d'écoute en deçà de niveaux susceptibles de compromettre l'ouïe.

Installer conformément aux instructions de QSC Audio Products et d'un technicien professionnel diplômé. Utiliser uniquement des fixations, supports, accessoires ou équerres spécifiés par QSC Audio Products. Confier toutes les réparations à un personnel qualifié. Une réparation ou maintenance est requise lorsque l'appareil a été endommagé d'une manière quelconque.



AVERTISSEMENT ! Avant de placer, installer, monter ou suspendre un haut-parleur, inspecter l'état de toute la visserie, du matériel de suspension, des armoires, des transducteurs, des supports et du matériel associé. Tout composant manquant, corrodé, déformé ou non adapté à la charge risque de réduire sensiblement la solidité de l'installation, sa mise en place ou sa portée. Une telle condition réduit sensiblement la sécurité de l'installation et doit être immédiatement corrigée. Utiliser uniquement du matériel de montage prévu pour les conditions de charge de l'installation et toute surcharge éventuelle à court terme imprévue. Ne jamais dépasser les spécifications nominales du matériel de montage ou de l'équipement. Consulter un technicien professionnel diplômé en cas de doute ou de question concernant l'installation physique de l'équipement.

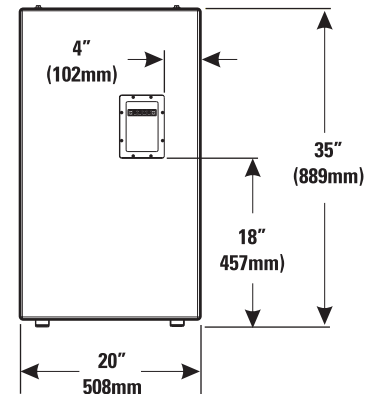
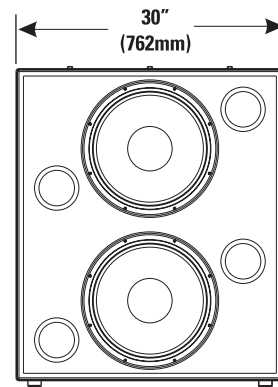
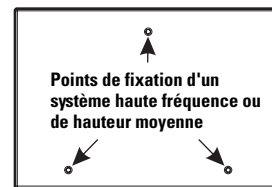
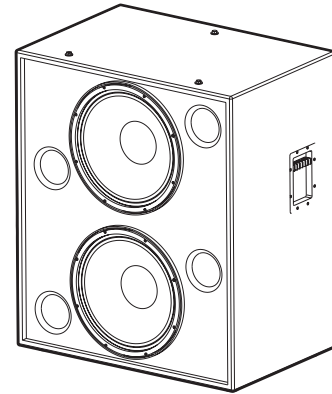

TD-000141-00 rév.D

© Copyright 2003, 2004, QSC Audio Products, Inc.

QSC® est une marque déposée de QSC Audio Products, Inc.

QSC et le logo QSC sont des marques déposées auprès de l'U.S. Patent and Trademark Office.

Branchements

Branchement normal

Le branchement du LF-4215 se fait à partir de bornes vissables de bornier à cloisons. Les bornes acceptent des câbles de haut-parleurs toronnés pouvant atteindre #10 AWG. Utiliser le calibre de conducteur maximal et la longueur de conducteur minimale, dans la mesure du possible, pour toute installation. Observer les repères de polarité et maintenir une polarité constante à travers le système pour une meilleure performance.

Branchement en parallèle d'un second LF-4215

Le marqueur de bornes SPK2 peut servir au branchement d'un autre LF-4215 en parallèle. Brancher les conducteurs comme indiqué sur l'illustration, à droite. Remarque : Si le câblage interne du LF-4215 a été modifié d'une manière quelconque, il est possible que ce branchement ne donne aucun résultat. Dans ce cas, retirer la cupule de la borne et vérifier la présence des connexions temporaires jaune et bleue ; corriger le problème ou faire réparer le haut-parleur.

Branchement individuel des transducteurs (modification obligatoire)

Les transducteurs sont câblés en parallèle à l'intérieur de l'enceinte. Si un branchement individuel est requis, retirer la cupule de la borne et retirer les connexions temporaires jaune et bleue entre les bornes SPK1 et SPK2. Remettre la cupule sur la borne et apposer sur l'enceinte une note indiquant la modification.

Exemple de branchement normal :

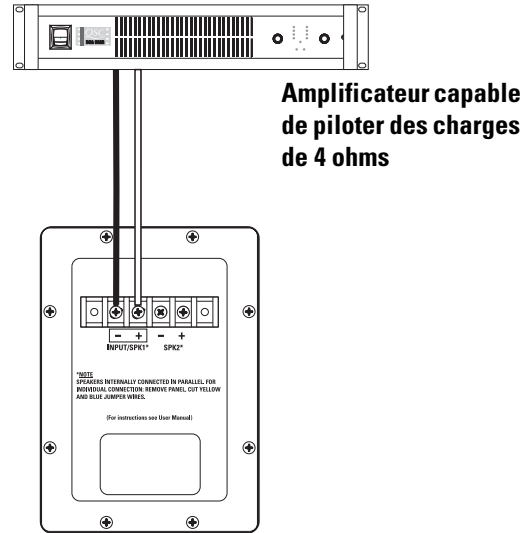

Exemple de branchement en parallèle :

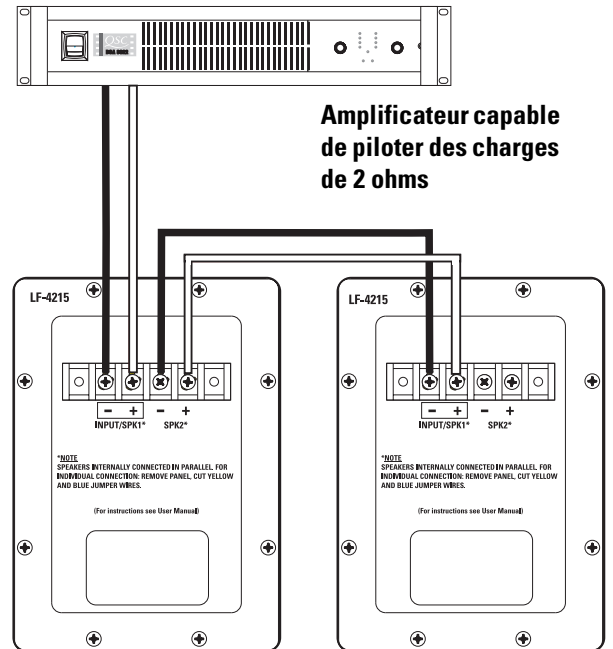

Transducteur individuel Exemple de branchement :

ATTENTION !
Exige le retrait de la cupule sur la borne et la coupe des connexions temporaires jaune et bleu entre les bornes SPK1 et SPK2.

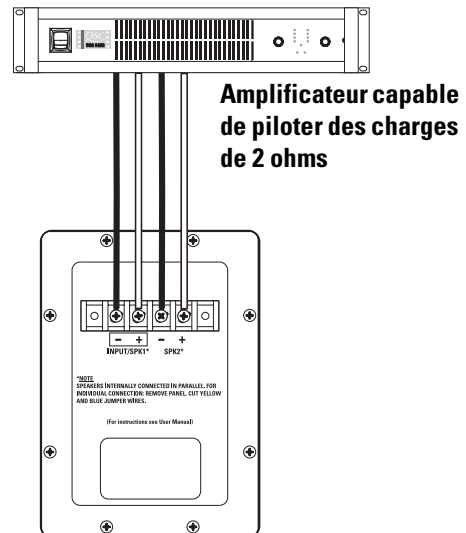

Caractéristiques techniques du LF-4215 (sujettes à modification sans préavis)

Plage de fréquence :	38 à 1 300 Hz (± 3 dB) 30 à 1 400 Hz (plage utile) (-10 dB)
Couverture nominale :	100° horizontal x 55° vertical à 600 Hz
Sortie maximale :	Niveau de pression sonore maximal calculé de 134,5 dB, à 1 m, demi-espacement, à la puissance nominale efficace avec 6 dB entrée de bruit rose de facteur de crête, 25 à 250 Hz. Niveau de pression sonore maximal calculé continu de 128,5 dBA, à 1 m. L'échelle de dBA sert généralement à identifier les sources sonores susceptibles de causer une surdité permanente.
Impédance :	4 ohms, nominale 3,4 ohms minimale, 150 Hz 25 ohms maximale, 22 Hz
Puissance d'entrée maximale :	800 W (efficace) (100 heures de bruit rose de facteur de crête 6 dB, 30 à 500 Hz) 1 000 W (efficace) (2 heures de bruit rose de facteur de crête 6 dB, 30 à 500 Hz, méthode AES) Capacité de puissance d'amplificateur recommandée - 1 600 W (efficace) maximum dans 4 ohms (conformément au modèle LF-4218)
Sensibilité :	99,5 dB demi-espacement, 93.5 dB espacement total, 35 à 1 000 Hz, 1 W, 1 m
Traitement recommandé :	Filtre subsonique inférieur à 30 Hz, >18 dB par octave ; fréquence de filtre passif maximale recommandée : 1 000 Hz. Les configurations des processeurs de champs sonores numériques QSC sont disponibles sur le site www.qscaudio.com . Les paramètres concernant d'autres matériels de traitement sont disponibles sur demande.
Connecteurs :	Les bornes acceptent des câbles de haut-parleurs toronnés pouvant atteindre #10 AWG. Quatre bornes : (deux d'entrée et deux de sortie parallèle). Les étages d'attaque sont câblés à l'intérieur en parallèle. Pour le branchement indépendant d'un transducteur, retirer la connexion temporaire bleue et la connexion temporaire jaune de l'intérieur de la cupule de borne et laisser une note sur l'enceinte signalant cette modification.
Transducteurs :	Deux transducteurs basse fréquence ultra-efficaces de 381 mm avec bobines mobiles en cuivre de 100 mm à événements sur formes Kapton®. Conception du type excursion élevée/faible distorsion, qui permet le traitement d'une puissance extrêmement élevée, et réduit la chauffe et la compression des ports.
Enceinte :	Enceinte résonnante à alignement quasi B4 avec ports entièrement arrondis ; conception symétrique des ports à faible turbulence ; réglée à 36 Hz, en panneaux de fibres de densité moyenne et fortement renforcé. Possède des boulons de fixation sur les haut-parleurs de graves résistants aux vandales.
Dimensions :	762 mm (largeur) x 889 mm (hauteur) x 508 mm (épaisseur)
Poids brut :	88 kg Poids net : 78 kg

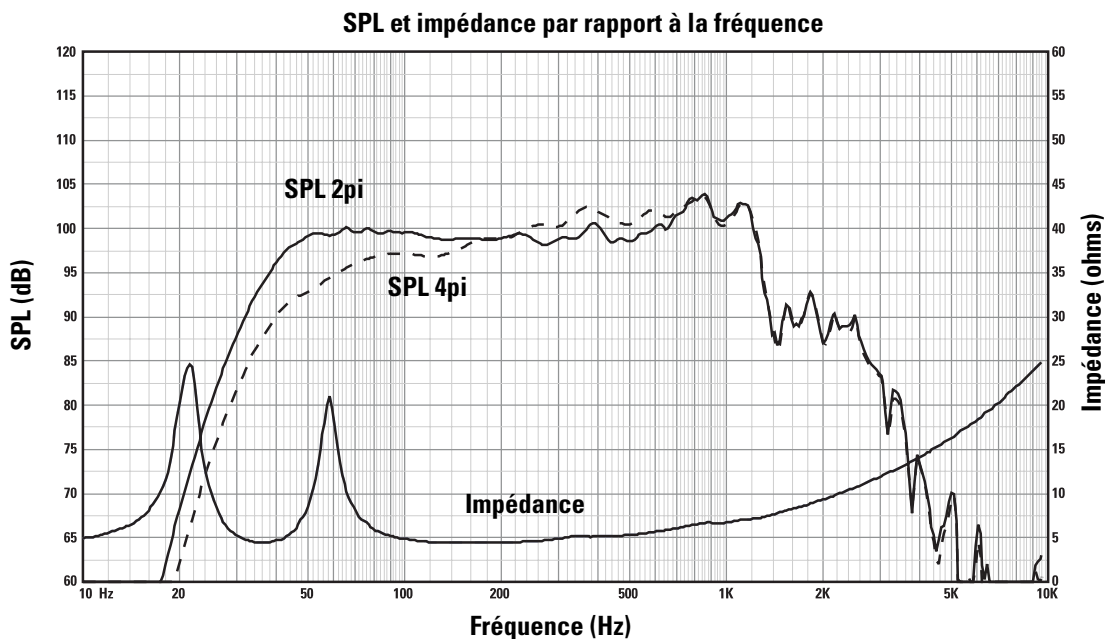

Garantie (États-Unis seulement ; dans les autres pays, consulter le revendeur ou le distributeur)

Avis de non-responsabilité

QSC Audio Products, Inc. n'est pas responsable des dommages subis par les amplificateurs ou tout autre équipement causé par un acte de négligence ou une installation impropre et/ou l'utilisation de ce haut-parleur.

QSC Audio Products - Garantie limitée de 3 ans

QSC Audio Products, Inc. (« QSC ») garantit que ses produits sont dépourvus de tout vice de fabrication et/ou de matériel pendant une période de trois (3) ans à partir de la date de vente et remplacera les pièces défectueuses et réparera les produits qui fonctionnent mal dans le cadre de cette garantie si le défaut survient dans des conditions normales d'installation et d'utilisation - à condition que l'appareil soit retourné à l'usine ou à l'un de nos centres de réparation agréés en port pré-payé, accompagné d'un justificatif d'achat (facture, par ex.). Cette garantie prévoit que l'examen du produit retourné doit indiquer, selon notre jugement, un défaut de fabrication. Cette garantie ne s'étend à aucun produit qui a été soumis à une utilisation abusive, un acte de négligence, un accident, une installation incorrecte ou un produit dont le code-date a été retiré ou effacé. QSC ne pourra être tenue pour responsable de dommages accessoires et/ou indirects. Cette garantie vous accorde des droits spécifiques. Cette garantie limitée est librement cessible durant sa période de validité.

Le client pourra bénéficier d'autres droits, variables d'une juridiction à l'autre.

Si ce produit a été fabriqué pour une exportation et une vente en dehors des États-Unis ou de ses territoires, cette garantie limitée ne s'appliquera pas. Le retrait du numéro de série sur ce produit ou l'achat de ce produit auprès d'un revendeur non agréé annulera cette garantie limitée. Cette garantie est régulièrement mise à jour. Pour obtenir la toute dernière version de la garantie de QSC, rendez-vous sur le site www.qscaudio.com. Contactez-nous au 800-854-4079 ou visitez notre site Web www.qscaudio.com.

Pour contacter QSC Audio Products

Adresse postale : QSC Audio Products, Inc.
1675 MacArthur Boulevard
Costa Mesa, CA 92626-1468, États-Unis

Téléphone :

Standard +1 (714) 754-6175

Ventes & Marketing +1 (714) 957-7100 ou numéro vert (États-Unis seulement) +1 (800) 854-4079

Service clientèle +1 (714) 957-7150 ou numéro vert (États-Unis seulement) +1 (800) 772-2834

Télécopieur :

Ventes & Marketing Télécopieur +1 (714) 754-6174

Service clientèle Télécopieur +1 (714) 754-6173

Site Web : www.qscaudio.com

E-mail : info@qscaudio.com

service@qscaudio.com





1675 MacArthur Blvd., Costa Mesa, CA, 92626 USA
Zentrale +1 (714) 754-6175 Verkauf und Marketing +1 (714) 957-7100
oder gebührenfrei (nur in den USA) +1 (800) 854-4079
Kundendienst +1 (714) 957-7150 oder gebührenfrei (nur in den USA) +1 (800) 772-2834

Kinolautsprecheranlagen - Benutzerhandbuch

Niederfrequenzlautsprecher LF-4215

Einführung

Das Gehäuse des LF-4215-Lautsprechers mit zwei 15-Zoll- (381-mm-) Niederfrequenzwandlern wurde speziell für Kinoanwendungen konstruiert. Da diese Anlage mit ihrem erweiterten Niederfrequenzgang die Voraussetzung für Kinoanwendungen erfüllt, unterscheidet sie sich von konventionellen „Rock-and-Roll“-Tiefenlautsprechern. Je nach den Anforderungen der Hochfrequenzanlage deckt das Modell LF-4215 den Frequenzbereich zwischen 35 und 1000 Hz ab. Durch die eng nebeneinander angeordneten, direktgekoppelten Tiefenlautsprecher (CCW - Close Coupled Woofers) werden im Vergleich zu Anordnungen mit größeren Abständen eine optimierte Kopplung und ein größerer Abstrahlwinkel bei größerem Frequenzbereich erzielt.

Die zwei 15-Zoll-Wandler mit 400 W wurden speziell für Kinoanwendungen entwickelt. Sie sind mit ungewöhnlich großen 4-Zoll- (100-mm-) Schwingspulen und, zur Gewährleistung kühler Betriebstemperaturen auch bei hohen Leistungspegeln, mit einem mehrfach belüfteten Polstück ausgestattet. Kühlere Temperaturen verlängern die Lebensdauer der Wandler und reduzieren das Problem der Leistungskomprimierung bei hoher Leistung. Durch das hinterschnittene Polstück wird die Schwingspule in einem symmetrischen Magnetluftspalt betrieben, was zu einer Reduzierung der sekundären harmonischen Verzerrung führt.

Das Gehäuse ist aus hochwertigen Pressspanplatten mittlerer Dichte gefertigt und weist einzelne Tiefenlautsprecherkammern (d. h. eine separate Kammer für jeden Wandler) auf. Im seltenen Fall eines Wandlerausfalls wird hierdurch eine übermäßige Auslenkung der restlichen Wandler aufgrund einer unsachgemäßen Belastung der Box verhindert.

Große Öffnungen mit Vollradius sorgen besonders bei hoher Leistung für eine gleichmäßige Luftströmung durch die Öffnungen. Auf diese Weise werden hörbare Luftgeräusche an der Öffnung vermieden. Sowohl die internen als auch die externen Öffnungen sind mit Vollradius versehen.

Die Bass-Öffnungen sind auf jeder Seite der Wandler in gleichmäßigem Abstand angeordnet. Diese symmetrische Belastung der Öffnungen (Symmetrical Port Loading - SPL) bewirkt einen besseren Ausgleich des Innendrucks an der Wandler-Rückseite. Dadurch wird eine seitliche Auslenkung der Membran durch asymmetrische Kräfte verhindert und eine mögliche Abweichung der Schwingspule aus ihrer Mittelstellung im Luftspalt bei hoher Leistung reduziert.

Die Montage der Hochfrequenz-Anlage HF-75 bzw. des oberen Mittenfrequenz-Systems MH-1075 von QSC wird durch drei T-Muttern oben im Gehäuse erleichtert.

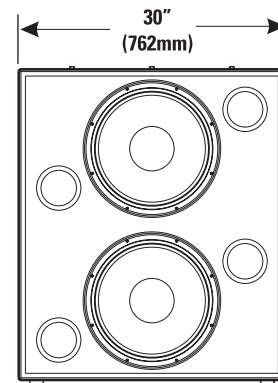
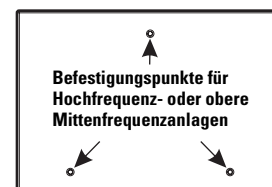
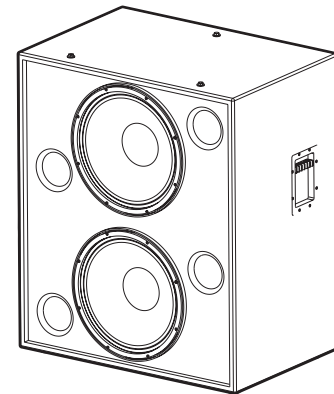

Das Gehäuse ist nicht für Hänge-, Flug- oder Abspannanwendungen vorgesehen. Dieses Gehäuse darf weder aufgehängt noch in Flug- oder Abspannanwendungen eingesetzt werden.

Dieses Produkt kann Schalldruckpegel erzeugen, die permanenten Gehörschaden verursachen können. Den Schalldruckpegel stets auf einen Pegel im Hörbereich einstellen, der keinen Gehörschaden verursacht.

Die Installation von einem lizenzierten Fachtechniker gemäß der Anleitung von QSC Audio Products vornehmen lassen. Nur von QSC Audio Products, Inc. spezifizierte Befestigungskomponenten, Montagezubehör oder Halterungen verwenden. Wartungsarbeiten nur von qualifiziertem Personal ausführen lassen. Wartungsmaßnahmen sind erforderlich, wenn das Produkt auf irgendeine Weise beschädigt wurde.



ACHTUNG! Inspizieren Sie vor dem Aufstellen, Installieren, Verdrahten oder Aufhängen von Lautsprecherprodukten alle Befestigungsteile, Aufhängungen, Gehäuse, Wandler, Halterungen und damit in Verbindung stehende Vorrichtungen auf eventuelle Schäden. Fehlende, korrodierte, verformte oder nicht belastbare Komponenten könnten die Stabilität der Installation, der Aufstellung oder der Gerätekombination deutlich reduzieren. Jeder Zustand dieser Art bewirkt eine erhebliche Verringerung der Sicherheit der Installation und sollte umgehend behoben werden. Verwenden Sie ausschließlich Befestigungsteile, die für die Belastungsbedingungen der Installation zugelassen und für jede potenzielle, unerwartete, kurzfristige Überlastung ausgelegt sind. Die Nennleistung der Befestigungsteile bzw. Ausrüstung darf keinesfalls überschritten werden. In Zweifelsfällen oder bei Fragen zur Installation eines Geräts sollten Sie einen qualifizierten Techniker hinzuziehen.

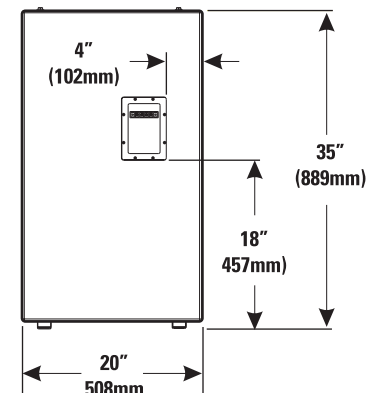

Verbindungen

Normaler Anschluss

Das Modell LF-4215 wird über Barrier-Strip-Schraubklemmen angeschlossen. Die Klemmen können Lautsprecher-Litzendraht bis zu einer Stärke von 10 AWG (5,2 mm²) aufnehmen. Bei der Installation stets den größtmöglichen Leiterquerschnitt und die kürzeste Leiterlänge verwenden. Die Polaritätsmarkierungen beachten und zur Erzielung optimaler Leistung auf eine gleich bleibende Polarität in der gesamten Anlage achten.

Paralleler Anschluss des zweiten SB-5218

Ein weiterer LF-4215 kann über die mit der Bezeichnung SPK2 gekennzeichnete Klemme parallel angeschlossen werden. Die Drähte wie in der rechten Abbildung dargestellt anschließen. Hinweis: Wenn die interne Verdrahtung des LF-4215 auf irgendeine Weise modifiziert wurde, ist dieser Anschluss möglicherweise nicht funktionsfähig. In diesem Fall muss die Klemmenbuchse entfernt und geprüft werden, ob der werkseitig installierte gelbe und blaue Überbrückungsdraht vorhanden sind. Nach Bedarf Abhilfe schaffen oder den Lautsprecher reparieren lassen.

Anschluss einzelner Wandler (Modifizierung erforderlich)

Die Wandler sind im Gehäuse parallel verdrahtet. Wenn die Wandler separat angeschlossen werden müssen, die Klemmenbuchse entfernen und den zwischen den Klemmen SPK1 und SPK2 angeschlossenen gelben und blauen Überbrückungsdraht entfernen. Die Klemmenbuchse wieder anbringen und die Modifikation auf dem Gehäuse notieren.

Beispiel eines normalen Anschlusses:

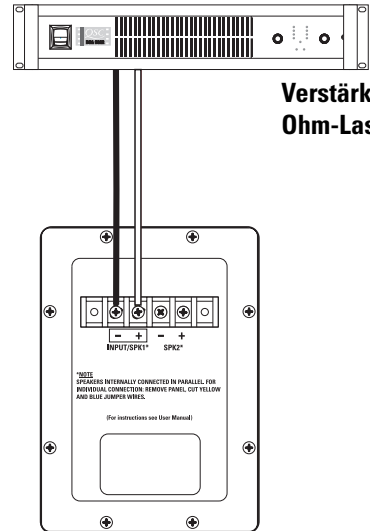

Beispiel eines parallelen Anschlusses:

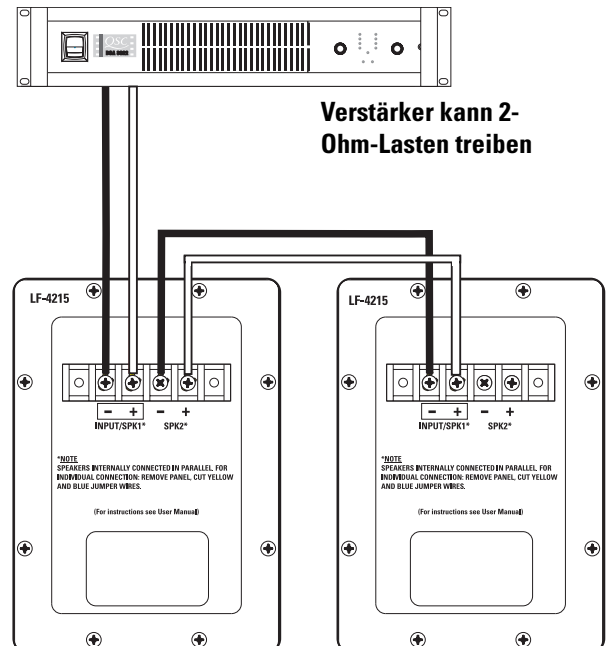

Einzelner Wandler, Anschlussbeispiel:



VORSICHT! Setzt den Ausbau der Klemmenbuchse und das Trennen des gelben und blauen Überbrückungsdrahts voraus, die die Klemmen SPK1 und SPK2 verbinden.

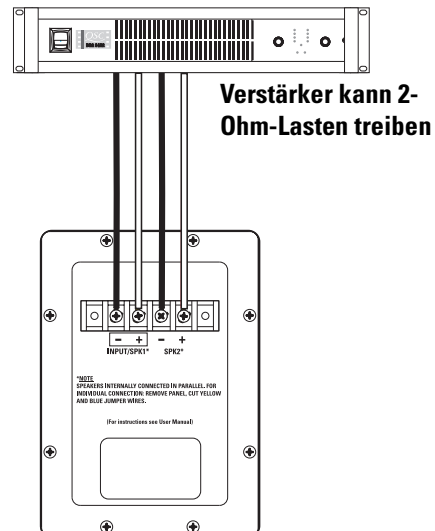

LF-4215 - Technische Daten (können jederzeit ohne vorherige Mitteilung geändert werden)

Frequenzbereich:	38 Hz - 1300 Hz (± 3 dB) Nutzbereich 30 - 1400 Hz (-10 dB)
Nominelle Abstrahlung:	100° horizontal x 55° vertikal bei 600 Hz
Maximaler Ausgang:	134,5 dB berechneter Spitzen-SPL, 1 m, Halbraum bei effektiver Nennleistung mit Rosa-Rauschen-Eingang-Crestfaktor von 6 dB, 25 - 250 Hz; 128,5 dBA berechneter kontinuierlicher Maximal-SPL, 1 m Schallquellen, die permanenten Gehörschaden verursachen können, werden in der Regel mithilfe der dBA-Skala identifiziert.
Impedanz:	4 Ohm (nominell) 3,4 Ohm min., 150 Hz 25 Ohm max., 22 Hz
Maximale Eingangsleistung:	800 W eff. (100 Stunden bei Rosa-Rauschen mit einem Crestfaktor von 6 dB, 30 - 500 Hz) 1000 W eff. (2 Stunden bei Rosa-Rauschen mit einem Crestfaktor von 6 dB, 30 - 500 Hz, AES-Methode) Empfohlene Verstärkerleistung: max. 1600 W eff. über 4 Ohm (je LF-4218)
Empfindlichkeit:	99,5 dB Halbraum, 93,5 dB Vollraum, 35 - 1000 Hz, 1 W, 1 m
Empfohlene Verarbeitung:	Untertonfrequenzfilter unter 30 Hz, >18 dB je Oktave, empfohlene maximale Crossover-Frequenz: 1000 Hz. QSC DSP-Konfigurationen können im Internet unter www.qscaudio.com eingesehen werden. Parameter für alternative Verarbeitungshardware sind auf Anfrage erhältlich.
Anschlüsse:	Barrier-Strip-Schraubklemmen für Litzen Draht-Querschnitt bis zu 10 AWG (5,2 mm ²). 4 Klemmen: 2 Eingangsklemmen (INPUT) und 2 parallele Ausgangsklemmen (PARALLEL OUT). Druckkammertreiber sind intern parallel verdrahtet. Für separate Wandleranschlüsse müssen der blaue und der gelbe Überbrückungsdraht an der Innenseite der Klemmenbuchse entfernt werden. Das Gehäuse entsprechend markieren.
Wandler:	Zwei 15-Zoll- (381-mm-) Hochleistungs-Niederfrequenzwandler mit belüfteten 4-Zoll- (100-mm-) Kupfer-Schwingspulen auf Kapton® Schablonen. Für hohe Auslenkung/geringe Verzerrung, äußerst hohe Belastbarkeit und geringe Wärmekomprimierung und Port Compression.
Gehäuse:	Quasi-B4-Ausrichtung, Vollradius-Öffnungen, geringe Luftgeräusche durch symmetrische Öffnungsanordnung, auf 36 Hz abgestimmt, aus Pressspanplatten mittlerer Dichte gefertigt und stabil verstrebt. Vandalismussichere Tieftonlautsprecher-Montagebolzen.
Größe:	762 mm breit x 889 mm hoch x 508 mm tief
Gewicht:	Versandgewicht 88 kg, Nettogewicht 78 kg

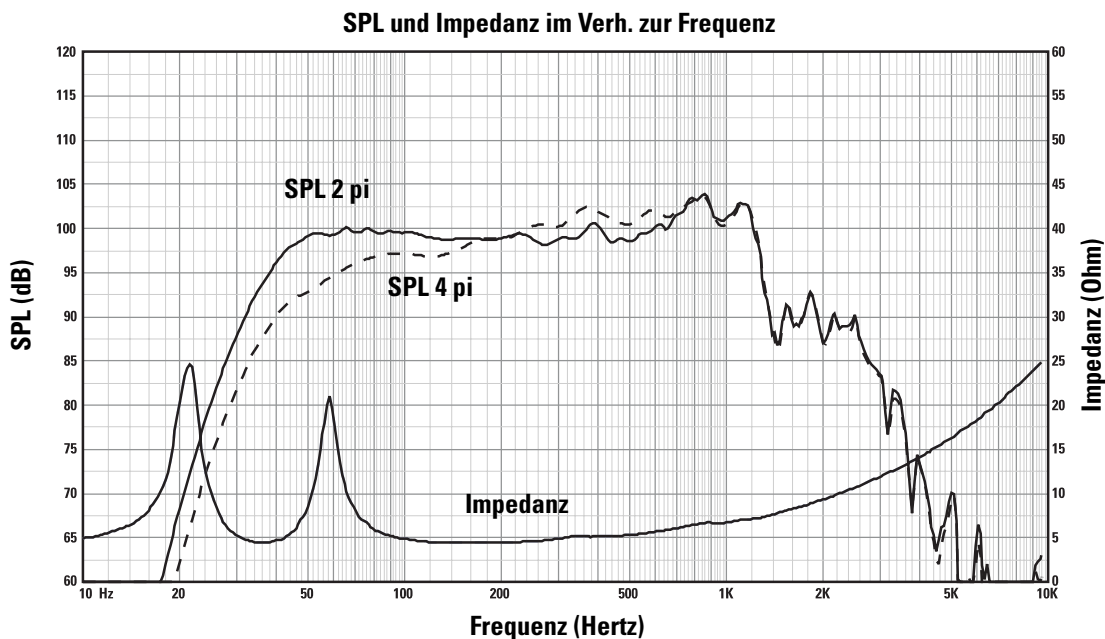

Garantie (nur für die USA; wenden Sie sich zwecks Garantieinformationen für andere Länder an Ihren Händler oder Distributor)

Haftungsausschluss

QSC Audio Products, Inc. ist nicht für Schäden an Verstärkern oder anderen Geräten haftbar, die durch Fahrlässigkeit oder eine unsachgemäße Installation und/oder Verwendung dieses Lautsprecherprodukts verursacht werden.

Beschränkte Dreijahresgarantie durch QSC Audio Products

QSC Audio Products, Inc. („QSC“) gewährleistet, dass seine Produkte für einen Zeitraum von drei (3) Jahren ab dem Kaufdatum keine Material- und/oder Ausführungsfehler aufweisen werden, und QSC verpflichtet sich zum Ersatz defekter Teile und zur Reparatur funktionsgestörter Produkte gemäß dieser Garantie, wenn dieser Fehler bei einer normalen Installation und unter normalen Gebrauchsbedingungen auftritt – vorausgesetzt, dass das Gerät unter Vorauszahlung der Transportkosten und zusammen mit einer Kopie des Kaufnachweises (z.B. der Kaufquittung) an unser Werk zurückgeschickt oder an eine unserer autorisierten Kundendienststellen eingeschickt wird. Diese Garantie setzt voraus, dass die Prüfung des zurückgeschickten Produkts in unserem Ermessen einen Herstellungsdefekt zu erkennen gibt. Diese Garantie erstreckt sich auf keine Produkte, die einer unsachgemäßen oder fahrlässigen Behandlung, Unfällen oder einer unvorschriftsmäßigen Installation unterlagen, oder deren Datumscode entfernt oder unkenntlich gemacht wurde. QSC ist für keine Neben- und/oder Folgeschäden haftbar. Diese Garantie gewährt Ihnen bestimmte Rechte. Diese beschränkte Garantie ist während der Garantiezeit frei übertragbar.

Manche Kunden können je nach Rechtsprechung zusätzliche und andere Rechte besitzen.

Falls dieses Produkt zum Export und Verkauf außerhalb der Vereinigten Staaten oder deren Hoheitsgebieten hergestellt wurde, besitzt diese eingeschränkte Garantie keine Gültigkeit. Die Entfernung der Seriennummer auf diesem Produkt oder der Kauf dieses Produkts von einem nicht autorisierten Händler macht diese beschränkte Garantie unwirksam. Diese Garantie wird gelegentlich aktualisiert. Die jeweils aktuellste Version der Garantieerklärung von QSC finden Sie im Internet unter www.qscaudio.com. Sie erreichen uns telefonisch unter +1 800-854-4079 (gebührenfrei in den USA und Kanada) oder im Internet unter www.qscaudio.com.

Kontaktaufnahme mit QSC Audio Products

Postanschrift: QSC Audio Products, Inc.
1675 MacArthur Boulevard
Costa Mesa, CA 92626-1468 USA

Telefonnummern:

Zentrale: +1 (714) 754-6175

Verkauf und Marketing +1 (714) 957-7100 oder gebührenfrei (nur in den USA) +1 (800) 854-4079

Kundendienst +1 (714) 957-7150 oder gebührenfrei (nur in den USA) +1 (800) 772-2834

Fax-Nummern:

Verkauf und Marketing (Fax) +1 (714) 754-6174

Kundendienst (Fax) +1 (714) 754-6173

Internet:www.qscaudio.com

E-Mail:info@qscaudio.com

service@qscaudio.com

QSC Audio Products, Inc. 1675 MacArthur Boulevard Costa Mesa, California 92626 USA
©2003, 2004, „QSC“ und das QSC-Logo sind beim US-Patent- und Markenamt angemeldet.
Kapton® ist eine eingetragene Marke von E.I. du Pont de Nemours and Company.

The logo for QSC Audio Products, featuring the letters 'QSC' in a bold, black, sans-serif font. The 'Q' and 'S' are connected, and the 'C' is slightly separated. A small trademark symbol (TM) is located to the upper right of the 'C'.



1675 MacArthur Blvd., Costa Mesa, CA 92626

主要号码 (714) 754-6175 销售和部门 (714) 957-7100 或免费电话 (仅限美国)
(800) 854-4079 客服 (714) 957-7150 或免费电话 (仅限美国) (800) 772-2834

影院扬声器系统用户手册

LF-4215 低频扬声器

简介

LF-4215 双 15" (381 毫米) 的低频机壳专为影院应用设计。LF-4215 和传统“摇滚”低音系统的不同之处在于它可以满足影院对扩展低频响应的要求。根据高频系统的要求, LF-4215 可覆盖 35 赫兹到 1000 赫兹的频率范围。由于强耦合低音扬声器 (CCW) 的低音扬声器之间间距小, 因此和大间距设计相比, 具有耦合好, 较大频率范围覆盖角度宽的特点。

两个定制 400 瓦, 15" 变频器专为影院使用开发。特别具有超大 4" (100 毫米) 音圈和一个多通风板片, 确保即使在高功率的情况下, 也能保持清凉的运行环境。温度低可以增加变频器的寿命, 并且减少高功率下的功率压缩问题。低切极片确保音圈在对称磁隙 (SMG) 中运行, 从而减少了二次谐波失真。

机壳由高质量的总配线架面板构成, 具有单低音室的特点 (SWC, 每个变频器有各自分开的音室)。在非常罕见的情况下如果变频器出现故障, 可以防止不当盒负荷造成的其余变频器振幅过大。

大型、全辐射口 (FRP) 确保气流平稳通过端口, 特别是在功率较高的情况下。这可以防止潜在的声音端口噪音紊乱。无论是内部还是外部端口开口都是全辐射的。

由于具有端口负荷 (SPL), 低音端口均匀地分布在变频器两侧, 使通过变频器背表面的内部压力更加一致。这样就防止了圆锥由于力量失衡而被错误地放置在一边或另一边, 从而减少了高功率情况下将音圈赶出空隙中心的情况。

机罩上部的 3 个 T 形螺母使得安装 QSC 的 HF-75 高频系统或 MH-1075 中高频系统更加容易。

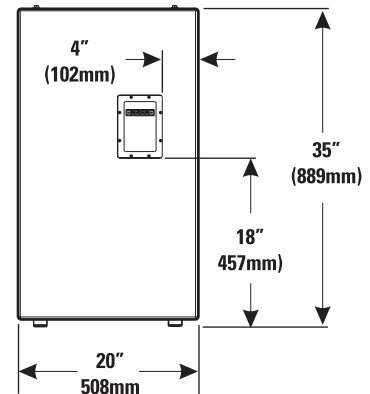
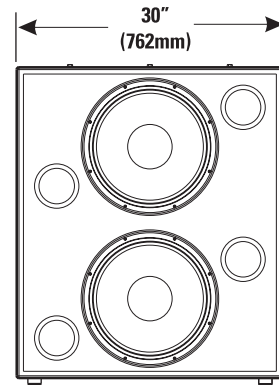
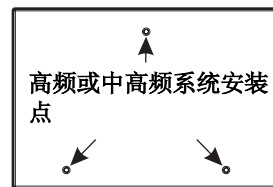
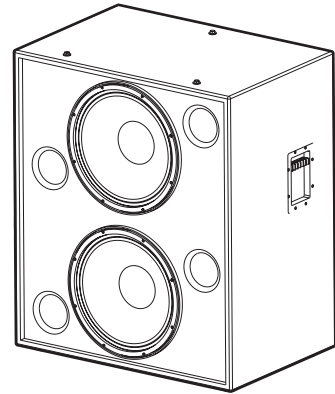

机罩并没有设计成悬挂式、可操纵式、或装配式。请勿对此机罩进行悬挂、操纵或装配。

此产品可产生对人类听觉造成永久损伤的声压强度。请将听音区域内的声压强度总是保持在不会对人的听力造成损伤的水平。

按照 QSC Audio Product 的说明并在授权的专业工程师的指导下安装。仅限使用 QSC Audio Product 公司规定的附件、底座、零件或支架。所有维护请由合格的专业人士进行。设备如果受到损坏, 就需要进行维修。



警告! 放置、安装、装配或悬挂扬声器产品时, 检查所有硬件、悬架、搁柜、变频器、支架和相关设备有无损坏。任何额定部件的缺失、腐蚀、变形或未装载都可能大大降低安装、放置或排列的强度。出现任何严重降低安装安全度的情况应立即更正。仅限使用额定安装的硬件及任何可能的短期突发超载。切勿超过硬件或设备的额定标准。如有任何关于物理设备安装的疑问或问题, 请咨询获得许可的专业工程师。

连接

正常连接

LF-4215 具有用于连接的阻挡带螺旋式终端。此终端接受高达 #10AWG 的绞合式扬声器电线。对于特定的安装，尽可能使用最大电线尺寸和最短电线长度。观察极性标志，确保整个系统极性一致，以便获得最佳表现。

正常连接样例

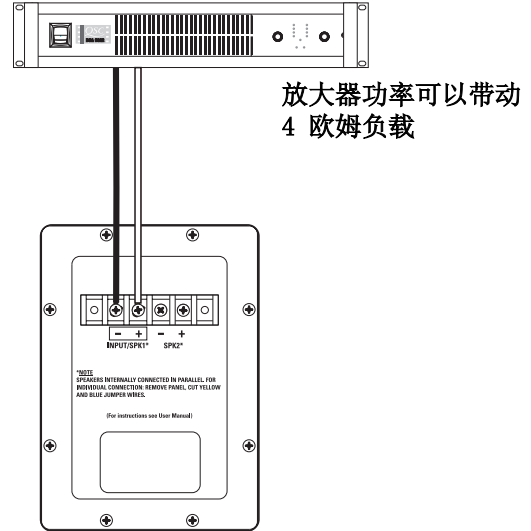

第二个 SB-5218 并联

终端标志 SPK2 可用于并联另一个 LF-4215。按照右图所示连接线路。注意：如果 LF-4215 的内部连线经过任何修改，便不会起作用。如果情况如此，拿掉终端杯，然后验证有无工厂黄色跳线电线和蓝色跳线电线；按要求修改或者对此扬声器进行维修。

并联样例

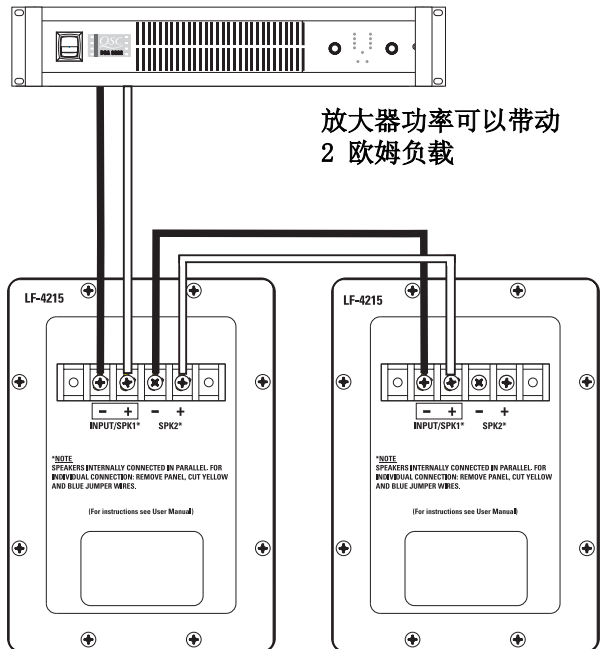

单个变频器连接（需要修改）

变频器在机罩内并行连线。如果要求单个变频器连接，拿掉终端杯，然后拿掉连接在 SPK1 和 SPK2 终端间的黄色和蓝色跳线电线。换掉终端杯，然后在机罩上作修改标记。

单个变频器连接样例

 **注意：必须拿掉终端杯，切断连接 SPK1 和 SPK2 终端的黄色和蓝色跳线电线**

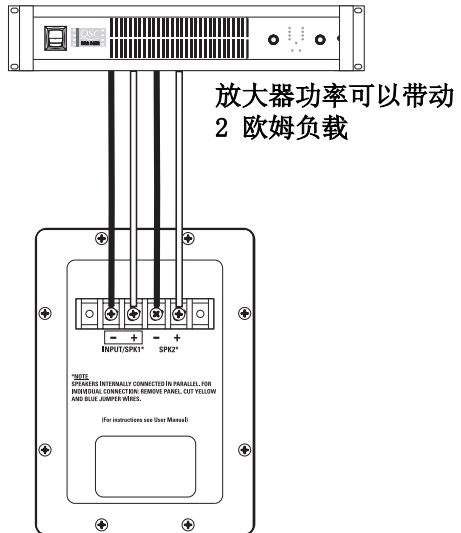

LF-4215 产品规格 (如有改变恕不另行通告)

频率范围:	38 - 1300 赫兹 (± 3 dB) 30 - 1400 赫兹可用范围 (-10 dB)
标称覆盖范围:	600 赫兹时 100° 水平 X 55° 垂直
最大输出:	134.5 dB SPL 计算峰值、1 米、半间距、在额定 rms 功率 6dB 振幅因子粉红噪声输入, 25 - 250 赫兹。 128.5 dBA SPL 计算最大连续, 1 米。通常使用 dBA 尺以确定会造成永久听力损失的声源。
阻抗:	标称 4 欧姆 最小 3.4 欧姆, 150 赫兹 最大 25 欧姆, 22 赫兹
最大输入功率:	800 瓦 rms (6dB 振幅因子粉红噪声的 100 小时, 30 - 500 赫兹) 1000 瓦 rms (6dB 振幅因子粉红噪声 2 小时, 30 - 500 赫兹, AES 方法) 推荐放大器功率 - 1600 瓦 rms 最大到 4 欧姆 (每 LF-4218)
灵敏度:	99.5 dB 半间距, 93.5 dB 全间距, 35 - 1000 赫兹, 1 瓦, 1 米
推荐处理:	次音速过滤低于 30 赫兹, 每八度音程大于 18 dB 最大推荐分频频率为 1000 赫兹。从 www.qscaudio.com 网站可获得 QSC DSP 的配置情况。如有要求即可获得替换处理硬件的参数。
连接器:	阻挡带螺旋式终端接受高达 #10 AWG 绞合式布线。四个终端 (两个输入和两个并行输出)。驱动器以并联形式内部连接。独立连接变频器的时候, 拿掉终端杯内部边上的蓝色跳线电线和黄色跳线电线, 然后相应标记机罩。
变频器:	两个 15" (381 毫米) 高效低频变频器通风式 4" (100 毫米) Kapton [®] 线圈架上的铜音圈。高偏移 / 低失真设计, 带超高功率处理, 以及低温和端口压缩。
机罩:	类似的 B4 对齐, 端口机罩带全喇叭形端口, 低紊流对称端口设计, 调整为 36 赫兹, 由中密度纤维板和重型支撑构成。具有防破坏低音喇叭安装螺丝的特点。
尺寸:	30" (宽) X 35" (高) X 20" (深) (762 mm X 889 mm X 508 mm)
重量:	195 磅 (运输), 172 磅 (净重) (88/78 公斤)

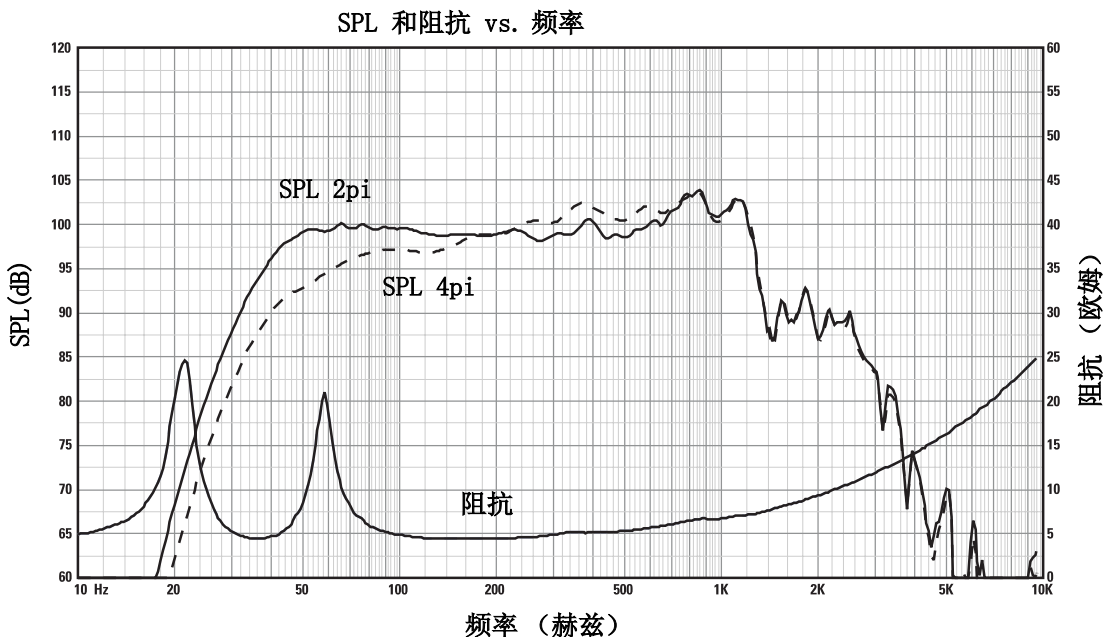

保修（仅限美国；其它国家，请联系您的经销商或分销商）

声明

QSC Audio Products, Inc. 不承担因疏忽、或不当安装和 / 或不当使用本放大器产品而对扬声器或任何其它设备造成损坏的任何责任。

QSC Audio Products 3 年有限质保协议。

QSC Audio Products, Inc. (QSC) 担保其产品自销售日起三年内不会发生材料或制造工艺缺陷，若在正常安装和使用条件下发生的损坏，QSC 将按照本质保协议更换有缺陷的零件和维修故障产品 - 但您要将本产品送回我们的工厂或任一授权维修点，预付运送费用并附带一份购买证明即销售收据影印本。此质保协议规定，退回的产品检查必须标明经我们判断的制造缺陷。本质保不适用于任何因误用、疏忽、意外事故、不正确地安装，或日期编码被去掉或破损的产品。QSC 不对意外和 / 或间接发生的损害承担责任。此质保赋予您特定的法律权力。此有限质保在保证期内可自由转让。

在不同的州，顾客可能会有额外的权利。

此质保协议不适用于为出口或不在美国销售而生产的产品。产品上缺少序列号，或者从非授权销售商处购买此产品，将失去此有限质保协议。此质保协议定期更新。请浏览：www.qscaudio.com，获得最新版本的 QSC 质保协议声明，联系我们：800-854-4079，或访问我们的网站：www.qscaudio.com。

联系 QSC Audio Products

通信地址 :QSC Audio Products, Inc.
1675 MacArthur Boulevard
Costa Mesa, California 92626-1468 USA

电话:

主要号码 (714) 754-6175

销售和市场部门 (714) 957-7100 或免费电话 (仅限美国) (800) 854-4079

客服 (714) 957-7150 或免费电话 (仅限美国) (800) 772-2834

传真:

销售与市场部门传真 (714) 754-6174

客服传真 (714) 754-6173

网址 www.qscaudio.com

E-mail:info@qscaudio.com

service@qscaudio.com



QSC Audio Products, Inc. 1675 MacArthur Boulevard Costa Mesa, California 92626 USA

©2003, 2004, “QSC” 以及 QSC 的标志在美国专利和商标局注册。

Kapton® 为 E. I. du Pont de Nemours and Company 的注册商标。