

FILM-TECH

THE INFORMATION CONTAINED IN THIS ADOBE ACROBAT PDF FILE IS PROVIDED AT YOUR OWN RISK AND GOOD JUDGMENT.

THESE MANUALS ARE DESIGNED TO FACILITATE THE EXCHANGE OF INFORMATION RELATED TO CINEMA PROJECTION AND FILM HANDLING, WITH NO WARRANTIES NOR OBLIGATIONS FROM THE AUTHORS, FOR QUALIFIED FIELD SERVICE ENGINEERS.

IF YOU ARE NOT A QUALIFIED TECHNICIAN, PLEASE MAKE NO ADJUSTMENTS TO ANYTHING YOU MAY READ ABOUT IN THESE ADOBE MANUAL DOWNLOADS.

WWW.FILM-TECH.COM

**Bell & Howell Autoload® Filmosound®
16mm Sound Projectors—Models 2585, 2590, 2592**

Owners and Operators Guide

IMPORTANT:

Please read these instructions carefully
before operating this projector.

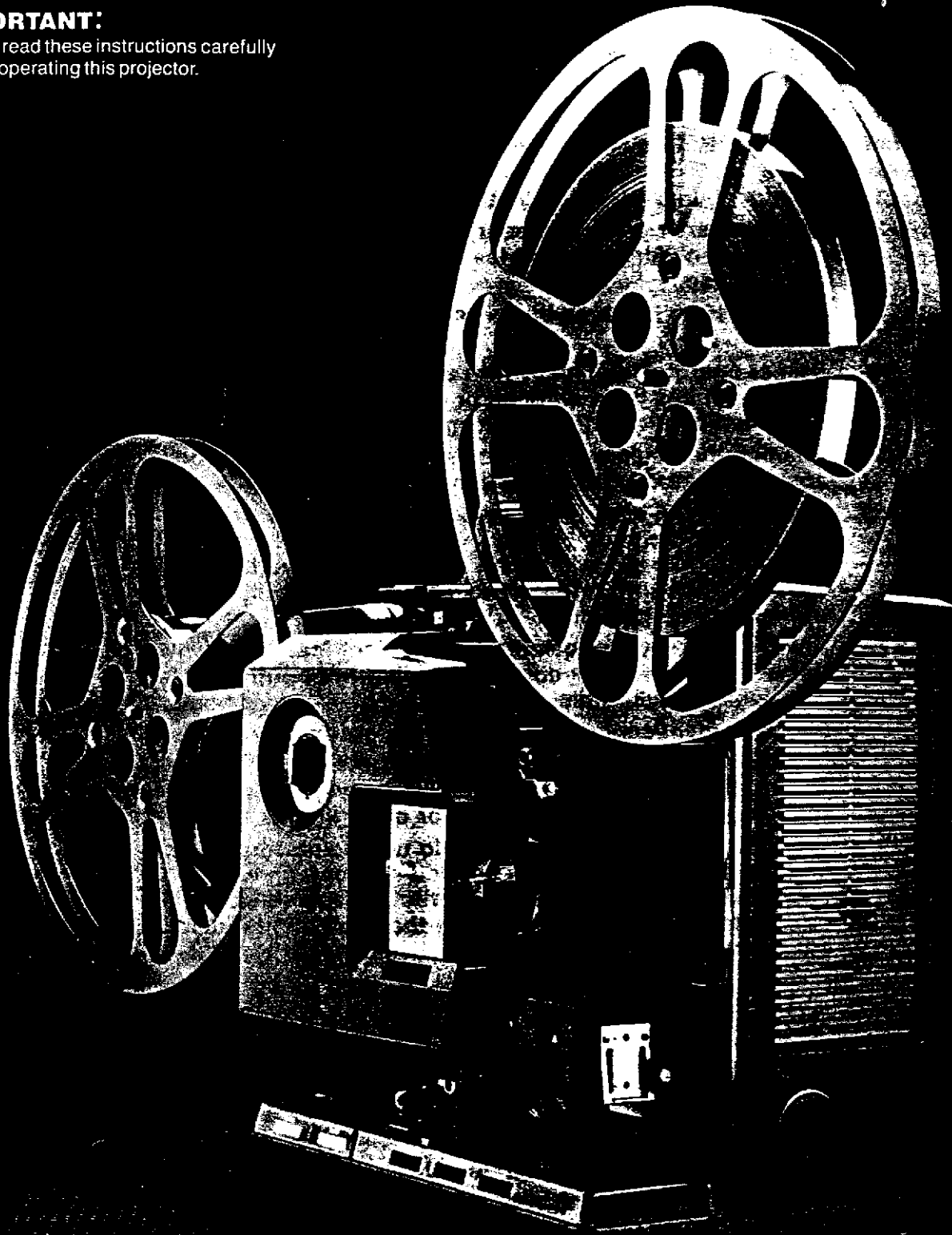

Visual Communications Group
Audio Visual Products

**Bell & Howell Autoload® Filmosound®
16mm Sound Projectors—Models 2585, 2590, 2592**

Owners and Operators Guide

IMPORTANT:

Please read these instructions carefully
before operating this projector.

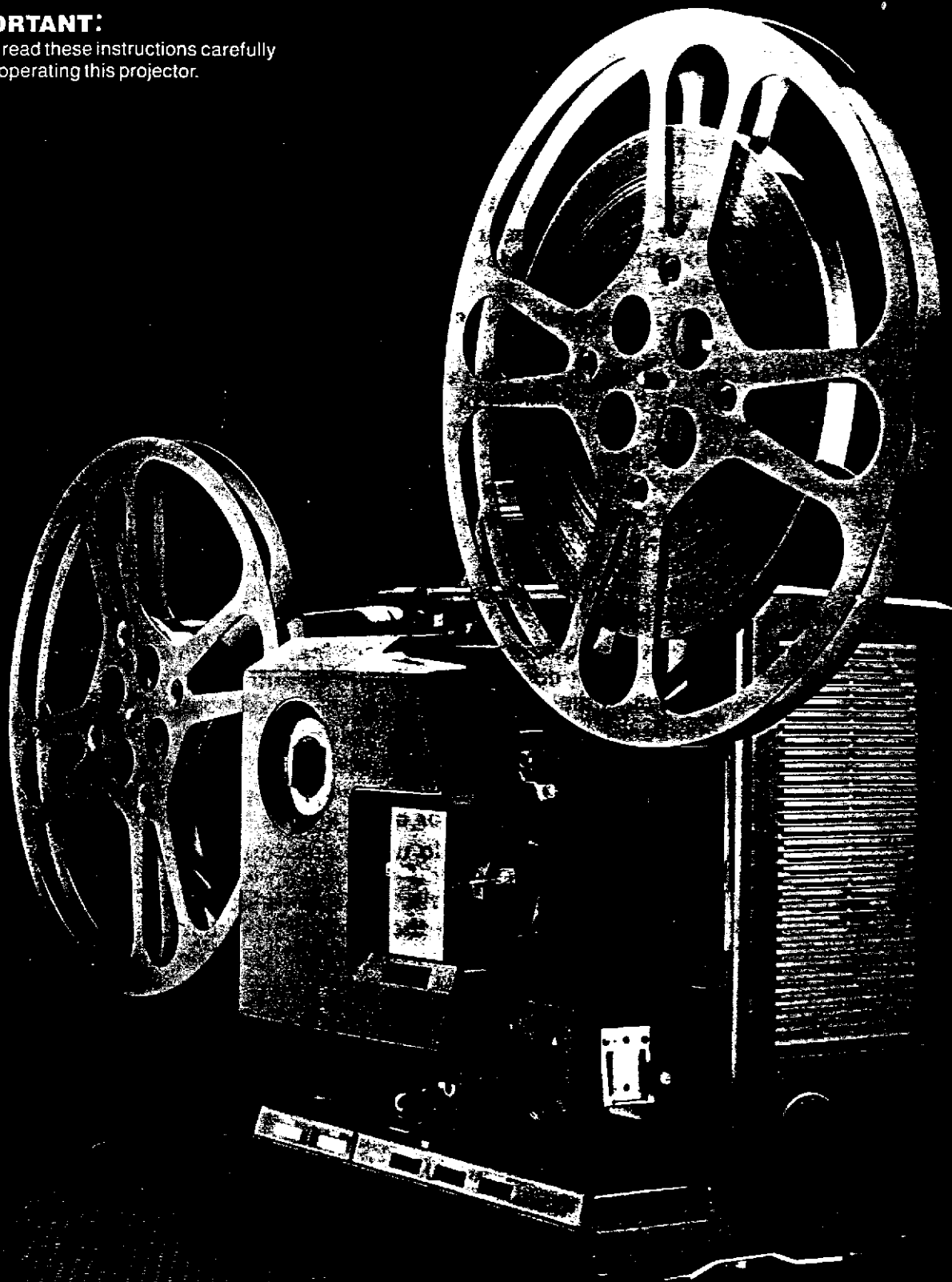

Visual Communications Group
Audio Visual Products

IMPORTANT SAFEGUARDS— SAVE THESE INSTRUCTIONS

When using your photographic equipment, basic safety precautions should always be followed, including the following:

1. Read and understand all instructions.
2. Close supervision is necessary when any equipment is used by or near children. Do not leave equipment unattended while in use.
3. Care must be taken as burns can occur from touching hot parts.
4. Do not operate equipment with a damaged cord or if the equipment has been dropped or damaged—until it has been examined by a qualified serviceman.
5. Position the equipment in such a way so as not to block any air intake or exhaust openings.
6. If an extension cord is necessary, a cord with a suitable current rating should be used. Cords rated for less amperage than the equipment requires may overheat. Care should be taken to arrange the cord so that it will not be tripped over or pulled.
7. Always unplug your equipment from electrical outlet when not in use. Never yank cord to pull plug from outlet. Grasp the plug and pull to disconnect.
8. Let equipment cool completely before putting away. Store the power cord properly in the storage area provided.
9. To protect against electrical shock hazards, do not expose this equipment to rain, moisture, or other liquids.
10. To avoid electric shock hazard—do not disassemble this equipment, but take it to a qualified serviceman when service or repair is required. Incorrect reassembly can cause electric shock hazard when the equipment is used subsequently.

The serial number of your projector is included on the name plate located on the base casting of the machine. Record the model number and serial number in the space provided below.

Model No. _____ Serial No. _____

IMPORTANT

Before operating projector remove protective plastic coverings on all labels. A piece of tape with the adhesive side touched to the label will remove the protective covering.



TABLE OF CONTENTS

	Page		
AUTOLOAD FILMOSOUND 16mm SOUND PROJECTOR		CARING FOR YOUR PROJECTOR	
Important Safeguards	2	Maintenance and Cleaning	22
Your New Projector	3	Cleaning the Film Path	22
TECHNICAL SPECIFICATIONS, OPTIONS, APPROVALS		Cleaning the Aperture and Pressure Plates	23
Specifications	4-5	Lens Locking System	24
Cautions	5	Cleaning the Lens	24
OPERATING CONTROLS		Replacing the Exciter Lamp	25
Right Side Controls	6	Replacing the Projection Lamp	26
Rear Controls	6	PROBLEM SOLVING	
BEFORE YOU START		Film Condition	27
General Features	7-9	Trouble Shooting	27-28
GETTING YOUR PROJECTOR READY		LENS SELECTION, PROJECTION TABLE	
Setting Up The Projector	10	Accessory Lenses	29
Auxiliary Speaker	11	Filmovara® Zoom	29
USING YOUR PROJECTOR		Anamorphic Lens	30
Using the Autoload System	12	Projection Table	31
Projecting the Film	13-14	ACCESSORIES, REPLACEMENT PARTS	
Reverse Projection	15	Accessory Lenses	32
Bright-Normal Lamp Selection	15	Filmovara Zoom	32
Still Projection	16	Anamorphic Lens (2X)	32
Speed Changing	16	Anamorphic Adapter	32
Directamotion®	17	Projection Lamp	32
Rewinding the Film	18	Exciter Lamp	32
Storing the Projector	19	Film Reels	33
Manual Film Threading	20	Protective Cover	33
Manual Unthreading	21	Orchestricon III Speaker	33
		Directamotion Remote Control	33
		Speaker Cover	33
		Hour Meter	33
		SPECIAL APPLICATIONS	
		Key Installation Dimensions	34

YOUR NEW PROJECTOR

Your new Bell & Howell 16mm Filmosound Projector is top quality equipment designed to give years of reliable performance.

Whether in the school room or the board room, the Autoload feature assures a quick, positive, professional presentation every time. Set up time takes only seconds! The film loads fast and easy—threads automatically. The powerful 20-watt amplifier is solid state—no warm-up time is needed. Just turn the projector on, focus, and you're

ready to show your film.

We are proud of this product which was designed to exacting standards of performance, quality, and durability. These high standards are the reason that more Bell & Howell 16mm projectors are in use today than all other brands combined!

The following material will help you use and enjoy your new projector to the fullest extent of its capability.

SPECIFICATIONS

ILLUMINATION SYSTEM

Lamp	Precision-Aligned Tungsten-Halogen Lamp with integral dichroic reflector 50 Hour/250-Watt/24 Volt Lamp ANSI (Code ELC)—Models 2592/2585. 25 Hour/250 Watt/120 Volt Lamp ANSI (Code BHB)—Model 2590. Bright-Normal Mode Lamp Selection—Models 2592/2585.
Shutter	3-Interruption
Standard	
Lens	Brilliant 2" (51mm) F/1.2 Super Proval Lens—Models 2592/2590. Precision 2" (51mm) F/1.6 Projection Lens—Model 2585. Lens-Locking System prevents unauthorized lens removal.

Optional Lenses	1" (25mm) F/1.6 1.5" (38mm) F/1.5 2.5" (64mm) F/1.5 3" (76mm) F/1.6 4" (100mm) F/1.6 Filmovara® Zoom Attachment for use with 1.5" (38mm), 2" (51mm), 2.5" (64mm), and 3" (76mm) lenses only. Magnification ratio: 0.875 to 1.125 Anamorphic Lens (2X) for use with 1.5" (38mm), 2" (51mm), 2.5" (64mm) and 3" (76mm) lenses only, (no adapter needed) 4" (100mm) lens.* *Anamorphic lens adapter for 4" (100mm) lens.
-----------------------	--

FILM HANDLING CAPABILITIES AND CONTROLS

Reel Arms	Folding; Gear Driven
Film	
Capacity	400 Ft. to 2,000 Ft. (120m to 600m)

Framing Control	Fixed axis, moves only film
Focus Control	Precision Rack and Pinion Shuttle
Film Guide	Three-Tooth Stellite
Rails	Carbo-Nitride Treated
Elevation Adjustment ...	Knob Type, Rack and Pinion
Threading	Automatic
Loop Restorer	Automatic Loop Restorer; Systems Restorer; Loop restorer synchronized with shutter.

ELECTRICAL MODULAR SYSTEMS

Power	120VAC, 60 Hz (Operating range 105 to 132VAC), 350 Watts.
Line Cord	18/3 AWG SJT 9 Ft. (2.74m) length
Protection	Internal via fuses and electronic controls

AUDIO SYSTEM

Amplifier Type	Optical sound track. Plug-in, all Solid State with 20-Watt Output Power (per ANSI specification). Turns on automatically; no warm up time is needed. Overload protection circuit automatically shuts down and protects amplifier in the event of shorted external speaker leads.
Speaker	Built-in 4" x 6"
Auxiliary Speaker	1/4" phone jack provided for 8-Ohm auxiliary speaker with minimum total power rating of 20 Watts.
Tone Control ..	Separate Bass and Treble with approximately 10dB boost and cut (Model 2592). Single Tone Control (Models 2590/2585).

SPECIFICATIONS (CONT'D)

FILM TRANSPORT

Forward Project Sound Speed: 24
Frames/Second (All Models)
Silent Speed: 18
Frames/Second (Does not
apply to Model 2585B)

Reverse Project 24 Frames/Second (All
Models)
18 Frames/Second (Does not
apply to Model 2585B)

Additional Projection Capabilities ... (Model 2592 Only)
Still Picture Control.
Directamotion® feature shows sequential action by stopping and starting the film, one or more frames at a time, in forward or reverse. It always stops "on frame"—no framing required. Directamotion is controlled by lever or remote control.

Cooling System Direct Drive Blower

EXCITER LAMP

Type BAK 4V, 0.75 Amp,
Approximate Life—300
Hrs.

SIZE

14¼" Width
16" Height
10¼" Depth

WEIGHT

34 lbs. (15.4 kg)—Model 2592
29 lbs. (13.2 kg)—Model 2590
33 lbs. (15 kg)—Model 2585

OPTIONS

Accessory Lenses
Protective Cover
Orchestricon™ III Speaker
Directamotion® Remote Control (Model 2592 Only)
Speaker Cover
Hour Meter

APPROVALS

UL Listed

Specifications subject to change without notice.

READ THESE INSTRUCTIONS BEFORE OPERATING THIS EQUIPMENT

CAUTION

This equipment is designed to operate only on 120VAC, 60 Hz current. Operating from any other source may damage the equipment and void the warranty.

Do not attempt to remove the cover or back of the projector; no internal parts are serviceable without specialized equipment and tools.

Keep the lamp house door closed except as necessary for access to the projection lamp. Do not open the lamp house door or look directly at the lamp when lighted, nor touch the lamp, lamp base, plug, or socket while the lamp is lighted.

When changing the projection lamp, allow the equipment to cool thoroughly before handling the lamp. Be sure to unplug the power cord from the wall outlet before attempting to remove the lamp plug from its socket.

When connecting extension speakers to the internal sound amplifier, connect no more than two speakers of 8 Ohms each in parallel.

Ground polarity of the system must be observed and the proper plug used to mate with the jack on the projector. See SPECIFICATIONS, and SETTING UP THE PROJECTOR.

6

OPERATING CONTROLS

RIGHT SIDE

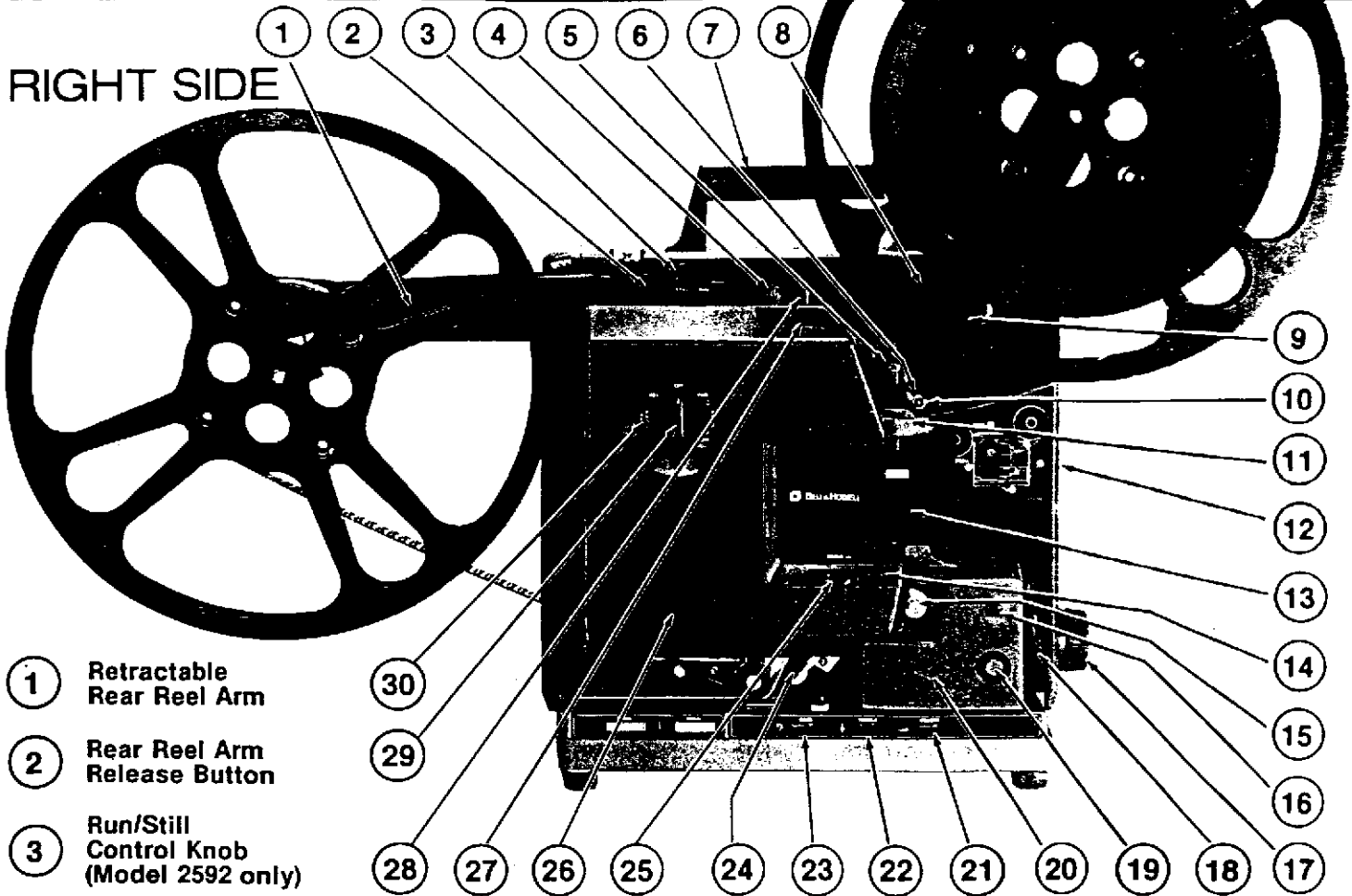

- 1 Retractable Rear Reel Arm
- 2 Rear Reel Arm Release Button
- 3 Run/Still Control Knob (Model 2592 only)
- 4 Framer Knob
- 5 System Restorer
- 6 Autoload Film Guide Roller
- 7 Carrying Handle
- 8 Front Reel Arm Release Button
- 9 Retractable Front Reel Arm
- 10 Sprocket Guards (Behind Cover)
- 11 Film Insert Channel
- 12 Speaker
- 13 Lens
- 14 Stabilizing Rollers (Behind Cover)
- 15 Sound Drum

- 16 Exciter Lamp Indicator
- 17 Tilt Knob
- 18 Film Trimmer
- 19 Exciter Lamp Cover Screw
- 20 Exciter Lamp Cover
- 21 Volume Control
- 22 Treble Control (Model 2592 only)
Tone Control (Models 2585 and 2590)
- 23 Bass Control (Model 2592 only)
- 24 Autoload Threading Lever
- 25 Focus Knob
- 26 Lamp House Cover
- 27 Directamotion Control Lever (Model 2592 only)
- 28 Fast Speed Rewind Button
- 29 Motor Switch
- 30 Control Panel

REAR

- 31 Directamotion® Remote Control Outlet (Model 2592 only)
- 32 External Speaker Jack

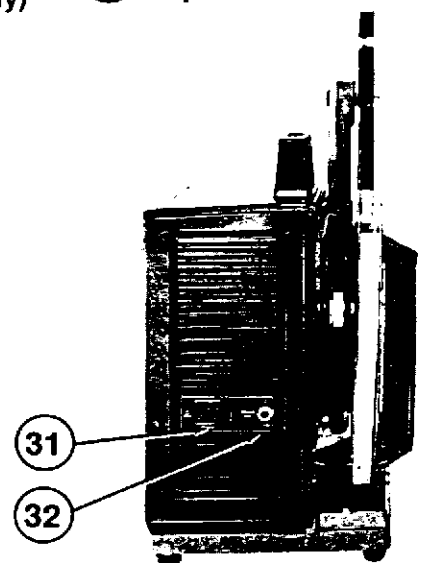

GENERAL FEATURES

The **Carrying Handle** is located atop the projector at a balance point which makes it easy to pick up and move the equipment. Both **Front** and **Rear Reel Arms** are retractable. Each pivots upward from the storage position and locks in the operating position. To retract an arm, depress the **Reel Arm Release Button** by pressing in toward the projector body while moving the arm downward.

The **Motor Switch** turns the projector On and Off and selects **Forward** or **Reverse** projection and lamp **Off**, **On Normal** and **On Bright**.

The **Framer Knob** allows you to properly center the picture within the frame aperture. Turning the knob clockwise raises the image in the aperture; counterclockwise lowers the image.

When rewinding film, raise the **Reel Arm** to upper lock position for reel to reel rewind at the fastest possible speed.

Torn perforations or bad splices will sometimes cause loss of the lower loop below the film gate. The **Automatic Loop Restorer** will reset the lower loop.

If a large portion of film is damaged and the tension is lost around the sound drum, pressing down on the **System Restorer** for at least one second will normally restore the film to the proper threading path.

The **Lamp House Cover** protects the lamp from damage and shields extraneous light from the projection area. Keep the door closed when the lamp is lighted. To open the compartment door, grasp the cover at the top near the **Framer Knob** and pull away from the body of the projector. The **Cover Door** is hinged at the left side and will swing open easily. Spring clips hold the door closed.

The **Focus Control** moves the projection lens forward and back to focus the image on the screen.

Various lenses allow you to obtain optimum screen image size at any distance. See Page 31 for projection table. Each lens is a high quality, multi-element, coated device capable of projecting sharp, bright images.



GENERAL FEATURES

The **Lens Locking System** allows you to secure the projection lens within the **Lens Housing** and discourage unauthorized removal. An Alien head screw and wrench are supplied for locking and unlocking the lens in the lens housing.

Stabilizing Rollers keep the film in proper relationship with the **Sound Drum** during projection, assuring high quality sound reproduction.

A **Tilt Knob** allows you to raise the front of the machine for projection on a screen located above the horizontal axis. To retain a square image, the top of the screen should be tilted toward the projector when the machine is tilted upwards.

An **Exciter Lamp Indicator** monitors the exciter lamp. This convenient indicator assures that this portion of the sound system is ready for normal operation.

The **Exciter Lamp Cover** protects the lamp from damage and prevents extraneous light from escaping. The **Exciter Lamp Cover Screw** secures the cover in a closed position.

The **Still Picture Control** feature (Model 2592 only) allows you to project just a single frame of film. The projector must be running when you move the **Run/Still Control** to the **Still** position.

The **Directamotion®** feature (Model 2592 only—does not apply to export model) allows showing frames one-by-one—in forward or reverse. Directamotion always stops “on frame”. To advance frames a few at a time, move the **Run/Still Control** to **Still**, then simply press down and release the ribbed end of the **Directamotion Control Lever**. To show several frames or a length of film continuously, press and hold down the lever. The Directamotion feature may also be operated with the accessory **Directamotion Remote Control unit**. See ACCESSORIES, on Page 33. Illumination level is decreased during **Still** and **Directamotion** feature use because a heat absorbing filter is inserted to protect film.

A 4" x 6" built-in **Speaker** is included. An auxiliary speaker (8 Ohms minimum recommended) may be plugged into the **External Speaker Jack**.

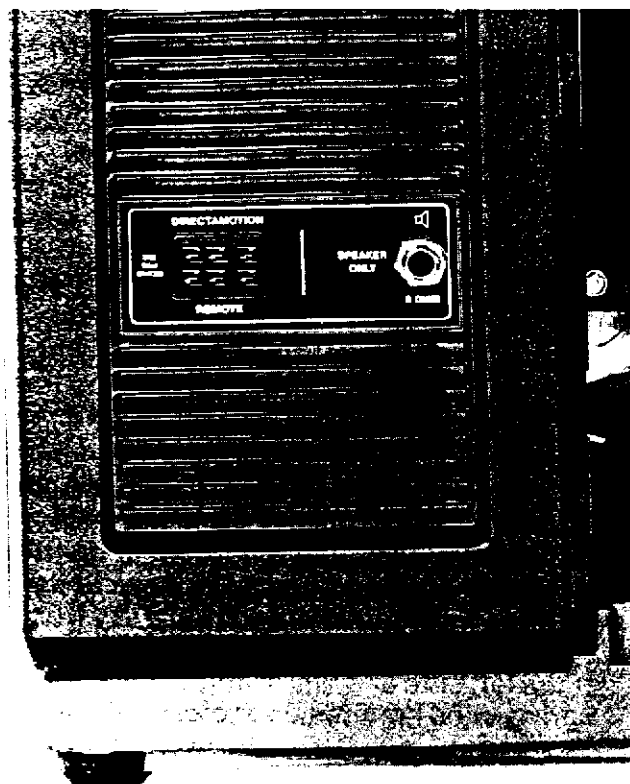
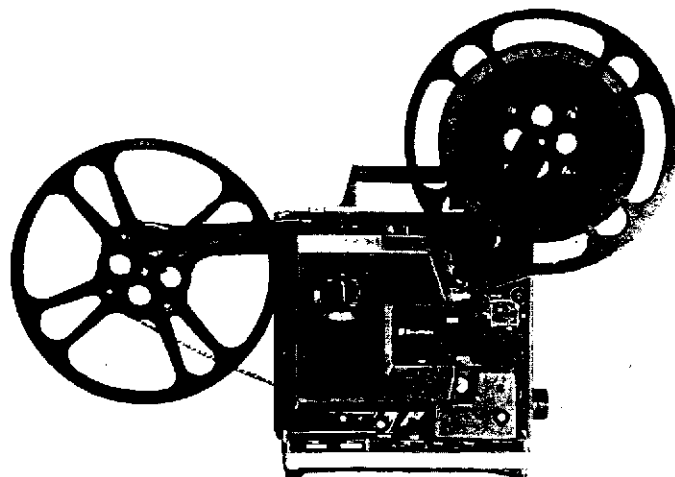

GENERAL FEATURES

The **Film Trimmer** is used to properly trim the film leader if it is damaged or torn.

The **Film Insert Channel** is the opening into which the end of the leader is first inserted as a part of the automatic threading procedure.

Sprocket Guards keep the film in the path and engaged with the sprocket teeth.

When preparing to load film automatically, the **Autoload Lever** is moved forward until it locks into position.

Bright-Normal Lamp selection lets you choose the level of screen illumination that best suits room conditions (Models 2585 and 2592 only). For maximum lamp life, the **Normal Position** will extend life to as much as 300 percent of rated life.

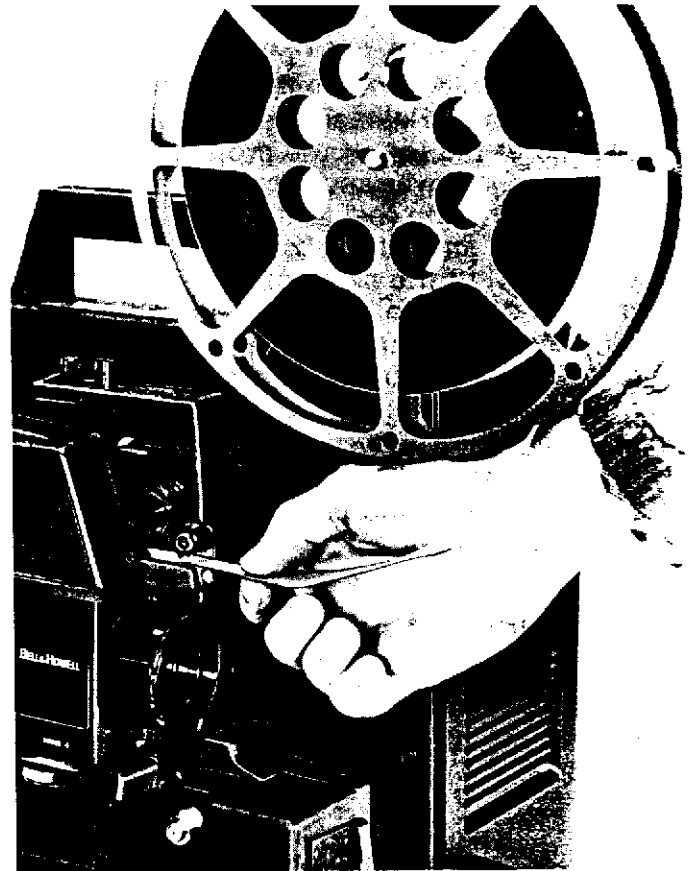

The projector may be operated either at sound speed (24 frames per second) or silent speed (18 frames per second). The **Projection Speed Lever** is locked in the Sound Speed position with the **Speed Lever Locking Screw**. Change from sound to silent speeds by moving the **Projection Speed Lever**. Always be sure the motor is running while changing speeds.

NOTE:

This does not apply to Model 2585B. It operates only at the sound speed (24 frames per second).

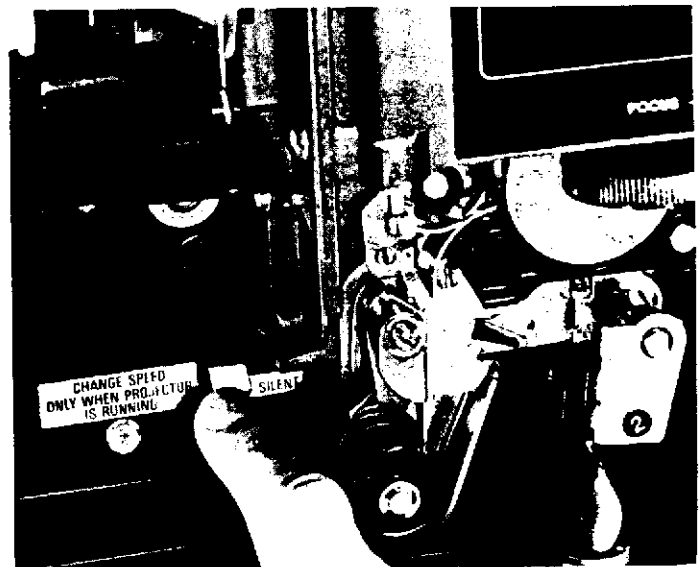

(2590 Pictured)



SETTING UP THE PROJECTOR

Place the projector on a sturdy projection stand or a solid table facing the screen. Be sure the projector is high enough to clear the audience. Release the two locking clamps at the top of the projector housing, unlatch the cover and remove it from the unit. Extend the reel arms; they lock into place with an audible "snap". Select an empty reel of the same size or larger than the reel of film to be projected and place it on the rear take-up arm. Place the reel containing the film to be projected on the front arm.

Make sure the motor switch is in the OFF position. Unwind the power cord from its storage recess and plug it into a 120VAC, 60 Hz grounded outlet.

CAUTION:

This equipment is designed to operate only on 120VAC, 60 Hz current. Operating from any other source may damage the equipment and void the warranty.

Use grounded electrical outlets or an adapter. If an adapter is used, be sure the green wire on the adapter is attached to the screw on the wall outlet plate for proper grounding. Have a trained electrician install the adapter and check the outlet wiring to guard against shock hazard. Faulty wiring may cause damage to the equipment and injury to you.

Turn the motor switch clockwise past position "3" (forward) to the project position. Adjust the tilt control knob and the focus knob to center and sharpen the image area on the screen. Then, turn the switch to the OFF position.

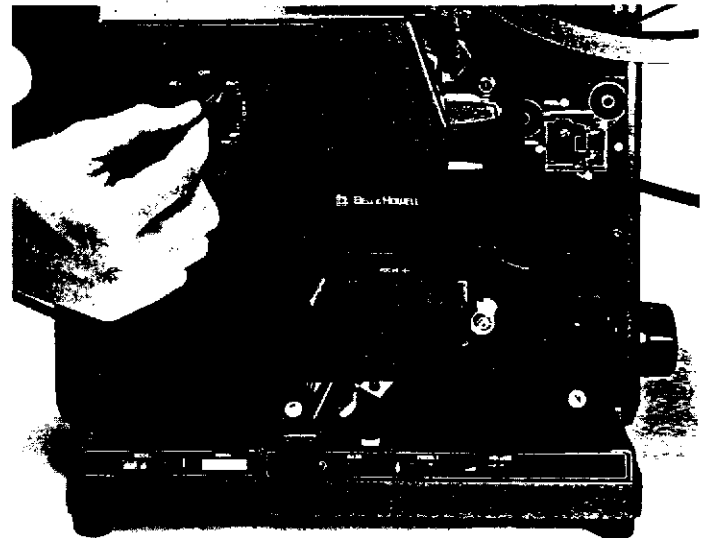
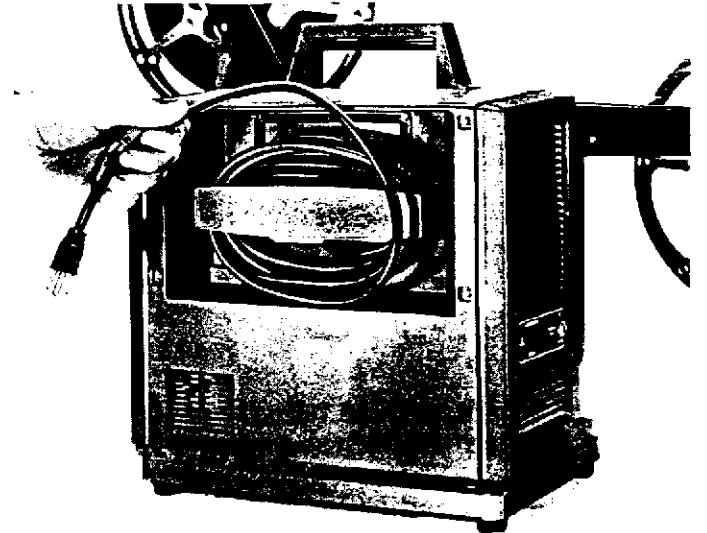
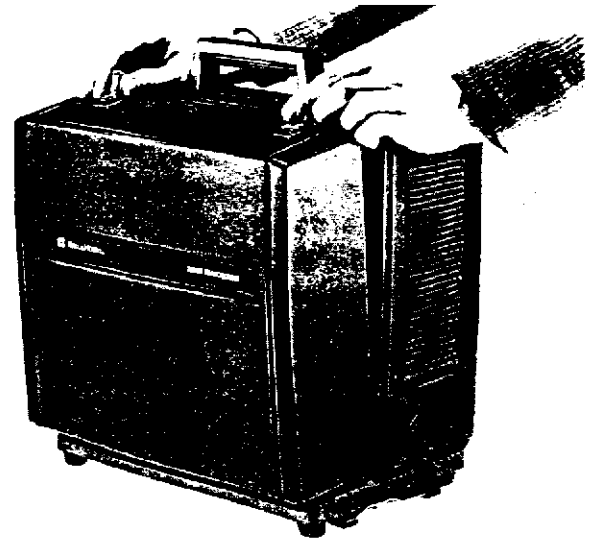



AUXILIARY SPEAKER

If you wish to use an auxiliary speaker or speaker system, it must have a standard 1/4" phone plug to fit into the external speaker jack on the rear of the projector. Locate the auxiliary speaker near the screen for realistic sound.

Optimum performance and sound quality is obtained when using a speaker, or combination of speakers, with a total effective impedance of 8 Ohms, and a minimum total power rating of 20 watts. Reliable operation may also be obtained when using a total load impedance other than 8 Ohms, provided it is not less than 4 Ohms.

CAUTION:

The sound amplifier will automatically turn off in the event of a circuit overload, protecting your projector from any damage. Should this occur, turn off the projector, disconnect the external speaker(s), wait a few seconds, and then restart the projector. If the built-in speaker is operating, the problem is in the auxiliary speaker system. Either the load impedance is less than 4 Ohms, making it incompatible with the projector, or the wiring is faulty. Inspect the auxiliary speaker(s) and the wiring and correct any problems.

Do not attempt to connect this projector to a public address system before consulting your dealer or a qualified serviceman. Proper electronic matching must be provided to prevent system or projector damage.

You may obtain a special instruction sheet for public address system installation by writing to:

General Service-Department 8154
Bell & Howell Company
7100 McCormick Road
Chicago, Illinois 60645

Specify your projector model and serial numbers, if possible, include a schematic or input specifications of the PA system amplifier.

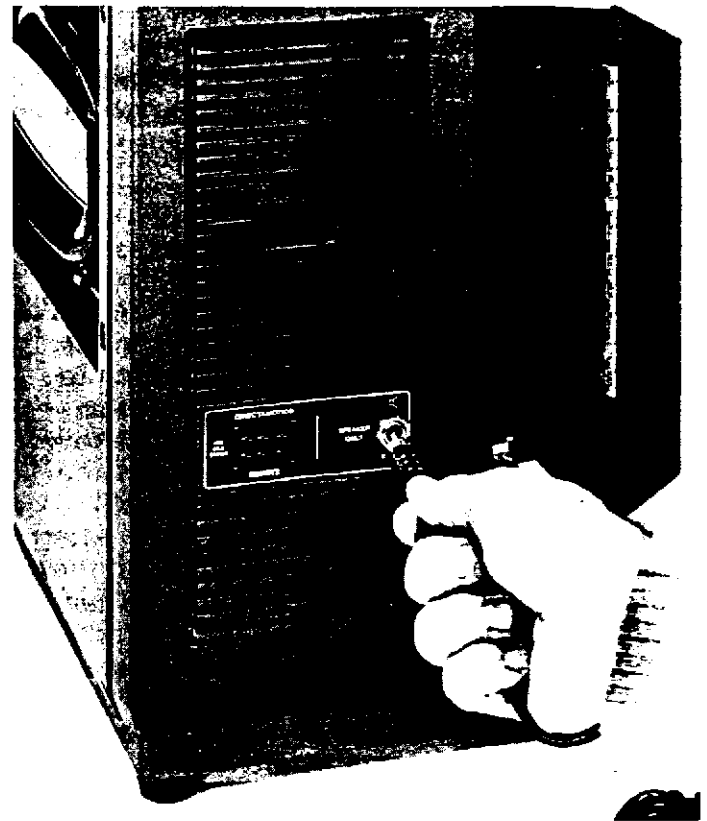

USING THE AUTOLOAD SYSTEM

Check the leader on the film. The first three feet of film (leader) must be free of any defects. If the tip of the film is damaged or torn, insert it into the film trimmer (1") to trim the end. Be sure to engage film perforation on the registration lug of trimmer.

Now you are ready to thread the film with the Autoload system. Push the autoload lever ("2") toward the front of the projector until it locks into the forward position. Make sure the STILL/RUN control lever is in the "RUN" position. Turn the motor switch to the forward position ("3") and insert the leader into the film channel under the roller ("4"). Push the film in until it engages the sprocket. The autoload mechanism will thread the film through the projector. After two feet of leader has passed through the projector, turn the motor switch off. Then pull lightly on the end of the leader until you hear a "click" which signals release of the threading mechanism. Attach the leader end to the take-up reel and rotate the reel clockwise to take up the film slack.

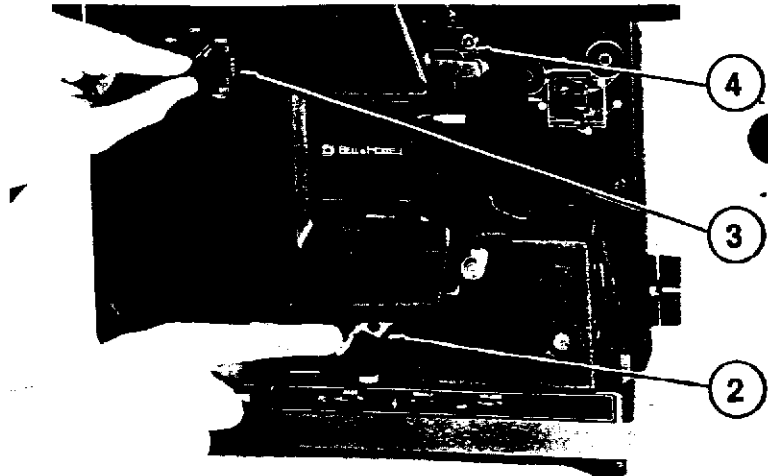
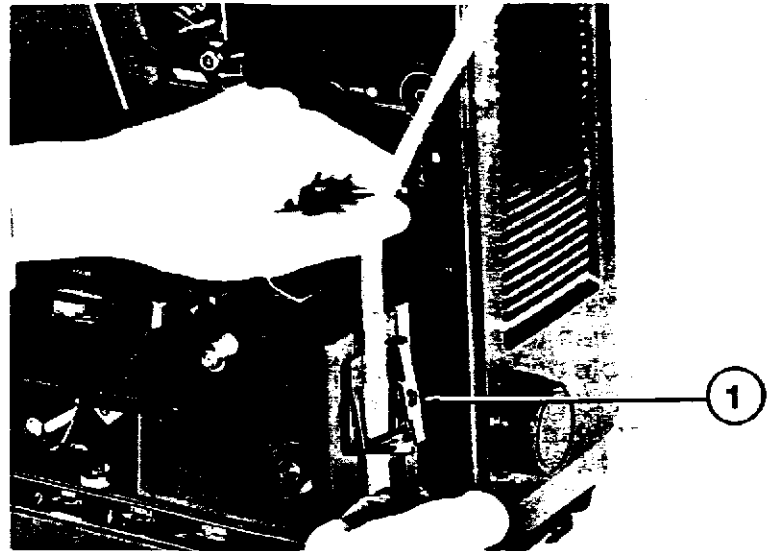

PROJECTING THE FILM

Before the actual showing, whenever possible, the film should be partially projected so that all the operating adjustments can be made ahead of time:

FOCUS CONTROL—Move this knob in either direction to sharpen the image on the screen. It may be necessary to readjust the focus if several types of film are being shown on the same reel.

TILT KNOB—Turn this knob to raise the projector front and center the projected image on the screen.

FRAMER KNOB—Turn this knob to properly center the picture within the frame aperture.

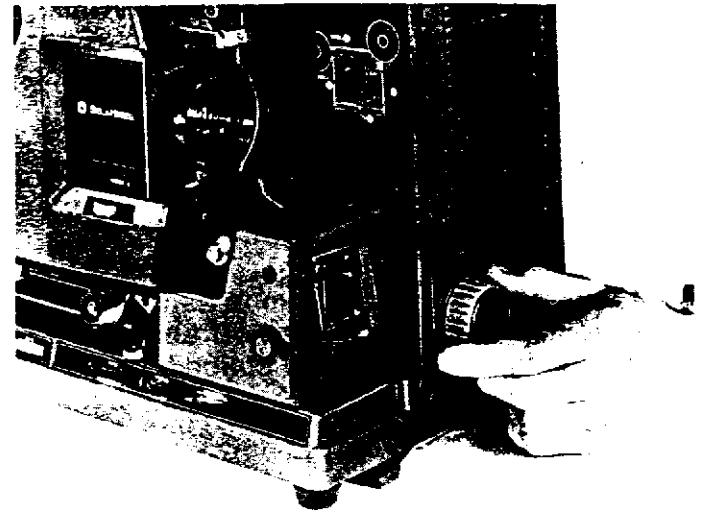
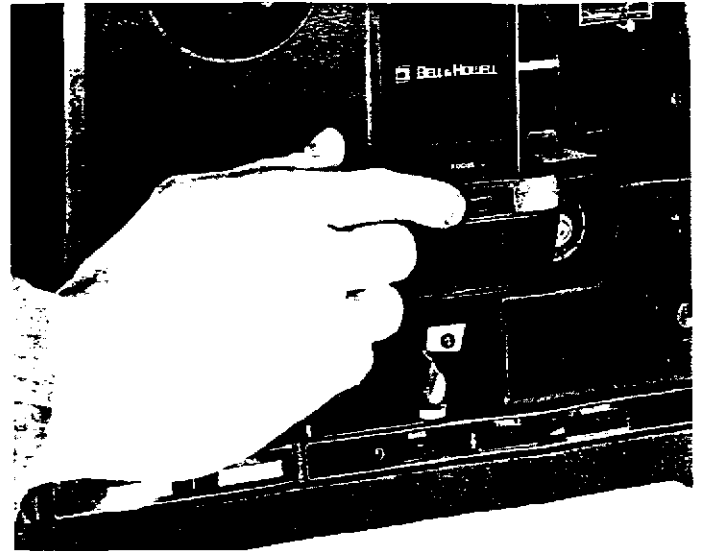

VOLUME CONTROL—Keep the volume at a low setting while the film is being threaded. As soon as the sound appears, turn the control up to a comfortable listening level for the room.

TONE CONTROL—Adjust the bass and treble controls (Model 2592) for the most pleasing tone. On Models 2590 and 2585, a single tone setting adjusts the balance between bass and treble.

AUTOMATIC LOOP RESTORER—Torn perforations or bad splices may sometimes cause a loss of the lower loop below the film gate. If this happens, the automatic loop restorer will correct this loop loss and reset the proper lower loop size automatically.

SYSTEM RESTORER—If a larger portion of film is damaged and if tension is lost around the sound drum, pressing down on the system restorer for at least one second will normally restore the film to the proper threading path.

NOTE:

If a very large portion of film is damaged, the projector must be turned off and the damaged film removed and spliced. (See **MANUAL THREADING AND UNTHREADING.**) No loop restoration is possible during reverse projection.

If you have partially projected your film ahead of time to make all necessary adjustments, be sure to reverse the film to the starting position before the actual presentation.

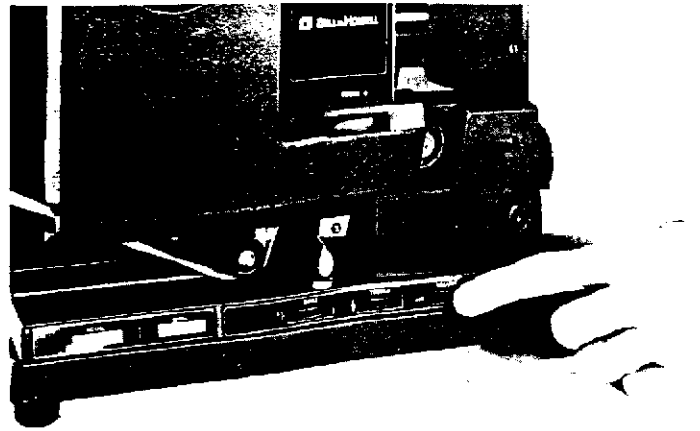

REVERSE PROJECTION

To show your film in reverse or to back the film up to a previous scene, turn the motor switch counterclockwise to the OFF position, pause momentarily, then continue turning past the REVERSE position to the REVERSE PROJECTION position. It may be necessary to reframe the picture. The sound system of the projector does not operate when showing films in reverse (or when showing still or Directamotion pictures—Model 2592 only).

NOTE:

When switching between forward and reverse projection, a momentary pause at the OFF position is necessary to allow the motor to stop and change direction. If the switch is rotated too rapidly, the motor will not change direction.

BRIGHT-NORMAL LAMP SELECTION (Models 2592/2585)

The NORMAL PROJECT position gives lamp illumination for projection under normal conditions and also prolongs the life of the projection lamp. However, at certain times more screen illumination is required. Turn the motor switch clockwise past "5" to the BRIGHT PROJECT position for added illumination when showing films in large auditoriums with long projection distances.

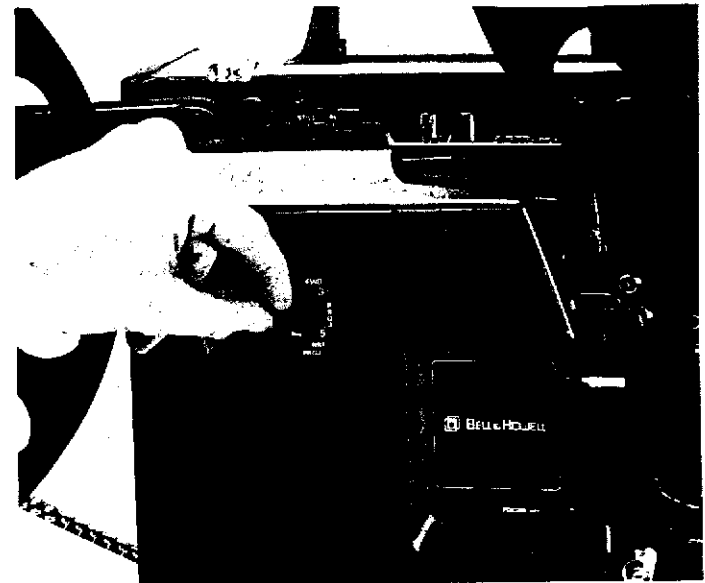
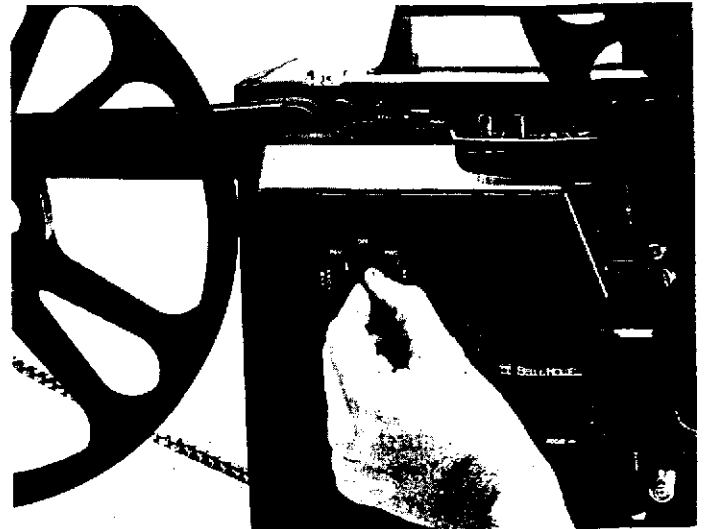

STILL PROJECTION (Model 2592 only)

The run/still control allows you to stop the film in order to view just a single frame of film. For forward or reverse projection in the normal manner this knob is in the RUN position. For still projection, move the control to the STILL position.

NOTE:

The run/still control should be moved to the STILL position only while the projector is running. Moving this control to the STILL position while the projector is turned off may cause damage to the film when the projector is started. When showing a still picture, the image will be dimmed by a heat absorbing filter which prevents damage to the film.



SPEED CHANGING

The projector operates at either sound speed—24 frames per second or silent speed—18 frames per second. Should you wish to change from sound to silent speeds, remove the speed lever locking screw, plug in the projector and turn the motor switch to the forward "3" position so that the motor is running. With the motor running, move the projection speed lever to the SILENT position.

To prevent damage to the equipment, always be sure that the projector's motor is running before moving the projection speed lever. When the projector is being operated in the new position, replace the speed lever locking screw to prevent accidental movement of the lever.

NOTE:

This does not apply to Model 2585B. This projector operates at sound speed (24 frames per second) ONLY.



(2590 Pictured)

Speed Lever
Locking Screw

DIRECTAMOTION® (Model 2592 only)

The Directamotion feature allows you to show frames a few at a time—in forward or reverse.

To use the Directamotion feature, turn the motor switch to either the forward project or the reverse project positions. Then, move the run/still control to the STILL position.

To advance and then view a frame, just press and release the ribbed end of the Directamotion control lever. To advance several frames, or to show a length of film at regular projection speed, press and hold the lever down. Release the lever to stop the film motion.

The Directamotion feature may also be operated with a remote control accessory. The remote control has a sliding button which is used in the same manner as the Directamotion control lever. This remote control accessory plugs into the socket on the rear of the projector.

To resume normal film projection after using the Directamotion feature, just turn the run/still control back to the RUN position.

NOTE:

The run/still control should be moved to the STILL position only while the projector is running.

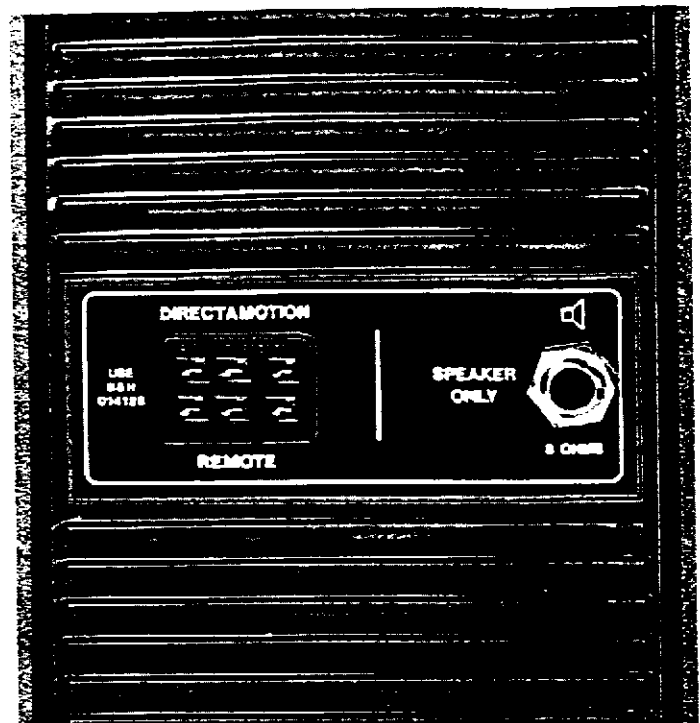
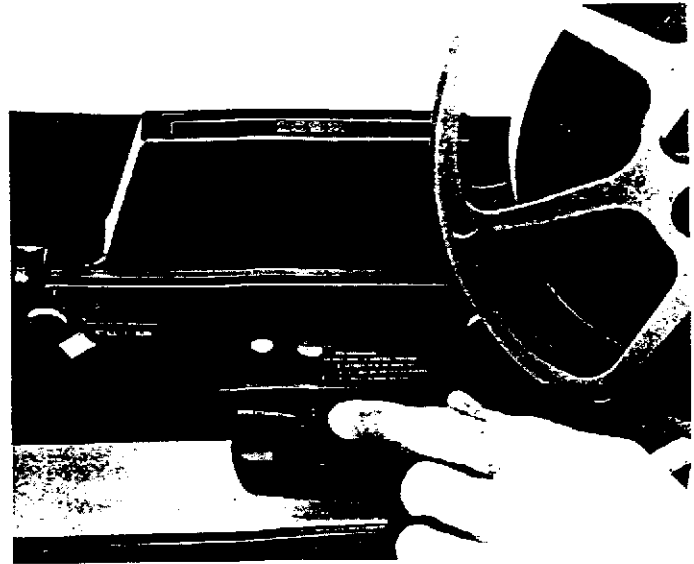

REWINDING THE FILM

After the film is completely shown and all the film is on the take-up reel turn the motor switch OFF. Raise the rear take-up reel arm to the rewind position by pressing in the reel arm release button while swinging the reel arm upward. It will lock into place. Then, unwind the last few feet of film from the take-up reel and attach the end of the film to the hub of the front film reel from the underside. Rotate the front reel counterclockwise about two turns to secure the film.

Turn the motor switch to the REVERSE position and the film will begin to rewind. Press and momentarily hold down the rewind button on the top of the projector to rewind the film at a faster speed. The rewind button will return to the up position as finger pressure is removed.

As soon as all the film is back on the front reel, turn the motor switch off. Press the reel arm release button to unlock the take-up reel arm and move it back down to the take-up position.

NOTE:

The rewind mechanism automatically disengages when the motor switch is turned to forward for the next film showing.

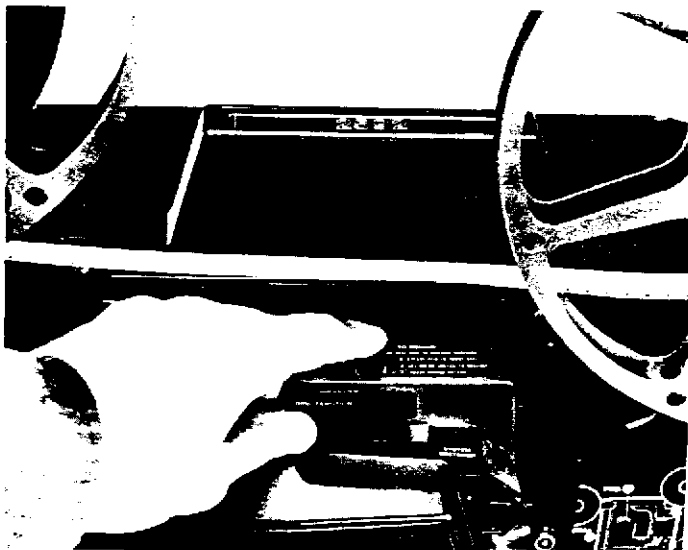
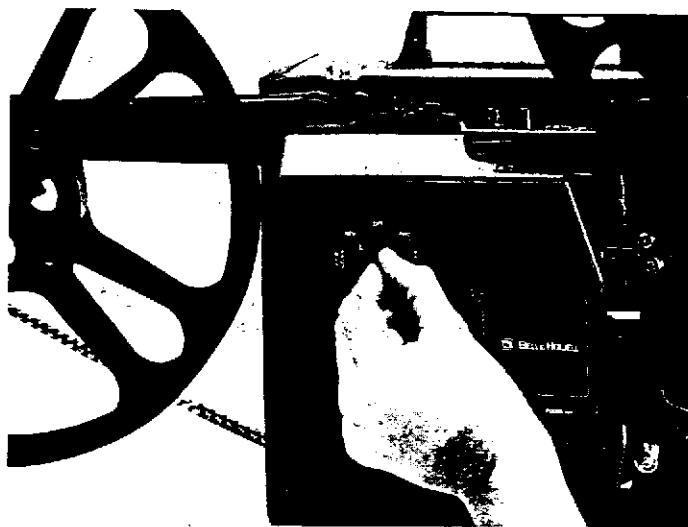
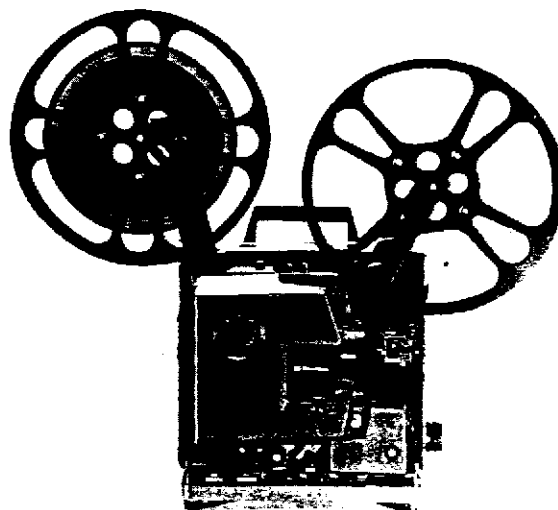

STORING THE PROJECTOR

To store the projector after use, first make sure the motor switch is in the OFF position. Disconnect the power cord from the wall socket and wind it around the cord retainer on the side of the projector.

Remove the reels, press in on the reel arm release buttons, and fold in the reel arms. Lower the projector by turning the tilt control knob. Be sure the run/still control is in the RUN position (Model 2592 only).

Place the front cover on the projector by first fitting the cover's tabs into the recesses in the projector base. Swing the top of the cover into place and snap the two locking clamps on top of the projector firmly shut.

For extra protection during storage and carrying, an accessory vinyl cover with a take-up reel storage pocket is available. See ACCESSORIES Page 33.

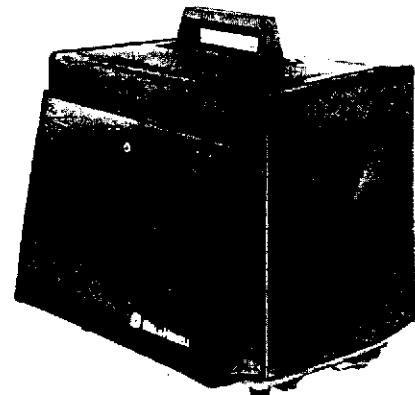
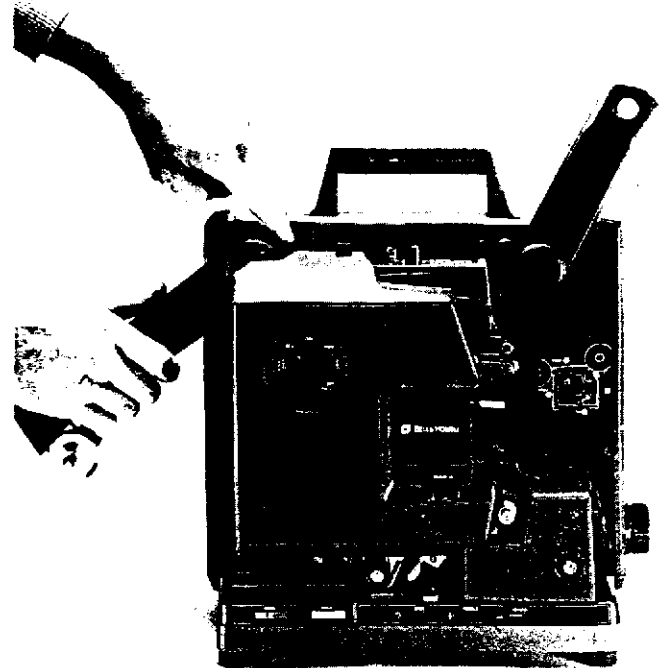

MANUAL FILM THREADING

Normally when setting up the projector you would use the autoloading film threading feature. However, this projector can be threaded manually when necessary, such as starting a film showing in the middle of a reel, for example. To thread manually, follow these instructions and refer to diagram:

Turn motor switch to OFF position. Swing the lamp house cover open by grasping it at the top and pulling it away from the body of the projector. Loosen the exciter lamp cover screw and remove the cover. Open the hinged lens housing by pulling the lens away from the projector.

Push the threading mechanism release roller to the rear of the projector until the threading mechanism snaps open. Open all three sprocket guards—push up on the top two and push down to open the bottom guard.

Thread the film into the projector by slipping it into the threading path from the side starting at the top black roller marked "4". Place the film under this roller.

Place the film under roller "A" and engage the film sprocket holes on the sprocket teeth. Push down to close the sprocket guard.

Position the film in the center of the space

between the film guides and seat the film against the aperture plate between the edge guide rails. Be sure the film is against the aperture plate and behind the guide "D".

Place the film under the roller "E", engage the film sprocket holes on the sprocket teeth and place the film under the roller "G". Close the sprocket guard and close the lens housing.

Place the film between the next two film guides and under the tension roller.

Continue threading the film around the sound drum and over the roller "I". Place the film between the sprocket and the sprocket guard and over the roller "J". Pull on the loose end of the film to separate rollers "H" and "I", then push the film in over the sprocket flange and engage the sprocket holes. Push up to close the sprocket guard.

Place the film in front of guide "N", and under the threading release mechanism roller. Then attach it to the take-up reel.

Replace the exciter lamp cover.

Check the film loop sizes both above and below the aperture for proper size. If the loops are not properly formed, turn the Motor switch to the forward position "3" and press down on the system restorer for at least one second to restore loops.

MANUAL FILM THREADING

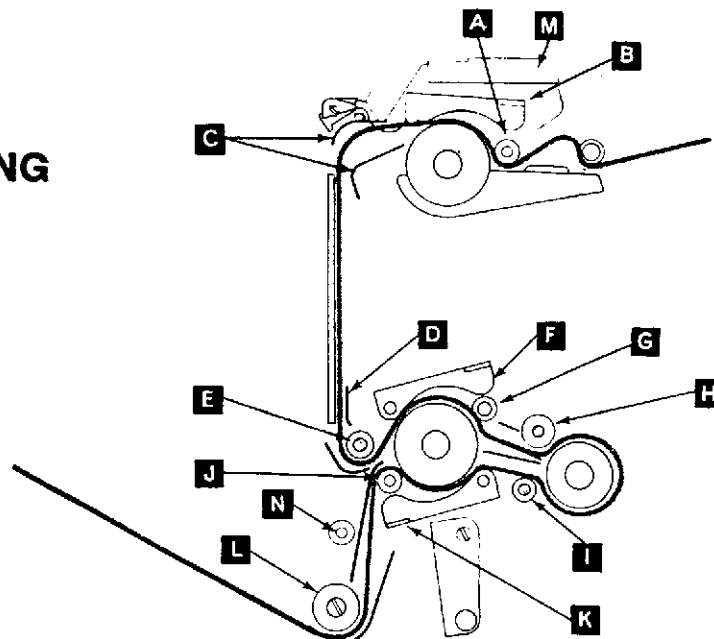

MANUAL UNTHREADING

To remove the film in the middle of a reel, turn **motor switch to OFF position**, swing open the lamp house cover. Loosen the exciter lamp cover screw and remove the cover. Pull open the hinged lens housing.

Turn the front film reel clockwise to provide slack in the film. Open the three sprocket guards. In your right hand grasp the film close to the black roller "4" and ease it out from under the roller.

Hold the film at the black roller with your right hand and just behind the sprocket with your left hand. Push your hands toward each other and ease the film off the sprocket teeth and out from under the sprocket guard.

Next, grasp the film under the loop restorer roller with left hand. Place index finger of right hand on top of the sound drum and push it toward the sprocket. Ease film off the sprocket teeth on top of the lower sprocket. Continue to ease film out from under the stabilizing roller and off the sound drum.

Hold film with left hand at the rear of the lower sprocket and with the right hand below the sound drum. Push upward to ease the film off the sprocket teeth at the bottom of the lower sprocket. Slide the film out of the bottom film channel.

Leaving the reels on the reel arms, proceed with rewinding as described on Page 34. After rewinding, reinstall the exciter lamp cover, close the lens housing, and swing closed the lamp house cover.

NOTE:

If film was manually unthreaded because of poor splices or torn perforations, be sure the damaged section is removed and the film properly spliced before rewinding.

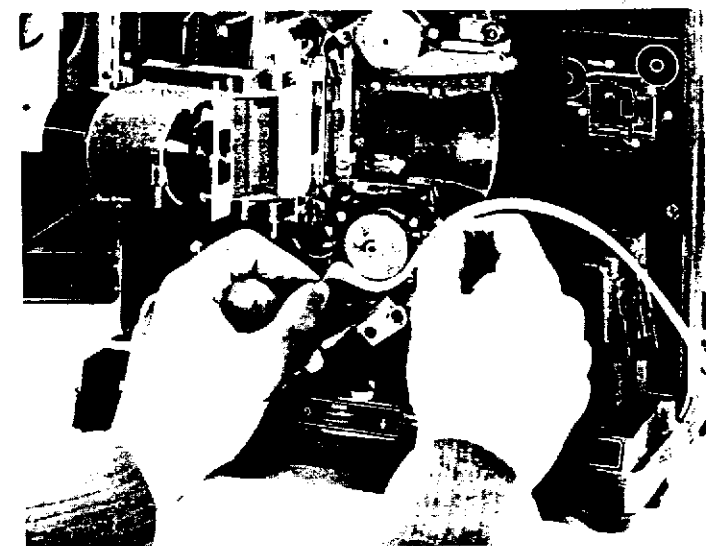
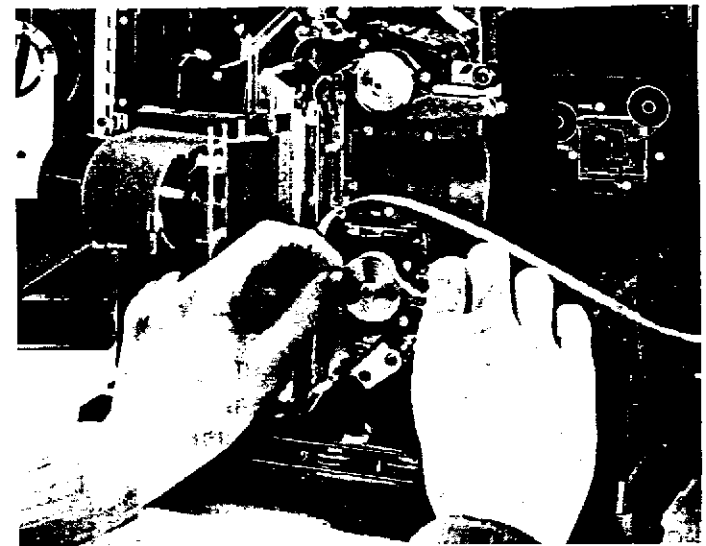
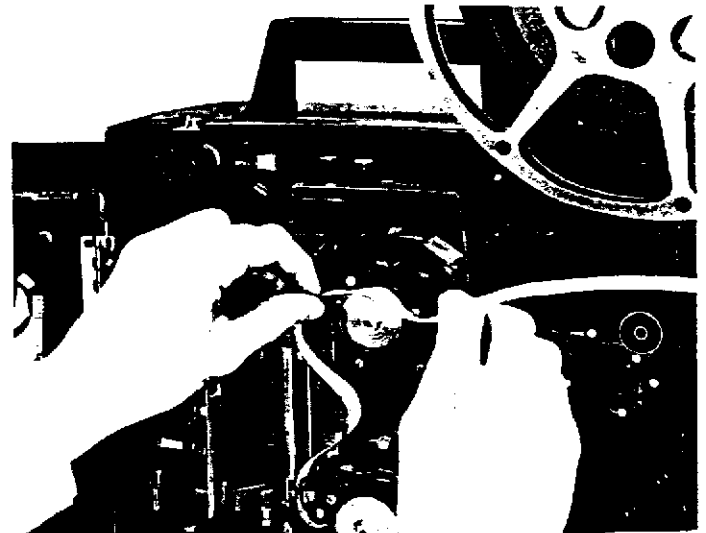

MAINTENANCE AND CLEANING

Your Bell & Howell projector has been designed and engineered for long, trouble-free service with a minimum of maintenance. Factory lubrication is built-in; you'll never need to oil this projector. Permanently lubricated bearings mean extended service and longer life. Many parts which normally wear are adjustable, eliminating the need for frequent replacement.

Periodic maintenance is required, including cleaning and occasional replacement of some parts. Instructions for simple procedures follow. We recommend that you seek factory approved service from your Bell & Howell Approved Service Station periodically to assure that your equipment remains in first-class operating condition.

CAUTION:

Do not attempt to remove the back cover of the projector; no internal parts are serviceable by the user. Specialized equipment and tools are necessary.

CLEANING THE FILM PATH

To prevent damage to the film, all surfaces that contact the film must be cleaned frequently. **Projector and lamp must be turned off before beginning cleaning.**

To reach the film path swing open the lamp house cover. Wipe all threading guides with a soft cloth or brush which has been moistened with any naphtha-based agent such as lighter fluid. Remove the exciter lamp cover (see section on replacement of exciter lamp) to clean the sound drum and the film guide that is part of the exciter lamp cover. Gently clean both sound drum stabilizing rollers. Remove any loose particles that may have become lodged in the film threading path. Before cleaning this area of the projector, be sure all projector parts have cooled.

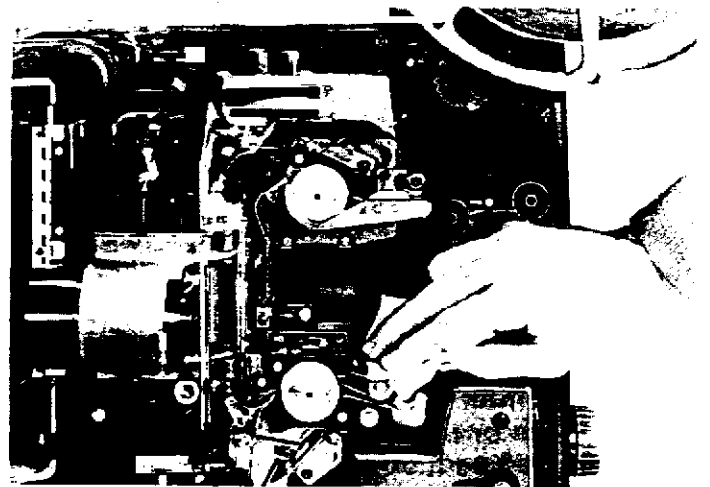
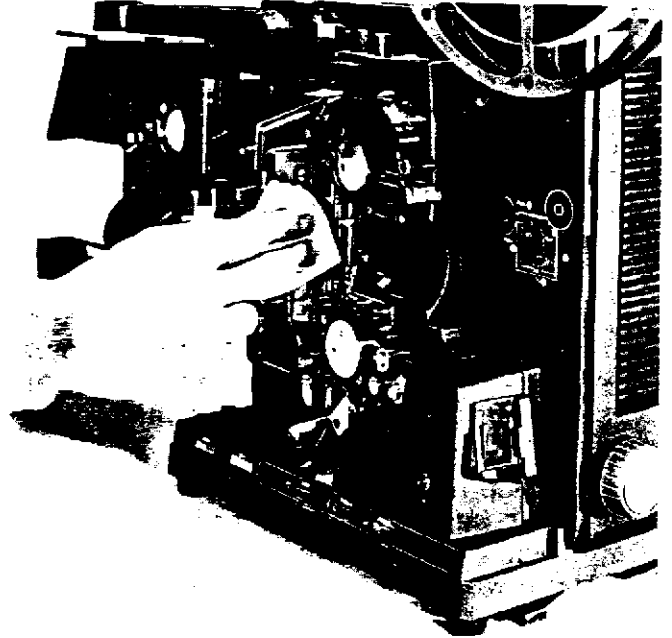

CLEANING THE APERTURE AND PRESSURE PLATES

Assure that the projector and lamp are turned off. Open the lens housing by swinging it out from the projector. Gently wipe the aperture and pressure plates with a cloth moistened with lighter fluid or naphtha based solvent to remove accumulated dirt or emulsion. Also clean the aperture side tension rails and the aperture opening. Be sure to press in on the side tension rail and clean the area of the aperture plate behind the side tension rail. After cleaning, gently swing the lens housing back into position; be sure the pressure plate seats properly. Snap the housing closed.

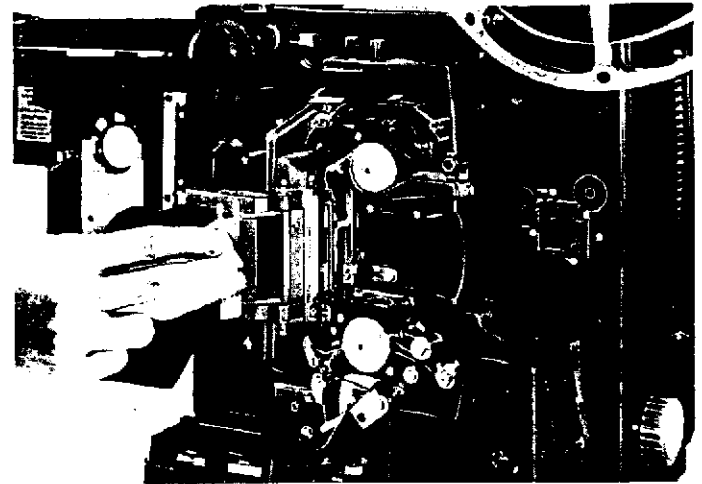
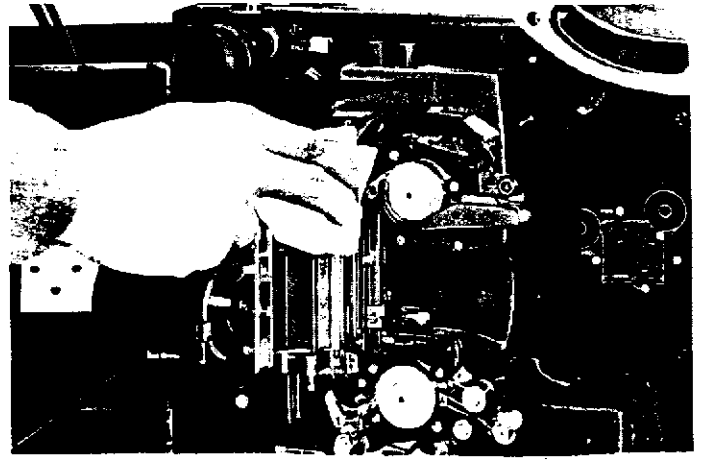

CLEANING THE LENS

To discourage unauthorized removal, the projection lens may be secured in the lens housing with a lens locking system consisting of an Allen screw and wrench (supplied with the projector). To install the screw, pull the lens housing out and insert the screw in the threaded hole at the bottom of the housing. Have the lens focused all the way in when inserting the screw. To remove or change the lens, just back the screw out with the wrench. Store the wrench in a safe place.

If the lens locking screw has been installed, take the Allen wrench and back the screw out far enough so that the lens can be removed. Turn the focus knob to the left to move the lens out as far as it will go. Then, grasp the lens barrel and remove it from the housing. Use a lens tissue or soft cloth moistened with lens cleaner to wipe dust and fingerprints off front and rear lens surfaces. When lens is clean, insert it back into the lens housing, turning the focus knob to the right to engage the lens. If the lens locking screw has been used, turn it back to secure the lens.

After cleaning is complete, close the lens housing and shut the lamp housing.

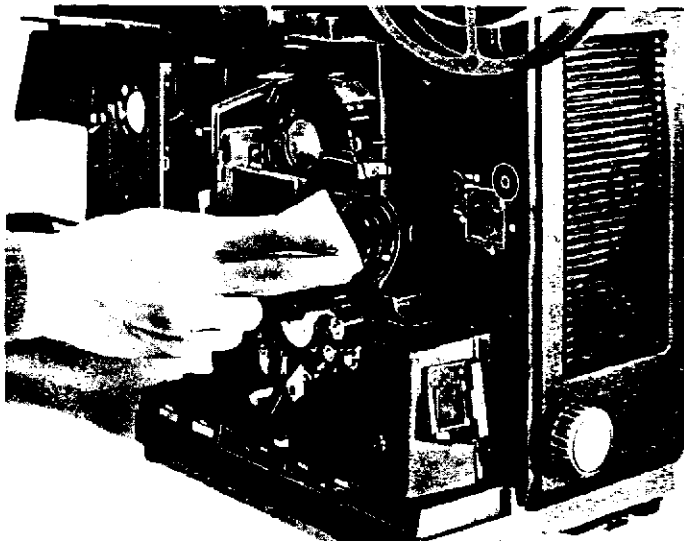
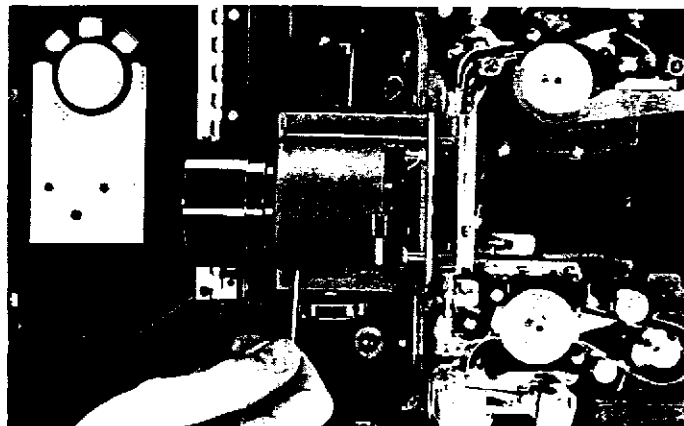

REPLACING THE EXCITER LAMP

Before starting to replace the exciter lamp, turn the motor switch to the OFF position and disconnect the power cord. Loosen the exciter lamp cover screw and remove the cover by pulling straight out. Note the registration pins which align the cover. Move the exciter lamp lock lever to the right to release the lamp. Then rotate the lamp counterclockwise and lift it off the guide pins.

Place the new lamp (ANSI Code BAK) over the guide pins and rotate the lamp clockwise. Move the lamp lock lever to the left to lock the lamp base firmly in place. The notch in the lamp base flange should be facing forward when installing the new lamp.

Replace the exciter lamp cover; be sure to match the two registration pins to the two holes in the projector to align the cover. When the cover is firmly seated in place, hold it securely and tighten the screw.

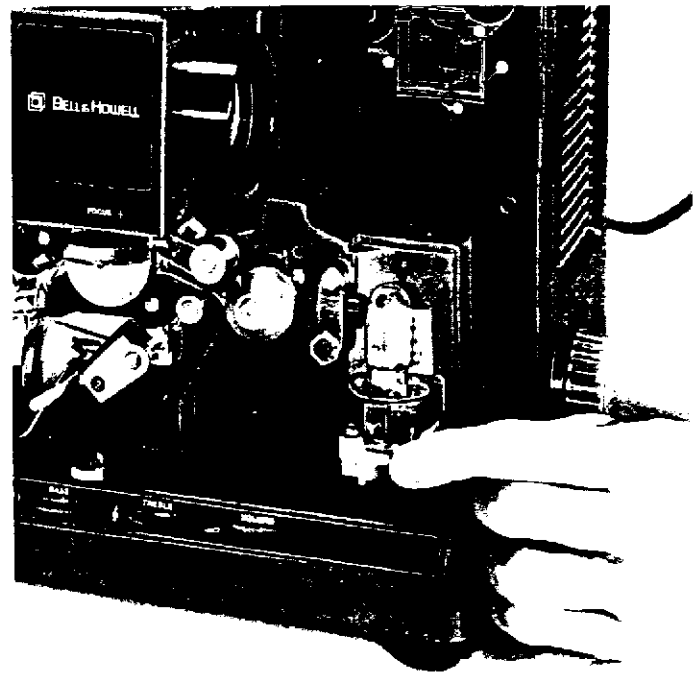
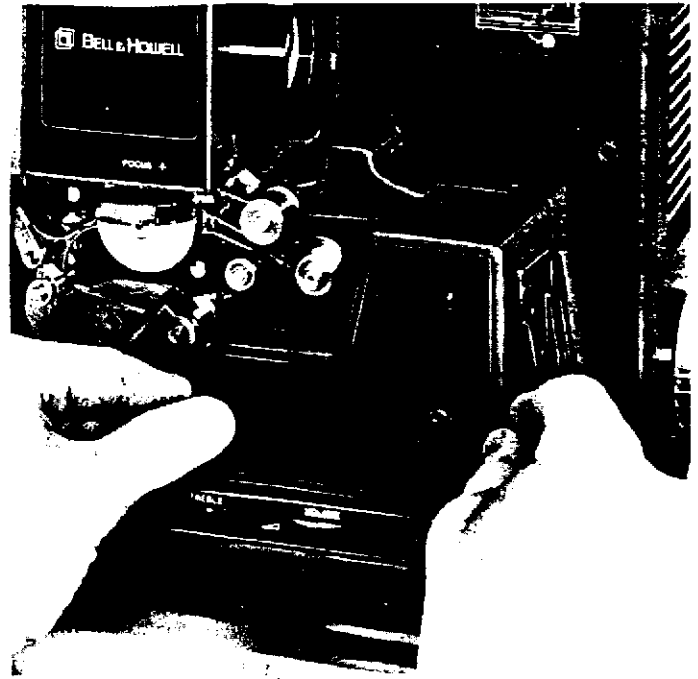

REPLACING THE PROJECTION LAMP

Turn the motor switch to the OFF position and disconnect the power cord. Allow the equipment to cool before attempting to handle the lamp.

FOR MODELS 2592/2585:

Swing the lamp house cover open. Press the top of the lamp retainer to release it from the clip; it is flexible enough to be out of the way for replacing the lamp. Then unplug the lamp from the socket, plug in the new lamp and place the new lamp in position in the projector. The socket wires must point downward toward the projector base. Refasten the lamp retainer and close the lamp house door.

FOR MODEL 2590:

Swing the hinged lamp housing out and to the rear. Swing the lamp holder clamp downward. Grasp the lamp by the black rear portion and pull it straight out. **CAUTION:** If the lamp is still warm or hot, use a glove or heavy cloth to hold the lamp base. Insert the new lamp, reflector forward, by aligning the pins with the socket and pushing straight in. Push the lamp clamp back up until it snaps into position. Swing the lamp housing closed, insuring that it has snapped firmly into place.

NOTE:

Use ANSI Code ELC lamps with models 2592/2585. Use ANSI Code BHB lamp with model 2590.

Remember, handle the lamp only by the outer reflector shell or ceramic base; do not touch the inside of the reflector or bulb.

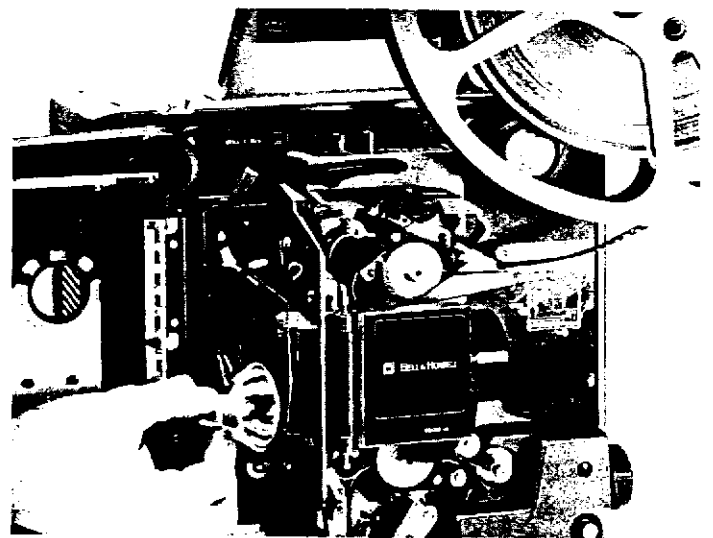
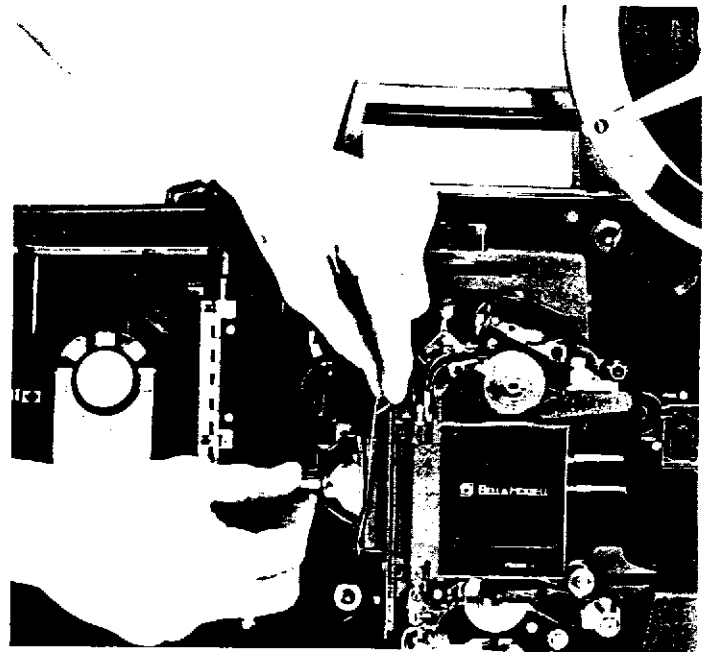

FILM CONDITION

Your projector is designed with special features to help protect your film from damage. Although it is designed to accept film in virtually every conceivable condition, there are certain film irregularities that the projector may not handle properly or which may cause threading difficulties.

Should your film be forced up and out of the projector's threading mechanism, immediately turn the motor switch OFF and remove the film for inspection and repair.

The following conditions can cause threading difficulties:

FILM LEADER—The first three feet of film (the leader) is very important in an autoloader system. If there is any doubt about the condition of the leader, splice on new leader material.

DRY FILM—It has a tendency to crack and break. The film end should be replaced with new leader and in many cases all of the film on the reel should be cleaned and relubricated.

MARKED LEADER—Leader with tape, staples, grease pencil, or identifying marks on it should be corrected or replaced.

TORN PERFORATIONS—Whether at the leader end of the film or within the reel, torn perforations should be cut out. Replace with new leader at the start of the film.

BUCKLED OR WARPED FILM—Replace with new leader.

FILM CURL—If curl is tighter than 4" diameter, replace the leader.

SPLICES—If a splice should break in the middle of a showing, stop the projector, trim the end of the film from the front reel, rethread the projector and continue the film using another rear reel. When rewinding, stop the film at the break and splice.

BUCKLED OR WARPED SPLICES—Correct to prevent future problems.

MISALIGNED SPLICES—A misaligned splice can cause projection problems especially if it is in the leader portion of the film. Resplice correctly.

STAPLED SPLICES—For emergencies only. Be sure they are taken out before the film is rewound or reshown.

TAPE SPLICES—Take care to see that they align perfectly with the sprocket holes in the film.

NOTE:

Film being used for the first time must be trimmed using the film trimmer. Any ragged end, bend, or extremely tight curl must be cut off to allow proper film threading.

TROUBLE SHOOTING

The following information includes a variety of symptoms, a test which will pinpoint the nature of the trouble, the cause of the trouble, and a remedy. Many of the

symptoms described may not ever be encountered during the life of the projector; this information is provided as a guide should the condition ever exist.

SYMPTOM	TEST	CAUSE	REMEDY
Projector completely inoperative.	Is power cord plugged in? Is motor switch in forward position? Does electrical outlet have current?	If yes to all tests, internal power supply is not working.	Return projector to service station.

TROUBLE SHOOTING (CONT'D)

<p>Film does not thread automatically.</p>	<p>Is autoload lever #2 pushed forward? Is motor switch in forward position? Is film leader in good condition and properly trimmed? Is the lens housing closed, the exciter lamp cover firmly in place, the film threading path free of obstructions? Is the run/still control (Model 2592) in the run position?</p>	<p>If yes to all tests, electrical/mechanical problem.</p>	<p>Return projector to service station.</p>
<p>SYMPTOM Exciter lamp lights but no sound comes from speaker.</p>	<p>TEST Is the film properly threaded? Is the volume turned up? Is the film soundtrack adequate? Remove film from projector. Turn motor switch to forward. Make sure run/still control (Model 2592) is in the run position. Pass a card swiftly back and forth between the sound drum and the lens adjacent to the exciter lamp; listen for thumping noise. If external speaker is used, unplug and check for proper operation with internal speaker.</p>	<p>CAUSE Internal failure. If thump, faulty film soundtrack. Faulty external speaker system.</p>	<p>REMEDY Return projector to service station. Replace or repair external speaker.</p>
<p>SYMPTOM Exciter lamp does not light; no sound from speaker. Sound volume is not adequate; fuzzy, garbled.</p>	<p>TEST Is exciter lamp burned out? Is external speaker(s) at 4 Ohm minimum load? Check for overload shut-down condition. Is volume control set high enough? Is tone control set properly? Is film tight around the sound drum? Is film clean? Is exciter lamp filament damaged?</p>	<p>CAUSE Exciter lamp is bad. Auxiliary speaker may be loose. Internal failure.</p>	<p>REMEDY Replace lamp. Tighten speaker cable. Return projector to service station. Correct overload. Clean film. Replace exciter lamp. If symptom continues, return projector to service station.</p>
<p>SYMPTOM No picture</p>	<p>TEST Is motor switch in the project position? Is projection lamp burned out?</p>	<p>CAUSE If setting is right, bad lamp.</p>	<p>REMEDY Replace lamp. If symptom continues, return projector to service station.</p>

ACCESSORY LENSES

A variety of accessory projection lenses are available to give sharp, brilliant movies in every projection situations. Ranging from 1" (25 mm) through 4" (100 mm) in discrete lenses, and including Filmovara® Zoom Attachment, and Anamorphic attachments (may not be used together), virtually every screen size can be filled at projection distances up to 200 feet. It is best to have a lens of the right focal length to fill the screen. The focal length required will vary according to screen size and distance between the projector and screen. The projection table that follows will show the relationship between lens focal length, screen size, and distance. It is best to have the projector located as far toward the rear of the room as possible to avoid obstructing the view of your audience.



FILMOVARA® ZOOM ATTACHMENT

The Filmovara Zoom Attachment will enable you to project a variety of image sizes with a single lens. The Filmovara attachment can be used with the following lenses:

- 1.5" (38 mm) F/1.5
- 2" (51 mm) F/1.2 or F/1.6 standard lens
- 2.5" (64 mm) F/1.5
- 3" (76 mm) F/1.6

The magnification ratio ranges from .875 to 1.125. See projection table for the span of screen size/distances you can achieve with this attachment.

To use the Filmovara Zoom Attachment, screw it clockwise onto the front of the projection lens. Revolve the rear, black, knurled collar of the attachment until the image fills the width of the screen at the selected projection distance. Clockwise rotation of the ring decreases picture size; counterclockwise rotation increases picture size. Sharpen the image with the focus knob as with any other lens.

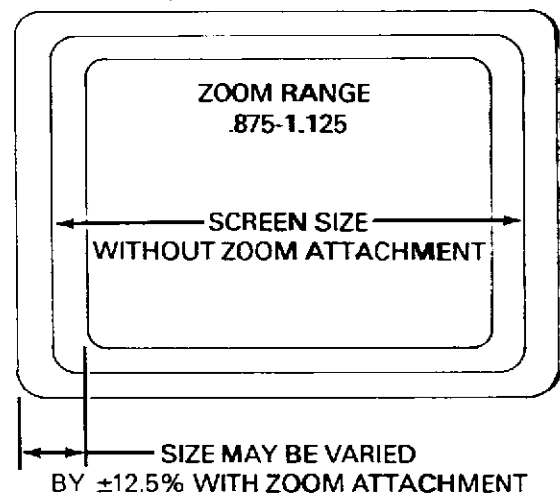

ANAMORPHIC LENS (2X)

The Anamorphic lens will enable you to show wide-screen 16 mm films. This lens doubles the width of the projected image without altering the height. This accessory fits the following lenses:

- 1.5" (38 mm) F/1.5
- 2" (51 mm) F/1.2 or F/1.6 (standard lens)
- 2.5" (64 mm) F/1.5
- 3" (76 mm) F/1.6
- 4" (100 mm) F/1.6 (with special adapter)

To use the Anamorphic lens:

1. Screw the Anamorphic lens into the front of the projection lens.
2. Rotate the two assembled lenses to orient the image on the screen.
3. Position the projector to fill the width of the screen.
4. Set the projection distance on the Anamorphic lens barrel.
5. Sharpen the image with the FOCUS CONTROL. (See Page 13).

The Anamorphic lens cannot be used with the Filmovara Zoom lens.

Note:

This projector is equipped with a lens locking system (the lens lock works only with standard 2" lenses). See the section on CLEANING THE LENS Page 24 for instructions on changing lenses.

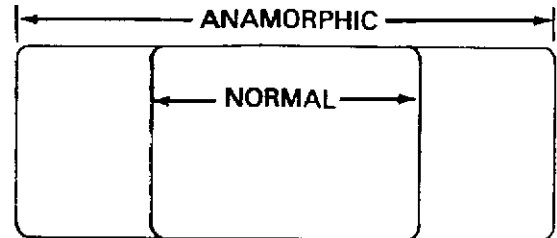



PROJECTION TABLE

This table shows the relationship between lens focal length, screen size and distance. It is based on the equation:

$$\text{Screen Width (feet)} = \frac{.38 \times \text{Projection Distance (feet)}}{\text{Focal Length (inches)}}$$

For example: a 10 foot wide screen used with a 2" (50mm) lens requires a projection distance of 52 feet. When Filmovara® Zoom attachment is used, the projection distance can vary from 46 feet to 58 feet. Or, the Filmovara attachment could be used to adjust the image width from 9 feet to 11.2 feet at a fixed projection distance of 52 feet.

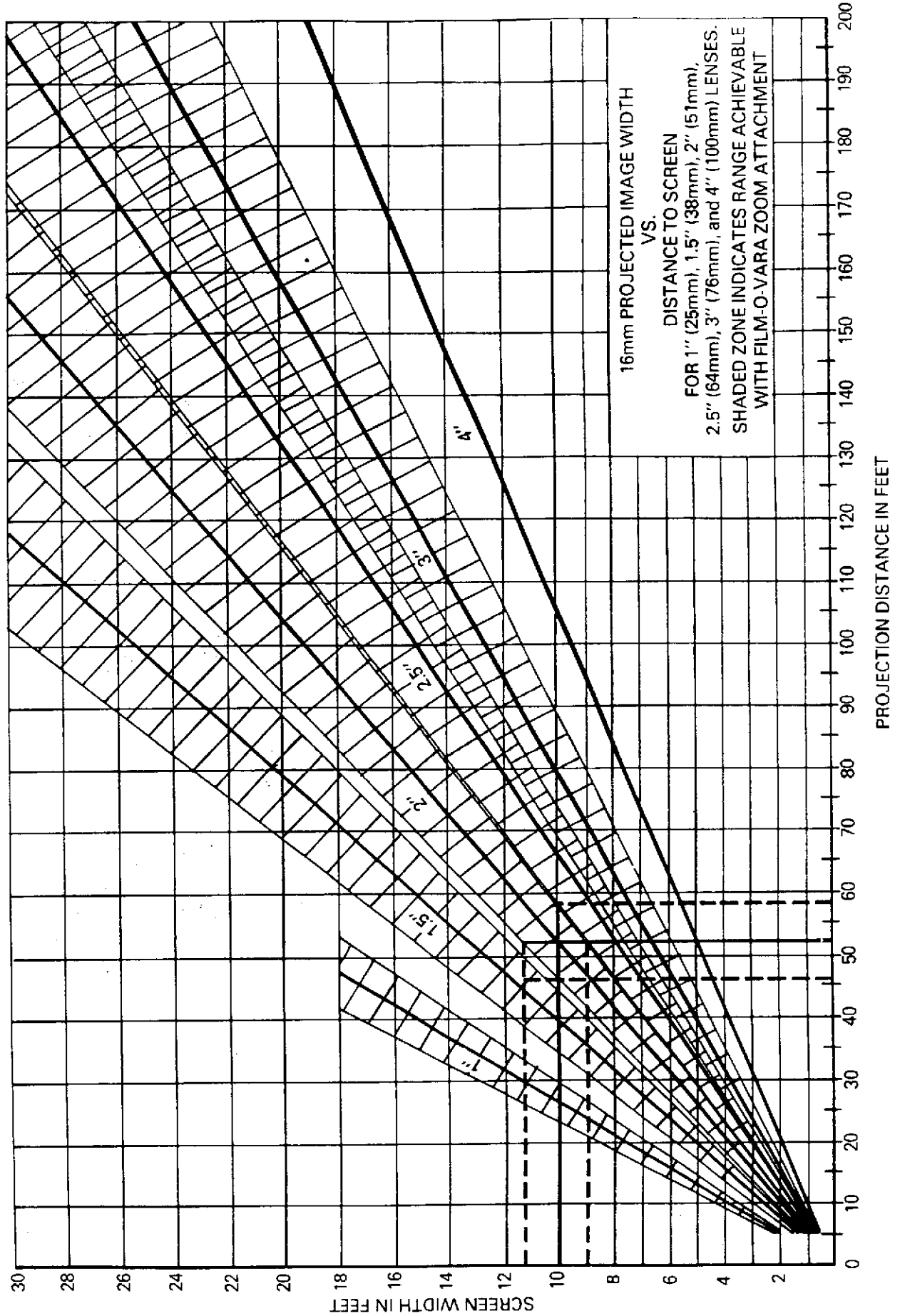

16mm PROJECTED IMAGE WIDTH
VS.
DISTANCE TO SCREEN
FOR 1" (25mm), 1.5" (38mm), 2" (51mm),
2.5" (64mm), 3" (76mm), and 4" (100mm) LENSES.
SHADED ZONE INDICATES RANGE ACHIEVABLE
WITH FILM-O-VARA ZOOM ATTACHMENT

ACCESSORY LENSES

1" (25mm) F/1.6

Bell & Howell Part No. 204595

1.5" (38mm) F/1.5

Bell & Howell Part No. 204441

2.5" (64mm) F/1.5

Bell & Howell Part No. 204442

3" (76mm) F/1.6

Bell & Howell Part No. 204443

4" (100mm) F/1.6

Bell & Howell Part No. 201004

FILMOVARA® ZOOM ATTACHMENT

Bell & Howell Part No. 204665

For use with 1.5" (38mm), 2" (51mm), 2.5" (64mm), and 3" (76mm) lenses.

Magnification ratio: .875 to 1.125.

ANAMORPHIC LENS (2X)

Bell & Howell Part No. 204440

For use with 1.5" (38mm), 2" (51mm), 2.5" (64mm), 3" (76mm), and *4" (100mm) lens.

*ANAMORPHIC ADAPTER

Bell & Howell Part No. 204287

Required with 4" lens.

PROJECTION LAMPS

Bell & Howell Part No. 710396 (ELC)

Bell & Howell Part No. 44223 (BHB) (not shown)

EXCITER LAMP

Bell & Howell Part No. 34884 (BAK) (not shown)

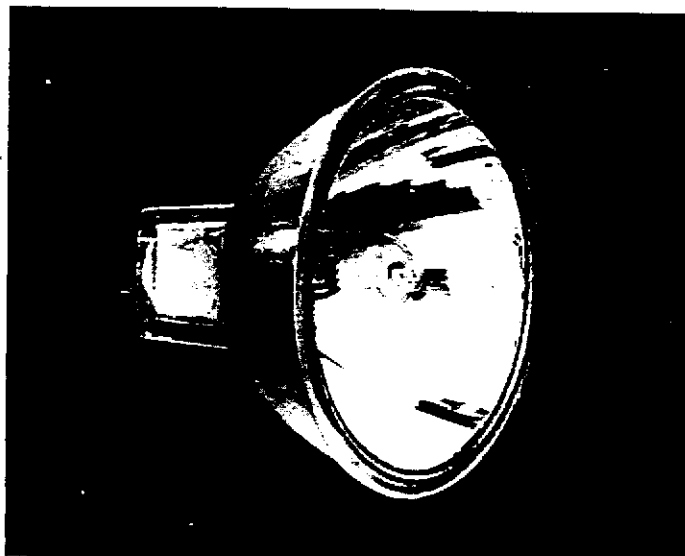
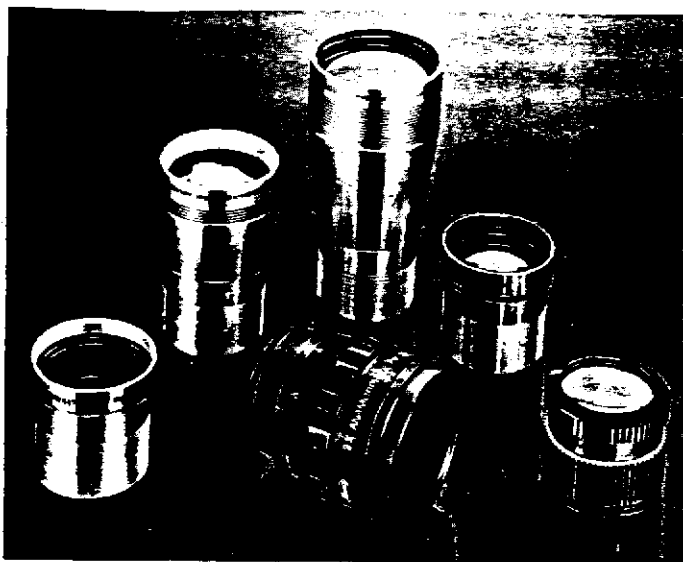

FILM REELS (not shown)

400' (120m) Plastic Take-Up Reel

Bell & Howell Part No. 710365

400' (120m) Standard Metal Reel

Bell & Howell Part No. 710138

1600' (500m) Standard Metal Reel

Bell & Howell Part No. 01873

2000' (600m) Standard Metal Reel

Bell & Howell Part No. 03727

PROTECTIVE COVER

Bell & Howell Part No. 44468

Bell & Howell Part No. 707788 (for projectors with speaker covers)

This cover slips over the projector and protects it from dust and damage while in storage and while being transported from place to place. Built-in pocket will hold a large film reel.

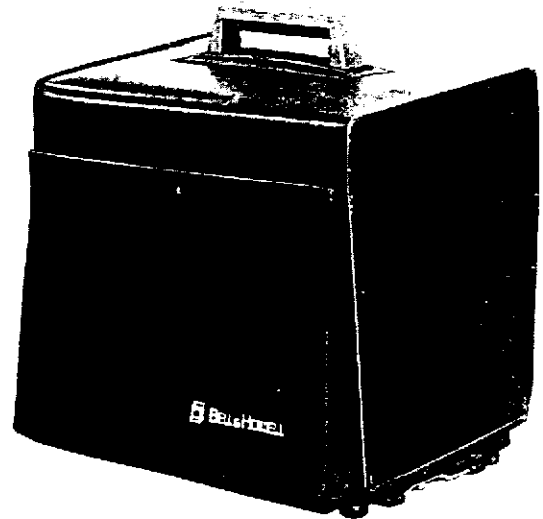
**ORCHESTRICON™ III SPEAKER**

Bell & Howell Part No. 077799

This 12" (30cm) accessory speaker provides the ultimate in extension sound. Complete with 50' (11m) of cord.

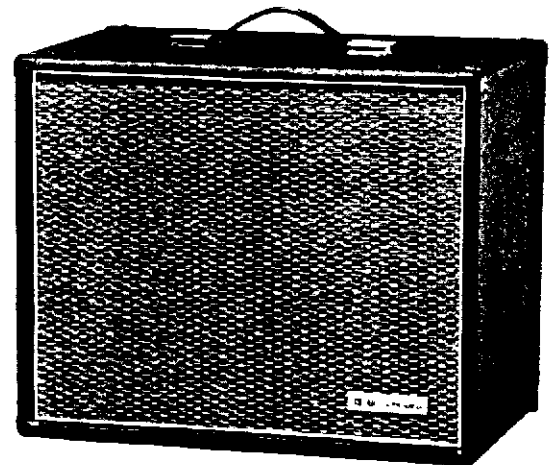
**DIRECTAMOTION® REMOTE CONTROL (not shown)**

Bell & Howell Part No. 014128

(For Model 2592 only)

Allows the operation of the Directamotion feature from a distance. Plugs into the socket on the rear of the projector.

SPEAKER COVER

Bell & Howell Part No. 078146

This convenient extension speaker doubles as the projector's cover for maximum portability and storage convenience.

Complete with 35' (10.6m) self-storing cord.

HOUR METER (not shown)

Bell & Howell Part No. 078826

This instrument is used to accurately measure projector utilization, lamp longevity, and projector performance. Helps in the scheduling of regular projector maintenance based on hours of use. Installed by service station only.

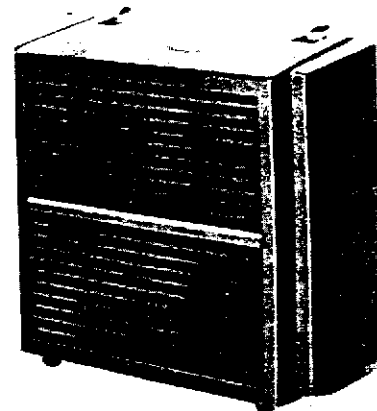

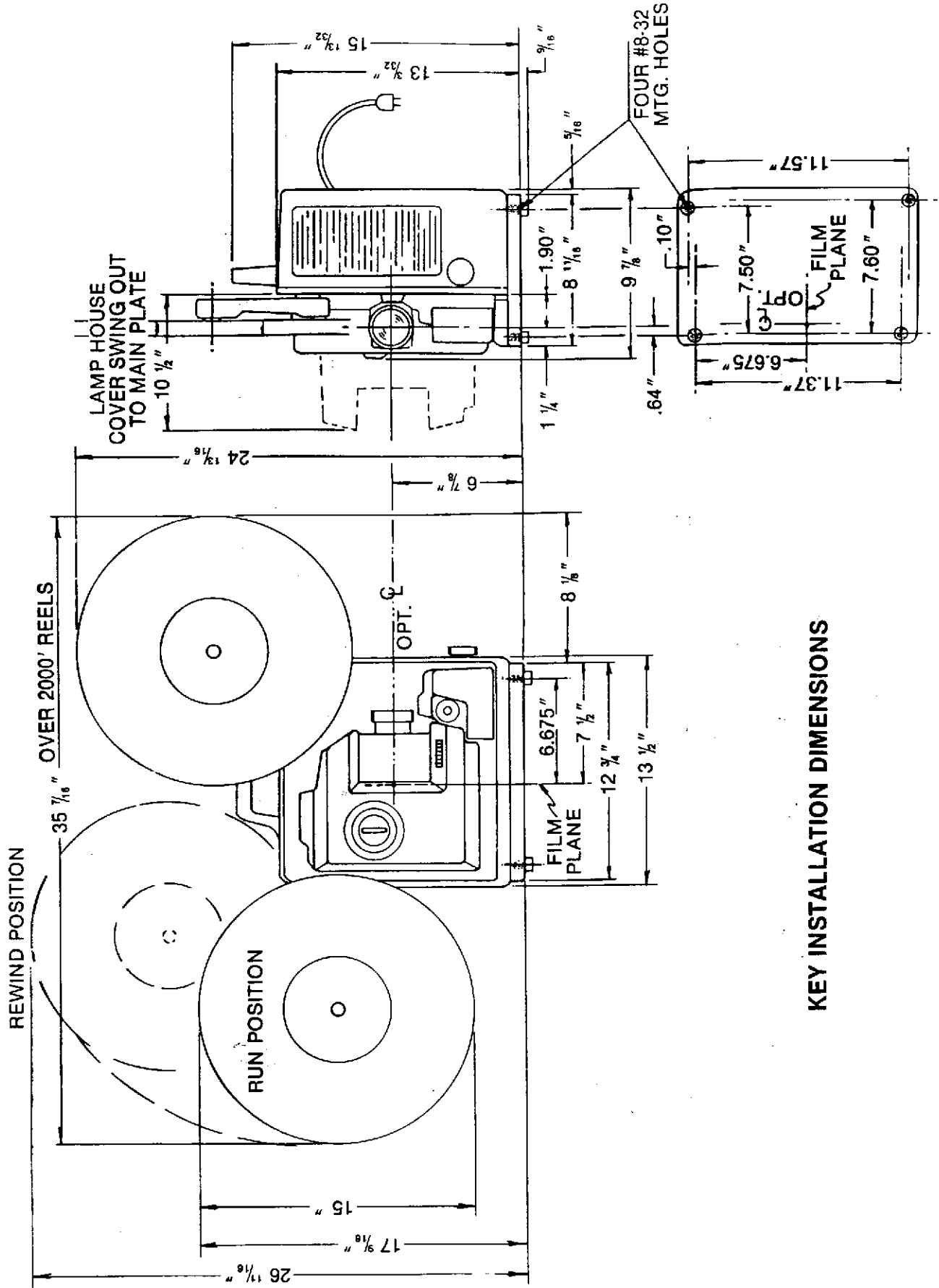

KEY INSTALLATION DIMENSIONS

Bell & Howell Limited Warranty

This Bell & Howell equipment is warranted to be free from defects in both materials and workmanship. Should any part of this equipment be defective, it will be repaired or replaced, at Bell & Howell's option, free of charge (except incoming shipping charges) for a period of **one (1) year** from the date of original purchase. No charge will be made for parts or labor during this period.

Notice: Your sales receipt is your warranty validation. Dated proof of purchase (such as bill of sale or cancelled check) must be provided when requesting warranty work to be performed.

This warranty is void if:

(a) the equipment has been damaged by negligence, accident or mishandling, or has not been operated in accordance with the procedures described in the operating instructions; or

(b) the equipment has been altered or repaired by other than a Bell & Howell approved service station or one of the following factory service centers (approved service station list will be made available upon request), or adaptations or accessories other than Bell & Howell's have been made or attached to the equipment which, in the determination of Bell & Howell, shall have affected the performance, safety, or reliability of the equipment.

(c) The equipment's original serial/data plate has been modified or removed.

NO OTHER WARRANTY EXPRESSED OR IMPLIED, INCLUDING MERCHANTABILITY, APPLIES to the equipment, nor is any person or company authorized to assume any other warranty for Bell & Howell. **BELL & HOWELL DOES NOT ASSUME ANY RESPONSIBILITY FOR ANY CONSEQUENTIAL DAMAGES**, including unsatisfactory or damaged film, inconvenience or interruption in operation. Bell & Howell warranty service is limited to the duration of the warranty period.

Some states do not allow limitations on how long an implied warranty lasts or the exclusion or limitation of incidental or consequential damages, so the above limitations or exclusions may not apply to you.

This warranty gives you specific legal rights, and you may have other rights which vary from state to state.

In case of unsatisfactory operation, the equipment should be sent directly (or through a Bell & Howell authorized dealer) to a Bell & Howell approved service station or one of the factory service centers listed within this catalog, with a description of the problem. Please do not include personal material with the returned equipment as Bell & Howell does not accept responsibility for these items.

Bell & Howell Visual Communications Group

Audio Visual Products, 7100 North McCormick Road, Chicago, IL 60645 (312) 673-3300

Specifications subject to change without notice.

©1984 Bell & Howell Company. All Rights Reserved.