

FILM-TECH

THE INFORMATION CONTAINED IN THIS ADOBE ACROBAT PDF FILE IS PROVIDED AT YOUR OWN RISK AND GOOD JUDGMENT.

THESE MANUALS ARE DESIGNED TO FACILITATE THE EXCHANGE OF INFORMATION RELATED TO CINEMA PROJECTION AND FILM HANDLING, WITH NO WARRANTIES NOR OBLIGATIONS FROM THE AUTHORS, FOR QUALIFIED FIELD SERVICE ENGINEERS.

IF YOU ARE NOT A QUALIFIED TECHNICIAN, PLEASE MAKE NO ADJUSTMENTS TO ANYTHING YOU MAY READ ABOUT IN THESE ADOBE MANUAL DOWNLOADS.

WWW.FILM-TECH.COM

TQ III 16mm Projectors

Design 1692/1693/1694/1695/1698

Service Manual

Part Number 2307881

 **BELL & HOWELL**

Contents

INTRODUCTION, PAGE 1

R SIMPLE REPLACEMENTS, PAGE 2

RA	Lamps
RA1	" PROJECTOR
RA2	" EXCITER
RB	Magnetic Heads
RC	Fuses
RC1	" MAIN
RC2	" SECONDARY
RD	Drive Belts
RD1	" MOTOR DRIVE
RD2	" TAKE-UP DRIVE

M MECHANICAL, PAGES 2 - 14

MA	Covers
MA1	" REAR
MA2	" TOP
MA3	" REAR END PLATE
MA4	" FRONT END PLATE
MA5	" EXCITER LAMP
MA6	" MAIN ACCESS
MA7	" AMPLIFIER, VOL/TONE CONTROLS
MB	Transformer
MC	Fuse/Diode Panel
MD	Projector Motor
ME	Motor Servo I/C
MF	Speed Control Panel
MG	Fire Shutter Solenoid
MH	Clutch Solenoid
MI	Sound Head
MJ	Lamp: Shield and Holder
MK	Mechanism
MK1	" REMOVAL
MK2	" REPLACEMENT
MK3	" DISASSEMBLY
MK3.1	" " lens carrier
MK3.2	" " general
MK3.3	" " aperture plate
MK4	" REASSEMBLY
MK4.1	" " aperture plate
MK4.2	" " clutch and camshaft
MK4.3	" " shuttle and cam
MK4.4	" " heat baffle
MK4.5	" " cam follower
MK4.6	" " kickplate & loop former
MK4.7	" " shuttle retractor
MK4.8	" " auto-thread lever
MK4.9	" " lens carrier
MK4.10	" " sprocket assemblies
ML	Animation Switch Assembly
MM	Main Function Switch: Rotary

MN	Still/Run Switch
MO	Loudspeaker
MP	Reel Arm: Front
MQ	Reel Arm: Rear
MR	Blower Assembly

A ADJUSTMENTS, PAGES 14 - 22

A1	Optical Alignment
A1.1	" " aperture plate
A1.2	" " lamp socket
A2	Intermittent Assembly
A3	Film Transport
A3.1	" " loop restorer
A3.2	" " sprocket timing
A3.3	" " shuttle retractor
A3.4	" " animation clutch
A3.5	" " fire shutter
A3.6	" " auto-thread system generally
A3.7	" " lens carrier
A3.8	" " reel arms & rewind clutch
A3.9	" " gear shift tension
A3.10	" " idler gear
A4	SOUND HEAD: OPTICAL
A4.1	" " " roller tension
A4.2	" " " positioning
A4.3	" " " optical slit
A4.4	" " " buzz track
A5	SOUND HEAD: MAGNETIC
A5.1	" " " head wear
A5.2	" " " tracking
A5.3	" " " 1/2 track heads
A6	EXCITER COVER
A7	MOTOR: SPEED ADJUSTMENTS
A8	WARNING LAMP: ADJUSTMENT

TOOLS & TEST EQUIPMENT, PAGES 23 - 28

LUBRICATION CHART, PAGE 29

TROUBLES & REMEDIES, FROM PAGE 30

DIAGRAMS & DRAWINGS

Stages of disassembly, page 3
Disassembly/Assembly, pictures A-S, facing page 6
Disassembly/Assembly, pictures T - Z12, facing page 14
Motor speed adjustment, picture U, page 21
Warning lamp adjustment, page 22
Adjustments, pictures A - W, facing page 22
Mechanism testing bracket, page 28

For mechanical and electrical parts, part numbers and diagrams, refer to separate parts catalogue (P/N 2307882).

Introduction

This manual describes servicing procedures for the whole TQIII range of 16mm sound projectors: Models 1692, 1693, 1694, 1695 and 1698.

In the text, references are made to two kinds of illustration or diagram. Those prefixed "Picture" will be found on the fold-out sheets following the Assembly and Adjustments sections of this manual. Those prefixed "Fig" are in the separate Parts Catalogue.

In the Parts Catalogue, "item" numbers are used to identify components in the illustrations. Please note that these numbers are not necessarily the same as those used in Service Bulletins you have already received and that they are not part numbers. It is essential that orders for parts quote the five- or six-digit numbers given in the parts lists and not on the drawings

CLEANING

All the film path areas must be kept free from accumulations of film emulsion, otherwise film may be scratched or may jam during automatic threading. When removing emulsion, be careful not to scratch the surfaces. Pay particular attention to the sound head cover around the sound head.

Do not use trichlorethylene solvents to clean plastic parts. Use a naphtha-base cleaning fluid and be sure that grease is not wiped off areas that need lubrication. Do not use solvents on these critical areas, especially in the auto-threading linkage; lubrication is applied during assembly and it is difficult to replace without disassembling the linkage. Use a soft lint-free cloth when necessary to remove any accumulation of dust or film chips.

During periodic maintenance of the projector, the transport mechanism should be removed and thoroughly cleaned. Brush or blow out all large particles of dirt. Wash all moving parts, except pre-lubricated bearings, with any good petroleum solvent. Wash pre-lubricated bearings and the pull-down cams with naphtha. Discard and replace the cam wiper and cam wiper wick. As soon as parts have been washed and dried, coat with a light film of the specified lubricant.

The removal and installation of most projector parts can be accomplished with tools normally available in repair shops. A pencil-type soldering gun should be available for electrical repairs and the Bristol wrenches listed in the section on Service Information and Tools will also be required. Special tools necessary for projector alignments and adjustments are illustrated and listed in this section.

LUBRICATION

Before reassembly, unless otherwise specified, apply one or two drops of oil (Shell Clavus No. 27) to all shafts, sleeve bearings and sliding parts. Certain parts require different lubricants and it is important to use only those specified in the Lubrication Chart, which is situated in the Service Information & Tools section. Do not overlubricate. Apply oil and grease sparingly and remove excess with lint-free cloth. Felt pads or wicks must be placed in a shallow container of the specified lubricant with one-half of the pad or wick exposed. After felt is saturated, allow excess oil to drain off before installation.

R Simple Replacements

the fuse/rectifier panel which is mounted on the motor brackets. See Fuse Table in Parts List for values.

RA. LAMPS

RA1. PROJECTOR LAMP

The high efficiency of the dichroic reflector that surrounds the projector lamp depends on a surface coating which is extremely delicate. In no circumstances should either the reflector coating or the quartz envelope be touched with bare hands. When holding the lamp, use cotton gloves or clean white tissue paper. If the surfaces are accidentally touched, they should be thoroughly cleaned with a grease solvent such as industrial alcohol.

RA1.1. To replace projector lamp

Open the main access door.

Release the lamp retaining spring.

Fit new lamp.

Replace lamp retaining spring.

Close the main access door.

RA2. TO REPLACE EXCITER LAMP

Open the main access door.

Remove exciter lamp cover by releasing the single retaining screw.

Press exciter lamp release lever towards the projector (Picture A).

Rotate lamp anticlockwise until circular holes in its flange coincide with the three bayonet pins.

Lift lamp from socket.

Rotate the new lamp until the circular holes in its flange are seated on the three bayonet pins. Continue rotating gently in a clockwise direction until the flange locks into position.

Pull exciter lamp release lever away from the projector to secure the lamp.

Replace exciter cover.

RB. MAGNETIC HEADS

RB1. REPLACING MAGNETIC HEADS

Remove exciter lamp cover and selector knob.

Press head assembly and rotate anticlockwise to release it from mounting shaft.

Fit new assembly by engaging it on shaft. Press and rotate clockwise until it seats into position.

RC. FUSES

RC1. MAIN FUSE

The main fuse is located on the panel inside the cord storage compartment. The fuse can be removed by rotating the fuseholder cap by means of a screwdriver or thin coin.

RC2. SECONDARY FUSES

Five additional fuses (four on Models 1692 and 1693) are employed to protect individual low-voltage circuits. These are located on

RD. DRIVE BELTS

RD1. REPLACING MOTOR DRIVE BELT

Remove rear cover (MA1) and take out faulty belt.

Seat new belt on knurled section of motor pulley.

Engage top section of belt with face of mechanism drive pulley.

Rotate inching knob anticlockwise and guide belt until it fully engages pulley (avoid damage to shutter blades during this operation). Ensure that belt is still seated on knurled section of motor pulley.

Check operation before replacing rear cover.

RD2. REPLACING TAKE-UP DRIVE BELT

Remove two screws to release spool arm front cover (do not loosen coiled tension spring).

Remove belt from pulley gear assembly.

Check condition of capstan; if greasy, clean with industrial alcohol.

Fit new belt.

Replace front cover and ensure that coiled tension spring is correctly seated (Picture B).

M Mechanical

MA. COVERS

MA1. REMOVING REAR COVER ASSEMBLY

Remove a total of seven screws X (Picture C). Cover can now be withdrawn to extent of cable harness.

Note. For better access, the back cover can be completely released by removing

four screws Y (Picture C) from socket mounting. Pass mounting through rectangular hole in back cover.

MA2. REMOVING TOP PLATE

Remove two hexagon head screws X (Picture E).

MA3. REMOVING REAR END PLATE

Remove one screw X (Picture F).

Remove two hexagon head screws X (Picture G) on base plate.

MA4. REMOVING FRONT END PLATE

Remove two hexagon head screws X (Picture H) and hexagon head screw (Picture I) on base plate. Remove inching knob by loosening a Bristol screw.

STAGES OF DISASSEMBLY

Refer to this diagram before starting to disassemble. By beginning at the top of the diagram and working downwards to the area needing attention, you may save yourself unnecessary work.

The chart shows, for example, that to remove the solenoid fire shutter you must first remove, in this order, the speed control and mains input panel, the rear cover, the top cover, the fuse panel and then the motor. But the chart also shows that to remove the animation switch, only the first three of these steps need be taken; the mains panel, the rear cover and the top cover. Alpha-numeric references in the boxes (eg MK1) refer to the section of the manual which gives full instructions.

For details of manual mechanism (1694M), see also Model 1644 in TO11 Service Manual.

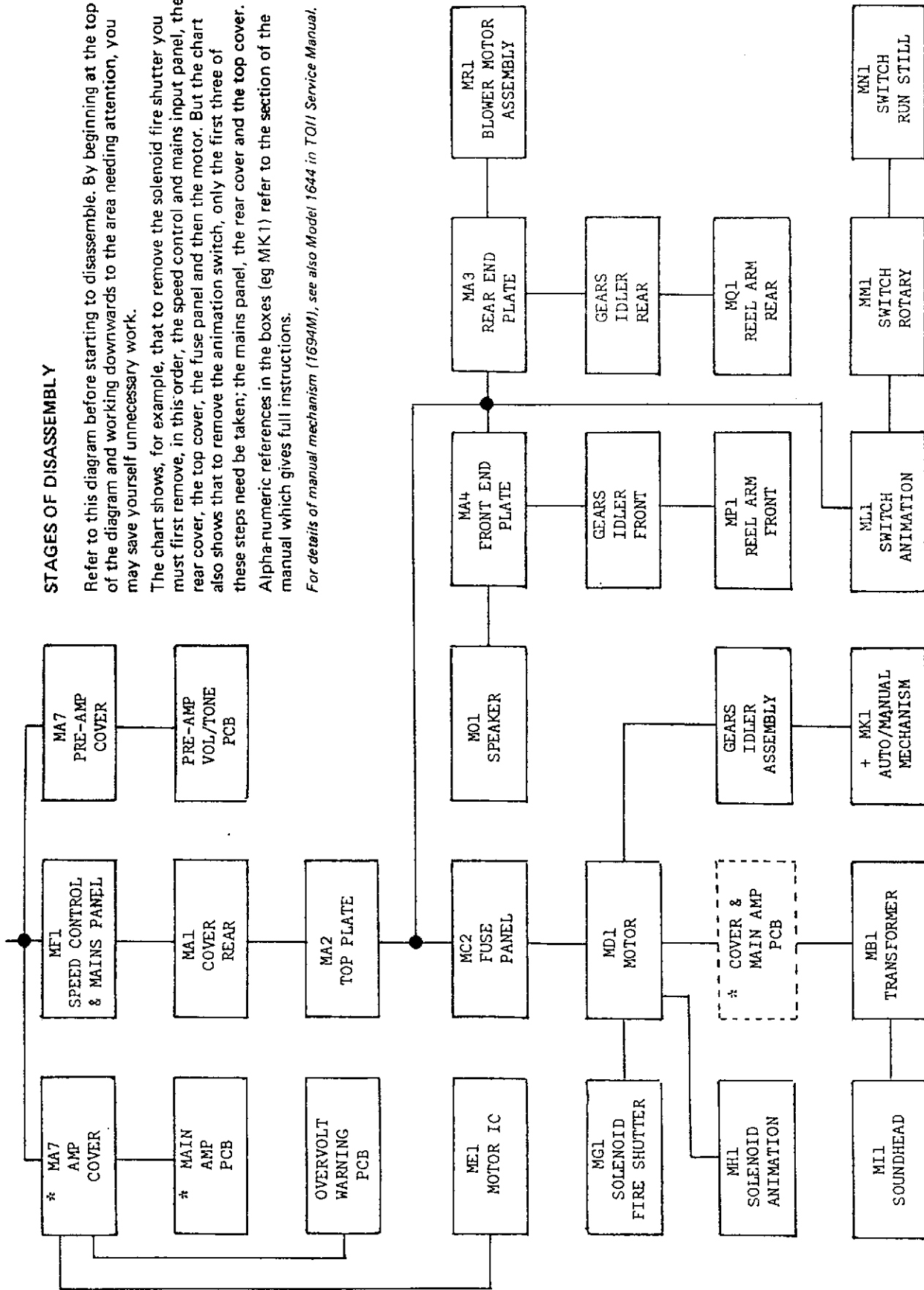

MA5. REMOVING EXCITER LAMP COVER
Unscrew knurled retainer and remove cover.

MA6. REMOVING MAIN ACCESS DOOR

Open door and remove three hexagon screws (Picture J).

MA7. REMOVING VOLUME/TONE AND MAIN AMPLIFIER COVERS

Remove four screws to release cover for volume/tone control PCB, and also remove five screws securing main amplifier cover to the base plate (Picture K).

MB. TRANSFORMER

(For electrical details see projector wiring diagram)

MB1. TO REMOVE TRANSFORMER

Remove rear cover (MA1) and top plate (MA2).
Unplug multi-pole connectors.

Remove connectors from tags 19/20/21.

Stand projector on rear end plate.

Remove main amplifier cover (Picture K).

Remove main amplifier PCB.

Support transformer and remove four screws X (Picture L).

MB2. TO REPLACE TRANSFORMER

Reverse removal procedure (MB1). For electrical connections see projector wiring diagram.

MC. FUSE/DIODE PANEL (FUSE BOARD ASSEMBLY)

(For electrical details see projector wiring diagram)

MC1. ACCESS TO FUSES AND TEST POINTS

Remove rear cover (MA1).

MC2. REMOVAL OF PANEL

Remove both fuse panel screws and unsolder all wiring. For electrical connections, see projector wiring diagram.

MD. MOTOR

(For electrical details see projector wiring diagram. For adjustment details see A7).

MD1. TO REMOVE MOTOR

Remove rear cover (MA1) and top cover (MA2).

Remove drive belt.

Remove left-hand screw from fuse panel (MC1).

Unplug motor connector and release wiring harness from retainer on left-hand motor bracket.

Remove earth tags from motor brackets.

Release left-hand motor bracket by removing two hexagon head screws.

Remove motor from resilient mountings.

MD2. TO REPLACE MOTOR

Reverse removal procedure. Ensure that locating dowels in resilient mountings are seated through corresponding holes in motor brackets.

Check FPS speeds and adjust if necessary (A7).

ME. MOTOR SERVO INTEGRATED CIRCUIT

(For electrical details see projector wiring diagram)

ME1. TO REMOVE INTEGRATED CIRCUIT (MOTOR SPEED CONTROL)

Stand projector on rear end plate.

Remove main amplifier cover (MA7).

Remove IC connector socket.

Remove two screws X (Picture M).

ME2. TO REPLACE INTEGRATED CIRCUIT

Reverse removal procedure.

Check FPS speeds and adjust if necessary (A7).

MF. SPEED CONTROL PANEL

(For electrical details see projector wiring diagram. For adjustment details see A7)

MF1. TO REMOVE PANEL

Remove rear cover or power socket mounting panel.

Release speed control panel by removing two retaining screws.

MF2. TO REPLACE PANEL

Reverse removal procedure (MF1). For electrical connections see projector wiring diagram.

Check FPS speeds and adjust if necessary (A7).

MG. SOLENOID : FIRE SHUTTER (1694, 1695, 1698)

(For electrical details see projector wiring diagram. For adjustment details see (A3.5).

MG1. TO REMOVE SOLENOID

Remove fuse panel (MC2) and motor (MD1).

Release solenoid by removing two retaining screws X (Picture N).

Remove push-on connectors.

MG2. TO REPLACE SOLENOID

Reverse removal procedure (MG1).

Adjust as necessary (A3.5).

MH. SOLENOID : CLUTCH

(For electrical details see projector wiring diagram. For adjustment details see (A3.4).

MH1. TO REMOVE SOLENOID

Remove fuse panel (MC2) and motor (MD1).

Remove main amplifier cover.

Remove main amplifier PCB.

Remove two retaining screws X (Picture O) and slide solenoid to rear of base to disengage plunger. Do not bend still-run rod.

Observe position of plastic base strip.
Remove push-on connectors.

MH2. TO REPLACE SOLENOID

Reverse removal procedure (MH1), ensuring that plastic base strip is in correct position and that locating dowel on solenoid is seated in projector base.
Adjust if necessary (A3.4).

MI. SOUND HEAD

(For electrical details see projector wiring diagram. For adjustment details see A4 and A5).

MI1. TO REMOVE SOUND-HEAD ASSEMBLY

Remove fuse board (MC2).

Remove motor (MD1).

Remove transformer (MB1).

Remove sound-head flywheel by releasing retaining ring and washer (Pic Q). Note position and number of plain and tension washers on shaft.

Remove exciter lamp. Wrap and store safely.

Remove volume/tone cover (MA7).

Unsolder or disconnect wiring and remove PCB as necessary.

Release by removing all push-on connectors.

With sharp pencil, draw a line on the projector main plate along the front edge of the sound-head casting. This will provide a guide reference for locating the sound head during installation (Picture R).

Engage the auto-thread system.

Remove the three assembly retaining screws X (Picture S) and carefully withdraw the sound-head assembly from the projector main plate, allowing the wiring to pass through the apertures in the castings.

Use a heat sink when unsoldering the lead from the centre terminal of the exciter lamp socket.

MI2. TO REPLACE SOUND-HEAD ASSEMBLY

Engage the auto-thread system.

Reverse removal procedure (MI1).

For electrical connections, see relevant projector wiring diagram. For sound-head positioning and adjustments, see A4 and A5.

MI3. DIASSEMBLING SOUND-HEAD ASSEMBLY

Remove sound-head assembly (MI1).

Disassemble as required for access to following parts:-

MI3.1. Replacing photocell wiring board assembly

(Models 1692, 1695, Fig 13. Models 1693, 1694, 1698, Fig 14)

Loosen setscrew 37 (Picture T) and withdraw photocell assembly. Do not lose plastic retainer 43.

Slide new photocell assembly into position. If optical slit assembly has not been removed, insert photocell assembly and plastic retainer from rear as shown in Picture U. If optical slit has been removed, insert photocell from rear and plastic retainer from front as shown in Picture V.

Align the leading edge of the new photocell with the inner edge of the sound drum (Picture W) and tighten screw 37.

MI3.2. Optical slit assembly

(Models 1692, 1695, Fig 13. Models 1693, 1694, 1698, Fig 14)

For adjustment details see Picture W and A4.3.

Do not disturb this optic unless replacement or adjustments are required.

Loosen clamping screw 34 to remove the assembly. If the assembly does not slide freely in holder, insert blade of a small screwdriver into clamp slot and ease it open to free the assembly. If necessary, clean front and rear lens surfaces, using lens tissues in conjunction with orange stick.

When replacing assembly, ensure that one of the two adjusting holes in rear of barrel is in a vertical position. For adjustment details see A4.3.

MI3.3. Sound-drum assembly

(Models 1693, 1695, Fig 13. Models 1693, 1694, 1698, Fig 14)

To release sound-drum assembly, remove photocell (MI3.1). It is unnecessary to unsolder cell leads to carry out this operation. Remove two retaining screws 39 and do not lose shakeproof washers 40. Withdraw complete assembly.

Fit replacement assembly by reversing above procedure.

To position the sound-drum assembly, remove the optical slit assembly (MI3.2). Insert the sound-drum alignment gauge into the optical slit opening as shown in Picture X. Press the sound drum in until its inner face just makes contact with the first step or bearing surface of the gauge Y (Picture X) and maintain this contact while tightening the two screws 39 securely. Withdraw the alignment gauge and align the leading edge of the photocell as described in MI3.1.

Replace optical slit assembly and realign (A4.3).

MI3.4. Replacing contact and exciter lamp release

(Models 1692, 1695, Fig 13. Models 1693, 1694, 1698, Fig 14)

Release assembly by removing two screws 34. Replace parts as necessary. When reassembling, smear a small quantity of grease between lamp release and nylon surface.

MI3.5. Stabilizer assembly

(Models 1692, 1695, Fig 13. Models 1693, 1694, 1698, Fig 14).

To remove stabilizer assembly, release all springs and remove retaining ring 25. Do not lose tension washer.

Replace parts as necessary.

Adjust as necessary (see A4.1).

MI3.6. Replacing sound head switch

(Models 1693, 1694, 1698, Fig 14)

Pull off control knob. Remove magnetic head assembly by pressing it forward and rotating anticlockwise until released.

Remove spring 59, two screws 17 and 18 (do not loosen screw 15 for this operation), and latch assembly 19.

Loosen set screw 51 and release cam 52, using Bristol key S-072. Release hexagon nut and withdraw switch.

Fit new switch by reversing above procedure. Install spring 59 with long hooked end connected to latch assembly 19.

Check free movement of magnetic head and positive engagement of head contacts.

MJ3.7. Replacing contact block assembly

(Models 1693, 1694, 1698, Fig 14)

Remove the two screws retaining the block (do not disturb the guide bracket screws).

If bracket requires replacement due to damage, note position or carefully mark location before removal.

MJ. LAMP SHIELD AND LAMP HOLDER ASSEMBLY

(For electrical details see projector wiring diagram. For adjustment details see A1.2)

MJ1 TO REMOVE ASSEMBLY

Remove main access door (MA6).

Remove lamp; wrap and store safely.

Release lampholder and shield by removing three screws X (Picture Y) and push-on connectors.

MJ2. TO REPLACE ASSEMBLY

Reverse removal procedure MJ1.

Check alignment (see A1.2).

MK. MECHANISM

MK1. TO REMOVE MECHANISM ASSEMBLY

(For adjustment details, see A2 and A3)

Remove:-

Fuse panel (MC)

Motor (MD1)

Projection lens

Exciter lamp cover (MA5)

Main access door (MA6)

Lampholder assembly (MJ1)

Set auto-thread system to "load" position.

Release snubber lever spring (Picture Z1) and remove gears X (Picture Z2), noting position of spacer washers where fitted.

Unlatch spring assembly X (Picture Z3).

Remove idler arm and rewind gear (Picture Z3).

Where fitted, remove animation lever, pulling and turning switch actuating crank to downward position (Picture Z4).

Remove snubber guide assembly (Picture Z5).

Remove two top mechanism retaining screws X (Picture Z6) and release idler gear adjusting bracket.

Remove lower right-hand mechanism retaining screw Y (Picture Z6).

(Note: Lower left-hand retaining screw Z (Picture Z6) can be removed without disassembling additional parts if tool shown in Picture Z6 is used.)

Tilt mechanism to disengage solenoid plungers. Carefully avoiding damage to sound drum,

release mechanism from snubber film guide and withdraw from faceplate.

MK2. TO REPLACE MECHANISM ASSEMBLY

Reverse remove procedure, carefully avoiding damage to sound drum and lower film guides and ensuring that all spacer washers and gear retainers are installed in correct positions.

Carry out external adjustments as necessary (see A3.4, A3.5, A3.9, A3.10, A4.2).

MK3. DISASSEMBLING MECHANISM

(Refer to Fig 15)

Remove parts as necessary, in the following order of disassembly.

MK3.1. Lens Carrier Assembly

To remove lens carrier assembly 5, pry out the hinge pins 1 with pliers or a similar tool and lift the lens carrier from the mechanism (it may be necessary to replace pins if they are damaged during removal). Note that the spring washer 3 is used with the upper pin and the flat washer 4 with the lower pin.

To disassemble the lens carrier, remove two screws 6, the pressure plate 7, springs 8, pressure plate lever 9 and washers 10. The adjustment plate 12 need not be removed.

Carefully pry the nameplate with a knife blade. Remove two screws 11. Disassemble the spring 14 and the knob and pinion assembly 15 from the lens carrier 16.

MK3.2. Mechanism

Remove the retaining ring 21 and withdraw the actuating lever 22. Remove the two screws 23 and the hood 24.

Loosen two set screws 39 and 25 in sprocket gears 40 and 26 and remove bottom gear 26.

Remove spring tension washers 52 and 58 from the sprocket shaft 41.

Remove the two screws 28 and the upper sprocket guard assembly 29.

(Fig 16) Remove screws 1 and rollers 2 from guard mounting plate assemblies, upper 42 and lower 22.

Remove (Fig 15) sprocket shaft assembly upper 37, thrust washer 38, gear 40, spring tension washer 27, sprocket shaft assembly lower 41, flange sprocket 42 and thrust washer 43.

When removing sprocket guards 48, note how the tension springs 50 are assembled so that they can be correctly reinstalled.

Remove screws 47, sprocket guards 48, rollers 49 and springs 50.

Remove retaining ring 44 from the lower end of the rewind button shaft, lift the rewind button 45 and its spring 46 from the top of the mechanism housing.

(Note how tensions springs 5, 10 and 14 are installed (Fig 16).

Remove circlip 3, threading arm 4 and tension spring 5 from the lower guard mounting plate assembly 22.

Remove the retaining ring 12, lift off the lower loop former 13 and the tension spring 14.

Remove screw 6, idler roller 7, spring 10, stud 8, locking lever eccentric bush 9 and auto-thread lever assembly 11.

If necessary, dismantle assembly 11 as follows:-

Remove screw 80, film guide 81, screw 82, film guide 84, washer 87, idler roller 83 and snubber spring 85.

Remove screw 15 and back-up bracket 16.

Remove screw 78, film exit guide 79, retaining ring 17, lower film guide 19 and two washers 18.

Remove two screws 15, the lower film guard mounting plate 22, lower film guide 25, retaining ring 20, toggle and lever pivot assembly 24.

Disengage spring 45, loosen two screws 43, remove upper loop former shaft 44. Loosen screw 28 and remove threading assembly lever 29.

Remove retaining ring 30, upper loop former assembly 31 and connecting link and stud assembly 36.

(The hex screw 37 is used to adjust the lens carrier and should not be disturbed. Do not remove the lens carrier catch 39 unless damaged and in need of replacement.)

Remove two screws 41, the upper guard mounting plate 42, the upper loop former and kickplate assembly 47 and washer 46.

Do not disassemble the loop former and kickplate assembly 47 unless parts are damaged and in need of replacement.

Disengage the free end of spring 57. Remove the screw 55 and flat washer 56. Remove the screw 58 and flat washer 59 and lift off the cam follower and support assembly 60. (Do not disassemble the latter unless parts are damaged and in need of replacement.)

Loosen the hex head locking screw 67 and disassemble the arm assembly 68, flat washer 69, and the lever and shaft assembly 70 from the mechanism housing.

Remove the two screws 72, lock washers 73 and flat washers 74, which secure the self-centering assembly 75 to the mechanism housing (the self-centering device is supplied only as a complete assembly).

Remove screws 76 and the aperture plate assembly 77.

For aperture disassembly, see MK3.3.

(Models 1692, 1693, Fig 17. Models 1694, 1695, 1698, Fig 18)

Loosen two set screws 3 and withdraw the mechanism pulley 4 from the end of the camshaft. Remove four screws 1.

Lift off the fire shutter assembly 2. Inspect the fire shutter parts (Fig 20) and replace if damaged.

Remove two screws 5, heat baffle 6, two spacers 7 and heat baffle 8. Remove the shutter nut 9, counterbalance weight 10, shutter 11 and fibre washer 12.

Unless they are obviously in need of replacement, do not disassemble the ball and stud assemblies 14 or the shuttle link bearings 20 from the shuttle arms 19.

Inspect the pull-down cam followers 21 for wear. These followers are staked in place in the recess of each shuttle arm and can be reversed or turned end-for-end if badly worn.

Unhook the extension spring 15 from the end of each shuttle arm. The cam wiper wick 17 is inserted within the coils of

this spring. If the wick appears very dirty, replace it.

If it is necessary to remove the shuttle mechanism, withdraw pull-down cam 22 from the camshaft. Remove shuttle 18, withdraw shuttle arm and bearing assembly from in-out cam bracket. Remove felt wiper 16 and replace if dirty.

To remove ball and stud assemblies 14, slacken hexagon nuts 13, remove two screws 23, washers 24, in-out cam bracket assembly 26 and in-out cam 25.

Inspect the cam follower 27 and spring 28 and replace if damaged.

Remove two screws 29 and the shuttle arm plate assembly 30. Remove screw 34, in-out spring 35 and cam retractor pin 36.

Punch out the stop pin 32 and unscrew the framer knob and shaft 33 from the mechanism housing.

(Models 1694, 1695, 1698, Fig 18)

Remove two screws 44 and stop pawl shaft bracket 45. Inspect the grommets 46 and, if damaged, press them out of the bracket 45 and replace them.

Remove two retaining rings 37 and spring 39. Remove shaft 38, stop pawl 40, two screws 41, washers 47, clutch stop 42 and bearing bracket 43.

(Models 1694, 1695, 1698, Fig 19)

Remove, as necessary, the round nut 1 and washer 2. Disassemble the shuttle adjustment bracket 3 from the animation clutch bracket assembly 7. Remove the screws 4 and 5, lock washers 6 and lift the animation clutch bracket assembly 7 from the mechanism housing.

If bracket assembly parts are in need of replacement, remove the three retaining rings 10 and slide the shaft 11 from the clutch housing bracket 19, removing the slide bumper 12, washer 13, spring 14 and clutch bar assembly 15 from the shaft as it is withdrawn. Remove the screw 16 and washer 17 to free the striker 18 from the clutch slide bar.

Loosen screw 25 and remove inching knob 26. Remove the large retaining ring 24, the two screws 27 and the bearing loading spring 28. Loosen the set screw 29 in the loop restorer cam 49 and press the camshaft 52 to the left until the bearing 30 is forced from the mechanism housing. Pull the bearing from the camshaft.

Remove retaining rings 34 and 50 from the camshaft and press the shaft to the right to force the large bearing 51 from its seat.

Remove the clutch gear and cam parts 31 to 42 and 47 to 49 as the camshaft is withdrawn (Note how the tension spring 32 is assembled

Inspect worm gear parts 43 to 45 and, if damaged, disassemble for replacement.

Models 1692/1693 (Fig 17). Continue disassembly as follows:-

Loosen screw 48 and remove inching knob 49. Remove the large retaining ring 61, two screws 50 and the bearing loading spring 51.

Loosen screw 57 in the loop restorer cam 58 and press the camshaft 62 to the left until bearing 52 is forced from the mechanism housing. Pull the bearing from the camshaft.

Remove retaining ring 59 from the

camshaft and press the shaft to the right to force the large bearing 60 from its seat.

Loosen set screws 55, remove worm gear assembly 56 and the loop restorer cam 58. Examine the worm gear and replace it if damaged.

MK3.3. Aperture Plate : Disassembly

Remove parts as necessary, in their indexed order (Fig 21).

Avoid scratching or otherwise damaging the rails or other parts which come into contact with the film.

MK4. REASSEMBLING THE MECHANISM

MK4.1. Reassembling the aperture plate (Fig 21)

Avoid scratching or otherwise damaging the rails or other parts which come into contact with the film.

MK4.1.1. Assemble the film guide to the aperture plate 12 with the screw 9. The right-hand edge of the film guide 10 should be square with the edge of the aperture plate.

MK4.1.2. Assemble the side tension spring 8 and the film tension rail 7 to the aperture plate 12. The ends of the spring should engage in notches in the film tension rail and the centre of the spring should bear against the staked pin in the aperture plate. Assemble the spacer bushing 6 and spring retaining cover 5 to the aperture plate 12 and install two screws 4. Attach the heat baffle 2, using screws 1 which pass through the aperture plate 12 and into side guide 3; tighten these screws securely.

MK4.2. Reassembling clutch and camshaft

MK4.2.1. Models 1694, 1695, 1698 (Fig 19)

Assemble the striker 18 to the clutch bar assembly 15 with the screw 16 and washer 17.

Insert the shaft 11 part way through the right-hand arm of the mounting bracket assembly 19 and install the bumper 12 on the end of the shaft. Hold the slide bar assembly 15 in position between the arms of the bracket assembly and continue to insert the shaft, assembling the flat washer 13 and spring 14 on the shaft before it is inserted through the left-hand arm.

Install the three retaining rings 10 with the centre ring to the right of the spring and washer.

The set screw 8 must be adjusted at final assembly to limit slide bar travel (see A3.3).

Assemble the complete clutch bar assembly 7 to the mechanism housing with two screws 4 and 5 and lock washers 6. Press down firmly on the bracket while tightening the screws.

Assemble the adjustment bracket 3 to the end of the longer screw 5 and install the washer 2 and round nut 1.

Tighten the nut finger tight (see A3.3).

Lightly grease both bearing openings in the cast arm of the mechanism housing. Press the ball race 30 into its seating. Assemble the large bearing 51 to the camshaft 52 until the bearing is seated against the shoulder of the shaft. Install the retaining ring 50 to the camshaft with the bowed surface of the ring away from the bearing.

Assemble the three rubber bushings 47 into the corresponding openings in the face of the worm gear assembly 42. Present the bearing assembly 41 to the worm gear so that the forward ears of the bearings are aligned with corresponding notches in the worm gear.

Insert the bent ears of the clutch yoke 39 through the slots in the bearing assembly, while assembling the spring 40 over the protruding finger of the clutch yoke and into the hole in the bearing assembly. Hold these parts together while assembling the two shoulder pins 38 to the bearing assembly, pressing them in until they engage the bent ears of the clutch yoke.

Assemble the trigger 37 to the sleeve bearing 36 and press the bearing through the bearing assembly 41 and into the worm gear.

Insert the end of the camshaft 52, with ball race 51 assembled, through the bearing hole in the right-hand cast arm of the mechanism housing. To the shaft, assemble the loop restorer cam 49, flat washer 48 and the assembled worm gear group.

Assemble tension spring 32 over the hub of the driven clutch 33, spreading the legs of the spring so that they straddle the bent ear at the top of the clutch.

Insert the hub of the driver clutch 31 through the hub of the driven clutch 33, spreading the legs of the tension spring still further away until one of the lugs of the driver clutch is also straddled by the spring legs.

Install the washers 35, 54 and the assembled clutches on to the camshaft. When installed, the bent ear of the driven clutch 33 must be parallel with the camshaft flat for the loop restorer cam 49. Slide the camshaft all the way into place, inserting the end of the camshaft into bearing 30 while locating the large bearing 51 into the seating in the cast arm.

Assemble the two retaining rings 34 to the camshaft, one between washer 48 and loop restorer cam 49, the other between washer 35 and clutch 33. Clutch and loop restorer adjustments will be made after reassembly has been completed (see A3.1).

Fasten the bearing loading spring 28 to the cast arm of the mechanism housing with two screws 27. Assemble the large retaining ring 24 into the ring groove of the housing arm, with the bowed face of the ring against the bearing 51.

Fit inching knob 26 to shaft 52, using screw 25. Insert a 0.019in feeler gauge between the loop restorer

cam and the cast arm of the mechanism housing. Hold the cam firmly against the feeler gauge while tightening the set screw 29 against the flat of the camshaft.

MK4.2.2. Models 1692, 1693 (Fig 17)

Lightly grease both bearing holes in the mechanism housing arms and press the bearing 52 into the mechanism housing. Install the bearing 60 on to the camshaft until it is seated against the shoulder of the shaft 62.

Install the retaining ring 59 into camshaft slot with the convex face away from the bearing 60.

Insert the camshaft, with bearing 60 assembled, through the right-hand bearing hole in the casting arm, and the shaft assembly, the loop restorer cam 58 and worm gear 56. Continue pressing the camshaft to the left, inserting the end of the shaft into the bearing 52 while seating bearing 60 into the bearing hole of the cast arm.

Install the bearing loading spring 51 with the two screws 50. Assemble the large retaining ring 61 with the convex face of the ring against the bearing 60.

Insert a 0.019in feeler gauge between the loop restorer cam and the cast arm of the housing. Press and hold cam firmly against the feeler while tightening the set screw 57 on to the flat of the shaft.

Secure worm gear 56 to the shaft with set screw 55. Fit inching knob 49 to the shaft 62 using screw 48.

MK4.3. Reassembly : shuttle and cam

(Models 1692, 1693, Fig 17. Models 1694, 1695, 1698, Fig 18)

MK4.3.1. Insert straight end of spring 35 through small hole in the shuttle retractor pin 36. Secure the loop end of the spring 35 to the casting with screw 34.

MK4.3.2. Screw the framer knob shaft 33 down into the mechanism housing. Align the stop pin 32 so that the flat side of the pin is parallel with and facing the framer shaft, and press the pin in place. Screw the bearing support 31 all the way up into the staked nut of the shuttle arm plate assembly 30. Engage the fork-like end of the shuttle arm plate framing arm with the cut-out at the lower end of the framer shaft, and fasten the plate to the cast arm of the mechanism housing with the two screws 29.

MK4.3.3. Loosely assemble the in-out cam 25 to the in-out cam bracket assembly 26 (Figs 16, 17) so that the nylon face of the cam follower 27 rides against the polished surface of the cam. Install this assembled group over the end of the camshaft. Rotate the in-out cam 25 until the tongue protruding from the unpolished surface of the cam rests down in the notch in the shoulder of the camshaft. Secure the in-out cam bracket assembly to the cast arm of the mechanism housing with two screws 23 and washers 24. Refit spring 28 or replace if necessary.

MK4.3.4. Refer to Fig 16 and install the assembled aperture plate with screws 76. Then return to original figure and continue with reassembly as follows.

MK4.3.5. Make certain that the shuttle link bearings 20 are firmly pressed into the notches at the front end of each shuttle arm 19 and that the cam followers 21 are assembled into the centre notched section of each arm (Figs 17 and 18). Insert the lubricated cam wiper wick 17 into the coils of the extension spring 15. Assemble the lubricated felt wiper 16 and the extension spring 15 to the shuttle arms (see inserts, Figs 17 and 18). Assemble the ball and stud assemblies 14 to the ends of the arms with the hex nuts 13, tightening the nuts only fingertight. Carefully insert the front ends of the shuttle arms between the guides of the in-out bracket arm so that the shuttle teeth extend through the slot in the aperture plate (for adjustment, see A2.1, A3.3). Assemble the pull-down cam 22 to the camshaft, spreading the shuttle arms lightly until the cam is fully in place. The notch in the inner face of the pull-down cam must engage a mating protrusion on the face of the in-out cam. Back out the bearing support 31 until its socket-like nylon pad engages the ball of the upper stud assembly 14. The ball of the lower stud assembly should rest in the socket of the nylon pad mounted on the shuttle arm plate assembly 30. It may be necessary to loosen the hex nuts 13 and lift the ball and stud assemblies 14 until proper alignment is obtained (for adjustments, see A2.1).

MK4.3.6. Install the fibre washer 12 on the camshaft and up against the pull-down cam 22 so that the hole in the washer is aligned with the slot in the cam. Assemble the shutter 11 to the camshaft and install the counter-balance weight 10 so that its pin engages the slots in the shutter and the pull-down cam. Install the shutter nut 9 with its shoulder in the centre hole of the counterweight. Grip the flats at the end of the camshaft with an open-end wrench and tighten the nut 9 securely.

MK4.4 Reassembling heat baffle, etc

MK4.4.1. Models 1694, 1695, 1698, (Fig 18)

Assemble the grommets 46 into the bracket 45. Assemble a retaining ring 37 into the groove nearest the end of the stop pawl shaft 38 and insert opposite end of the shaft through the shaft pawl 40. Loosely attach the bearing bracket 43 and the clutch stop 42 to the mechanism housing, using screws 41 and washers 47 (for adjustments, see A3.3). Fit tension spring 39 on to the shaft 38. Assemble the bracket 45 to the opposite end of the shaft and fasten bracket to the mechanism housing with screws 44. Tighten screws 41 and 44 securely. Engage spring 39 to stop pawl. Assemble the second retaining ring 37 into the groove of the shaft so that the right-hand ear of the stop pawl is held against the bearing bracket 43. Insert screws 5 through

heat baffle 6, spacers 7, heat baffle 8 and secure to mechanism housing. Fasten the fire shutter assembly 2 to the mechanism housing with four screws 1. Install pulley 4 to the end of the camshaft and tighten the pulley setscrews 3 down on to the flats of the shaft. Models 1692, 1693 (Fig 17). Insert screws 5 through the heat baffle 6, spacers 7, heat baffle 8 and secure to mechanism housing. Fasten bracket 53 to the mechanism housing with four screws 1. Install pulley 4 to end of the camshaft and tighten the pulley setscrews 3 down on to the flats of the shaft.

MK4.5 Reassembling the cam follower, etc (Fig 16)

Attach the self-centering assembly 75 to the mechanism housing with two screws 72, lock washers 73 and flat washers 74. Assemble the lever and shaft assembly 70 to the mechanism housing and install the washer 69 and arm assembly 68 to the end of the shaft. The fork-like finger of the arm assembly must engage the pin of the self-centering assembly between the two large washers. Insert a 0.015in feeler gauge between the washer 69 and the machined boss of the housing. Grip the shaft 70 and arm 68 to hold the feeler gauge while tightening the hex head screw 67, then remove the gauge. Note: The shaft assembly 70, when installed, must be positioned approximately as shown in Fig 16 with the notched area with its upper edge positioned beneath the lower sprocket shaft bearing of the mechanism housing.

If replacements have been made, assemble the cam follower parts 61-66 as shown in Fig 16. Attach this assembled group to the arm assembly 68 with the screw 58 and washer 59. Tighten the screw just enough to hold the follower group. Hook one end of the spring 57 around the end of the lever shaft 70 and secure the other end of the mechanism with the screw 55 and washer 56.

MK4.6 Reassembling kickplate and loop former

If replacements have been made, reassemble the upper loop former and kickplate assembly 47 as follows:-

Insert the kickplate shaft 49 through one ear of the loop former 51 and kickplate 52 and install retaining ring 48. Engage the spring 50 and the second ear of the loop former and kickplate. The spring 50 should tend to rotate the kickplate in a clockwise direction. Insert the shaft and link assembly 44 through the bearing in the mechanism housing. Hook one end of the spring 45 through the small hole in the shaft and link assembly 44. Assemble washer 46 and the kickplate assembly 47 to the protruding end of the shaft 44 and temporarily tighten the setscrews 43.

Attach the upper sprocket guard mounting plate 42 to the mechanism housing with two screws 41. Note: If lens carrier has been disturbed, attach the lens carrier catch 39 and

its flat washer 40 to the mechanism housing with the screw 38. If the hex head lens stop screw 37 has been disturbed, turn it into the tapped hole in the housing until only one thread is visible. It may be necessary to adjust the catch and stop screw at final assembly to ensure proper operation of the lens carrier.

MK4.7. Reassembling shuttle retractor

Assemble the shuttle retractor 35 to the link and stud assembly 36 with the screw 32, lock washer 33 and flat washer 34 and place in position on casting. Assemble the upper loop former assembly 31 to the upper end of the connecting link 36. Insert the shaft of the toggle lever assembly 24 through the small hole on the shoulder of the lower sprocket guard mounting plate 22 and secure with retaining ring 20. Assemble the film guide 25 to the lower sprocket guard mounting plate 22. The stud on the lower arm of the film guide 25 must engage into the smaller of the two forks on the toggle lever assembly 24. Continue to hold this assembly together while engaging the lower pin of the connecting link 36 with the large fork of the toggle lever assembly 24, then slide the large pivot holes of the sprocket guard mounting plate and film guide assembly 22 over the lower sprocket shaft bearing and secure with two screws 15.

Slip the pin end of the threading lever 29 up behind the link 44, engaging the pin with the rectangular slot in the link. Insert the shaft of the upper loop former through the mounting plate 42, the mechanism housing, and into the hub of the threading lever 29. Tighten the hex head locking screw 28 securely. Install retaining ring 30 on to upper pin of connecting link 36 against loop former assembly 31. Attach the leaf spring 27 to the upper loop former with two screws 26. Hook the free end of the spring 45 to the longer arm of the threading lever assembly 29. Assemble one large washer 18 and the lower film guide 19 over the lower sprocket bearing, at the same time inserting the pin at the lower end of the connecting link 36 through the hole in the arm of the film guide 19. Install the second large washer 18 and secure these parts with the retaining ring 17.

MK4.8 Reassembling auto-thread lever, etc

Fasten the back-up bracket 16 to the mounting plate 22 with the screw 15. Assemble the auto-thread lever 11 and bushing 9 to the mounting plate 22 with the threaded stud 8. Fit spring 10 over bushing 9. Hook the short leg of the spring into the hole in the mechanism housing, above and to the left of the bushing 9. Hook the long leg of spring 10 into the V-like notch along the left edge of the lever 11. Fit roller 7 on to the threaded stud 8 and secure with screw 6. Assemble the lower loop former 13 and the tension spring 14 on to the lower pin of the connecting link 36 and install the retaining ring 12. The legs of the spring must bear against the underside

of the loop former in such a manner that they will force the loop former to pivot clockwise around the connecting link pin. Fit film guide exit 79 using screw 78. Fit film guide roller 83 on to shaft of auto-thread assembly 11, also film guide 84; insert screw 82. Fit film guide 81 to auto-thread lever assembly using screw 80.

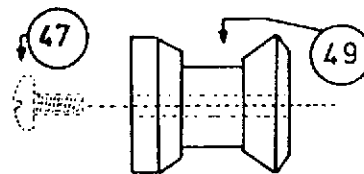

MK4.9 Reassembling lens carrier

Fig 15.

Assemble the pressure plate lever 9 to the pressure plate 7 with the small extrusion of the lever fitted into the corresponding hole in the pressure plate. Thread lever screws 6 through the adjustment plate 12, two springs 8 and fasten them into the pressure plate. Lightly grease the gear teeth of the pinion assembly 15, the pinion slots of the carrier 16 and the notches of the pinion assembly 15 and assemble the pinion into the grooves of the carrier 16. Fasten the spring securely with the two screws 11. Check to make certain that the knob rotates smoothly. Clean the nameplate area of the lens carrier with a cloth dampened with solvent. Replace the original nameplate, if in good condition, using a general purpose impact adhesive. If a new nameplate is to be fitted, remove the backing from the nameplate. Assemble the nameplate to the lens carrier and wipe away any excess adhesive with a soft cloth dampened with solvent.

MK4.10. Reassembling sprockets

Assemble the spring 46 to the shaft of the rewind button 45 and insert the shaft down into the opening in the top of the mechanism. Depress the button and assemble the retaining ring 44 into the groove at the lower end of the shaft. Assemble the thrust washer 38 to the sprocket shaft 37 and insert the sprocket shaft through the upper bearing in the mechanism housing (making sure that the V cut on the sprocket bearings lines up with the upper loop former 31 for ease of entry). Assemble the sprocket guard 29 (parts 30, 31, 32, 35). Slip the assembled sprocket guard 29 up into position beneath the upper sprocket and secure the guard with two screws 28 inserted from the rear of the mechanism housing. Assemble a spring tension washer 27 and the upper sprocket gear 40 to the sprocket shaft and carefully mesh the sprocket gear with the worm gear. Tighten both set screws 39 securely. The sprocket and gear must turn freely with only the minimum of end play. Assemble the sprocket flange 42 and thrust washer 43, and place in position over lower sprocket bearing. Insert lower sprocket shaft 41 through sprocket flange 42 and lower sprocket bearing until fully seated. Assemble spring tension washers 52, 58 and the lower sprocket gear 26 to the sprocket shaft, meshing the sprocket gear teeth with the worm gear. Insert set screw 25 and tighten securely.

Assemble the sprocket guards 48, rollers 49 and tension springs 50 to the tapped mounting posts of the guard mounting plates. Secure with screw 47.

The rollers must be assembled as shown in the drawing. The inner end of each spring is inserted into the small holes in the mounting plates adjacent to the tapped posts. The outer end of each spring hooks over the outer edge of each sprocket guard 48. The springs should tend to rotate the free unmounted edge of each sprocket guard towards the sprocket.

Fasten the hood 24 to the mechanism housing with the two set screws 23. Engage the threading arm 4 (Fig 16), while assembling the actuating lever 22 to the lever shaft. Install the retaining ring 21.

(Fig 15). Hold the assembled lens carrier 8 between the hinge bosses of the mechanism housing. Insert the flat washer 4 on top of the lower hinge boss and the spring tension washer 3 beneath the upper hinge boss. Press the hinge pin 1 into place to hold the lens carrier. If it has been disturbed, adjust the lens carrier catch 39 (Fig 16) so that it holds the lens carrier firmly against the stop screw 37 in the closed position, yet permits the carrier to be opened easily.

ML. SWITCH ASSEMBLY : ANIMATION

(For electrical details see projector wiring diagram.)

ML1. TO REMOVE SWITCH ASSEMBLY

See Picture Z7A.

Remove rear cover (MA1).

Remove top plate (MA2).

Remove gear X and washer Y. If switch is to be replaced, unsolder switch connections.

Remove two hexagon head screws X (Picture Z7B) to release bracket.

Note position of cable retainer and insulating strip.

ML2. TO REPLACE SWITCH ASSEMBLY

See Picture Z7B.

Reverse removal procedure (ML1).

Adjust bracket on elongated slots to obtain free operation of switch by crank arm.

MM. ROTARY SWITCH : MAIN FUNCTION

(For electrical details see projector wiring diagram)

MM1. TO REMOVE SWITCH

See Picture Z8. Note: Do not remove circlip X when requiring access to switch only.

Remove still/run control knob.

Remove main function control knob.

Remove animation switch assembly (ML1).

Remove lower bracket screw.

(For access to still/run switch, leave all push-on connections in position. For replacement of rotary switch, remove all push-on connections.)

Withdraw switch/bracket assembly. Release from bracket by removing hexagon nut and lock washer.

MM2. TO REPLACE SWITCH

Reverse removal procedure.

Clamp switch to bracket in correct position as shown in Picture Z9.

For connection details, see projector wiring diagram.

MN. STILL/RUN SWITCH ASSEMBLY

(For electrical details see projector wiring diagram.)

MN1. TO REMOVE SWITCH ASSEMBLY

See Picture Z11.

Remove animation switch assembly (ML1). Do not remove push-on connections. Remove rotary switch and bracket assembly (MM1).

Release switch by removing two screws A.

Unsolder switch connections and replace actuator parts as necessary (see Fig 6).

MN2. TO REPLACE SWITCH ASSEMBLY

See Picture Z11.

Reverse removal procedure.

Ensure that spring is in position shown at X. Adjust switch bracket to obtain good switch contact without overstressing lower contact strip Y.

For connection details, see projector wiring diagram.

MO. LOUDSPEAKER

(For electrical details, see wiring diagram)

MO1. TO REMOVE LOUDSPEAKER

Remove rear cover (MA1).

Remove top plate (MA2).

Remove speaker side of end plate (MA4).

Remove speaker connections.

Release speaker by removing four speed screws.

MP. FRONT REEL ARM ASSEMBLY

(For adjustment details see A3.8).

Remove rear cover MA1 and top plate MA2.

MP1. TO REMOVE FRONT REEL ARM ASSEMBLY

See Figs 5 or 6.

Remove retaining ring 1, spring washer 36, washer 37, clutch assembly 38, reverse/rewind gear 39 and retaining clip 33.

Remove three screws 4 and release reel

arm disc 23. Withdraw reel arm assembly from main plate. Remove lock button 50 and spring 51.

MP2. TO REPLACE FRONT REEL ARM ASSEMBLY

Reverse removal procedure. Lightly grease all spool arm pivot points.

For adjustments see A3.8.

MP3. TO DISASSEMBLE FRONT REEL ARM

See Fig 11.

The following operations can be carried out without removing spool arm assembly from projector main plate:-

Remove the two screws 1 and lift the reel arm cover 2 from the front arm.

Remove the screw 3 and disassemble the feed spindle assembly 4 from the front reel arm. If spindle parts are damaged, loosen the set screws 6 and remove the lower face gear 7 and washer 8 from the feed spindle 9.

Remove the retaining ring 11 from the spring post in the reel arm to free the end of the torsion spring 15. Loosen the set screws 12 and lift the upper face gear 13, sleeve 14 and torsion spring 15 from the reel arm shaft 18.

Remove the retaining ring 16 and withdraw the reel arm shaft 18 and washer 17 from the reel arm.

Remove the retaining ring 19 and withdraw the upper spur gear 20 from the gear shaft 24. Remove the two gear retaining clips 21, the washer 22, the lower spur gear 23 and slide the gear shaft 24 from the bearing posts of the reel arm. Inspect the nylon bearings 25 and, if damaged, press them from the bearing posts.

MP4. TO REASSEMBLE FRONT REEL ARM

See Fig 11.

Assemble the washer 8 and the face gear 7 down against the shoulder of the feed spindle 9. Install, but do not tighten, the two set screws 6.

Place the reel arm 26 on the bench with the lower (spindle) end of the arm at your left. Assemble the nylon bearings 25 into the cast bearing bosses of the reel arm, engaging the key tabs of the bearings with the cross slots in the bearing bosses.

Insert the gear shaft 24 through the nylon bearings from right to left, making sure that the end with the flats furthest from the tip of the shaft is at the right (upper end of the reel arm).

Assemble the lower spur gear 23 to the left end of the shaft. The gear face with the square recess must face away from the cast bearing boss.

Install the gear retaining clip 21 to the flats of the gear shaft. Assemble the washer 22 and the second gear retaining clip 21 to upper end of the gear shaft 24.

Assemble the upper spur gear 20 to the shaft, with the square recess of the gear engaging the retaining clip. Install the grip ring 19 on the end of the shaft.

Insert a 0.010in feeler gauge between the upper spur gear 20 and washer 23 and press the grip ring in against the gear. Remove the feeler gauge.

Place a drop of oil at the unflanged end of the reel arm upper bearing. Insert the long end of the shaft 18 through the upper bearing and install the thrust washer 17 and the retaining ring 16.

Assemble sleeve 14 to gear 13. Apply a light coat of grease to the gear teeth and to the hub of the face gear.

Assemble the torsion spring 15 to the hub of the gear with the loop end of the spring furthest from the gear teeth.

Assemble the face gear to the reel arm shaft while engaging the loop end of the spring over the spring boss of the reel arm.

Secure the loop with the retaining ring 11 and tighten the gear set screw 12 securely. The retaining ring 11 must not be so tight as to restrict movement of the spring loop when the face gear is rotated.

Apply one drop of oil to the flanged end of the reel arm lower bearings. Insert the shaft down through the reel arm bearing. Install and tighten the screw 3 securely.

Rotate the face gears 7 and 13 in both directions to check backlash. There should be approximately 0.005in to 0.018in backlash around the total circumference of each gear. Loosen the gear set screws 6 or 12 and reposition the engagement of face gears with spur gears until proper backlash is obtained, then tighten set screws securely.

Replace reel arm cover 2 using screws 1.

MQ. REAR REEL ARM

Remove rear cover (MA1), top plate (MA3) and rear end plate (MA3).

MQ1. TO REMOVE REAR REEL ARM ASSEMBLY

See Figs 5 or 6.

Remove retaining ring 1, to release gear and bearing assembly 21, and second retaining ring 1.

Remove three screws 4 and disc 23. Withdraw reel arm assembly from main plate and remove lock button 50 and spring 51.

MQ2. TO REPLACE REAR REEL ARM ASSEMBLY

Reverse removal procedure MQ1.

For adjustments see A3.8.

MQ3. DISASSEMBLING REAR REEL ARM ASSEMBLY

See Fig 12.

The following operations can be carried out without removing the assembly from the main plate:-

Remove the two screws 1 and lift the reel arm cover 2 from the rear arm 31. Remove tension spring 4. Press the take-up arm 10 against the reel arm casting and slip the take-up belt 3 from the pulleys.

Remove the screw 7 and disassemble the take-up spindle and pulley assembly 8 from the take-up arm.

Press out pin 5 if replacing take-up arm 10. Remove retaining ring 11, nylon bushes 12 and gear 13 from the end of the gear shaft 16.

If replacing, loosen the gear set screw 14 and disassemble the gear 13, the shim washer 15 and the gear shaft 16 from the reel arm.

Remove the retaining ring 17 from the spring post in the reel arm to free the end of the tension spring 18 and lift the tension spring from the hub of the upper face gear 26.

(To replace above parts refer to MQ4.)

If further disassembly is required, continue as follows:-

Remove the retaining ring 19 and slide the upper spur gear 20 towards the upper face gear 26 until the upper gear retaining clip 21 and washer 22 can be removed.

Move the gear shaft 24 down until the lower spur gear 23 can be removed.

Remove the lower gear retaining clip 21 and lower spur gear 23, and slide the gear shaft 24 from the bearing posts of the reel arm. Inspect the nylon bearings 25 and, if damaged, press them from the bearing posts.

Loosen the set screw 14 and lift the upper face gear 26 from the reel arm shaft 30. Remove the retaining ring 27 and disassemble the reel arm shaft 30 and washer 28 from the reel arm.

MQ4. TO REASSEMBLE REAR REEL ARM

See Fig 12.

Apply one drop of oil to the unflanged end of the bearing in the rear reel arm. Assemble one retaining ring 27 to the rear reel arm shaft 30 in the groove nearest the two narrow flats on the shaft.

Assemble the thrust washer 28 over the long end of the shaft and down against the retaining ring. Insert the shaft through the reel arm bearing.

Assemble the upper face gear 26 to the reel arm shaft 30, gear teeth facing up, and tighten set screw 14 against flat of shaft.

Assemble the nylon bearings 25 into the cast bearing arms of the rear reel arm, engaging the key tabs of the bearings with the cross-slots of the bearing holes.

Assemble the lower spur gear 23 to that end of the gear shaft 24 where the flats are nearest the end. The gear face with the square recess must face away from the cast bearing boss. Install the gear retaining clip 21.

Insert the gear shaft through both nylon bearings 25. Assemble the washer 22 and gear retaining clip 21 to the end of the gear shaft.

Install the upper spur gear 20, square recess facing inward to engage retaining clip 21, and assemble the retaining ring 19 to the end of the shaft. Insert a 0.010in feeler gauge between the upper spur gear 20 and

washer 22 and press the retaining ring 19 in against the gear. Remove feeler gauge.

Insert the small diameter end of the gear shaft 16 up through the hole in the lower end of the reel arm. Hold the shaft in place and assemble the washer 15. Install the lower face gear 13 and the two nylon bushes 12 to the gear shaft. Secure these parts with the retaining ring 11.

Install the set screw 14 into the tapped hole in the reel arm casting near the lower end of gear shaft 16. Do not tighten the set screw.

Move the gear shaft 16 to engage the teeth of the lower face gear 13 with the lower spur gear 23 and tighten the set screw 14.

Rotate the face gear in both directions to check backlash. There should be approximately 0.005 to 0.018in backlash around the total gear circumference. If necessary, loosen the set screw 14 and remesh gear teeth until correct backlash is obtained, then tighten set screw securely.

Apply a light film of grease to all gear teeth and to the hub of the upper face gear 26. Assemble the torsion spring 18 to the hub of upper face gear 26 with the loop of the spring over the casting boss near upper spur gear 20. Secure the spring loop to the boss with the retaining ring 17. Rotate the upper face gear in both directions to make certain that the retaining ring does not restrict movement of the spring loop on the boss. Reposition retaining ring if necessary.

Apply one drop of oil to the mouth of the bearing in the take-up arm assembly 10. Assemble the washer 9 to the shaft of the take-up spindle 8 and insert the shaft through the take-up arm bearing. Install and tighten the screw 7.

Assemble the take-up arm 10 to the reel arm using pin 5. Assemble the take-up belt 3 around the spindle pulley and the rubber sleeve of the lower face gear (Picture Z12).

Insert the tension spring 4 into the recess in the take-up arm and compress the spring with a piece of shim stock while assembling the reel arm cover 2 to the reel arm.

For adjustment see A3.8.4.

MR. BLOWER ASSEMBLY

(For electrical details see projector wiring diagram.)

Remove rear cover (MA1), top plate (MA2) and rear end plate side MA3.

MR1. TO REMOVE BLOWER ASSEMBLY

(See Fig 7)

Unplug motor connector.

Release assembly from projector base by removing four hexagon head screws 5. Release motor by removing three side cover screws 7 using Bristol "L" S072 key to remove fan/hub assembly retaining screw 11.

A Adjustments

WARNING. Many of the procedures listed in this section require operation with the covers removed. To avoid electric shock hazards, disconnect the power when not required. The use of an isolation transformer is recommended.

The alignment and adjustments covered in this section are necessary to the proper operation of the projector. Even though the projector may not have undergone complete overhaul and repair, it is recommended that all adjustments be checked as a routine measure. Routine adjustments such as those applicable to sliding fits, clearances and play have been covered in the reassembly procedures and are not repeated here except where they directly affect other adjustments or alignments.

All special tools and fixtures required to perform the adjustment procedure are illustrated in the Tools and Gauges section of this manual. In addition, special test films and electronic test equipment (valve voltmeter, volt-ohmmeter, oscillator and tachometer or stroboscope) are needed to check and adjust the sound system.

A1. OPTICAL ALIGNMENT

It is important that these alignments be performed in the following sequence. All special tools and fixtures required for optical alignment are shown in the Information section.

Be sure to turn the mechanism manually until the shutter blade is clear of the aperture opening.

A1.1. ALIGNING THE APERTURE PLATE

Remove the projection lens from the lens carrier. Remove the lamphouse assembly and the projection lamp.

Swing the lens carrier fully open and disassemble the pressure plate from the lens carrier.

Loosen the two aperture plate mounting screws just enough to permit movement of the aperture plate, and insert the aperture plug (4, Picture A) into the aperture opening. Close the lens carrier.

Tip the projector carefully on to its back (lens opening facing up) and insert the lens plug (2) down into the lens barrel. Insert the end of the alignment rod (3) into the centre hole of the lens plug and carefully lower the rod. It may be necessary to shift the aperture plate slightly so that the alignment rod enters the hole in the aperture plug. With the alignment rod in place, tighten the two aperture plate mounting screws.

A1.2. ALIGNING THE LAMP SOCKET

Tip the projector back into its normal upright position and reassemble the

Disassembly and Assembly

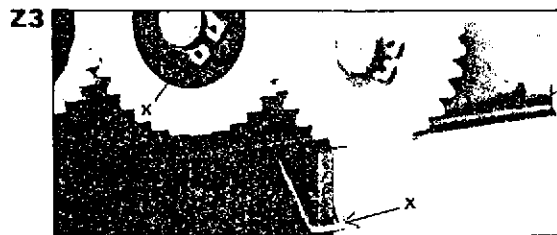
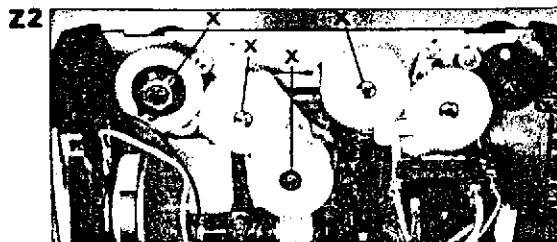
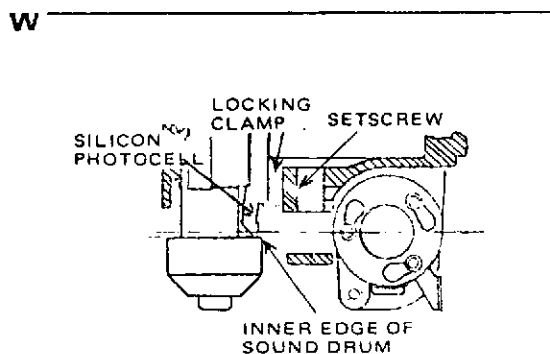
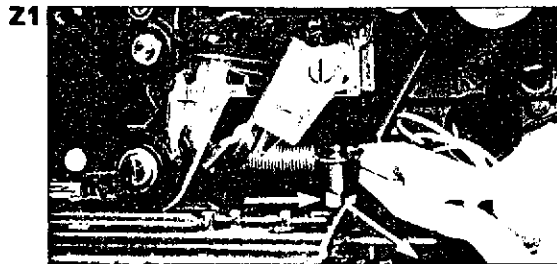
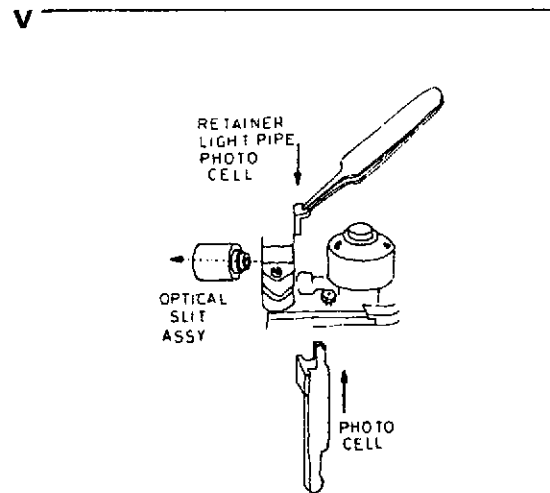
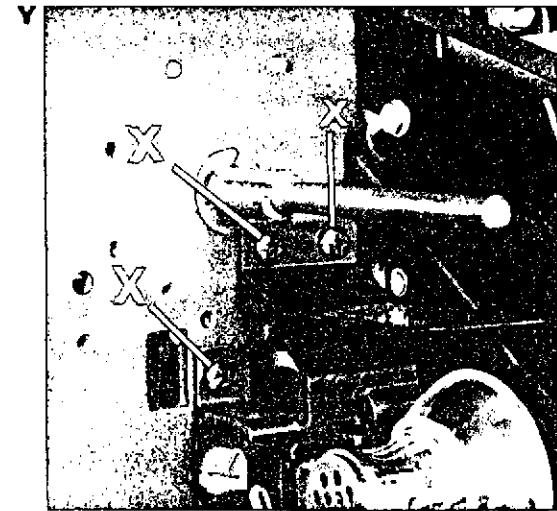
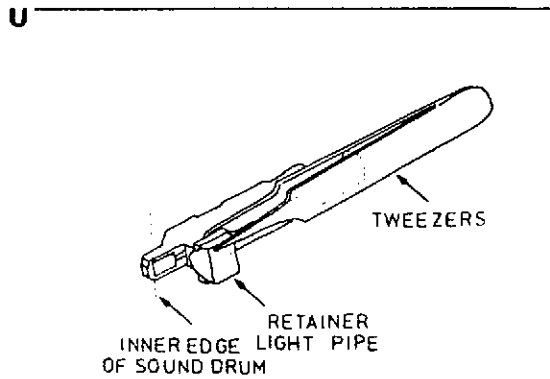
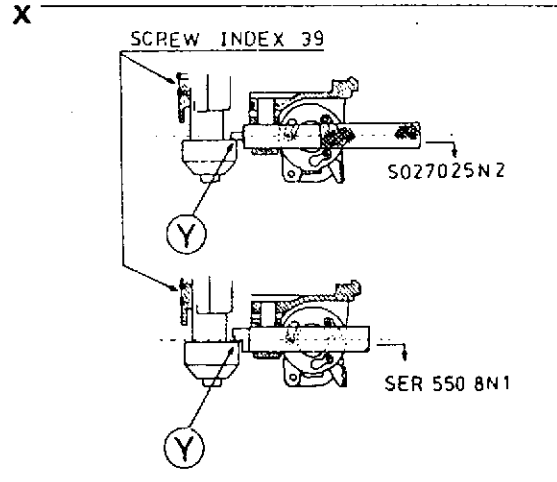
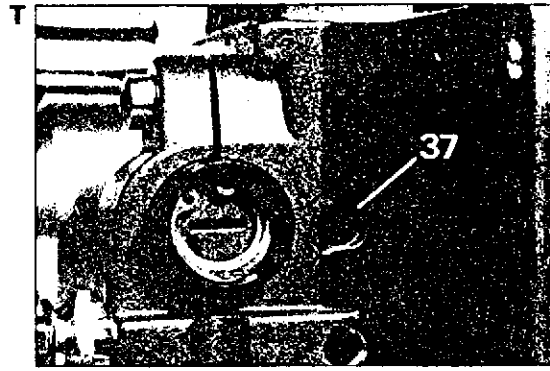

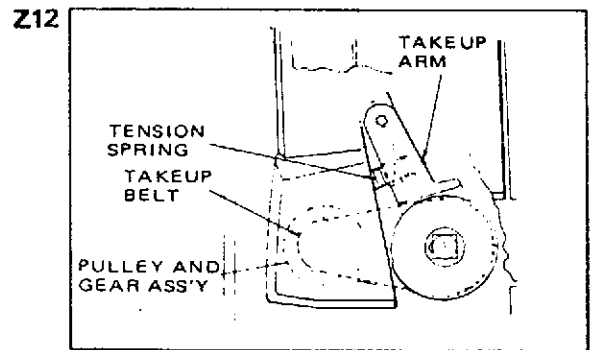
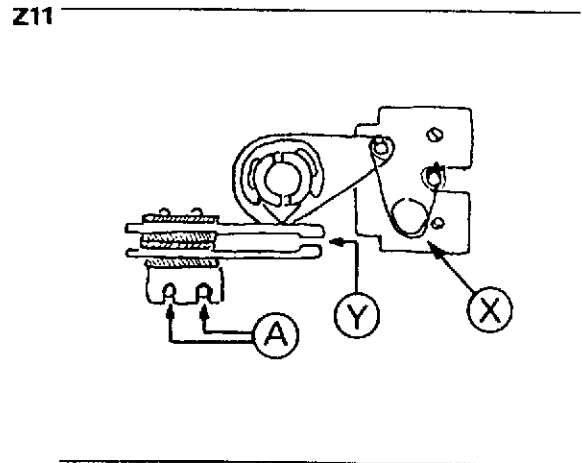
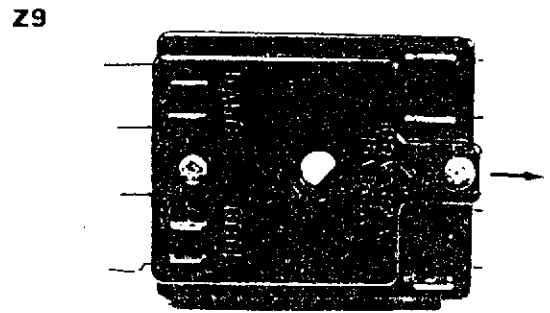
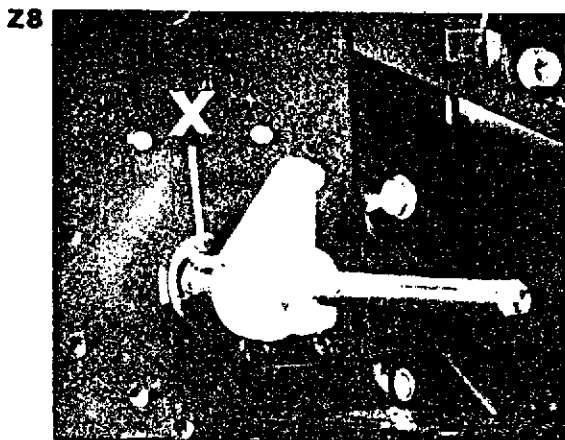
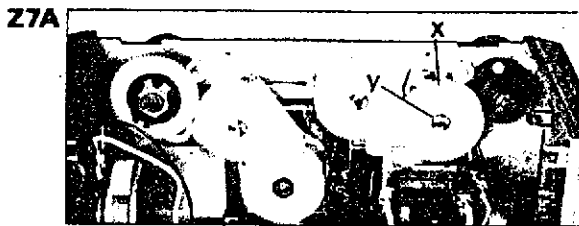
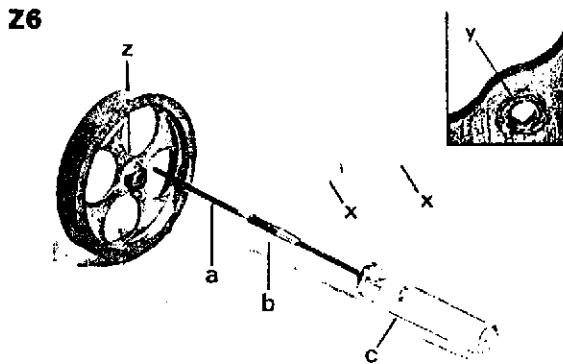
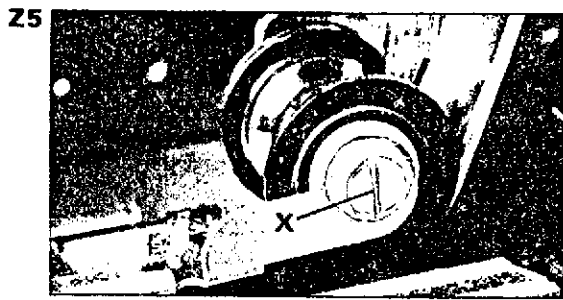
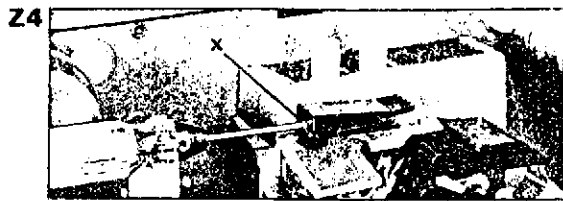

pressure plate to the lens carrier. Close the lens carrier.

Loosen the three lampholder mounting screws just enough to permit movement of the lampholder. Insert lamp plug (1) into lamp socket and engage the lamp retaining clip.

Slide alignment rod completely into place until tip of rod engages the hole in lamp plug. Shift socket as necessary until rod slides freely in the lamp plug hole. Then tighten the screws securely and remove all tools.

A2. INTERMITTENT SYSTEM

A2.1. ADJUSTING SHUTTLE TOOTH

A2.1.1. Checking Shuttle Tooth Side Clearance

Advance the mechanism manually until the shuttle is at the centre of its stroke as shown in Picture B. The clearance from the edge of the shuttle slot to the inner end of the shuttle tooth (nearest the aperture opening) should be 0.009in. From the edge of the shuttle slot to the outer end of the shuttle tooth, the distance should be 0.050in maximum. Check these clearances at both upper and lower teeth. If the clearances vary at the upper and lower teeth and inner clearance is less than 0.007in at either end, the following possible causes should be checked and corrected:-

A2.1.2. Checking Shuttle Tooth Height

Swing open the lens carrier and advance the mechanism manually until the shuttle is at the centre of its stroke as shown in Picture C. Hold the shuttle tooth height gauge (Tool 6) by its knurled handle and place it against the aperture plate between the rails. The centre ears, on either side of the gauge handle, are the height gauges. Slowly slide the gauge downward. The "Go" ear should pass over the shuttle tooth without catching. Rotate the gauge so that the "No-Go" ear is over the shuttle slot and once more slide the gauge downward. The "No-Go" ear must not pass over the shuttle teeth. If the shuttle teeth are too high or too low, adjust height as follows.

Note: If the mechanism assembly is installed on the main frame, it will be necessary to remove the lamphouse cover door, lamp 27 (Fig 2) and the lampholder 30.

Turn the mechanism drive pulley by hand until the access holes in the fire shutter brackets are aligned.

Insert a Bristol wrench DS.060 into the access openings and engage it in the socket of the in-out cam follower screw.

If the shuttle teeth were too low (No-Go ear passes over shuttle teeth), turn the cam follower screw counter-clockwise to increase shuttle tooth height. If the shuttle teeth were too high (Go ear catches against shuttle teeth), turn the cam follower screw clockwise. It may be necessary to re-check shuttle tooth height with the gauge several times before the proper height has been obtained.

If one of the teeth cannot be brought into tolerance by the above method it may be necessary to loosen the screws which attach the in-out bracket (Picture C) and shift the bracket slightly. Tighten the mounting screws securely. Check and adjust shuttle tooth height as outlined above.

A2.1.3. Checking Fit of Shuttle Arm to Pull-Down Cam. (see Pictures D and E).

The following adjustment has to be made with the mechanism installed on a mounting bracket (see Information section). If mechanism has just been lubricated, run it for two or three minutes before proceeding with this adjustment.

Open film gate and turn projector mechanism by hand until shuttle teeth are retracted and have moved downward to approximately the centre of the stroke (centre tooth approximately on horizontal centre line of aperture). Slip guide bars of tool over casting to which shuttle mounting plate is attached. When tool is positioned so that arm or stud B can bear on shuttle arm C, tighten thumbscrew A just enough to hold tool in position.

Engage hook of tool 9 on slot of arm or stud B as shown and allow weight 9 to swing downward. Tilt, if required, so that the weight does not rub on any stationary parts.

Loosen upper support assembly (F) approximately one turn. Rotate projector framer knob so that pointer moves above witness line selected. Then turn framer knob in the opposite direction until pointer moves back down to witness line or Mark H (Picture D). If adjustment of framer knob does not permit movement of pointer as specified, it may be necessary to rotate the camshaft slightly to bring cam into the proper position.

Carefully tighten upper bearing support assembly F while observing alignment of pointer with witness line. The instant the pointer starts to move upward, stop turning support assembly F. This is the proper adjustment.

Do not tighten the shuttle arms more than is specified in an attempt to remove cam noise. Excessive tightening will reduce life of cam and cam shoes.

A2.1.4. Checking Shuttle Stroke. Shuttle stroke (vertical travel of shuttle teeth) is 0.3025in and can be checked by using a clock indicator according to normal engineering practices. Any deviation from this figure indicates cam wear and a replacement should be fitted.

Framing Adjustment. Thread the projector with film having proper frame line position. Project film and turn framing knob from one limit to the other. If at one limit a frame line is not visible, loosen nut on the framing eccentric located at top of shuttle arm plate assembly 30 (Figs 17, 18) until frame line appears. Hold eccentric while tightening nut. Check adjustment by again turning frame knob from limit to limit while observing picture. When the eccentric

is properly adjusted, either frame line can be projected and movement of film should be approximately equal at top and bottom of framer travel.

A3. FILM TRANSPORT SYSTEM

A3.1. LOOP RESTORER ADJUSTMENTS

Note: With experience, the following adjustments may be carried out without removing the mechanism assembly from projector. However, if mechanism has already been removed during service, install mechanism on a mounting bracket (see Information section).

Check operation of loop restorer by threading the projector with a loop of test film in which groups of three successive perforations have been purposely removed at points approximately 1ft apart. The first set of damaged holes should be located about 2ft from the aperture. Run the projector in "forward" and observe the action of the loop restorer as the missing perforations run through the film gate. The lower loop should be automatically restored within five or six frames. To adjust the loop restorer, refer to Picture F and proceed as follows:

Slip the loop restorer position tool (7, Information section) over the loop restorer roller. To adjust spacing between loop restorer and guide roller at the rear end of the upper sprocket guard, loosen the mounting screws in the self-centering assembly and raise or lower that assembly until the proper spacing is obtained. Then tighten the mounting screws securely. Be sure that the ear of the loop restorer arm is positioned between the two spring-loaded keeper plates of the self-centering assembly.

Rotate the mechanism pulley until the set screw in the loop restorer cam is at the bottom, directly below the camshaft (Picture G). The clearance between the upper tip of the cam follower blade and the face of the cam should be 0.015in. To adjust this clearance, loosen the cam follower support mounting screw (Picture F) and rotate the support accordingly; then retighten the screw securely. Now check the clearance between the upper end of the cam follower and the small diameter of the loop restorer cam (Picture G). This clearance should be 0.040in. (± 0.005 in). Be sure that the cam set screw is still positioned at the bottom of the cam, below the camshaft. To adjust this clearance, loosen the two follower screws and raise or lower the cam follower blade as necessary, then retighten the two screws securely.

Recheck the clearance between the loop restorer roller and upper sprocket guard guide roller as outlined above. Remove the restorer positioning tool and once more check loop restorer operation with the loop of test film.

A3.2. TIMING THE SPROCKETS

(Tools 10, Information section). Open film gate and turn the framer shaft fully down. Then turn the mechanism manually until the shuttle is at the bottom of the stroke (teeth

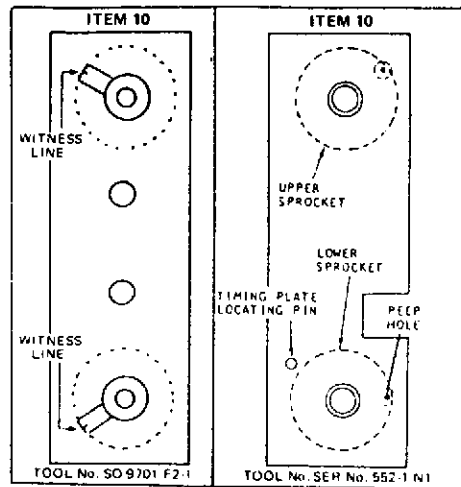

protruding) and the edge of the shutter blade bisects the aperture opening. Open the sprocket guards and place a timing plate 10 over the sprocket hubs. Note which sprocket teeth are nearest to the witness line or peep-holes of the timing plate. If the sprockets are properly timed the witness lines will line up to the sprocket teeth. If using Tool 10 with peep-holes, remove the timing plate and place a pencil mark on the face of each sprocket (near the rim) exactly in line with the sprocket teeth which were nearest the peep-holes. Then reinstall the timing plate on the sprocket hubs. If the sprockets are out of time proceed as follows:

To retime the feed (upper) sprocket, loosen the sprocket set screws 39 (Fig 15) in the hub of the upper sprocket gear 40. Rotate the sprocket until the tooth aligns with upper witness line or peep-hole. Then tighten up set screws securely.

To retime the take-up (lower) sprocket, loosen the set screws 25 (Fig 15) in the hub of the lower sprocket gear 26 and rotate the sprocket until the tooth or pencil mark aligns with the peep-hole or witness line. Then tighten gear set screws securely. **Note:** sprocket shafts should have approximately 0.003in end play when tension washers 52 and 58 (Fig 15) are fully compressed.

A3.3. Checking Shuttle Retraction.

Turn the mechanism pulley by hand while pressing down on the clutch pawl at a point where the clutch rod passes through it. The ear of the clutch pawl should latch behind the trigger as shown in Picture J. Note also the clearance required between the finger on the clutch yoke and the curved arm of the strike. Adjust as follows:

Loosen the clutch strike screw (Picture I) to permit the strike to be shifted. Insert a 0.015in feeler gauge between the clutch yoke finger and the strike arm. Press and hold the strike against the feeler gauge while retaining the strike screw. Remove the feeler gauge.

(Picture J). Loosen the round Allen nut slightly and shift the shuttle adjustment bracket slowly toward the shuttle (to the right)

until the shuttle teeth are retracted below the lever of the aperture plate rails. Retighten the Allen nut.

(Picture K). Adjust the set screw in or out to obtain a clearance of 0.094in between the left-hand ear of the worm gear. Note (Picture J) that the curved lip of this retainer must overlap the downward bent finger of the clutch slide bar. If necessary, bend this finger to obtain positive overlap as shown.

A3.4. ANIMATION CLUTCH

A3.4.1. Checking Stop Pawl to Trigger Clearance. Rotate the mechanism by hand until the finger of the trigger is adjacent to the inner bent ear of the stop pawl as shown in Picture H. If the trigger fails to clear the stop pawl ear, adjust as follows:

Loosen the clutch stop screws 41 (Fig 19) and shift the clutch stop 42 up or down, as necessary, to obtain approximately 0.010 to 0.015in clearance between the stop pawl ear and the end of the trigger; then tighten the two clutch stop screws securely.

A3.4.2. ADJUSTING CLUTCH SOLENOID LINKAGE

Refer to Fig 7 in the parts list section for the following adjustment procedure. The clutch stop must be disengaged as shown in Picture H.

Loosen the collar set screws 26 so that both collars are free on the clutch solenoid rod 29.

Lift the clutch solenoid rod until the top of the solenoid plunger is raised approximately 3/16in out of the solenoid frame. Hold in this position and slide the lower collar up against the stop pawl (Picture H). Tighten collar screw securely.

Position the upper collar so that the distance from its top surface to the bottom of the lower collar is approximately 7/8in. This should provide sufficient compression to the spring 28 to prevent chatter.

Start the projector and check the operation of the clutch. If the solenoid pulls in sluggishly, the plunger is set too high. Hold the solenoid rod and lower collar while loosening the collar set screw. Lower the collar a fraction of an inch on the rod and retighten the set screw. Then recheck clutch operation. If the solenoid produces a buzzing noise, it is again too high (lower the bottom collar) or the spring is compressed too much (loosen upper collar set screw and raise slightly). If the plunger seats fully but the stop pawl ear does not engage behind the trigger (Picture H), the plunger is either set too low or the spring is not sufficiently compressed. Reset the collars accordingly.

A3.5. ADJUSTING THE FIRE SHUTTER

Turn mechanism pulley until one blade of the interrupter shutter is adjacent to fire shutter rod 1 (Fig 9). Check that rod clears interrupter shutter by

at least 3/32in. If clearance is less than 3/32in, remove solenoid and loosen the two bracket retaining screws. Shift bracket to provide minimum link clearance of 3/32in, then tighten retaining screws securely and reinstall the solenoid.

To align, open film gate and turn mechanism pulley until interrupter shutter clears the aperture. Loosen two screws which secure solenoid to main plate assembly. Place thumb of left hand against outer end of solenoid frame and index finger on clevis, not on the linkage. Press solenoid against plunger. While looking straight into aperture, position solenoid so that fire shutter covers aperture; then tighten screws at outer end of solenoid bracket enough to hold solenoid in place. Release solenoid plunger and raise or lower the rod several times to make sure that the plunger slides freely in solenoid. Tip solenoid if necessary to free plunger, then tighten both retaining screws securely.

A3.6. AUTO-THREAD SYSTEM : GENERAL

The auto-thread system consists of a series of guides and rollers which, when the system is in the "load" position, are so located as to guide the film through the threading path. When the system is in the "open" position, the guides and rollers clear the film path.

When the system is in the "open" position, the location of the guiding parts is not critical. Therefore adjustments to ensure proper location of the guiding parts are made with the system in the "load" position.

The guides are connected by a mechanical linkage. The system is actuated by a cocking lever at the lower end of the linkage. The specified clearances must be checked with the system in the "load" position. If the need for adjustments is detected, it is important that the repairman proceeds in the sequence listed in this section. The sprocket timing and the location of the sound head may be done without disturbing the guide adjustments.

A3.6.1. Adjusting the Loading Guides.

Open the film gate and upper take-up sprocket 1 (Picture L) and remove the retaining screw 2.

Place timing plate (Tool 10) over the sprocket hubs 3 and 4. The timing plate locating pin should enter the counterbore from which screw 2 is removed. If the locating pin does not enter the counterbore, loosen the three sprocket guard plate attaching screws 1 (Picture M) and rotate the lower guard plate 2 until the pin enters hole. Then tighten the three screws securely.

Remove retaining ring that secures the actuating assembly (Picture L) and lock the auto-thread system. Place a 0.015in feeler gauge between the film support rails of the aperture plate and the rear surface of the lower loop form assembly 4 (Picture M). This surface should touch the feeler gauge just as the heel of the loop form 5 strikes the shoulder of the mounting stud for the entrance guide roller 6.

To adjust, loosen the screws 7 which attach the upper sprocket guard plate. Press downward on front end of loop form assembly and rotate upper sprocket guard plate until heel of loop form strikes shoulder of stud and rear surface clears aperture rails by 0.015in. Then tighten screws 7 securely.

Depress and hold the lower loop form assembly 4 (Picture M) and check, at rear of mechanism, that the pin in the threading lever clears the bottom of the elongated slot in the loop form shaft link by approximately 1/64in (Picture N). If necessary, loosen the hexagon-head screw that secures the threading lever and rotate the lever to obtain the proper clearance, then re-tighten the hexagon-head screw.

Check operation of the film escape mechanism by leaving the auto-thread system open. Manually advance the film and jam it in the upper channel. The film should fold and flow out through the kickplate in the loop form and kickplate assembly 14 (Picture L).

Again depress the loop form assembly 4 (Picture M) and make certain that there is 0.015in clearance between the top surface of the kickplate 8. If adjustment is required, remove the two screws which attach the hood 9. Loosen two set screws 10 and rotate kickplate 8 to obtain desired clearance. Tighten set screws and reinstall hood. Before tightening hood retaining screws, press hood toward rear of the projector.

With the auto-thread system locked and film gate open, check that the shuttle teeth do not protrude. Loosen screw 6 (Picture L) and carefully raise the shuttle retractor 7 until teeth are retracted, then tighten screw 6 securely. Caution: the top end of the shuttle retractor must not strike the casting.

Close the film gate while checking that the film pressure plate seats squarely against the aperture plate. If pressure plate makes contact with the film guide rails, either the pressure plate lift-off ear 8 (Picture L) or the ear on the threading guide linkage is bent. Reform ear, or ears, as necessary.

Loosen the screw 10 (Picture L) and align the film guide 11 so that the film will feed squarely to the sprocket, then retighten the screw 10.

Loosen screw 11 (Picture M), lock the system, and check that loop form heel 5 is bearing on shoulder of roller stud 6. If necessary, rotate the eccentric pivot 12 with a wire pick or pin punch until heel bears against stud shoulder. Recheck clearance between rear of loop form and aperture rails. Also make certain that end of upper loop form 8 is tangent to or slightly ahead of the plane of the aperture plate film guide rails. Readjust if necessary.

Install actuating assembly 5 (Picture L) and press it down to make certain that the system does not lock. If system locks when actuating assembly is depressed, remove the assembly and raise the set screw protruding from the boss in casting. This set screw acts as a stop for the actuating assembly. When the height of the set

screw is properly adjusted, seal set screw with shellac or cement and reinstall actuating assembly with retaining ring.

Lock the system and try to insert film into the feed sprocket. If the film slips in too freely, loosen the two screws 3 (Picture M) and move leaf spring 13 downward to increase pressure on the film. If film buckles as it is inserted, move leaf spring upward to reduce pressure, then tighten screws 3.

A3.7. LENS CARRIER ADJUSTMENT

The angular relationship between the lens carrier and the aperture plate is controlled by the lens mount stop screw. Thread projector with target film or other film having sharp images in corners and project picture approximately 30in high on to a matt surface. (Note: projector must be square with the screen.) Focus the picture and compare resolution of the two sides of the image when viewed from a distance of approximately twice the width of the picture. If one side appears to be soft, refocus to sharpen that edge of the picture and note whether the lens is moved towards or away from the aperture. For example, if image at right-hand edge of screen is soft until lens is moved toward aperture, then lens stop screw is set too far forward and should be turned clockwise, and vice versa.

A3.8. ADJUSTING REEL ARMS AND REWIND CLUTCH

A3.8.1. Rear Reel Arm (Fig 12). Adjust end play of shaft 24 to 0.008in + 0.003in by positioning retaining ring 19 against an 0.008in shim. The backlash on the upper gear assembly 26 should be 0.015in + 0.003in. Adjust by increasing or decreasing built-up 0.005in and 0.0025in washers 28 as required beneath the upper gear assembly 26. Greater thickness in washer combinations reduces backlash.

A3.8.2. Front Reel Arm (Fig 11). Adjust end play of shaft 24 to 0.008in + 0.003in by positioning retaining ring 19⁻ against an 0.008in shim. The backlash on the lower gear assembly 7 should be between 0.005in minimum and 0.018in maximum. Adjust by assembling a combination of washers as required. Greater thickness in washer combinations reduces backlash.

A3.8.3. Reverse Take-Up. The reverse take-up system must be adjusted to produce to take-up spindle torque of 510 grams maximum with a 400ft reel and loaded with 15ft of film, and 57 grams minimum with an 800ft reel fully loaded. Using method shown in Picture O, make a hole in the end of film to secure torque gauge. Hold torque gauge firmly in horizontal position; do not increase torque by pulling against gauge. Read measurement as shown at witness mark. This measurement should be within the limits quoted above.

To adjust reverse take-up torque, remove clutch assy 38 (Figs 5 & 6), fit suitable spanner over hexagon nut on 38 and tighten or loosen as necessary, while holding flats on clutch. Refit and check to specification.

A3.8.4. Forward Take-Up. Forward take-up should produce a torque of 57 grams with a 400ft spool loaded with 15ft of film and 57 grams to 227 grams with an 800ft spool fully loaded. Using method shown in Picture O1, make a hole in the end of film to secure torque gauge. Hold torque gauge firmly by pulling against gauge. Read measurement as shown at witness mark. If readings shown do not comply with test specification, first check condition of take-up belt 3 (Fig 12), replacing if signs of wear are evident.

A3.8.5. Rewind Clutch Adjustment. The rewind clutch system must be adjusted to produce a supply spindle torque of 400-550 grams with a 400ft reel fully loaded. Using method shown in Picture O, make a hole in the end of film to secure torque gauge. Hold torque gauge firmly in horizontal position; do not increase torque by pulling against gauge. Read measurement as shown at witness mark when the rewind button is pressed during operation. This measurement should read 400-550 grams as quoted above. To adjust rewind take-up torque, remove clutch assy 35 (Figs 5 & 6) fit suitable spanner over hexagon nut on 35 and tighten or loosen as necessary while holding flats on clutch. For location see Picture P. Refit and check to specification.

A3.9. GEAR SHIFT TENSION ADJUSTMENT

When shifting from forward to rewind, or vice versa, the idler gear arm (Picture P) should pivot smoothly to effect the engagement of the idler gear with gear "A" or gear "B". This can be checked by rotating the drive belt pulley manually, first in one direction and then the other. If the pivoting action seems hesitant, increase the tension on the arm assembly by pressing the retaining ring more firmly on the spur gear shaft until the bowed washer is flattened against the face of the gear.

A3.10. IDLER GEAR BACKLASH ADJUSTMENT

In both the forward and rewind positions, there must be a perceptible amount of backlash between the idler gear and gears "A" and "B" (Picture P). As the idler arm pivots, a stop pin protruding at the upper end of the arm rides the slightly curved rim of the adjustment bracket from one limit stop to the other. Check gear backlash at both limit stops. If there is no backlash at one stop and too much at the other, loosen the adjustment bracket screws and shift the bracket slightly to balance the backlash in both positions.

A4 SOUND HEAD : OPTICAL

A4.1. ROLLER TENSION ADJUSTMENT

With film being transported through the mechanism and sound head assembly, in the normal manner, the following adjustments may be made to obtain optimum stabilisation of the upper and lower tension arms. The roller arms are linked by counterbalance springs which can be individually adjusted to obtain correct stabilisation.

To adjust upper roller arm, engage the slotted head of the tension adjuster (Picture Q) with a screwdriver and turn the adjuster clockwise or counterclockwise until correct counterbalance is obtained.

To adjust lower roller arm, hold spring lug 46 (Figs 13 & 14) and engage Philips screwdriver into locking screw (Picture R). Adjust, to enable tension to be increased or decreased on lug 46, to obtain correct stabilisation. Resecure Philips screw.

A4.2. POSITIONING THE SOUND HEAD

Lock the system in the "thread" position. Loosen the three screws 13 (Figs 8 & 9) which attach the sound head to the main frame casting.

Hold the sound head locating gauge 11 (Picture S) and insert it carefully between the sound drum and take-up sprocket as shown. The gauge must be between the sound drum threading guides. Position the gauge so that one end bears against the supporting ribs for the sound track edge of the film and with the gauge in contact with the rear sprocket flange, as shown.

Tilt the gauge so that it lies on the centre line between the take-up sprocket and the sound drum. Shift the sound head toward the take-up sprocket until the sound drum bears lightly against the end of the gauge, and tighten the sound head attaching screws securely.

A4.3. OPTICAL SLIT ADJUSTMENT

Insert the optical slit (Figs 13 & 14, P/N 020240) into its opening in the sound head. One adjusting hole in the barrel of the slit must be at top centre.

Insert a 0.050in feeler gauge between the tip of the optical slit and the sound drum and press the optical slit in against the feeler gauge. Hold in this position while tightening the locking screw 34 just enough to hold the slit in place.

Thread the projector with a 7000Hz optical setting film and connect a 16 ohm, 10W load resistor and output meter to the loudspeaker socket.

Note: A pair of hairpin tongs approximately $\frac{6}{16}$ in long and formed with the ends turned inward and tapered to engage the holes in the end of the slit barrel is very useful in adjusting the optical slit. Such tongs can be made from 20 to 26 gauge music wire or 1/16in diameter drill rod (Picture T).

Ensure emulsion is towards optic slit assembly, then set the volume control at approximately mid-position and start projector. Move slit toward or away from film, as required, to obtain an output reading. Rotate the slit to obtain peak reading and simultaneously move in or out until maximum output is obtained. Tighten slit clamping screw 34 securely to lock the adjustment.

A4.4. BUZZ TRACK ADJUSTMENT

The lateral position of the film in the sound head is controlled by the flanged roller 28 (Figs 13 & 14) and edge guide screw 38. Unless the adjustment

has been disturbed, it is unlikely that screw 38 will require resetting.

Thread the projector with buzz track film and adjust volume control to a suitable listening level. Turn adjusting screw 27 to move flanged roller laterally.

Set the buzz track so that both tones are reproduced at approximately the same volume level. If, after adjustment of guide roller position, signal levels cannot be balanced, or the level of tones fluctuates, adjust edge guide screw 38. If the edge guide screw is far out of adjustment, turn it clockwise until it clears the edge of film, adjust rollers and then set guide screw to stop weave of film.

A5. MAGNETIC HEADS

A5.1. MAGNETIC HEAD WEAR

As wear develops on the magnetic heads, they fail to make good contact with the magnetic stripe, resulting in loss of sound or poor quality sound.

To check for this condition, lace film in the projector and switch on, then gently depress the head platform. This action should transmit movement to the stabilisers if the head is functioning normally. If the stabilisers are unaffected, indicating that wear exists, remove the head and carefully file the tip of the locating stud at the base of the platform until the heads are in contact with the film.

A5.2. TRACKING ADJUSTMENT

The tracking screw permits adjustment of the magnetic heads in the horizontal plane in order to ensure correct head location over the width of the magnetic stripe. To adjust, thread the machine with a full track film, set the selector switch to "magnetic" and with the projector running loosen or tighten the tracking screw as required. A small dental mirror will assist in making a visual examination to ensure that the heads are correctly aligned.

A5.3. HALF-TRACK HEADS

Although these heads are suitably adjusted with a master projector before shipment, you may be required to adjust the skate on the sound head or the magnetic head because the customer's projector may have developed a condition different from that of the master projector.

Mount half-track heads on projector and thread film. Record and play with "inner" and "outer" heads and check for interference between the sound tracks. If evident, it can be adjusted out by the tracking screw on the head.

A6. EXCITER LAMP COVER

A6.1. CHECKING COVER CLEARANCE

Since the film must pass between the sound drum and exciter lamp cover, the clearance between these two components should be checked.

Insert a No. 77 drill or a straight piece of 25 gauge wire into the channel between the drum and cover. Gauge should enter channel with slight friction but without forcing. If clearance is inadequate, straighten the exciter cover locating pins to obtain proper clearance.

A7. MOTOR ADJUSTMENTS

A7.1. PROJECTOR

The speed of the projector is adjustable. Therefore, speed checks should be made for the purpose of determining that the equipment is operating properly and as a means of detecting excessive mechanism loads, damaged drive belt or similar conditions.

A7.1.1. Methods of Measurement. Various devices and procedures can be used to check projector speed. The most common ones (Picture U) are:

Stroboscope or similar strobe light, usually synchronised with interrupter shutter of shuttle, which makes one revolution per frame.

Tachometer, used to measure r.p.m. on the sprocket.

Timed loop of exactly 2400 frames. At sound speed an index mark should pass aperture every 100 seconds, plus or minus 2 seconds. Any convenient multiple of frames can be used.

A7.1.2. Adjustments. Insert a suitable trimmer adjusting tool (Picture W) into the slot of the 18 f.p.s. and 24 f.p.s. trimmers on the printed circuit board and adjust clockwise or counter-clockwise, as required, to obtain correct speeds.

U Methods of Motor Speed Adjustment

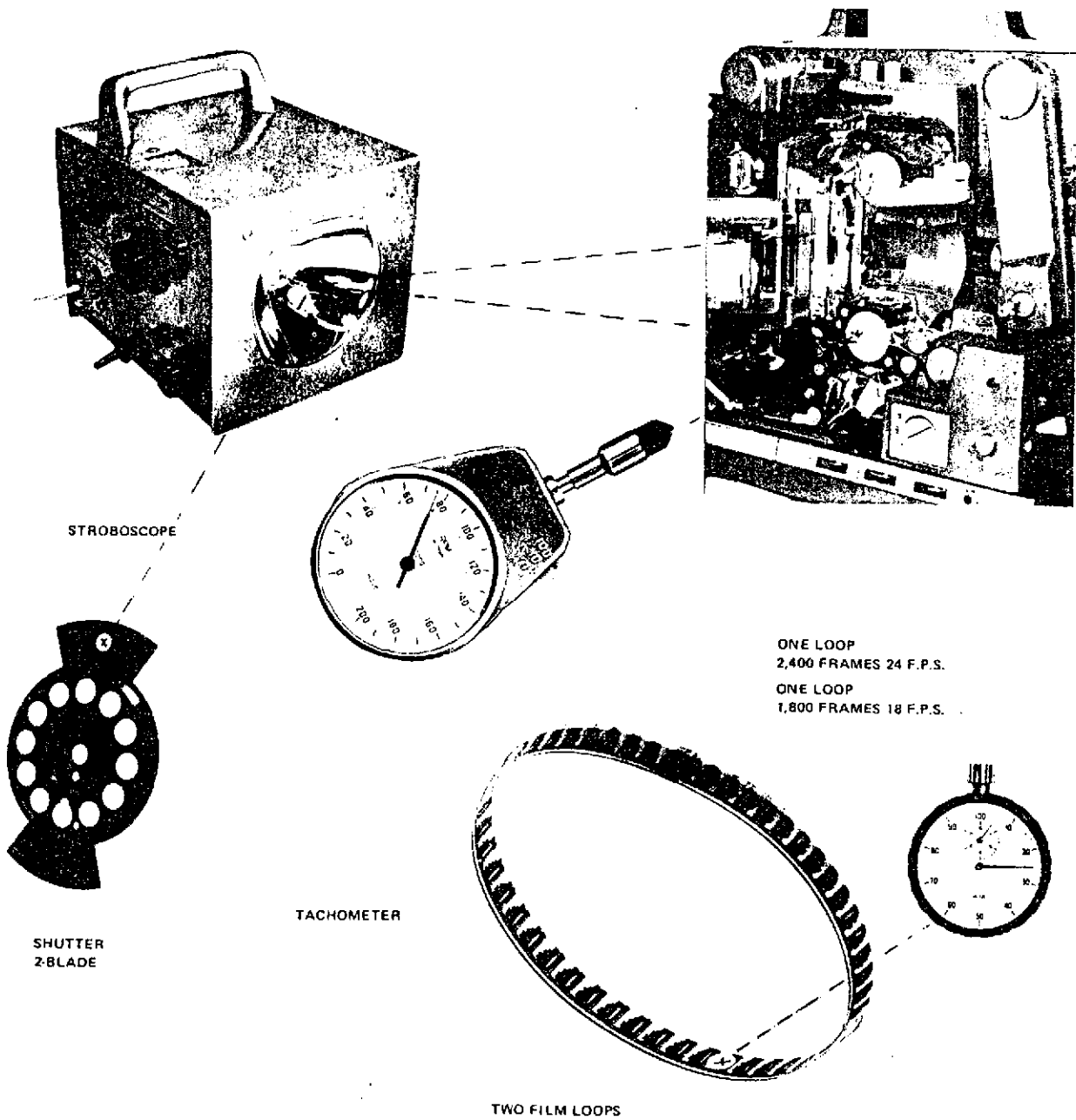

SPEEDS

SOUND SPEED	24 F.P.S. \pm 2%
SHUTTER	2,880 R.P.M. \pm 2%
SPROCKET	102 R. P. M. \pm 2%
SHUTTLE	1,440 R.P.M. \pm 2%
SILENT SPEED	18 F.P.S. \pm 5%
SHUTTER	2,160 R.P.M. \pm 5%
SPROCKET	77 R.P.M. \pm 5%
SHUTTLE	1,080 R.P.M. \pm 5%

2,400 FRAMES COMPLETE ROTATION IN
 100 ± 2 seconds = 24 ± 0.48 F.P.S.

1,800 FRAMES COMPLETE ROTATION IN
 100 ± 2 seconds = 18 ± 0.48 F.P.S.

F.P.S. x 60 = R.P.M. i.e. 24 F.P.S. = 1,440 R.P.M.

A.8. Adjustment of Warning Lamp Circuit

SPECIALIST MODELS ONLY

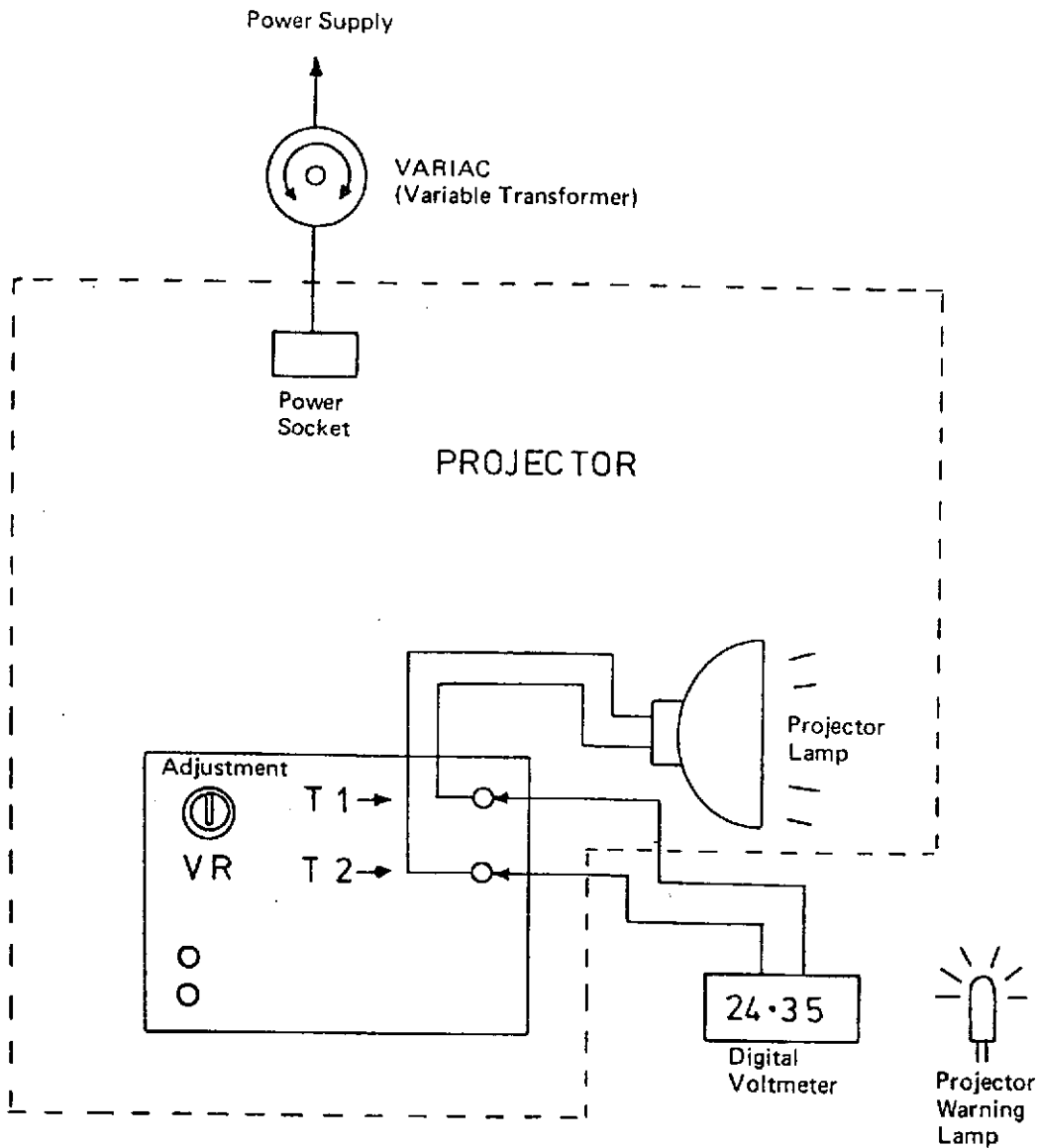

Adjust variable transformer to obtain a reading of 24.35V on digital voltmeter, or similar high accuracy instrument.

Adjust VR to obtain regular flashing of warning lamp.

Set variable transformer to obtain readings of 24.2V and 24.5V. Make fine adjustments to VR until following conditions are met:

Lamp must not flash below 24.2V.

Lamp must flash before 24.5V is exceeded.

Adjustments

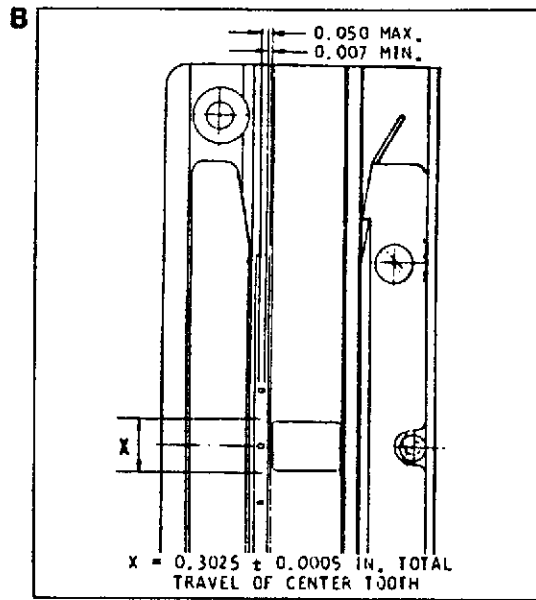
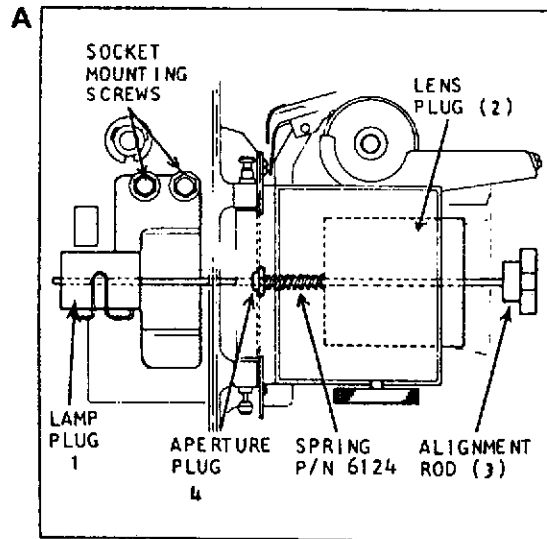

Aperture plate and shuttle tooth clearances

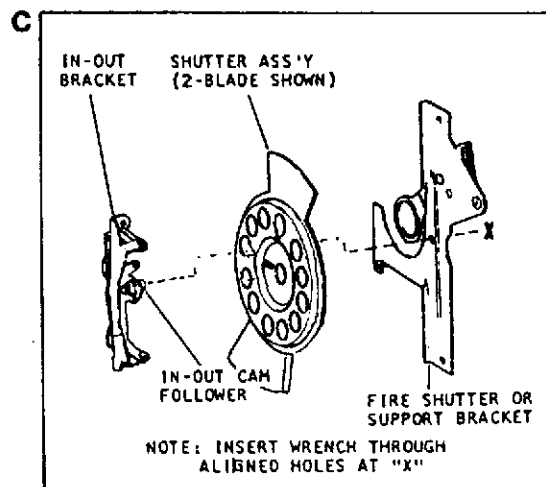

Adjusting Shuttle Tooth Height

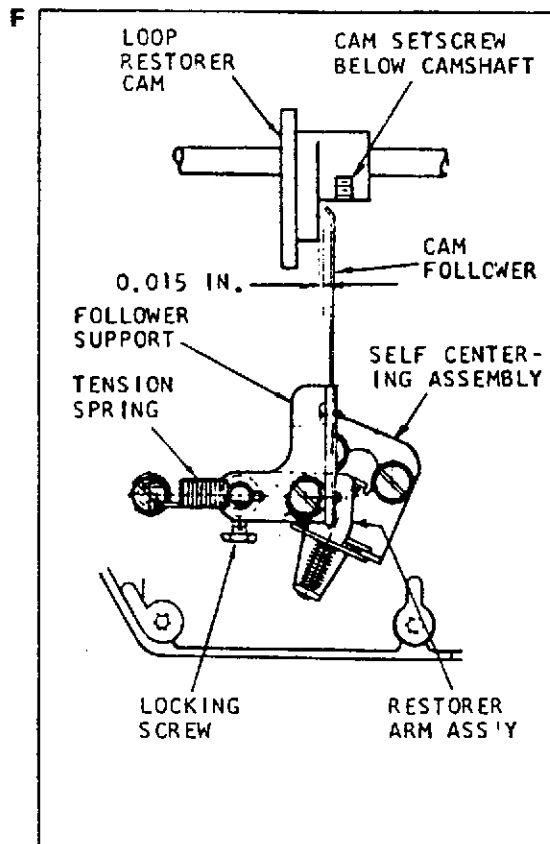
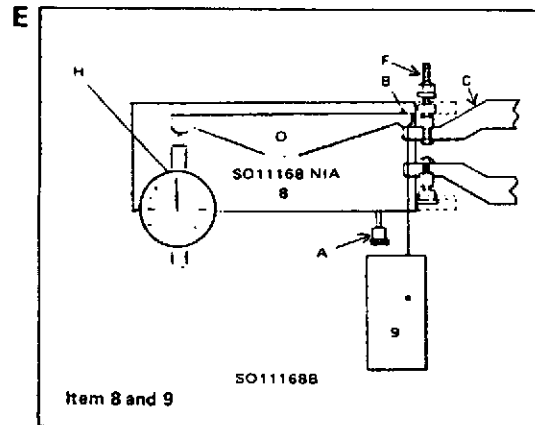
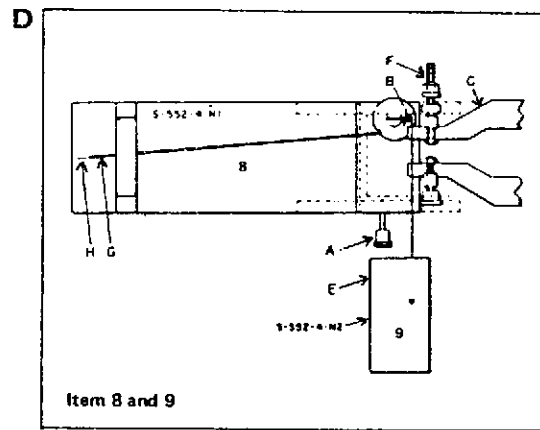

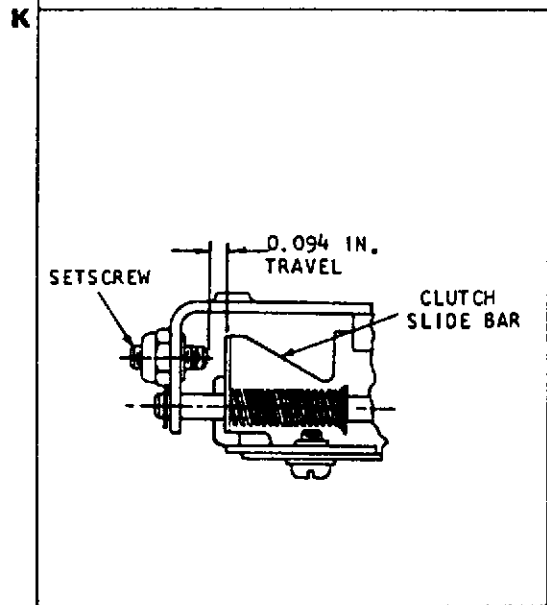
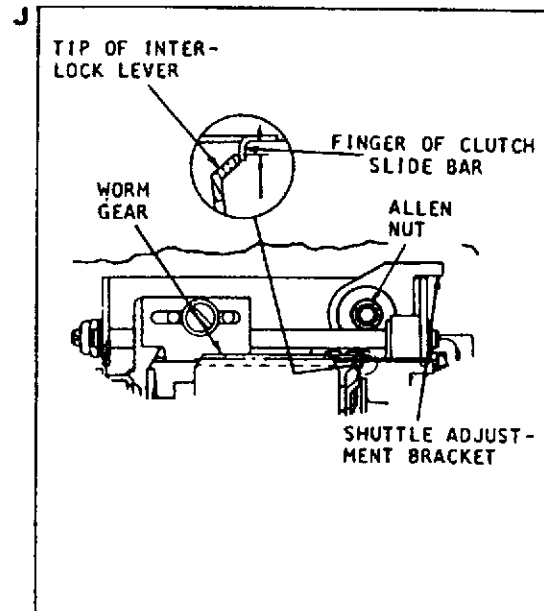
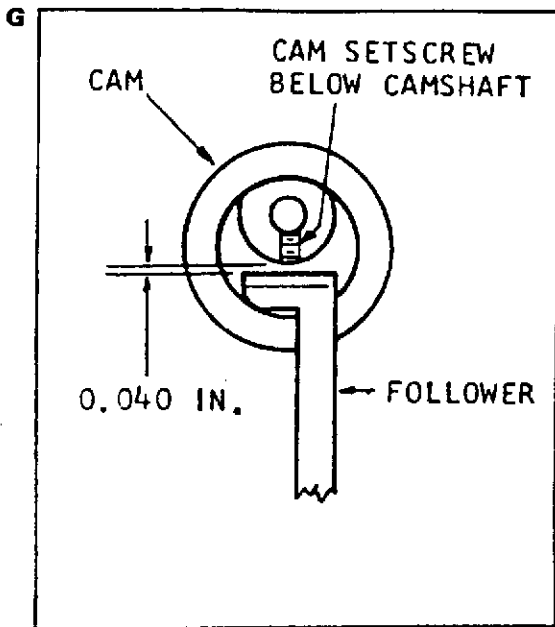

Animation clutch adjustments

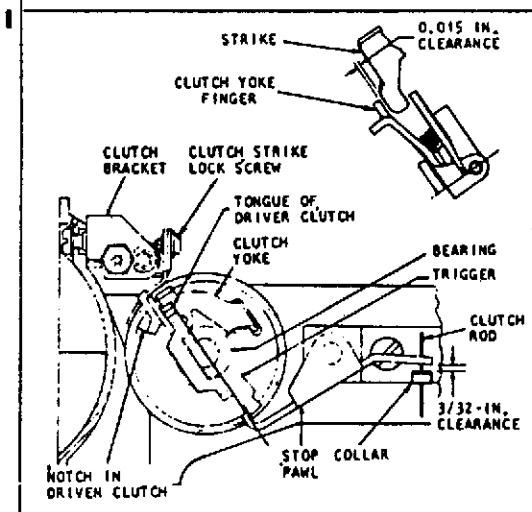
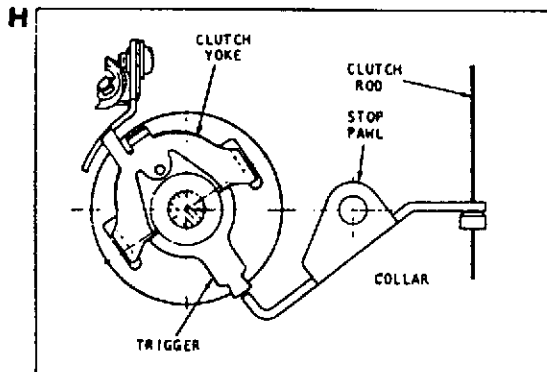

Animation clutch adjustments

Adjustments

L

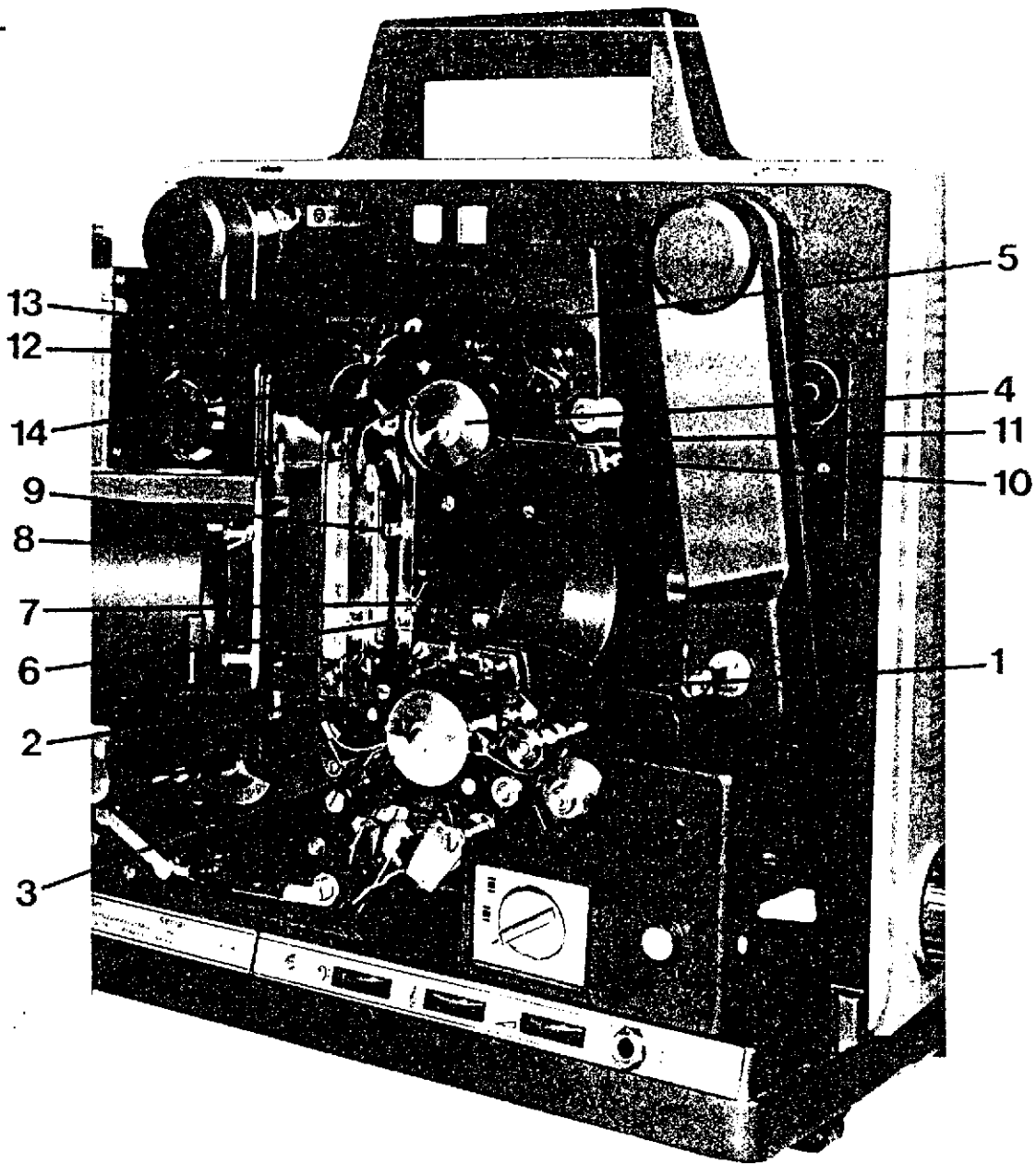

Adjusting the loading guides

- | | | | |
|----|---------------------|-----|-----------------------------------|
| 1. | Guard sprocket | 8. | Pressure plate lever |
| 2. | Screw | 9. | Link and stud assembly connecting |
| 3. | Sprocket assy lower | 10. | Screw |
| 4. | Sprocket assy upper | 11. | Film guide and roller assembly |
| 5. | Lever actuating | 12. | Kickplate and stud assembly |
| 6. | Screws | 13. | Film exit plate |
| 7. | Retractor shuttle | 14. | Loop form assembly |

M Loading guides

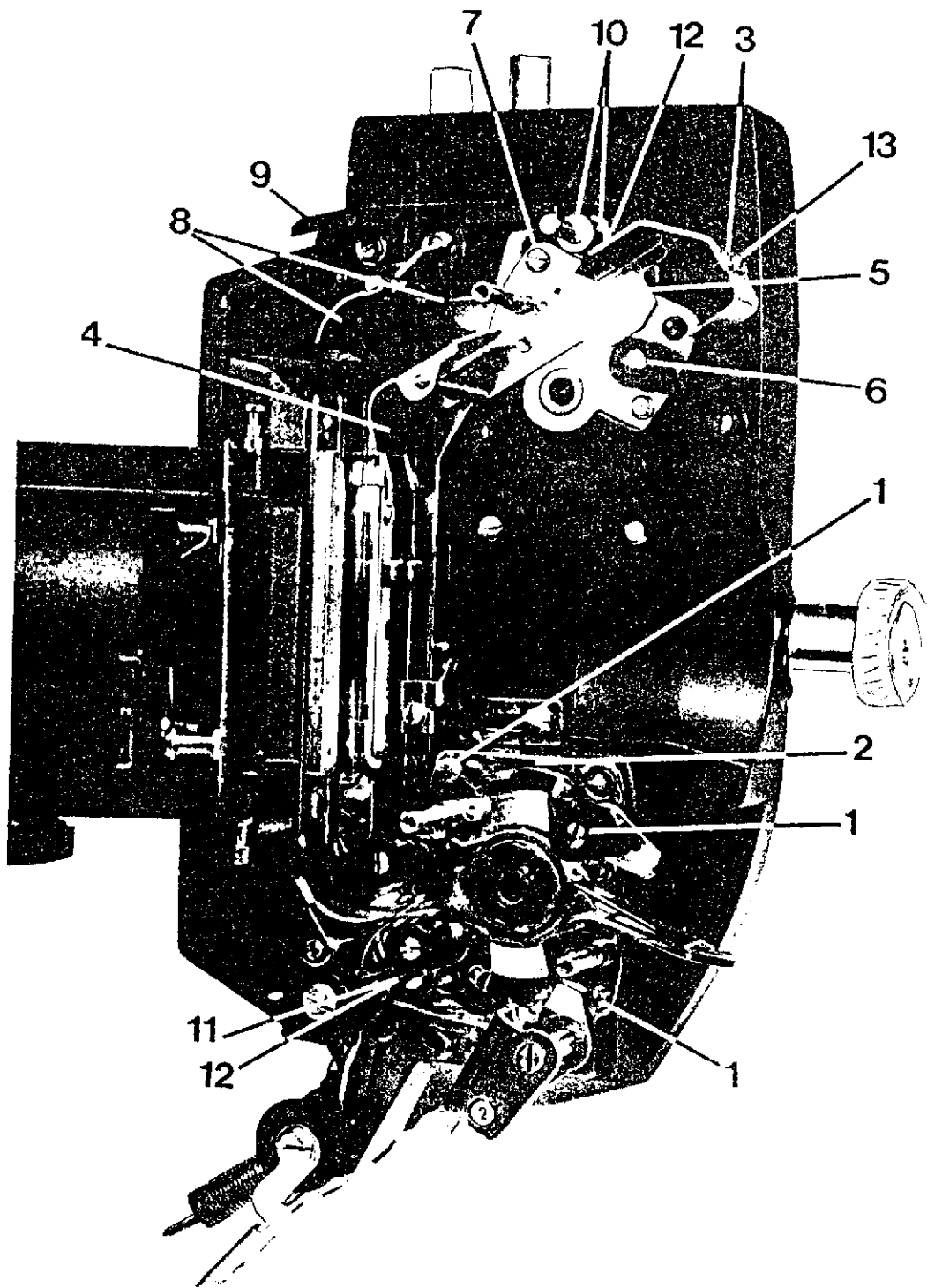

1. Screws
2. Guard mounting plate assembly, lower
3. Screw
4. Lower loop former, upper sprocket
5. Lower loop former assembly, upper sprocket
6. Roller
7. Screws
8. Loop former hub assembly & kickplate
9. Hood
10. Screws
11. Screw
12. Bushing, locking lever
13. Leaf spring

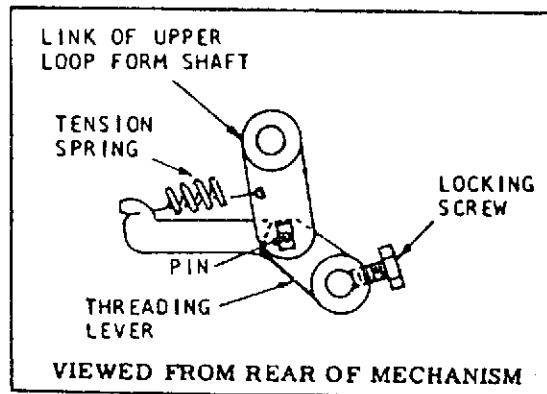

N Auto-thread system adjustments

Adjustments

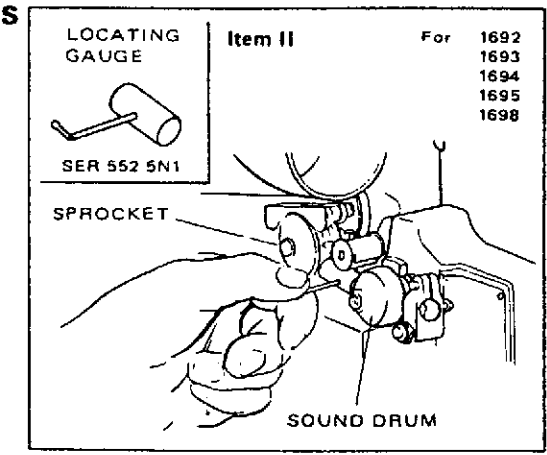
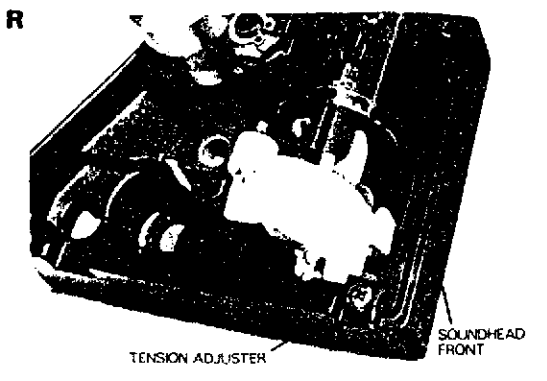
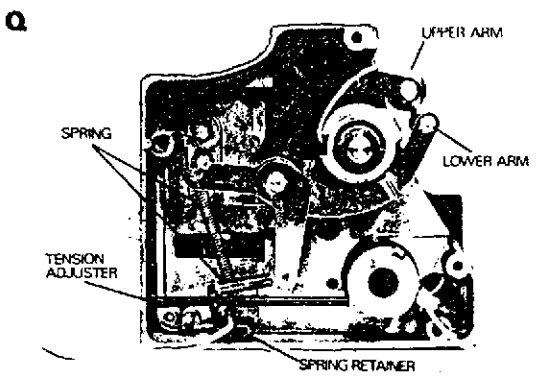
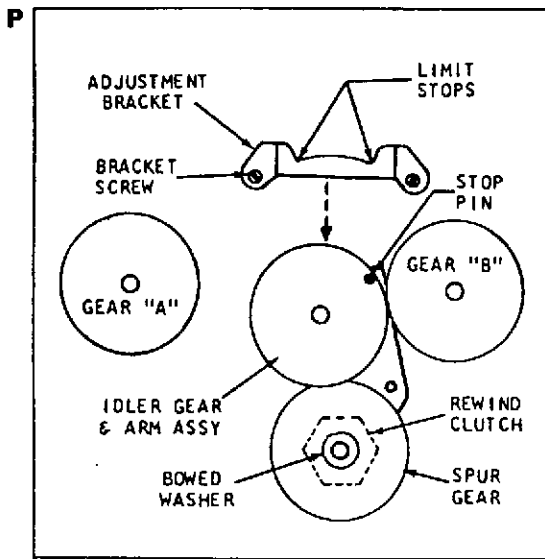
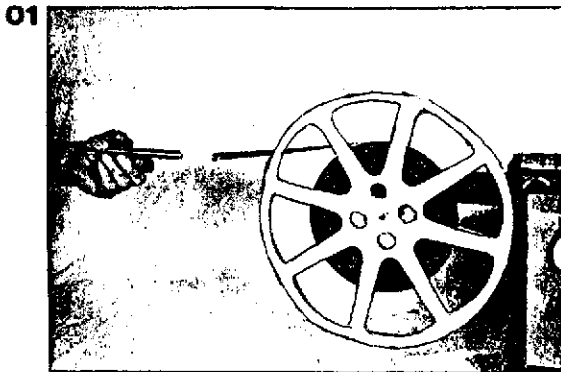
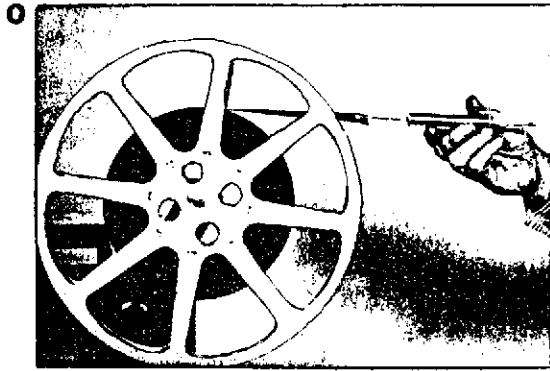

Positioning the Soundhead Assembly

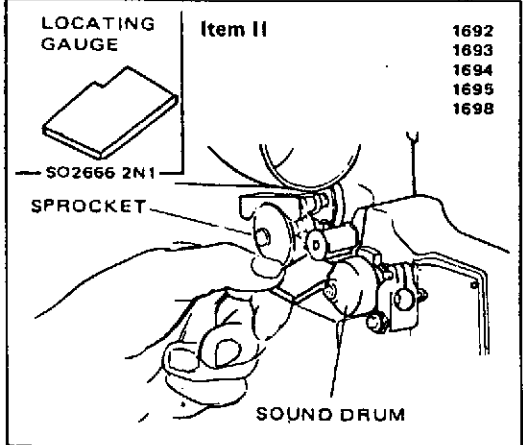

Positioning the Soundhead Assembly

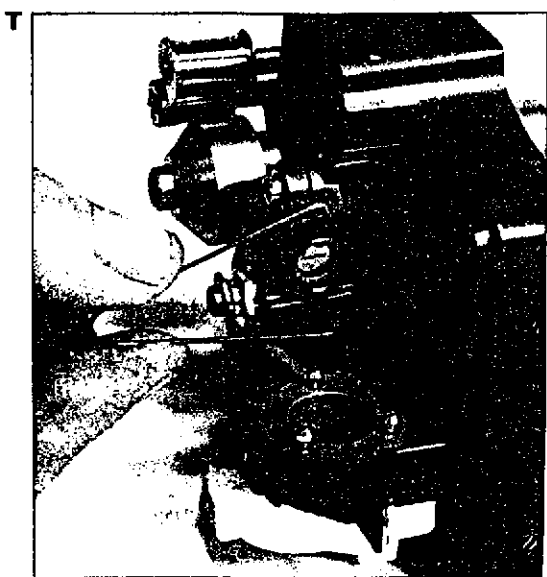

W

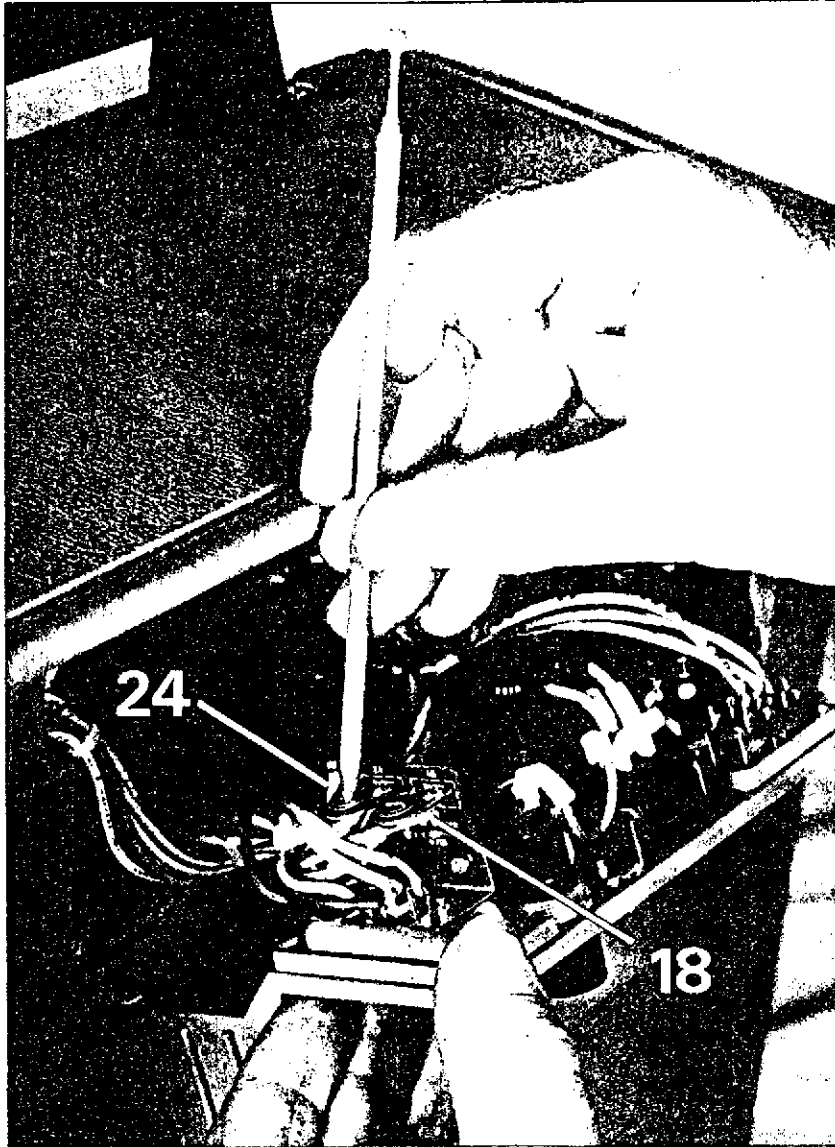

TENSION GAUGES

0 - 1000 GMS

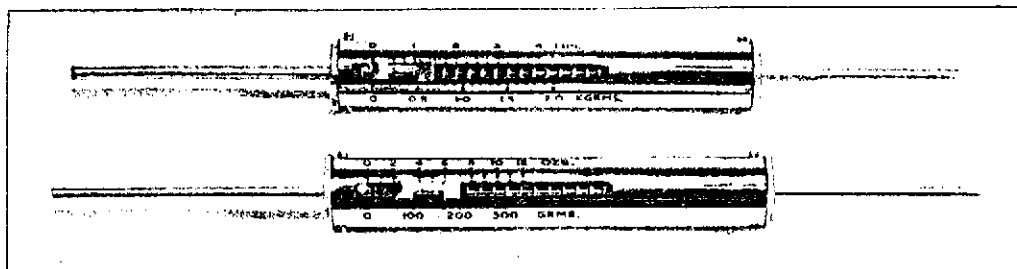

0 - 600 GMS

LIST OF BRISTOL KEYS USED FOR TQIII

<i>Setscrew Part No.</i>	<i>Bristol Handle and Bit</i>	<i>Bristol Bit for Handle</i>	<i>Bristol "L" Bit</i>	<i>Part No. Tool ex B & H U.K.</i>
31050	DS.060	B.060	S.060	2307622
31405				06107
31083				57935
31909	DS.072	B.072	S.072	2307446
36763				
36764				
36765				
434356				
437430				
36769	DS.096	B.096	S.096	2307624
36770				60105
11282				57937
31088	DS.111	B.111	S.111	2307625
				60109
	XCELITE	KEY EXTENSION HANDLE		2307752
				2307751
				2307750
		KIT OF ABOVE THREE PARTS		30167
	ALLEN KEY FOR BLOWER			2307803

TEST FILMS

<i>Test Film Name</i>	<i>Opt Mag</i>	<i>Specifications Recorded with same level as</i>	<i>BHJ Code</i>	
FREQUENCY RESPONSE	7kHz	OPT	ANSI PH 22 44	22
BUZZ TRACK	300Hz-1kHz	OPT	ANSI PH 22 57	37
STEADINESS		OPT	SMPTE ST 16	32
AZIMUTH ALIGNMENT	7kHz	MAG	ANSI PH 114 SMPTE M16AL	42
FLUTTER	3kHz	MAG	ANSI PH 22 113 SMPTE M16FL	50
¼ TRACK INSIDE	3kHz	MAG		110

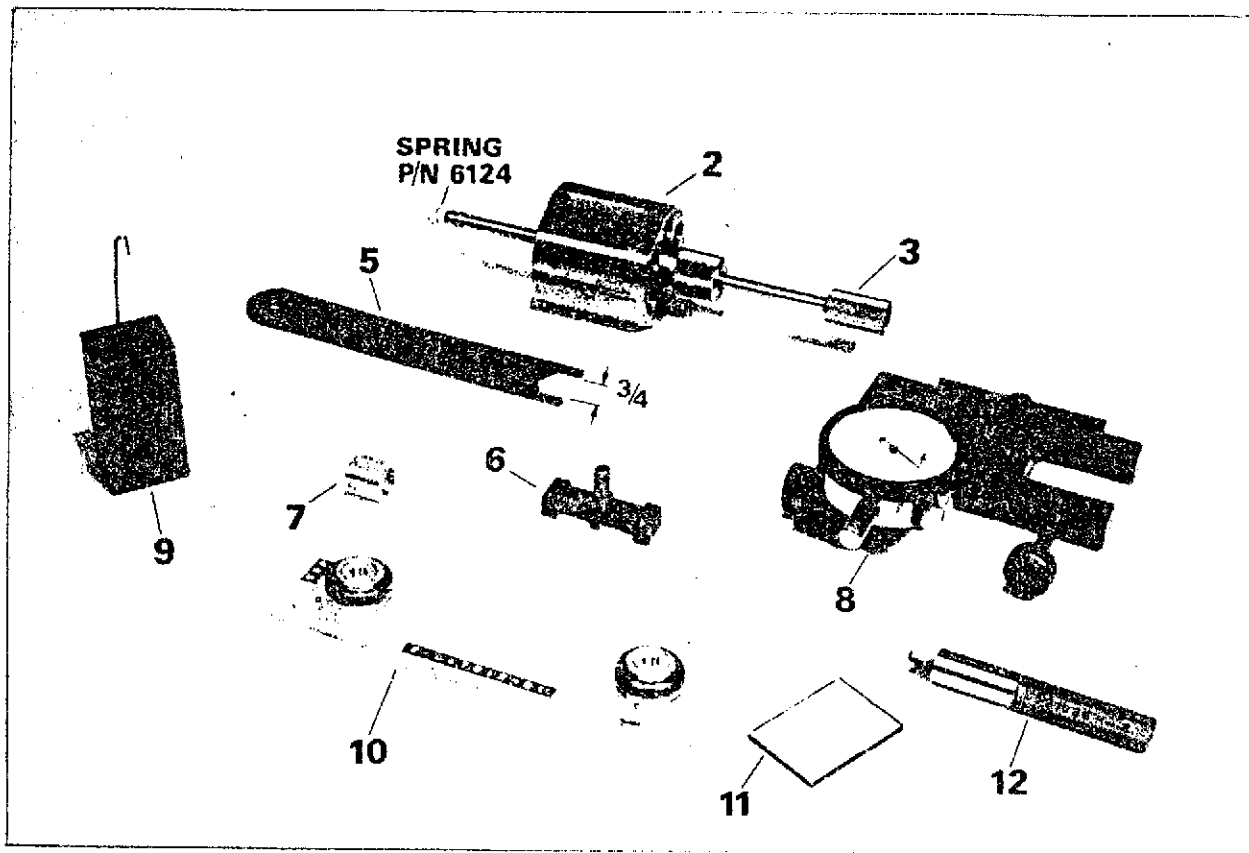

TOOLS – BELL & HOWELL JAPAN

<i>Index No.</i>	<i>BHJ Tool No.</i>	<i>Gauge</i>	<i>Use</i>
2	S026662F 16B	Lens Plug	Alignment of optical system
3	S026662F 16C	Alignment Rod	" " " "
5	Make in Shop	Torque Wrench	Adjust rewind torque (make from 1/16" x 1 1/4" x 7" material)
6	S027101N1	Shuttle Height Gauge	Check shuttle protrusion
7	S550 2N1	Restorer Loop Positioning	Adjusting loop restorer
8	S011168N1A	Shuttle Tension Gauge	Adjusting shuttle tension
9	S011168N1B	Weight for Shuttle Tension Gauge	Adjusting shuttle tension
10	S09701F21	Timing and Alignment Plate	Timing the sprockets
11	S026662N1	Soundhead Locating Gauge	Positioning the soundhead
12	S027025N2	Alignment Gauge	Aligning sound drum and photo cell

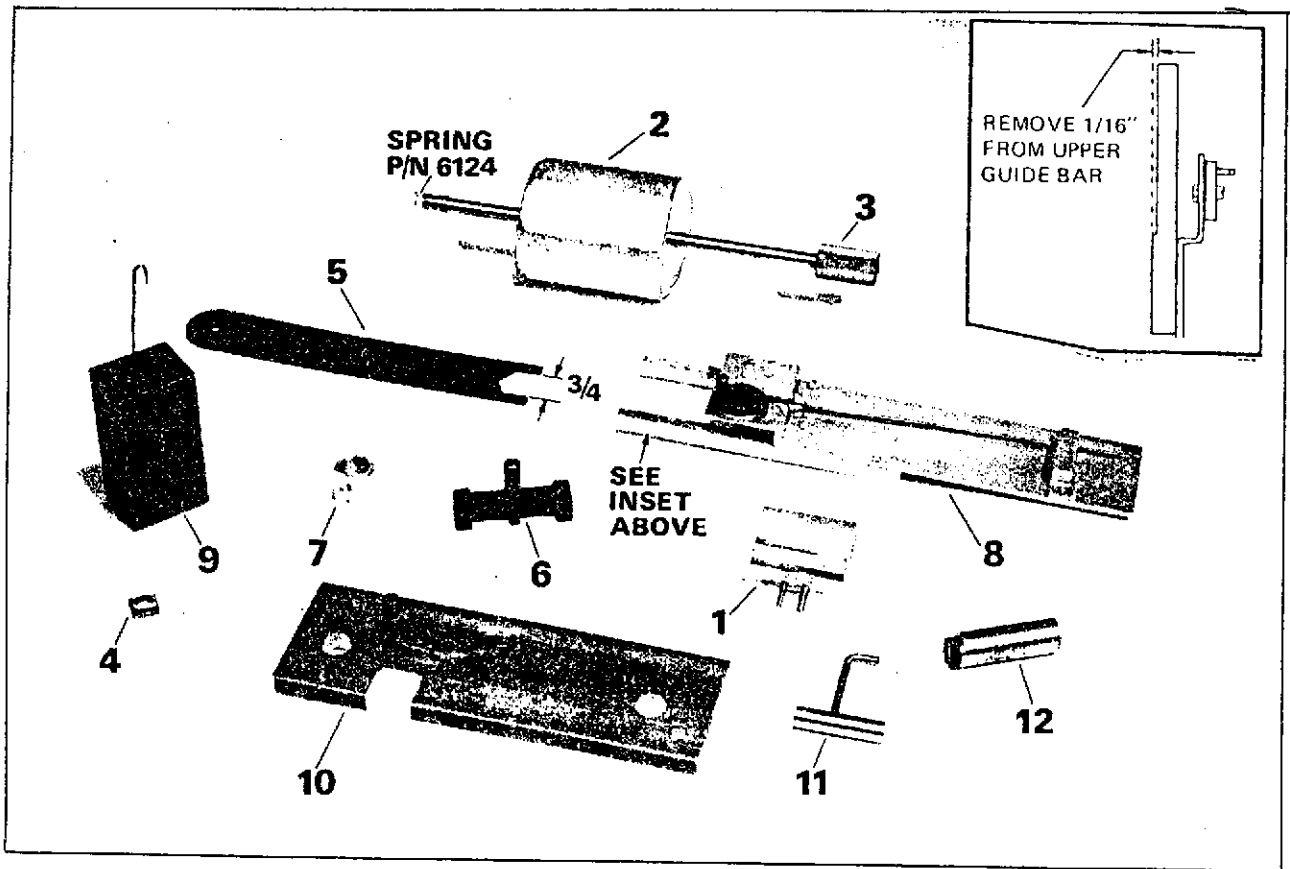

TOOLS -- BELL & HOWELL CHICAGO

<i>Index No.</i>	<i>USA Tool No.</i>	<i>Gauge</i>	<i>Use</i>
1	SER 1552 1N1	Lamp Plug	Alignment of optical system
2	SER 550 2N1	Lens Plug	" " " "
3	SER 550 2N2	Alignment Rod	" " " "
4	SER 9701N13	Aperture Plug	" " " "
5	Make in shop	Torque Wrench	Adjust rewind torque (make from 1/16" x 1 1/4" x 7" material)
6	SER 550 6N1	Shuttle Height Gauge	Check shuttle protrusion
7	SER 552 2N1	Restorer Loop Positioning	Adjusting the loop restorer
8	SER 552 4N1	Shuttle Tension Gauge	Adjusting shuttle tension
9	SER 552 4N2	Weight for Shuttle Tension Gauge	Adjusting shuttle tension
10	SER 552 1N1	Timing and Alignment Plate	Timing the sprockets
11	SER 552 5N1	Soundhead Locating Gauge	Positioning the soundhead
12	SER 550 8N1	Alignment Gauge	Aligning sound drum and photo cell

RECOMMENDED TOOLS

SCREWDRIVERS:

Blade Length (A)		Tip Size (B)	
cm	in	cm	in
7.5	3	3	3/32
7.5	3	6	1/4*
10	4	8	5/16
15	6	10	3/8

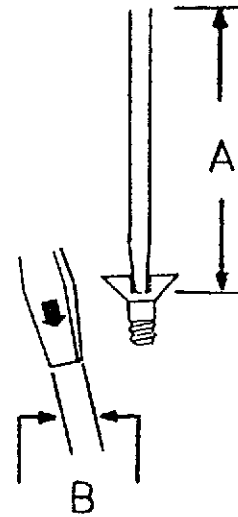

PHILLIPS DRIVERS:

Point Size
0
1*
2*

SCREW AND NUTDRIVER SET: BH PART NUMBER 2307753

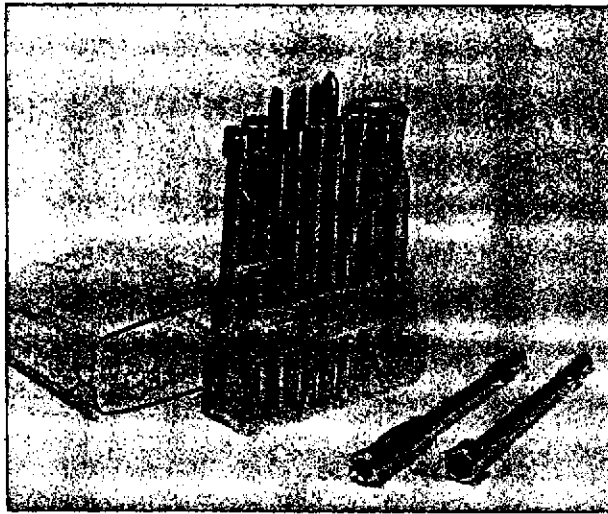

* THESE TOOLS INCLUDED IN ABOVE SET

MECHANISM REMOVAL TOOL

Key 2307752 is designed to fit screw Item 4, Part No. 80167, Figs. 8 - 9.



BH PART: HANDLE ONLY
2307750

EXTENSION ONLY
2307751

KEY ONLY*
2307752

Mounting Bracket for Mechanism TQIII Range

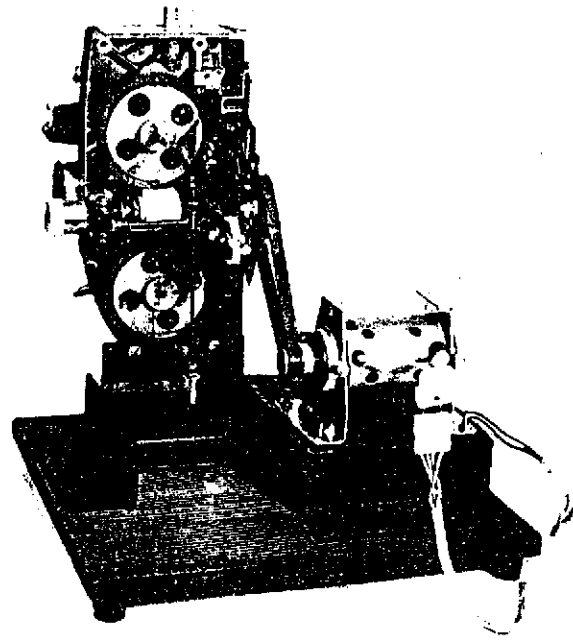
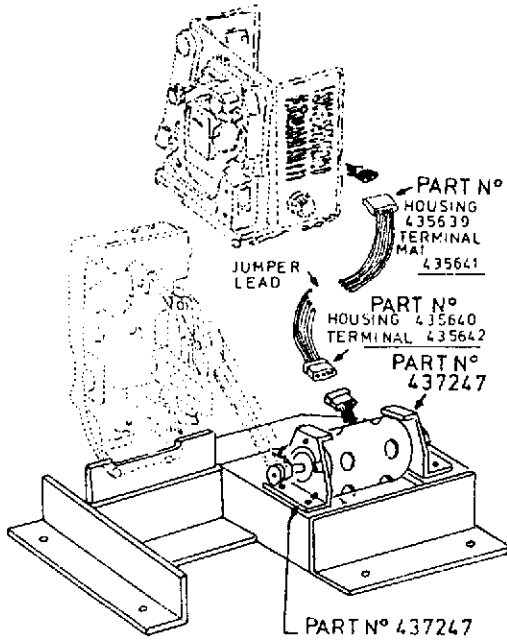

- A. Make up jumper lead using the following:
 Plug Housing: 435639
 Plug Terminal 435641
 Socket Housing 435640
 Socket Terminal 435642
- B. Weld at all points W
- C. Use standard motor and mounting from any projector in the 1600 range.
- D. Use 2BA bolts and nuts as shown in Ref. A to form quick-release mounting for motor/bracket assembly.
- E. Mount on suitable wooden base board.
- F. All measurements in "mm".
- G. All angle iron to be 40 x 40mm approx.

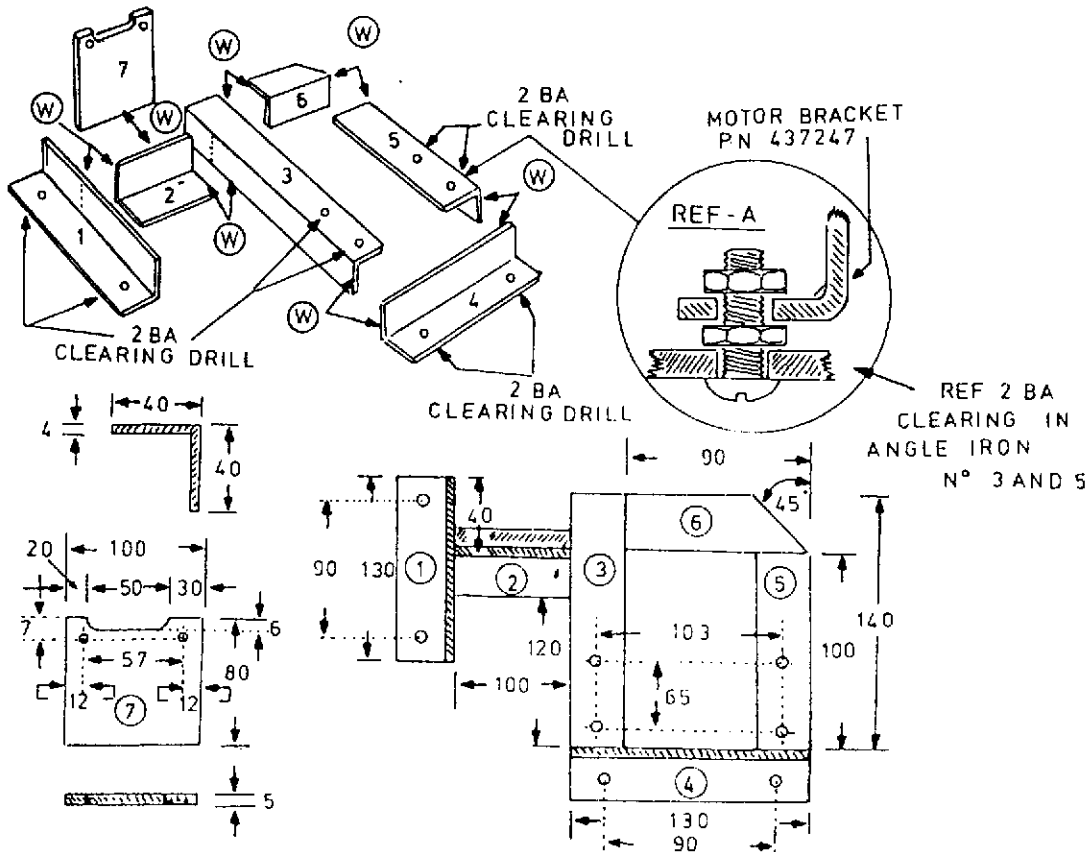

Lubrication Chart

Refer to cleaning and lubrication instructions on page 1 of this manual.

Lubricant	BHJ Spec.	BH USA Spec.	Parts to be lubricated	Local Vendor Information
Shell Oil Turbo 27 Mobil Oil D.T.E. Light Nippon Oil Turbine FBK 90	951J	341	Bearing surfaces of reel arm shafts. Clutch ball retainers. Sprocket shafts.	
Shell Oil Vitrea 73 Nippon Engine Oil FBK 260	1543J	1543	Framer shaft. Bearing face of worm gear. Pin of rewind button. Felt ring in outboard bearing.	
Mobil Oil No. 814		1918	Non-bearing machined surfaces of all castings.	
Shell Clavus No.27 Shell Vitrea 41		1705	All shafts, sleeve bearings and sliding parts (unless otherwise specified).	
Shell Grease Alvania R2 Dow Corning Molykote LTN2 Caltex Oil Regal Nippon Oil Regal Starfak No.2	1956J	1956	Tilt rack and pinions. Meshing gears in reel arms. Reel arm release mechanisms. Friction surface of lamp release ring. In-out cam and cam follower. Shuttle link bearings. All nylon gears. Cam wiper and wick. Pivot posts for all film guides. Upper and lower sprocket bearings. Shuttle guide and guide bearings. Loop restorer and self-centering assembly. Pin of take-up drive sprocket assembly. Threads of frame shaft. All diameters of cam shaft bearing holes. Teeth of focus knob pinion. Worm gear.	

TROUBLE	PROBABLE CAUSE	REMEDY
Nothing operates.	1. Defective mains cord.	Repair or replace.
	2. Main fuse failed.	Replace fuse F101.
	3. Power switch defective.	Replace.
	4. Loose connections.	Rectify.
Projector motor does not run; all other functions normal.	1. No DC voltage to motor.	Check fuse F301. Isolate defective components or connections and rectify.
	2. Main function switch S103 defective	Replace.
	3. Faulty component or open-circuit connection on speed control PCB.	Isolate and correct.
	4. Defective motor servo IC.	Replace.
	5. Motor defective.	Replace.
Projector motor runs in one direction only.	1. Open-circuit connection.	Rectify.
	2. Main function switch S103 defective.	Replace.
Projector motor runs but mechanism does not run.	1. STOP/RUN switch in STOP mode.	Select RUN mode.
	2. Drive belt broken.	Replace.
	3. Motor pulley loose on shaft.	Tighten.
	4. Mechanism jammed.	Rectify.
	5. Damaged switch.	Replace switch.
	6. Transposed leads on switch.	Connect leads to proper terminals.
	7. Animation clutch spring broken.	Replace spring.
Rewind does not operate.	1. Rewind clutch not engaging or clutch slipping.	Adjust.
Feed spindle does not operate.	1. Dirt in reverse take-up clutch.	Clean clutch.
Gate will not lock.	1. Latch spring set to close to lens mount stop.	Adjust latch spring.
	2. Pressure plate out-of-line.	Realign pressure plate.
Shuttle runs but sprockets do not revolve.	1. Animation clutch spring broken or lost.	Replace spring.
Projector lamp - short life. *Note: Where fitted, over-volt warning will flash to indicate this symptom.	1. Excessive supply voltage.*	Adjust voltage selector to match supply.
	2. Blower defective.	See Blower section and rectify.
	3. Dirt and lint clogging blower housing.	Clean.
Projector lamp not functioning.	1. Faulty connections at socket, switch S103 or transformer.	Isolate and rectify.
	2. Main function switch defective.	Replace.
Frame speeds incorrect.	1. Motor drive belt slipping.	Fit new belt.
	2. Motor pulley loose.	Tighten.
	3. Defective motor servo IC.	Replace.
	4. Incorrect speed control adjustment.	Adjust RV701 (18 fps), RV702 (24 fps), A7.
	5. Mechanism binding.	Check with inching control and rectify.

TROUBLE	PROBABLE CAUSE	REMEDY
Blower does not run.	1. If exciter lamp does not light . . .	Replace fuse F304.
	2. No DC voltage to motor.	Isolate defective components or connections and rectify.
	3. Main function switch S103 defective.	Replace.
	4. Impeller loose on shaft.	Tighten.
	5. Motor defective.	Replace.
Animation clutch does not operate.	1. Solenoid plunger set too high or too low.	Adjust solenoid plunger. A3.4.2.
	2. Stop pawl clearance excessive.	Adjust. A3.4.2.
Animation clutch stops sprocket but shuttle pulls film.	1. Insufficient shuttle retraction.	Adjust. A3.3.
Splices jam in sprocket shoes.	1. Bad splices.	Replace splices.
	2. Emulsion build-up.	Clean film path components.
No optical sound, projector runs, exciter lamp lights.	1. Function switch in REVERSE mode.	Select FORWARD mode.
	2. Mag/Opt switch in Mag mode.	Select Opt mode.
	3. Open-circuit speaker or leads.	Replace or rectify.
	4. Speaker socket faulty.	Replace.
	5. Amplifier circuit defective.	Isolate cause of failure and rectify.
	6. Sound optics obscured by dirt.	Clean.
	7. Speaker socket switch defective.	Replace or repair.
	8. Microphone socket switch defective.	Replace or repair.
Exciter lamp does not light.	1. Faulty exciter lamp.	Replace.
	2. If blower does not run . . .	Replace fuse F304
	3. if amplifier circuit does not operate . . .	Replace fuse F302/303.
	4. Open-circuit voltage stabilizer transistor.	Replace.
	5. Short-circuit zener diode.	Replace
	6. Open-circuit resistor.	Replace.
	7. Defective lamp socket connections or wiring.	Repair or replace.
Exciter lamp fails consistently.	1. Defective voltage stabiliser circuit.	Isolate defective component and rectify.
Low optical volume or distortion.	1. Buzz track misaligned.	Realign.
	2. Optical slit misaligned.	Realign.
	3. Sound optics obscured by dirt.	Clean.
	4. Photo diode defective.	Replace.
	5. Amplifier defective.	Isolate fault and rectify.
	6. Wrong exciter lamp used.	Replace with correct lamp.
Crackling noises.	1. Optical film track scratched.	Change film.
	2. Broken or loose ground connections to main frame.	Isolate and rectify
	3. Loose connections in amplifier.	Isolate and rectify.
	4. Noisy amplifier component.	Isolate and replace.
	5. Broken cable shield.	Isolate and repair.
	6. Buzz track out of line.	Realign.

TROUBLE	PROBABLE CAUSE	REMEDY
Wow or flutter.	1. Soundhead stabilizer guide roller sticking.	Clean roller and roller shaft.
	2. Stabiliser guide roller spring broken, unhooked or lost.	Repair or replace spring.
	3. Film edge guide (soundhead) out of line.	Realign.
	4. Loose flywheel.	Tighten flywheel.
	5. Damaged sound drum bearing.	Replace sound drum.
	6. Dirt causing guide roller arm pivot bearing to bind.	Clean and polish.
	7. Photocell or exciter lamp cable rubbing against flywheel.	Reposition cables.
	8. Chips or dirt in take-up sprocket gear teeth.	Remove and clean sprocket gear.
	9. Roller arm not stabilising.	Adjustment. A4.
Film cannot be inserted into feed sprocket	1. Obstruction below roller of channel 29 (Fig.15).	Remove obstruction.
	2. Channel bent or binding.	Straighten or replace assembly.
	3. Excessive pressure on leaf spring.	Adjust leaf spring. A3.6.
Film will not run between feed sprocket and sprocket shoe.	1. Entrance guide 11 (View L) misaligned.	Realign. A3.6.
	2. Feed sprocket guard sticking.	Clean sprocket shoe pivot.
	3. Feed sprocket guard spring broken.	Replace spring.
	4. Caked emulsion or burr on sprocket shoe film rails.	Clean: remove burr with crocus cloth.
Film comes out the side of top sprocket.	1. Obstruction in sprocket guard.	Remove obstruction.
	2. Damaged sprocket guard.	Replace sprocket shoe.
	3. Sprocket guard and sprocket misaligned laterally.	Realign.
Film strikes top of aperture plate and begins to pile up.	1. Upper loop former 8 (View M) bent or out of adjustment.	Straighten or replace if bent; or readjust. A3.6.
	2. Lower loop former 4 (View M) set too close to aperture plate.	Readjust. A3.6.
Film butts into or goes under top end of aperture plate side tension fixed rail.	1. Upper loop former 8 (View M) bent, causing sidewise deflection of film.	Straighten or replace.
	2. Lower loop former 4 (View M) bent or out of adjustment.	Straighten or replace if bent; or readjust. A3.6.
Film butts against top of film pressure plate or passes over outside of pressure plate.	1. Lower loop former 4 (View M) out of adjustment.	Readjust. A3.6.
	2. Pressure plate not lifting off aperture plate when gate is closed.	Bent parts need straightening or replacing. A3.6.
Film ejects between bottom of gate and top of take-up sprocket, or piles up in this area.	1. Lower loop former 13 (Fig. 16) bent or sticking.	Straighten, release, or replace as necessary.
	2. Lower loop former spring 14 (Fig. 16) broken.	Replace spring.
	3. Loop restorer out of adjustment or restorer roller stud bent.	Readjust loop restorer or replace damaged parts. A3.1.
	4. Obstruction or burr in take-up sprocket upper guard.	Clean: remove burr with crocus cloth.
	5. Sprockets out of time.	Time sprockets. A3.2.

TROUBLE	PROBABLE CAUSE	REMEDY
Film not threading over take-up sprocket.	<ol style="list-style-type: none"> 1. Sprocket guard mounting plate 22 (Fig. 16) out of position. 2. Obstruction in upper sprocket guard. 3. Sprocket guard spring 50 (Fig.15) broken. 4. Take-up sprocket shaft loose in gear 26 (Fig. 15). 	<p>Reposition.</p> <p>Remove obstruction.</p> <p>Replace spring.</p> <p>Retime sprockets (A3, 2) and tighten setscrews 25, 39.</p>
Film piles up ahead of sound drum.	<ol style="list-style-type: none"> 1. Insufficient clearance between sound-head threading guides 19 and 25 (Fig. 16). 2. Back-up bracket 16 (Fig. 16) bent downward. 3. Exciter lamp cover loose. 4. Obstruction in gap between sound drum and exciter lamp cover. 5. Not enough clearance between sound drum and cover. 6. Wrong setting of guide adjusting screw 38 (Figs. 13, 14). 	<p>Readjust all guides. A3.6.</p> <p>Straighten bracket.</p> <p>Tighten cover retaining screw.</p> <p>Remove obstruction.</p> <p>Check clearance.</p> <p>Adjust.</p>
Film ejects ahead of lower take-up sprocket shoe or piles up in this area.	<ol style="list-style-type: none"> 1. Insufficient clearance between sound-head threading guides 19 & 25 (Fig. 16). 2. Sound head loose or improperly positioned. 3. Obstruction or burr in lower take-up sprocket guard. 4. Film guide 6 (Figs. 13, 14) improperly positioned. 	<p>Readjust all guides. A3.6.</p> <p>Reposition.</p> <p>Remove obstruction; remove burr with crocus cloth.</p> <p>Reposition guide.</p>
Film sticks in or is ejected from lower take-up sprocket guard.	<ol style="list-style-type: none"> 1. Obstruction or burr in lower take-up sprocket guard. 2. Sprocket guard sticking. 3. Broken sprocket guard spring 50 (Fig. 15). 4. Sprocket guard and sprocket misaligned laterally. 5. Autothread lever 11 (Fig. 16) bent or improperly positioned. 	<p>Remove obstruction; remove burr with crocus cloth.</p> <p>Clean sprocket guard pivot.</p> <p>Replace spring.</p> <p>Realign.</p> <p>Reposition or straighten lever.</p>
Film piles up ahead of idler roller or is ejected from this area.	<ol style="list-style-type: none"> 1. Autothread lever 11 (Fig. 16) bent or improperly positioned. 2. Idler roller sticking or roller stud loose or bent. 	<p>Repair or replace lever.</p> <p>Remedy sticking condition; replace autothread lever.</p>
System will not lock.	<ol style="list-style-type: none"> 1. Autothread lever 11 (Fig. 16) binding. 2. Release spring 10 (Fig. 16) disengaged or broken. 3. Eccentric bushing 9 (Fig. 16) improperly adjusted. 	<p>Repair or replace lever.</p> <p>Engage spring with locking lever or replace spring.</p> <p>Readjust bushing.</p>
Loop restorer cycles continuously.	<ol style="list-style-type: none"> 1. Restorer out of adjustment. 2. Shuttle retractor pin 36 (Figs. 17, 18) sticking. 3. Pressure plate 7 (Fig. 15) binding on aperture plate edge guide. 	<p>Adjust. A3.1.</p> <p>Clean and lubricate.</p> <p>Realign pressure plate.</p>
Slack film in sound head area.	<ol style="list-style-type: none"> 1. Sprocket guards sticking. 2. Take-up jerking. 	<p>Clean sprocket shoe pivots.</p> <p>Check take-up torque and check for binding in take-up reel arm.</p>

TROUBLE	PROBABLE CAUSE	REMEDY
Slack film in sound head area. (cont.).	3. Jockey rollers (sound head) sticking.	Clean and lubricate.
	4. Sound head improperly positioned.	Reposition. A4.2.
	5. Dirt or obstruction between sound drum and exciter lamp cover.	Remove obstruction.
Film scratched.	1. Caked emulsion in film path.	Clean film path.
	2. Film chips in sprocket guards.	Remove film chips.
	3. Scratches or burrs on film guides, guards, apertures or pressure plate.	Polish with crocus cloth or replace.
	4. Jockey rollers (sound head) sticking.	Clean and lubricate.
Perforations strained or torn.	1. Shuttle not retracting.	Adjust. A3.6.
	2. Pressure plate not lifting from aperture plate.	Adjust. A3.6.
	3. Excessive feed or take-up tension.	Adjust tension.
Film "embossed" between perforations.	1. Sprocket shoes sticking.	Clean sprocket shoe pivots.
	2. Shuttle not retracting.	Adjust. A3.6.
	3. Sprockets out of time.	Retime. A3.2.
	4. Inadequate pressure on leaf spring 27 (Fig. 16).	Adjust. A3.6.
	5. End of film leader not cut clean and square.	Check film cutter, replace if dull or broken.
Film escape mechanism does not open to permit exit of film.	1. Film exit latching is out of adjustment.	Readjust. A3.6.
Film escape locking pawl not seated properly; film exits constantly.	1. Torsion spring 50 (Fig. 16) disconnected.	Connect torsion spring.
Picture unsteady.	1. Damaged film.	Repair or replace.
	2. Loose shuttle.	Adjust and tighten.
	3. Dirt in picture gate.	Clean.
	4. Damaged or lost pressure plate spring.	Replace spring.
	5. Pressure plate misaligned.	Realign pressure plate.
Double image.	1. Excessive shuttle protrusion.	Adjust. A2.1.
Picture weaves.	1. Sticking edge guide.	Clean guide.
	2. Tension spring missing.	Replace spring.
	3. Fixed edge guide out of position.	Reposition guide.
Poor illumination.	1. Optics out-of-line.	Realign. A1.
	2. Fire shutter sticking.	Check mechanical linkage for binding.
	3. Defective lamp.	Replace lamp.
Poor focus.	1. Dirty lens.	Clean lens.
	2. Warped film.	Recondition or replace film.
	3. Projector lens mount out-of-line.	Realign. A1.
	4. Pressure plate spring missing.	Replace spring.
	5. Bent pressure plate.	Replace pressure plate.
	6. Pressure plate out-of-line.	Realign pressure plate.

TROUBLE	PROBABLE CAUSE	REMEDY
Insufficient framing range.	1. Framer eccentric out of adjustment.	Adjust. A2.1.4.
Travel ghost.	1. Shutter out-of-line.	Reassemble properly.
Loss of loops.	1. Damaged film. 2. Inadequate shuttle protrusion. 3. Inadequate or excessive shuttle stroke. 4. Pressure plate spring missing. 5. Pressure mounting plate screws loose. 6. Sprocket guards not closing. 7. Sprocket drive gear loose on shaft. 8. In-out bracket spring broken.	Repair or replace film. Adjust. A2.1. Adjust. A2.1.4. Replace spring. Tighten mounting screws. Clean or adjust. Retime and tighten screws. A3.2. Replace spring.
Shuttle operates but sprockets do not revolve.	1. Animation clutch spring broken or missing.	Replace spring.
Lower loop not restoring.	1. Loop restorer stroke too short. 2. Loop restorer does not engage restorer cam.	Adjust. A3.1. Adjust. A3.1.
Film rubs on loop restorer roller.	1. Restorer arm out of position.	Reposition. A3.1.
Excessive film noise from gate.	1. Damaged film. 2. Green film. 3. Dirty pressure plate. 4. Pressure plate rubbing on aperture plate guide rails. 5. Incorrect shuttle stroke.	Recondition or replace. "Age" or lubricate film. Clean pressure plate. Realign pressure plate. Adjust.
Animation and STOP/RUN solenoids not operating.	1. No DC voltage to solenoids.	Check fuse F305. Isolate defective components, switches or connections and rectify.
Rhythmic clicks.	1. Dirt on sound drum.	Clean.
Loss of high frequencies or high frequencies fade.	1. Optical slit misaligned. 2. Warped film. 3. Dirt on film. 4. Film edge on sound head misaligned. 5. Dirt on sound drum.	Realign. No remedy. Clean. Realign. Clean.
Hum.	1. Earth loop in amplifier circuit. 2. Defective electrolytic capacitor in power supply. 3. Amplifier shielding not grounded. 4. Defective amplifier component. 5. Test equipment causing earth loop, or not at same potential as amplifier.	Isolate and rectify. Isolate and replace Rectify. Isolate and rectify. Operate test equipment from isolating transformer.

TROUBLE	PROBABLE CAUSE	REMEDY
No magnetic sound; optical sound functioning.	1. Function switch in reverse mode.	Select forward mode.
	2. Mag/Opt switch in optical mode.	Select magnetic mode.
	3. Magnetic head incorrectly seated on contacts.	Adjust.
	4. Magnetic head open-circuit.	Replace.
	5. Magnetic pre-amplifier defective.	Isolate cause of failure and repair.
Magnetic sound - low volume or poor quality.	1. Film warped or magnetic stripe damaged.	No remedy.
	2. Film edge guide on sound drum misaligned.	Realign.
	3. Magnetic head alignment incorrect.	Adjust.
	4. Magnetic head worn or defective.	Replace.
	5. Magnetic pre-amplifier defective.	Isolate cause and repair.

Trouble shooting: auto-thread system

GENERAL

Any obstruction in the film path, such as caked emulsion, film chips or splicing tape, can be expected to interfere with proper threading. Time will be saved by cleaning the threading path and making a visual inspection of all shoes and guides before attempting to localize the trouble.

Do not use metal tools to remove material adhering to guides or rollers. Use an orange stick, plastic rod or toothpick whenever scraping is necessary. Pipe cleaners dampened with toluol, naphtha or isopropyl alcohol are very convenient for cleaning in restricted areas. Do not use trichlorethylene or carbon tetrachloride as cleaning solvents as they might damage or stain plastic parts. Excessive amounts of solvent should not be used because lubricants will be removed from linkage pivots, slides, etc., and will have to be replenished.

FILM CONDITION

The auto-thread system has been designed to function properly with all films which can be described as being in projectable condition. Generally, any film which functions properly in other Bell & Howell 16mm projectors can be used for testing the auto-thread system. Any film which does not thread properly should be inspected. The end of the leader must be properly trimmed and free from sharp bends. All sprocket holes in the first 18 inches of leader must be in good condition. Splices must be properly registered and in good condition. Sprocket holes restricted by cement or splicing tape must be cleared or the splice remade. The repairman is cautioned that it would be a waste of time to adjust or attempt to adjust the auto-thread system to thread a film which is in such poor condition as to be incapable of being the source of an uninterrupted film presentation of acceptable quality.

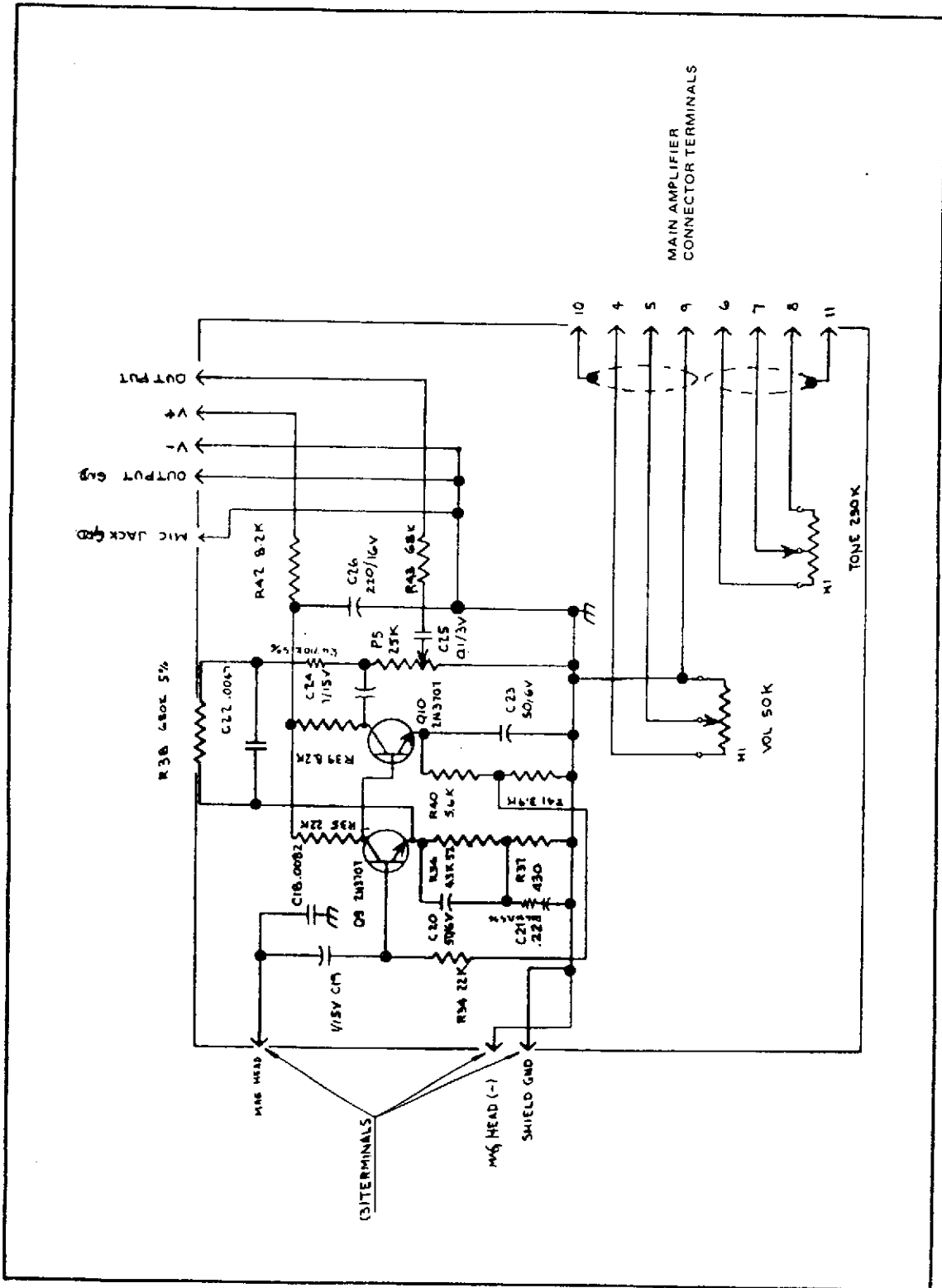

Figure 23. Circuit Diagram Tone / Volume Control Board Des. 1693

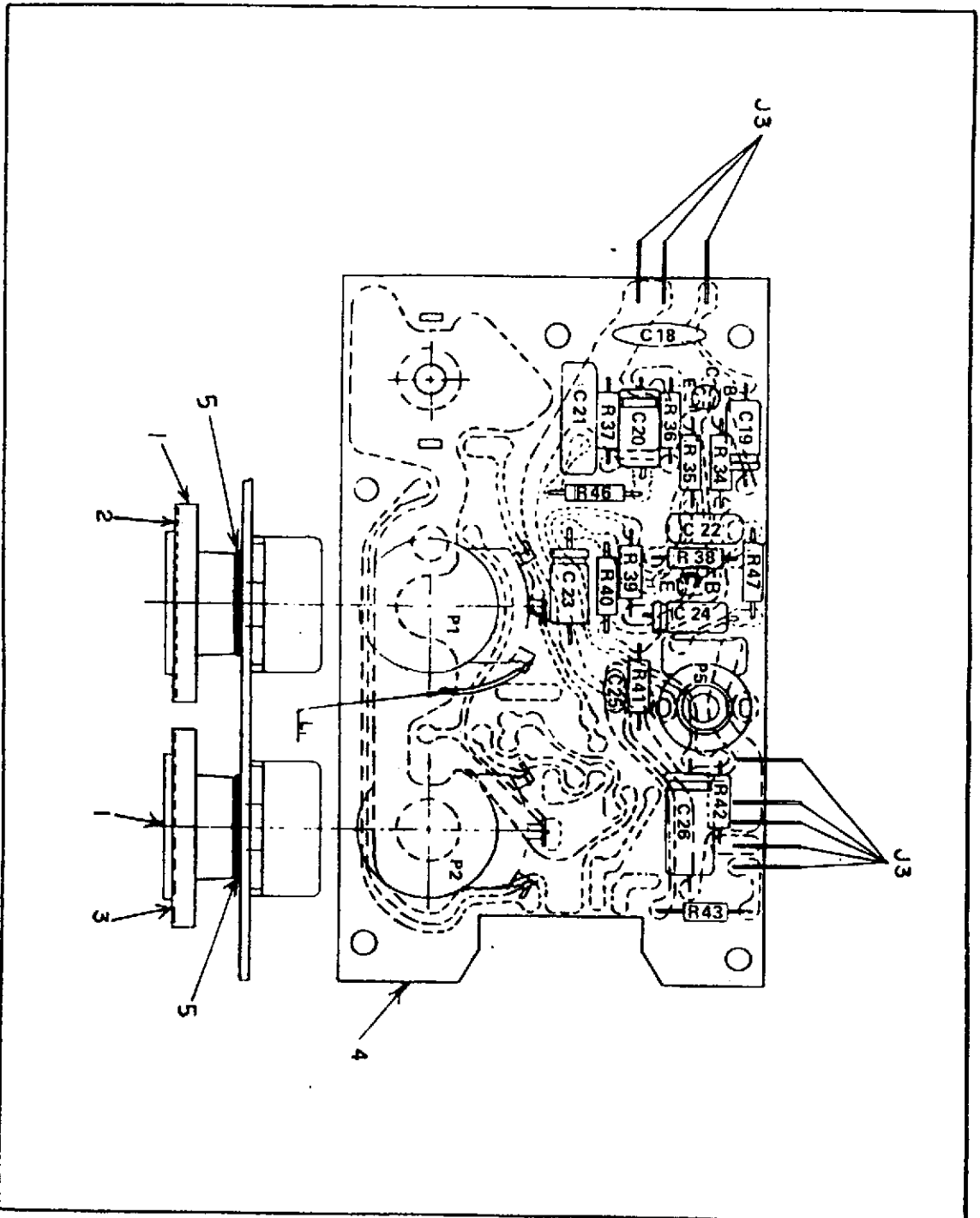

Figure 24 Tone/Volume Control Board Assembly Des. 1693

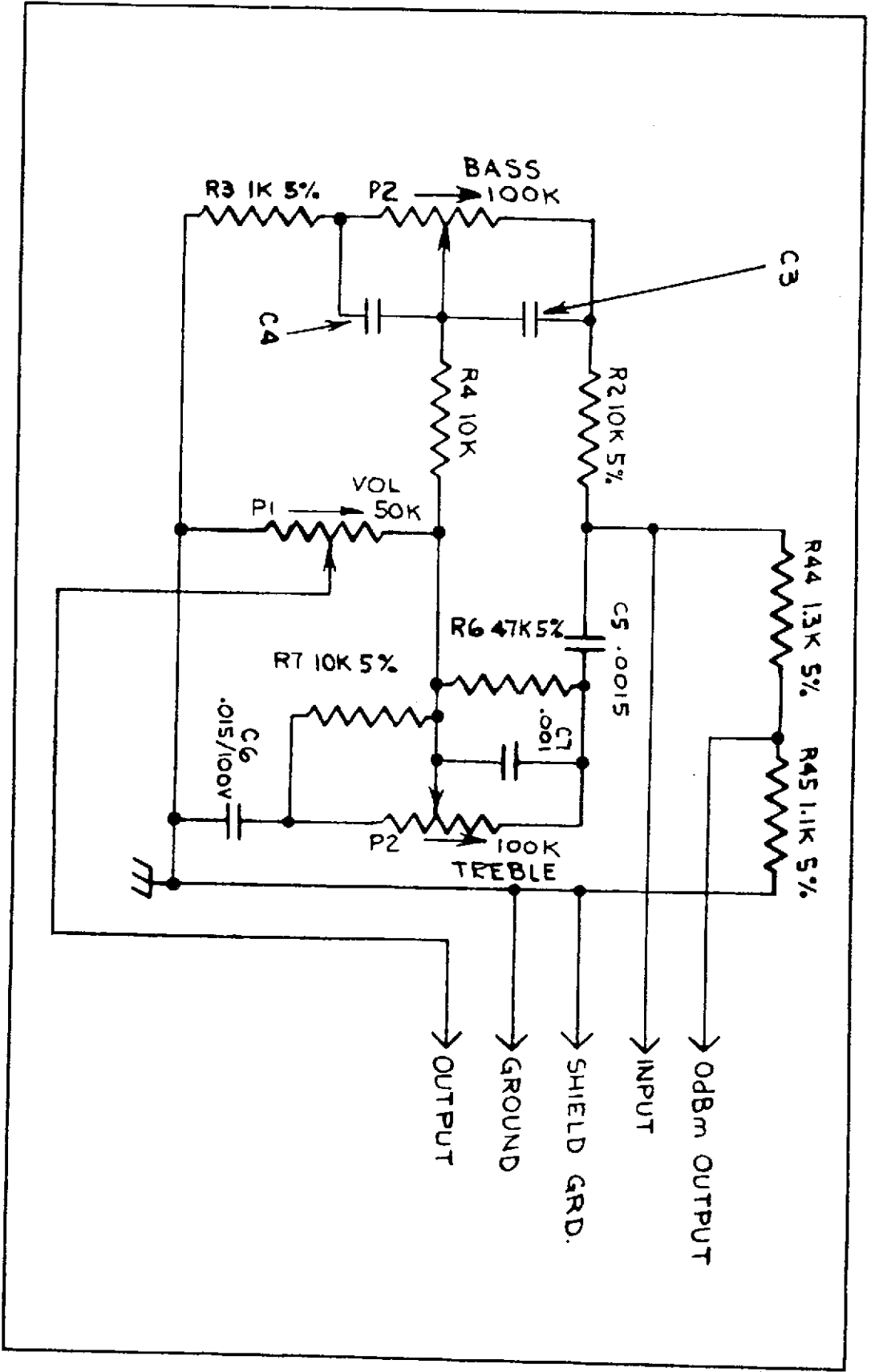

Figure 25. Circuit Diagram of Tone/Volume Control Board Des. 1695

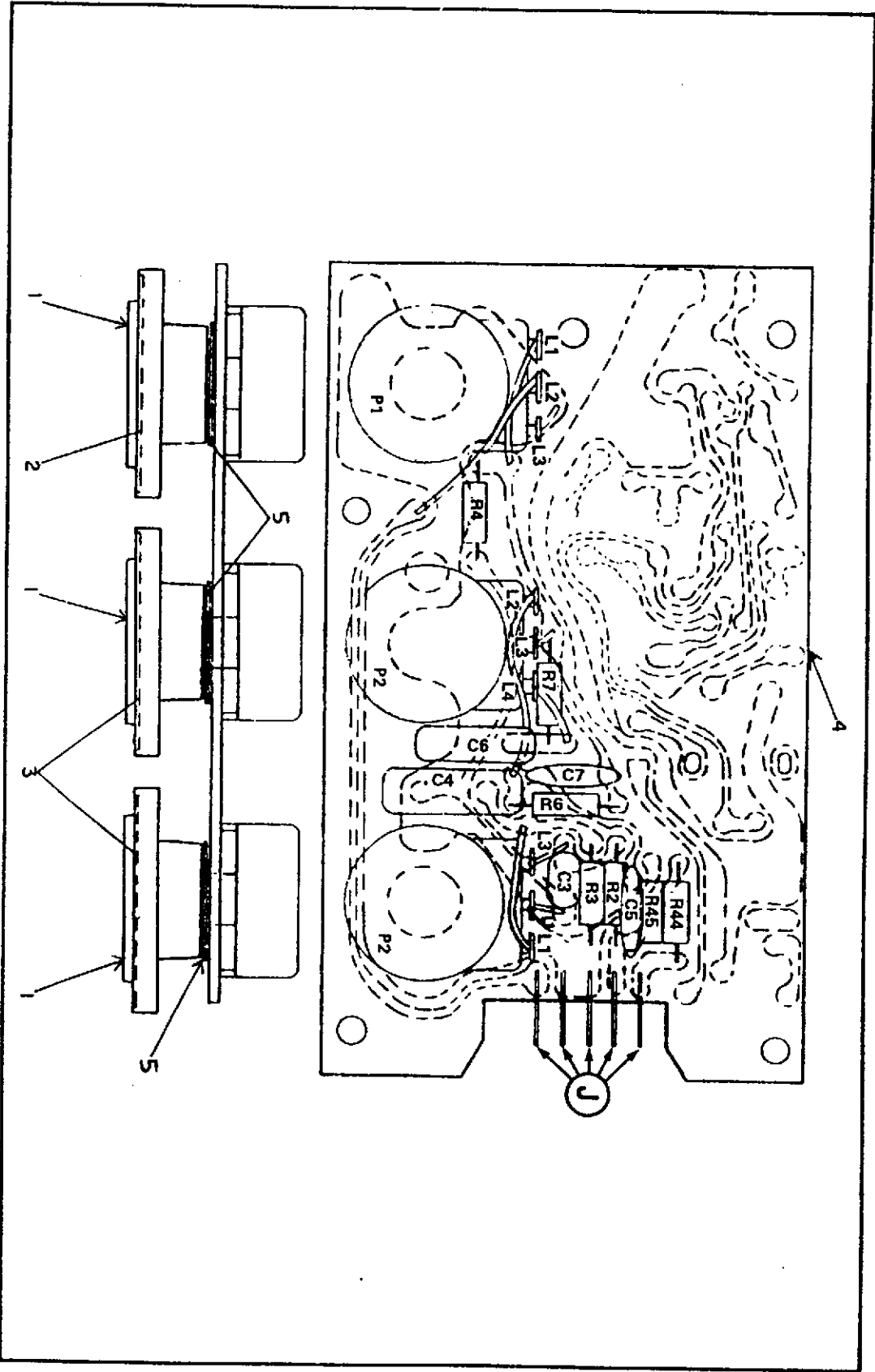
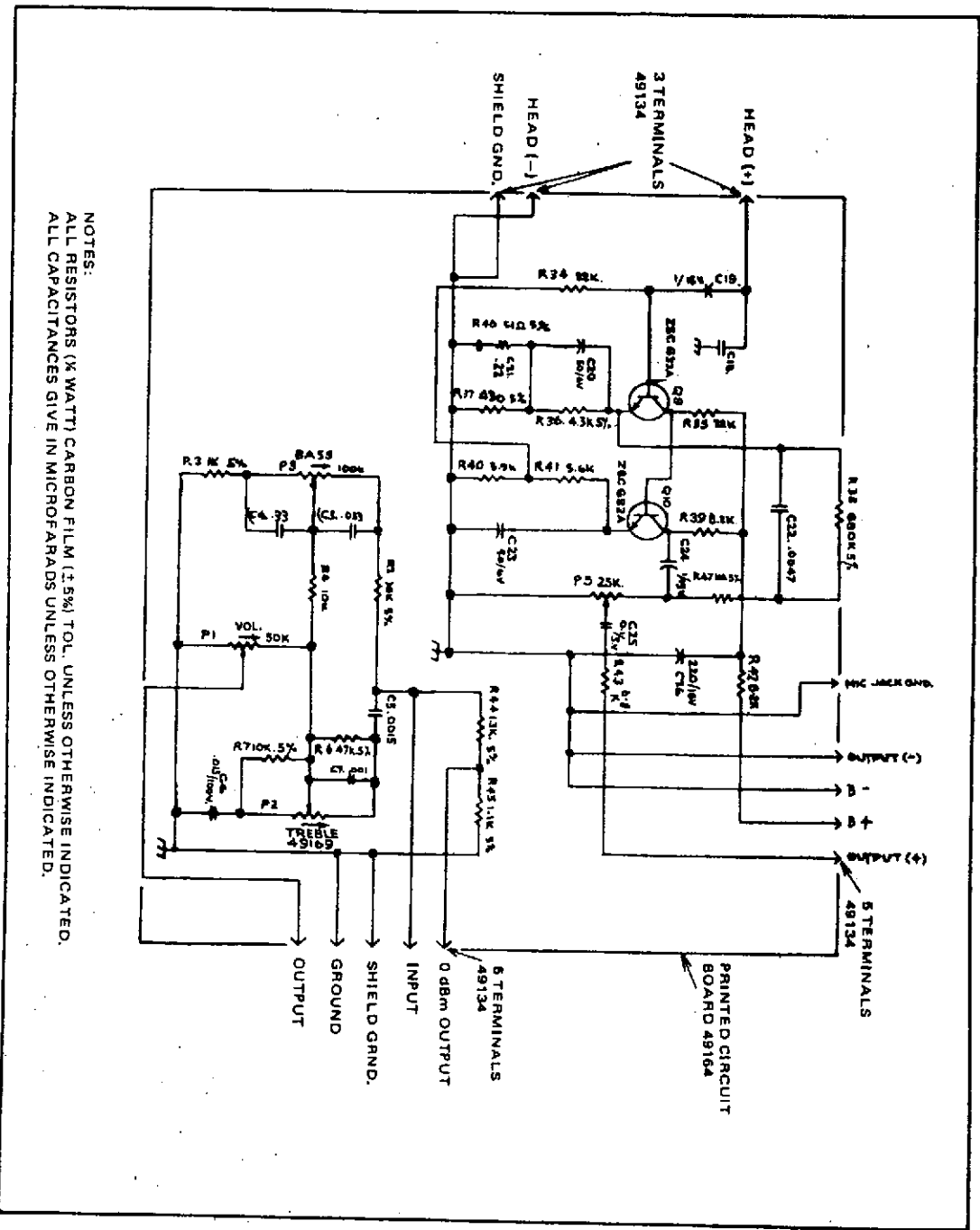

Figure 26.

Tone / Volume Control Board

Des.1695



NOTES:
 ALL RESISTORS (% WATT) CARBON FILM (±5%) TOL. UNLESS OTHERWISE INDICATED.
 ALL CAPACITANCES GIVE IN MICROFARADS UNLESS OTHERWISE INDICATED.

Figure 27. Circuit Diagram of Tone/Volume Control Board
 Des. 1694 & 1698

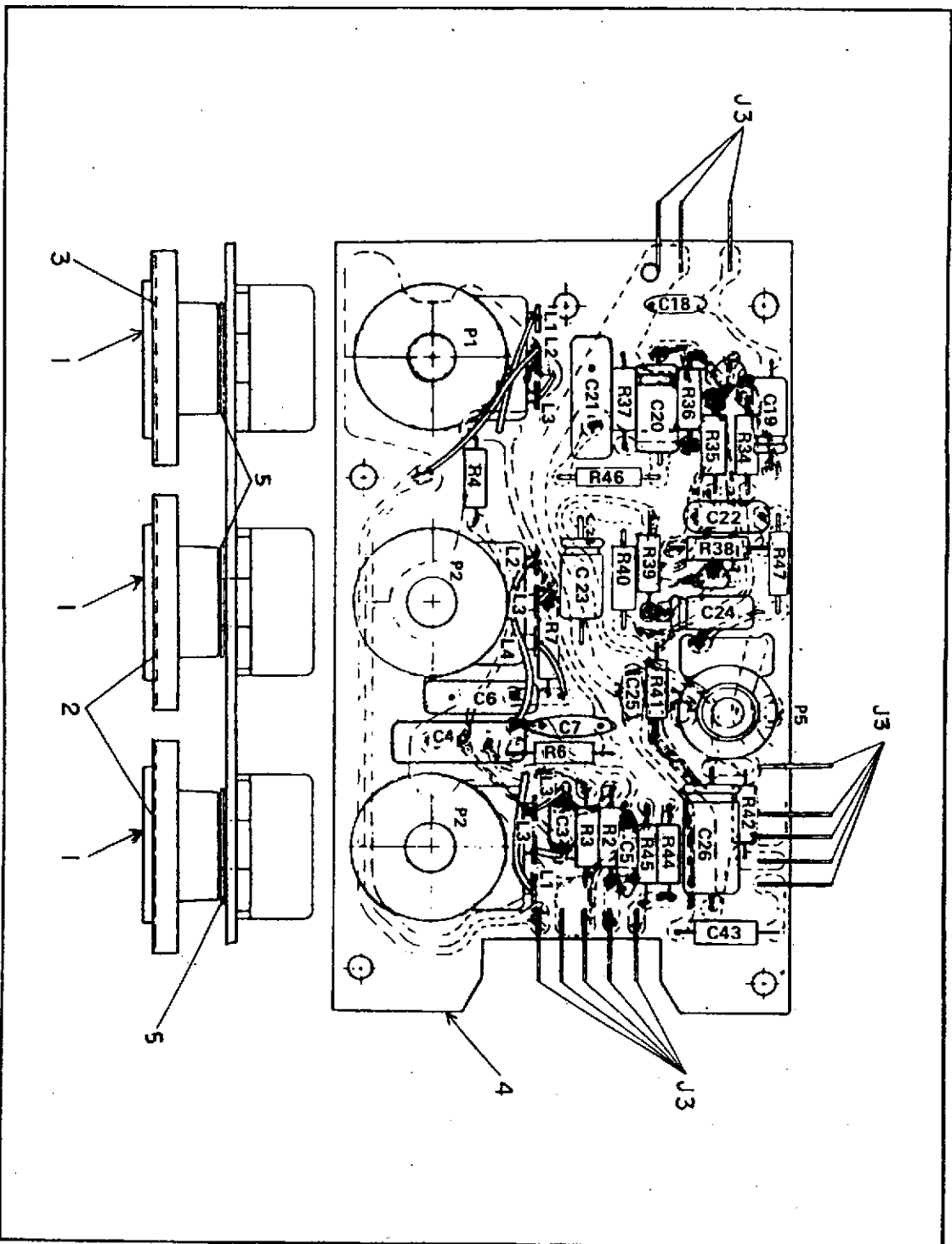
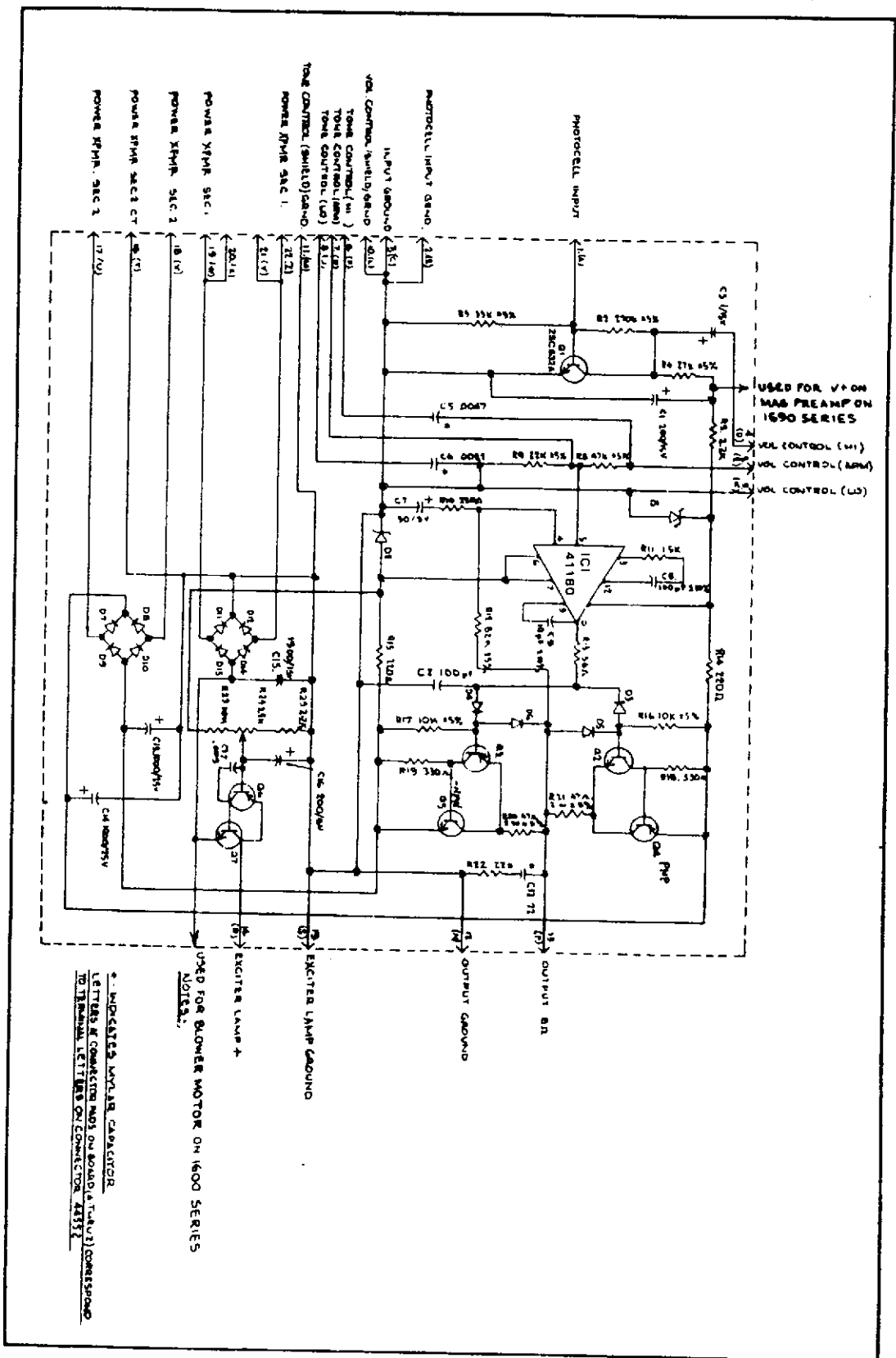

Figure 28. Tone / Volume Control Board Assembly Des. 1694 & 1698

Figure 29. Circuit Diagram of Main Amplifier P. C. B. Des. 1692 / 1693



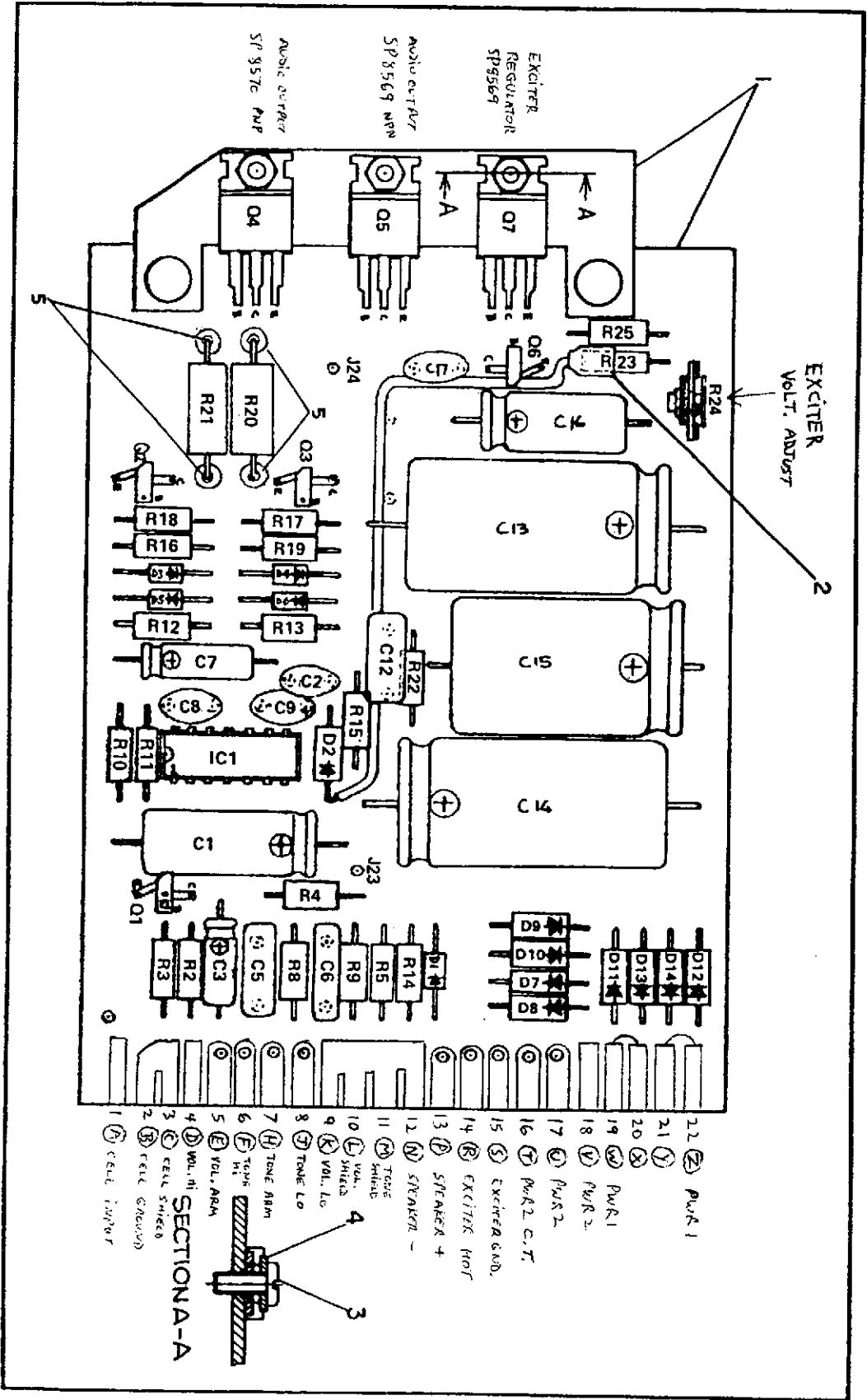
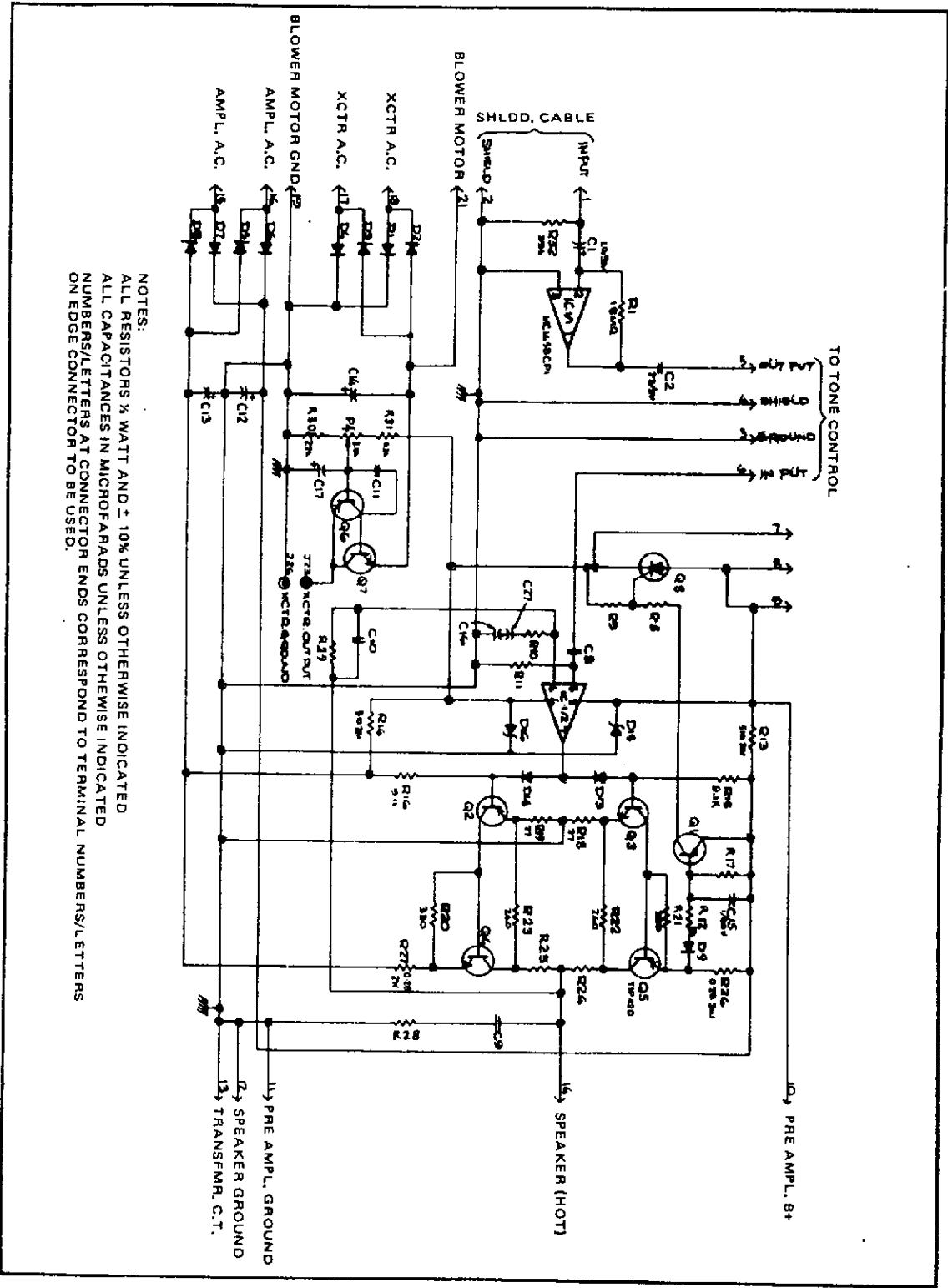

Figure 30. Main Amplifier P. C. B. Assembly

Des. 1692 / 1693



NOTES:
 ALL RESISTORS % WATT AND ± 10% UNLESS OTHERWISE INDICATED
 ALL CAPACITANCES IN MICROFARADS UNLESS OTHERWISE INDICATED
 NUMBERS/LETTERS AT CONNECTOR ENDS CORRESPOND TO TERMINAL NUMBERS/LETTERS
 ON EDGE CONNECTOR TO BE USED.

Figure 31. Circuit Diagram of Main Amplifier P.C.B. Des.1694, 1695 & 1698

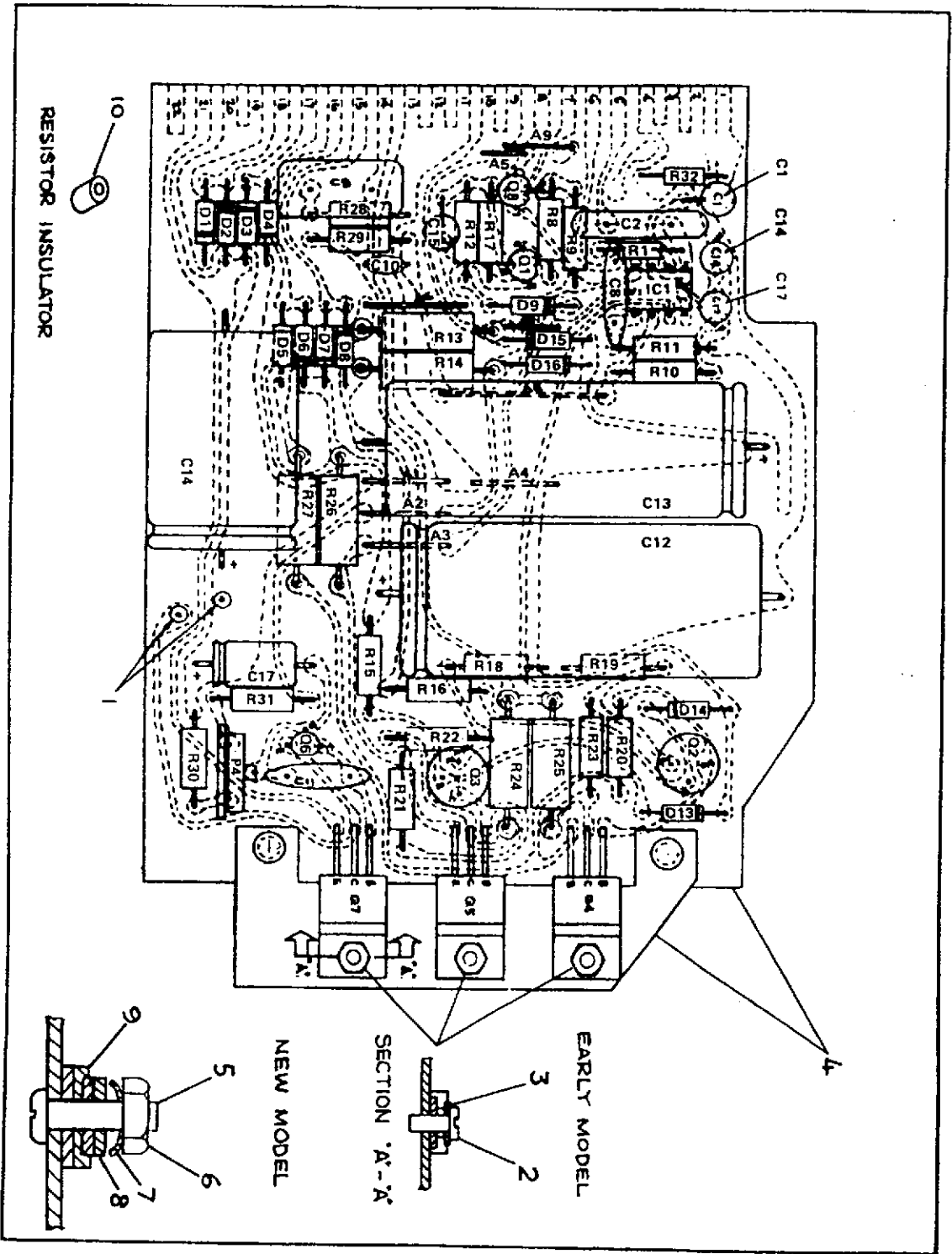

Figure 32. Main Amplifier P.C.B. Assembly Des. 1694, 1695 & 1698

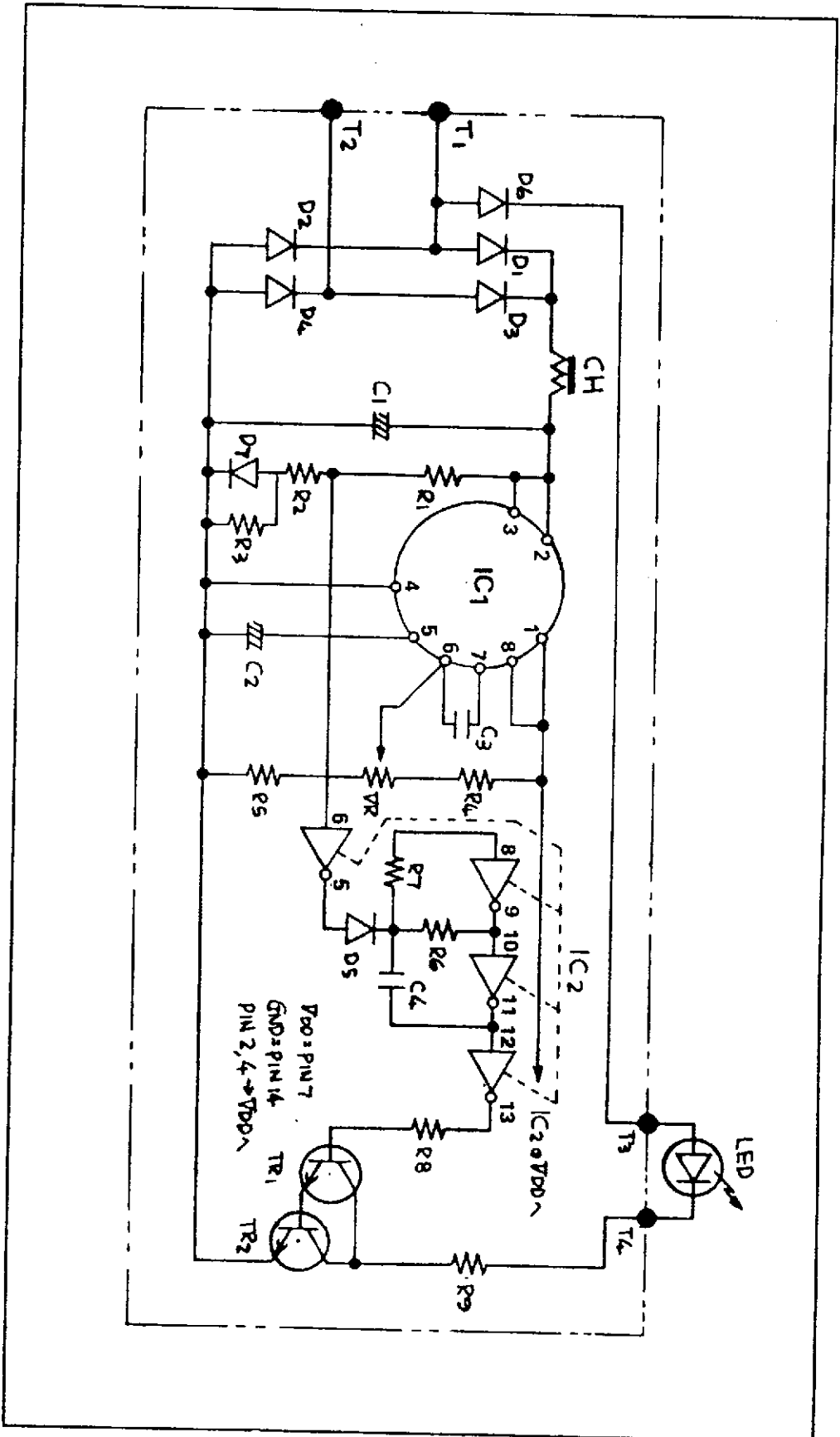

Figure 33. Circuit Diagram of Lamp Warning P.C.B. Assembly

DES. 1694, 1695 and 1698

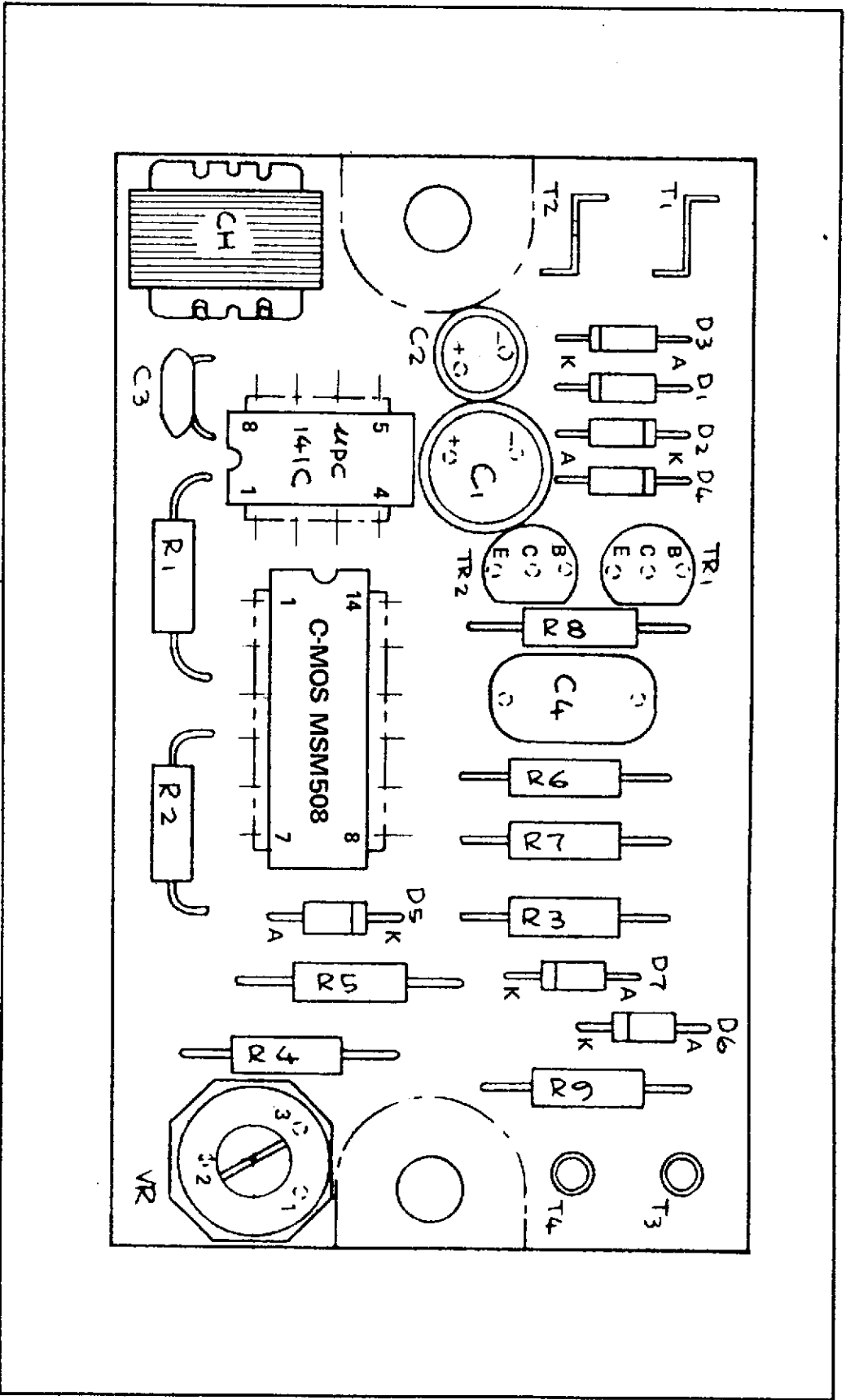

Figure 34. Lamp Warning P.C.B. Assembly

DES. 1694, 1695 and 1698

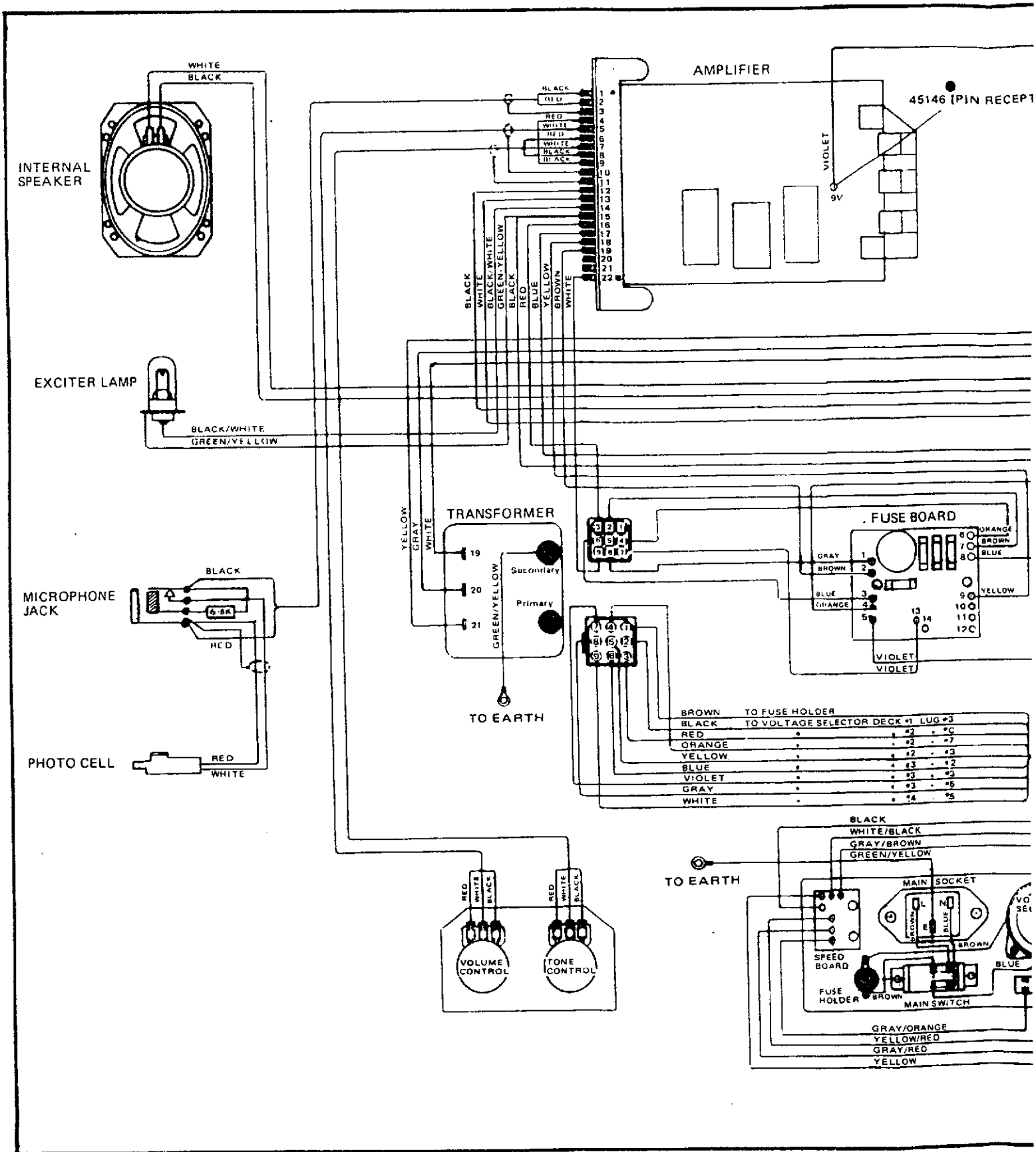

Figure 35. Pictorial Wiring Diagram

Figure 35.

DES 1692
NEW PICTORIAL WIRING
DIAGRAM
FROM SERIAL NUMBER
6223007

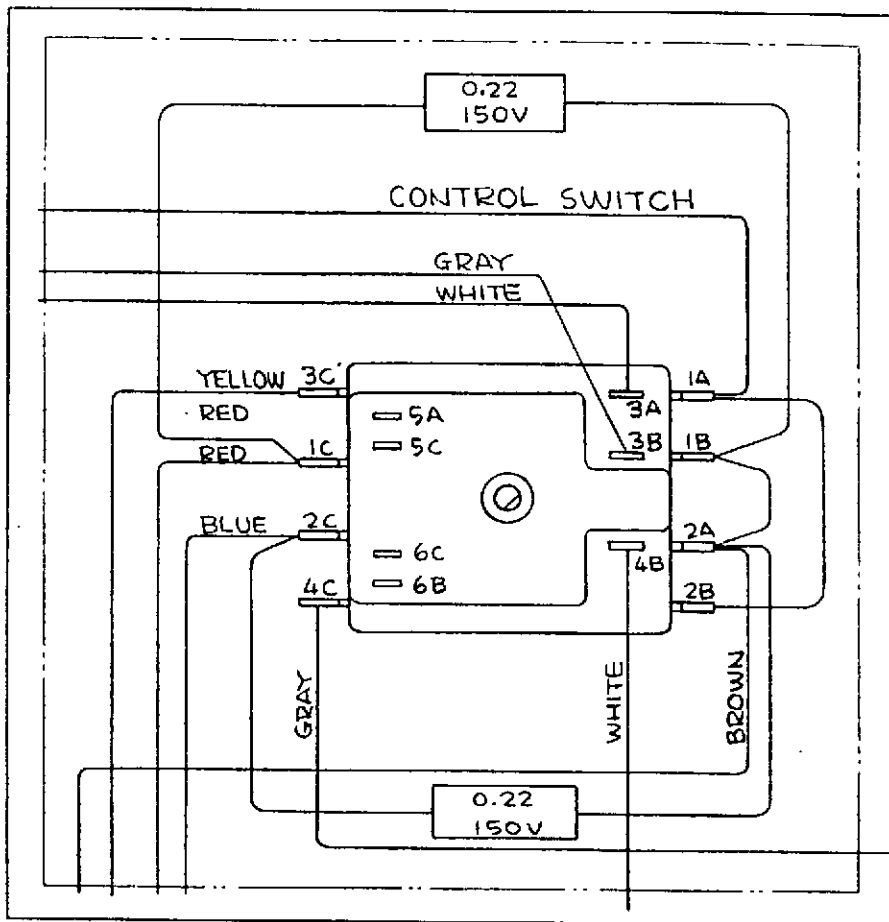
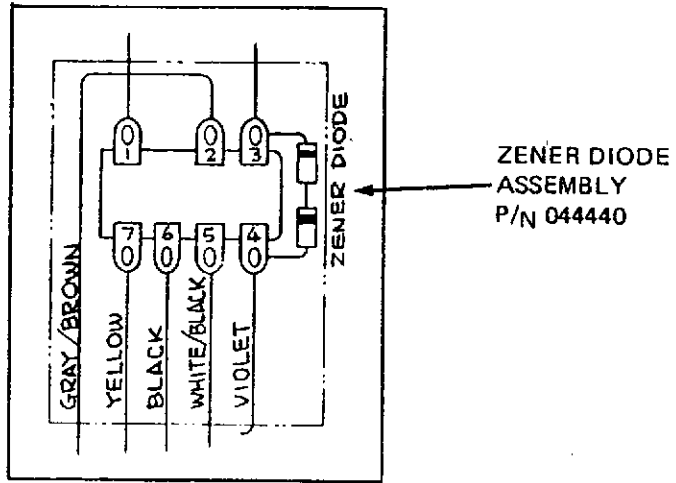
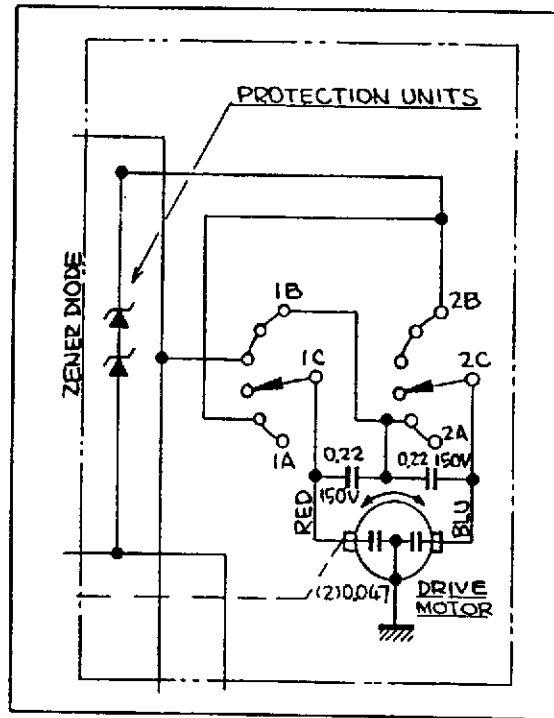

Figure 36.
DES 1692
NEW SCHEMATIC
FROM SERIAL NUMBER
6223007



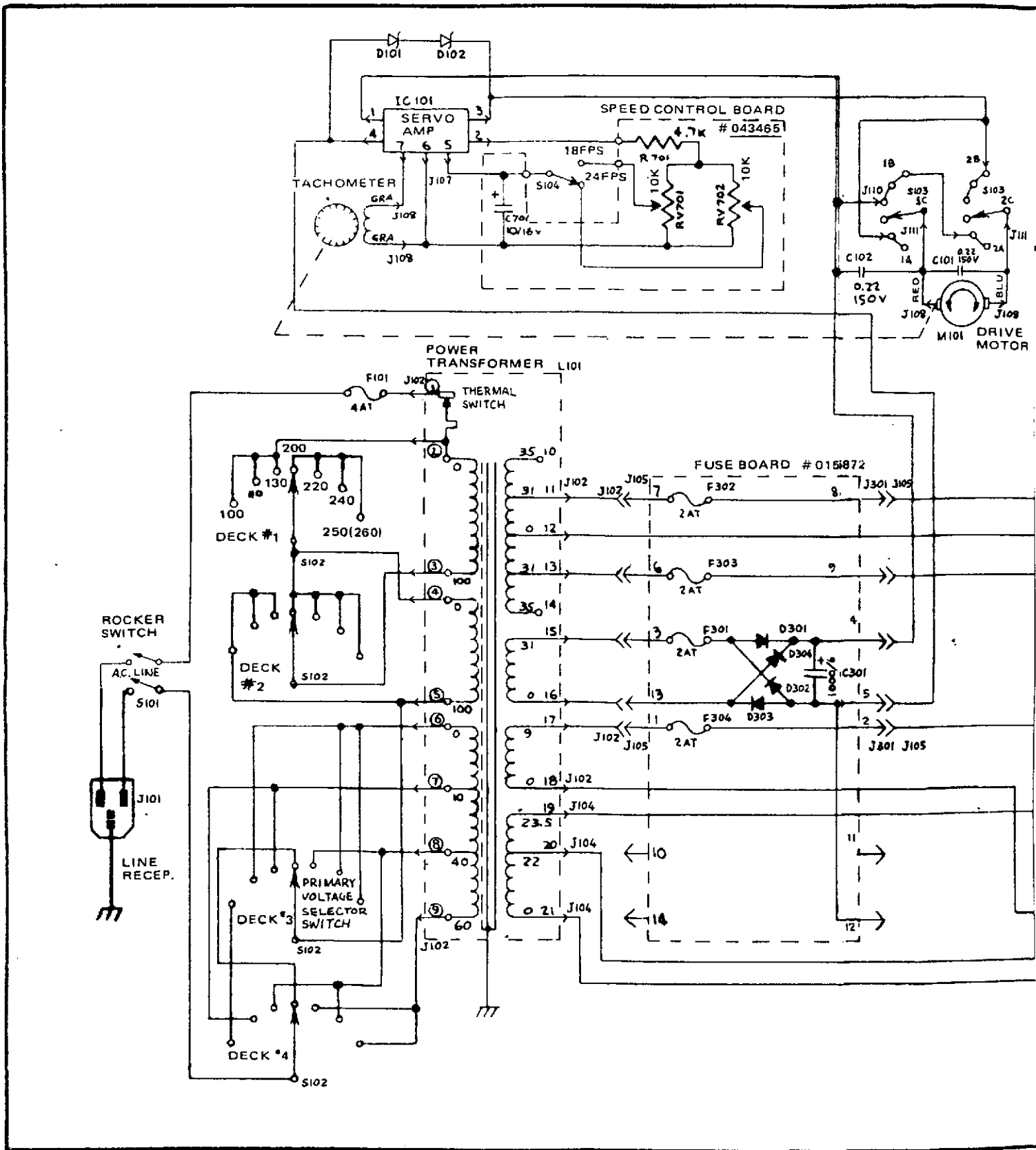
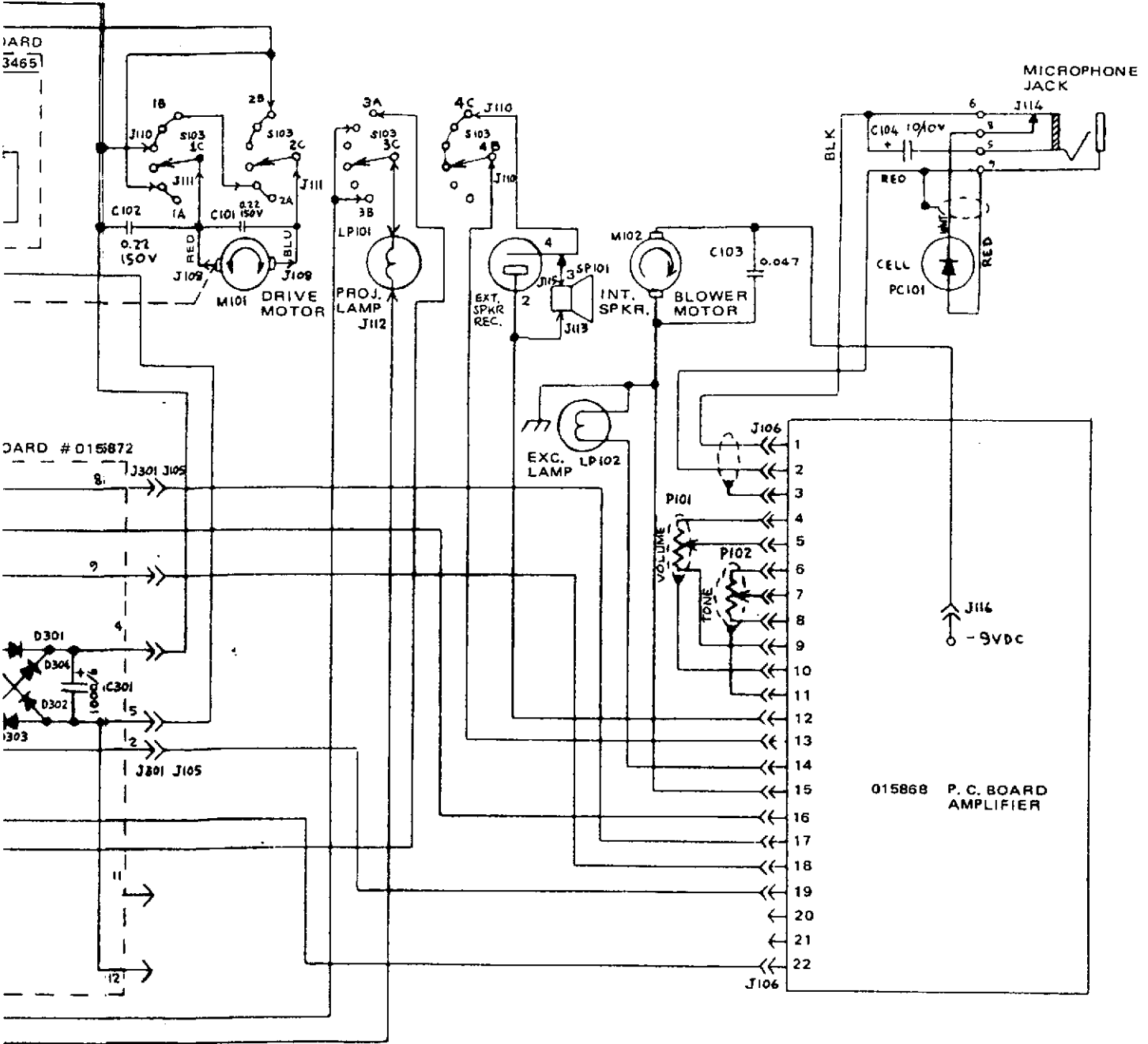

Figure 36. Projector Schematic



Schematic Diagram

Des. 1692

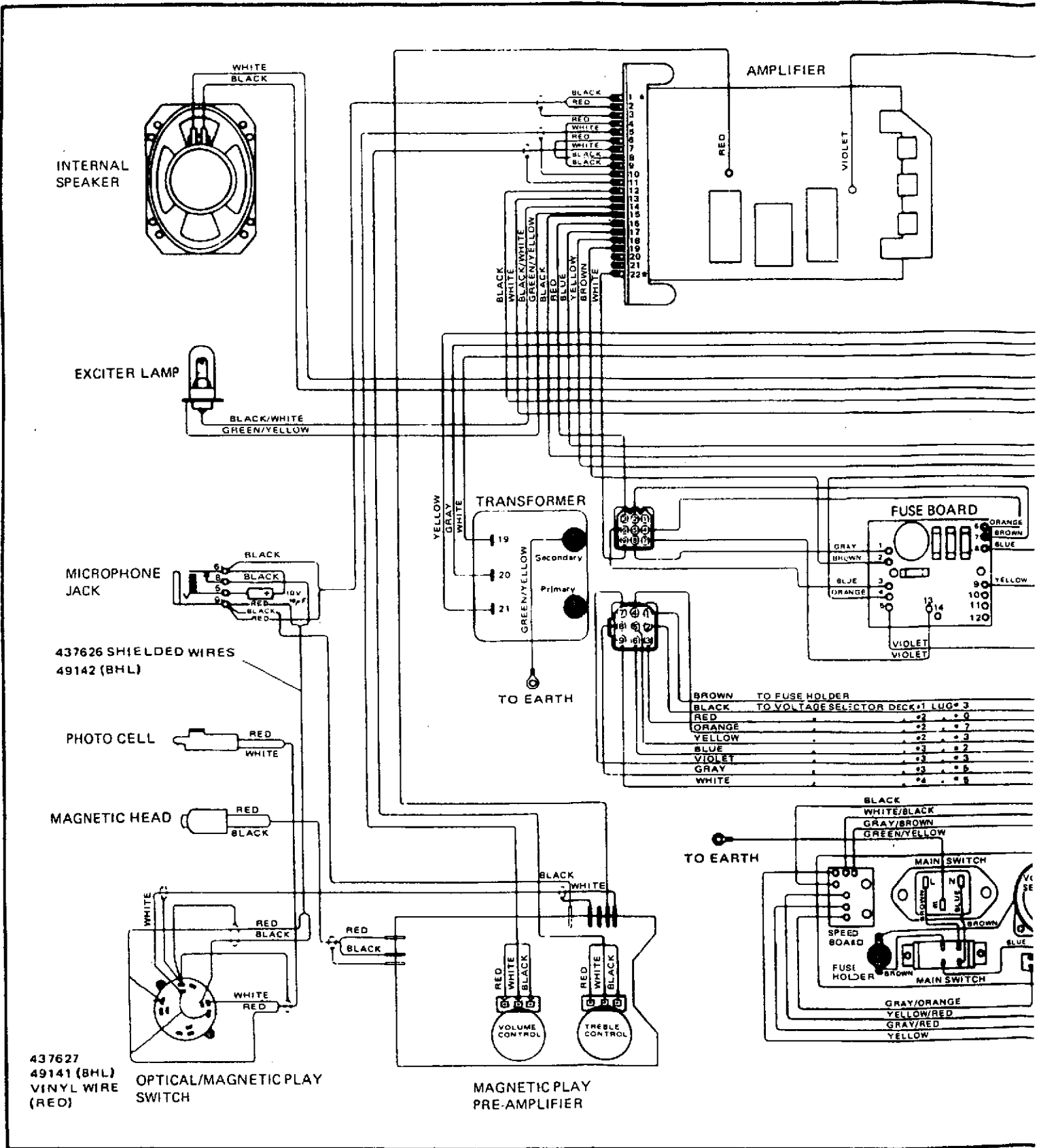
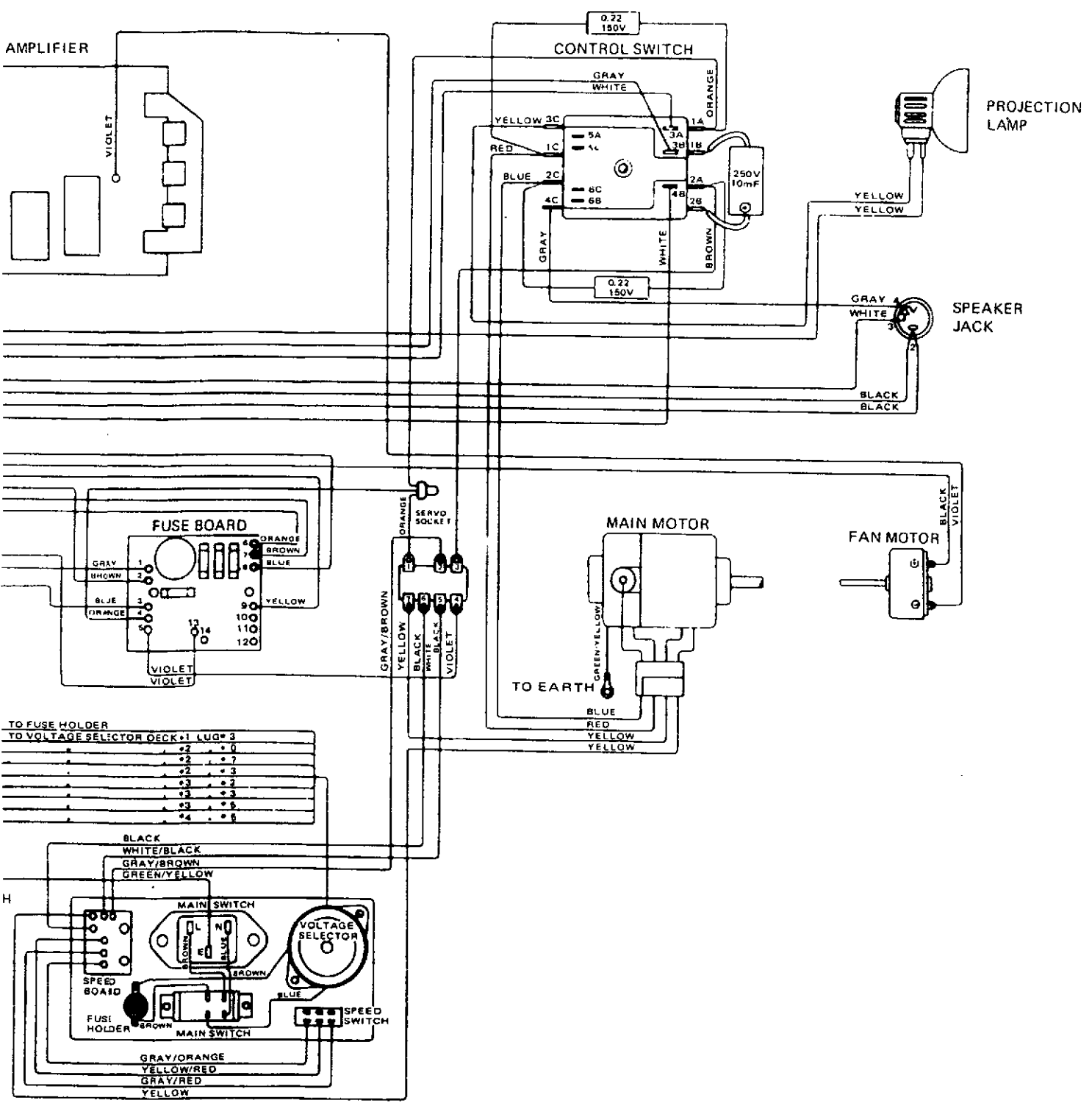

Figure 37. Pictorial Wiring



rial Wiring Diagram Des. 1693

Figure 37.
 DES 1693
 NEW PICTORIAL WIRING
 DIAGRAM
 FROM SERIAL NUMBER
 6223007

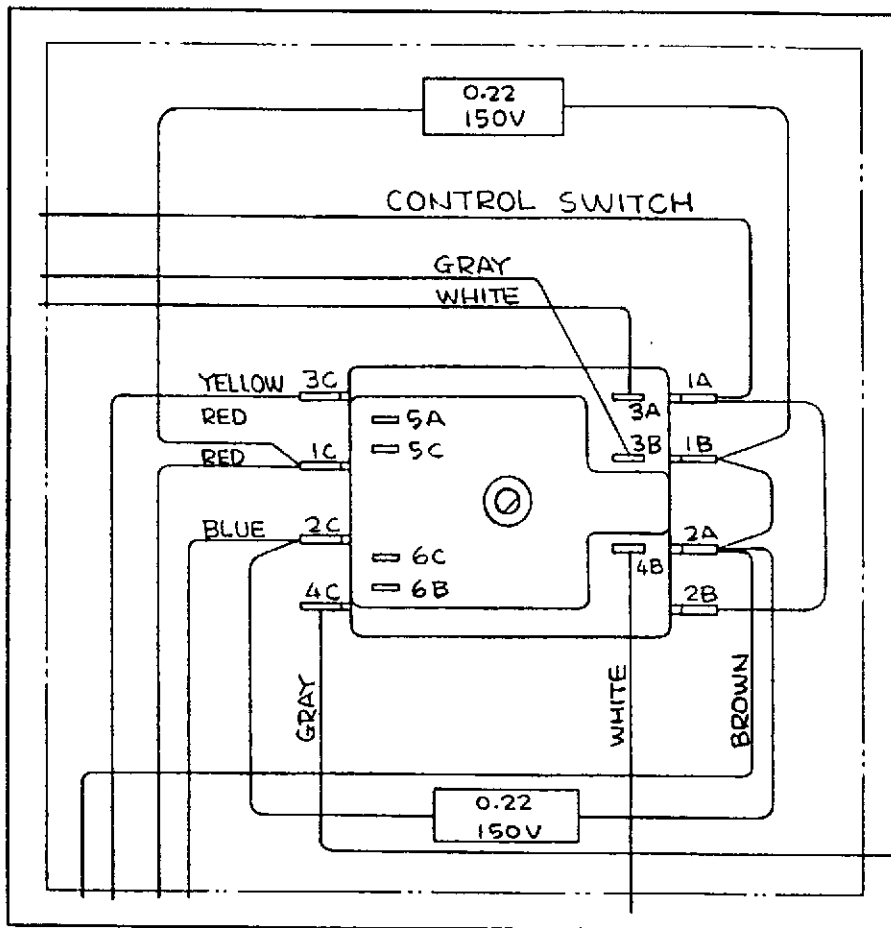
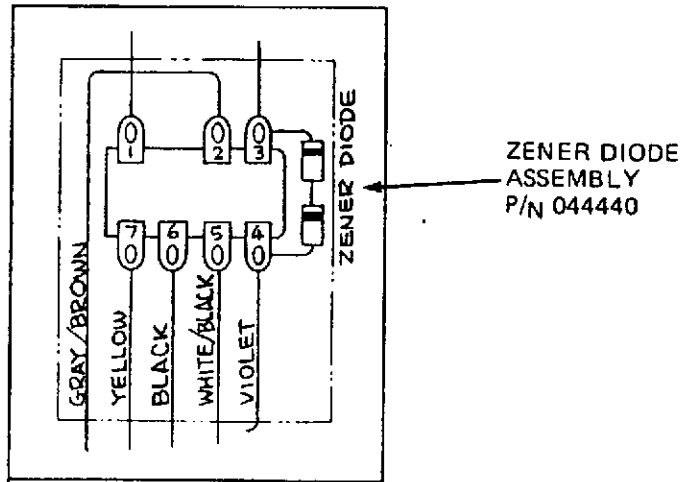
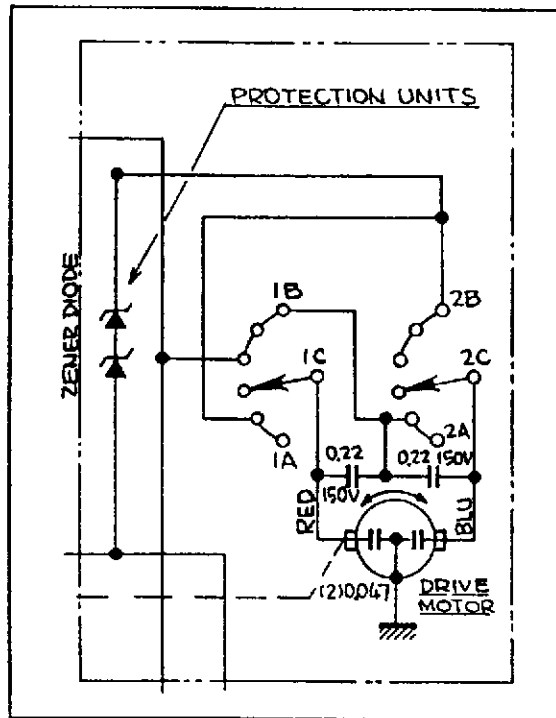

Figure 38.
DES 1693
NEW SCHEMATIC
FROM SERIAL NUMBER
6223007



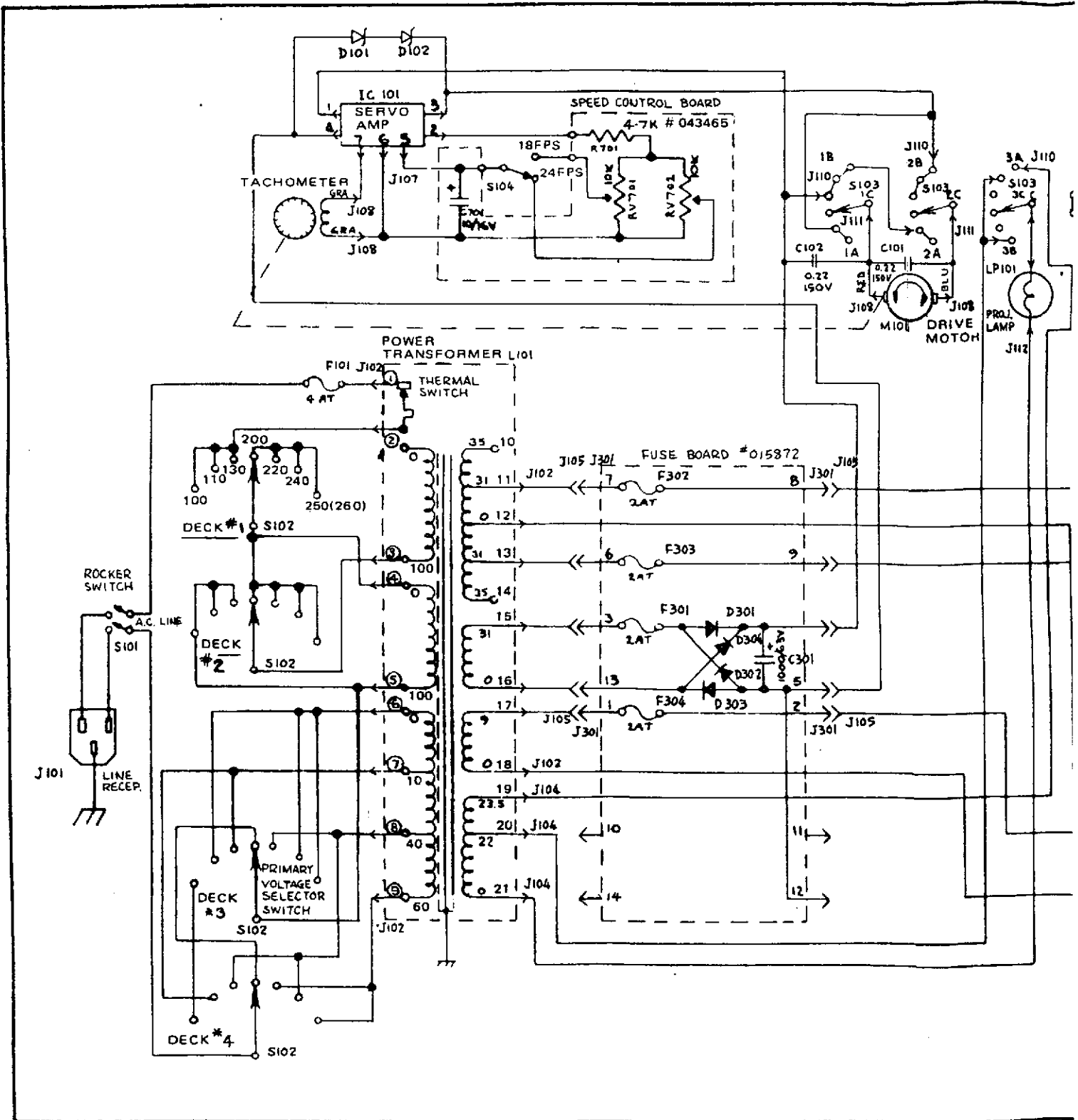
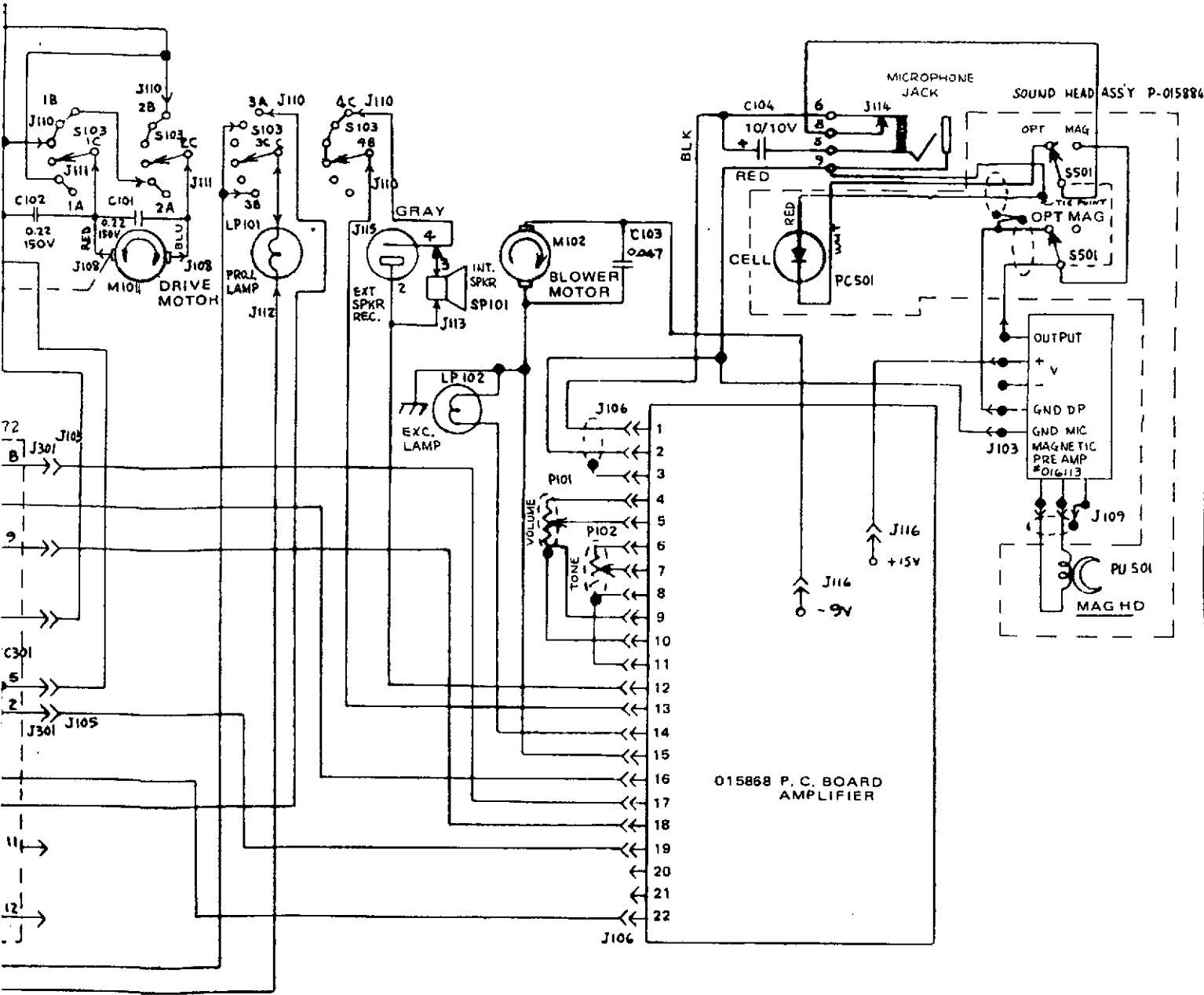

Figure 38. Projector Schematic



Schematic Diagram

Des. 1693

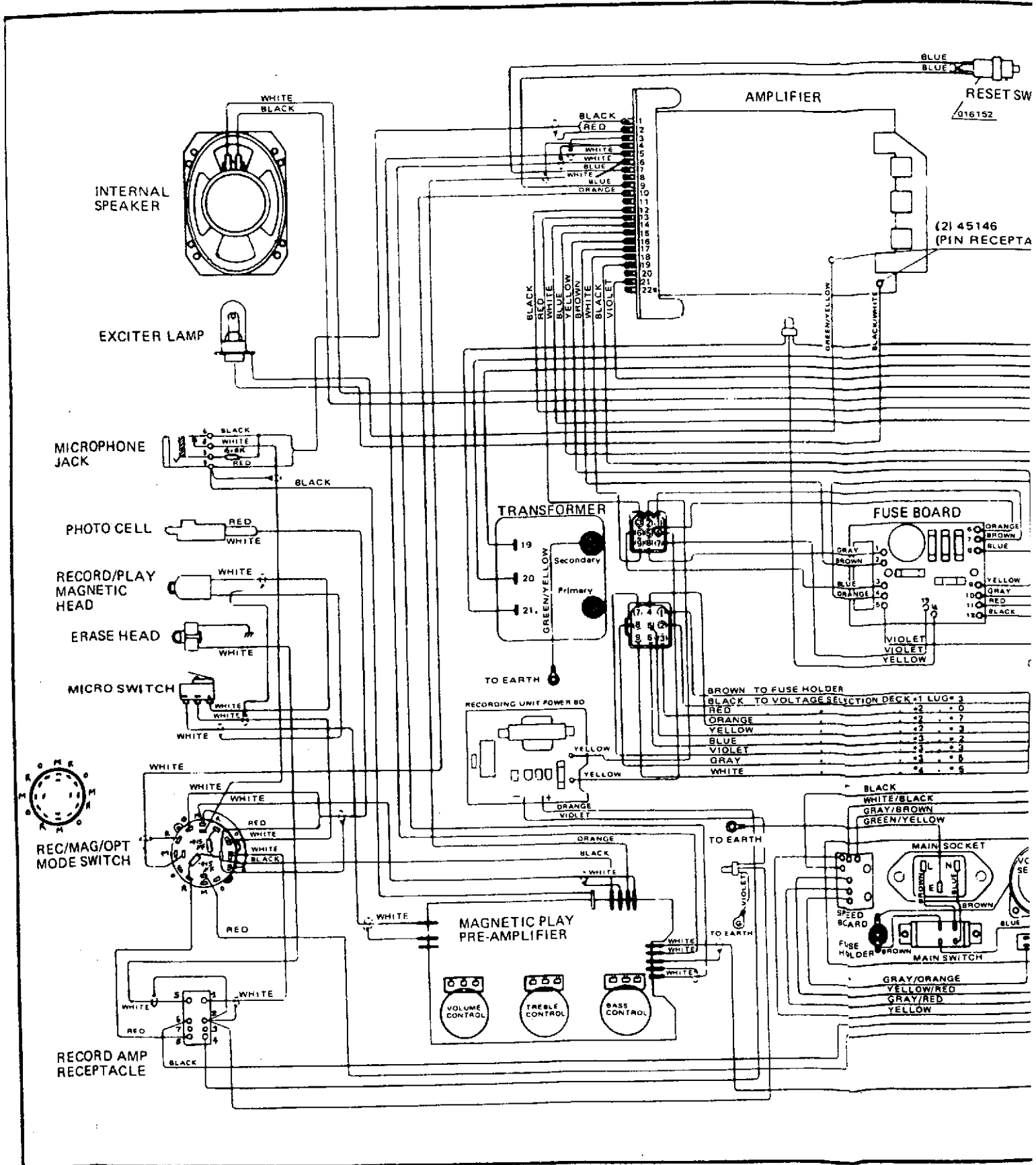
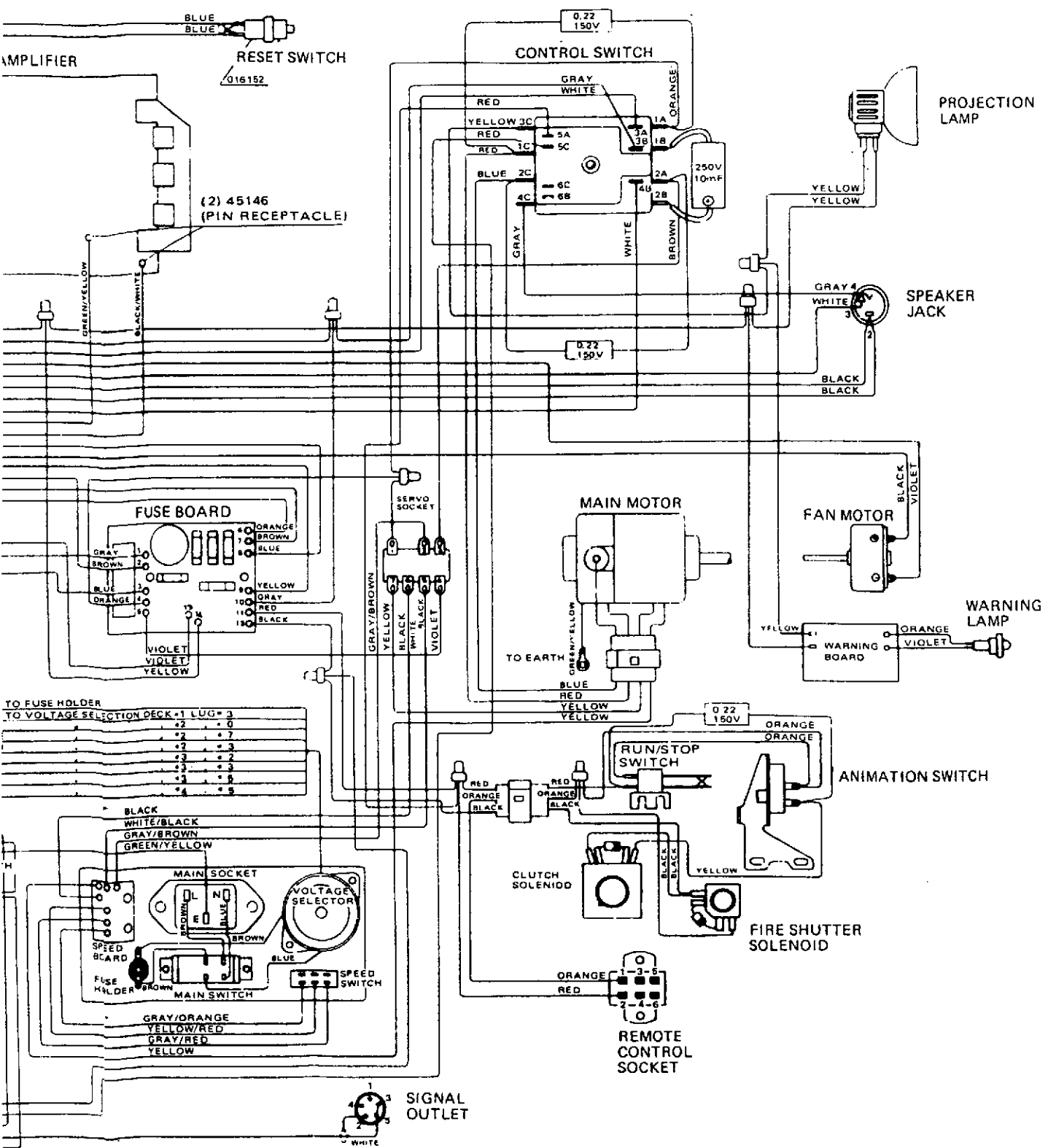

Figure 39. Pictorial Wiring Dia



Wiring Diagram Des. 1694

Figure 39.

DES 1694
NEW PICTORIAL WIRING
DIAGRAM
FROM SERIAL NUMBER
6223007

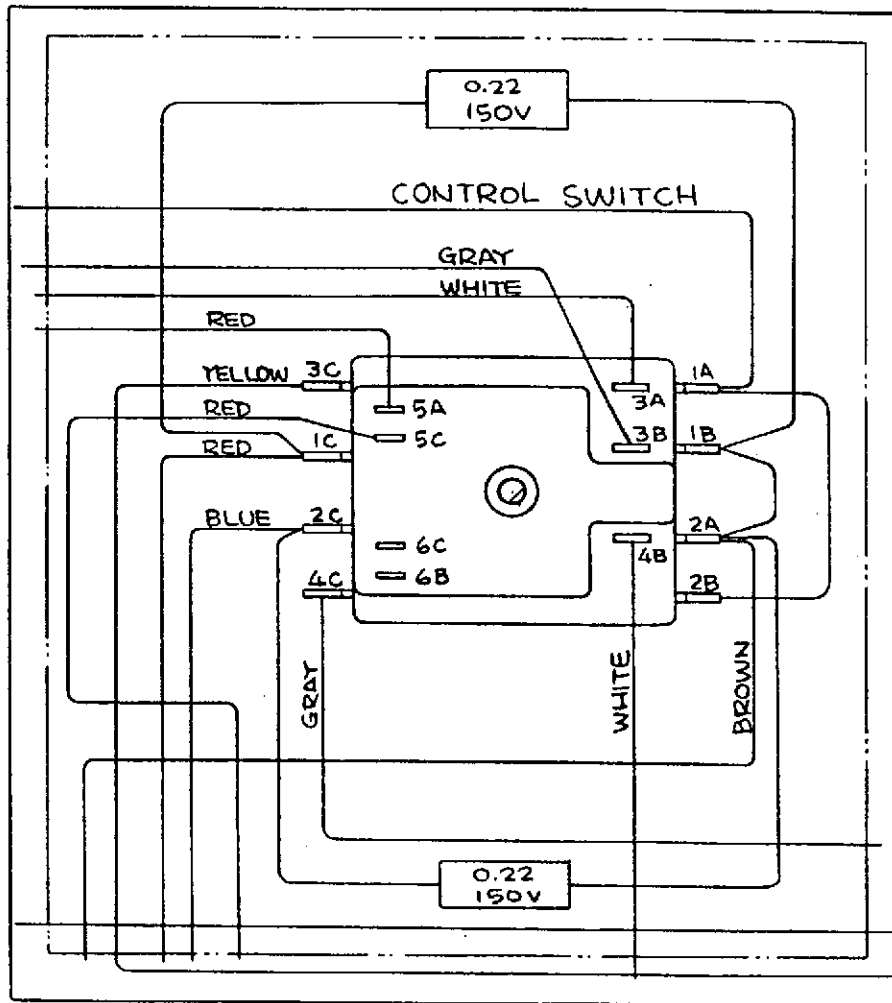
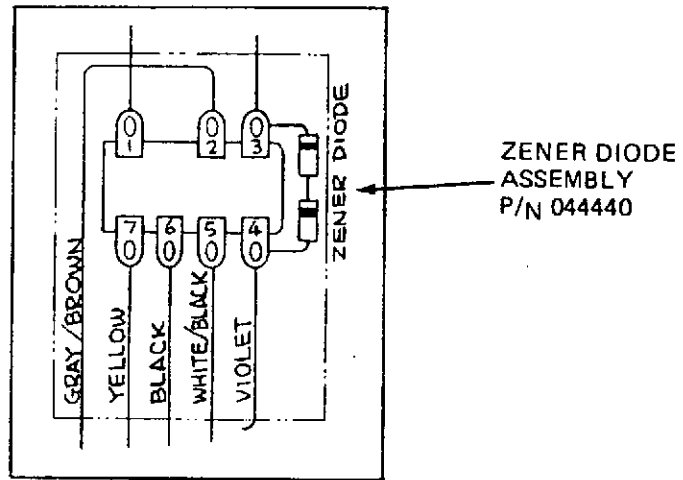
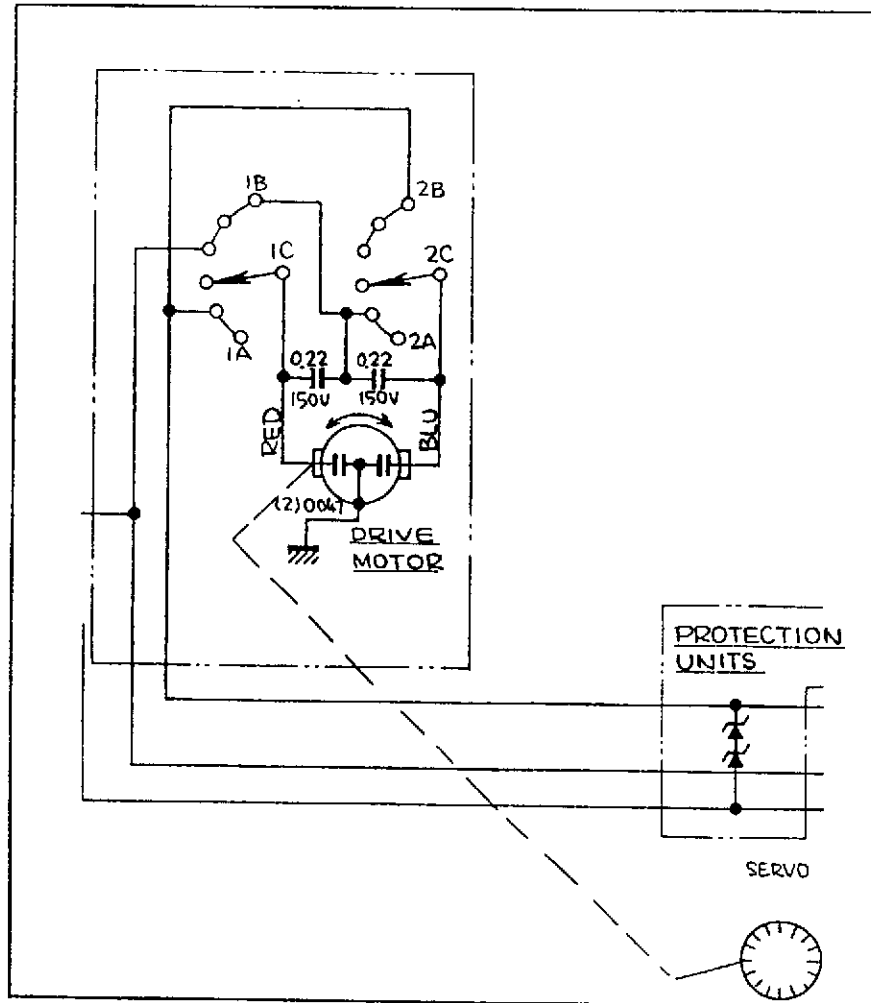

Figure 40.
DES 1694
NEW SCHEMATIC
FROM SERIAL NUMBER
6223007



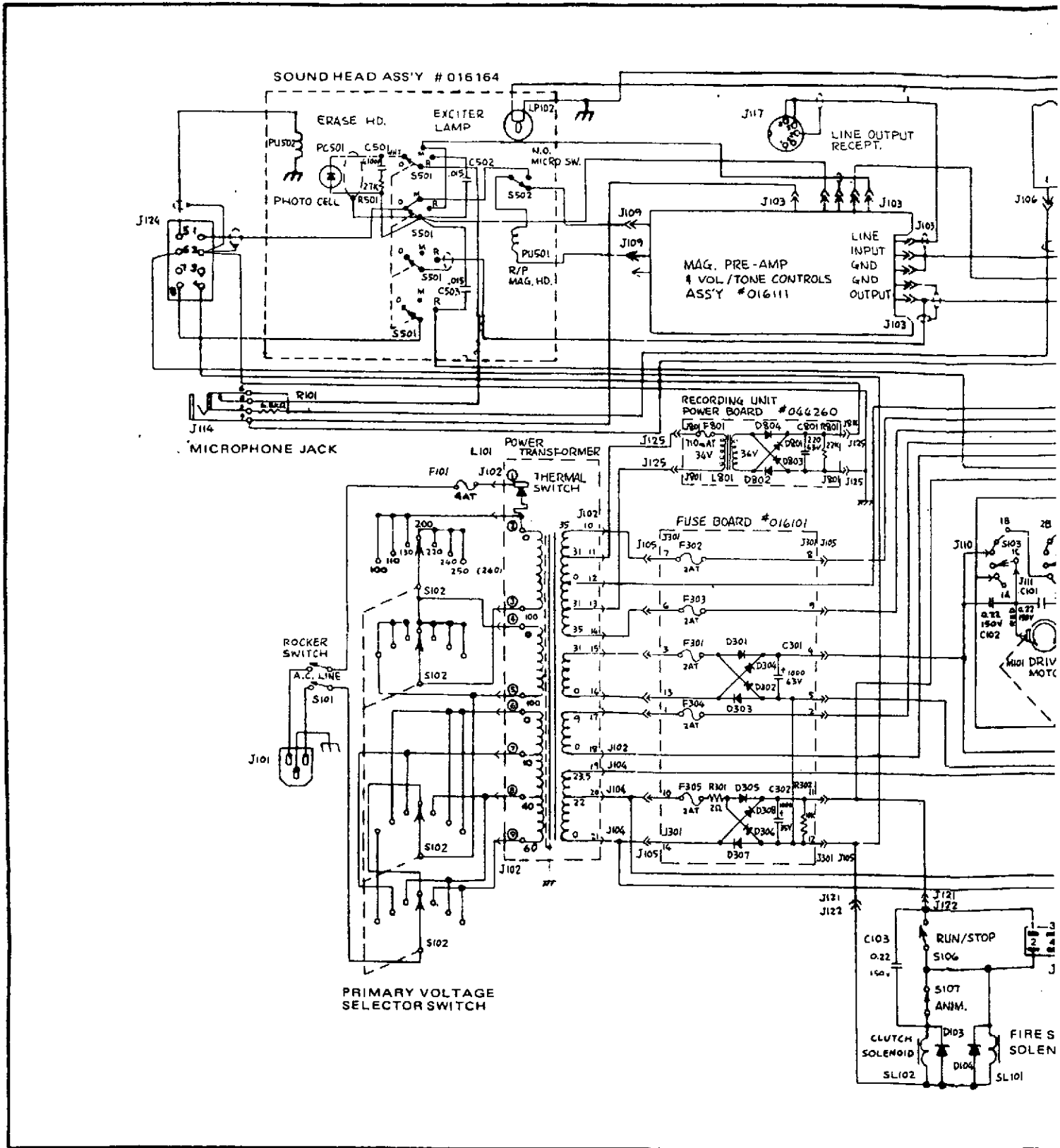
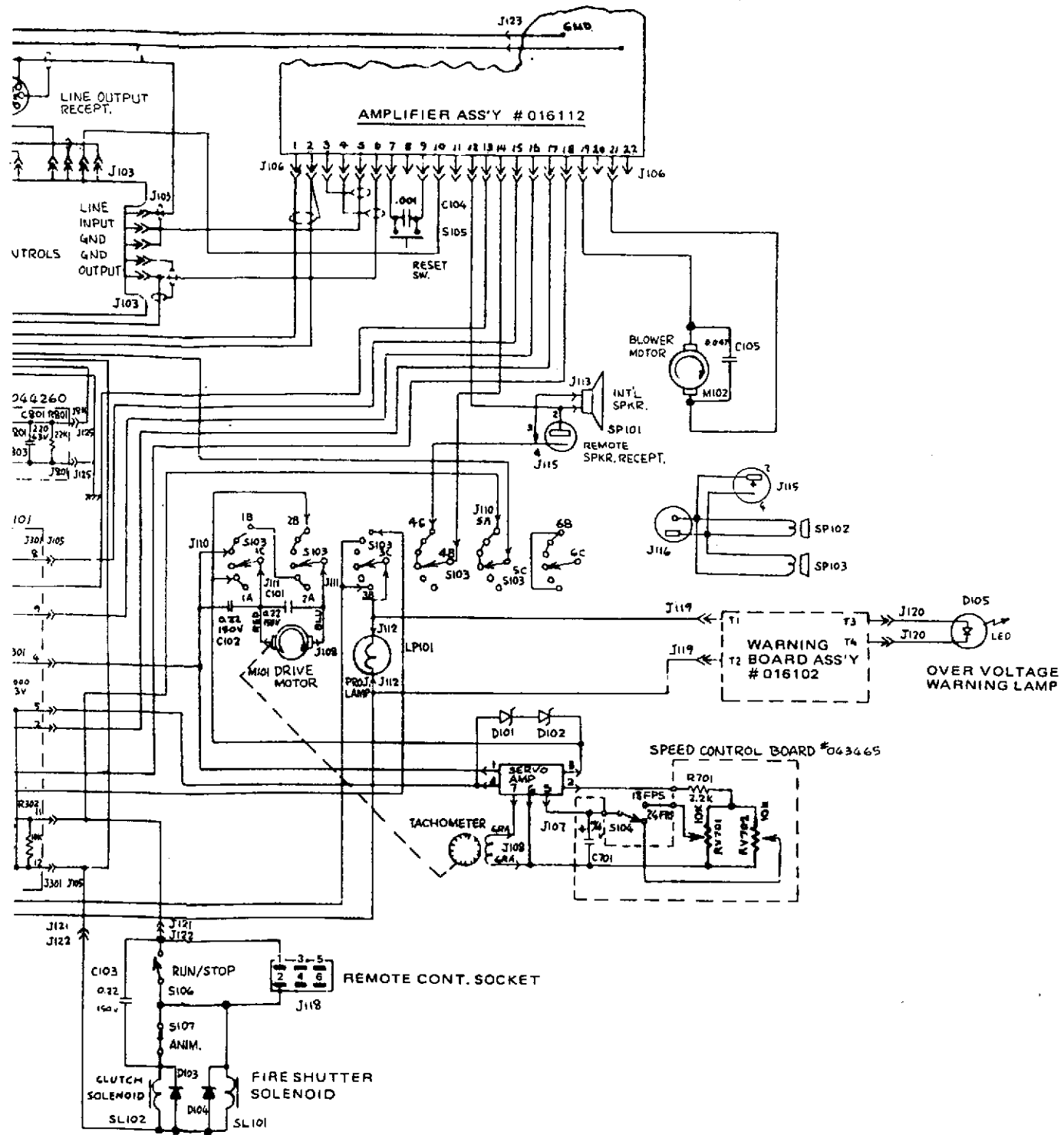

Figure 40. Projector Schematic Dic



Schematic Diagram

Des. 1694

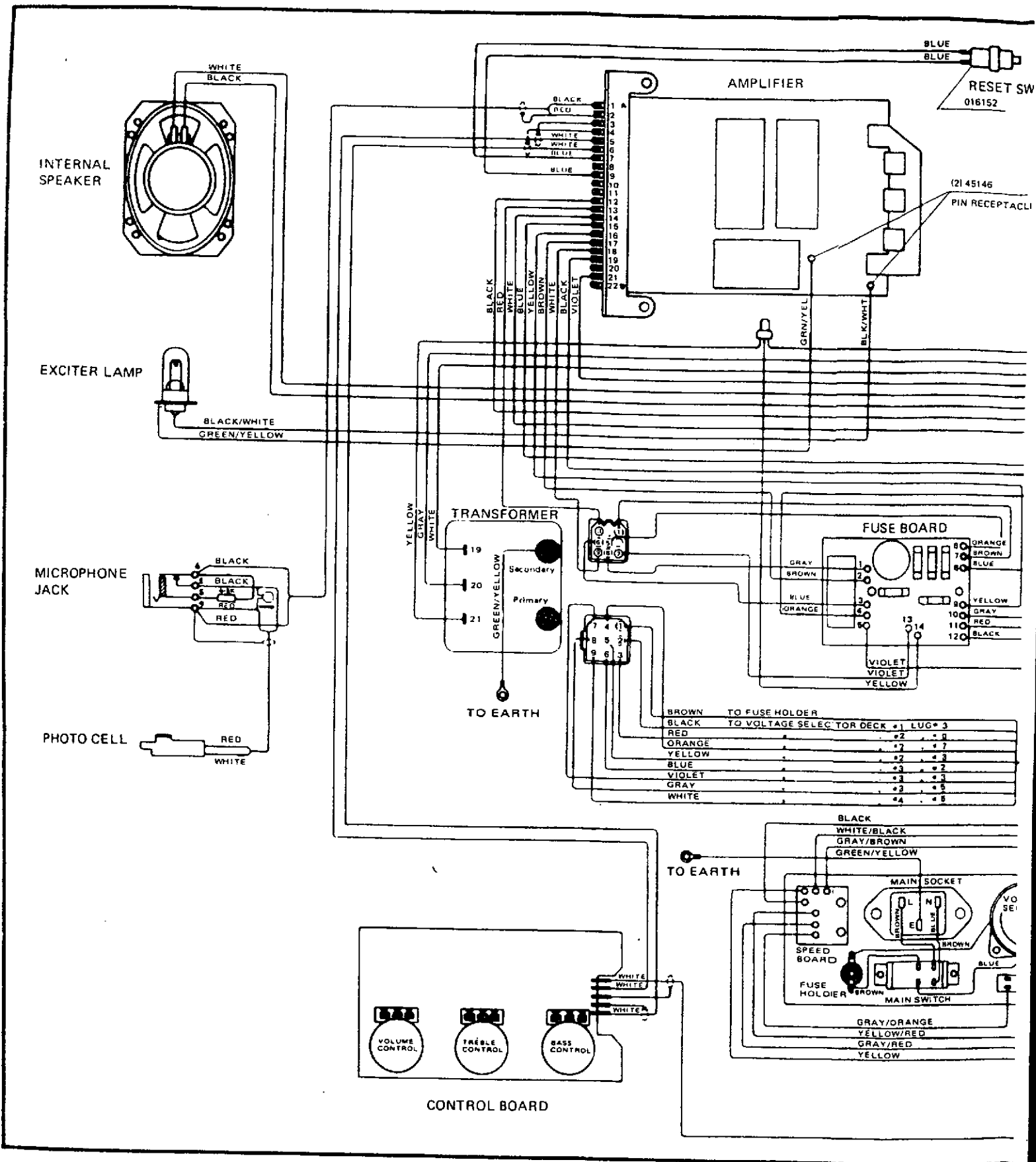
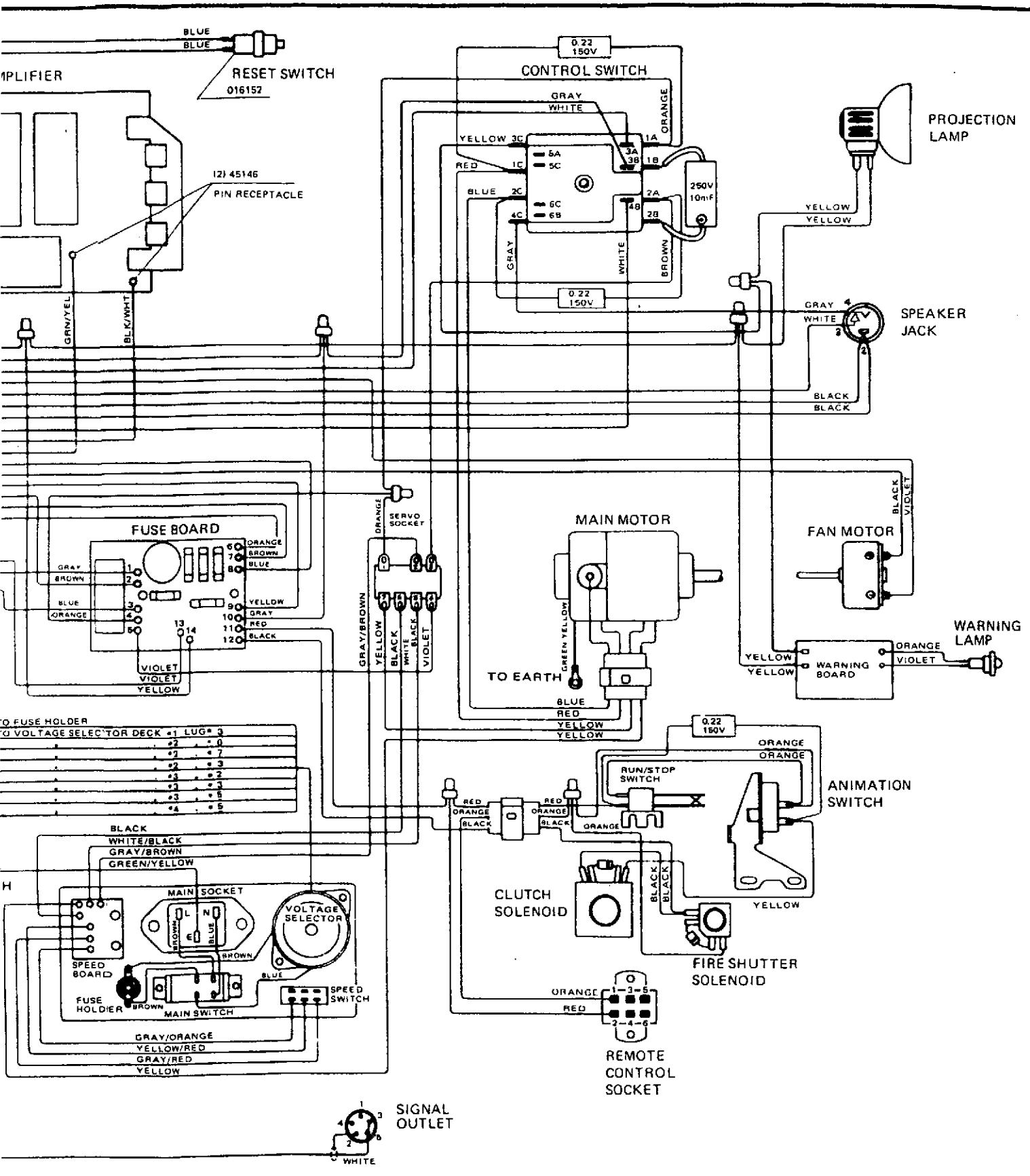

Figure 41. Pictorial Wiring Diagram



Wiring Diagram

Des. 1695

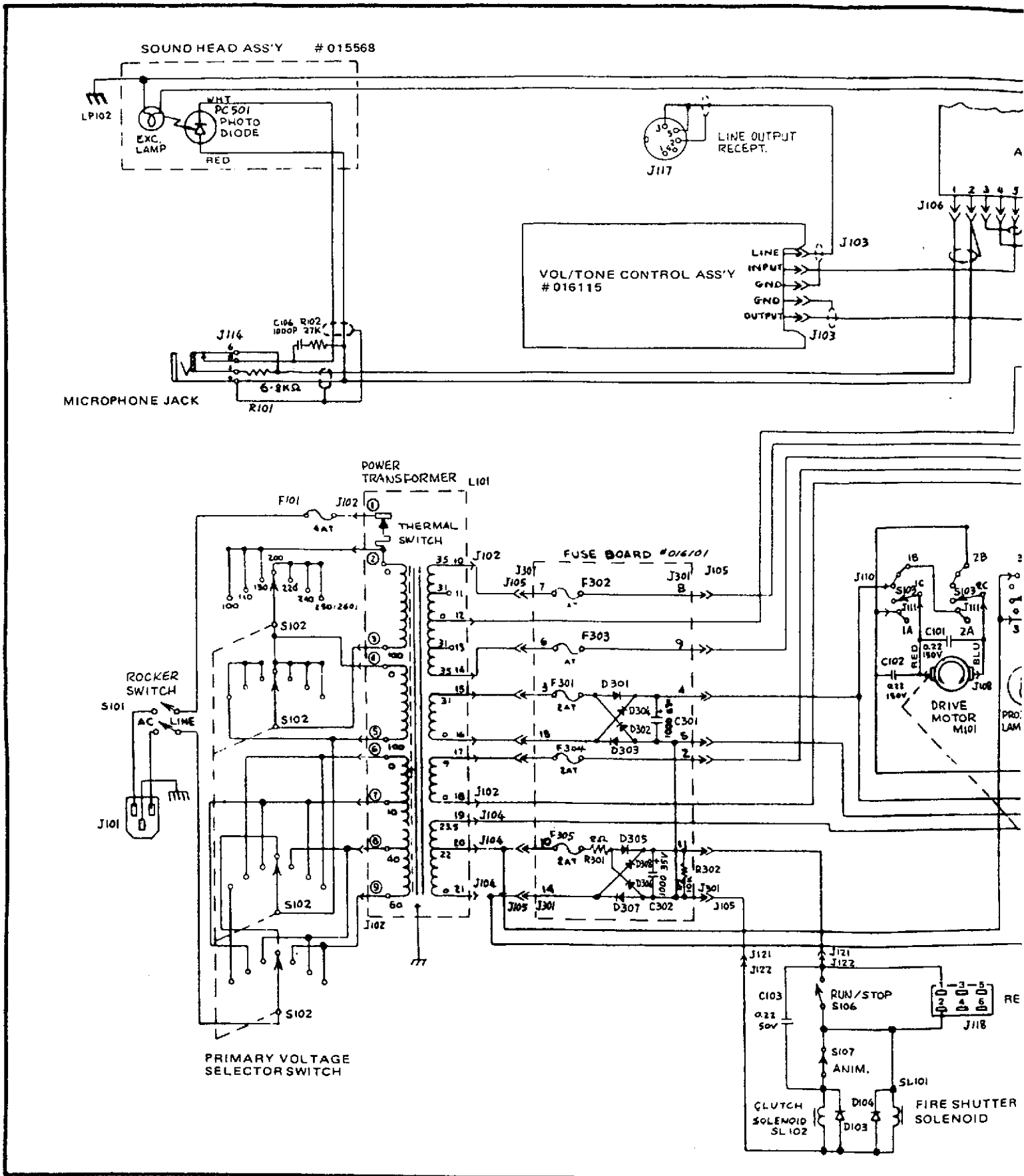
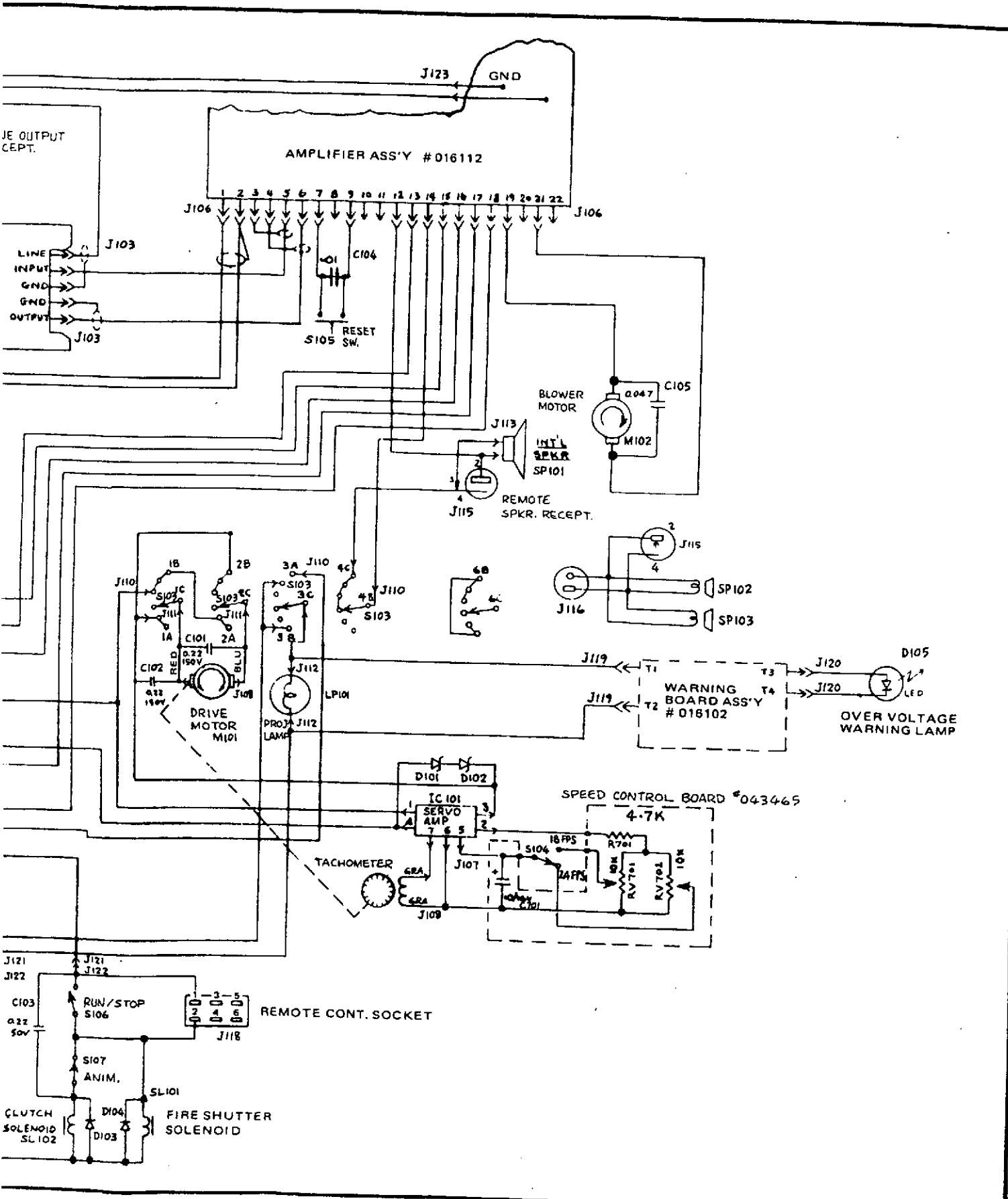

Figure 42. Projector Schematic



Schematic Diagram Des. 1695

Figure 41.
 DES 1695
 NEW PICTORIAL WIRING
 DIAGRAM
 FROM SERIAL NUMBER
 6223007

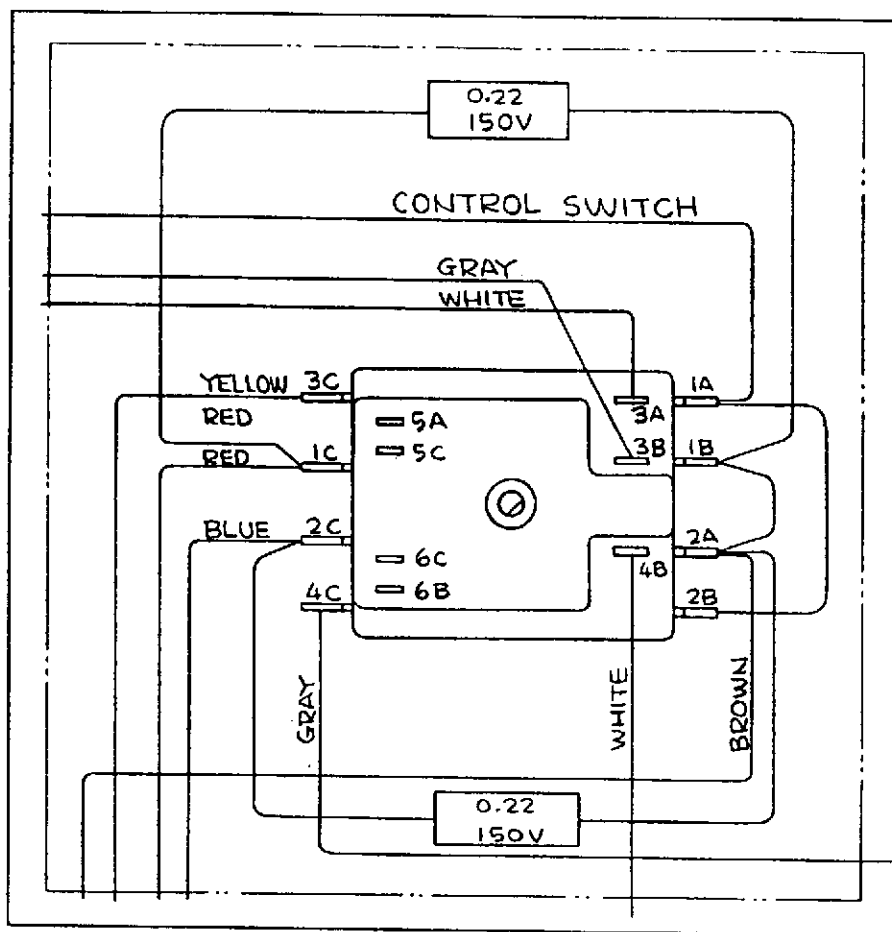
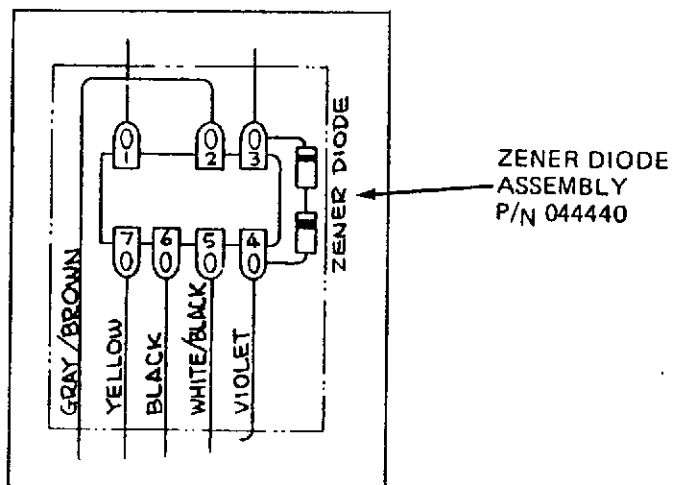
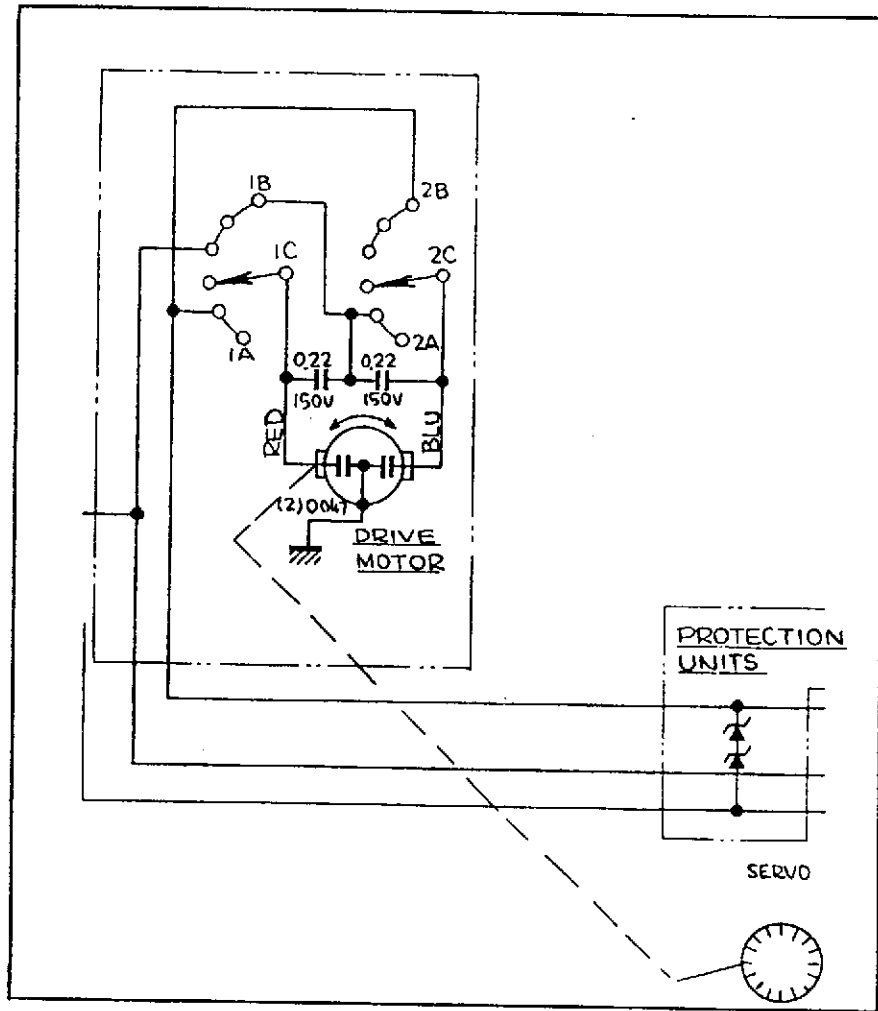

Figure 42.
DES 1695
NEW SCHEMATIC
FROM SERIAL NUMBER
6223007



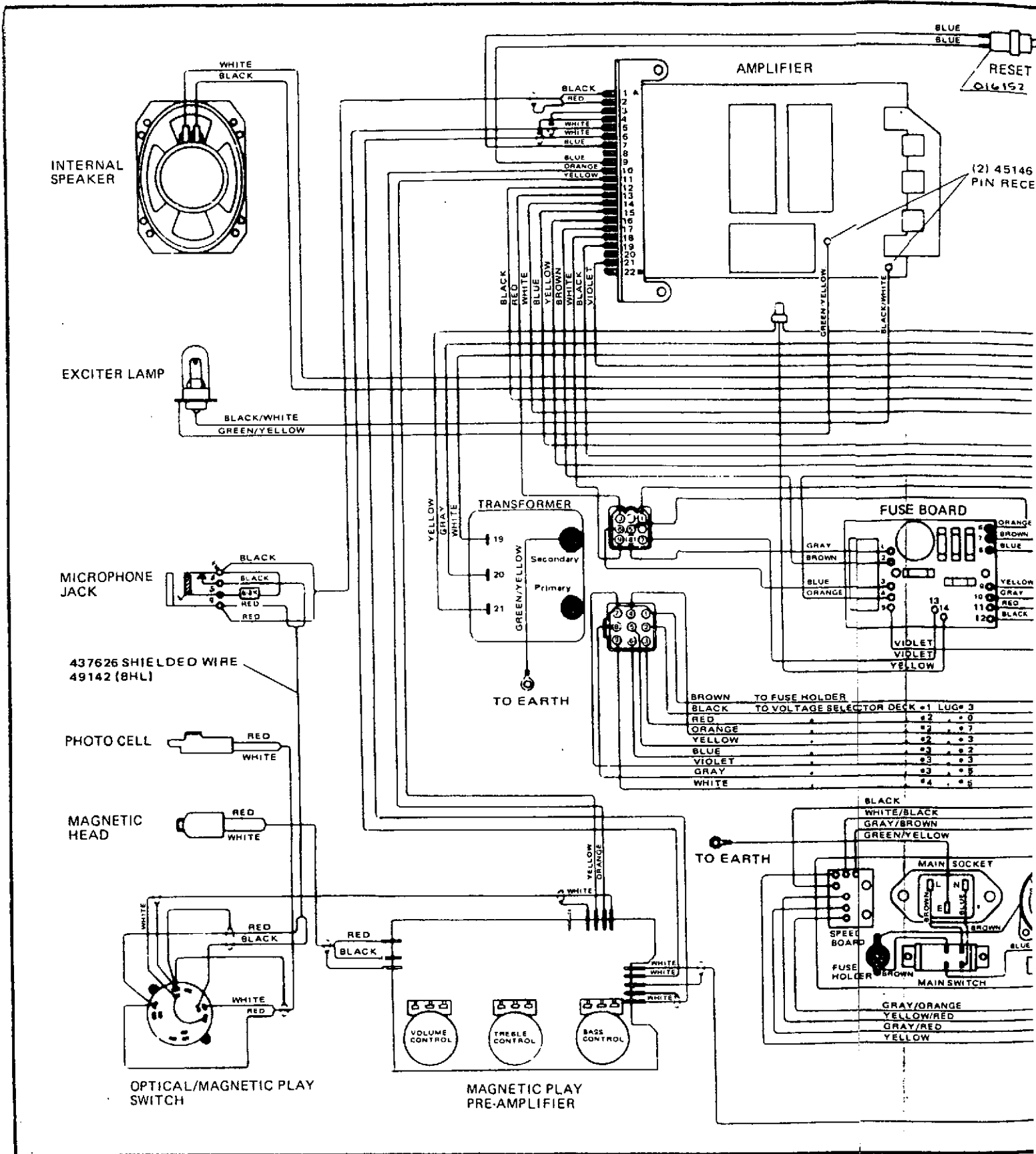
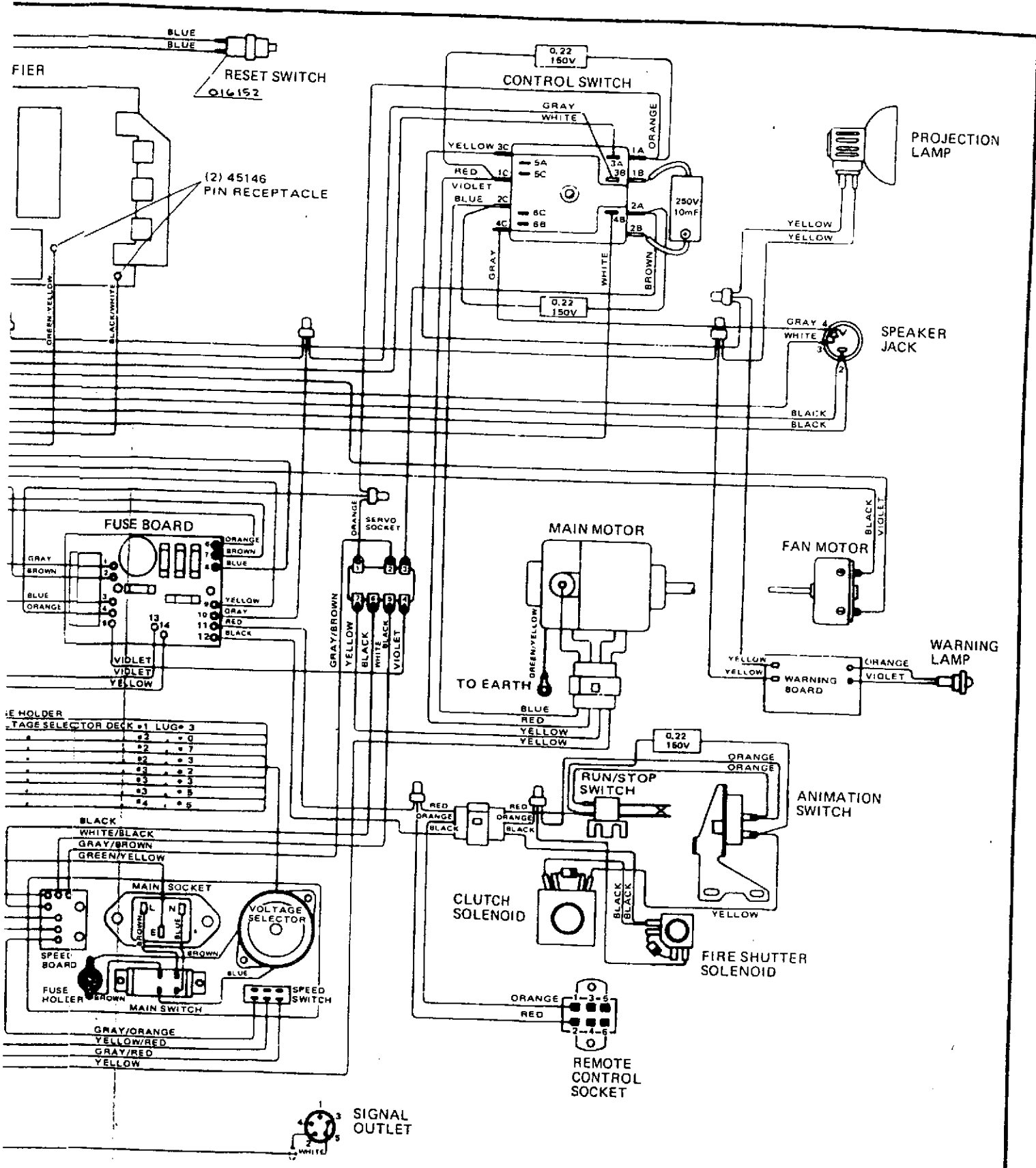

Figure 43. Pictorial Wiring Dia



Wiring Diagram

Des. 1698

Figure 43.
 DES 1698
 NEW PICTORIAL WIRING
 DIAGRAM
 FROM SERIAL NUMBER
 6223007

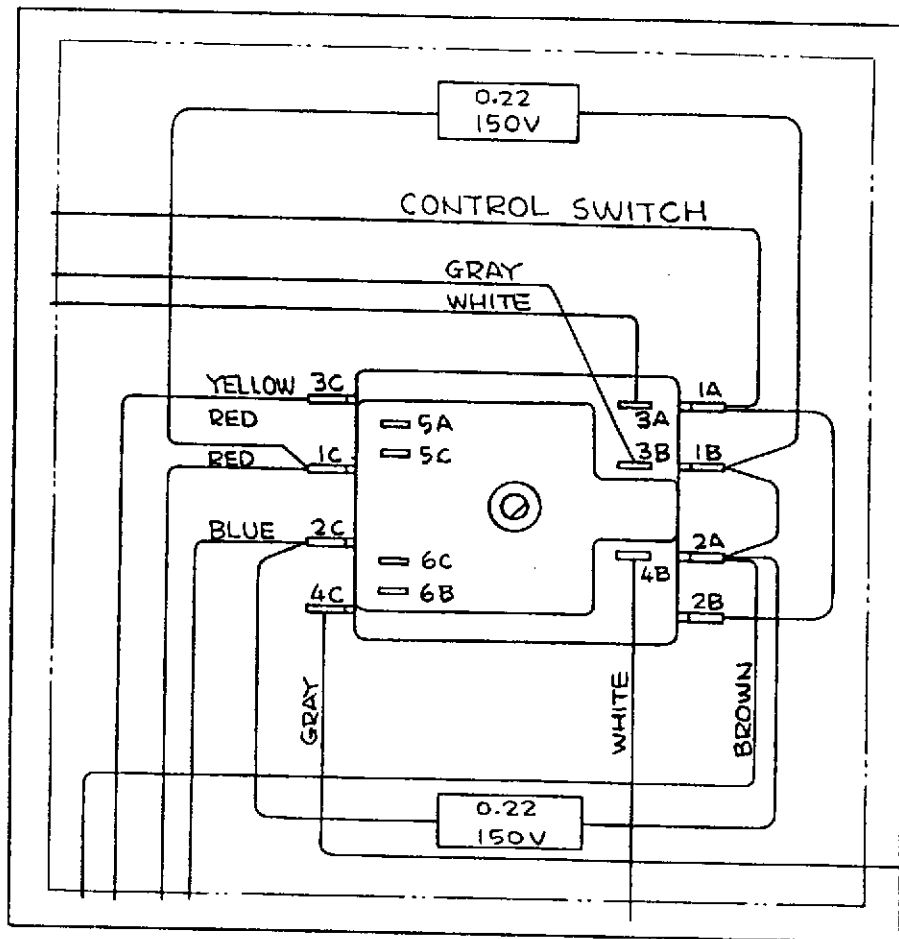
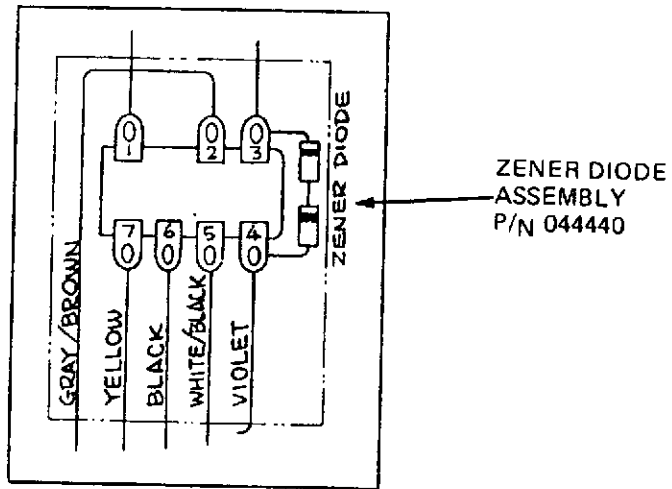
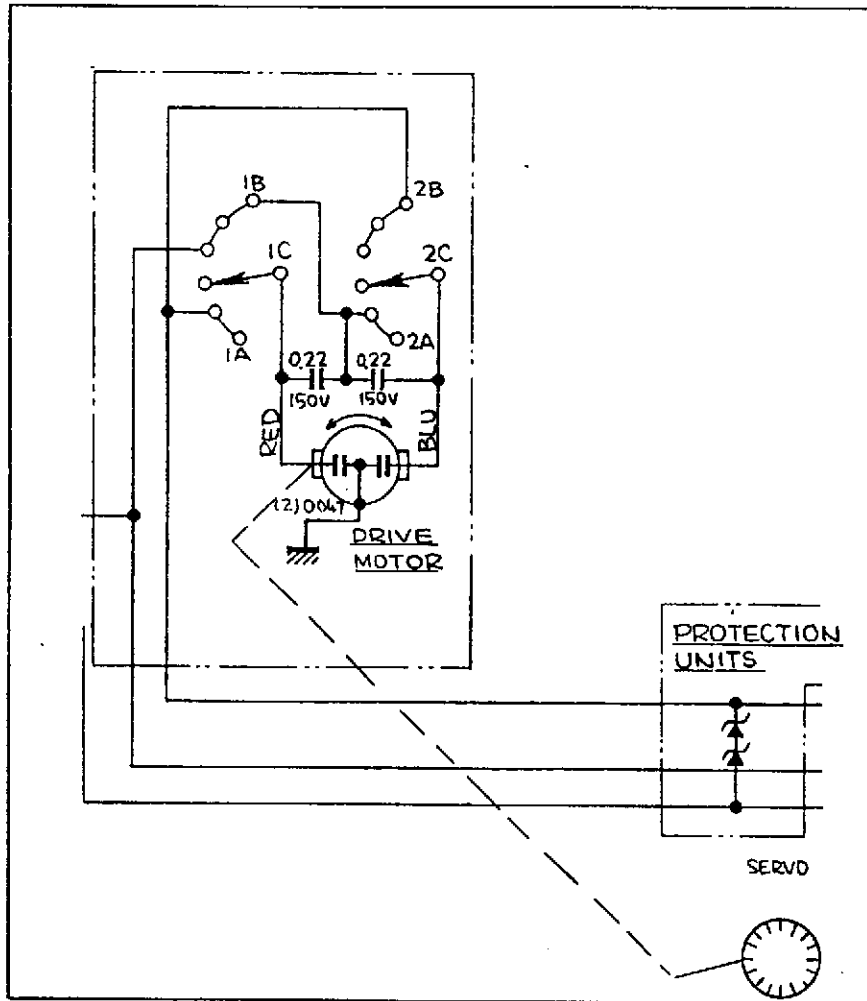

Figure 44.
DES 1698
NEW SCHEMATIC
FROM SERIAL NUMBER
6223007



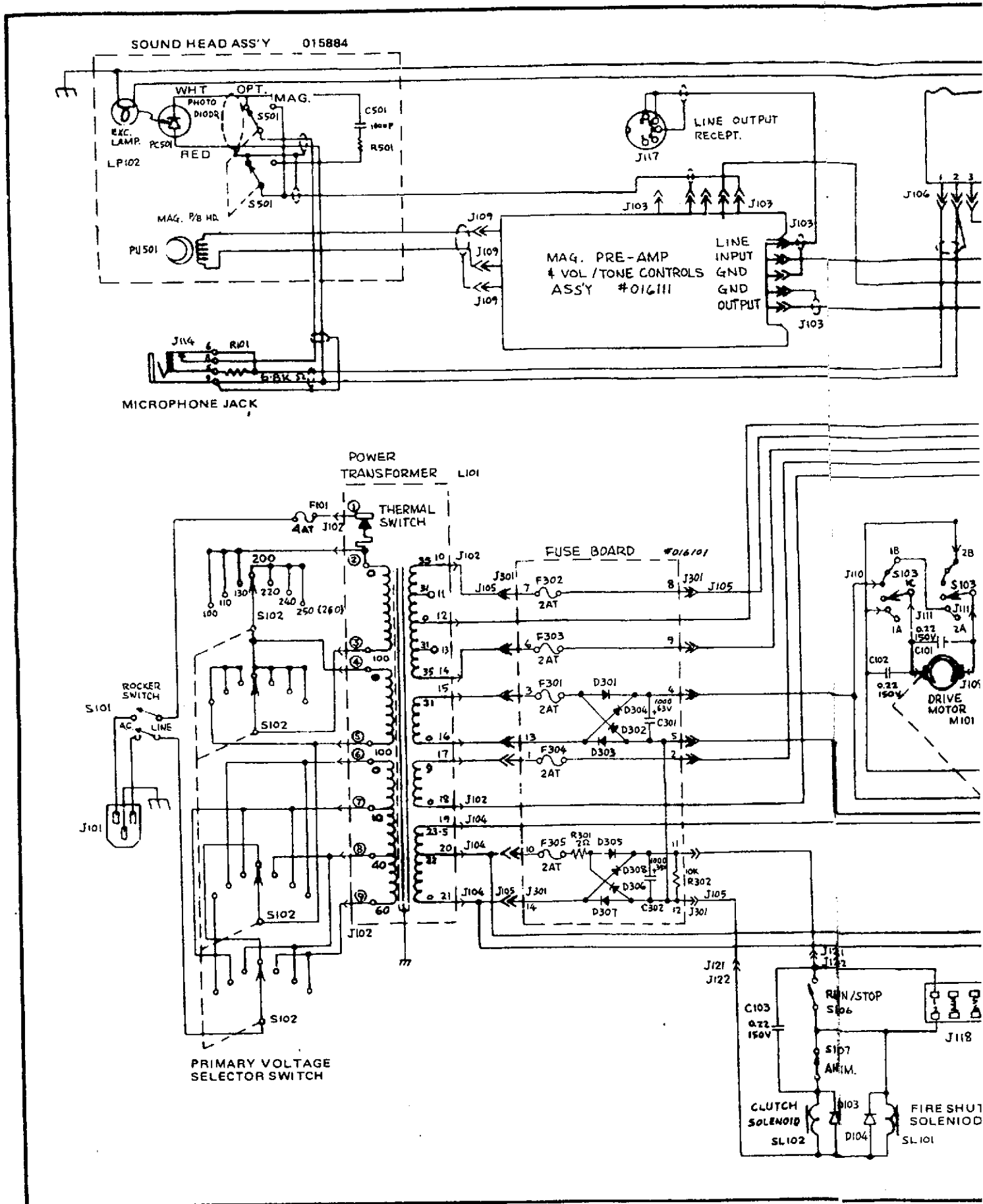
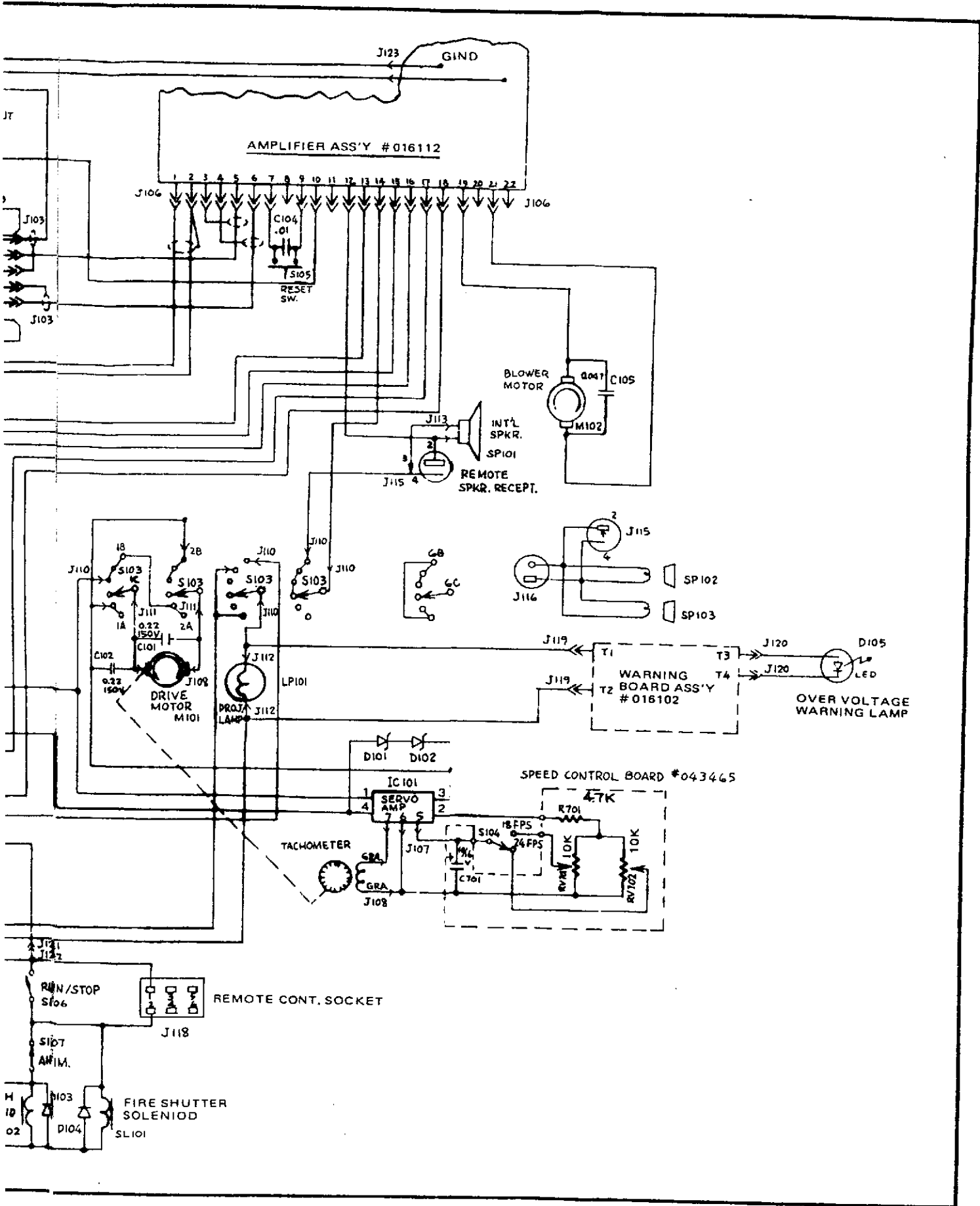

Figure 44. Projector Schematic



Schematic Diagram Des. 1698

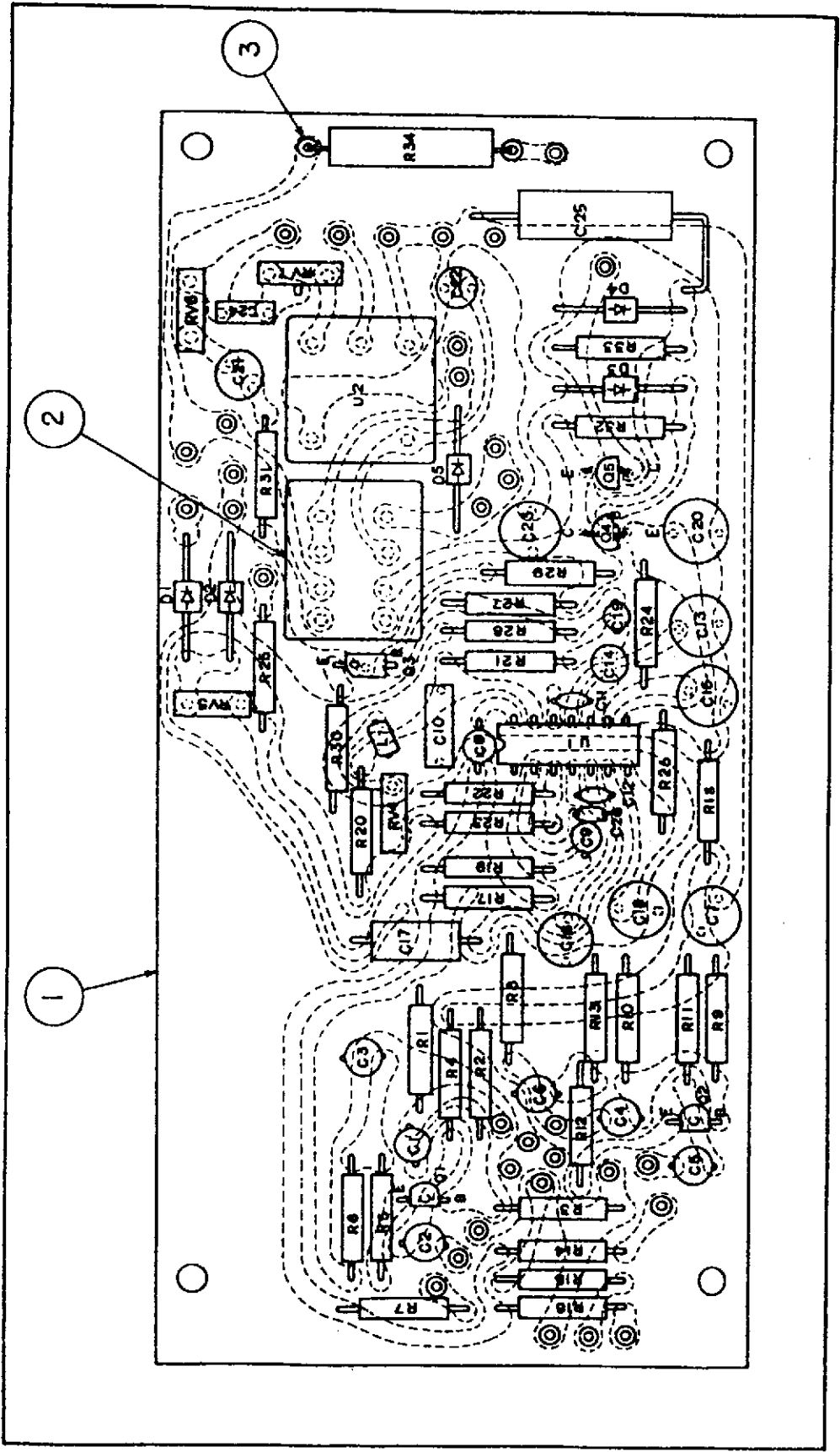

Figure 46. Recording Unit P.W.B. Assembly

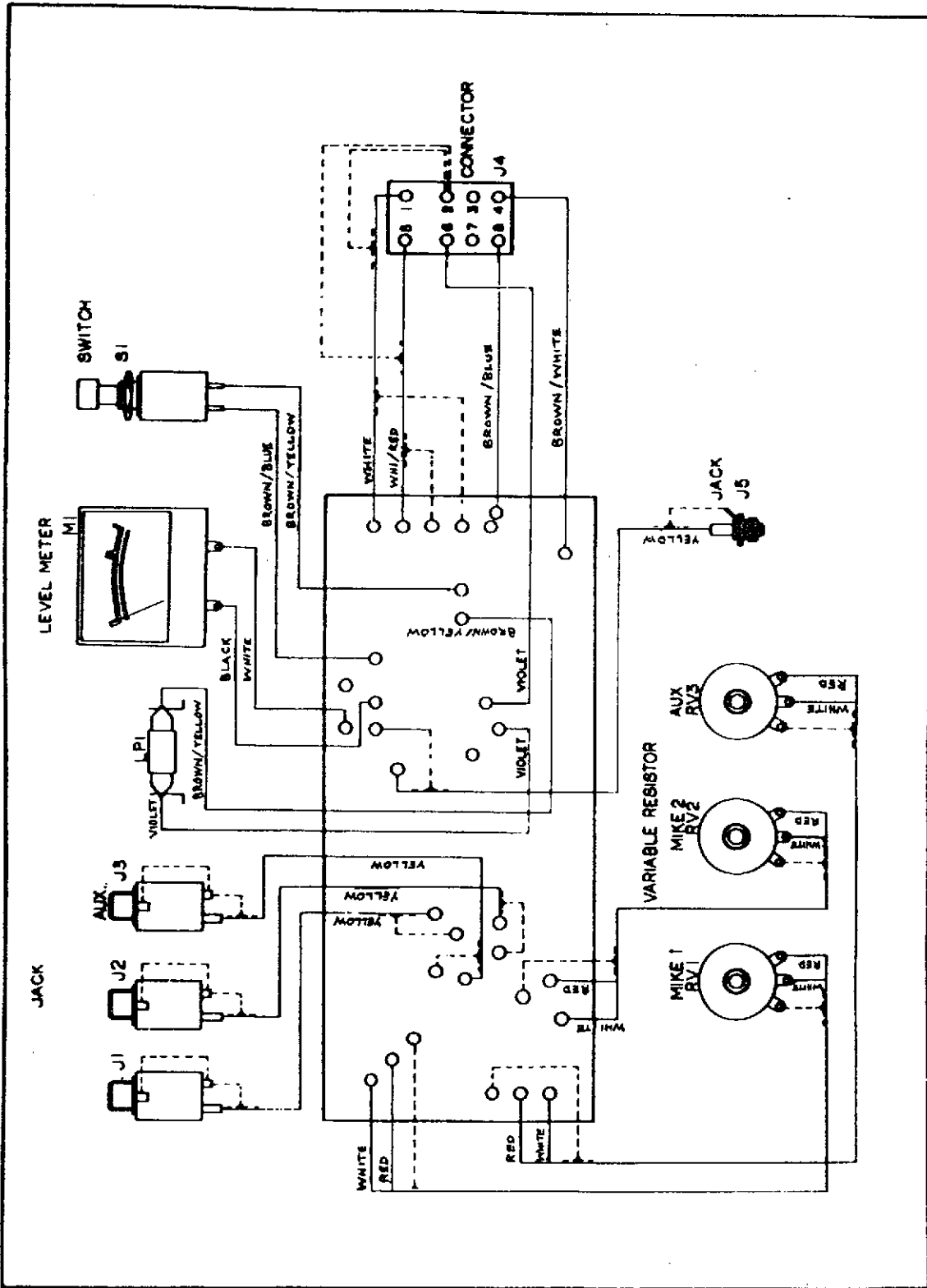

Figure 47. Pictorial Diagram P.W.B. Assembly

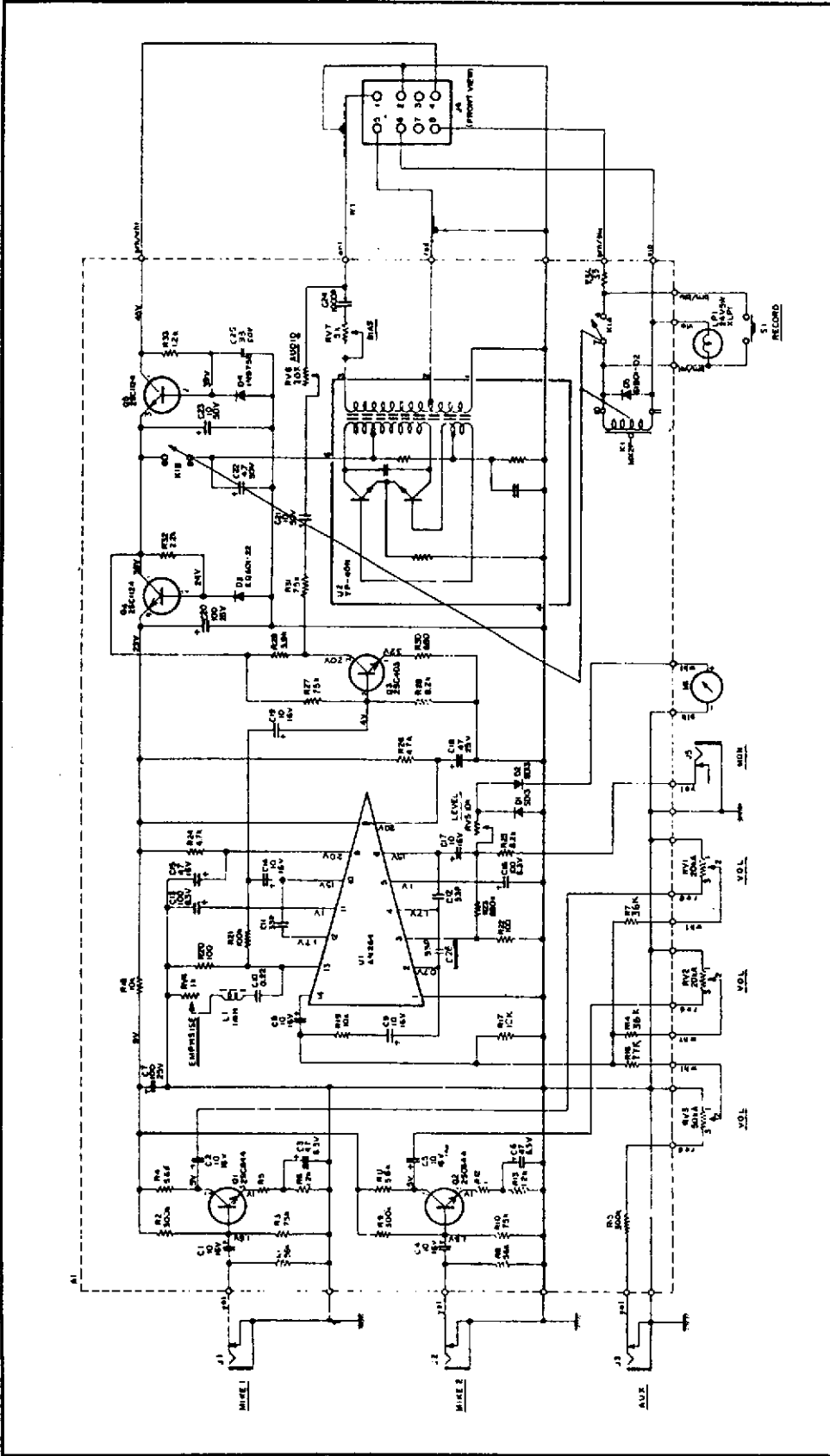

Figure 48. Schematic Circuit Diagram Recording Unit (1694)