

FILM-TECH

THE INFORMATION CONTAINED IN THIS ADOBE ACROBAT PDF FILE IS PROVIDED AT YOUR OWN RISK AND GOOD JUDGMENT.

THESE MANUALS ARE DESIGNED TO FACILITATE THE EXCHANGE OF INFORMATION RELATED TO CINEMA PROJECTION AND FILM HANDLING, WITH NO WARRANTIES NOR OBLIGATIONS FROM THE AUTHORS, FOR QUALIFIED FIELD SERVICE ENGINEERS.

IF YOU ARE NOT A QUALIFIED TECHNICIAN, PLEASE MAKE NO ADJUSTMENTS TO ANYTHING YOU MAY READ ABOUT IN THESE ADOBE MANUAL DOWNLOADS.

WWW.FILM-TECH.COM

SERVICE MANUAL FOR EX 5020SPECIFICATIONS FOR EX 5020

Power source	:	115v, 60 Hz, 20 amps	
Xenon Arc lamp	:	1000 watts 3000 lumens 6000° K (color)	
Optimum current	:	DC 45 amps (1000 hrs.)	
Maximum current	:	DC 50 amps (600 hrs.)	
Amplifier	:	solid state integrated circuit, 35 watts RMS	
Preamplifier	:	one transistor for magnetic head	
Sound source	:	optical--solar cell magnetic--100 mil head (full track)	
Monitor speaker	:	7" built-in	
Film speed	:	24 and 18 fps <i>FORWARD ONLY</i>	
Reel arms	:	5000' reel capacity	
Lens	:	2" f/1.3 standard	
Motors	:	one 1/20hp for film drive one 1/25hp for lamp cooling one 1/25hp for rectifier cooling	
Wow and flutter	:	Less than 0.18%	
Frequency response	:	40--7000 c.p.s. \pm 3 d.b.	
Optical	:	40--7000 Hz \pm 3d.b.	
Magnetic	:	40--10,000 Hz \pm 4 d.b.	
Exciter lamp	:	BRK (4v--0.75 amp D.C.)	
Dimensions	:	Height 69" to supply spindle Width 33" to take-up spindle Depth at base 15"	
Weight	Projector	:	69 pounds
	Rectifier w/base	:	132 pounds

Item Discussed			
Claw	S.1.1,S.1.4,S.1.5	Idler Rollers	S.6, S.7
Stop Lever	S.1.2	Loop Restorer	S.8
Worm Gear	S.1.3	Film Gate	S.9
Cam Tank Removal	S.1.6	Lens Holder	S.9.4
Cam Tank Repair	S.1.7	Sound Pick-up	S.10
Take-up Arm	S.2.2	Sound Drum	S.11
Gears	S.3	Speed Change	S.13
Cam Clutch	S.4	Cooling	S.12, S.14
Sprockets	S.3	Lamp and Mirror	S.15
Sprocket Shoes	S.5	Amplifier	S.16, Schematics

GENERAL NOTES ON SERVICING INTERNATIONAL PROJECTORS:

- A.** Metric Thread screws, standard throughout the world, are used in all International projectors. We offer an assortment of screws, nuts, bolts, washers, drills, and taps for your convenience.
- B.** Most repairs and adjustments can be made on International projectors using two sizes of Phillips screwdrivers, a blade screwdriver, and standard 16mm film as a thickness gauge. (Most 16mm film is about .005" thick.) To avoid damage to screw heads, it is important to remember the adage, "Use 80 per cent push, 20 per cent turn."
- C. Lubrication and Cleaning**
- Lubrication is normally not required for average operation. It is recommended that once a year or every 1000 hours, whichever occurs first, the moving parts be inspected for signs of excessive wear cleaned and lubricated.
- Use methyl hydrate, alcohol or tri-chloroethylene as cleaning agents. We do not recommend carbon tetrachloride due to the dangers involved.
- Polyurethane belts must be clean and dry. Remove oil and dirt accumulation with cloth moistened with cleaning agent.

Ball bearings should be clean and roll smoothly. If bearings are noisy or do not roll freely, they should be replaced. Shafts without ball bearings should be clean and lubricated with silicone fluid or a light smear of silicone compound. Remove excess.

Rollers must rotate freely. Shafts and inside surface of rollers must be clean, free from burrs, scratches or other defects. Lubricate sparingly with a light silicone oil or other fine oil. Remove excess.

Camtank shutter assembly is packed with silicone compound, Dow Corning No. 44 or equivalent. Use approx. 1 teaspoonful around fiber cam.

Shutter pulley cone clutch surface and surface of shutter blade hub should be clean and dry. Use light silicone oil or fluid to lubricate bronze bushing in shutter pulley.

Fiber gears must not be allowed to run dry. Use light silicone oil or other light fine oil and cover all teeth with oil. Wipe off excess. This treatment will generally last many thousands of hours.

S.1 CAMTANK ASSEMBLY (Shutter Claw and Clutch) X5-11001

S.1.1 CLAW ST-11191

Function: 2 tooth claw is made of extremely hard material, precision ground for maximum efficiency.

Face of claw teeth are ground at a slight angle. Claw then loses contact immediately as it begins to retract. Film then rests undisturbed till next pulldown.

Check: Claw screws must be tight, Do not overtighten! Claw lever is made of aluminum.

Adjustment: Holes in claw are slightly oversize. Angle of claw teeth may be adjusted slightly by loosening screws and tilting claw.

Claw angle may be further adjusted if necessary by bending claw lever in flat area. Use a pair of long-nosed pliers with a right angle bend.

S.1.2 STOP LEVER ST-11301

Function: When FULLY depressed, assembly is placed between lamp and aperture. This action also moves shutter, compressing spring ST-11141. This releases shutter pulley, allowing it to rotate freely on shaft. Special shoulder screws ST-11271 are used to mount stop lever.

S.1.3 WORM GEAR X1-11501

Check: Worm gear must be mounted and secured to eliminate any "end play" of shutter shaft.

Camtank assembly must be mounted so that there is a small amount of "play" between worm gear and fibre gears. Rotate fibre gears to check.

Adjustment: Reposition as necessary and tighten screws securely.

S.1.4 CLAW POSITION

Check: Claw must enter film perforation, refer to section S.9 dealing with gate adjustments.

Claw must not touch sides of perforations at any time during its entry, pull-down or exit.

Claw should leave film so that frame is centered over aperture with framing lever in midway position.

Adjustment: Slightly loosen 2 screws that hold fulcrum collar horizontally and/or vertically to correct position.

Check: Check for correct framing with film in projector and operating.

S.1.5 CLAW PROTRUSION

Check: Claw protrusion should be $.040'' \pm .005''$. Use gauge to determine.

Adjustment: Remove cover X5-32361. Turn inching knob so that claw is fully retracted.

Use claw adjustment tool to carefully bend claw lever. Be sure claw is not touching film gate during bending. Claw breakage could result.

Check: Horizontal position of teeth is affected by protrusion adjustment. Recheck and readjust as necessary.

NOTE: Claw protrusion may be affected by camtank position when reinstalling. Check and reposition camtank if necessary.

S.1.6 CAMTANK ASSEMBLY REMOVAL

- a) Remove cover X5-32361
- b) Remove rear cover.
- c) Remove shutter pulley belt.
- d) Turn inching knob to fully retract claw.
- e) Depress stop lever halfway.
- f) Remove 2 mounting screws.
- g) Remove assembly, being careful not to damage claw.

NOTE: When installing, be sure to provide a small amount of "play" between worm gear and fibre gears.

S.1.7 CAMTANK DISASSEMBLY

- a) Depress stop lever halfway.
- b) Remove screw in end of shaft.
- c) Remove plate washer ST-11351 and pulley.
- d) Raise stop lever and remove shutter blade and hub.
- e) Depress stop lever part way to expose 4 heads of cover plate mounting screws and remove screws.
- f) Remove cover.

- g) Observe location of fiber cam and springs inside claw lever:
 --Curved shock absorber spring ST-11161 is at top, in "hump"
 --Straight spring ST-11151 is next.
 --Cam rotates between this and another ST-11151 at bottom of hole.

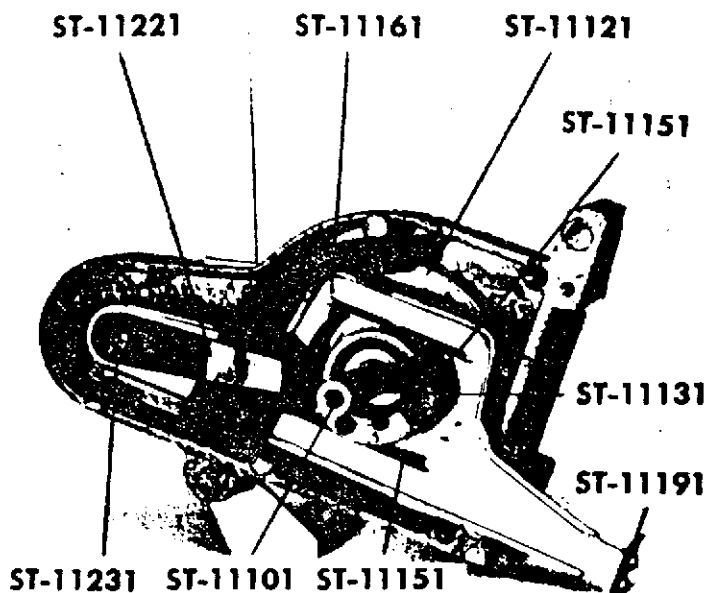

- h) Felt spring ST-11211 is used to hold felt in place as well as provide side tension to keep claw lever against cam plate.
 i) Hole in felt spring fits OVER fulcrum pin. When reassembling be sure that spring is not jammed between end of fulcrum pin and washer ST-11231.
 j) Shaft X5-11101 should have no end play. Worm gear must be installed without clearance.
 k) Ball bearings must be free from any play. Replace if necessary.
 l) 2-bladed shutter is mounted to hub ST-11281 so that raised semicircle of hub is facing one blade. (3-bladed shutter is automatically correct.) Shutter blade is depressed in centre to offset blades. Hub is inserted into hole of blade from depressed side.
 m) Shutter blade has elongated mounting holes. Travel ghost is at a minimum normally if blade is mounted with holes centered. If necessary, move blade slightly to overcome travel ghost.

- n) Further timing is predetermined by fibre cam mounting screws placed in an "off centre" position.
 o) Lubricate fibre cam area with silicone grease. Use approximately 1 teaspoon.
 p) Shutter pulley must be clean and dry on both sides.
 q) Shutter shaft must be clean.
 r) Lubricate bronze bushing of shutter pulley and shutter shaft with a small amount of silicone oil.

AVOID OVERLUBRICATION

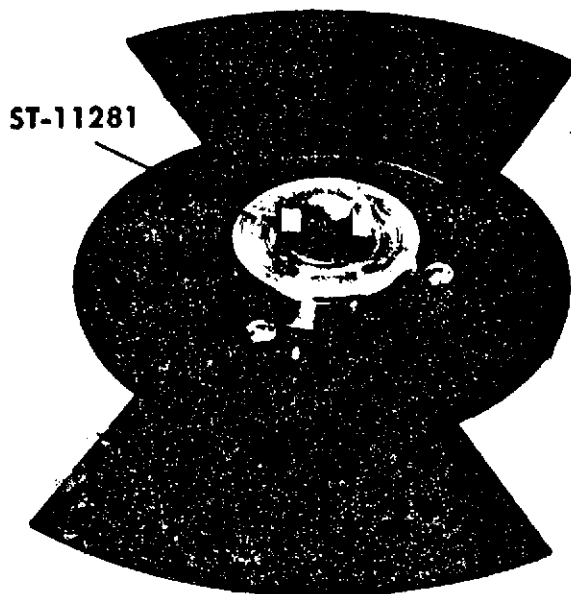

S.2 REEL ARMS

- S.2.1 Upper (Supply) - Arm is mounted on top of projector head and secured by two screws.
 S.2.2 LOWER (Take-Up) - This lower take-up arm is mounted on the bottom of the projector head bracket X5-14431 is mounted to the base of the projector head. The arm then is mounted onto the bracket with a Philips screw and a wing nut. This arrangement allows the arm to be swung forth and back to accommodate different size reels or when tilting the projector head up for inspection of the amplifier area.

S.2.3 Slip Clutch - The spindle drum, is lined with a cork or felt liner. This acts as a slip clutch arrangement over the spindle drum. There should be some clearance between the spindle drum and liner and the plastic drum. The automatic action of this clutch provides adequate take-up operation, as the weight of the film on the take-up reel increases, the friction also increases, thus driving the reel and keeping a relatively uniform wind on the film.

S.3 DRIVE GEARS & FILM SPROCKETS

S.3.1 When assembling the sprocket shaft and fibre gears, care should be taken to allow .003" end play. Use a fine lubricating oil SPARINGLY on the bronze bushings and shaft. Observe the flat spots on the shaft for the purpose of tightening the gears, collars, etc. The shaft should be "rocked" back and forth before the final turn of the tightening screw. Be sure the screw is perpendicular to the flat spot on the shaft.

S.3.2 Sprocket tooth position is adjusted by loosening screw in end of shaft, thus releasing the pressure of the face plate against the sprocket plate. Observe position of film in relation to loop restorer roller. If film tends to strike roller during projection, rotate #2 sprocket plate counter-clockwise 1/3 - 1/2 frame. Tighten screw. Perpendicular film movement midway between sound drum and #3 sprocket should be approximately 3/16". Adjust #3 sprocket if necessary, for proper film tension over sound drum.

S.4 CAM CLUTCH

S.4.1 Rewind: This clutch is part of the #1 sprocket and gear shaft assembly. See parts list. This clutch engages when the film direction is in REWIND. This is necessary to rewind the film on the supply reel. When assembling, turn or position the gear so that the protruding pin

in the hub of the gear is in the "1:30 o'clock" position. Hang the curved cam ST-14071 on the pin. Place clutch pulley X5-15501 on shaft. Install retaining collar ST-15141 fastening the screw on the flat spot of the shaft. Be sure to allow a slight amount of "end play" on the shaft, approximately .003".

S.4.2 CAUTION This machine is not intended to rewind a large reel of film. The rewind facility is provided only for the use of small reels, such as 400' type.

S.5 SPROCKET SHOES:

S.5.1 The sprocket shoes prevent the film from skipping over the sprocket. The oversize holes in the shoe mounting bracket allow for proper positioning of the shoe in relation to the sprocket. The stationary roller should clear the sprocket by approximately .015" - .020". This will allow the film to be threaded easily without damage. The moveable roller should be as close as possible to the sprocket (without a film), and yet be free to turn.

S.6 IDLER ROLLERS:

S.6.1 Idler rollers must turn freely. Use oil SPARINGLY.

S.7 TENSION ROLLER ASSEMBLY X1-17941.

S.7.1 This roller, is between the sound drum and the #3 sprocket. The tension at the roller should be approximately 2 1/2 oz.

S.7.2 Remove flywheel and #2 fibre gear to provide access to spring tension adjustment.

S.7.3 To adjust, loosen spring bracket, on rear of shaft and move as necessary to achieve the correct spring tension. Tighten screw securely. See also S.3.2.

S.8 AUTOMATIC LOOP SETTER X1-18001

S.8.1 This device maintains the correct lower loop size. As the loop is lost the film applies pressure to the sensing roller ST-18021. This causes it to begin a counter-clockwise revolution. The rubber tire X1-18071 at the rear of the shaft then engages the #2 fibre gear causing the loop setter to make a complete revolution. The sensing roller should stop at the 3 o'clock position. Adjust bracket ST-18031 as necessary.

S.8.2 The tension spring between the rubber wheel and case holds the loop setter in neutral position. If loopsetter does not stay in neutral, and keeps rotating, adjust by sliding rubber wheel closer to case, thus increasing the spring tension.

S.8.3 Adjust sprocket plates as necessary as per S.3.2.

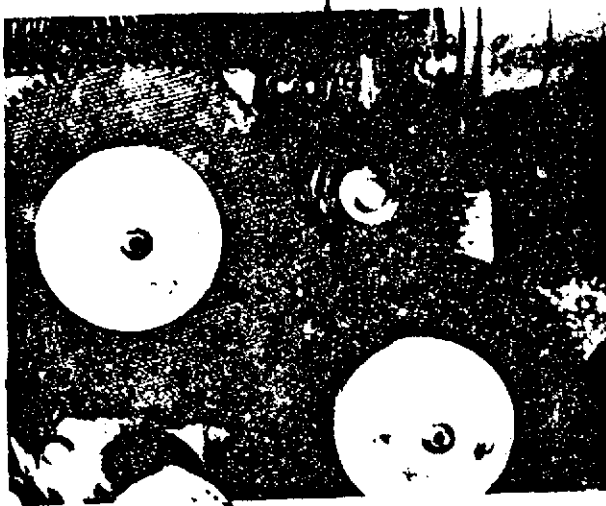

S.9 FILM GATE ASSEMBLY X1-31001

S.9.1 Outer Guide Rail ST-31071 is secured to gate plate by 2 screws and located against shoulder of film gate ST-31101. This assures proper vertical travel of film, parallel to film gate. Diagonal travel of film may cause picture or sound track portion of film to touch raised sections of film gate. Film damage will result.

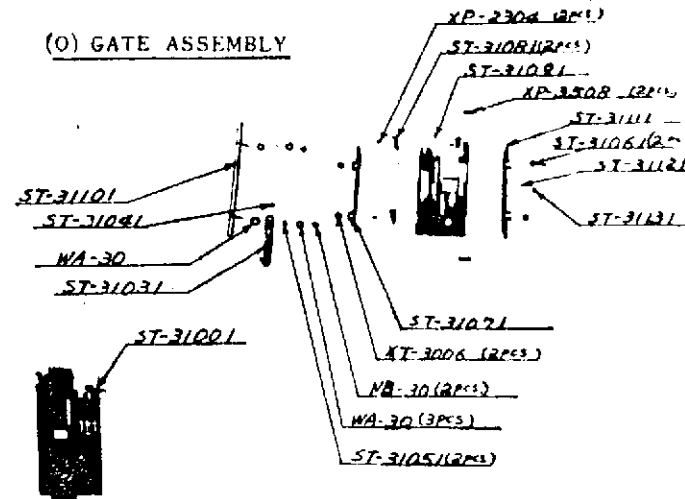

S.9.2 Inner Guide Rail is spring loaded, and held in place by 2 shoulder screws ST-31061. With screws secured, guide rail should be free to travel with a minimum of clearance under screw head. Spring tension must be sufficient to hold film against outer guide rail, thus establishing side tension on edge of film. Check for additional clearance of inner guide rail to accommodate wider film or scotch tape wrapped around film.

S.9.3 Film shoe is mounted on 2 pins and held in place by a locking lever under lower pin. Retaining plate ST-30041 is secured to lens holder by 2 screws. Holes in lens holder are oversize, allowing for adjustment of film shoe position.

Check: Outer guide rail must be snug against shoulder of film gate. Swing lens in to close gate. Clearance between outer guide rail and outer edge of film shoe should be the thickness of 1 film.

Adjustment: Cut a 4" length of 16mm film $\frac{1}{2}$ " wide. Insert between film shoe and outer guide rail. Film shoe should be moderately snug. If adjustment is required, loosen 2 screws that hold retaining plate ST-30041. Reposition plate and tighten screws. Shoe must not bind on guide rails.

Check: Be sure pins do not bind when fully depressed in lens holder. With gate closed and lens removed, check that hole in film shoe clears the film aperture on all sides.

NOTE: Lower shoe pin spring ST-30071 is longer than upper spring ST-30061. Extra tension is designed to overcome film movement caused by claw action at lower end of film shoe.

S.9.4 LENS HOLDER ASSEMBLY K5-30201

Check: Optical axis of lens must be perpendicular to film plane. Set projector at exact right angles to screen. Without film, project light beam. A 3' wide area is a good size. Both side edges of illuminated area must be focused, equally sharp.

Adjustment: Loosen lock nut and adjust screw located under front of lens holder to achieve optimum equal focus. Tighten lock nut.

NOTE: The Super F1.3 high speed lens has a shallower depth of focus and requires a more accurate adjustment than other slower lenses.

S.10 SOUND PICK-UP

S.10.1 Function: The focus and azimuth of the optical sound lens are very critical and are adjusted simultaneously. Note position of filament of exciter lamp. It must be in center line of optical lens. The scanning beam must be a sharp thin line focused on the film sound track. The scanning beam must also strike the center of the sound track. In this position it will clear the edge of the sound drum and strike the solar cell.

S.10.2 Check: A frequency test film should provide a good response up to 6000 or 7000 Hz. A normal sound test film should produce enough high frequency tones for a pleasant sound balance.

Adjustment: To adjust optical lens for focus and azimuth it is necessary to use a test film with a 7000 cycle tone. SMPTE PH 22.42--7000 is such a film. A 3-foot length of this film

should be spliced to form a loop. Installed in the projector it will provide the necessary signal for accurate adjustment. Remove exciter lamp cover for any adjustments to optical lens.

Install a 8-ohm 10-watt resistor across speaker output. Connect a low reading AC voltmeter and an Oscilloscope across resistor, with projector operating, set meter and scope for convenient reading with volume control at approx. "9 o'clock" ($\frac{1}{2}$ rotation) and treble control at maximum. Loosen screw in lens holder bracket X1-40011, thus allowing lens to be moved. Rotate lens for azimuth adjustment. Observe clean sine wave pattern on oscilloscope. Set for maximum reading. Slide lens forth and back for focus. Observe meter reading or oscilloscope amplitude. Set for maximum reading on both azimuth and focus with simultaneous adjustment, tighten screw to clamp lens. Observe meter or scope. Output should not drop. Seal set screw with paint.

S.10.3 Check: Scanning beam must fall on center of optical sound track of film. Excessive noise will be heard together with distorted sound if scanning beam position is incorrect. Use SMPTE "Jiffy" test film to check. It contains a section of Buzz Track test film.

Adjustment: To adjust, use SMPTE PH 22.57 Buzz Track Test Film. A 3-foot length to form a loop is convenient. (SMPTE "Jiffy" test film may be used.) The guide roller ST-17231, just above the sound drum is adjustable horizontally to guide the film so that the scanning beam strikes the sound track properly. A test film is available from the Society of Motion Picture Engineers to assure proper alignment. (SMPTE Buzz Track PH22.57). Loosen set screw on collar behind roller and slide roller horizontally until no sound is heard. Too far in one direction produces a low tone, other side produces a high tone. Tighten set screw after adjustment.

S.10.4 Be sure lens is clean.

S.10.5 Use BRK 4 volt 0.75 amp exciter lamp. Using lamp with filament in opposite orientation results in loss of high frequency and distorted sound.

S.10.6 The solar cell is located in the casting collar XI-41031, just under the edge of the sound drum. Remove the leads from the terminal strip before removing the housing. After the housing is replaced, be sure that solar cell is in line with the optical lens. The Scanning beam must fall on the cell.

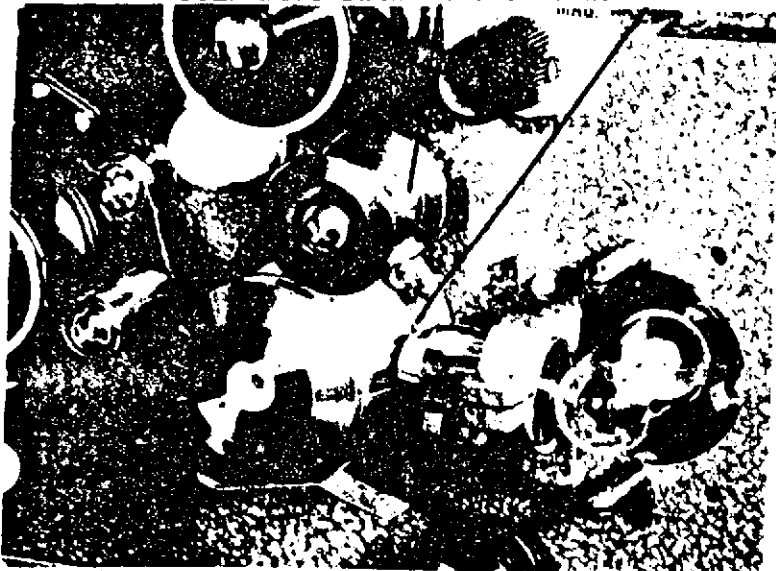

S.10.7 This projector has a magnetic head and associated switch and circuit for magnetic playback. In the OPT position, the wafer contacts connect the solar cell circuit and exciter lamp circuit to the amplifier. The magnetic sound head is lifted off the film by the action of the lever attached to the end of the switch shaft. The sound head is directly behind the sound drum. The bracket and shaft assembly is spring loaded so that when the selector switch is in the MAG. position, the spring pulls the magnetic sound head down in contact with the magnetic sound strip on the film. In the OPT position, the switch lever strikes the sound head shaft bracket, lifting it up. Observe this action and adjust the position of the switch lever if necessary. This is done by releasing the set screw in the end of the switch shaft. Wafer contacts must make full contact in either selector switch position.

S.10.8 NOTE: Selector switch should be in MAG. position when removing and replacing sound drum. This will avoid bending magnetic head bracket.

S.11 SOUND DRUM AND FLYWHEEL ASSEMBLY

S.11.1 The sound drum shaft is mounted in the shaft housing, with ball bearings. The retaining collar should be installed with .002" clearance. Shaft must not bind in rotation. Flywheel should be secured so as not to allow it to slip or loosen.

S.11.2 NOTE - MAG. - OPT. switch must be in MAG position when removing the sound drum shaft.

S.12 MOTOR AND COOLING FAN

S.12.1 When mounting motor and fan observe the clearance on either side of cooling fan. Tighten set screw securely,

S.12.2 Be sure to install belt pulley on motor shaft before mounting motor and fan housing to projector chassis. After securing motor mounting, align the motor belt pulley with the idler pulley. Tighten set screw to flat spot on motor shaft.

S.13 SPEED CHANGE

S.13.1 Sound Speed (24 frames per sec.) is obtained by placing the belt on the large size motor pulley.

S.13.2 For silent (18 frames per sec.) place the belt on the other pulley. Align motor pulley according to use.

S.14 LAMP HOUSE COOLING FAN

S.14.1 This is located underneath the lamphouse. Access may be gained to the belt by removing the large plate on the front of the projector under lamphouse door.

S.14.2 All bearings in motor and fan housing assembly are factory lubricated and will normally not require any attention.

S.14.3 Pulleys must be aligned correctly for maximum belt life. Improper alignment causes the belts to oscillate.

S.15 LAMPHOUSE AND MIRROR

S.15.1 The lamphouse contains the mirror, the starter circuit for the lamp, and 2 micro switches. The starter generates a high frequency, high voltage starting pulse which is used to ignite the Xenon lamp. After ignition the lamp operates on direct current.

S.15.2 Directly ahead and below the mirror, will be seen micro switch that is air operated, so that if the cooling fan is not operating the lamp will not ignite.

S.15.3 Also connected to the lower corner of the mirror ring is another micro switch. This is actuated by a bracket on the small door. If this door is open, the lamp will go out or not be ignited. These 2 switches are in series.

S.15.4 CAUTION When lamp is on use a No. 10 dark welders glass when looking at the Xenon arc light. The harmful rays that are emitted from the highpowered light source are injurious to the eyes.

S.15.5 CAUTION Mirror is a front surface coated unit. DO NOT RUB EXCESSIVELY WHEN CLEANING. Use a soft cloth, moistened with alcohol or water, wiping gently.

S.15.6 CAUTION Xenon lamp has high internal pressure. Use safety helmet when removing or installing. Do not touch quartz bulb with hands. Wipe with soft cloth moistened with alcohol to clean.

S.15.7 Lamp is mounted with plus sign (anode) towards the front of the projector. When mounting lamp be sure that the locking nut on either end of the lamp are securely tightened, to ensure a good contact.

S.15.8 Focusing of the lamp is accom-

plished by three focus adjustment screws. These screws move the lamp sufficiently to centre it in the focal point of the mirror, thus giving maximum light output.

S.15.9 The cathode or negative end of the lamp is mounted in a bushing which is located in the lamp socket in the mirror assembly. If it is noted that the three adjustment screws do not provide an adjustment that is sufficient to move the lamp, into the focal point of the mirror, it might be necessary to move this bushing as a coarse adjustment. You will find a locking screw directly behind the fibre insulator. Loosen this screw to move the bushing to a relatively medium position. Be sure to tighten this locking screw after the coarse adjustment is made. It may be necessary to remove the lamphouse cover to accomplish this adjustment. Simply remove the four wing-nuts located inside the cover.

S.15.10 The fibre mounting bracket which is located under the front end of the lamp must be out of the way when operating the lamp. This fibre support is used only for a short transportation or for storage.

S.15.11 The magnet located under the mirror is used to stabilize the arc. This normally requires no adjustment.

S.15.12 A heat proof glass filter composed of 2 strips of quartz glass is located on the forward end of the lamphouse cover.

S.15.13 Focusing Lamp - When focusing the lamp in relation to the mirror, it is necessary to have no film in the projector. Swing the lens holder out, with the lamp turned on, rotate the adjusting screws so that a circle of light is seen on the screen area. The centre of this circle will be a dark spot. Adjust each of the three knobs a little at a time to make this black area in the center as small as possible without diminishing the light area around it. It may

be necessary to make a complete check with the focusing procedure, in that you will turn all the screws to a point where the general area becomes darker and you will note that you have passed the focal point. Turn the screws in the opposite direction until it becomes brighter and passed the bright uniform point back into the darker area. You will then be able to determine the best possible output of light by re-adjustment. After the adjustment of the screws, with the lens holder out, it will be necessary to check the uniform light distribution with the lens in place. Swing lens onto gate. Check the projected area for hot spots. If necessary a slight amount of adjustment on one or two of the screws may be required to re-distribute the light over the entire picture area.

S.16 AMPLIFIER

- S.16.1 To remove the amplifier unplug the necessary electrical connectors. The knurled hand knob in the centre of the chassis holds the amplifier to the projector base. With this removed the amplifier will be free to be moved out.
- S.16.2 In the event of sound problems, first of all check the fuse and other electrical connections. Refer to schematics for electronic checks and repairs.

XENON LAMP POWER SUPPLY

The following is an explanation of the Xenon lamp circuit. When the lamp switch is put to "on" position, there is AC power completed to the main power relay. The contacts close, providing power to the transformer. The secondary of the transformer is connected across a diode rectifier bridge. The output of this bridge, being DC, charges up the capacitors in the DC side of the circuit. When the voltage reaches approximately 60 - 65 volts, the relay in the starter circuit closes, thus energizing by its contacts the step-up transformer located on the starter. The secondary of this starter produces a high enough voltage to break down the spark gap. When the spark jumps across the spark gap, the secondary part of this transformer being connected in series with a condenser and the primary of the tesla-coil produces a high voltage, high frequency voltage. The secondary of the tesla-coil, which also acts as a transformer, produces a still higher voltage across the gap in the Xenon lamp. This voltage is on the order of 20-25,000 volts. As the gap is broken down in the lamp the Xenon gas ignites. When this happens, a current flows from the cathode to the anode, that is, from minus to plus in the lamp. When this current begins to flow and the Xenon gas is ignited, the resistance in the lamp decreases greatly. At this point, the voltage across the lamp drops down to approximately 22 volts. As the voltage drops down, the relay that is mounted in the starter drops out, therefore, disconnecting the line voltage from the primary of the step-up transformer. This removes any high voltage from the lamp. After ignition, the lamp will continue to operate at high current with only 20 or 22 volts across the lamp electrodes.

Connected to the transformer is a current control. On the EX5020 this current control is accomplished by moving a variable resistor which is in series with a saturable reactor. This provides very efficient current control with good regulation.

To trouble shoot this circuit, it is wise to disconnect the line voltage wires to the starter that are connected to terminals number 3 and 4. Now switch the lamp switch to "on" position, this should provide an open circuit voltage which can be measured across terminals 1 and 2 which are the black and red wires and this open circuit voltage should be on the order of 75 to 90 volts. If this is not the case, there will be some element in the power supply circuit preceding this that is defective. It would be necessary to check the diodes in the diode bridge for shorts or open condition. Measure the AC voltage appearing across the diode bridge which would be from the output of the power transformer. If no power appears at this point, determine if the primary of the transformer is receiving line voltage via the contacts from the relay. Be sure to check the fuses that are in series with both legs of the line voltage.

If there is power to the circuit and the proper open circuit voltage is available and the lamp still does not light, it will be necessary to check the relay in the starter circuit. Switch the main power off, reconnect the yellow and green wires to the terminals number 3 and 4 on the starter unit, switch power and lamp switch "on", the relay should close completing a circuit to the primary of the step-up transformer on the starter. If this is the case and voltage does appear at the primary

and the spark gap does not break down and arc as it ought to, then it would be necessary to check the voltage across the secondary of this transformer. Make sure that all the wire connections are tightly screwed down. Disconnect main power, use an ohmmeter to check continuity on the secondary of the step-up transformer. This can be done by putting the probes on the terminals across the spark gap. The spark gap is the cylindrical porcelain unit mounted close to the secondary of the step-up transformer. Also, it would be a good idea to check the continuity of the primary of the transformer. This would best be done by removing the yellow and green wires from terminals number 3 and 4 and then switching the lamp "on". When the relay contacts close, you should get a continuity reading by pressing the probes of the ohmmeter across terminals number 3 and 4 of the starter. If there is no reading, move the probe to the contact on the relay that is connected to one side of the transformer. The other probe would be held on terminal number 4 and a reading should be obtained at that point. If not, the indication is that the transformer is defective.

If there is continuity between terminals 3 and 4 on the starter and also across the spark gap, that would indicate that the transformer is operating properly. Now would be the time to test the voltage on the secondary of the transformer. With the wires connected to 3 and 4, the switch lamp "on" use a high reading on the AC volt meter. A reading of 8 to 10,000 volts will be obtained at the secondary side of the step-up transformer across the spark gap. If a reading is found and the spark gap does not arc, it is possible that the spark gap is defective and should be replaced. This is about the last item that would become defective other than by phy-

sical damage. If a high reading voltmeter is not available, a continuity check on the secondary will do.

A number of by-pass capacitors are used in the circuit to help eliminate stray RF from appearing at the wrong point. It may be necessary to replace the capacitors from time-to-time or at least check to make sure that they are operating properly.

If Lamp Does Not Light, it will be advisable to interchange lamps as a first item in determining why the lamp does not light.

In addition to any of the above procedures, it will be necessary to do the normal routine checking of making sure that all the wires are properly terminated and properly secured so that a good connection exists.

Please note that there are two micro switches in the lamp house which are in series with the line voltage circuit to the step-up transformer. The line voltage will not be completed to the step-up transformer if either of these micro switches or any wire connections between are open. One micro switch is on the door and the other switch is air operated just above the air vent from the cool-in fan below the lamp.

Be also sure to check the lamp switch itself to determine if it is defective or not.

You will notice that the motor drive switch and the blower fan switch both have to be "on" in order to operate the lamp switch. The blower switch being "on" insures that the air will be coming up to the air operated microswitch and the motor drive switch is connected so that the lamp switch receives power only when the motor drive switch is "on".

Check the 5-pin connector plug at the back end of the projector body base. The 7 terminals mounted on the strip at the front of the projector directly in front of the amplifier should be checked for good connections.

Refer to schematics for further help in understanding the complete operation.

EX-3000/5000 SERIES

ELECTRIC SYSTEM DIAGRAM

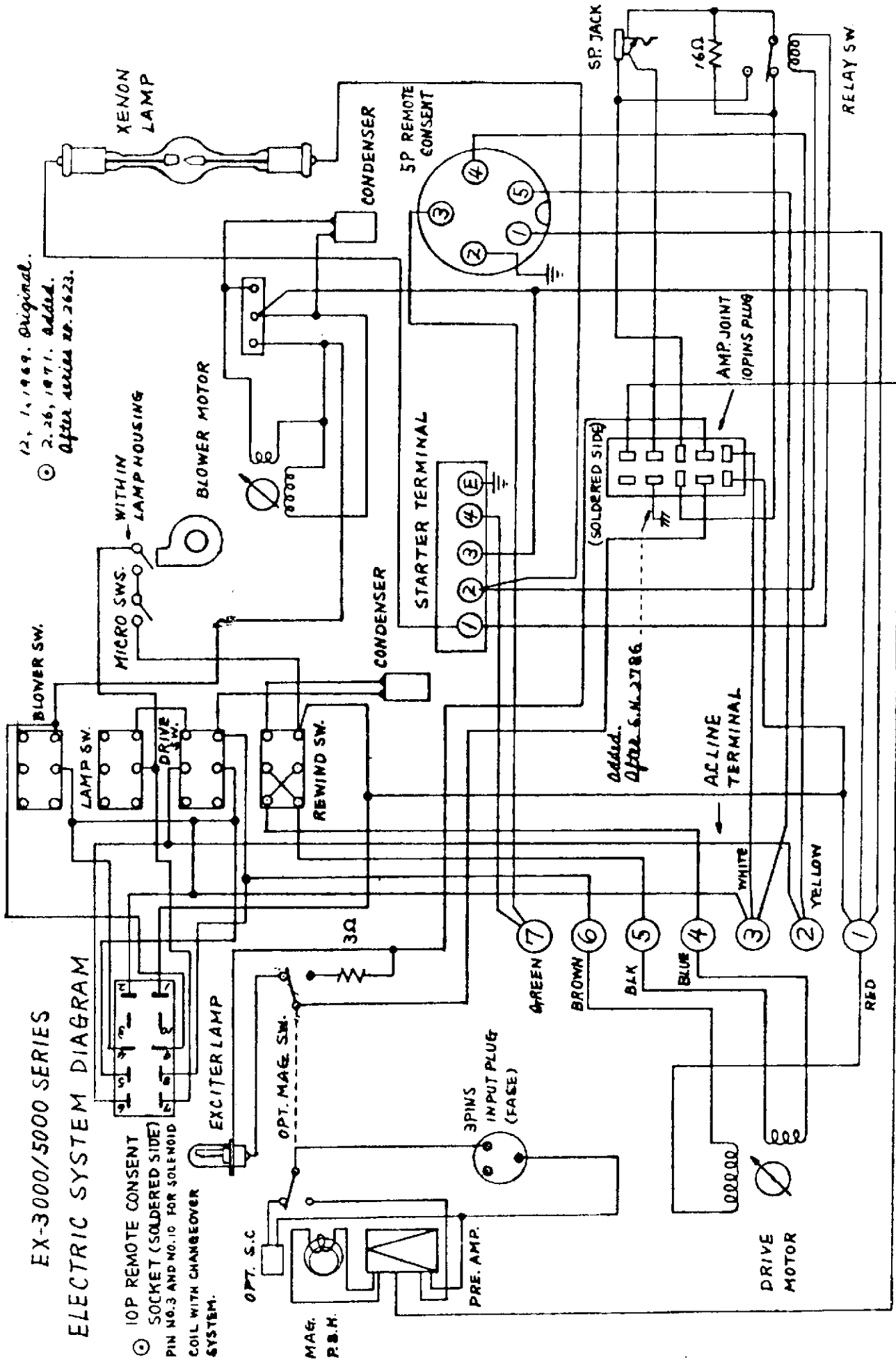

12, 1, 1969. Original.
 © 2, 26, 1971. Added.
 After series no. 2623.

① 10P REMOTE CONSENT SOCKET (SOLDERED SIDE) PIN NO. 3 AND NO. 10 FOR SOLENOID COIL WITH CHANGE-OVER SYSTEM.

Added. After S.N. 2786

ACLINE TERMINAL

DRIVE MOTOR

RELAY SW

No.	ITEM	QTY	Part No.
1	Terminal Strip	1	.X5-62721
2	Capacitor 0.02 mfd 1500WV	1	X5-62271
3	Capacitor 0.005 mfd 1500WV	3	X5-62281
4	Capacitor 1200 pf 15KVW	2	X5-62341
5	Relay	1	X5-62711
6	Spark Gap	1	X5-62331
7	Hi-Volt Transformer	1	X5-62351
8	Tesla Coil	1	X5-62321

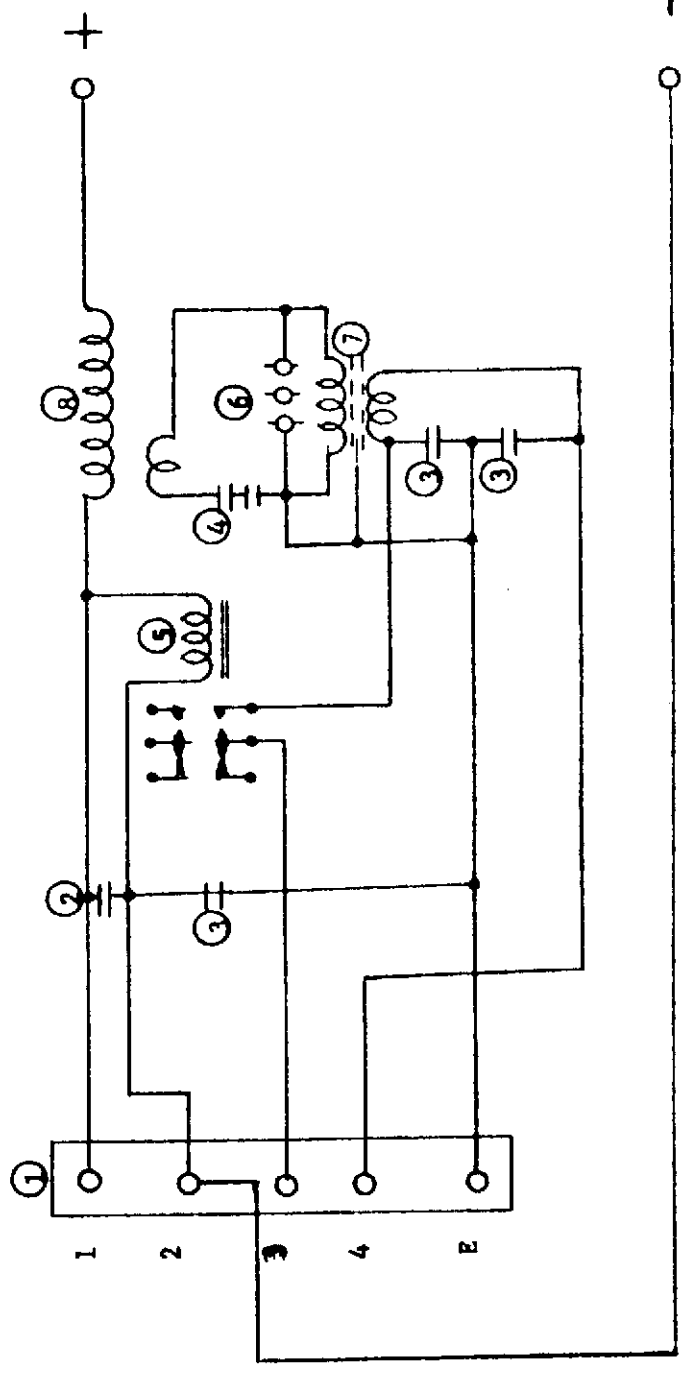

EX-5020 XENON LAMP STARTER

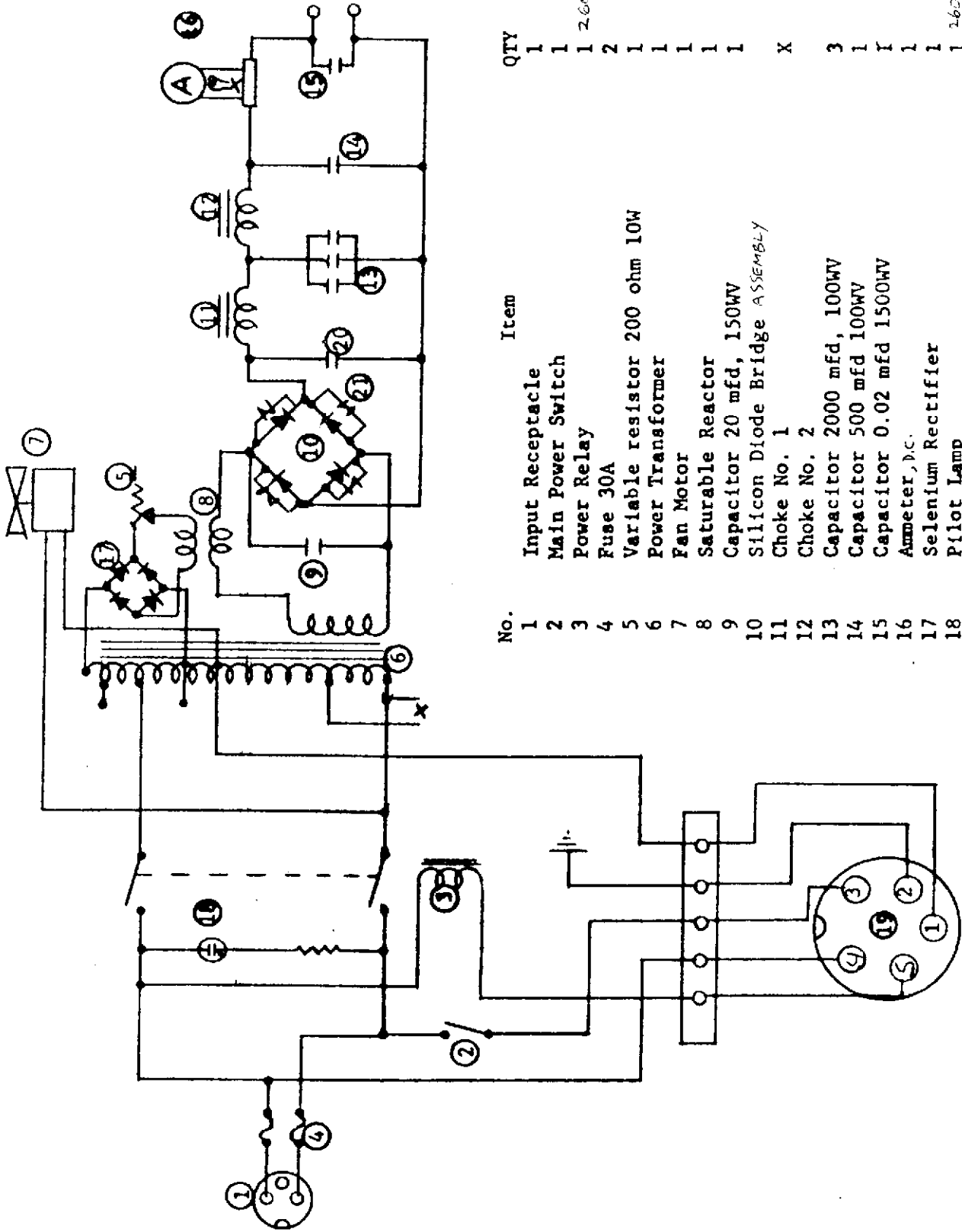

- | No. | Item | QTY | Part No. |
|-----|-----------------------------------|-----|----------|
| 1 | Input Receptacle | 1 | X5-62261 |
| 2 | Main Power Switch | 1 | X5-62021 |
| 3 | Power Relay | 1 | X5-62711 |
| 4 | Fuse 30A | 2 | X5-62011 |
| 5 | Variable resistor 200 ohm 10W | 1 | X5-62251 |
| 6 | Power Transformer | 1 | X5-62051 |
| 7 | Fan Motor | 1 | X5-62381 |
| 8 | Saturable Reactor | 1 | X5-62561 |
| 9 | Capacitor 20 mfd, 150WV | 1 | X5-62541 |
| 10 | Silicon Diode Bridge ASSEMBLY | 1 | X5-62081 |
| 11 | Choke No. 1 | X | X5-62091 |
| 12 | Choke No. 2 | 3 | X5-62571 |
| 13 | Capacitor 2000 mfd, 100WV | 1 | X5-62131 |
| 14 | Capacitor 500 mfd 100WV | 1 | X5-62141 |
| 15 | Capacitor 0.02 mfd 1500WV | 1 | X5-62181 |
| 16 | Ammeter, D.C. | 1 | X5-62161 |
| 17 | Selenium Rectifier | 1 | X5-62531 |
| 18 | Pilot Lamp | 1 | X5-62231 |
| 19 | 5 Pin Cable Connector OUTPUT PLUG | 1 | X5-62521 |
| 20 | Capacitor 200 mfd 150WV | 1 | X5-62541 |
| 21 | Silistor | 4 | X5-62121 |

View from pin end of plug.

ALTERNATING O.K. NEW SINGLE USE 2SD212 OLD DOUBLE USE 2SC647 UPPER LOWER EACH. 7. 1. 1971.

EX-5000 AMPLIFIER CIRCUIT DIAGRAM
EX-5000 SERIES
 12.11.1969

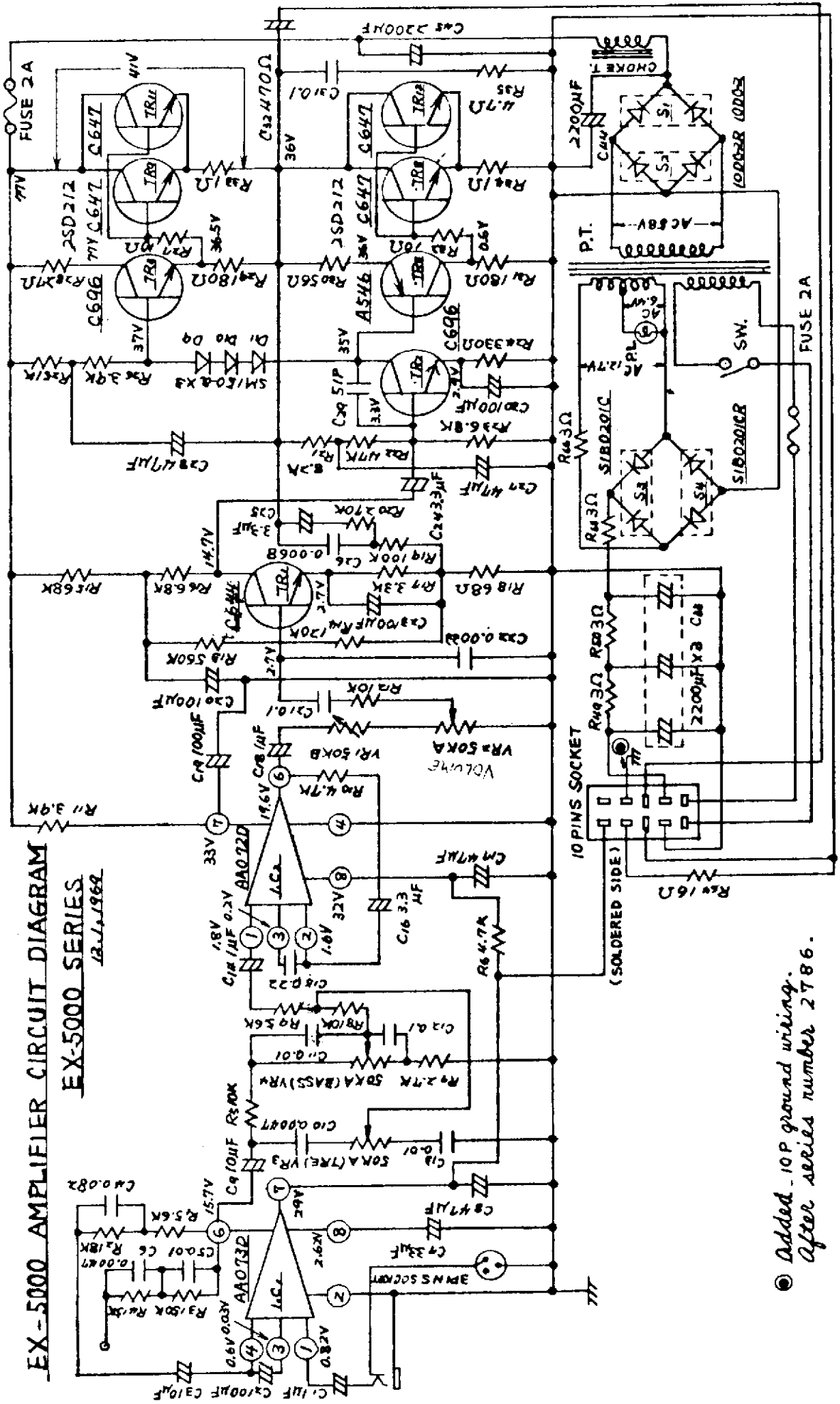

● Added 10P ground wiring.
 After series number 2786.

TRUBLE SHOOTING CHART FOR INTERNATIONAL EX-5020 PROJECTORS

The following information will help the service technician to analyze the problem and determine the actual SOURCE. It is important that the effect be eliminated by curing the actual CAUSE of the problem.

1. MISCELLANEOUS TROUBLES

SYMPTOM	PROBABLE CAUSE	REMEDY
1. No power for motor or lamp.	1. No power at wall outlet. 2. Defective power cord. 3. Defective motor switch	1. Check fuse or multi-breaker of power circuit. 2. Repair or replace 3. Replace
2. Lamp will not light--motor runs.	1. Lamp burned out 2. Lamp switch defective 3. Open micro switches in lamphouse. 4. Rectifier Defective	1. Replace 2. Replace 3. See S.15.1, S.15.2, S.15.3. 4. a. Check open circuit voltage: Should be approx. 75 - 85 V.D.C. b. Check diode bridge for short or open diodes.
3. Film sprockets not turning - motor runs, lamp lights.	1. Stop lever depressed. 2. Motor belt broken. 3. Plate washer ST-11351 loose.	1. Raise lever. 2. Replace 3. Remove camtank as per S.1.6 and tighten screw.
4. Take-up poor or not at all in FORWARD.	1. Broken or stretched take-up arm belt. 2. Take-up arm belt oily. 3. Improper friction at slip clutch. 4. Clutch cam not engaging.	1. Replace 2. Clean 3. See S.2.3 for remedy. 4. Remove pulley X5-12371 and remedy.
5. Rewind poor or not at all	1. Broken rewind belt. 2. Broken or stretched supply arm belt. 3. Supply arm belt oily. 4. Shutter pulley clutch slipping. 5. Motor belt slipping.	1. Replace. 2. Replace. 3. Clean. 4. Clean. See S.1.7, p,q,r. 5. Clean or replace.
6. Film spills from supply reel in FORWARD.	1. Clutch collar X5-15501 binding.	1. Remove, clean and lubricate.

MISCELLANEOUS TROUBLES (CONT.)

SYMPTOM	PROBABLE CAUSE	REMEDY
7. Loop setter rotates continually or erratically.	<ol style="list-style-type: none"> 1. Damaged film. 2. Insufficient spring tension. 3. Loop setter roller defective or too close to gear. 4. Sensing roller in wrong position. 5. Film touching sensing roller because lower loop is too small. 6. Claw protrusion incorrect. 7. Green film. 8. Worm gear on shutter shaft mounted incorrectly, causing variation in claw protrusion. 9. Claw broken. 10. Insufficient lower film shoe pin spring tension. 	<ol style="list-style-type: none"> 1. Repair or replace. 2. Stretch or replace spring, See S.8. 3. Repair or replace as per S.8. 4. Readjust as per S.8. 5. See S.8 to adjust. 6. Adjust as per S.1.5. 7. Treat with film conditioner/lubricant. 8. See S.1.3. 9. Replace. 10. Stretch or replace.
8. Excessive noise in film gate in FORWARD (with good, clean, undamaged film).	<ol style="list-style-type: none"> 1. Upper loop too small. 2. Film touching loop setter. 3. Emulsion build-up on film shoe or gate. 4. Claw loose. 5. Inner guide rail binding. 6. Film shoe binding. 7. Inner guide pressure spring weak. 8. Film shoe bent. 9. Defective claw. 10. Claw position incorrect. 11. Claw protrusion incorrect. 12. Curved spring ST-11161 in camtank broken or weak. 13. Claw stroke incorrect. 14. Outer guide rail not positioned properly. 15. Film shoe lock loose or open. 	<ol style="list-style-type: none"> 1. Increase to proper size. 2. Adjust as per S.3.2. 3. Clean and buff. 4. Tighten. 5. Clean and adjust. See S.9.2. 6. Adjust. See S.9.3. 7. Bend or replace. See S.9.2. 8. Straighten or replace. 9. Replace. See S.1.1. 10. Adjust as per S.1.4. 11. Adjust as per S.1.5. 12. Replace. See S.1.6 and S.1.7. 13. Replace fibre cam ST-11131. See S.1.6, S.1.7. 14. See S.9.1. 15. Bend lock slightly to increase holding tension.
9. Unsteady picture.	<ol style="list-style-type: none"> 1. See previous section dealing with noise in film gate. 	
10. Travel ghost	<ol style="list-style-type: none"> 1. Shutter blade misaligned. 	<ol style="list-style-type: none"> 1. Adjust as per S.1.7.m.

1. MISCELLANEOUS TROUBLES (CONT.)

SYMPTOM	PROBABLE CAUSE	REMEDY
11. Insufficient framing.	<ol style="list-style-type: none"> 1. Claw position incorrect. 2. Framing lever bent or travel restricted. 3. Gate assembly position not correct. 4. Film shoe mislocated vertically. 	<ol style="list-style-type: none"> 1. Adjust as per S.1.4 2. Straighten lever or remove restriction. 3. Entire assembly may be moved up or down. Loosen mounting screws and reposition. 4. See S.9.3
12. Excessive noise when STOP lever depressed.	<ol style="list-style-type: none"> 1. Shutter pulley binding on shaft. 	<ol style="list-style-type: none"> 1. Remove camtank assembly and remove pulley. Clean and lubricate. See S.1.6 and S.1.7.
13. Film transport does not stop when STOP lever depressed.	<ol style="list-style-type: none"> 1. Shutter pulley seized. 2. Stop lever shoulder screws ST-11271 loose. 	<ol style="list-style-type: none"> 1. Remove camtank, clean and lubricate as per S.1.6 and S.1.7. 2. Remove camtnak assembly and tighten. See S.1.6 and S.1.7.
14. Film burns when STOP lever depressed.	<ol style="list-style-type: none"> 1. STOP lever not fully depressed. 	<ol style="list-style-type: none"> 1. Depress FULLY.
15. Uneven screen illumination.	<ol style="list-style-type: none"> 1. Lamp not aligned properly. 2. Foreign object in light path. 3. Defective lamp. 4. Mirror dirty. 	<ol style="list-style-type: none"> 1. Correct. See S.15.13. 2. Remove 3. Replace. 4. Clean See S.15.5
16. Improper focusing.	<ol style="list-style-type: none"> 1. Dirty gate. 2. Film shoe binding. 3. Inner guide rail binding. 4. Lens holder misaligned. 5. Defective lens. 6. Focus knob plastic sleeve defective. 7. Lens binding in lens holder. 8. Film shoe bent. 	<ol style="list-style-type: none"> 1. Clean 2. Adjust. See S.9.3. 3. Clean and adjust. S.9.2. 4. Adjust. See S.9.4. 5. Replace 6. Replace 7. a) Interchange lens from another projector. b) Repair or replace lens holder. 8. Straighten or replace.
17. Light reflections outside of picture area.	<ol style="list-style-type: none"> 1. Film shoe misaligned. 2. Edge of film shoe aperture reflections. 	<ol style="list-style-type: none"> 1. Realign shoe as per S.9.3. 2. Touch up with matte black paint.

MISCELLANEOUS TROUBLES (CONT.)

SYMPTOM	PROBABLE CAUSE	REMEDY
18. Sprocket picking at film.	1. Burr on sprocket teeth.	1. a) Remove and replace sprocket plate in opposite direction. b) Replace sprocket plate.
II. SOUND TROUBLES		
19. No sound	1. Amplifier not switched on. 2. Exciter lamp defective. 3. Fuse blown. 4. Speaker not plugged in. 5. Cable connections in amplifier loose. 6. Speaker defective. 7. Speaker cable defective. 8. On-off switch defective. 9. Amplifier defective. 10. Solar cell defective. 11. Foreign object in optical scanning beam. 12. Magnetic head defective.	1. Switch on. 2. Replace. 3. Replace, if it blows again, check speaker load, must be 8 ohms or more on external speakers. Check output transistors. 4. Plug it in. 5. Plug in or tighten. 6. Replace 7. Repair or replace. 8. Replace 9. Repair or replace. 10. Replace 11. Remove. 12. Replace
20. Low volume.	1. Defective exciter lamp. 2. Dirty optic lens or foreign objects in light beam. 3. Low voltage to exciter lamp 4. Optic lens misaligned. 5. Amplifier defective. 6. Magnetic head dirty. 7. Magnetic head defective. 8. Insufficient tension of magnetic head on film. 9. Defective optic lens. 10. Wrong exciter lamp.	1. Replace 2. Clean 3. Repair amplifier 4. Adjust as per S.10 5. Repair or replace. 6. Clean 7. Replace. 8. Adjust. 9. Replace. See S.10 10. Use BRK with short envelope
21. Loud hum.	1. Exciter lamp cover off or not installed correctly. Light from projection lamp reaches solar cell. 2. Input cable shields loose. 3. Amplifier defective.	1. Install on pins correctly. 2. Repair 3. Repair or replace.
22. Distorted sound.	1. Defective exciter lamp.	1. Replace

cont. on page 5

II. SOUND TROUBLES (CONT.)

SYMPTOM	PROBABLE CAUSE	REMEDY
continued--- 22. Distorted sound	2. Speaker defective 3. Lateral guide roller seized or binding. 4. Sound drum bearings defective. 5. Flywheel off. 6. Flywheel too loose. 7. Magnetic sound over-recorded. 8. Defective amplifier. 9. Optic lens misaligned. 10. Film touching loopsetter. 11. Dirt on sound drum. 12. Sound drum end-play. 13. Defective optic lens. 14. Magnetic head spring tension improper. 15. Wrong exciter lamp.	2. Replace 3. Clean, lubricate and adjust. S.10.3. 4. Replace. See S.11. 5. Install. 6. Tighten 7. Re-record. 8. Repair or replace. 9. Adjust as per S.10. 10. Adjust as per S.3.2. 11. Clean. 12. See S.11. 13. Replace. 14. Adjust. 15. Use BRK with short envelope.
23. Wow and flutter.	1. Lateral guide roller binding. 2. Sound drum bearings defective. 3. Motor drive belts not running true. 4. Lateral guide roller dirty or eccentric. 5. Dirt on No. 2 sprocket drum 6. Flywheel loose.	1. Clean and lubricate. 2. Replace. S.11. 3. Replace belt, clean pulley and be sure belt fits into pulleys properly. 4. Clean or replace. 5. Clean 6. Tighten.