

# FILM-TECH

**THE INFORMATION CONTAINED IN THIS ADOBE ACROBAT PDF FILE IS PROVIDED AT YOUR OWN RISK AND GOOD JUDGMENT.**

**THESE MANUALS ARE DESIGNED TO FACILITATE THE EXCHANGE OF INFORMATION RELATED TO CINEMA PROJECTION AND FILM HANDLING, WITH NO WARRANTIES NOR OBLIGATIONS FROM THE AUTHORS, FOR QUALIFIED FIELD SERVICE ENGINEERS.**

**IF YOU ARE NOT A QUALIFIED TECHNICIAN, PLEASE MAKE NO ADJUSTMENTS TO ANYTHING YOU MAY READ ABOUT IN THESE ADOBE MANUAL DOWNLOADS.**

**[WWW.FILM-TECH.COM](http://WWW.FILM-TECH.COM)**

AUGUST 1965

price \$5.00

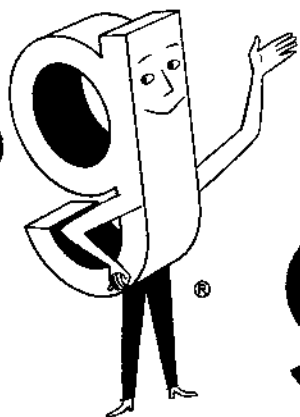
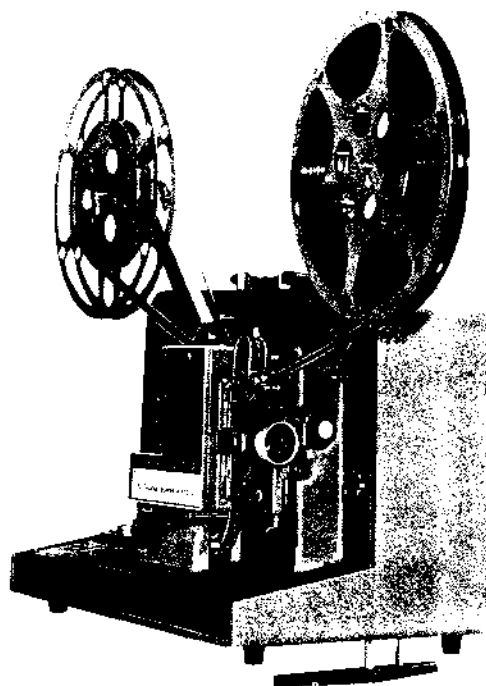

**graflex**®

**AUDIOVISUAL EQUIPMENT  
SERVICE INSTRUCTIONS AND PARTS LIST**

VOLUME 1.3

*Galaxy*® **PROJECTOR**

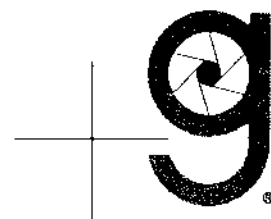

## TABLE OF CONTENTS

	Page
Introduction	iii/iv
<b>SECTION I - THEORY OF OPERATION</b>	
A. Drive System . . . . .	1-1
B. Reverse Operation . . . . .	1-1
C. Sound and Silent Speeds . . . . .	1-1
D. Rewind Operation . . . . .	1-1
E. Projection Optical System . . . . .	1-1
F. Sound Optical System . . . . .	1-2
<b>SECTION II - TROUBLESHOOTING</b>	
A. General . . . . .	2-1
B. Operational Tests . . . . .	2-1
C. Trouble and Remedy Table . . . . .	2-1
<b>SECTION III - SERVICE PROCEDURES</b>	
A. General . . . . .	3-1
B. Special Tools . . . . .	3-1
C. Materials . . . . .	3-5
D. Cleaning . . . . .	3-5
E. Disassembly and Repair . . . . .	3-6
F. Tests and Adjustments . . . . .	3-18
<b>SECTION IV - ILLUSTRATED PARTS LIST</b>	
A. General . . . . .	4-1
B. Projector Coding . . . . .	4-1

## LIST OF ILLUSTRATIONS

Figure	Title	Page
1	Galaxy Projector, Model Super 15 . . . . .	
2	Projector Holding Fixture (Tool No. T-38001-A) . . . . .	iii/iv
3	Roll Pin Extracting Tool (Tool No. T-38000-A) . . . . .	3-1
4	Roll Pin Inserting Tool (Tool No. T-38000-B) . . . . .	3-2
5	Spring Loading Tool (Tool No. T-38001-M) . . . . .	3-2
6	Shuttle Cam Adjusting Tool (Tool No. ST-5884) . . . . .	3-3
7	Claw Arm Pin Protrusion Gauge (Tool No. SK-1226) . . . . .	3-3
8	Claw Arm Adjusting Tool (Tool No. T-38000-H) . . . . .	3-4
9	Sound Drum Locating Plug (Tool No. T-38001-G) . . . . .	3-4
10	Feeler Gauge (Tool No. T-38000-X) . . . . .	3-5
11	Cutaway View of Take-up Clutch Lever . . . . .	3-6
11A	Cam Lubrication Kit Installation . . . . .	3-10
11B	Cutaway View of Sound Head . . . . .	3-11
12	Schematic Diagram, Galaxy Projector Amplifier . . . . .	3-12
12A	Installation of Second Diode . . . . .	3-15
13	Schematic Diagram, Galaxy Models 10 and Deluxe Projectors. . . . .	3-16
14	Schematic Diagram, Galaxy Model 15 Projector . . . . .	3-19
15	Schematic Diagram, Galaxy Model Super 15 Projector . . . . .	3-20
15A	Forward Take-up Tension Measurement . . . . .	3-21
15B	Reverse Take-up Tension Measurement . . . . .	3-22
15C	Gate Tension Measurement . . . . .	3-22
15D	Drawing Extension of Lowest Step. . . . .	3-22
15E	Determining Pull-down (Stroke Position) . . . . .	3-23
15F	Lamp Socket and Optical Path Alignment . . . . .	3-23
15G	Projector Code Location . . . . .	3-25
16	Complete Galaxy Projector . . . . .	4-1
17	Complete Case Assembly . . . . .	4-2
18	Complete Galaxy Projector (Cover Removed). . . . .	4-4
19	Projector Assembly (Sheet 1 of 3). . . . .	4-6
19	Projector Assembly (Sheet 2 of 3). . . . .	4-9
19	Projector Assembly (Sheet 3 of 3). . . . .	4-12
20	Supply Reel Arm Assembly . . . . .	4-16
20A	Take-up Reel Arm Assembly . . . . .	4-20
21	Complete Threading Control Arm. . . . .	4-20
22	Film Feed Shaft Assembly. . . . .	4-22
23	Complete Take-up Clutch Lever . . . . .	4-22
24	Shutter and Cam Assembly . . . . .	4-24
25	Complete Claw Arm . . . . .	4-25
25A	Complete Take-up Sprocket Shoe . . . . .	4-27
25B	Complete Feed Sprocket Shoe . . . . .	4-28
25C	Complete Film Pressure Shoe . . . . .	4-29
25D	Aperture Plate Assembly . . . . .	4-30
25E	Complete Accessory Speaker . . . . .	4-31
25F	Elevation Rod Assembly . . . . .	4-32
25G	Capacitor Assembly . . . . .	4-34
25H	Capacitor and Relay Assembly . . . . .	4-35
26	Complete Amplifier Assembly . . . . .	4-36
27	Complete Component Board. . . . .	4-37
28	Amplifier Chassis Assembly . . . . .	4-38
		4-40

## INTRODUCTION

This manual provides service instructions for the Graflex Galaxy Series of 16 mm sound motion picture projectors, models 10, 15, Super 15, and Deluxe. The instructions and illustrations in this manual pertain to the model Super 15 (Figure 1), and differences between the model Super 15 and the other models are noted where applicable. The manual is divided into four sections - Theory of Operation, Troubleshooting, Service Procedures, and Illustrated Parts List. The theory of operation section contains fundamental explanations of the projector's drive, projection optical, and sound optical systems.

The Trouble and Remedy table of section II will prove an invaluable tool in the quick and positive localization of malfunctions. Section III contains step-by-step service procedures which, when used in conjunction with the illustrated parts list of section IV, provides needed information for efficient equipment servicing.

## Note

Major projector repairs should be undertaken only by skilled service personnel familiar with precision 16 mm projection equipment. Replacement parts should be ordered by number and description from:

GRAFLEX, INC.  
3750 MONROE AVENUE  
ROCHESTER, NEW YORK 14603

The following information is of a general nature and should be kept in mind when using the service instruction manual:

The No. DC 44 lubricant (manufactured by Dow Chemical Co., Midland, Mich.) is available in several viscosities. Use the light variety wherever No. DC 44 lubricant is specified.

The Deluxe model has been discontinued, and two new models (Deluxe 10 and Deluxe 15) have been added to the Galaxy Series. The Deluxe 10 and Deluxe 15 models are mechanically the same as the 10 and 15 models, respectively, with the exception of the cases and nameplates.

The threading control lever is referred to as the Graflever in the operator's manual accompanying the projector and on the Operating Instructions card supplied with and mounted on the projector.

When replacing screws (especially self-tapping screws) which are likely to work loose, secure the screws in place with Glyptal resin (General Electric Co., Schenectady, N.Y.).

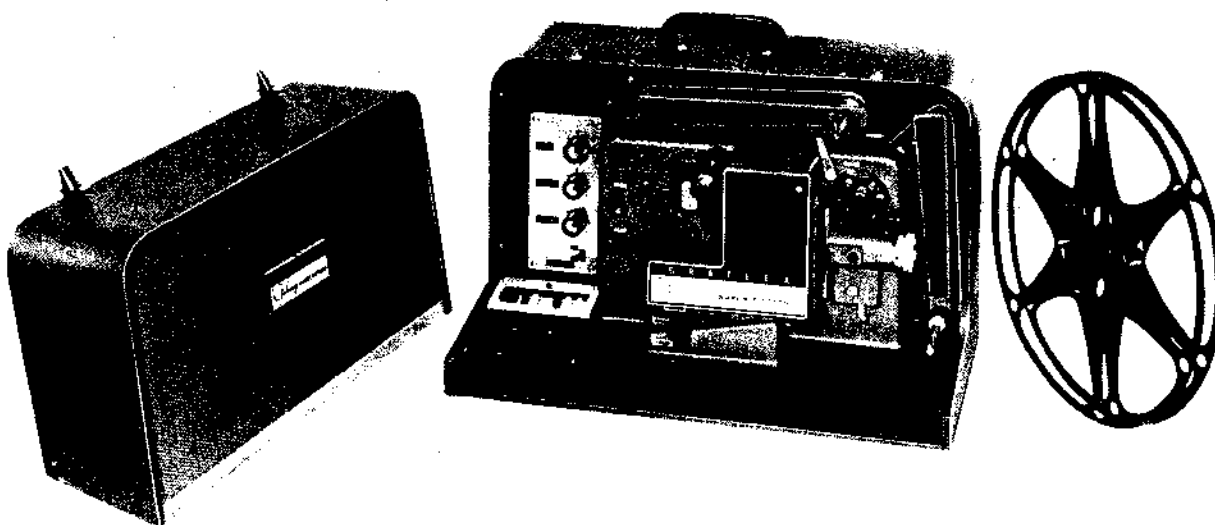

Figure 1. Galaxy Projector, Model Super 15

## SECTION I

### THEORY OF OPERATION

#### A. DRIVE SYSTEM

The drive system employs a 1/40-hp induction motor to rotate the gear mechanisms and associated sprocket assemblies which drive the film through the projector. Depressing the RUN pushbutton energizes the drive motor, which rotates the main drive shaft by means of a belt and pulley arrangement. The drive shaft has identical worm gear assemblies mounted on each end which mesh with and, in turn, rotate the gears and associated sprockets of the feed takeup mechanisms. Pulleys mounted on the shafts of these mechanisms are used in conjunction with reel belts to provide rotational power for the feed and takeup reels. The film, upon being fed from the supply reel, is engaged by the feed sprocket and enters a channel formed by the aperture plate and pressure shoe assemblies. The pressure shoe assembly is spring loaded and presses the film gently against the aperture plate assembly, providing positive frame-to-frame positioning of the film. The film emerges from the channel and feeds onto the sound drum, located behind the sound head loading slot. The sound drum accurately positions the sound track of the film and stabilizes its rate of travel. The film is drawn through the sound head by the takeup sprocket, which feeds the film onto the takeup reel.

#### B. REVERSE OPERATION

The drive system of models 15 and Super 15 may be operated in reverse, enabling the operator to reproject any portion of the film. The reverse operation is incorporated in the threading control system, which has a cam-operated, motor-control switch. Placing the threading control lever in the REVERSE position rotates a plate-type cam by means of the control shaft, actuating the switch and reversing one winding of the drive motor; this results in reverse rotation of the motor and the projector mechanism.

#### C. SOUND AND SILENT SPEEDS

All Galaxy Series projectors incorporate a speed change mechanism to provide silent or sound projector drive speeds (18 or 24 frames per second, respectively). The speed change mechanism comprises a two-position step pulley, a return spring, a belt shift guide, a speed change cam, and a SOUND/SILENT control lever. Placing the SOUND/SILENT lever in the SILENT position rotates the speed change cam against the step pulley, moving it forward on the main drive shaft. The belt shift guide prevents the drive belt from moving with the pulley; therefore, the belt tracks onto the larger step of the pulley, resulting in a change of drive shaft rotation to the slower speed.

Returning the SOUND/SILENT lever to the SOUND position rotates the cam away from the pulley. As the result, the return spring moves the pulley back to its original position on the drive shaft, the drive belt is guided back to the smaller step of the pulley, and the drive shaft rotation returns to the higher speed.

#### Note

Shifting of the drive belt is facilitated by rotation of the step pulley; therefore, the SOUND/SILENT lever may be moved only when the drive system is in operation.

#### D. REWIND OPERATION

Graflex Galaxy Series projectors are equipped with a fast, positive, rewind system. Moving the REWIND lever to its REWIND position engages the REWIND latch with the carrier of the feed shaft mechanism, stopping it and causing three, equally spaced, planetary gears mounted to the face of the carrier to be driven by the internal teeth of the drive gear. The three planetary gears, in turn, drive the supply reel drive pulley in reverse at increased speed, resulting in reverse rotation of the supply (rewind) reel. The rewind latch is connected by the latch link to the pawl in the takeup ditch lever assembly. Therefore, movement of the REWIND lever to its REWIND position causes the pawl to engage the inner ratchet of the takeup clutch lever assembly, stopping rotation of the drive hub. Further travel of the pawl then engages the outer ratchet, rotating it relative to the inner ratchet. This action unwinds the clutch spring, leaving the pulley (and, in turn, the takeup reel) free to rotate for rewinding of the film. When the motor is stopped, the system tension is relieved, releasing the latch link to restore normal forward operation.

#### E. PROJECTION OPTICAL SYSTEM

The projection optical system consists of a 250-watt, 21-1/2-volt projection lamp, a claw assembly, a cam and shutter assembly, a still shutter (Super 15 only), an aperture plate, and an objective lens. The projection lamp, located behind the film, provides the light beam for projecting the film image. A dichroic reflector built into the lamp reflects visible light forward through the optical system but allows the heat-producing infrared rays to pass through it to the rear of the projector. Depressing the LAMP-NORM or HI pushbuttons selects one of two levels of lamp brilliancy. With the LAMP-NORM pushbutton depressed, 17-1/2 volts is supplied to the lamp. Depressing the LAMP-HI pushbutton delivers 21-1/2 volts to the lamp, resulting in a higher than normal lamp brilliancy. The func-

## Section I Theory of Operation

tion of the rotary shutter, which is mounted on and rotates with the main drive shaft, is to cut off the light during periods of film movement and to prevent flicker or blurring of the projected image.

### Note

Galaxy model Super 15 Projectors are provided with a 2-3 blade automatic shutter and a still shutter. Models 10, 15, and Deluxe have the standard, 3-blade shutter.

The claw assembly is the mechanism used to intermittently stop and move the film at the aperture plate. The claw arm rides on a cam attached to the rotary shutter, which moves the arm through a rectangular pattern. Pins mounted at the end of the arm engage, stop, move, and release each frame of the film. Approximately 0.0064 second of movement is followed by 0.047 second with the picture in place.

The automatic shutter is composed of three blades of equal size; one blade is fixed and the other two are movable (controlled by a spring-loaded actuator plate). The fixed blade cuts off the light from the picture while it is in motion, while the other blades interrupt the light additionally at regular intervals in between. At sound speed (24 frames per second), the movable blades of the shutter move into coincidence due to centrifugal force on the actuator plate. When the projector is operated at silent speed (18 frames per second), the tension of the springs overcomes the decreased centrifugal force caused by a corresponding decrease in rotational speed, and the blades are pulled back to form the three-blade configuration. When the projector is operated at sound speed under certain conditions, the intensity of light projected on the screen may be too great, even with the projection lamp operating at the "normal" level of brilliancy. To further reduce the light intensity, the shutter is equipped with a latch which, when pressed inward, locks the inner and outer shutter blades to provide a fixed three-blade configuration.

Galaxy model Super 15 projectors are provided with a still shutter to protect the film from the heat of the projection lamp when a single frame is projected as a still picture. The still shutter is composed of an optical filter, a silicone clutch hub, and a return spring. Rotation of the main shaft produces a viscous drag which causes the shutter to move upward (or downward) out of the optical path. The still shutter link limits the shutter movement, leaving the shaft free to turn. Depressing the STILL push-button interrupts the power supply circuit to the drive motor and stops the drive system. The still shutter is pulled into the optical path by the return spring.

### F. SOUND OPTICAL SYSTEM

The sound optical system converts variations in the sound track of the film into electrical variations which are amplified by the amplifier and converted to sound waves by the speaker system. The system is composed of an exciter lamp, a sound optics cartridge, a phototransistor unit, an amplifier, and a speaker network. As the film is driven through the projector, the sound track portion of the film passes between the sound optics cartridge and the phototransistor unit. The sound optics cartridge focuses the beam of light from the exciter lamp through the sound track onto the phototransistor unit. Variations in the sound track cause corresponding variances in the amount of light transmitted to the phototransistor unit. Corresponding variations in electron flow through the phototransistor are reflected as voltage changes and amplified by the amplifier. The output of the amplifier is converted into sound waves by the speaker network.

### Note

The Galaxy model Super 15 projector is equipped with two speakers (an 8-inch woofer capacitor-coupled to a 4-inch tweeter), providing a higher quality of sound reproduction.

SECTION II  
TROUBLESHOOTING

A. GENERAL

Perform the operational tests outlined in paragraph B, using a 400-foot reel of 16mm test film of known picture and sound qualities. If any malfunctions or irregularities are noted during testing, refer to the Trouble and Remedy table of paragraph C to localize the trouble, then refer to the applicable service procedures.

B. OPERATIONAL TESTS

1. Connect power cord to projector and power source, and depress RUN pushbutton. Ensure that the drive motor is running by observing the reel belt and sprocket rotation. Listen for unusual rattles, squeaks, or noises. Depress LAMP-NORM pushbutton and observe screen brilliance and distribution of light on screen. Depress LAMP-HI pushbutton; screen brilliance should be greatly increased. On Galaxy model Super 15 projector (only), depress STILL pushbutton; sprockets and reel belts should stop rotating. Depress OFF and LAMP-OFF pushbuttons.

2. Place AMPLIFIER-ON/OFF switch in ON position. Pilot lamp and threading lamp should glow. Rotate threading control lever to THREAD position. Thread projector with 400 feet of test film, ensuring that reels, follower, and rollers are functioning properly. Rotate threading control lever to FORWARD position and depress RUN pushbutton. Observe film passage through film path, checking feed and takeup tension. Inspect moving film for film step, weaving of film in soundhead slot, or other abnormal indications.

3. Depress LAMP-NORM pushbutton and focus picture on screen. Check sharpness of picture,

observing for double images or trailer ghost. Adjust framing control so that upper or lower frame line is visible on screen; check for picture jump, side shake, or weave.

4. Insert speaker plug into SPKR jack and adjust AMPLIFIER-VOLUME control for satisfactory listening level. Check for sound crispness, wow, and flutter. Rotate AMPLIFIER-BASS and TONE controls and listen for noise or distortion. Rotate AMPLIFIER-VOLUME control to a point where distortion is barely audible, and listen for speaker rattle or buzzing of speaker case hardware. Adjust AMPLIFIER-VOLUME control for normal level of sound.

5. Rotate SOUND/SILENT lever to SILENT position while observing sprocket and reel rotation. Speed of sprocket and reel rotation should be reduced slightly. Return SOUND/SILENT lever to SOUND position.

6. Rotate AMPLIFIER-VOLUME control fully counterclockwise and threading control lever to REVERSE position. Check film passage through film path, observing sprocket and reel operation. Rotate threading control lever to FORWARD position and observe takeup at end of reel. When all film has passed through projector, depress OFF pushbutton and attach end of film to supply reel for rewind operation. Hold REWIND lever to right and depress RUN pushbutton. Check that REWIND lever remains in position after mechanism has engaged.

C. TROUBLE AND REMEDY TABLE

The purpose of the following table is to list the most commonly encountered difficulties. Generally, troubles due to operational errors will not be listed, as it is assumed that the serviceman is thoroughly familiar with troubles of this type.

TROUBLE AND REMEDY TABLE

TROUBLE	PROBABLE CAUSE	REMEDY
1. <u>FILM HANDLING TROUBLES</u> (Test film must be in good condition)		
a. Take-up reel does not revolve	Take-up belt damaged	Replace belt
	Take-up pulley loose on take-up shaft	Replace pulley assembly (refer to Section III)
	Take-up shaft bent	Replace pulley assembly



TRUBLE AND REMEDY TABLE (CONT)

TROUBLE	PROBABLE CAUSE	REMEDY
a. Take-up reel does not revolve (continued)	Take-up spindle bent	Replace spindle
	Take-up clutch latch link not properly adjusted	Adjust (refer to Section III)
b. Too little or no take-up with light loads (may be erratic)	Brake in take-up arm produces too much torque	Adjust
	Too little bias force produced by spring (137, Figure 19)	Remove coils from spring to adjust for proper tension
	Lip of lever assembly casting (20, Figure 23) may be cracked or broken at point of engagement with roll pin or reel arm shaft	Replace lever assembly
	Felt clutch of hub assembly (4, Figure 23) dry (may be erratic failure)	Lubricate with DC 44 grease
	End play on shaft of lever assembly (20, Figure 23) less than 0.001 inch, causing hub assembly (4, Figure 23) to bind	Adjust for end play, of 0.001 to 0.004 inch
	Shaft of lever assembly (2, Figure 23) may not be square with casting boss	Replace lever assembly
	Groove in pulley assembly (12, Figure 23) worn smooth	Refer to step c below
c. Too much take-up drive, causing belt squeal, broken film or torn sprocket holes	Felt clutch of hub assembly (4, Figure 23) worn by scored gear assembly (139, Figure 19) as a result of operating without proper lubrication of felt	Replace hub assembly (4, Figure 23) and gear assembly (139, Figure 19). Thoroughly lubricate felt with DC 44 grease. May also require replacement of pulley assembly (12, Figure 23)
d. Rewind stall part way through reel	Clutch spring (17, Figure 23) fails to release pulley assembly (12, Figure 23) due to pawl spring not engaging outer ratchet (18, Figure 23)	Adjust end of spring wire on pawl assembly to be visually square or leaning slightly toward outer ratchet (18, Figure 23)
	Latch link (2, Figure 23) hits motor boss, preventing engagement of pawl assembly (10, Figure 23) with inner ratchet (16, Figure 23)	Adjust latch link to clear motor boss and engage pawl assembly
	Latch link may be too short and spring wire on pawl assembly (10, Figure 23) may stop outer ratchet (18, Figure 23), causing forward take-up failure	Adjust latch link

TROUBLE AND REMEDY TABLE (CONT)

TROUBLE	PROBABLE CAUSE	REMEDY
d. Rewind stall part way through reel (cont)	Rewind latch (1, Figure 23) may be restricted in its travel, picking up only the tip of the carrier spur (11, Figure 22) of the feed shaft mechanism and thus will not stay in rewind engagement	Adjust latch link
	Pawl (10, Figure 23) tab may bind on pulley rim (12, Figure 23), preventing release of clutch spring (17, Figure 23) by inner ratchet (16, Figure 23)	Adjust pawl tab
	Pawl does not fully engage ratchet (16, Figure 22)	Adjust latch link
	End of guide (7, Figure 23) catches reel belt joint	Bend end of guide back slightly to clear belt
e. Upper loop not maintained	Feed arm spindle bent	Replace spindle (refer to Section III)
	Feed sprocket loose on shaft	Tighten feed sprocket set-screw
	Defective part in feed shaft mechanism assembly	Repair (refer to Section III)
	Feed sprocket teeth damaged or missing	Replace sprocket
	Claw protrusion not set correctly	Reset to 0.045 inch
	Pulldown not properly adjusted	Reset to 0.3015 inch
f. Lower loop not maintained	Pressure shoe not seating properly	Adjust pressure shoe (refer to Section III)
	Pressure shoe intermittently worn	Repair shoe (refer to Section III)
	Excessive gate pressure applied to "green" film	Reduce gate pressure (refer to Section III)
	Pulldown not properly set	Reset to 0.3015 inch
g. Film scratch or film slap	Worn or dirty part in film path	Locate source of trouble with small loop of film threaded as follows: (1) Feed sprocket, (2) Film channel, (3) Soundhead, and (4) Take-up sprocket; Clean or replace defective part
h. Clicking noise (film picking)	Sprocket teeth damaged	Replace sprocket

TRUBLE AND REMEDY TABLE (CONT)

TROUBLE	PROBABLE CAUSE	REMEDY
i. Too much drive with light load	Too much tension on bias spring (137, Figure 19)	Relocate spring on ear of retaining ring (137A, Figure 19) closer to take-up clutch lever or stretch spring to decrease tension
	Roll pin (4, Figure 19) may bind on lever assembly casting lip (20, Figure 23)	File lip to relieve
	Take-up arm stop pin binds in reel arm hole	File to relieve
j. Spills film in reverse or rewind	Inner ratchet (16, Figure 23) binding on pulley assembly (12, Figure 23)	Reposition spring and adjust for end play of 0.001 to 0.004 inch
	Excessive end play on shaft of lever assembly (20, Figure 23) allows spring (17, Figure 23) to be trapped	
k. Rewind failure	Excessive end play of pawl assembly (10, Figure 23) may allow tab of pawl to bind on rim of pulley assembly (12, Figure 23)	Adjust for end play of 0.001 to 0.004 inch. Pawl assembly should be held with 2 retaining rings (11, Figure 23)
l. Loose take-up or rewind	Warped or stretched film edge	Replace film
2. <u>PICTURE TROUBLES</u> (Test film must be in good condition)		
a. Picture jump (with green film)	Excessive gate pressure	Reduce gate pressure (refer to Section III)
b. Picture jump (with used film)	Insufficient gate pressure	Increase gate pressure (refer to Section III)
	Aperture plate or pressure shoe worn or bent	Replace plate or shoe (refer to Section III)
c. Sidesway (weave)	Side tension spring worn or bent	Replace spring (refer to Section III)
d. In and out of focus (right hand side only)	Side tension spring worn or bent	Replace spring (refer to Section III)
	Uneven gate pressure	Adjust film pressure shoe
e. In and out of focus (random)	Pressure shoe sticks	Adjust shoe (refer to Section III)
	Aperture plate or pressure shoe worn	Replace plate or shoe (refer to Section III)
	Loose element in projection lens	Tighten element
f. Poor focus and halo	Projection lens dirty	Clean lens (refer to Section III)

TROUBLE AND REMEDY TABLE (CONT)

TROUBLE	PROBABLE CAUSE	REMEDY
<b>3. SOUND TROUBLES</b>		
a. No sound, amplifier tubes do not light	Circuit breaker open	Reset with RESET FUSE pushbutton
	Defective AMPLIFIER ON/OFF switch (S-1)	Replace switch (see Figure 13, 14, or 15 and Figure 18)
	Loose connection	Locate trouble and repair
b. No sound, tubes light, exciter lamp does not light, hiss from speaker	Defective exciter lamp Defective diode	Replace lamp Test and replace as required
c. No sound, no hiss from speaker, exciter lamp does not light	Connected to d-c power source	Use a-c power only
d. No sound, no hiss from speaker, exciter lamp lights	Speaker cable broken Defective tubes	Repair cable Test and replace defective tube
	Other amplifier troubles	Remove amplifier and service (refer to Section III)
e. Low volume	Insufficient exciter lamp voltage	Adjust to 3.9 volts
f. Low volume and/or excessive hum	Defective output tubes	Test and replace defective tubes
	Defective filter condenser	Replace filter condenser (see figure 28)
	Low line voltage	Check line voltage
g. Insufficient volume, weak highs	Sound optical system dirty	Clean system (refer to Section III)
h. Short exciter lamp life	Excessive exciter lamp voltage	Adjust to 3.9 volts
i. Microphonics	Defective exciter lamp or tubes	Isolate trouble and replace defective part
j. Heavy continuous shock	Wiring shorted to housing	Repair wiring
k. Pitch of sound nearly correct, no highs	Sound optical system dirty or out of focus	Clean system and refocus

TRUBLE AND REMEDY TABLE (CONT)

TROUBLE	PROBABLE CAUSE	REMEDY
1. Pitch of sound low and distorted	Soundhead misaligned	Realign soundhead (refer to Section III)
	Sound optical system dirty or out of focus	Clean and focus system (refer to Section III)
	Insufficient line voltage	Check line voltage
m. Pitch of sound changes rapidly (flutter)	Sound drum bearings dirty or worn	Clean or replace soundhead (refer to Section III)
	Film damper inoperative	Repair
<b>4. MISCELLANEOUS TROUBLES</b>		
a. Excessive vibration	Worn or broken gear Main drive shaft bent	Replace gear Replace shaft (refer to Section III)
b. Slow running in both sound and silent drive speeds	Stretched or worn main drive belt	Replace belt
	Low line voltage	Operate projector from correct line voltage
	Cam lubricator dry	Oil lubricator wick

SECTION III  
SERVICE PROCEDURES

A. GENERAL

This section provides instructions for disassembly, cleaning, servicing, reassembly, and adjustment of the projector. Refer to the applicable exploded views in Section IV when performing disassembly and reassembly procedures.

B. SPECIAL TOOLS

Servicing of Galaxy projectors will be facilitated by use of the tools described in the following paragraphs.

NOTE

Some tools may be constructed according to the illustrations provided. Each tool

Note (cont)

identified by a Graflex part number may be obtained by ordering individually.

1. Projector Holding Fixture (Tool No. T-3800-1-A)

This fixture, constructed of wood, is used to support the projector when removed from its case. (See Figure 2.)

2. Roll Pin Extracting Tool (Tool No. T-38000-B)

This is a standard No. 181-8 grip hand tool (Sargent and Co., Chicago, Ill.), modified for extraction of roll pins in the projector. (See Figure 3.) A 1-inch

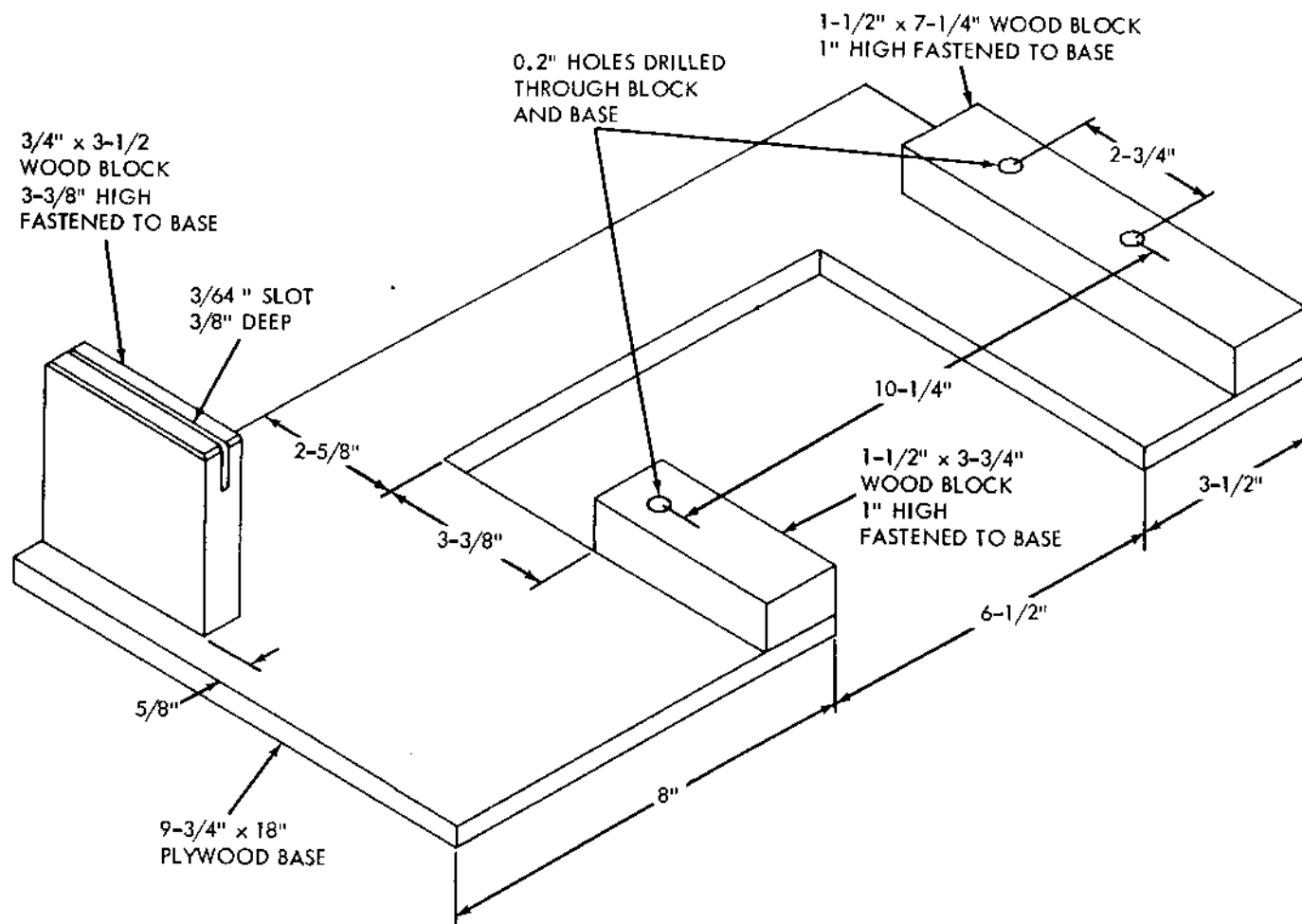

Figure 2. Projector Holding Fixture (Tool No. T-38001-A)

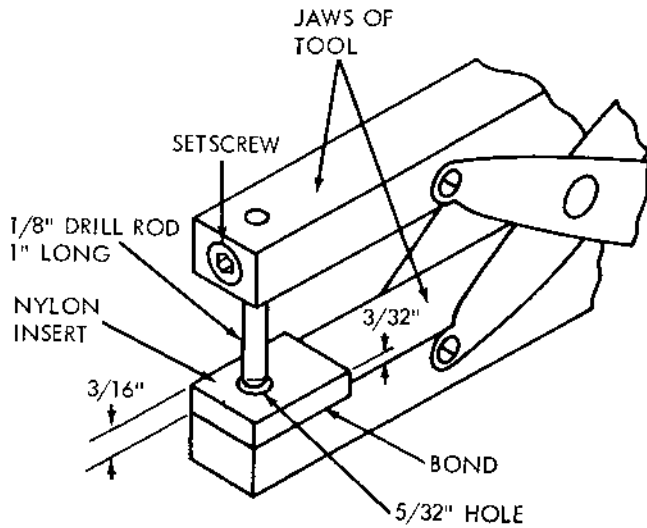

Figure 3. Roll Pin Extracting Tool  
(Tool No. T-38000-B)

A piece of 1/8-inch drill rod is secured to one of the jaws of the tool by a setscrew. A hole in the other jaw provides clearance for the extracted pin.

3. Roll Pin Inserting Tool (Tool No. T-38000-A)

This is a standard No. 181-8 grip hand tool (Sargent and Co., Chicago, Ill.), modified for insertion of roll pins in the projector. (See Figure 4.) A piece of drill rod, 13/32-inch long x 3/16-inch diameter is secured to one of the jaws of the tool. A 1/8-inch hole in the other jaw provides clearance for the pin.

4. Spring Loading Tool (Tool No. T-38001-M)

This tool, shown in Figure 5, is used to pre-load the reel tension arm spring.

5. Shuttle Cam Adjusting Tool (Tool No. St-5884)

Two of these tools (see Figure 6) are required to adjust pull-down and side clearance.

6. Claw Arm Pin Protrusion Gauge (Tool No. G14-38000)

This gauge is fabricated from tool steel in accordance with Figure 7. (Nominal pin protrusion is 0.040 inch.)

7. Claw Arm Adjusting Tool (Tool No. T-38000-H)

This tool is no longer required for service procedures.

8. Sound Drum Locating Plug (Tool No. T-38001-G)

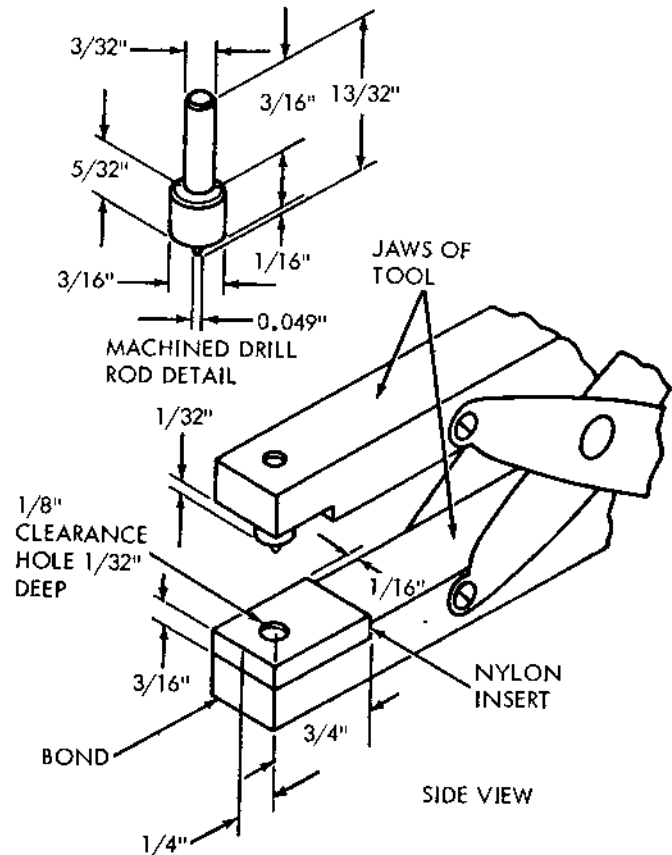

Figure 4. Roll Pin Inserting Tool  
(Tool No. T-38000-B)

This plug is fabricated in accordance with Figure 9. (The plug is inserted into the projector in place of the sound head to determine its lateral position.)

9. Feeler Gauge (Tool No. T-38000-Y)

This tool, shown in Figure 10, is a 0.004-inch thick piece of steel used to set the end play of the take-up clutch lever.

10. Stroke Setting Gauge (Tool No. ST-5880)

This gauge is a piece of stainless steel with perforations exactly like double perforated 16 mm motion picture film. A step wedge in the gauge represents the tolerances acceptable in the pull-down adjustment. The Galaxy Projector functions as an optical comparator when this tool is used.

11. Film Tension Gauge (Tool No. T-38000-S)

This gauge, calibrated in grams and ounces, is a modified scale used to measure forward and reverse take-up tension, gate tension, supply reel brake tension, and net reverse drive force. A roller is attached to the gauge to provide a means of attaching the film.

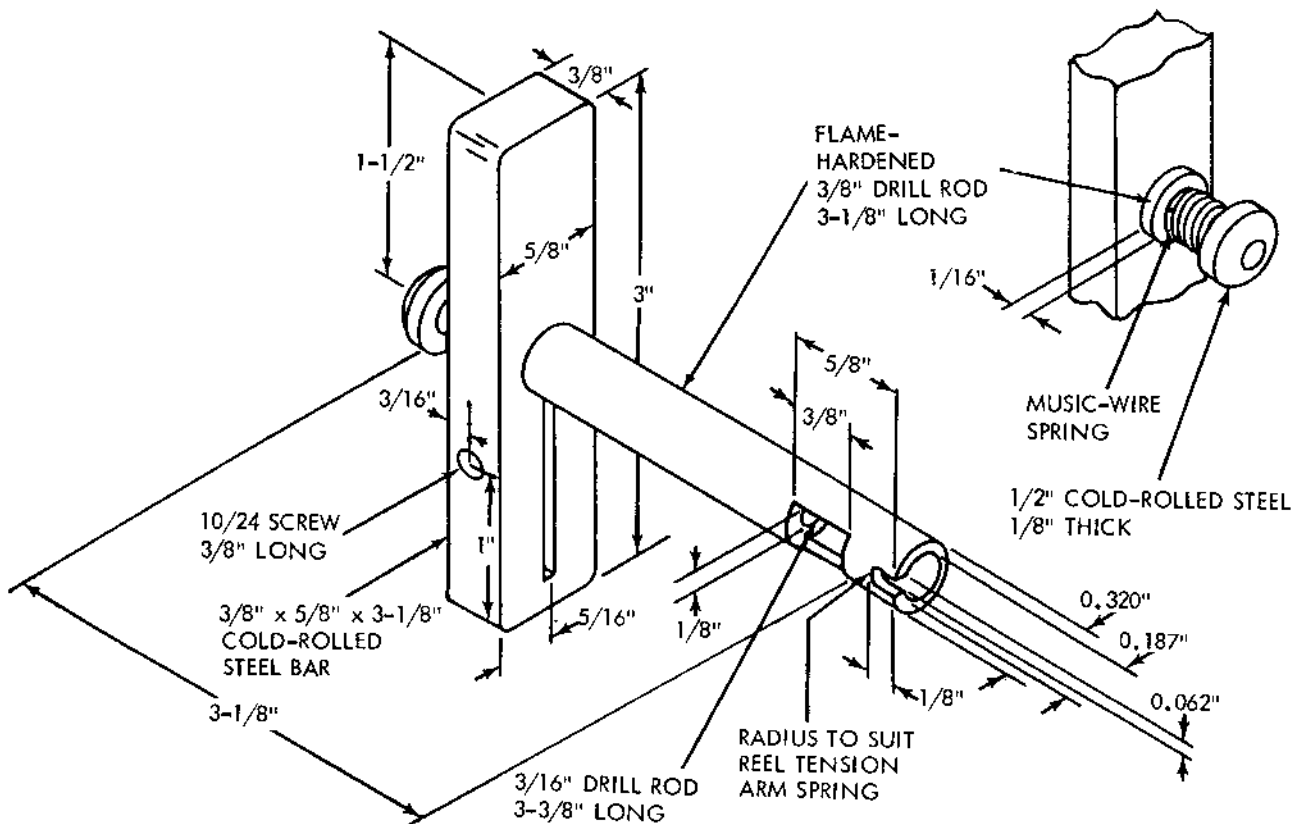

Figure 5. Spring Loading Tool (Tool No. T-38001-M)

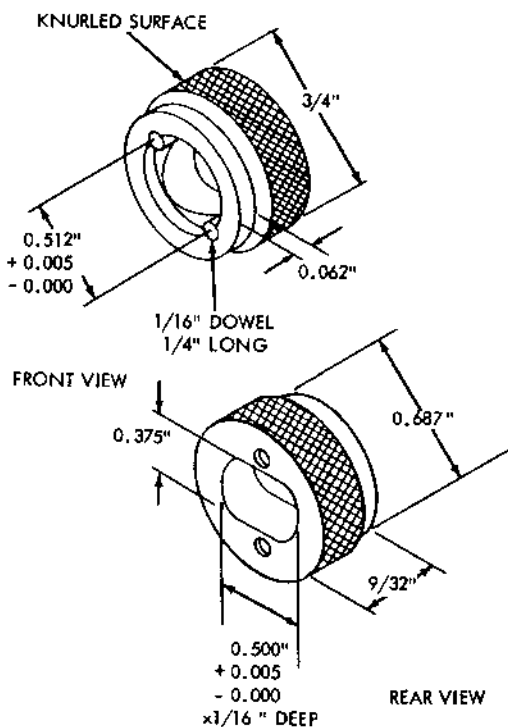

Figure 6. Shuttle Cam Adjusting Tool  
(Tool No. ST-5884)

12. Lamp and Optical Path Aligning Tool (Tool No. G3-38000)

This tool is used to align the projection lamp socket for even illumination of the screen by the projection lamp. It is also used to align the aperture plate with respect to the optical path.

13. Vertical Cam Wrench Set (Tool No. T-38000-W)

Two wrenches of this type are required to adjust the tension of the claw arm return spring.

14. Waldes Tru-Arc Applicator No. 52 (Tool No. T-38000-U)

This tool is used to remove and assemble small retaining rings.

15. Waldes Tru-Arc Applicator No. 54 (Tool No. T-38000-V)

This tool is used to remove and assemble large retaining rings.

16. Waldes Tru-Arc Applicator No. CR-31 (Tool No. T-38000-X)

This tool is used to remove and assemble "C" rings.



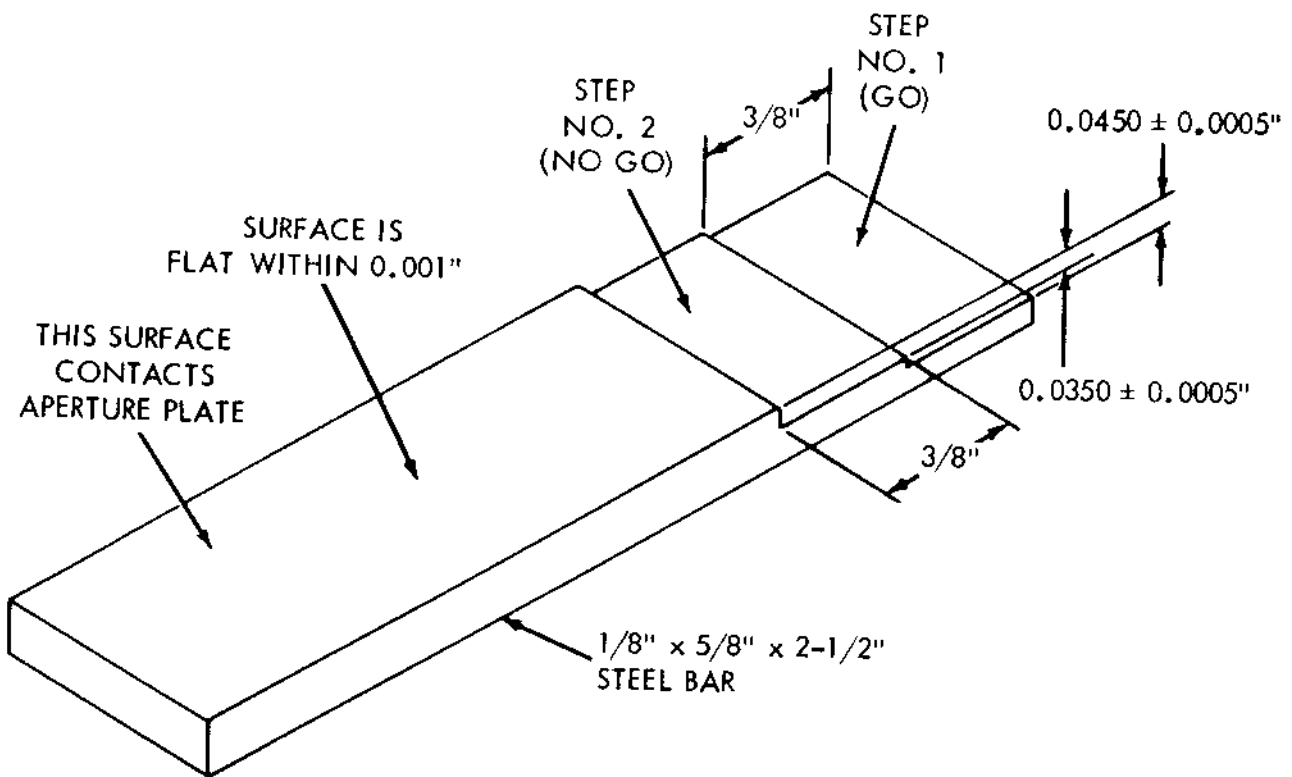

Figure 7. Claw Arm Protrusion Gauge (Tool No. G14-38000)

DO NOT USE.

Figure 8. Claw Arm Adjusting Tool (Tool No. T-38000-H)

This tool is no longer required for service procedures.

C. MATERIALS

The materials required to service Galaxy projectors are listed in the table below. The stock numbers of materials obtainable from Graflex are included. (Numbers for test films are those of the Society of Motion Picture and Television Engineers, 55 West 42nd St., New York 36, New York; these films are NOT procurable from Graflex.)

D. CLEANING

1. External Parts

a. Case - Remove dust from outside of case (1, Figure 16) with compressed air or fine brush. (Exterior surface of case may be waxed.)

b. Film Path - Pull lens forward and remove complete film pressure shoe (72A, Figure 19); clean its parts with cloth dampened with methyl alcohol or clean water. Clean aperture plate assembly (80A) and remove deposits of dirt and emulsion from notches of side tension spring (1, Figure 25D)

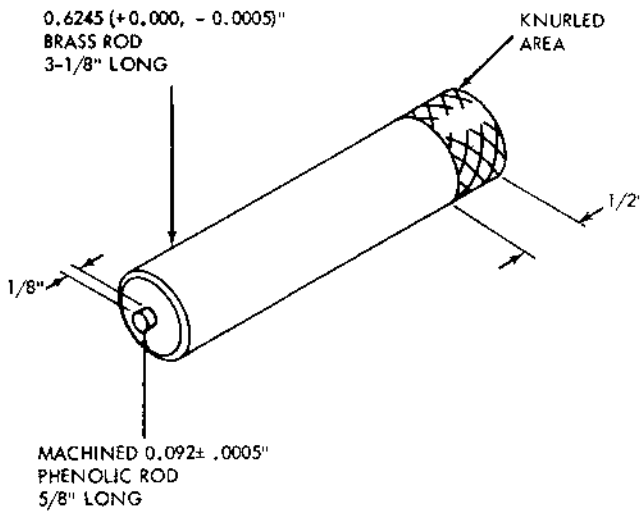

Figure 9. Sound Drum Locating Plug  
(Tool No. T-38001-G)

TABLE OF SERVICING MATERIALS

STOCK NO.	GRAFLEX STOCK PACKAGE	DESCRIPTION
36-20-342	2 oz	DC 44 light consistency silicone grease (Dow Corning Corp., Midland, Mich.)
36-20-341	2 oz	DC 200 silicone lubricant, 200,000-centistoke viscosity (Dow Corning Corp., Midland, Mich.)
36-20-092	16 oz	Cosmolubric 270 (E. F. Houghton & Co., Philadelphia 33, Pa.)
36-20-141	1 oz	Anderol L-793 (Lehigh Chemical Corp., Chestertown, Md.)
		Chlorothene (Dow Chemical Co., Midland, Mich.)
36-20-372	2 oz	Glyptal resin (General Electric Co., Schenectady, N. Y.)
36-20-391	4 oz	Epoxy resin (Hysol Corp., Olean, N. Y.)
36-20-392	4 oz	Epoxy hardener (Hysol Corp., Olean, N. Y.)
36-16-221	4 oz	Blue touch-up paint
36-16-224	4 oz	Charcoal gray touch-up paint
PH22.57		Buzz-track film
PH22.42		7000-cps film
Reg. 16		Steadiness film

### Section III Service Procedures

or guide (5) with toothpick or brush. Remove two screws (2) securing feed sprocket shoe cover (1) and remove cover. Remove four guide rollers (3) and wash rollers in Chlorothene. Lift follower assembly (5) away from sprocket (28, Figure 19), and blow out dust and other foreign material with compressed air. Start projector (by depressing RUN pushbutton) and brush sprocket teeth of film sprocket (28). Depress OFF pushbutton.

#### CAUTION

Hold brush at right angles to axis of each sprocket to prevent brush from being drawn between sprocket and shoe.

Wipe guide roller pins with cloth dampened with Chlorothene. Remove follower assembly (5, Figure 25 B) and dampener assembly (7) and wash in methyl alcohol. Apply a drop of Cosmolubric 270 to each roller shaft (pin) before reassembling rollers.

#### c. Optical System

(1) Projection Lens - Loosen lens lock screw (62A, Figure 19), and remove lens (56). Clean exposed surfaces of lens elements with lens cleaner.

#### CAUTION

Do not apply lens cleaner directly to lens elements; place a drop of cleaner on lens tissue and wipe surfaces of elements gently.

(2) Lamp House Compartment - Remove lamp house cover (26A, Figure 18). Remove lamp chimney assembly (86, Figure 19) and projection lamp (87). Clean interior of compartment, using cloth or compressed air. Clean exposed surface of filter element on safety shutter assembly (191) with lens tissue.

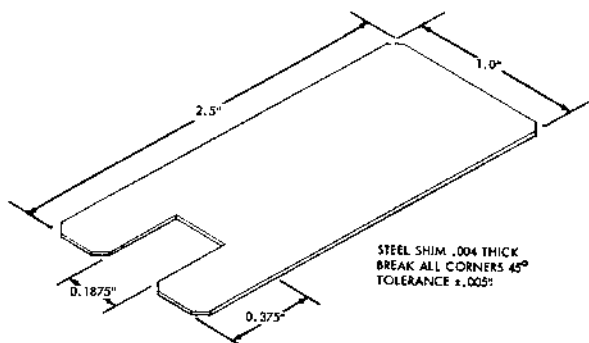

Figure 10. Feeler Gauge (Tool No. T-38000-Y)

d. Sound Optical System - Fold lens tissue over toothpick and clean exposed lens surfaces of sound optics cartridge (90, Figure 19) and photo-transistor in sound head (151). Do not remove sound optical system unless tests of equipment indicate such necessity. If removal is necessary, refer to paragraph E.9. in this section before proceeding.

e. Reel Belts and Spindles - Turn drive shaft (208, Figure 19) by hand, using manual advance knob (207), and wipe belts (1), spindles (2, Figure 20 and 20A), and spindle pulleys (11) with a cloth. Carefully remove lubricants and all foreign material from inside face (brake surface) of pulley assemblies (11).

f. Housing and Cables - Wipe with cloth dampened with Chlorothene.

## 2. Internal Parts

Remove projector assembly from case as described in paragraph E.1.

a. Rear Compartment - Clean interior of rear compartment with cloth or compressed air.

b. Drive Gears (See Figure 19) - Wipe drive gears (185 and 205) with cloth saturated with methyl alcohol. (This can easily be accomplished while slowly rotating the manual advance knob.) If take-up clutch lever (138) and film feed shaft (170) assemblies appear excessively soiled, disassemble and repair as described in paragraphs E.6. and E.4. of this section, respectively. Wash metal parts with Chlorothene; wash plastic parts with methyl alcohol. Use compressed air to dry parts, and reassemble. Apply No. DC 44 grease to gears.

c. Blower and Blower Housing - Remove blower motor as described in paragraph E.13. Direct stream of compressed air into blower wheel and around housing to remove accumulated dust.

## E. DISASSEMBLY AND REPAIR

1. Removal of Projector Assembly - Disconnect power cord (2, Figure 17) from receptacle (46, Figure 18). Lay projector on its back side. Remove two screws (33, Figure 18) from top of projector housing, four screws (2 and 3) from left side of amplifier cover assembly, and two screws (4 and 5) from bottom of switch cover assembly. Remove screw (12, Figure 16) securing elevating foot (11) and remove foot (11). Push rod (51, Figure 19) up into projector case, and lock rod (51) firmly in place.

### CAUTION

Carefully push elevation rod up into projector case, using a socket wrench which fits on end of rod (51) and is not too loose. Release of rod (51) while pushing into case may cause injury to hands; release of elevation lock lever (48) while projector is on its back side may cause injury to any part of the body within the protruding distance of the rod (51) outside of the projector case.

Remove four screws (6 and 7, Figure 16) and washers (8) from base of projector assembly.

#### Note

Lock washers (6A and 8A) are used with washers (8) on current models. Add lock washer (6A) to screw (6), and lock washer (8A) to each of the three screws (7) when reassembling.

Remove four screws (42, Figure 18) retaining receptacle plate. Pull off amplifier control knobs (1). Remove amplifier cover assembly (7 through 17) and switch cover assembly (18 through 27).

#### Note

To minimize distortion of the control switch cover, washers (23A) have been added (current models only) to the screws (23) which secure the switch (22) to the cover (27). When reassembling the switch cover assembly, add a washer (part no. 38473-P7A) to each of the two screws (23) between the cover (27) and the switch (22).

Set projector in the upright position. Grasp projector assembly (32, Figure 18) by reel arms (2 and 69, Figure 19), tilt forward, and carefully remove from case. Support projector assembly on Projector Holding Fixture T-38001-A (Figure 2).

### CAUTION

Remove projector assembly from case carefully to prevent damaging painted surfaces of parts. Do not rest projector assembly on a workbench, since this may result in damage to projector parts, short circuiting, or electrical shock.

## 2. Supply and Take-up Reel Arm Assemblies

a. Removal (See Figure 19) - Disconnect and remove take-up and supply reel belts (1). Remove stop nut (70), washers (3, 71 and 72), and roll pin (4). Remove arms (2 and 69), both arm lock plungers (5 and 5A), and both arm lock springs (6).

#### Note

To minimize the possibility of pinching the belt between the housing and the arm, one of the two washers (3, Figure 19) on the take-up reel arm is being replaced in current production models by another washer (part no. 35473-P56H). When reassembling the take-up reel arm, replace the first (in order of reassembly) of the two washers with this washer (3A).

b. Disassembly - Disassemble as shown in Figure 20 or 20A. Use Roll Pin Extracting Tool T-38000-A to drive out pin (3).

c. Repair and Reassembly (See Figure 20 or 20A) - Check bearings (7 and 10) for wear, and replace as required. Replace spindle assembly (2) if bent or otherwise damaged. Do not attempt to stretch reel brake spring (9). If spring is stretched, there is considerable danger that feed tension will be excessive and film sprocket holes will be damaged. Refer to Figure 20 or 20A when reassembling arms.

#### Note

Ensure that the cork reel brake used on early production models has no grease on its surface when the arm is reassembled. If the problem of loose take-up or loose rewind is encountered, warped or stretched ("long edge") film is the most probable cause. Replace the film in such cases, if possible. New offset reel arm spindles, which have minimized the effect of loose take-up caused by warped film, should be installed. A thicker collar (6, Figure 20A) has been made available to facilitate this change (order part No. 38097-P2). Use of the thicker collar necessitates a pulley assembly (11) with a longer shaft (order part No. 38094-G2).

Refer to Figure 19 when installing arms. When installing supply reel arm assembly (69), tighten stop nut (70) sufficiently to prevent free movement of arm.

#### Note

A new arm lock plunger (5A) is being installed in current production models to prevent dragging of the supply reel belt on the projector housing. Replace the arm lock plunger, part No. 38089, in older models with the new type, part No. 39032-G1 (beneath the supply reel arm only).

## 3. Feed and Take-up Sprocket Shoe Assemblies

a. Removal (If Necessary) (See Figure 19) - Remove screw (40) and stripper (39). Remove screws (41) and feed sprocket shoe assembly (40A). Remove retaining rings (12), screw (18), spring (17), and take-up sprocket shoe assembly (11A).

Section III  
Service Procedures

b. Disassembly - Disassemble remaining parts as shown in Figure 25A or 25B.

Note

A redesigned feed sprocket shoe assembly (see figure 25B) is being incorporated in current production models of all reversing projectors (15 and Super 15 models) to reduce the possibility of film damage when shifting from forward to reverse operation. Two of the four rollers (3), used in all other models, have been replaced with a dampener assembly (7) and spring (8).

c. Repair and Reassembly - Clean metal parts of shoe assemblies with Chlorothene and plastic parts with methyl alcohol. Check for damage and excessive wear. Replace any damaged assembly. Lubricate rollers (3, Figure 25A) and rollers (3, Figure 25B) with Anderol L-793. Lubricate rollers of follower assembly (5, Figure 25B) and dampener assembly (7) with Cosmolubric 270. Reassemble parts in accordance with Figures 25A and 25B.

4. Film Feed Shaft Assembly

a. Removal (See Figure 19) - Loosen set-screw (29) and remove sprocket (28). Remove screw (169) and belt guard (168). Pull out film feed shaft assembly (170).

b. Disassembly - Disassemble remaining parts as shown in Figure 22.

c. Repair and Reassembly - Check for damaged teeth on gears (12 and 13, Figure 22) and for excessive shaft and bearing wear.

Note

Replace the complete film feed shaft assembly in 15 or Super 15 models marked with the E2K (or earlier) production code. Replace the three Lexan gears (12, Figure 22) of the film feed shaft assembly in 10 or Deluxe models marked with the A2E (or earlier) production code. Use the new type (made of Zytel) used in current production models. Replace carrier (11) and pulley assembly (8) at the same time and install washers (5), (6A) and (9), as required. Add second retaining ring (4A). When replacing sprocket (28, Figure 19), ensure that it is same type as take-up sprocket. (A new type, part No. 38839-P1, is used in current production models.)

Check carrier assembly (11) for bent or broken pins. Replace defective parts as required. Reassemble in accordance with Figure 22. Use care that assembly runs freely when reassembled; if gears bind, there is danger of damage to the assembly. Lubricate teeth of gears (8, 12, and 13) and studs of carrier (11) with No. DC 44 grease.

Note

Before installing, reshape belt guard (168, Figure 19) by flaring the sides (older models only) as shown in Figure 19. The flared portion should rest against the projector housing when the guard is positioned centrally around the pulley of the film feed shaft assembly (170). Apply Glyptal resin to the guard and the screw (169) to prevent shifting of the guard position.

5. Drive Motor Assembly

Note

If stalling of the motor is experienced when operating Model 10 projectors from a low voltage source of primary power, connect a 0.5 uf, 600-volt capacitor, part No. SK 1281-P3 in parallel with the motor-start capacitor (166, Figure 19). If replacement of capacitor (166) is necessary, replace with part No. 38177-P3, which is a 3.5 uf capacitor.

Current production models of the 15 and Super 15 projectors include a capacitor and relay assembly (see Figure 25H) to reduce stalling.

a. Removal (See Figure 19) - Loosen set-screws (126A and 127A) and remove fan (126), pulley (127), and drive belt (128). Examine drive belt (128) for cuts, holes, or significant scratches which might reduce its strength; replace, if necessary. Loosen retaining screws (130), remove clamps (129), and remove motor (132) from motor cradle (135).

b. Repair and Reassembly - Check receptacles on motor (132) for wear or corrosion and replace as required. Replace drive motor (132) if defective. Check rubber motor mounts (133) for tightness. If mounts (133) are loose, perform the following procedures:

Note

Since removal of the motor assembly (132) is necessary to perform the following procedures, incorporate the applicable modifications described in paragraph 5.c. of this section.

Check orientation of gap in outer metal ring of each motor mount (133). Rotate mounts (133) if necessary so that the gap in each mount seats against solid portion of motor cradle (135). The smooth portion of each rubber mount (133) should be facing outward. Clean area between hub and ring with methyl ethyl ketone using a brush to remove all soil around the inner surface of the metal ring and mounting hub. Use sparingly and dry thoroughly with a clean cloth. Prepare a small amount of epoxy resin as follows (use Epoxy Patch Kit #60, procurable from Hysol Corp., or its equivalent): Use any flat surface of a discardable nature (a piece of glass is recommended).

### CAUTION

Do not allow uncured epoxy materials to contact skin. In the event of contact, wash immediately with hot water and soap and rinse with methyl alcohol. Keep containers of epoxy materials capped at all times.

Squeeze a length of base resin onto the mixing surface, using uniform pressure to maintain an even bead. Then, squeeze a bead of hardener onto the surface so that it is equal in length to and parallel with the bead of base resin. Mix with a wooden spatula until base and hardener are of a uniform color. Do not mix more than can be used at one time. Apply mixed resin at 3 points between spaces in mounting ring and hub with a wedge shaped spatula. Tamp the resin into the space to ensure that it fills the space completely between the two surfaces. Lay a light bead around the entire area in fillet form. Repeat the procedure for other motor mount (133), reassemble motor (132) to motor cradle (135) with clamps (129) and retaining screws (130). Tighten retaining screws (130) firmly. Replace drive belt (128), pulley (127), fan (126), and setscrews (126A and 127A). Apply a drop of Glyptal resin to screws (130) to prevent them from loosening. Allow motor to stand 1 to 2 hours at 72° to ensure that resin has hardened before starting motor or moving projector. Resin will cure completely in 30 hours.

c. Modifications - An electrical interlock assembly has been designed to prevent possible damage to the projector (15, Deluxe 15, and Super 15 models only) caused by operator error. In earlier machines, engagement of the rewind lever with the Graflever (threading control lever) set in REVERSE position could cause damage to the take-up clutch mechanism. The new interlock assembly will prevent operation of the projector drive motor if rewind operation is attempted when the projector is set for reverse operation.

Remove motor (132), cradle (135), clutch assembly (138), and belt guard (168) from projector.

Remove retaining ring (3, Figure 23) from link (2) and slide latch (1) from link. Install new latch assembly, part no. 39013-G1, as shown in Figure 23 and reassemble link (2) to pawl assembly (10), using a new retaining ring (3). Remove actuator from latch assembly to allow latch to pass between the framing arm of the claw arm assembly and the projector housing. Apply a drop of Glyptal resin to the retaining screw when reassembling. (If take-up clutch lever requires servicing, it should be accomplished at this time.) When attaching latch assembly to shaft of rewind lever, use two new retaining rings (38, Figure 19), part no. 252-2, to insure positive retention (with minimum end play).

Break off the copper shorting clip from the reversing switch (147, Figure 19) by bending to break loose. (Only the wires connected to the terminals between the shorting clip will be affected.)

Remove post (209A, Figure 19) and screw (209B) from projector casting. Install switch assembly (209D) as shown by inserting original belt guard retaining screw (169) with lock washer (169A), part no. 230-6, through switch assembly bracket and belt guard. Insert screw (209B) with lock washer through bracket hole, through hole in casting, and into post (209A). Adjust switch assembly by moving bracket until it engages actuator when rewind lever is at rest. Apply Glyptal resin to threads of screw to secure. Readjust latch link if required. Dress wire leads from switch assembly along existing wire harness, taping in three places. Remove yellow lead (left side) from terminal of reversing switch and attach yellow lead (with adapter) from switch assembly to this terminal. Re-attach yellow lead to adapter. Remove other yellow lead (right side) from terminal of reversing switch and attach to adapter on left side. Connect blue wire from switch assembly to right terminal of reversing switch. Three wires should now be connected to the left terminal of the reversing switch: the two yellow wires originally connected to the right and left terminals and the yellow wire from the rewind interlock switch assembly. Insure that all wires clear the sound head flywheel (149) by a minimum of 1/4 inch. Replace the three motor cradle retaining screws, part no. 131-10R8H, with new screws, part no. 116-10R7H. Use a lock washer (136A), part no. 221-10, with each of two of the new screws. Install an insulator (136B), part no. 39021, under the third screw. (Secure the new screws in place by applying Glyptal resin to the threads before installation.)

### 6. Complete Take-up Clutch Lever

a. Removal (See Figure 19) - Remove pin (4), retaining springs (137 and 144), retaining rings (38) and complete take-up clutch lever (138).

#### Note

Adjust spring tension (if too weak) by removing one turn from the old spring. The take-up clutch lever spring, part no. 38101-P1, is now obsolete and is replaced by spring, part no. 38845-P1. (137).

b. Disassembly (See Figure 23) - Remove two retaining rings (6) and washer (5). Place a metal motor pulley, part no. 38474-P2, over the axle and turn assembly over so that the hub assembly (4) rests on the pulley.

### CAUTION

Use extreme care to avoid contamination of lubricated felt with foreign materials since any foreign substance may damage the gear assembly (139, Figure 19).

Lift the lever assembly (20) carefully away from the complete inner assembly being careful not to disturb the orientation of components.

c. Repair and Reassembly (See Figure 23) - Check ratchets (16) and (18) for nicked or broken teeth. Replace ratchet (18) with metal ratchet 39005-P1 on all machines with reverse. Replace spring (17). Be sure

### Section III Service Procedures

teeth of ratchet (18) point in proper direction and end of spring (17) is inserted in hole in ratchet. Inspect hub assembly (4) and pulley assembly (12) for wear. Replace if balls (14) leave worn grooves. Also inspect surface of pulley (12) for wear or roughness where spring (17) fits over hub.

Check felt on hub assembly (4) for damage or excessive wear. Lubricate felt with No. DC 44 grease as follows: Apply uniform, thin layer of lubricant to glass or metal plate. Roll clutch felt over lubricant and work it into felt until felt is saturated.

Carefully replace lever assembly (20); turn assembly over and attach one retaining ring (6) to hold components in place. Adjust end play as described in paragraph E.8.a. Adjust latch link (2) as described in paragraph E.8.b. Continue reassembly.

#### Note

Be sure that all surfaces requiring lubrication are adequately lubricated with FS-1290 grease and that all parts move freely after assembly. Too little end play will cause binding; too much end play may allow a coil of the clutch spring (17) to be caught between outer ratchet (18) and hub of pulley (12).

If complete disassembly is necessary, clean all metal parts with Chlorothene and plastic parts with methyl alcohol, and reassemble as follows (see Figures 11 and 23): Place hub assembly (4) on a clean piece of paper with the tube end up. Apply a small quantity of FS-1290 grease around base of tube. Distribute 19 steel balls (14) around base close to tube. Slide pulley assembly (12) over end of tube with pulley groove toward hub assembly (4). Next, place a small quantity of FS-1290 grease in the recess in the top end of pulley assembly (12) and distribute 19 steel balls.

Place inner ratchet (16) on pulley assembly (12). (Ratchet teeth should point in a clockwise direction as viewed from above.) Place spring (17) on pulley assembly (12) and insert raised end (end with 1/32 inch gap between tail and adjacent coil) of spring into hole of inner ratchet (16). End of spring should not protrude through gear. If necessary, face off end of spring. Place outer ratchet (18) (teeth pointing counterclockwise) on end of tube, first engaging end of spring with hole in ratchet. Apply FS-1290 grease to washers (19) and (5) and slide them on shaft of lever assembly (20), the small washer (5) first and the larger washer (19) next. Slide shaft of lever assembly (20) thru hole in tube of hub assembly (4). Push hub assembly (4) up against washer (19). While holding firmly in place turn over entire unit so that hub assembly (4) is on top. Apply thin layer of FS-1290 around outer diameter of thick spacer (15) and insert spacer in tube of hub assembly. Push spacer down slightly below top of tube to form a race for the ball bearings. Apply a layer of FS-1290 in this race and insert eleven ball bearings. Proceed in the same manner with the remaining spacers (15) and (13) and steel balls. Place washer (5) on shaft. Place one retaining ring (6) on shaft and proceed to adjust the end play as described in paragraph E.8.a. Align pawl (10) to unwind spring (17) allowing pulley (12) to turn freely in the rewind position. Align lip on pawl (10) to contact the full

width of a tooth in the rewind position without touching pulley (12). Adjust latch link (2) until pawl assembly (10) is held tightly against lever (20) with projector running in the rewind position.

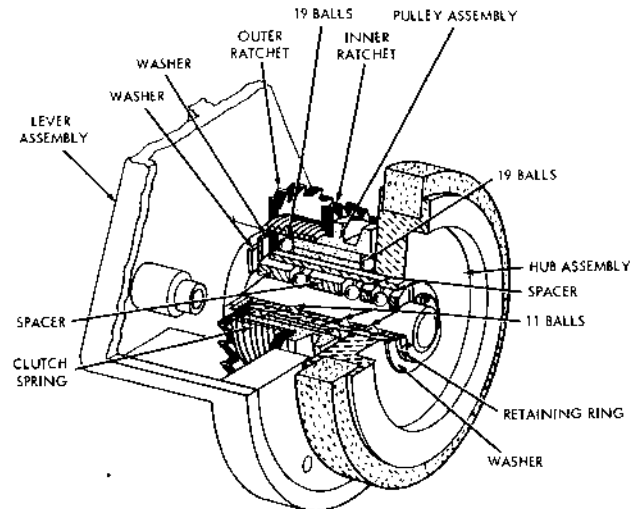

Figure 11. Cutaway View of Take-up Clutch Lever

## 7. Main Drive Shaft Assemblies

a. Removal (See Figure 19) - Remove film feed shaft assembly, drive motor assembly, and complete take-up clutch lever (paragraphs 4, 5, and 6, respectively). Remove screw (8), SOUND/SILENT lever (7), retaining rings (10), cam spring (9), and speed change clutch (11).

#### Note

The screw (8) securing the SOUND/SILENT lever is being replaced in current production models by a slightly longer screw part no. 104-6R6H. Either type screw, however, may be used as a replacement item.

Remove screw (146) and belt shift guide (145). Remove roll pin (142) from step pulley (141) with Roll Pin Extracting Tool T-38000-A (Figure 3). Remove step pulley (141), washer (143A), and take-up spring (143). Pull off manual advance knob (207). Loosen setscrews of worm gear (185), and slide gear forward off shaft. (If projector is equipped with a bearing retainer, loosen setscrews (203) and (204), screw (186D), speed nut (186E), and retainer (186C). Remove retaining rings (201) and loosen setscrews of worm gear (205) or (206A), collars (188) and (202), safety shutter (191), and shutter and cam assembly (192). Pull main drive shaft (208) out front of projector, removing assemblies from rear of shaft as clearance permits. Remove bearings (210).

b. Disassembly of 2-3 Blade Shutter Assembly (See Figure 24) - Remove retaining ring (2), cam (13), fixed blade (4), washer (5), inner blade (6), washer (5), and outer blade (7). Remove springs (8) and shutter actuator (9).

Note

The function of the shutter and cam assembly has been improved by the addition of a spacer (1) and a bumper (3). Both the cam (13 or 18) and the hub (12 or 19) which must be replaced as a matched pair, may be obtained by ordering part no. 38844-G1 (for Super 15 models) or part no. 38844-G2 (for other models).

c. Repair and Reassembly - Wash metal parts in Chlorothene and plastic parts in methyl alcohol. Check main drive shaft for warping or other damage. inspect worm gears for nicks, cracks, or broken teeth. Ensure that area between step pulley grooves is free of nicks or rough edges that might damage main drive belt.

CAUTION

Do not use chlorine-base solvents on plastic parts, as these solvents will cause damage in the form of crazing, cracking, and shattering.

Replace damaged or worn parts as required. Reassemble shutter assembly, using new retaining ring (2, Figure 24). Should cam or hub show damage requiring repair, return the complete shutter and cam assembly to Graflex for rebuilding. Hubs are "bored in assembly" and cams are balanced for the individual shutter used. For this reason, it is important that hubs and cams not be changed from shutter to shutter. Early Galaxy models are equipped with a bearing retainer assembly (see Figure 19); later production uses a spring "wave washer" bearing retention (see 187, Figure 19).

If difficulty in reverse operation, change in claw pin protrusion, or formation of film loop was encountered during operation of a projector having a bearing retainer assembly or a spring "wave washer," remove cone-pointed setscrews (189, 190, 203, and 204, Figure 19) used to secure collars (188 and 202) to shaft dimple. If setscrews are 1/8-inch long and have 118° cone shape, replace with 3/16-inch setscrews having 90° cone shape (Graflex part no. 171-F6-3L).

If projector being serviced has neither bearing retainer nor wave washer, parts required to convert to bearing retainer assembly configuration should be procured from Graflex and installed as follows (see Variation IV, Figure 19): Slide new collar onto shaft (counterbore to front). Press collar to inner bearing race and tighten cone-pointed setscrew into shaft dimple. Tighten cup-point setscrew. Slide retainer (186C) into position over top of casting and assemble speed nut (186E) and screw (186D). Secure retainer (186C) with screw (186D), ensuring that shaft bearing (210) is squarely seated in casting; retainer tabs must bear on inner bearing race and exert pressure. Locate retainer tabs within 1/32 inch of vertical diameter as viewed from the front.

Slide worm gear onto shaft (gear end first); using finger pressure, push gear against collar and tighten two setscrews.

Early step pulleys have been replaced with pulley assembly (141), part no. 39019-G1. Use of new pulley assembly requires replacement of the original helical spring, part no. 38031, with new helical spring, part no. 38482-P1 and its associated cap washer, part no. 38481; spirol pin of original type (part no. 190-6-9) is used with the new pulley. Cap washer should be slid onto shaft first and followed with spring and pulley.

Continue reassembly in accordance with Figure 19, using Roll Pin Inserting Tool T-38000-B (Figure 4) to replace spirol pin (142) in pulley assembly (141). Replace retaining ring on 2-3 blade shutter and ensure that no cam end play exists. Reset claw pin protrusion, pull-down, and side clearance before operating projector. (Refer to paragraphs E.6.b., E.6.c., and E.6.d.)

c. Cam Lubrication Kit Installation - Install cam lubrication kit, part no. 39002-G2, into all projectors. The kit consists of two parts: the pad assembly, part no. 39002-G1, and the retainer, part no. 39001 (see Figure 11A). Proceed as follows: Remove all lubricant from cam surfaces of shutter and cam assembly (192, Figure 19) with Chlorothene. Dry surfaces thoroughly. Lubricate pad with 0.5 cc (25 drops) of Cosmolubric 270. Install pad into projector, so that it rests on cam surface; slide the spring wire behind the heat shield in front of lamp housing, as shown in Figure 11A. (Pry heat shield away from projector housing with

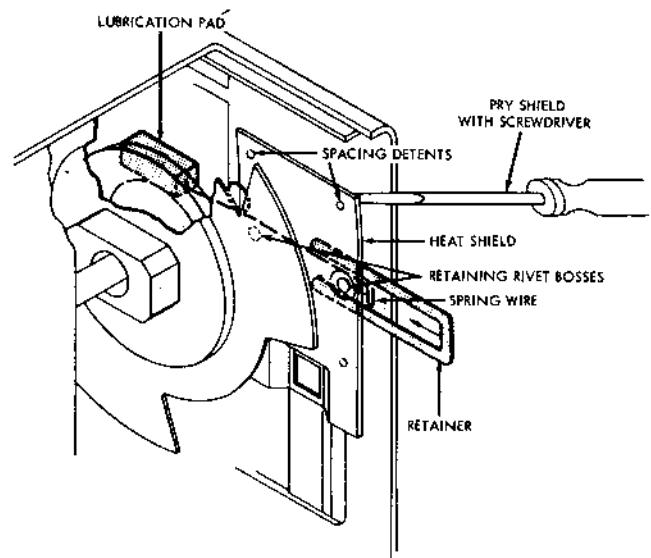

Figure 11A. Cam Lubrication Kit Installation



### Section III Service Procedures

screwdriver to allow wire to slip below topmost pair of spacing detents.) Position wire against the two retaining rivet bosses and slide the retainer fully inward to retain pad assembly.

#### 8. Complete Claw Arm

a. Removal (See Figure 19) - Remove screws (177 and 182), limit plate (176), and bracket (181). Remove pivot (173), washer (174), and complete claw arm (172).

b. Disassembly (See Figure 25) - Remove retaining rings (2) and plate (1); screw out framing rod (3) and remove pivot (4). Remove nuts (6 and 7) securing stud (8), and pin (9) securing spring (5). Remove spring (5), damper (10), and stud (8). Remove setscrews (17), nuts (11), flat washer (12), and spring washer (13).

#### Note

Add a wear washer (13A), part no. 38473-P12 between bushing (16) and washer (13) in older models to minimize bushing wear, thereby reducing the change in claw pin protrusion with use.

Remove bushing (16), claw arm assembly (18), washer (14), framing arm assembly (19 and 20), and pivot (15).

c. Repair and Reassembly (See Figure 25 - Check for damage to claw arm assembly (18). Replace parts if necessary and reassemble claw arm assembly. Adjust for proper tension between claw arm and framing arm at pivot as described in paragraph E.6.a. of this section. Check for correct claw pull-down and claw pin side clearance and readjust (if required) as described in paragraphs E.6.b. and E.6.c. of this section. Measure pin protrusion and adjust (if necessary) as described in paragraph E.6.d. of this section

#### 9. Complete Sound Head

#### Note

A waxy appearing substance used as a preservative during manufacturing and handling has proved to cause slow, uneven rotation or binding of the sound head. Removal and cleaning of the assembly will relieve the condition.

a. Removal (See Figure 19) - Remove screw (150) securing flywheel (149), and remove flywheel (149). Loosen screws (152), and pull out complete sound head (151) with drum assembly inserted.

b. Repair and Reassembly - Wash metal parts removed in Chlorothene. Check wires connecting phototransistor and plug for worn insulation. Check sound drum and shaft for wear or damage. If damaged, return sound head assembly to Graflex for rebuilding.

Run an aperture brush through the oilite bearing (Figure 11B) to remove all traces of foreign material. Re-lubricate with Cosmolubric 270 and reassemble. Secure flywheel with a new retaining screw (150, Figure 19), part no. 38160-P2, adding a lock washer (150A), part no. 39030, between flywheel and ball bearing race. Secure support assembly retaining screws (152) with Glyptal resin.

#### 10. Complete Threading Control Arm

a. Removal (See Figure 19) - Remove screw (102) and lock washer (103) securing threading control spring assembly (101), and remove spring assembly (101). Remove control lever (33), two retaining rings (118), reverse switch cam (121), spacers (119 and 120), and complete threading control lever (117).

b. Disassembly (See Figure 21) - Remove screw (4), lock washer (5), cap (3), and film tension arm (6). Remove retaining ring (8), spring (7), and washer (9).

#### Note

The spring (7, Figure 21), which is a part of the complete threading control arm, has been modified. The new spring (used in current models) has one more turn, eliminating the need for the washer. When replacing the spring (7) used in older models, use the new type and discard the washer.

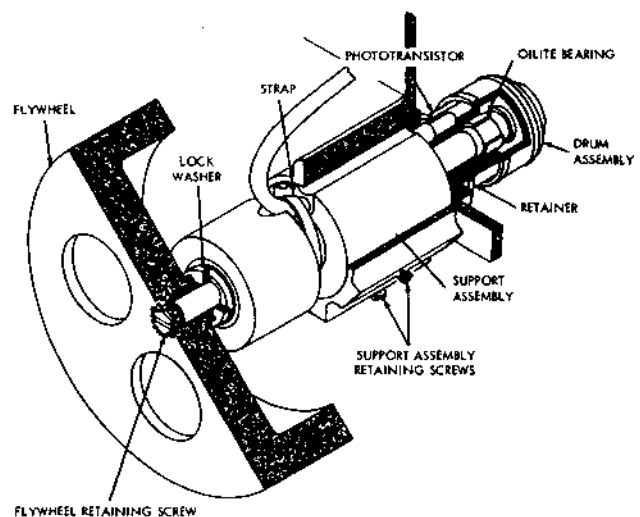

Figure 11B. Cutaway View of Sound Head

c. Repair and Reassembly (See Figure 21) - Wash parts in Chlorothene. Check hub for scratches or signs of wear. Check rollers (1) for worn spots or nicks. Replace parts as required. Reassemble, applying No. DC 200 lubricant to outer surfaces of hub and damper arm pivot. Apply Anderol L-793 sparingly to roller shafts. Reassemble retaining rings to permit 0.005-0.015-inch roller end play. When reassembled, rotate film tension arm assembly fully counterclockwise and release; arm should return to original position within 3 to 8 seconds. Check position and form of return spring if this specification is not met. Also, check for quantity of lubricant and end play of damper arm.

11. Pressure Roller Arm Assembly (See Figure 19)

a. Removal - Remove two retaining rings (123) and spring washer (123A) (Current models only) securing pressure roller arm assembly (122) and remove assembly (with roller assembly (97)).

Note

When replacing pressure roller arm assembly in older models, add washer (123A), part No. 224-4, to take up end play on pivot.

b. Disassembly - Remove nut (98), roller assembly (97), washer (99), and spring (100) from pressure roller arm assembly (122). Remove screws (125) securing stud assembly (124) and remove assembly (124).

c. Repair and Reassembly - Wash parts in Chlorothene. Check pivot and stud assembly (124) for scratches or signs of wear. Check roller assembly (97) for worn spots or nicks. Replace parts as required.

Note

A slight reshaping of the "L" shaped slot in the pressure roller arm assembly (122) will result in smoother movement of the arm when the Graflever is rotated to the FORWARD position. File off the inside corner of the "L" shaped slot to a 1/8-inch radius.

Reassemble, applying Cosmolubric 270 to surface of pivot. Apply Anderol L-793 sparingly to shaft of stud assembly (124).

12. Complete Reel Tension Arm (See Figure 19)

a. Removal - Remove screw (27) securing tension arm spring (26); remove retaining ring (21), spring (26), and reel tension arm (22 through 25).

b. Disassembly - Remove screw (23) securing film tension roller (22) and remove washer (24) and roller (22) from arm (25).

c. Repair and Reassembly - Wash parts in methyl alcohol and check for wear or damage to roller (22). Reassemble tension arm, loading

spring (26) 220° in a clockwise direction before inserting into tension arm slot. (Use Spring Loading Tool T-38001-M (Figure 5)). Apply Anderol L-793 to roller shafts sparingly.

13. Blower Wheel Motor Assembly (See Figure 19)

a. Removal - Disconnect blower wheel motor leads. Remove screws (157) securing transformer assembly (153) and venturi plate (158); remove assembly and plate.

Note

A special transformer assembly (153 inset, Figure 19) is used in units intended for operation from 50-cycle primary power sources. The transformer is tapped to allow operation of the projector from 50-cycle sources of 117 volts, 205 volts, 225 volts, or 245 volts. An access door is provided in the rear of the case to facilitate changing of the connections (projectors are shipped with the wires attached to the 245-volt taps). A decal showing the proper connections for operation of the projector from any one of the other three sources of power is provided. Only the violet and blue wires are involved in changing the connections for operation from a primary power source other than 245 volts. Disconnect the violet wire from the 245 V. VIO. (LO) tap and the blue wire from the 245 V. BLU. (HI) tap. Connect the violet wire to the VIO. tap and the blue wire to the BLU. tap corresponding to the primary power source used.

The mounting of the special transformer assembly is similar to that of the standard transformer assembly (153). A bracket, however, is added to provide more support. The bracket is replaceable, but is included as a part of the transformer when replacements for the transformer are shipped.

The speed nut (155) attaching the transformer assembly to the transformer bracket has been replaced in current models by a nut (155), part No. 200-6HH, and a lock washer (155A), part no. 220-6. A longer screw (154), part No. 116-6R6H, is therefore used. Also, a longer screw (157), part No. 121-8R8H, is now being used to attach the bracket to the housing.

Note

One of the screws (157) has been replaced in more recent models by a longer screw (157A), part No. 121-8R12H, to accommodate the addition of a capacitor and relay assembly (see Figure 25H). This assembly may be installed in older models as follows: Remove the upper screw (157) securing the right transformer bracket (156) to the housing. Remove nuts (155) and lockwashers (155A) from screws (154) securing transformer assembly (153) to brackets (156). Replace nuts (155) and lock washers (155A), fastening

Section III  
Service Procedures

Note (cont)

the extending portion of the capacitor and relay assembly chassis against the bottom of the bracket (156). Secure the upper left corner of the chassis with screw (157A) and washer, part No. 230-6H. Insert a spacer, part No. 32090-28, between the chassis and the bracket (156).

Remove capacitor (166) and spring (167): push the capacitor inward to release it from lip of venturi plate (158). Disconnect leads from capacitor terminals. (This capacitor is replaced by the capacitor in the capacitor and relay assembly.) Connect the capacitor and relay assembly components as shown in the applicable schematic diagram, Figure 14 or 15.

Remove screws (159) securing blower motor mounting plate assembly (160 through 165), and remove plate assembly (with motor).

b. Disassembly - Loosen setscrew (161) on motor shaft and remove blower wheel (160). Remove screws (163), lock washers (164), and plate (165).

c. Repair and Reassembly - If troubleshooting indicates a damaged motor, refer to parts list for motor replacement. Remove dust or carbon deposits from motor windings with compressed air. Reassemble, taking up motor shaft play toward motor to obtain a clearance of 0.135 inch between plate (165) and wheel (160). Rotate wheel (160) to ensure it clears heads of screws (163) in all positions.

#### 14. Complete Amplifier

Note

The amplifier circuit is mounted on a component board which plugs into the amplifier chassis for fast and convenient removal.

a. Removal - Disconnect all amplifier leads. Remove two screws (3, Figure 18) and amplifier chassis.

Note

A change in the amplifier circuit has been made in more recent models of the Galaxy projectors. The ratings of two capacitors were changed in order to eliminate low-frequency oscillation, or "motorboating," sometimes encountered when the projector is used with a large external speaker system. If this problem is encountered in older models, replace capacitors C-11 and C-12 (Figure 12). Capacitor C-11 should be replaced with a 0.1 uf, 600-volt capacitor (14, Figure 27), and C-12 should be replaced with a 0.1 uf, 200-volt capacitor (13, Figure 27).

b. Servicing - Check amplifier and power supply for frayed wires and burned or damaged components. If only one diode (17, Figure 28) is used, add a second diode in parallel. Connect leads of the diode to terminal strip (29) as shown in Figure 12A, so that its polarity is the same as that of the first, and solder in place.

#### CAUTION

Do not apply excessive heat to transistor or crystal diode terminals. Remove transistor (22, Figure 28) from socket (24) before applying soldering heat to socket terminals. When removing or replacing diode (17), bend diode leads by grasping leads near diode body with long-nose pliers and bending leads against outside of pliers. Use the pliers as a heat sink when removing or re-soldering diode in place. Grasp diode lead between point of attachment (or terminal) and diode with pliers while applying heat to terminal. Do not remove pliers until joint has cooled. Dress diodes as close to the chassis as possible: one above and one below the terminal strip.

Recheck exciter lamp voltage with exciter lamp in place and illuminated (allow 15 minutes for warm-up). Reset voltage, if necessary, to 3.9 volts by adjusting rheostat (27). If voltage cannot be adjusted by this method, replace transistor (22).

Check all tubes (1, 2, and 4, Figure 26) and transistor (22, Figure 28) and replace as required.

#### CAUTION

The pins of the transistor type required vary in diameter, according to the manufacturer of the transistor used as a replacement. Poor contact of the transistor pins with the socket terminals may result, causing failure of other components. Ensure proper contact by crimping the socket terminals before inserting the replacement transistor into the socket.

Current speaker-microphone jacks are identifiable by a red dot on the plastic for the microphone side and a green dot for the speaker side. Early assemblies did not have this identification. Substitute old style assemblies with new style assemblies as follows: Remove speaker and microphone lead wires at AMP fitting. Loosen and remove retaining screw located between jacks, and remove old jack and jack shield. Install new jacks, and re-attach jack shield, speaker leads, and microphone leads. Replace printed circuit board and amplifier cover. Attach green lead to terminal next to green dot and red lead to terminal next to red dot.

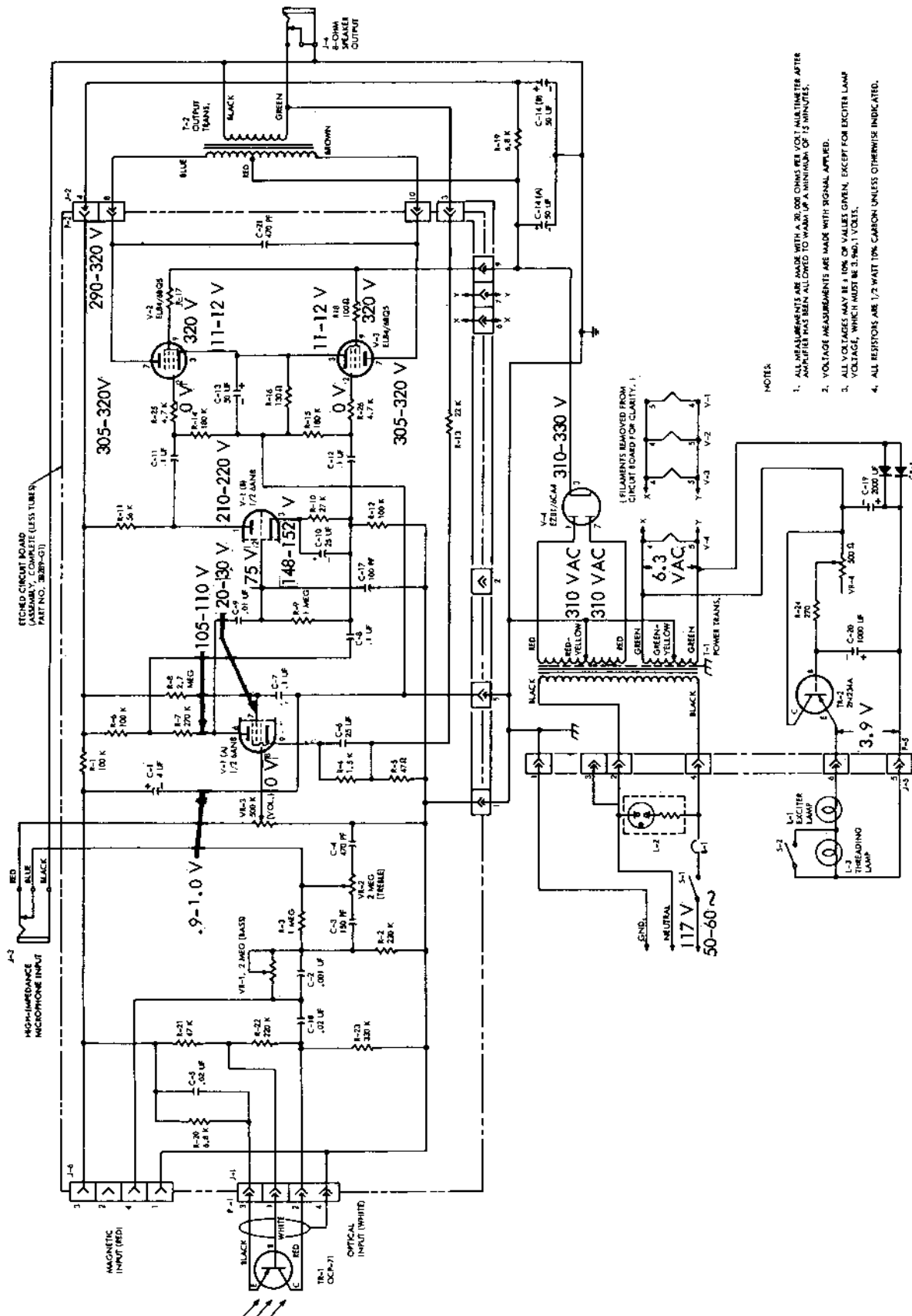

Figure 12. Schematic Diagram, Galaxy Projector Amplifier

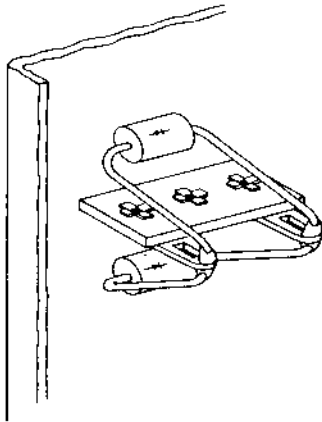

Figure 12A. Installation of Second Diode

## 15. Miscellaneous Assemblies

### a. Removal

(1) Elevation Rod Assembly (See Figure 19) - Remove nut (70) from supply reel arm assembly (69). Remove screw (49) securing LOCK lever (48) and remove lever (48). Remove spring (50) and elevation rod assembly (51). Replace the nylon clamp used in older models with the new brass clamp (52), installed in current production models. (The first brass clamps produced were 0.491 inch high; the height of recently produced brass clamps is 0.437 inch.) The 0.437-inch high clamp requires two washers (55) to fill the space between the bosses on the housing. One washer is placed against the top side of the clamp and the other against the bottom. The brass clamps are threaded, eliminating the need for the nut used with the nylon clamp.

### Note

Early Galaxy models do not have washer (53).

(2) Lens Holder Assembly (See Figure 19) - Loosen lens lock screw (62A) and remove projection lens (56). Release gate lever (64) and pull out complete film pressure shoe (72A). Remove screw (40) and stripper (39). Loosen setscrew (29) and remove feed sprocket (28). Remove screw (41) and feed sprocket shoe assembly (40A). Loosen setscrew (66) and remove gate lever eccentric (65). Slide lens holder assembly (57 through 65) from projector and remove spring booster (67) and lens holder spring (68)

### Note

Booster spring (67) was not used in some early Galaxy models. However, if missing, this spring should be ordered from Graflex and installed as shown in Figure 19.

(3) Aperture Plate Assembly (See Figure 19) - Remove four screws (81) securing aperture plate assembly (80A) and remove assembly.

(4) Projection Lamp Socket Assembly (See Figure 19) - Remove chimney assembly (86) and projection lamp (87). Remove screw (89) securing lamp socket (88) and remove socket (88) (remove leads from socket).

(5) Sound Optics Cartridge (See Figure 19) - Loosen setscrew (92) with Allen wrench and carefully remove cartridge (90).

### Note

Replace setscrew (92), part No. 171-G6-4L, in older models with setscrew, part No. 171-6-4L, to reduce distortion of plug (91).

(6) Exciter and Threading Lamp Sockets (See Figure 19) - Remove exciter lamp (105). Remove screw (110) securing cable clamp (109); remove clamp (109), washers (112), and spacer (113). Remove screws (108), washers (112), and spacers (113) and lift out lamp socket (106). Remove screw (107) securing threading lamp socket and remove socket (114). Disconnect socket leads.

### Note

A new type cable clamp (109, Figure 19) is installed in current production models. The new clamp (part No. 267-2) allows a better fit for the cable and should be substituted for the clamp (part No. 267-1) used in older models. Add a second clamp and relocate the existing clamp in older models to prevent interference of the cable with the reverse switch assembly (147). The clamps should be attached to the two uppermost holes in the exciter lamp socket. Replace one of the short screws (108) with the longer screw (110) and add another washer (112) when installing the second clamp.

(7) Reversing Switch Assembly (See Figure 19) - (Models 15 and Super 15 only) - Disconnect leads from reversing switch. Remove two screws (148) securing reversing switch assembly (147), and remove switch assembly (147).

### b. Disassembly

(1) Elevation Rod Assembly (See Figure 25F) - Slide bumpers (1) (only one bumper in early models) and washers (2) off rod (3).

(2) Lens Holder Assembly (See Figure 19) - Remove screw (62) securing lens holder spring assembly (61) and remove spring assembly (61).

(3) Complete Film Pressure Shoe (See Figure 25C) - Remove screws (2) securing shoe assembly (1) and remove shoe assembly (1) and springs (3). Remove screws (5) securing film guides (4) and remove washers (6), guides (4), spring (8), and shoe adjusting plate (7) from shoe mounting plate (9).

Note

Inspect film pressure shoe (72A) for irregular surface conditions. If such irregularities exist, replace complete film pressure shoe (72A) as an assembly with new unit (part No. 38472-G1) obtained from Graflex.

c. Repair and Reassembly

(1) Elevation Rod Assembly (See Figure 25F) - Clean rod (3) with Chlorothene. Replace washer (2) in earlier models with washer, part No. 38473-P11; slide washer (2) on rod (3) first. Slide two bumpers (1) on rod (3) (add the second bumper in earlier models; if the existing bumper is not black, replace it with bumper, part No. 38209.)

Lubricate rod (3) with No. DC44 grease. Place clamp (52, Figure 19) between casting bosses and slide elevation rod assembly (51) through nyloners (209) in bosses. Ensure that rod moves smoothly but not loosely through the clamp. Rotate lever and ensure rod is locked securely with lever in horizontal position.

Note

When installing the new brass clamp (52), be sure to place a washer (53) on the stud (54) between the lever (48) and the housing. Ream the stud hold in the projector housing to 0.290 inch in diameter to provide necessary clamp clearance. After inserting the stud through the hole in the housing, place another washer (53A) on the stud between the clamp (52) and the housing. The screw (49), part No. 104-6R5H, securing the lever (48) is being replaced in the current models by a slightly longer screw, part No. 104-6R6H. Either type, however, may be used as a replacement item.

(2) Lens Holder Assembly - Wash lens holder and gate lever parts with Chlorothene. Remove projection lens and clean lens surfaces with lens cleaner. Wipe lensholder housing with cloth dampened with Chlorothene. Reassemble, applying No. DC 44 grease to lensholder guides.

(3) Complete Film Pressure Shoe - Clean parts of film pressure shoe with cloth dampened with methyl alcohol or clear water. Reassemble and insert film pressure shoe beneath springs of lensholder assembly until springs snap in place.

Note

When reassembling complete film pressure shoe (1 through 9, Figure 25C), check type of film pressure shoe (1) used in the unit. Units employing stainless steel or chromium-plated shoes must have a spring washer (78) installed under the head of each screw (77); early Graflex models contained thick beryllium - copper shoes, which did not require the use of the spring washers. All complete film pressure shoe assemblies, however, must contain part No. 38448 spring.

Adjust film pressure shoe to ensure even seating of shoe (1) in aperture plate channel and exertion of proper pressure when gate is closed. Shoe should be flat or its center portion should be curved slightly toward film aperture; if necessary, bend shoe slightly until this condition is met and check adjustment as described in paragraph E. 5 of this section.

(4) Aperture Plate Assembly - Clean aperture plate (4 or 9, Figure 25D) with cloth dampened with methyl alcohol or clear water. Remove deposits of dirt and emulsion from notches of aperture plate side tension spring (1, Figure 25D) or guide (5) with toothpick or brush. If a ragged picture edge is not corrected by cleaning the edge of the aperture plate, examine the edge for chips in the paint finish (older models only). If the finish is chipped, remove the paint from the edge completely with a fine abrasive. (The edge of the aperture plate in current production models is unpainted, thus reducing the occurrence of a ragged picture edge.) The entire aperture plate assembly (1 through 4, Figure 25D) in older models may be replaced with the type (5 through 9, Figure 25D) used in current production models. Two additional embossings have been incorporated on the plate (9) to assist in stabilizing the film guide, and the spring (1) has been replaced by a spring-loaded guide (5).

Note

1. Use Alignment Gauge G3-38000 to locate the proper aperture plate position. Refer to paragraph E.10 in this section for alignment procedures.
2. It may be necessary to readjust the pressure shoe tension when the aperture plate assembly is replaced. Refer to paragraph E. 5 in this section for gate tension adjustments.

(5) Projection Lamp Socket Assembly - Check for loose or damaged socket pins. Ensure that projection lamp seats properly in socket and that socket fits snugly against slot in projector casting, preventing any shift of socket. If projector is not equipped with lamp socket of type described, new socket should be obtained from Graflex and installed. When installing lamp socket, leg of socket base having red dot must be parallel with edge of lamphouse. Refer to paragraph E.9 of this section for optical path alignment procedures describing method for correctly positioning lamp socket.

### Section III Service Procedures

Check grip of three lamp socket "fingers" on lamp chimney. (If loose, chimney may tip forward during handling of projector, causing possible interference with operation of still shutter in Super 15 model or inefficient cooling in all models.) If necessary, bend "fingers" inward until chimney is gripped firmly (pay particular attention to "finger" at rear of socket).

(6) Sound Optics Cartridge - Fold lens tissue over toothpick and clean exposed lens surfaces of cartridge (90, Figure 19). No attempt should be made to remove lens elements. Hold unit in front of a bright light and look through unit from end adjacent to exciter lamp (105); a narrow, sharply defined and evenly illuminated beam of light should be seen. If beam is hazy or unevenly illuminated, send sound optics cartridge to nearest Graflex Service Department for repair.

(7) Exciter and Threading Lamp Sockets - Ensure wire ends extend through socket contacts and are securely soldered. Replace sockets as required and reassemble.

(8) Reversing Switch Assembly - Check that switch lever operates smoothly. Perform a continuity check on switch with lever in both positions.

#### 16. Projector Schematic Diagram

Electrical troubleshooting of the projector will be facilitated by reference to the applicable schematic diagram (Figure 13, 14, or 15).

### E. TESTS AND ADJUSTMENTS

#### 1. Forward Take-up Tension Measurement

(See Figure 15A) Load projector with 2000-foot reel of film and allow projector to run until approximately one inch of film has built up on take-up reel. Stop projector and pull a loop of film up between take-up sprocket and roller of reel tension arm. Insert roller of Film Tension Gauge T-38000-S in film loop and pull backward until film engages roller 180° as shown in Figure 15A.

Start projector and note scale reading of gauge. (Scale should indicate between 4 to 12 ounces throughout run of film: high with small amount of film on take-up reel; low when reel is full.)

#### 2. Reverse Take-up Tension Measurement (See Figure 15B)

##### Note

The following measurement is a general indication of reverse operation of the projector. If the measurement is within the limits given, no further measurements of reverse take-up tension are necessary; if the measurement does not conform to the prescribed limits, the measurements described in paragraphs E.3. and E.4. must be made to determine the cause of the trouble.

Engage film loop with roller of Film Tension Gauge T-38000-S after one inch of film has built up on forward reel. (Scale should indicate between 2 to 8 ounces throughout run of 2000 feet of film: high with small amount of film on supply reel; low when reel is full.)

#### 3. Net Reverse Drive Force Measurement

Attach Film Tension Gauge T-38000-S to a fixed object about 1 foot directly above supply reel spindle. Wind a length of film on a small reel to a thickness, or radius, of 1-1/2 inch and place the reel on the supply reel spindle. Attach end of the film (looped) to roller of gauge suspended above. (Adjust position of projector so that film is in a vertical plane.)

Start projector (in reverse) and rotate reel by hand in the forward direction (reducing tension applied to gauge) until the gauge indicates 2 ounces. Release reel and note the indication on the gauge when indicator no longer moves. Repeat this procedure at least 3 times, noting the indication each time. (The mean, or average, of the readings should be 6 to 10 ounces.)

#### 4. Reel Brake Tension Measurement

Clean supply reel pulley (11, Figure 20) thoroughly and remove reel belt (1, Figure 19). Using the same reel of film required for net reverse drive force measurement, place the reel on the supply reel spindle. With power to the projector removed, attach Film Tension Gauge T-38000-S to film loop. Slowly pull gauge in a horizontal direction and note the indication on the gauge. (The force applied to the gauge due the friction of the brake against the pulley should be 3 to 6 ounces.) If force is greater than 6 ounces, replace brake (12, Figure 20) and reassemble.

#### 5. Gate Tension Measurement (See Figure 15C)

Select a length of film that is not "green" but in good condition and make a loop in one end large enough for insertion of roller of Film Tension Gauge T-38000-S.

Insert film into channel of aperture plate assembly (80A, Figure 19) and close film gate. (Turn manual advance knob to retract claw pins.) Pull film up slowly and evenly with gauge. (Tension indicated by gauge as film moves through gate at a constant speed (not starting or accelerating) should be 2-3/4 ounces; limits are 2-1/2 to 3 ounces.)

#### 6. Claw Arm Adjustments

a. Claw Arm Tension (See Figure 25) - Place 0.002-inch feeler gauge between claw arm (18) and washer (14) separating claw arm (18) from framing arm (19 and 20). Tighten retaining nuts (11) until gauge can just be pulled out with firm pressure.

- Blu - Yel 118V, 60 CPS
- Red - Yel 21.75V, 11.6A
- Vio - Yel 118V, 60 CPS
- Red - Yel 17.5V, 9.3A

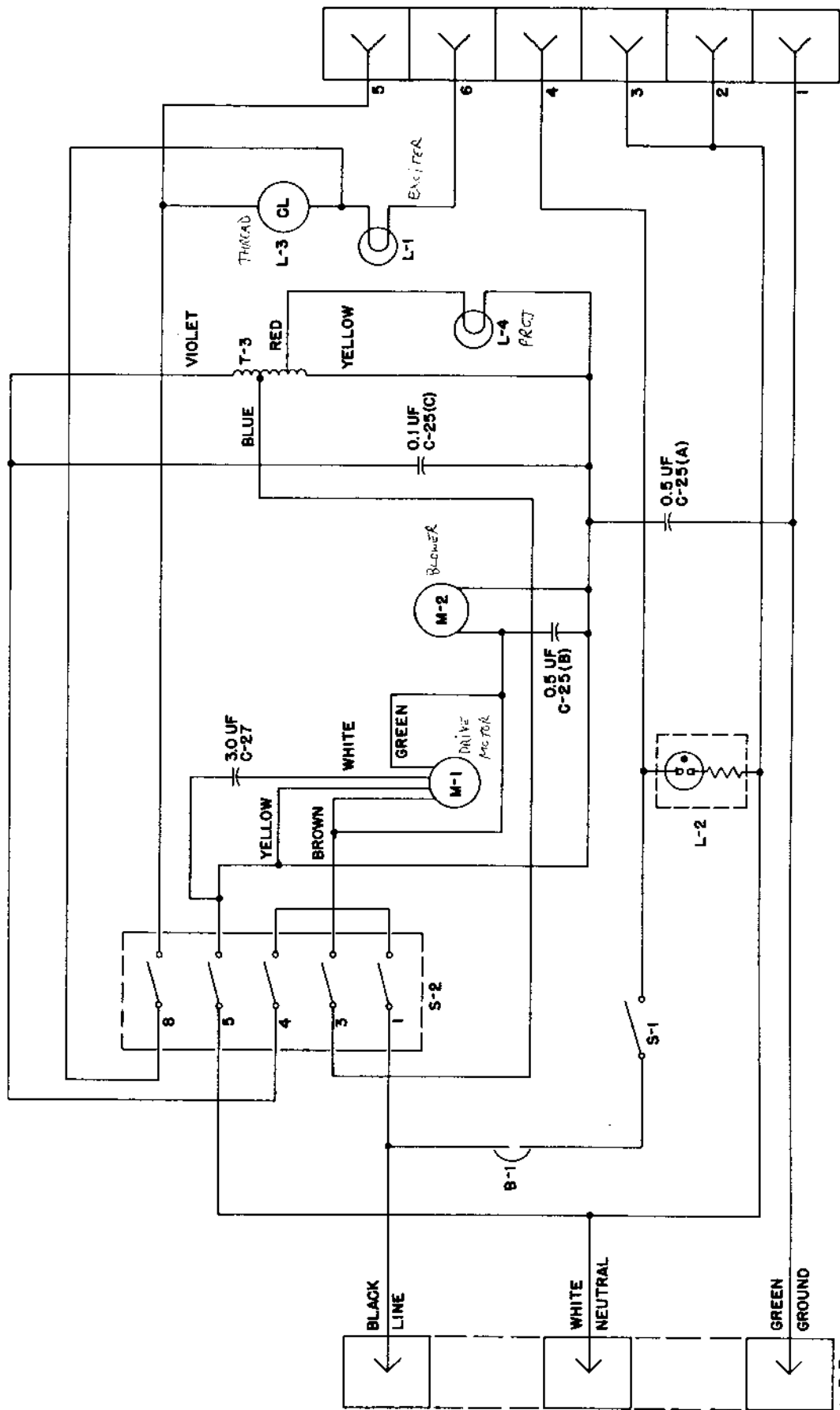

Figure 13. Schematic Diagram, Galaxy Models 10 and Deluxe Projectors



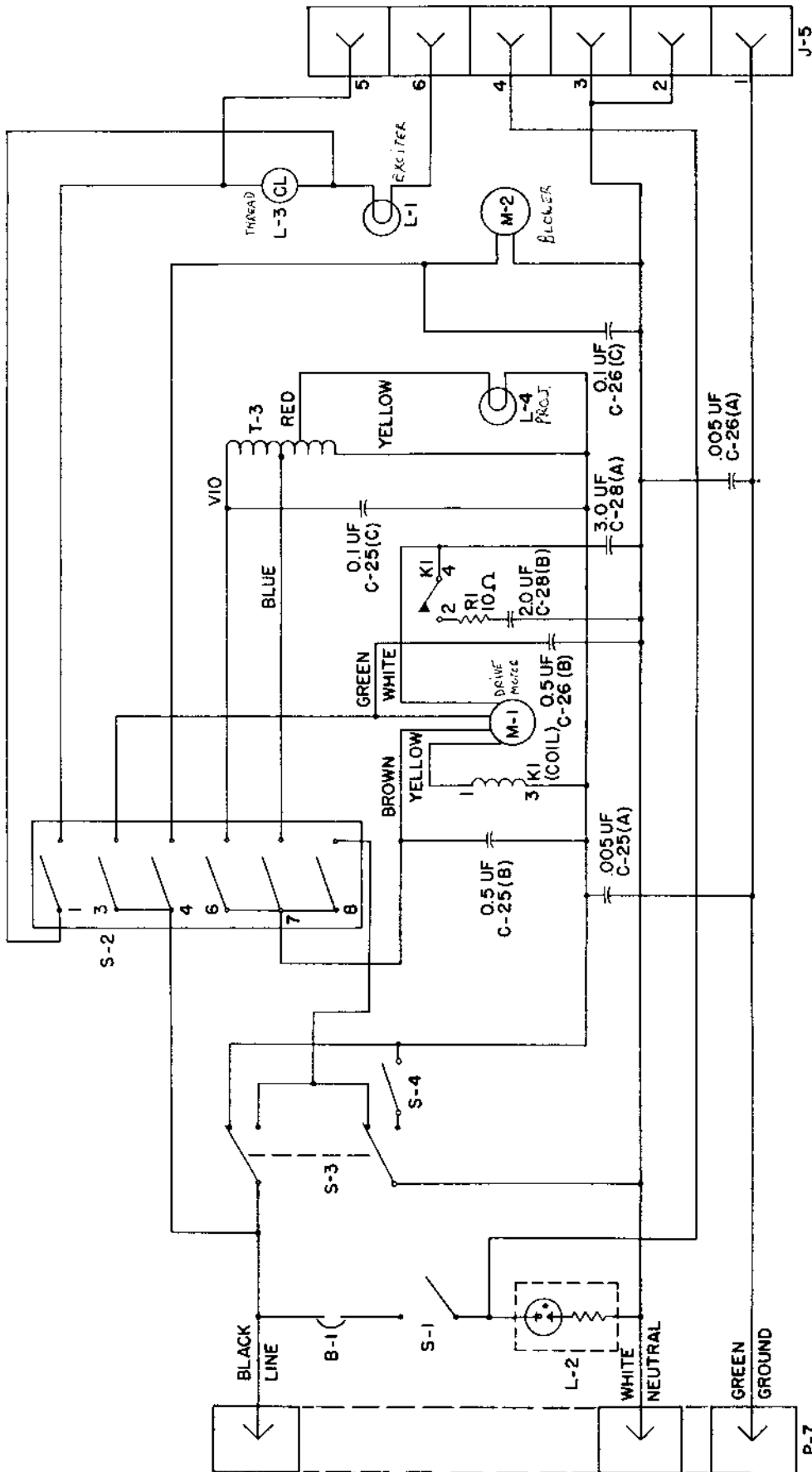

Figure 14. Schematic Diagram, Galaxy Model 15 Projector

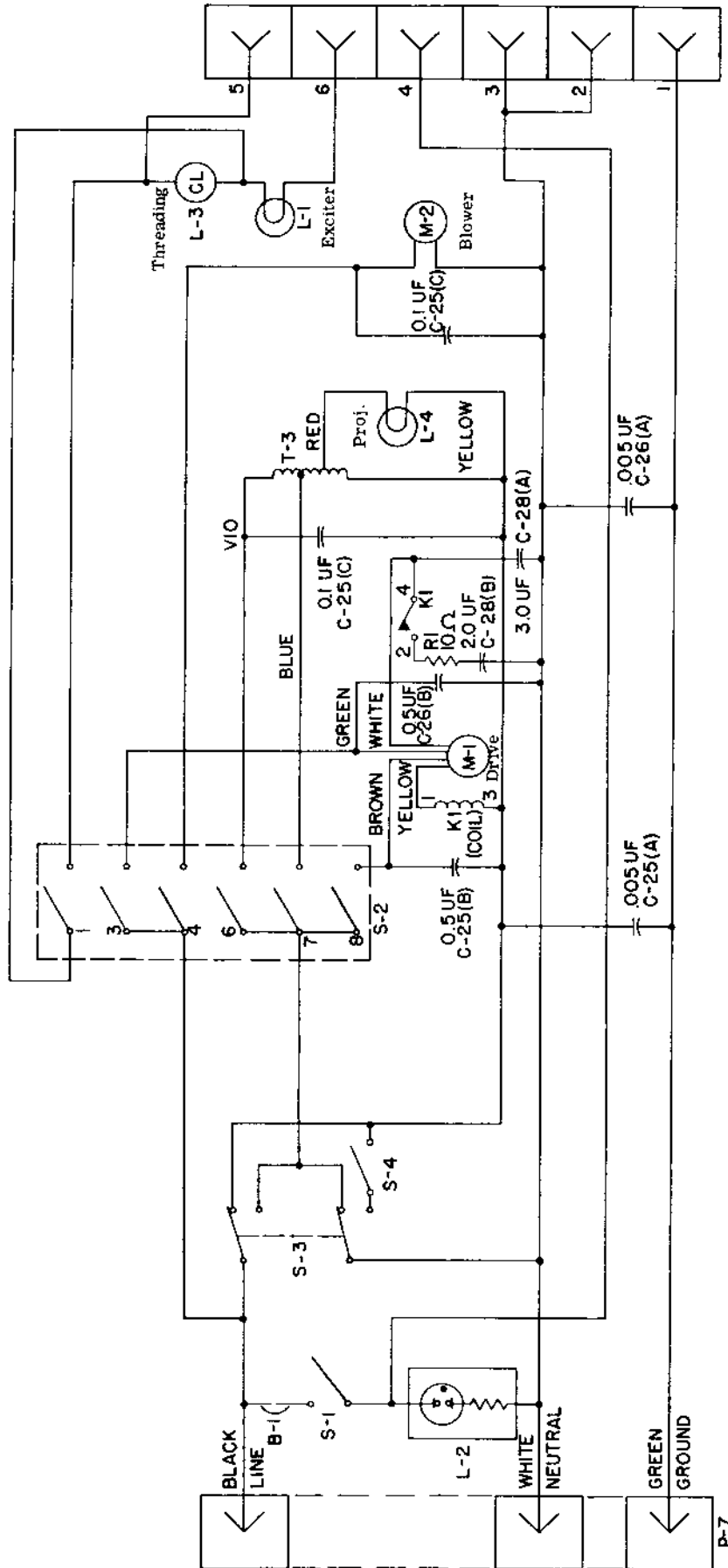

Figure 15. Schematic Diagram, Galaxy Model Super 15 Projector

Section III  
Service Procedures

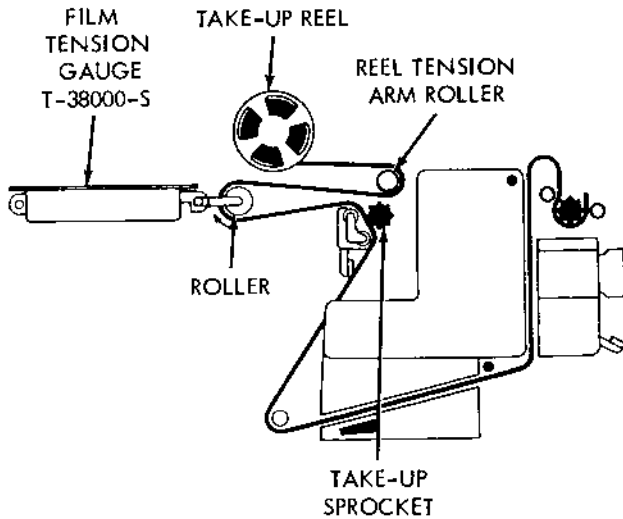

Figure 15A. Forward Take-up Tension Measurement

Note

Pull-down and side clearance adjustments, described in the following paragraphs, although described as separate procedures, must be performed simultaneously.

b. Claw Pull-down - Pull-down is measured with Stroke Setting Gauge ST-5880 and is adjusted with Shuttle Cam Adjusting Tool ST-5884 (Figure 6). Depress STILL pushbutton to illuminate projection lamp. (On all other Galaxy models, it is necessary to remove fan (126, Figure 19) and pulley (127) to prevent rotation of main drive shaft when power is applied to projection lamp.) Depress LAMP-NORM

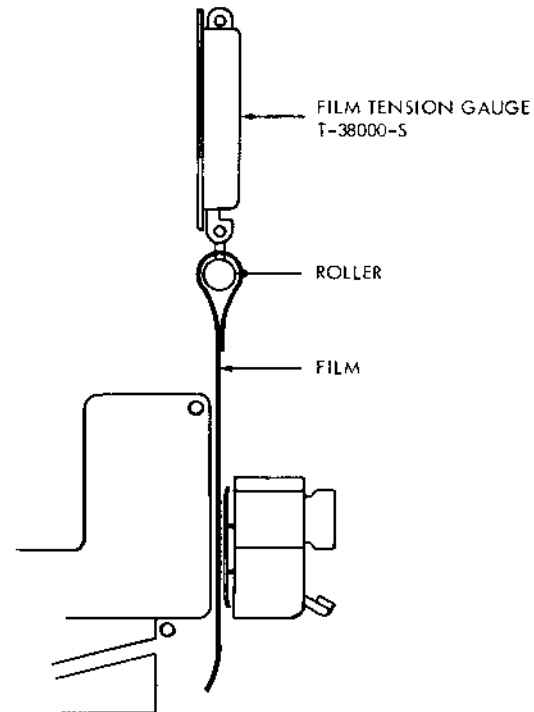

Figure 15C. Gate Tension Measurement

pushbutton to illuminate projection lamp at normal brightness. Insert gauge into film aperture and close gate. Rotate manual advance knob (207) to bring gauge step wedge into projection aperture. Continue to turn knob until claw has reached bottom of its stroke, withdrawn from gauge, and returned to top of stroke. Stop turning knob when claw pins have just inserted into gauge but have not started the downward stroke.

Focus image of gauge on a white surface about ten feet from projector and draw a straight reference line extension of lowest gauge step on the screen as shown in Figure 15D.

Push up on gauge until it seats firmly against pins; this will cause image on screen to move downward.

The distance of downward movement of image is the measurement used to determine pull-down. The image shown in (A) of Figure 15E represents minimum acceptable pull-down; the reference line on the screen is halfway between the lower (first) and upper (second) step of the image. Normal pull-down ( $0.3010 \pm 0.0005$  inch) is represented in the center illustration (B) of Figure 15E.

The second step of the image is coincident with the reference line. Maximum pull-down is represented by (C) of Figure 15E; the distance of the second step below the reference line is approximately half the difference ( $0.3010$  inch) between the first and second step.

Note

Pivot assembly (15, Figure 25) in framing arm is usually used to adjust side clearance. Bushing (16) in claw arm is usually used to adjust pull-down.

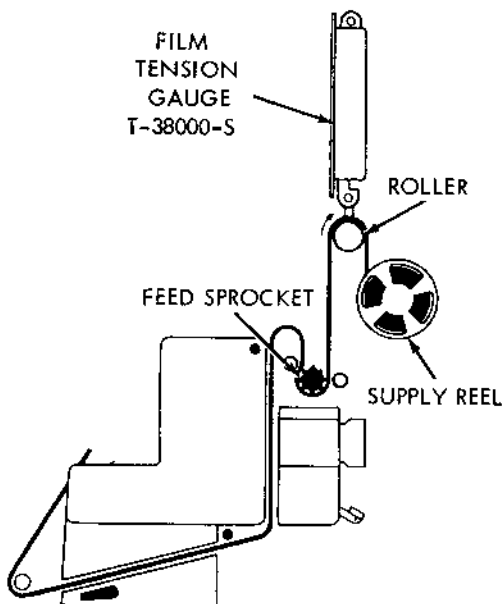

Figure 15B. Reverse Take-up Tension Measurement

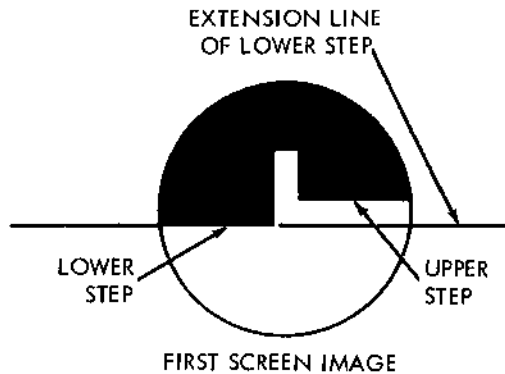

Figure 15D. Drawing Extension of Lowest Step

To adjust pull-down, loosen setscrew (17, Figure 25) at rear of claw arm and, while holding pivot assembly (15, Figure 25) with one Shuttle Cam Adjusting Tool ST-5884, rotate bushing (16) with other Shuttle Cam Adjusting Tool. (The direction of rotation is dependent on the results of claw pull-down measurement.)

**c. Side Clearance** - Check side clearance of claw pins and readjust as required by loosening setscrew at rear of framing arm and turning pivot assembly (15, Figure 25) with Shuttle Cam Adjusting Tool ST-5884 until side clearance of claw pins is 0.042 inch. Place short length of 0.042-inch drill rod between claw pins and edge of aperture plate. Rotate manual advance knob through one complete cycle of claw; pins of claw should just touch 0.042-inch drill rod, but in no case should bind against it. Adjust side clearance with the pivot assembly (15, Figure 25) and recheck pull-down; then, tighten setscrews (17).

**CAUTION**

Use care not to force claw when adjusting side clearance as force may result in breakage of claw pins.

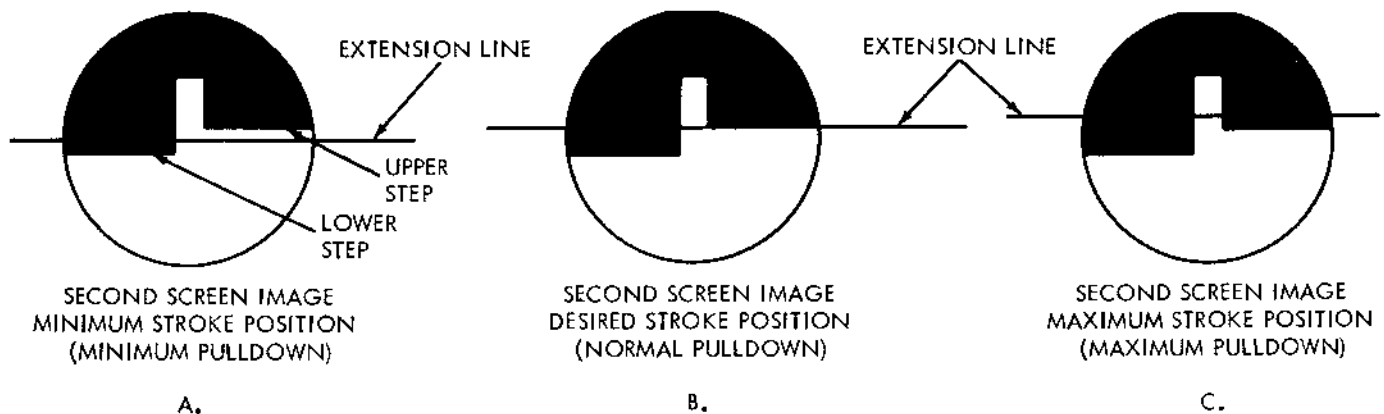

Figure 15E. Determining Pull-down (Stroke Position)

**d. Pin Protrusion** - Use Claw Arm Pin Protrusion Gauge G14-38000 (Figure 7) to measure pin protrusion, which should be 0.040 inch. At maximum pin insertion, pin should touch the first or 0.045-inch step of the gauge and should just clear the second or 0.035-inch step of the gauge. (Feel the back of the claw arm to determine amount of clearance.) To change pin protrusion, loosen setscrew (10 or 17, Figure 24) in hub (12 or 18) of shutter and cam assembly, and move assembly forward and back on shaft until proper protrusion is reached; then, relock hub of assembly on shaft.

**e. Claw Arm Spring Adjustment** - The claw arm return spring (5, Figure 25) is adjusted by using two Vertical Cam Wrenches T-38000-W. While holding nut (7) with one wrench, unlock nut (6) with the other wrench. The nut (7) is adjusted for proper tension and locked in place by tightening nut (6) against it.

**7. Sound Track Adjustments**

Loosen setscrews (92, Figure 19) with Allen wrench and carefully remove sound optics cartridge (90). Insert Sound Drum Locating Plug T-38001-G (Figure 9) in place of cartridge (90); align phototransistor in sound head (151) with locating tip at end of plug. Remove locating plug and replace cartridge (90).

Connect a-c voltmeter across speaker terminals and (using a 7000-cps test film) adjust position of sound drum optics cartridge (focus) for maximum output as indicated on voltmeter. Make a fine (optical slit) adjustment by using a 7000-cps test film and rotating sound drum optics cartridge (azimuth) until maximum output is indicated on voltmeter. Adjust guide roller (97) for proper lateral positioning of sound track by tightening or loosening

Section III  
Service Procedures

nut (98). Use "buzz track" test film to verify alignment of phototransistor with aperture in end of sound optics cartridge. Tighten setscrews (152).

8. Take-up Clutch Lever Adjustments

a. End Play Adjustment (See Figure 23) - Use Feeler Gauge T-38000-Y (Figure 10) to adjust the end clearance in take-up lever assemblies. Insert gauge between washer (5) and lever assembly (20). Compress assembly against feeler by pushing against retaining ring (6) with a metal drive pulley, part No. 38474-P1 (only one retaining ring should be in place at this time). Install the second retaining ring and remove the gauge.

b. Latch Link Adjustment - Adjust the latch link (2, Figure 23) by making a "Z" bend until the pawl (10) engages the inner ratchet (16) slightly before engagement of the rewind latch (1) with the carrier (11, Figure 22) of the film feed shaft assembly (170, Figure 19) at a little more than 1/2 of the travel of rewind lever (37, Figure 19). The latch link (2, Figure 23) must not hit the motor cradle casting boss. (See Trouble Analysis Chart).

9. Lamp Socket Alignment

Remove projection lamp from its socket and install plug of Lamp and Optical Path Aligning Tool (G3 - 38000).

**WARNING**

Disconnect AC supply before inserting plug of aligning tool.

Remove the projection lens and pressure shoe assembly. Insert optical path aligning assembly in place of projection lens, being sure to engage the locating bar with the lower lens holder guide rod. (See Figure 15F).

The aperture plate locating portion of this assembly should engage the hole in the aperture plate as shown in figure 15F. If it is necessary to align the plate follow procedure in paragraph E.10. before continuing. Turn manual advance knob until shutter is clear of aperture. Slide the aligning rod through the optical path aligning assembly. Lift up safety shutter so that it will be clear of rod, and insert

rod into lamp socket aligning plug. To align the lamp socket (88, Figure 19) loosen the retaining screw (89, Figure 19) and rotate plug until aligning rod may be inserted into the alignment hole of the lamp socket aligning plug.

Note

Some slight vertical misalignment may be noted.

When alignment is attained, apply Glyptal to the retaining screw threads and tighten screw. Apply Glyptal to the tab of the lamp socket which engages the projector casting to ensure that alignment is retained. Ensure that screen illumination is even after installation of socket. (A 50-percent corner-to-center-of-screen fall-off is acceptable.) If screen illumination is uneven, and correct socket has been installed and properly aligned, replace projection lamp. Do not modify lamp socket to obtain even illumination; some early lamps had abnormal variations not present in current production. Individual adjusting of bracket may be necessary whenever a lamp is replaced.

10. Aperture Plate Alignment

Loosen four retaining screws (81, Figure 19) slightly so that aperture can be moved. With the lamp socket aligning plug in position, insert optical path alignment assembly in the lens holder. (Be sure film gate is closed). Engage the lens holder lower guide rod and carefully slide the assembly rearward so that the aperture locating tip engages the aperture plate. This tip is tapered to more easily accommodate the insertion of the tool. With the tool firmly pressed against the sides of the aperture in the aperture plate ensure that top and bottom edges are in positive contact (see insert A). Slide the aligning rod through the optical path alignment assembly into the lamp socket aligning plug to establish both vertical and lateral alignment. Secure the aperture plate retaining screws.

After accomplishing the above described alignment, check side clearance of the claw arm assembly (18, Figure 25) and framing limit plate (176, Figure 19) adjustments to ensure that claw pins do not strike the aperture plate. Recheck film gate tension and stroke if adjustments have been necessary.

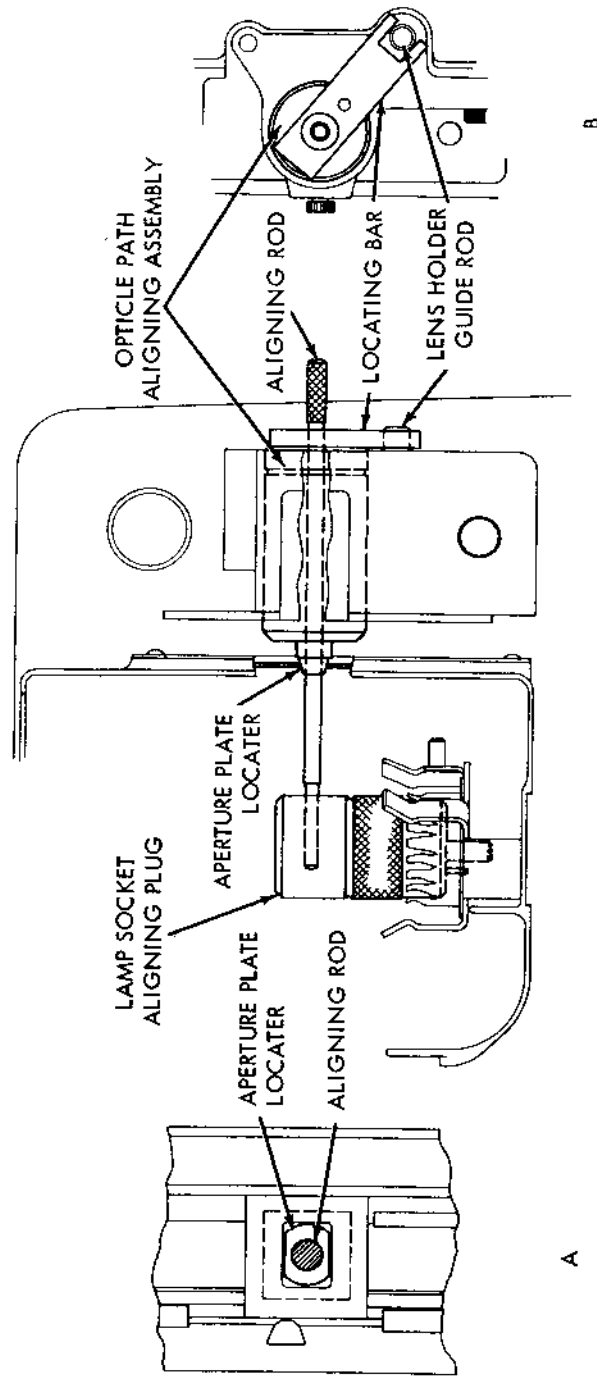

Figure 15F. Lamp Socket and Optical Path Alignment.