

FILM-TECH

THE INFORMATION CONTAINED IN THIS ADOBE ACROBAT PDF FILE IS PROVIDED AT YOUR OWN RISK AND GOOD JUDGMENT.

THESE MANUALS ARE DESIGNED TO FACILITATE THE EXCHANGE OF INFORMATION RELATED TO CINEMA PROJECTION AND FILM HANDLING, WITH NO WARRANTIES NOR OBLIGATIONS FROM THE AUTHORS, FOR QUALIFIED FIELD SERVICE ENGINEERS.

IF YOU ARE NOT A QUALIFIED TECHNICIAN, PLEASE MAKE NO ADJUSTMENTS TO ANYTHING YOU MAY READ ABOUT IN THESE ADOBE MANUAL DOWNLOADS.

WWW.FILM-TECH.COM

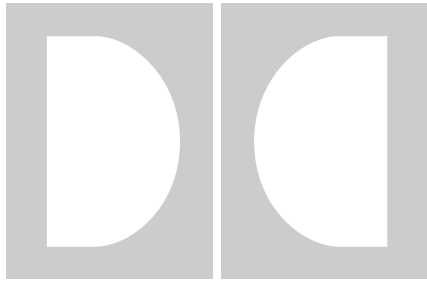

Dolby

Replacement LED Head Assembly Installation Guide

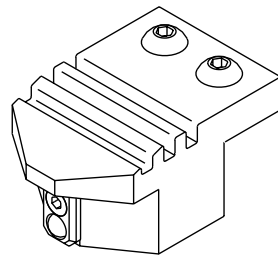

Part Number 83308

Dolby Laboratories Inc

U.S. Headquarters

Dolby Laboratories Inc
100 Potrero Avenue
San Francisco, CA 94103-4813
Telephone 415-558-0200
Facsimile 41-863-1373
www.dolby.com

U.K. European Office

Dolby Laboratories Inc
Wootton Bassett
Wiltshire SN4 8QJ England
Telephone (44) 1793-842100
Facsimile (44) 1793-842101



LED Light
DO NOT STARE INTO BEAM
CLASS 2 LED Product Per EN 60825-1:1996 1mW at 650-680 nm



Faisceau de LED
Ne pas rester dans le faisceau
LED Classe 2 selon EN 60825-1:1996 1 mW à 650-680 nm



LED Lichtquelle
Nicht in den Lichtstrahl blicken
LED der Kategorie 2 entspr . EN 60825-1:1996 1 mW bei 650-680 nm



L'indicatore del LED
Non guardare fissamente il raggio
Prodotto LED classe 2 secondo al EN 60825-1: 1996 1 mW a 650-680 nm



La luz LED
No mire fijamente al rayo de luz
Producto LED clase 2 según el estándar EN 60825-1: 1996 1 mW a 650-680 nm



LED ljus
Undvik att titta direkt in i laser strålen
Klass 2 LED produkt per EN 60825-1:1996 1 mW vid 650-680 nm



LED belichting
Kijk niet in de lichtstraal
Klasse 2 LED product volgens EN60825-1:1996 1 mW bij 650-680 nm



DISCLAIMER OF WARRANTIES: Equipment manufactured by Dolby Laboratories is warranted against defects in materials and workmanship for a period of one year from the date of purchase. All warranties, conditions or other terms implied by statute are excluded to the fullest extent allowed by law.

LIMITATION OF LIABILITY: It is understood and agreed that Dolby Laboratories' liability whether in contract, in tort, under any warranty, in negligence or otherwise shall not exceed the cost of repair or replacement of the defective components and under no circumstances shall Dolby Laboratories be liable for incidental, special, direct, indirect or consequential damages (including but not limited to damage to software or recorded audio or visual material), or loss of use, revenue or profit even if Dolby Laboratories or its agents have been advised, orally or in writing, of the possibility of such damages.

Dolby and the double-D symbol are registered trademarks of Dolby Laboratories.

©1999 Dolby Laboratories Inc

Issue 1
S99/12796
Part No. 91692

Introduction

In normal operation, the LED assembly used in the Cat. No. 701 Digital Soundhead will exhibit gradually reduced light output over its life. If it becomes necessary to replace the LED then follow the procedure outlined below. The LED assembly is Dolby Part Number 83308.

Installation

1. Turn off power to the Cat. No. 701 soundhead.
2. Remove the two screws that mount the LED assembly to the arm and carefully pull the LED assembly off of the pivot pin.

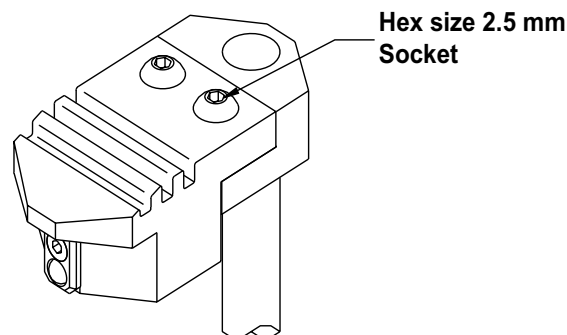

3. Carefully turn over the assembly. Loosen the two screw terminals and remove the wires. **Note the wire colors and terminal locations.**

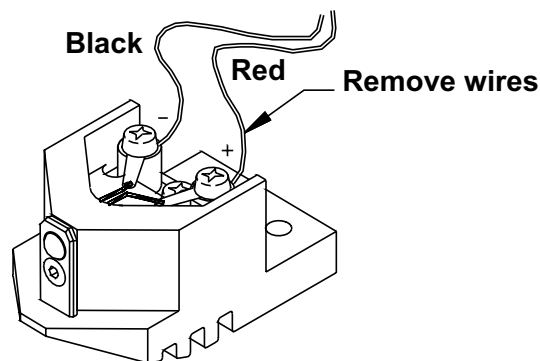

4. Attach the wires to the replacement LED assembly using the same wire locations as in the original LED assembly. The wires may require restripping since they have been compressed previously, and could be too weak. Inspect the wires carefully before attaching them to the terminals.

5. Remount the LED assembly onto the pivot pin. Initial adjustment can be made by tightening the screws slightly with a parallel gap between the rear of the LED assembly and the facing edge of the arm. Using a sheet of paper will usually provide the proper clearance.

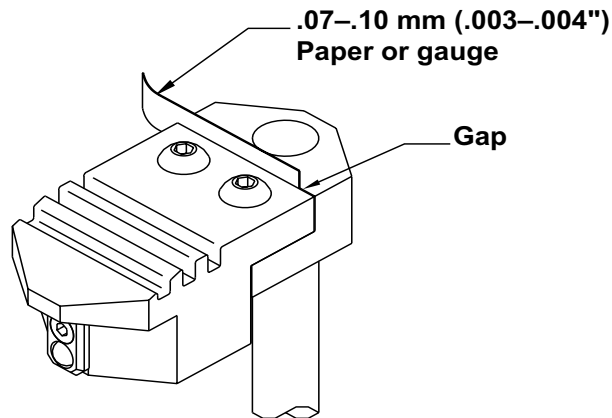

Alignment



Class 2 LED Product per EN 60825-1:1996. Do not stare into the red LED beam. Do not attempt to view the LED beam with any type of optical device.

1. Connect an oscilloscope (20 MHz minimum bandwidth) to test points on the video acquisition card (Cat. No. 670). Some digital oscilloscopes may not be usable for this procedure even though they may have the required bandwidth.
 - a. Ensure that the probes are 1X. Connect scope Channel 1 to the **Video** test point (TP1). Connect only this probe's ground to the **VGnd** test point (TP2).
 - b. Connect scope Channel 2 to the **Clamp** test point (TP3).
 - c. Set both channel vertical input sensitivity controls to 1 Volt/div, DC coupling. Set the vernier to **calibrated** (usually the inner knob- rotate until it "clicks").
 - d. Set horizontal sweep rate to 2 μ sec/div.
 - e. Set the trigger source to Channel 2 and positive polarity.
 - f. Turn on power to the digital soundhead and Dolby digital processor.
2. Set the oscilloscope display
 - a. Thread and play a Cat. No. 69T Dolby tone test film loop.
 - b. Display only Channel 2, and adjust trigger level to lock on to the clamp signal.
 - c. Adjust horizontal position to line up inside edge of left clamp signal with left screen graticule.
 - d. Adjust the time base sweep vernier to line up the inside edge of right clamp signal with right screen graticule.

- e. Select Channel 1 display.
- f. Temporarily switch the scope channel 1 input (video) to GND and adjust the vertical position to coincide with a horizontal screen graticule. This is the 0 V reference baseline.

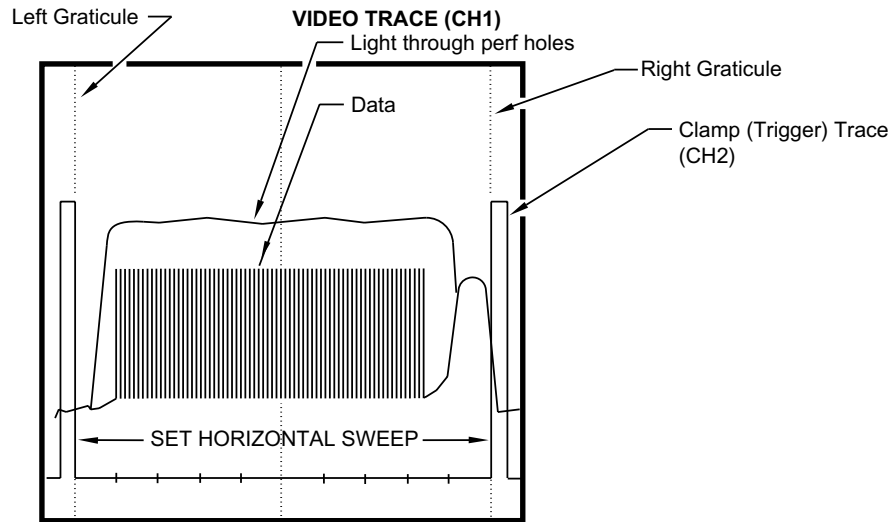

3. Adjust the LED Position

- a. Switch the Channel 1 video input coupling back to DC.

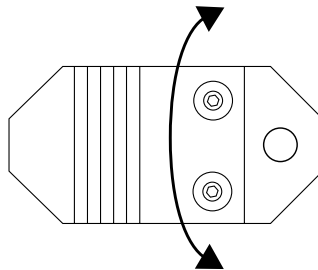

- b. Loosen the 2.5 mm hex screws and carefully rotate the LED assembly while watching the scope image. Adjust for maximum video signal voltage (unobstructed light through the perf hole) on the **upper trace**. Also, the waveform must be reasonably flat (fit within one scope major division). In other words, adjust for peak voltage with minimum ripple.

4. Check / Set LED drive current

The optimum peak video signal voltage (unobstructed light through the perf hole) is **4 V**, measured from the 0 V reference baseline to the **upper trace**. If necessary, adjust the Cat. No. 701 power supply output to achieve the correct video voltage. See the figure below for adjustment location (VR1). The back cover of the digital soundhead must be removed to gain access to the output adjustment.

