

FILM-TECH

THE INFORMATION CONTAINED IN THIS ADOBE ACROBAT PDF FILE IS PROVIDED AT YOUR OWN RISK AND GOOD JUDGMENT.

THESE MANUALS ARE DESIGNED TO FACILITATE THE EXCHANGE OF INFORMATION RELATED TO CINEMA PROJECTION AND FILM HANDLING, WITH NO WARRANTIES NOR OBLIGATIONS FROM THE AUTHORS, FOR QUALIFIED FIELD SERVICE ENGINEERS.

IF YOU ARE NOT A QUALIFIED TECHNICIAN, PLEASE MAKE NO ADJUSTMENTS TO ANYTHING YOU MAY READ ABOUT IN THESE ADOBE MANUAL DOWNLOADS.

WWW.FILM-TECH.COM

INSTRUCTION MANUAL

PRO-35/70

Projector Mechanism & Magnetic Reproducer



Ballantyne of Omaha, Inc.

1712 Jackson Street, Omaha, NE 68102, U.S.A.
402/342-4444, Telex 484481

A member of the Strong International team

ASSEMBLIES

SEE PAGE 5

**WHEN ORDERING PARTS, PLEASE USE
PART NUMBER AND NOMENCLATURE**

F O R E W O R D

The PRO-70 is a modern mechanism, streamlined and designed for a long life of unequalled performance. It continues the high standards maintained in Royal Soundmaster products throughout the years. The projector was primarily designed to work with the Ballantyne Model VII Soundhead.

The main frame is designed for ruggedness and simplicity. All driving gears are contained within the main frame and submerged in oil. No gears are visible on the drive side of the projector. The mechanism has been designed with roominess for ease of threading, operation, service and cleaning. The projector, designed for long life carries an unheard of five-year warranty on the mechanism with the exception of film wearing parts. As a result of the modern design, film wearing parts can be removed and replaced with equal ease.

Highest efficiency is obtained by the unique conical shutter positioned close to the aperture for maximum light efficiency. Apertures are easily replaced for any ration. Lens holder is designed to accept 4" diameter and 2-25/32" diameter lenses with complete prefocusing facilities, lens mount is of aluminum bar stock for positive anchorage and elimination of any frailty. The lens carrier is mounted on its base with a double "V" lens slide with a micro lens focus adjustment. A unique changeover system is a built-in part of the projector.

These are only a few of the salient features of the PRO-70 Projector. In order that all the many features of the PRO-70 may be fully realized, we recommend that the following instructions be studied carefully so that you have a thorough knowledge of this precision mechanism. Sprockets, pad rollers and wearing film parts are extremely easy to replace. Cleanliness is the only maintenance required.

The intermittent movement is of heavy construction with a large star and cam. Adjustment between the star and cam is accomplished by eccentric bushings easily adjusted. This service no longer requires the services of a skilled, experienced mechanic. The intermittent is driven by a small motor and the soundhead is driven by the projector, the reverse of competitive drives. Framing is accomplished by moving the intermittent sprocket with a delron sprial coupling completely free from the shutter. With this unique method, no other compensation is needed when the picture is framed. This completely eliminates shutter adjustment knobs to remove travel ghost from the screen and additional gears for compensation.

The film gate and trap are unique. They are made as an assembly and can be removed as an assembly, thereby eliminating the necessity of adjustment to keep the gate in perfect alignment to the trap. Though the film gate is a part of the trap assembly, the gate is easily removed by means of one screw for ease in cleaning. The film shoes in the trap can be adjusted for tension while film is being run. The opening and closing mechanism for the film trap incorporates a cam adjustment and can be adjusted while film is running for exact distance and tension of the gate and trap.

On the main frame, an oil drain is easily accessible so that oil could be drained in case of service, but the manufacturer recommends that oil never be changed in the projector. The unique design of this PRO-35 never requires oil or grease.

SPECIFICATIONS FOR BALLANTYNE PROJECTOR

The Projector is designed so as to meet or exceed all Academy standards for film speed, picture jump, weave and film protection.

Basic design is so that the projector can be as simple as possible, yet readily adaptable to accept the most modern and sophisticated equipment, making it the most versatile and deluxe projector on the market.

1. SPROCKETS. Sprockets are LaVeZZi VKF, 35 or 70, no combination. Both upper and lower sprockets are mounted to the drive shafts so that they are readily removable. All sprocket shafts are sealed ball bearing mounted.
2. PAD ROLLERS. Film is guided and held to upper sprockets by pad rollers mounted on a detent arm. Pad roller arms are so designed that adjustment can be made horizontally and vertically.
3. FILM TRAP. The film trap is designed so it is easily removed from center frame. Film trap is flat. Film trap shoe is hardened and ground steel mounted by means of screws. Trap is milled to accept snap-in type apertures for rigid positioning, yet are easily removed.
4. FILM GATE ASSEMBLY. Film gate assembly is a one-piece removable metal plate mounted on a slotted carriage, anchored by one screw.
5. LENS MOUNT. Lens mount is designed for instant change lens holder, accepts 4" diameter lens.

Lens mount is anchored to the center frame by means of three screws and is designed for easy removal and replacement with an horizontal lens mount. Lens mount is of rigid construction so as to accept the longest combination of lens and anamorphic attachment without deflection.

6. REAR SHUTTER. Cast aluminum rear shutter, angle mounted, double blade, revolves at 1440rpm. Rear shutter is designed for maximum freedom from backlash. Shutter blade is easily accessible and adjustable for correct timing.
7. INTERMITTENT. Intermittent is heavy-duty and designed for easy adjustment in the field between star and cam. A heavy 4-point star is used and a VKF sprocket.

Intermittent housing is designed so that it can be mounted by three screws. Housing permits operation in an oil reservoir with oil drain and a visible oil gauge attached. All mechanical parts of intermittent are submerged in oil.

Intermittent sprocket housing has an outboard bearing, easily removable.

Intermittent sprocket is a standard hardened and ground steel sprocket as lightweight as good engineering standards will accept, mounted by a screw and nut.

Intermittent sprocket shaft is spiral cut on mechanism end to mate with framing device.

8. **FRAMING DEVICE.** The framing device consists of a nylon coupling with internal spirals and an external rack for lateral movement. Gear is attached to a shaft running to the front of the projector with a hand knob mounted externally for adjustment. Shaft and knob are designed so as to accept automatic framing device.
9. **LENS FOCUSING DEVICE.** Lens focusing device is a part of the lens mount and it can be removed if necessary for automatic focus device.
10. **CENTER FRAME.** Center frame of projector is made of aluminum, normalized for temperature stability. Placement of sprockets is such that necessary sensors for automation are readily mounted with adequate clearance.

Ballantyne projector is driven by the intermittent and the projector in turn drives the Ballantyne Model VII soundhead and magnetic penthouse.

Top of center frame will accept all standard manufactured penthouse magnetic soundheads, as well as 2000', 3000' and 6000' magazines.

11. **MAIN DRIVE.** Driving mechanism from bottom of projector to soundhead is synchronous belt driven.
12. **FRAMING LAMP.** Framing lamp is mounted so that adequate illumination of entire aperture is obtained. Lamp is of low voltage. No means of switching is provided since it is not in the path of projection light source.
13. **APERTURE COOLING.** Mechanism is designed for air or water cooling. Water circulating plate is a standard supply of projector.
14. **CHANGEOVERS.** Low-voltage solenoid and dower are built into rear shutter mechanism for light changeover and adequate space provided for automation.

Low-voltage transformer is built into mechanism for dower solenoids as well as framing lamp.

INSTALLATION

Each projector is carefully inspected and tested before leaving the factory and unless subjected to particularly severe handling during shipment or installation, should be in perfect operating condition.

The projector has been filled with oil at the factory and unless there are signs of oil having been spilled during shipment, it is not necessary to add any oil.

UNPACKING

The projector has been bolted to the base of the shipping crate. Unscrew bottom of case, set on the two 2 x 4 skids, lift wooden case from projector. Tilt 45° and remove two holding screws.

ACCESSORIES AND TOOLS

The following are furnished with each pair of projectors:

1. 5/32" Allen Wrench
2. 9/64" Allen Wrench
3. 1/4" Allen Wrench
4. 5/16" Allen Wrench
5. 3/16" Allen Wrench
6. 3/32" Allen Wrench
7. 5/64" Allen Wrench
8. 1/8" Allen Wrench
9. Apertures
10. Two Lens Adaptors
11. Six Framing Lamps

MOUNTING

On Ballantyne Model VII Soundhead, mount the Projector on top of the Soundhead. No mounting bars, pans or adaptors are necessary. On the film side of the Projector, line up the three holes in the base plate of the Projector with the three holes in the Soundhead and anchor with 3/8" Allen Screws supplied.

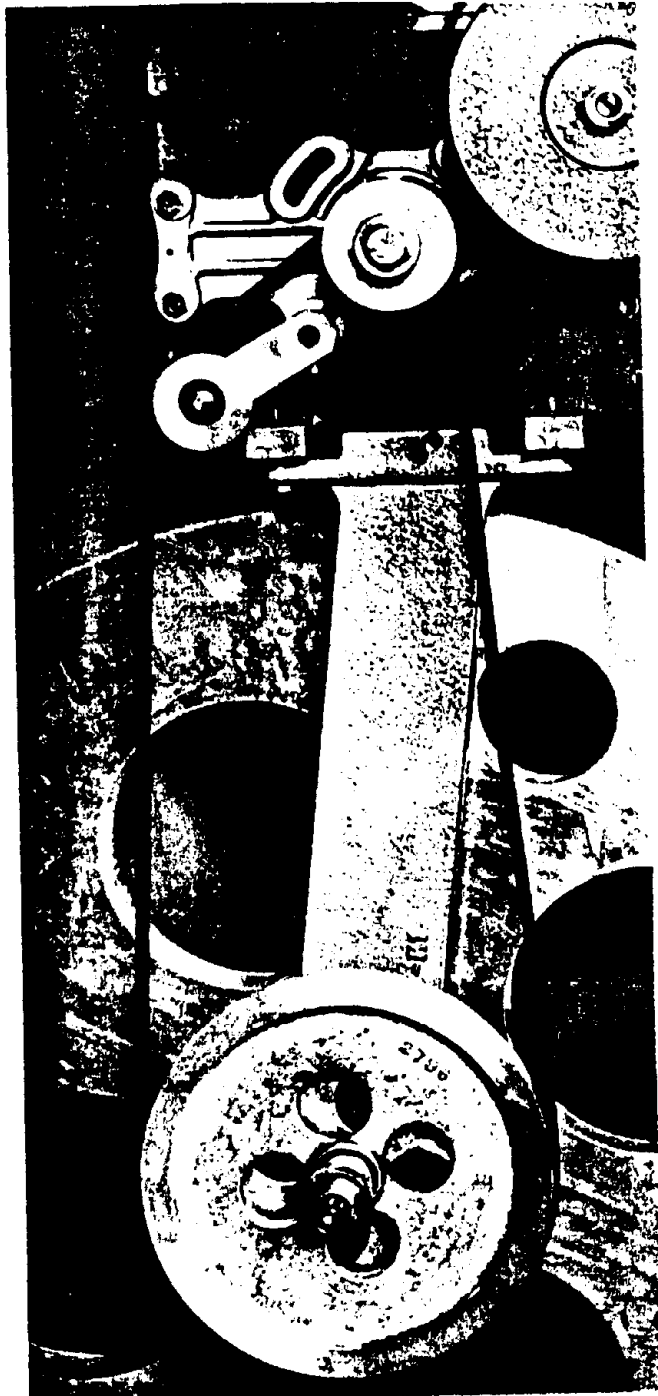

TO INSTALL LENS

1. Each PRO-70 Projector is supplied with two lens adaptors. Insert lens adaptor in lens mount making certain that the pin on the lens adaptor fits into the guided slot in the lens mount. In this position, an Allen set screw will be in direct line with the hole in the lens mount so that lens can be anchored.
2. Focus picture on screen and when using anamorphics, make certain that picture is horizontal as well as in focus. When picture is completely focused, tighten lens anchor screw with Allen wrench supplied.
3. Remove lens and tighten the other three Allen anchoring screws.
4. Repeat this procedure for Wide Screen lens making certain that you do not disturb lens focus knob.
5. From this point on, going from Wide Screen to Cinemascope or reverse, is a simple matter inasmuch as either lens will be in focus as soon as the pin in the lens adaptor fits into the slot of the lens mount.
6. The lens mount should be in a center position when first installing lens.

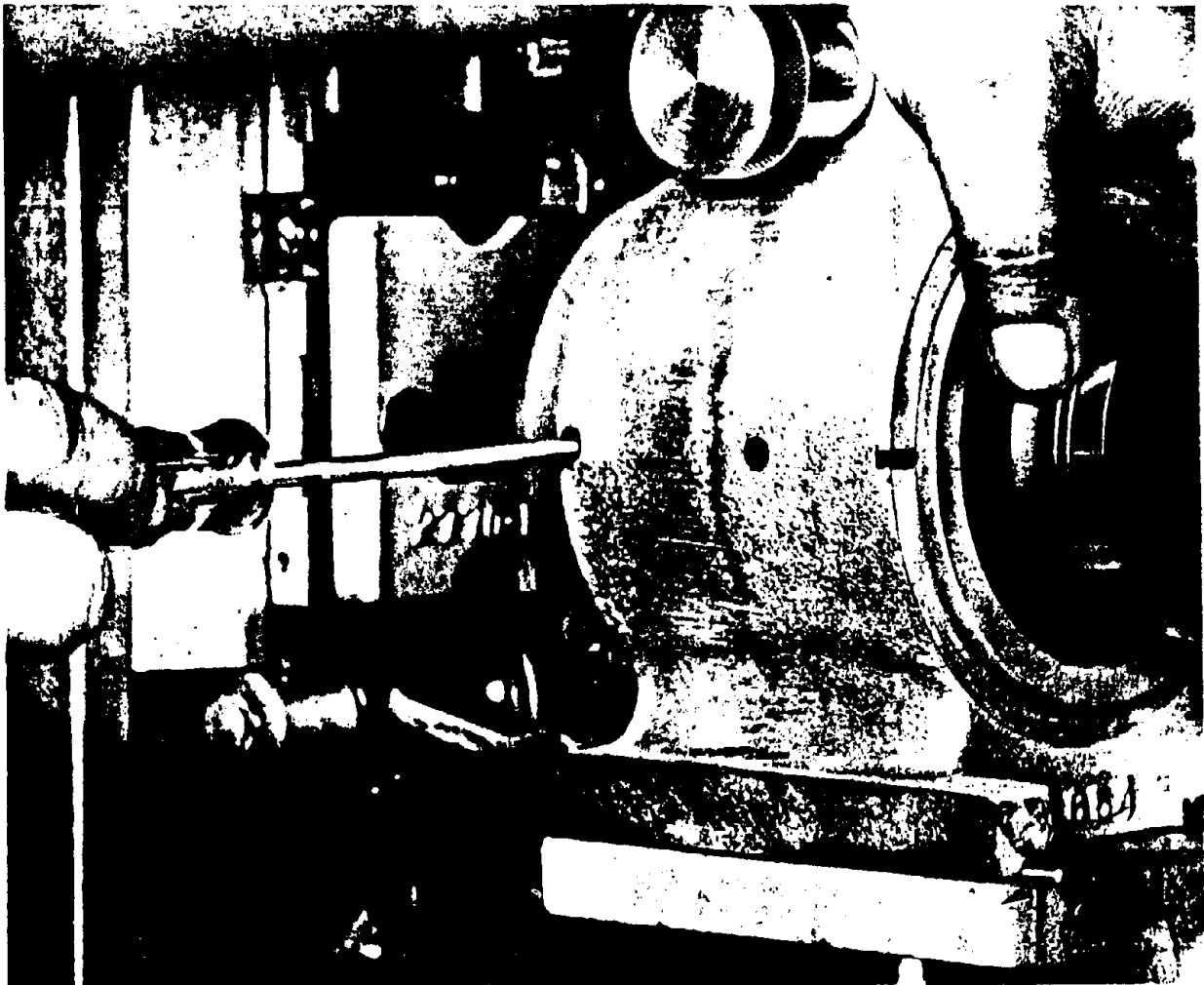

SHUTTER

The shutter blade and framing lamp are accessible through the left door on the film side of the projector. In order to afford maximum protection of anyone accidentally touching a shutter blade, case is designed so that the framing handle must be removed with an Allen Wrench before access can be gained to the shutter compartment. In order to keep shutter blade at a minimum noise level, shutter blade is mounted on an isolation coupling No. 2713. Ample room has been left in the shutter compartment for ease in servicing.

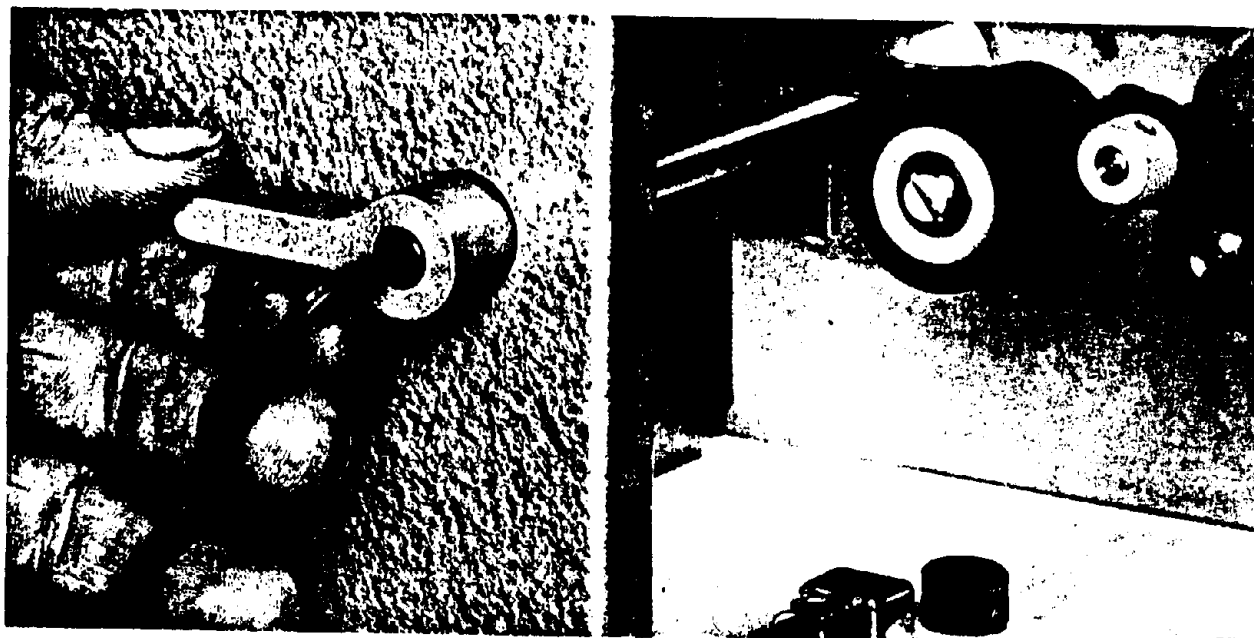

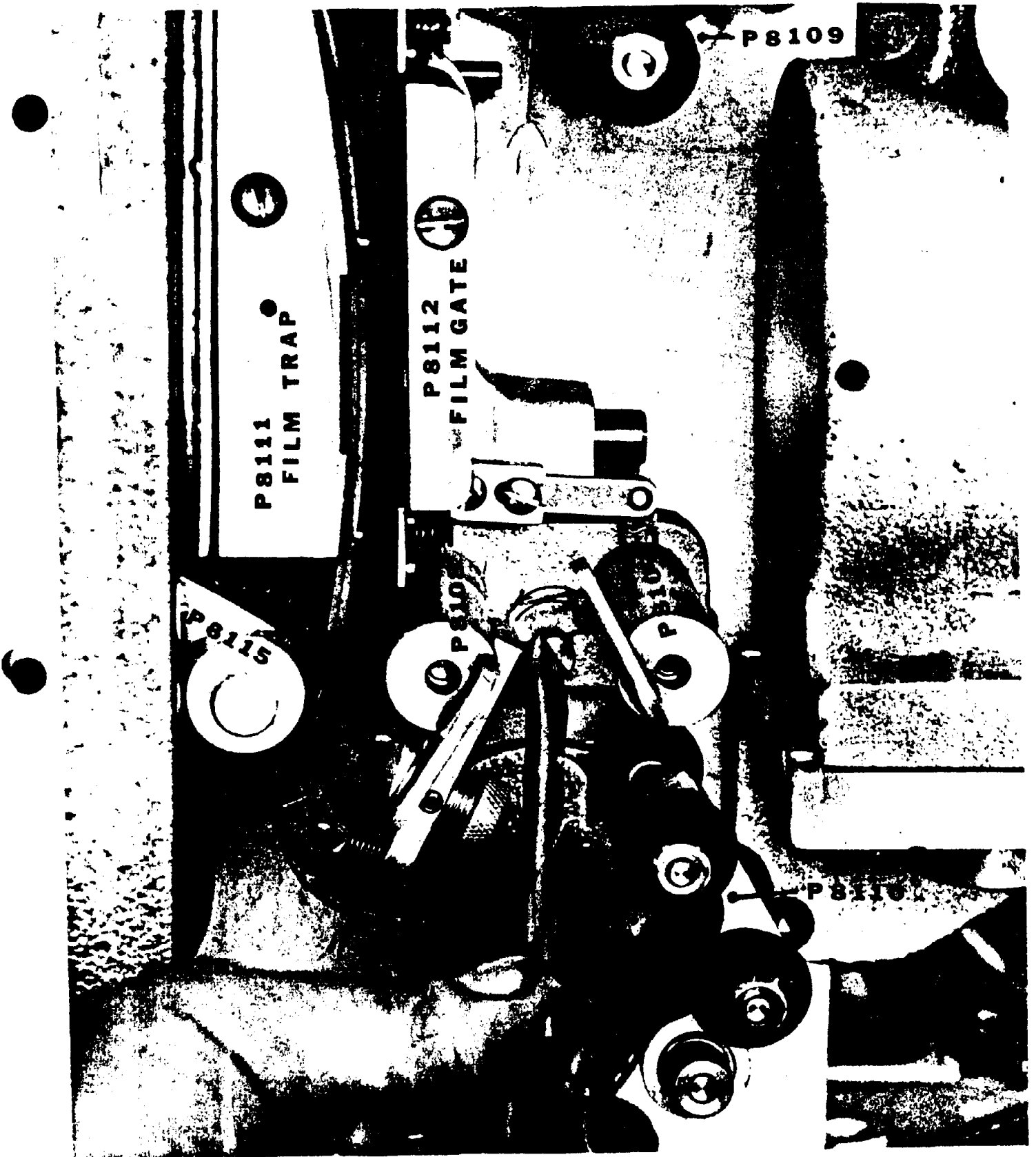

GATE PRESSURE ADJUSTMENT

The Pro 70 is designed to run with minimum pressure. Too much pressure will cause picture jump.

ASSEMBLIES

P 8114 FILM STRIPPER

P 8111 FILM TRAP

P 8109 UPPER PAD ROLLER

P8115 INTERMITTENT SPROCKET

P 8107
GATE OPENING DEVICE

P 8112 FILM GATE

P 8110 LOWER PAD ROLLER

P 8108 INTERMITTENT SHOE

STER

P 8223
70MM SENSOR

P 8113 LOWER FILM GUIDE

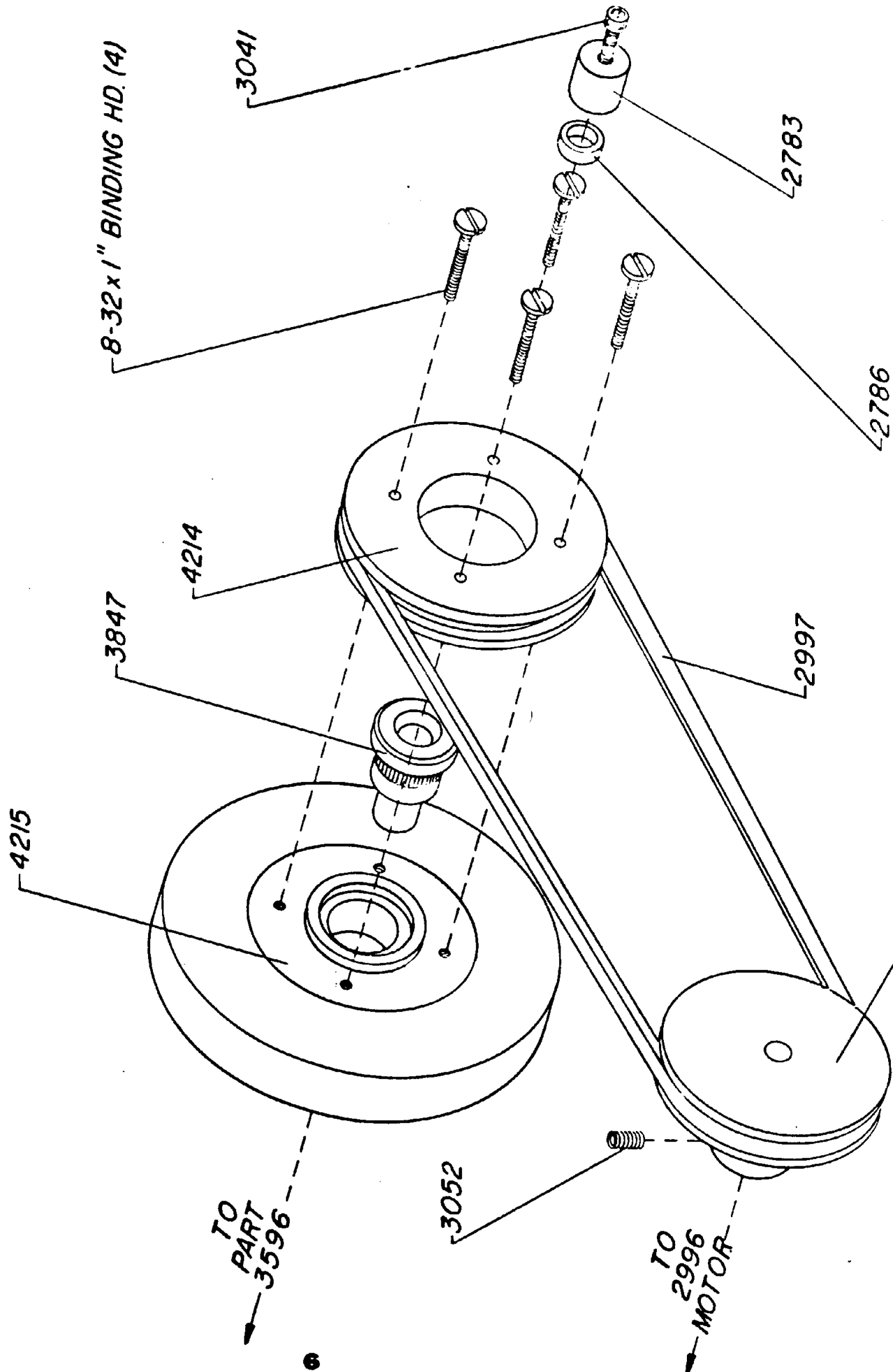

P8014
 INTERMITTENT FLYWHEEL ASSEMBLY

TO
 PART
 3596

TO
 2996
 MOTOR

PROJECTOR INTERMITTENT PULLEY, STANDARD

P8014

<u>PART NO.</u>	<u>DESCRIPTION</u>	<u>AMOUNT USED</u>
3041	10/32 x 3/4 Socket Cap	1
3251H	Flywheel Hub	1
3251	Large Flywheel	1
3252	Flywheel To Motor Pulley	1
2758	Motor Pulley	1
--	8/32 x 1 Bind Head	4

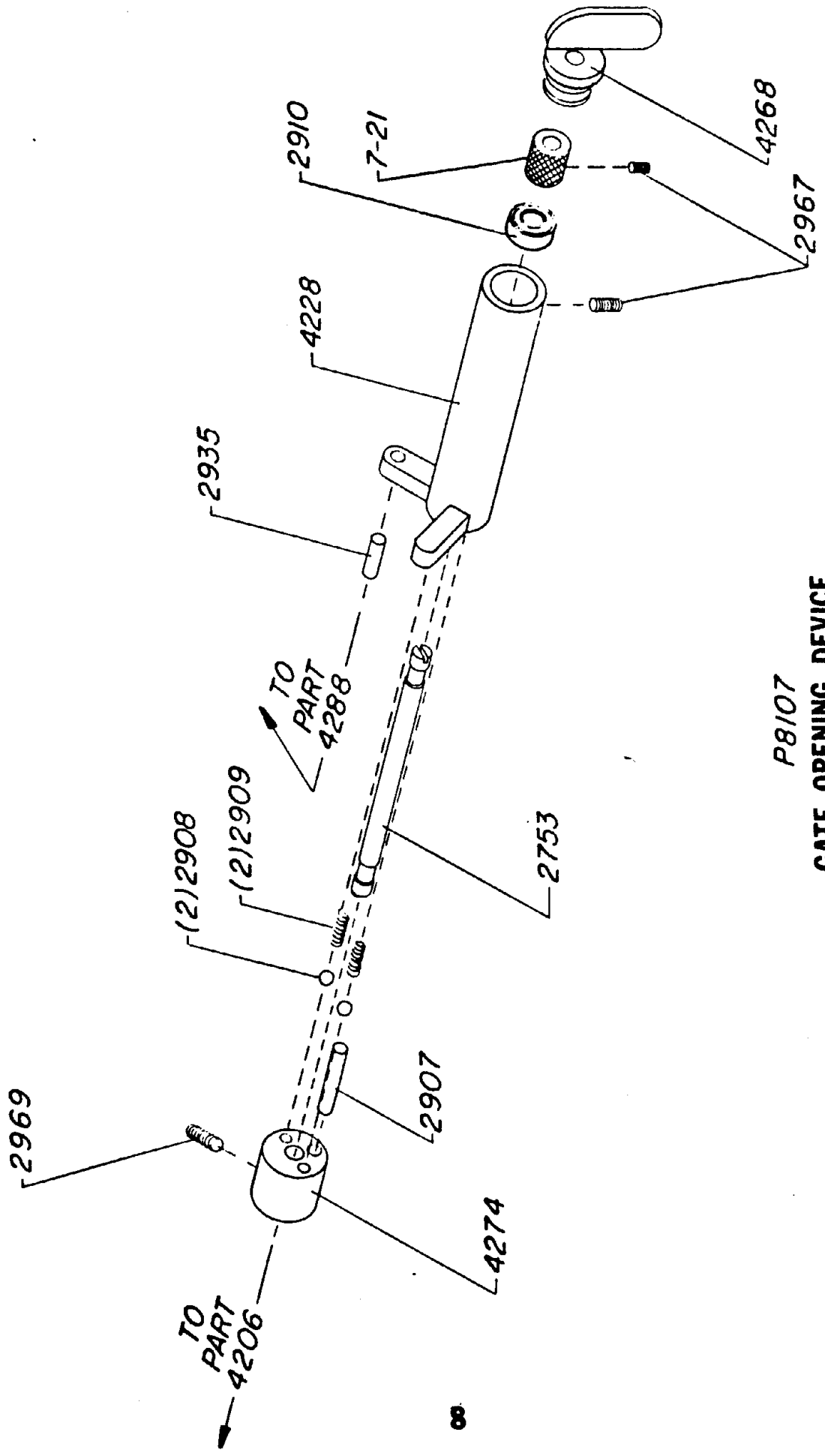

P8107
GATE OPENING DEVICE

70MM GATE OPENING ARM ASSEMBLY

P8107

<u>PART NO.</u>	<u>DESCRIPTION</u>	<u>AMOUNT USED</u>
7-21	Knurled Collar	1
2907	Dowel Pin	1
2908	Steel Ball	2
2909	Spring	2
2910	Bearing	2
2935	Dowel Pin	1
2967	8/32 x 1/8 Socket Set	2
2969	10/32 x 1/4 Socket Set	1
4228	Gate Opening Housing	1
4268	Opening Knob	1
4274	Detent Stud	1
4281	Gate Opening Shaft	1

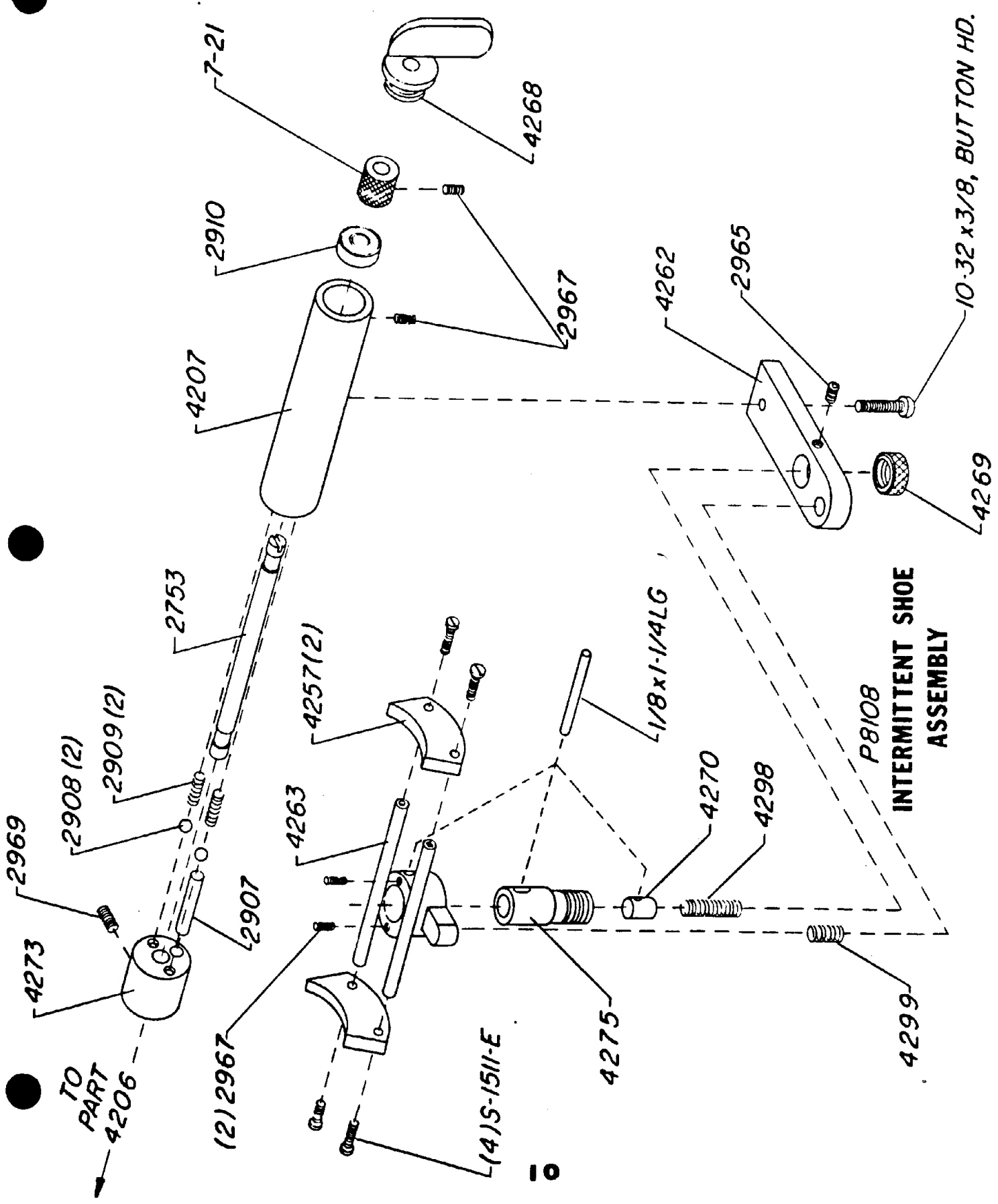

70MM SPIDER SHOE & INTERMITTENT TENSION SHOE ARM

P8108

<u>PART NO.</u>	<u>DESCRIPTION</u>	<u>AMOUNT USED</u>
7-21	Knurled Collar	1
2907	Detent Dowel Pin	1
2908	Steel Ball	2
2909	Spring	2
2910	Bearing	1
2965	10/32 X 3/16 Socket Set	2
2967	8/32 X 1/8 S.S. Socket Set	2
2971	10/32 X 3/8 Button Head	1
S-1511-E	Screws	4
4207	Tension Shoe Opening Cover	1
4257	Intermittent Shoe Delron	2
4262	Tension Shoe Support Arm	1
4263	Tension Shoe Stud Assembly	1
4268	Opening Knob	1
4269	Stud Collar Screw	1
4270	Stud Cap	1
4273P	Detent Stud	1
4275	Tension Shoe Support Stud	1
4281	Shoe Opening Shaft	1
4298	Stud Spring	1
4299	Tension Shoe Rocker Spring	1
4401	1/8 X 1-1/4 Dowel Pin	1

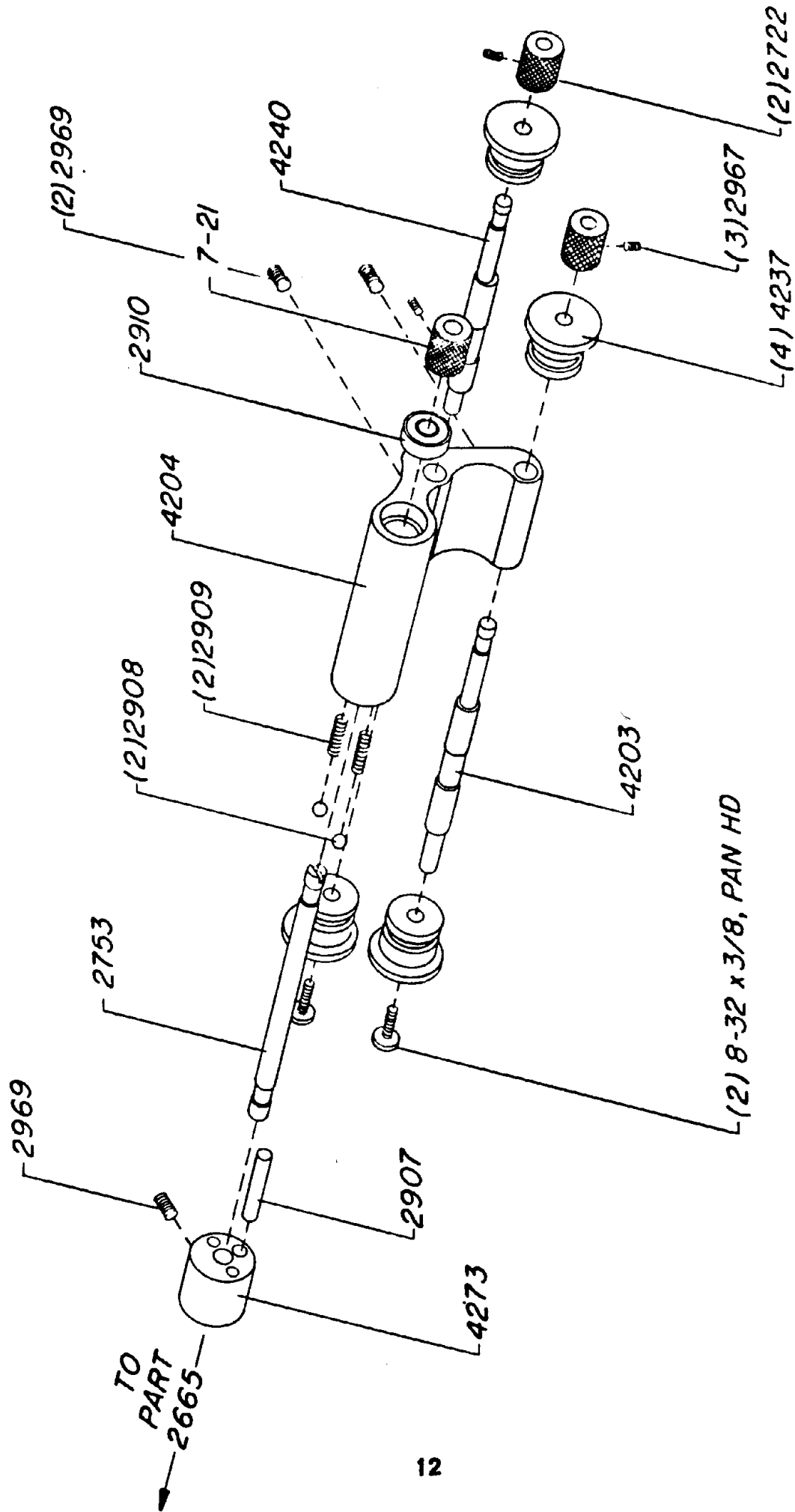

P8109
 UPPER PAD ROLLER ASSEMBLY

70MM UPPER PAD ROLLER ASSEMBLY

P8109

<u>PART NO.</u>	<u>DESCRIPTION</u>	<u>AMOUNT USED</u>
7-21	Knurled Collar	2
2722	Knurled Collar	1
2907	Detent Dowel Pin	1
2908	Steel Ball	2
2909	Spring	2
2910	Bearing	1
2967	8/32 X 1/8 Socket Set	3
2969	10/32 X 1/4 Socket Set	3
4203	Pad Roller Shaft	1
4204-R1	Upper Pad Roller Casting	1
4237	Delron Roller	4
4240	Pad Roller Shaft	1
4281	Shoe Opening Device Shaft	1
	8/32 X 3/8 Pan Head	2

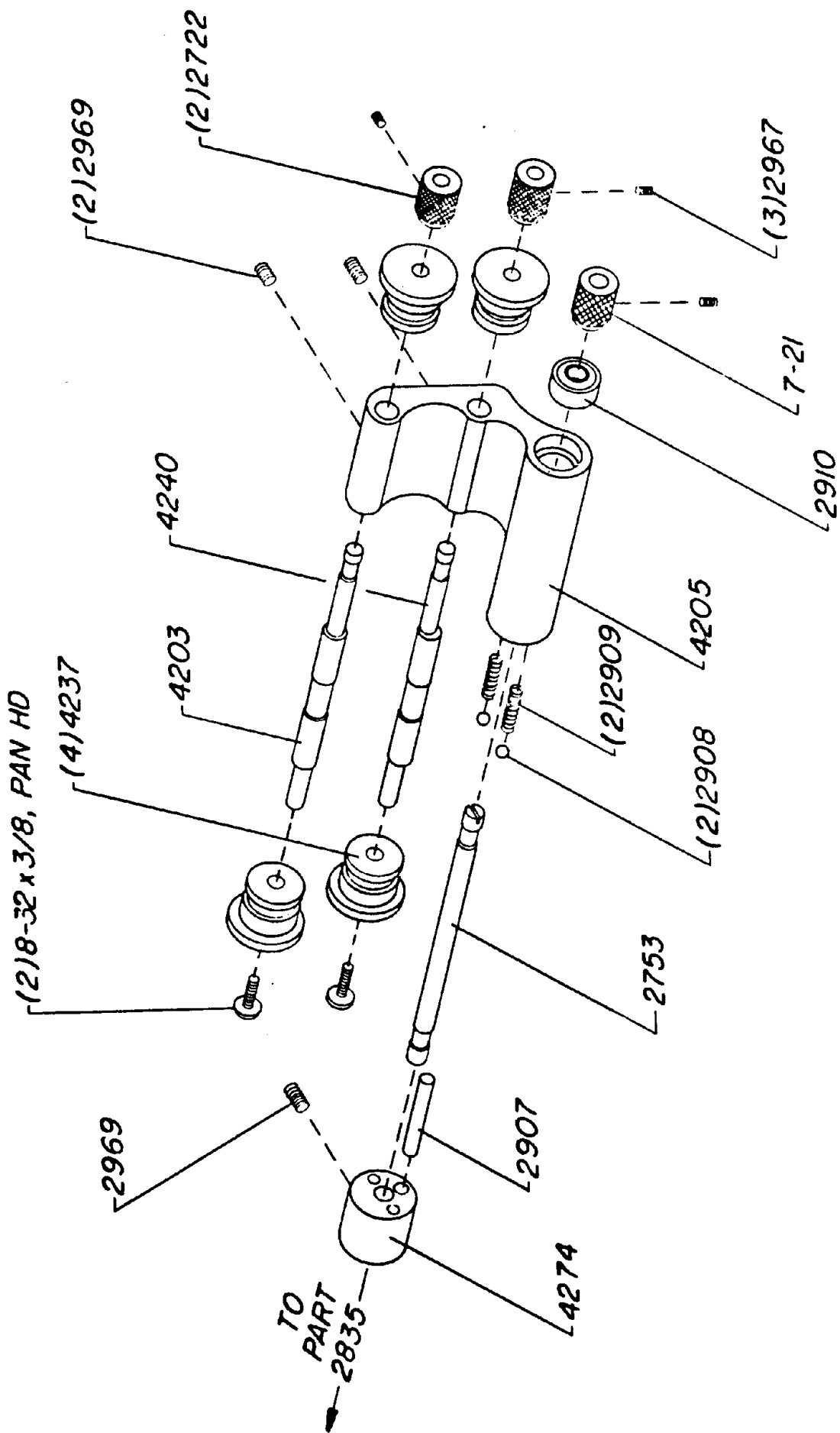

P8110
 LOWER PAD ROLLER ASSEMBLY

70MM LOWER PAD ROLLER ASSEMBLY

P8110

<u>PART NO.</u>	<u>DESCRIPTION</u>	<u>AMOUNT USED</u>
7-21	Knurled Collar	1
2722	Knurled Collar	2
2907	Detent Dowel Pin	1
2908	Steel Ball	2
2909	Spring	2
2910	Bearing	1
2967	8/32 X 1/8 Socket Set	3
2969	10/32 X 1/4 Socket Set	3
4203	Pad Roller Shaft	1
4205R1	Pad Roller Casting	1
4237	Delron Pad Roller	4
4240	Pad Roller Shaft	1
4281	Same As 2753, With Slot On End	1
	8/32 X 3/8 Pan Head	2

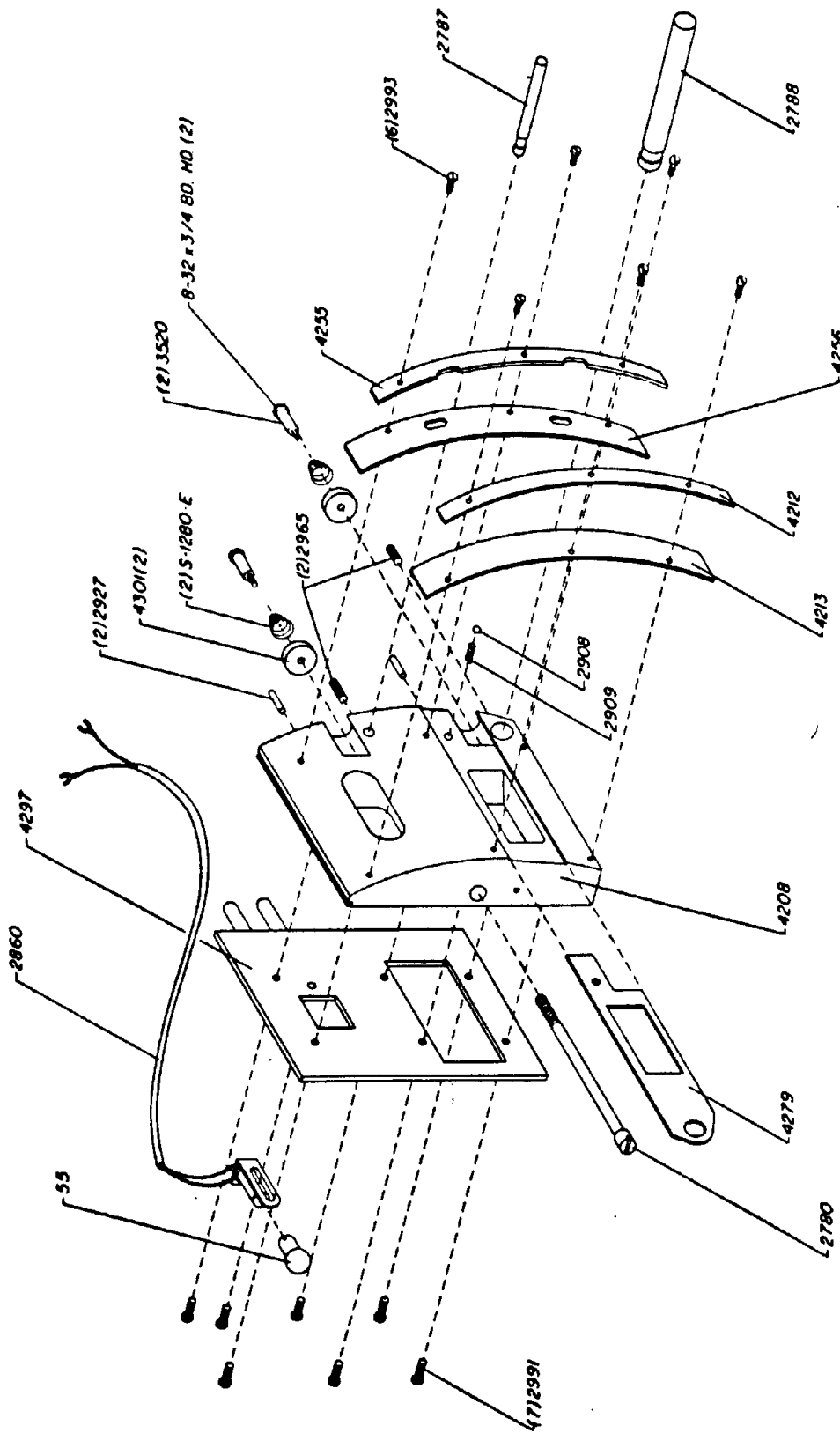

P8111
FILM TRAP PLATE ASSEMBLY

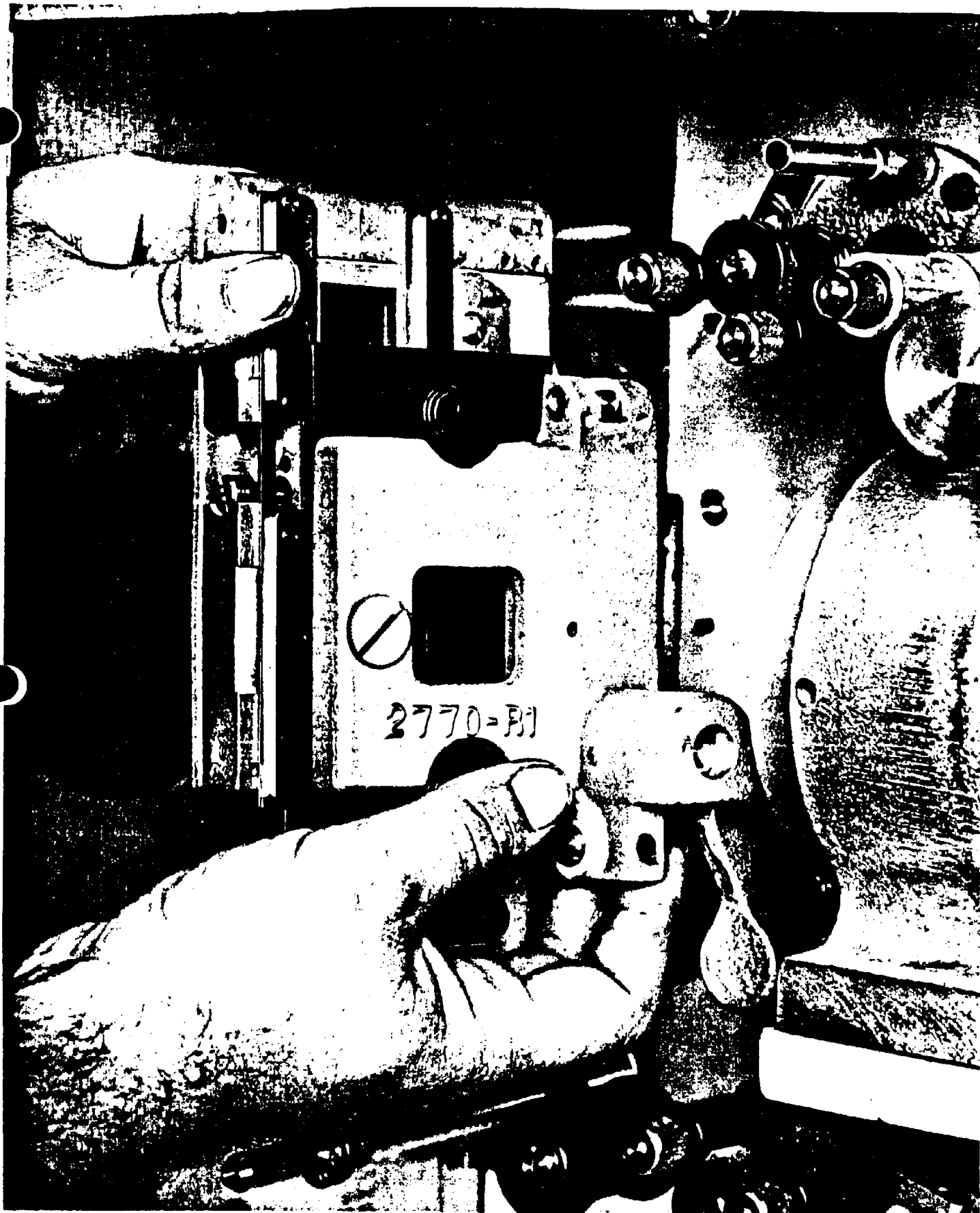

70MM FILM TRAP ASSEMBLY

P8111

<u>PART NO.</u>	<u>DESCRIPTION</u>	<u>AMOUNT USED</u>
2780	Film Trap Mounting Bolt	1
2787	Upper Film Gate Guide Shaft	1
2788	Lower Film Gate Guide Shaft	1
S-1280-E	Conical Compression Spring	2
2860	Threading Lamp Socket & Wire	1
2908	3/16" Steel Ball	1
2909	Spring	1
2927	Pin	2
2965	10/32 X 3/16 Socket Set	2
2991	6/32 X 3/8 Truss Head Screw	7
2993	3/48 X 3/8 Bind Head Screw	8
3520	Spacer & Screw	2
4208	Film Trap	1
4212	Outer Studio Guide	1
4213	Outer Film Trap Shoe	1
4255	Inner Studio Guide	1
4256	Inner Film Trap Shoe	1
4279	Aperture	1
4297	Cooling Plate	1
4301	Film Guide Roller	2
#55	Bulb	1

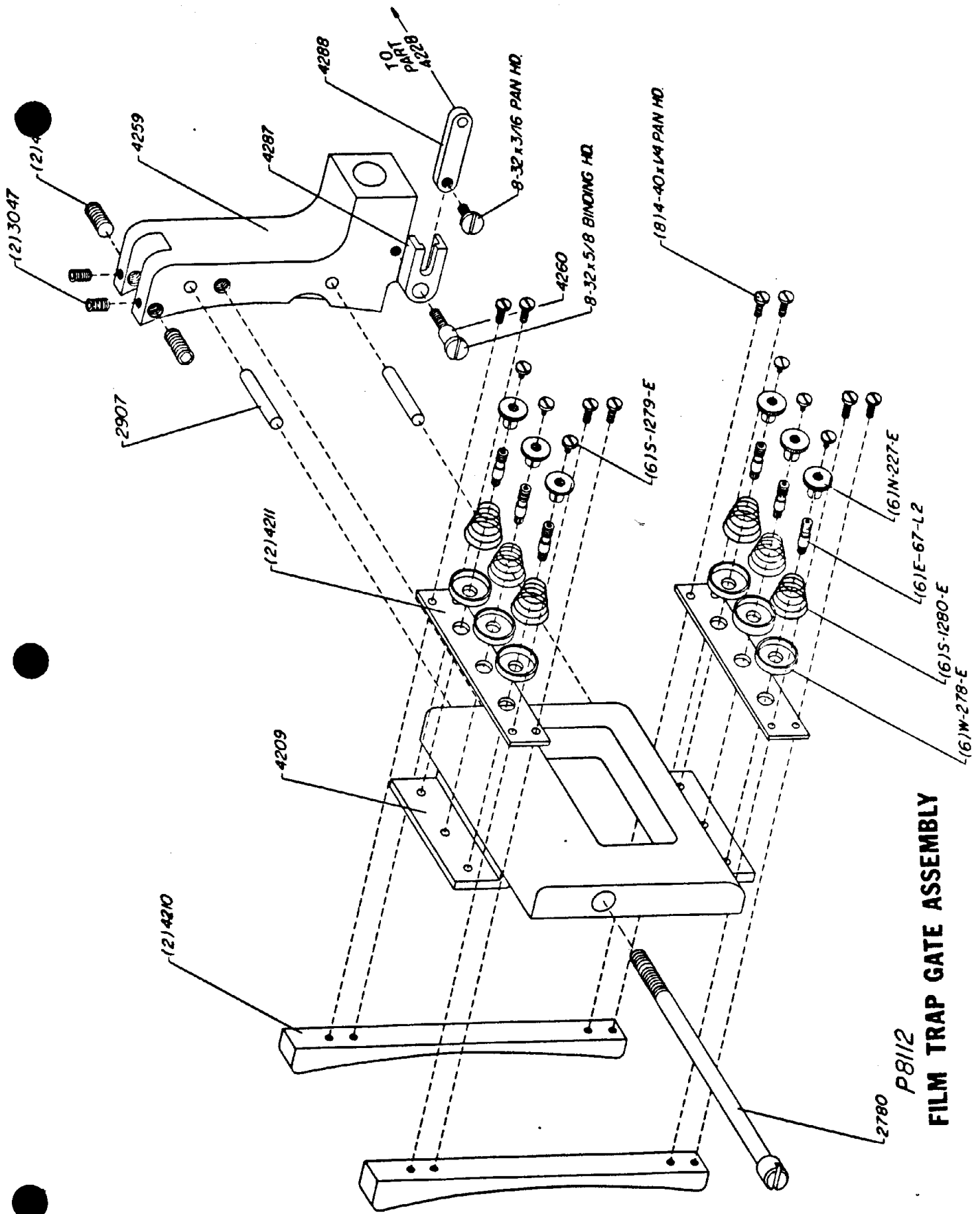

FILM TRAP GATE ASSEMBLY

70MM PRESSURE PAD & GATE ASSEMBLY

P8112

<u>PART NO.</u>	<u>DESCRIPTION</u>	<u>AMOUNT USED</u>
E-67-L2	Stud For Conical Spring	6
N-227-E	Pad Spring Adjusting Nut	6
W-278-E	Spring Pressure Cup Washer	6
S-1279-E	Guide Stud Screw	6
S-1280-E	Conical Compression Spring	6
2780	Gate Mounting Block Screw	1
2907	Dowel Pin	4
3047	Nylon Set Screw	2
4209	Gate Mounting Block	1
4210	Delron Runner	2
4211	Spring Bracket	2
4259	Gate Support Bracket	1
4260	Link Guide Screw	1
4287	Link Guide	1
4288	Detent Link	1
4302	Set Screw	2
	8/32 X 5/8 Bind Head	1
	8/32 X 3/16 Pan Head	1
	4/40 X 1/4 Pan Head	8

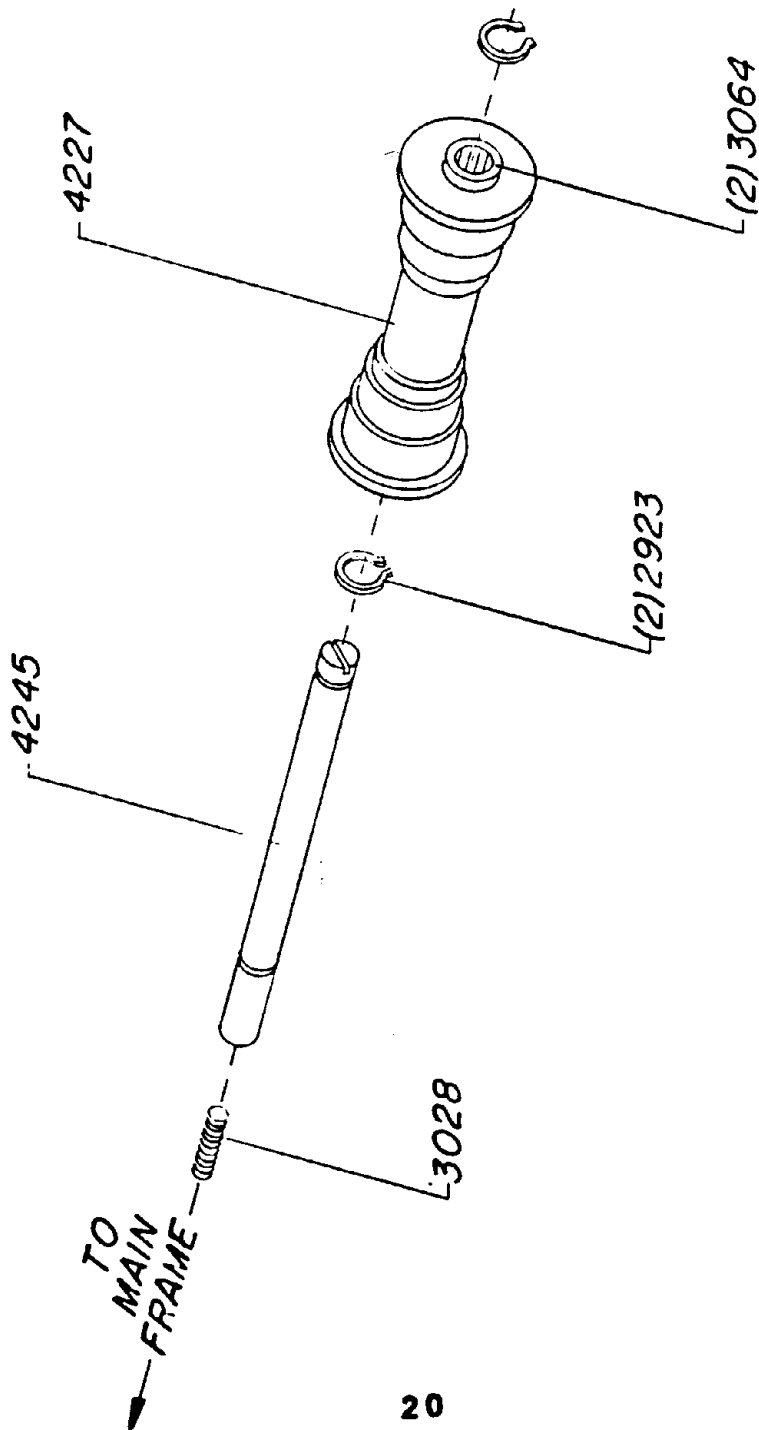

P8113
FILM GUIDE ROLLER ASSEMBLY

70MM INTERMITTENT FILM GUIDE ROLLER ASSEMBLY
P8113

<u>PART NO.</u>	<u>DESCRIPTION</u>	<u>AMOUNT USED</u>
2923	Retaining Ring	
3028	10/32 X 5/8 Socket Set	2
3064	Needle Bearing	1
4227	Film Guide Roller	2
4245	Film Roller Shaft	1
		1

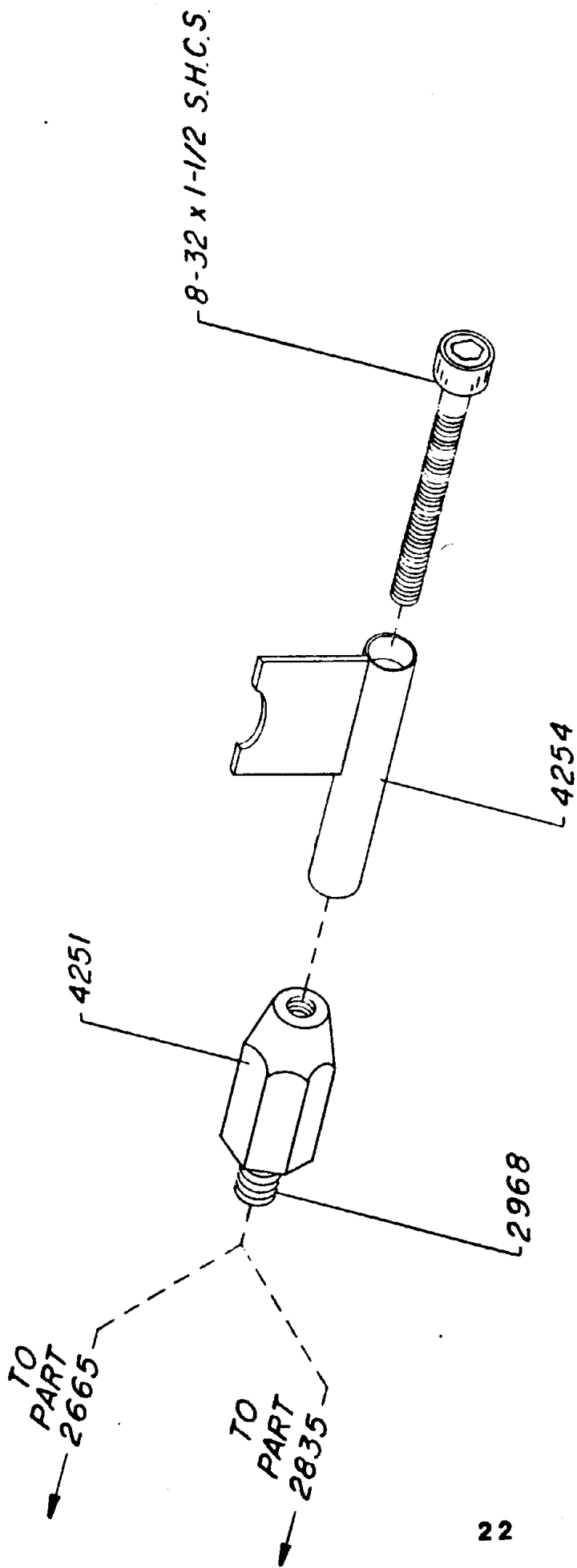

P8114
FILM STRIPPER ASSEMBLY
UPPER & LOWER

70MM FILM STRIPPER

P8114

<u>PART NO.</u>	<u>DESCRIPTION</u>	<u>AMOUNT USED</u>
2968	Stud Screw	1
4251	Hex Stud	1
4254	Stripper Arm	1
	8/32 X 1-1/2 Allen Screw	1

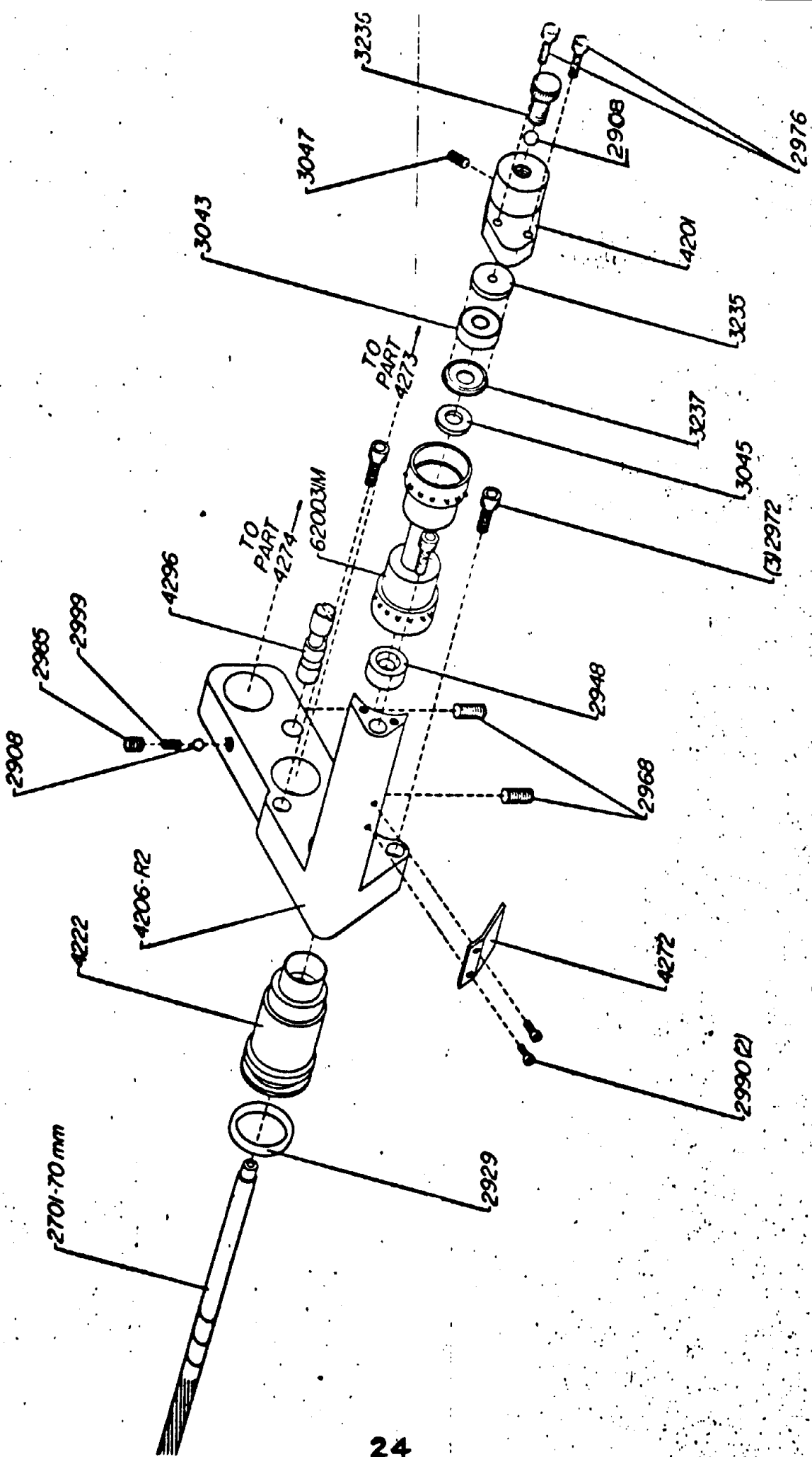

P 8115
 INTERMITTANT
 SPROCKE

70MM OUTBOARD BEARING & SHAFT ASSEMBLY

P8115

<u>PART NO.</u>	<u>DESCRIPTION</u>	<u>AMOUNT USED</u>
2701-70	Intermittent Sprocket Shaft	1
2908	3/16 Steel Ball	2
2929	"O" Ring	1
2948	Oil Seal	1
2968	1/4-20 X 1/2 Socket Set	2
2972	10/32 X 1/2 Socket Cap	3
2976	8/32 X 5/8 Bind Head	2
2985	1/4-20 X 1/4 Socket Set Flat Point	1
2990	4/36 X 1/4 Bind Head	2
2999	1/2 Of 2909 Spring	1
3043	Bearing	1
3045	Felt Pad	1
3047	10/32 X 1/4 Nylon Socket Set	1
3235	Outboard Bearing Adjustment Washer	1
3236	Outboard Bearing Adjustment	1
3237	Outboard Bearing Bushing	1
4201	Outboard Bearing Bracket	1
4206-R1	Intermittent Sprocket Bracket	1
4222	Intermittent Sprocket Shaft Bushing	1
4272	Intermittent Film Stripper	1
4296	Eccentric Gate Stop	1
62031M	Intermittent Sprocket	1

PRO 70 PROJECTOR PARTS

<u>PART NO</u>	<u>DESCRIPTION</u>
2650	BOTTOM PLATE
2651	MAIN FRAME
2653	LENS MOUNT
2653R-1	LENS MOUNT (FOCUS)
2654	LENS HOLDER
2660	INTERMITTENT BASE PLATE
2661	INTERMITTENT COVER
2665R1	UPPER HORIZONTAL SHAFT & PAD ROLLER HOUSING
2667	LENS ADAPTOR
2668	LENS LOCK RING 4" DIAMETER
2676	FRAMING SHAFT BUSHING
2678	FRAMING COUPLER HOUSING (NOT SOLD SEPARATELY)
2680	INTERMITTENT CAM SHAFT BUSHING (SOLD ONLY WITH 3596)
2681	INTERMITTENT STAR SHAFT BUSHING
2682	INTERMITTENT COUPLER INSERT (NOT SOLD SEPARATELY)
2690	INTERMITTENT SPROCKET SHAFT BUSHING
2701-70	INTERMITTENT SPROCKET SHAFT
2708	PLASTIC FRAMING COUPLER & BOBBIN (REPLACED BY 3305)
2709	FRAMING COUPLING PLUG (NOT SOLD SEPARATELY)
2712	HORIZONTAL DRIVE SHAFT CAP (BACK)
2715	HORIZONTAL SHAFT (NOT SOLD SEPARATELY)
2716	VERTICAL SHAFT
2717N	NYLON GEAR (NOT SOLD SEPARATELY)
2715/2717N	HORIZONTAL SHAFT & GEAR
2719	CAM SHAFT GEAR
2720	SHUTTER SHAFT HOUSING
2721	KNURLED COLLAR 1/4"
2722	KNURLED COLLAR 7/32"
2725	STOP PIN
2727	FRAMING SHAFT CAP (BACK)
2728	FRAMING SHAFT CAP (FRONT)
2733	FRAMING GEAR
2735R1	FRAMING SHAFT (HORIZONTAL)
2743R	FRAMING SHAFT (VERTICAL)
2744	VERTICAL SHAFT CAP (TOP)
2745	VERTICAL SHAFT CAP (BOTTOM)
2746	FRAMING SHAFT CAP (BOTTOM)
2749	TOP PLATE
2750	CAM BEARING LOCKING WASHER
2751	NYLON TENSION PLUG
2752N	LOCK NUT
2752S	ADJUSTMENT SCREW
2753	PAD ROLLER ARM SHAFT
2754R1	SHUTTER SHAFT
2757	SHUTTER SHAFT SPACER

PRO 70 PROJECTOR PARTS

<u>PART NO</u>	<u>DESCRIPTION</u>
2758	MOTOR PULLEY
2761A	UPPER & LOWER MAGAZINE ROLLER
2763	SHUTTER CAP GASKET
2765R1	CO-FS BLADE
2767	FOCUS BRACKET
2768N	SHUTTER SHAFT GEAR
2771	LENS SLIDE RODS
2772	LENS MOUNT STUD
2773	LENS MICRO FOCUS SCREW
2775	LENS DRAG WASHER
2776R	LENS MOUNT STUD WASHER
2777	FOCUS BEARING SPACER
2778	LENS CLAMP SHAFT
2780	FILM TRAP MOUNTING BOLT
2782	LENS ADAPTOR PRESSURE RING
2783	INTERMITTENT & SHUTTER SHAFT CAP
2786R	FLYWHEEL BRASS WASHER
2788	LOWER FILM GATE PLATE SHAFT
2795	FRICTION DISC
2796	V-BELT TAKE-UP PULLEY
2797	UPPER ARM
2801	CONNECTING PIN
2802	SOLENOID CONNECTING ARM
2803	SOLENOID MOUNTING BRACKET
2804	SOLENOID BRACKET SPACER 1/4"
2805	SOLENOID BRACKET SPACER 7/16"
2806	FRAMING KNOB
2807R	LENS HOLDER KNOB
2808	LENS MOUNT KNOB
2810	TAKE-UP SPRING BUSHING
2811	TAKE-UP TENSION KNOB (UPPER & LOWER)
2812	GILMER TIMING BELT DRIVE (PRO-35)
2814	PAD ROLLER DETENT ADJ. SCREW
2815	VERTICAL & FRAMING CAP LOCK SCREW
2821	DRAIN BLOCK
2822	DRAIN BLOCK BUSHING
2823	DRAIN PIPE
2825	UPPER REEL HOLDBACK CLUTCH
2826	UPPER FRICTION DISC
2829	GILMER PULLEY
2835	LOWER HORIZONTAL SHAFT & PAD ROLLER HOUSING
2838	DELRON STAR BUSHING
2839	UPPER FRICTION DISC KEY
2847	TEFLON STOP PIN
2851	INTERMEDIATE ROLLER SHAFT

PRO 70 PROJECTOR PARTS

<u>PART NO</u>	<u>DESCRIPTION</u>
2853	SHEAVE IDLER PULLEY (FOR OTHER MFG PROJ)
2857	HORIZONTAL FRAMING SHAFT FLANGE
2860	FRAMING LIGHT MOUNT ASSEMBLY
2887	HORIZONTAL CAP BUSHING
2892	UPPER HORIZONTAL SHAFT CAP
2900	"O" RING (622727)
2901	BEARING (201-S)
2903	PRESSURE WASHER (F-1240-010)
2904	"O" RING (623002)
2905	BEARING (202-S)
2907	IDLER DETENT DOWEL PIN (3/16" X 7/8" PIN)
2908	STEEL BALL (3/16" BALL)
2909	SPRING (.515 LONG)
2910	BEARING (R-4 FFP)
2912	PRESSURE WASHER (F1164-009)
2913	BEARING (200-S)
2914	KEY (#204 WOODRUFF)
2915	RETAINING RING (5160-47)
2917	RETAINING RING (5100-66)
2918	COTTER PIN
2919	ROATRY SOLENOID (35241-033, SIZE 4E)
2920	BEARING (R-6)
2921	"O" RING (622719)
2922	"O" RING (622707)
2923	RETAINING RING (5100-37)
2924A	RETAINING RING (N-5000-87)
2925A	WASHER (18816)
2926	BEARING (R-6FF)
2927	ROLL PIN (1/8" X 1/2")
2929	"O" RING (622718)
2931	RETAINING RING (N-5001-87)
2932	RETAINING RING (5101-37)
2935	DETENT DOWEL PIN (3/16" X 5/8")
2936	INCHING KNOB (125-SS)
2937	TIMING BELT (260XL075 - 30120XC/4)
2938	OIL CUP (#1301 GITS)
2940	"O" RING (622747)
2941	STEEL BALL 1/4" (#108 F.C.)
2942	RETAINING RING (N-5001-125)
2942R	NAMEPLATE
2943	NYLON TUBE (F.C. #1)
2944	BARB (#PGH 4-2)
2945	STOP NUT (29NE-054)
2948	OIL SEAL (3101) C/R
2949	OIL SEAL (3723) C/R

PRO 70 PROJECTOR PARTS

<u>PART NO</u>	<u>DESCRIPTION</u>
2950	OIL SEAL (92X9508)
2951	OIL SEAL (4641) C/R
2952	OIL SEAL (5618) C/R
2954	HEX NUT (1/4-28 HEX NUT)
2955	BEARING (R-8FFM) (ALSO USED MODEL 7)
2956	RETAINING RING (N-5000-112)
2957	TAKE-UP SPRING (44683-H)
2964	SET SCREW (5/16-18 X 1/2")
2965	SET SCREW (10-32 X 3/16")
2966	SET SCREW (10-32 X 1/8")
2967	SET SCREW (8-32 X 1/8")
2968	SET SCREW (1/4-20 X 1/2")
2969	SET SCREW (10-32 X 1/4")
2970	SET SCREW (1/4-20 X 1/4")
2971	BUTTON HEAD SCREW (10-32 X 1/2")
2972	CAP SCREW (10-32 X 1/2")
2973	CAP SCREW (10-32 X 5/8")
2974	CAP SCREW (8-32 X 5/8")
2975	CAP SCREW (10-32 X 1")
2976	CAP SCREW (8-32 X 1/2")
2977	CAP SCREW (1/4-20 X 1")
2978	CAP SCREW (5/16-18 X 3/4")
2979	CAP SCREW (5/16-18 X 1")
2980	ALLEN FLAT HEAD SCREW (1/4-20 X 1/2")
2983	CAP SCREW (10-32 X 1-1/2")
2985	SET SCREW (1/4-20 X 1/4" FLAT POINT)
2987	ROLL PIN (3/32" X 5/16")
2990	SCREW (4-36 X 1/4" FIL. HD.)
2991	SCREW (6-32 X 3/8" TRUSS HD. S.S.)
2993	SCREW 3-48 X 3/8" BD. HD.)
2994	MOUNTING BOLT (1/4-20 X 5/8" HEX HD.)
2995	WASHER (11/16 O.D. X 1/4" HOLE X 1/16" THICK)
2996	MOTOR (TYPE NS1-34)
2999	SPRING (.250 LONG) (HALF OF #2909)
3001	CAP SCREW (8-32 X 7/8")
3004	ROLL PIN (3/32" X 9/16")
3006	LOCK WASHER (3/8")
3007W	WASHER
3008	LOCK WASHER (#10)
3025	NAMEPLATE (TAKE-UP ARMS)
3027	SOCKET CAP SCREW (1/4-20 X 3/4")
3028	SET SCREW (10-32 X 5/8")
3041	CAP SCREW (10-32 X 3/4")
3043	BEARING (R-4-A-4)
3045	FELT WASHER (INTERMITTENT SPROCKET ASSEMBLY)

PRO 70 PROJECTOR PARTS

<u>PART NO</u>	<u>DESCRIPTION</u>
3047	NYLON SET SCREW (10-32 X 5/16")
3048	CAPACITOR (CSP-161)
3052	SET SCREW (1/4-20 X 3/8")
3059	NICE BEARING (5491)
3064	B-66 NEEDLE BEARING
3075	ROLL PIN (1/8" X 3/4")
3205	SOUNDHEAD PULLEY
3232	OIL LEVEL RING
3235	OUTBOARD BEARING ADJUSTMENT WASHER
3236	OUTBOARD BEARING ADJUSTMENT
3237	OUTBOARD BEARING BUSHING
3238	REEL SHAFT COLLAR (1/2")
3239	TAKE-UP SHAFT (1/2") (REVERSE & REWIND)
3240	TAKE-UP SHAFT (1/2") (STANDARD)
3244	REEL LOCK (1/2" TAKE-UP SHAFT)
3245	BELT TIGHTENER IDLER ARM
3249	REEL SHAFT COLLAR PIN (1/2" SHAFT)
3250A	INT. COVER BUSHING (FOR NEW 3086)
3251	INT. FLYWHEEL & 3251R1
3252	PULLEY
3261	SHUTTER SHAFT ECCENTRIC BACK BUSHING (NEW)
3262	V-BELT LOWER TAKE-UP PULLEY (CENTURY)
3264	PRO-35 MOTOR MOUNT BRACKET
3264GE	MOTOR CRADLE
3520	SPACER
3596	CAM & SHAFT, INCLUDES 2680 BUSHING
3847	INTERMITTENT FLYWHEEL HUB
4201	OUTBOARD BEARING BRACKET
4202	PAD ROLLER
4203	PAD ROLLER SHAFT
4204	UPPER PAD ROLLER CASTING
4205	LOWER PAD ROLLER CASTING
4206	INTERMITTENT SPROCKET BRACKET
4207	TENSION SHOE OPENING COVER
4208	FILM TRAP
4209	GATE MOUNTING BLOCK
4210	DELRON RUNNER
4211	SPRING MOUNTING BRACKET
4212	OUTER STUDIO GUIDE
4213	OUTER FILM TRAP SHOE
4214	FLYWHEEL
4215	SYNC MOTOR FLYWHEEL
4219	TAKE-UP SHAFT
4220	COUPLER BOBBIN
4222	INTERMITTENT SPROCKET SHAFT BUSHING

PRO 70 PROJECTOR PARTS

<u>PART NO</u>	<u>DESCRIPTION</u>
4225	SPACER
4226	DELRON ROLLER
4227	FILM GUIDE ROLLER
4228	GATE OPENING
4237	DELRON ROLLER
4240	PAD ROLLER SHAFT
4245	FILM ROLLER SHAFT
4251	HEX STRIPPER STUD
4254	FILM STRIPPER
4255	INNER STUDIO GUIDE
4256	INNER FILM TRAP SHOE
4257	INTERMITTENT SHOE DELRON
4259	GATE SUPPORT BRACKET
4260	LINK GUIDE SCREW
4262	TENSION SHOE SUPPORT ARM
4263	TENSION SHOE STUD
4268	OPENING KNOB
4269	STUD COLLAR SCREW
4270	STUD CAP
4271	SHUTTER BLADE
4272	INTERMITTENT FILM STRIPPER
4273P	DETENT STUD
4274	DETENT STUD
4275	TENSION SHOE SUPPORT STUD
4279	APERTURE PLATE
4281	GATE OPENING SHAFT
4287	LINK GUIDE
4288	DETENT LINK
4296	ECCENTRIC GATE STOP
4297	TRAP COOLING PLATE
4298	STUD SPRING
4299	TENSION SHOE ROCKER SPRING
4301	FILM GUIDE ROLLER
4302	SET SCREW

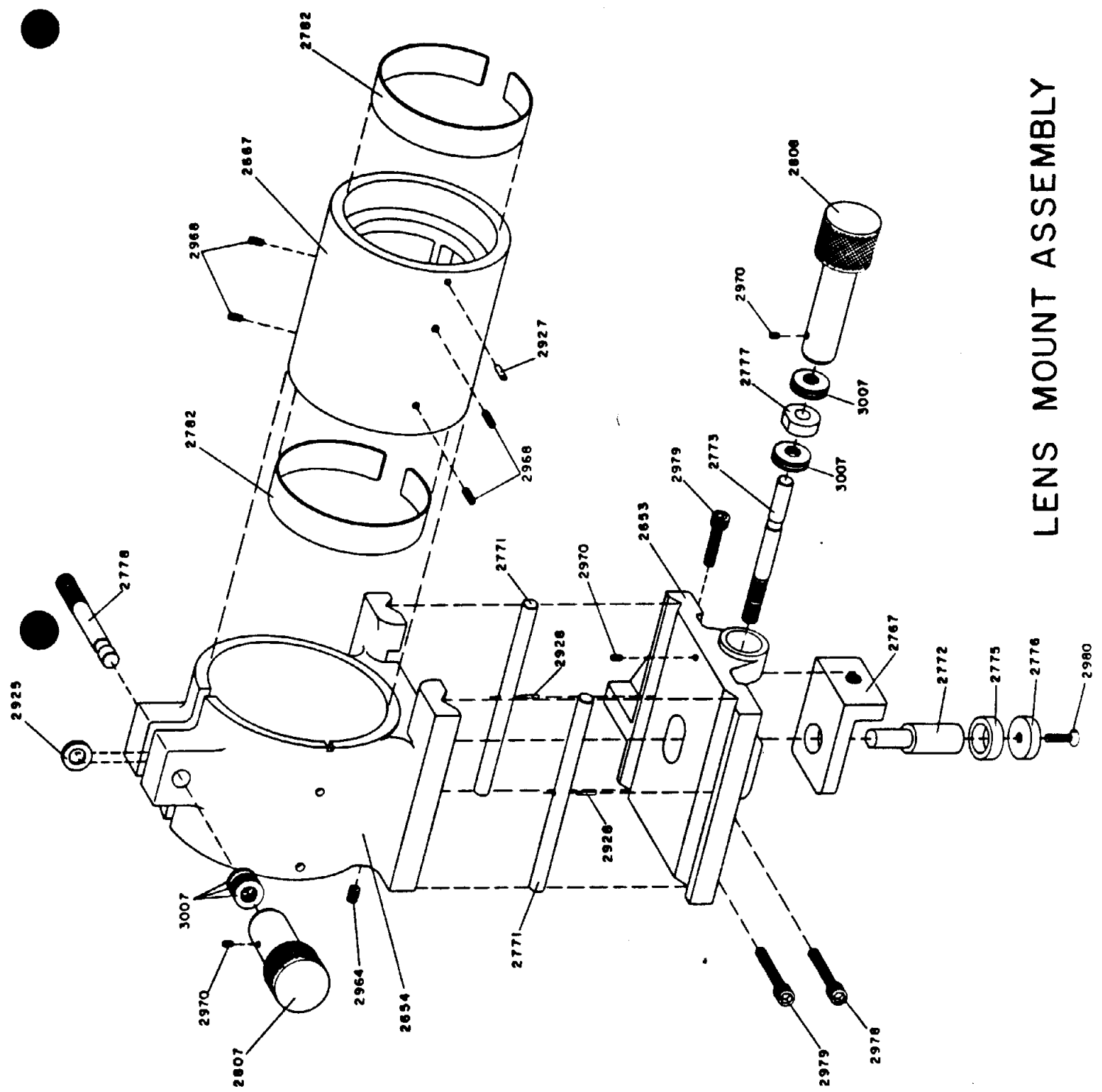

LENS MOUNT ASSEMBLY

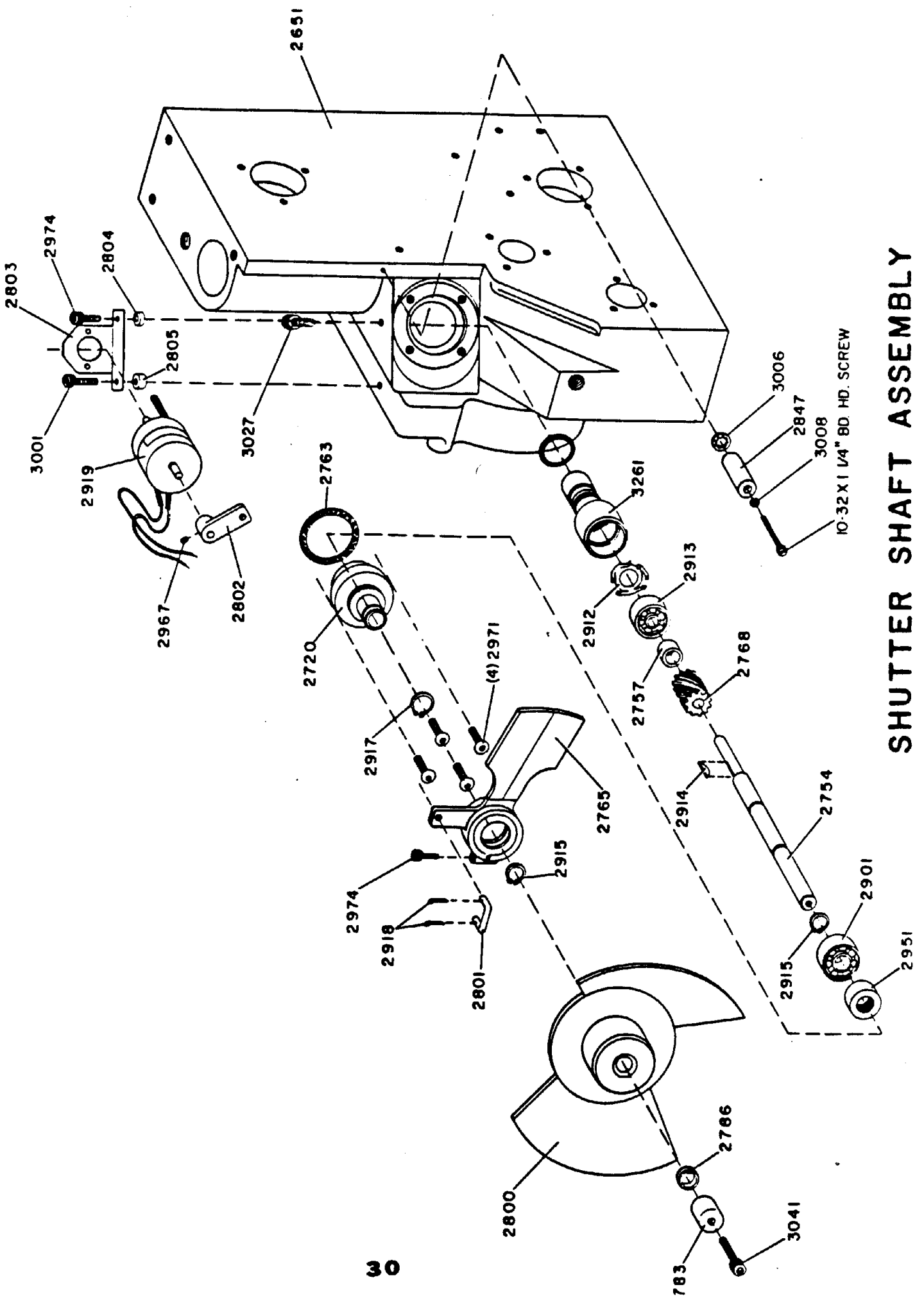

SHUTTER SHAFT ASSEMBLY

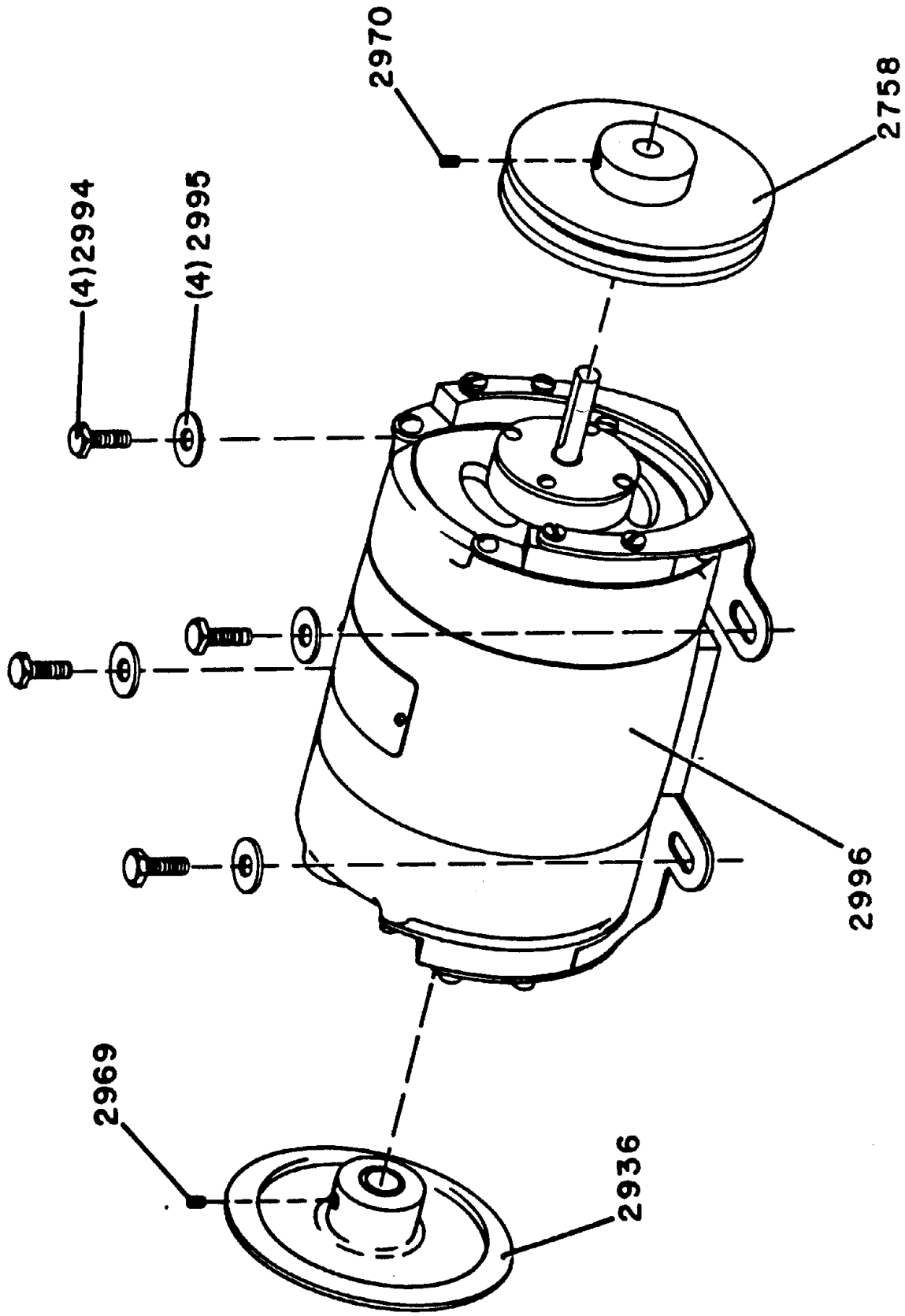

MOTOR ASSEMBLY

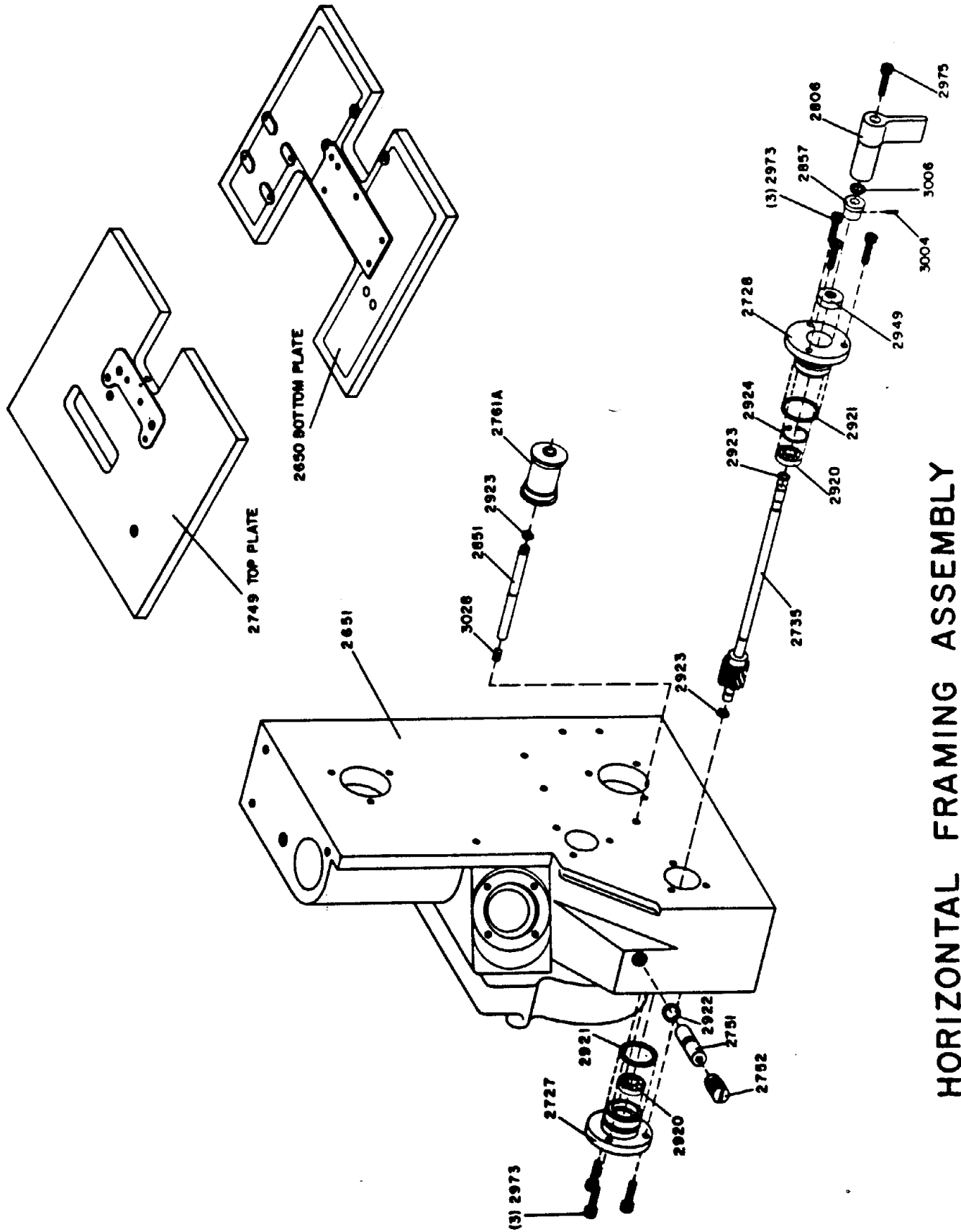

HORIZONTAL FRAMING ASSEMBLY

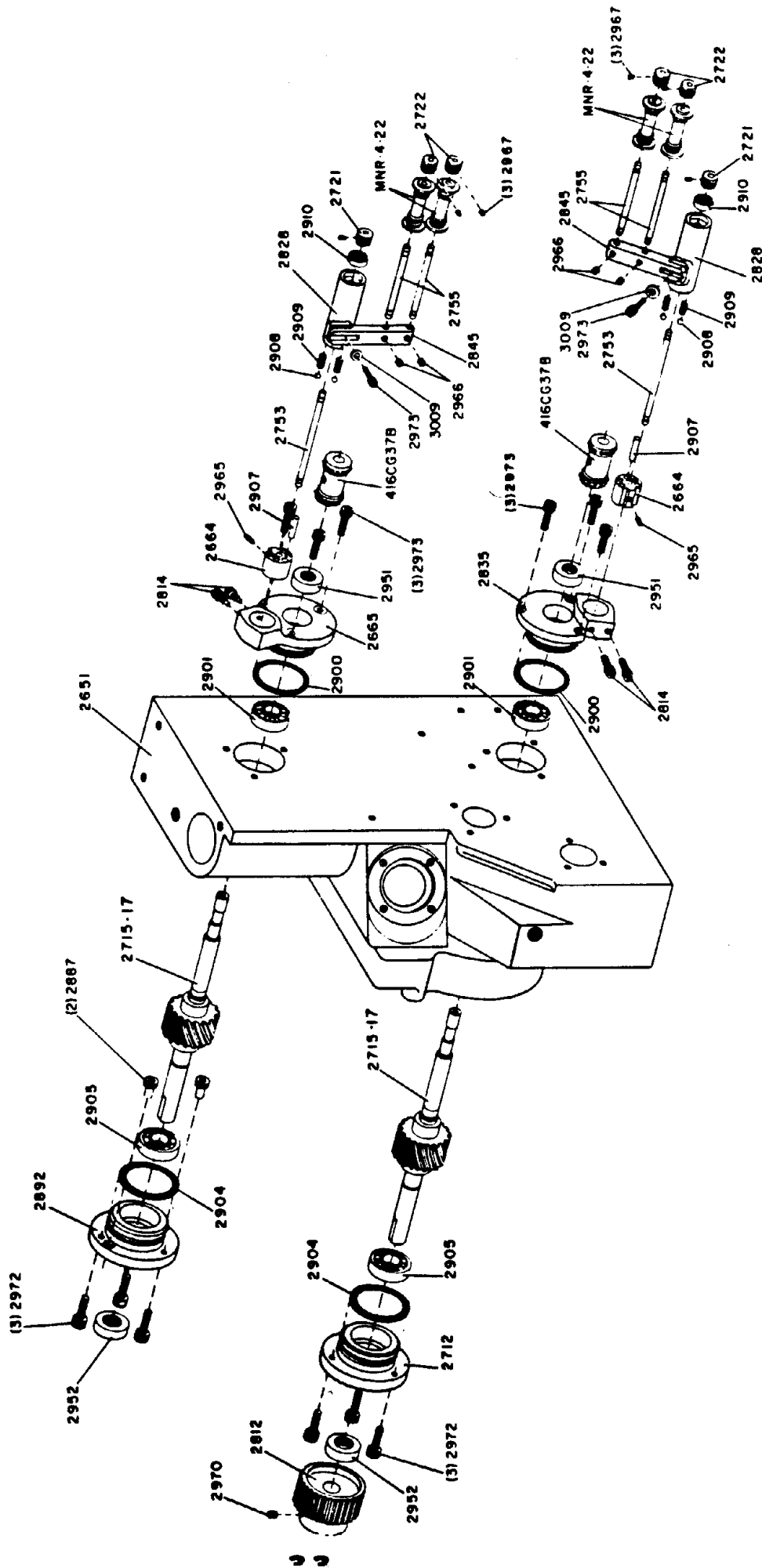

HORIZONTAL UPPER & LOWER SHAFT ASSEMBLY

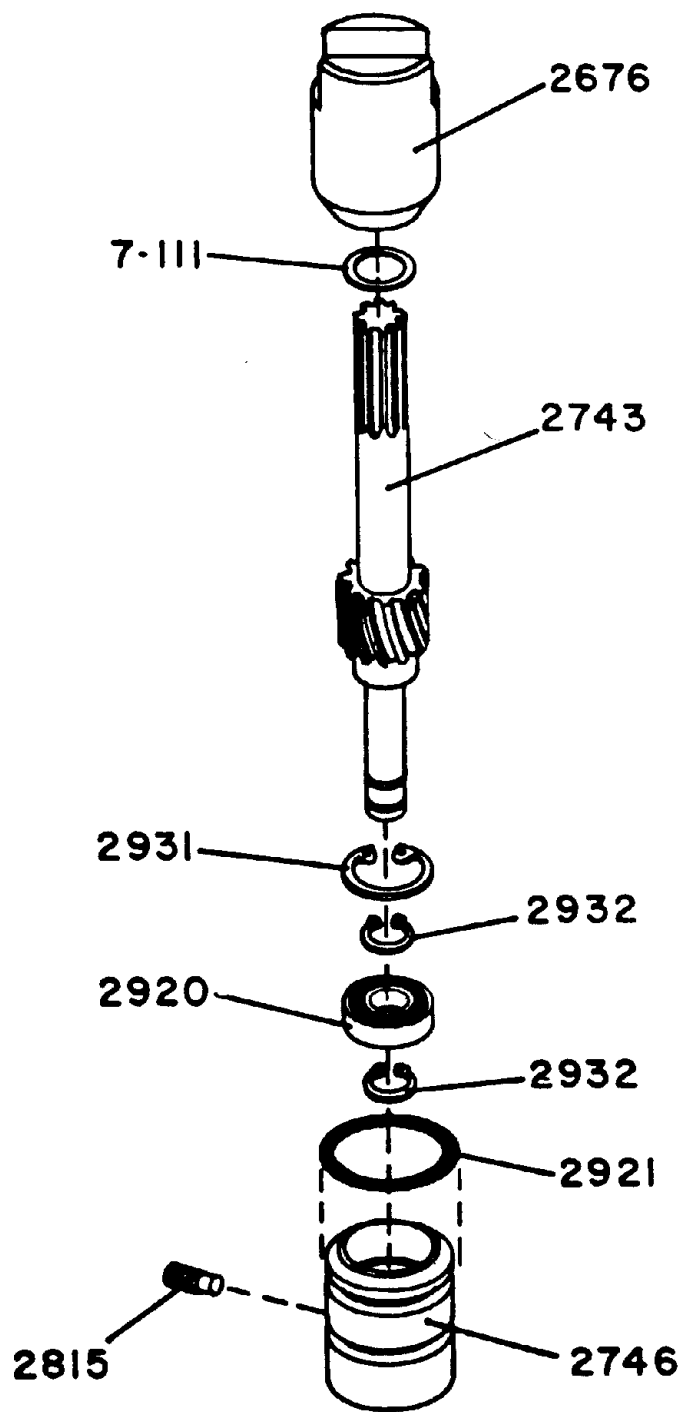

VERTICAL FRAMING ASSEMBLY

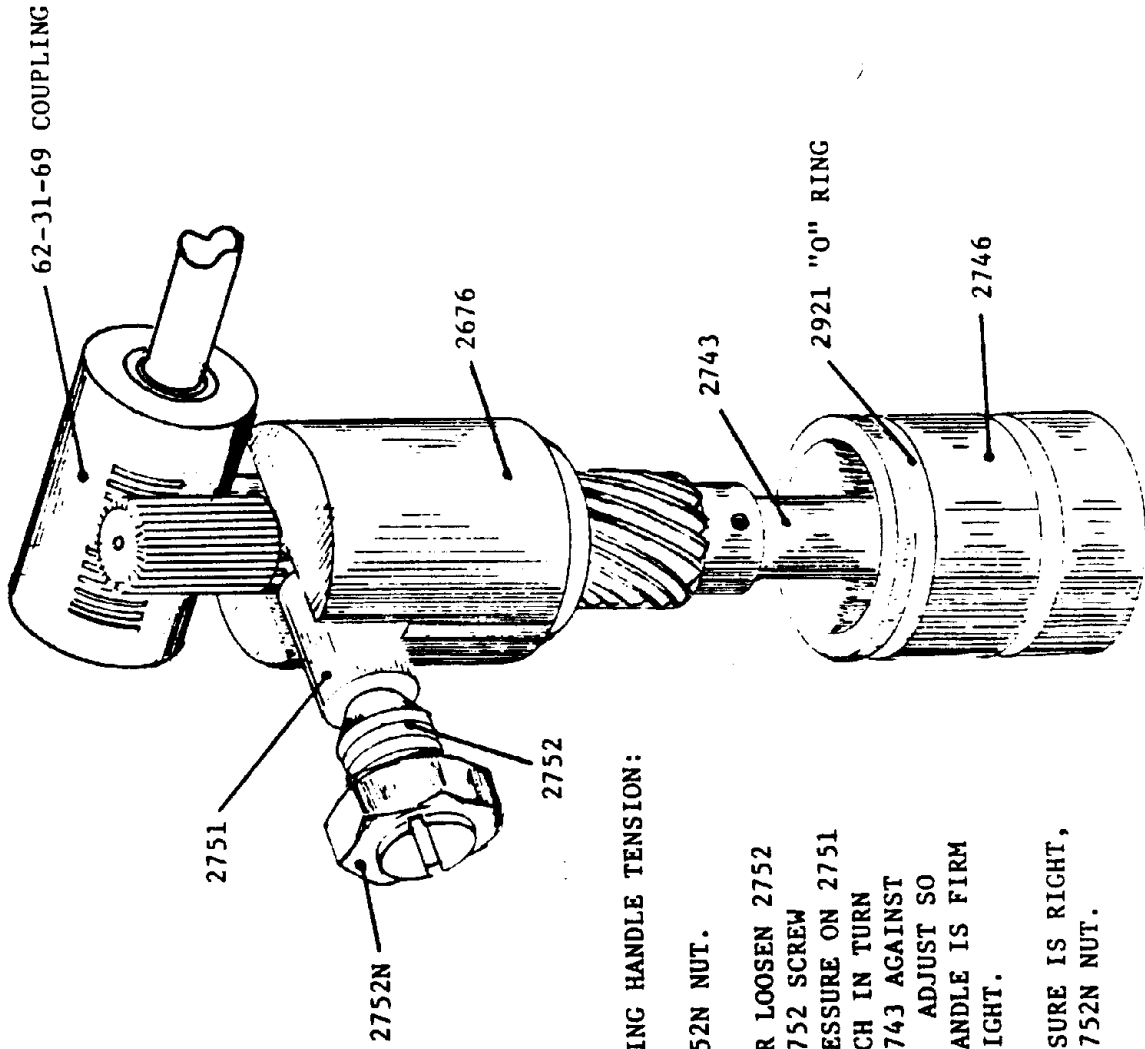

35

TO ADJUST FRAMING HANDLE TENSION:

- A LOOSEN 2752N NUT.
- B TIGHTEN OR LOOSEN 2752 SCREW. 2752 SCREW CAUSES PRESSURE ON 2751 PLUG, WHICH IN TURN PRESSES 2743 AGAINST COUPLING. ADJUST SO FRAMING HANDLE IS FIRM BUT NOT TIGHT.
- C WHEN PRESSURE IS RIGHT, TIGHTEN 2752N NUT.

VERTICAL FRAMING SHAFT & INTERMITTENT COUPLING

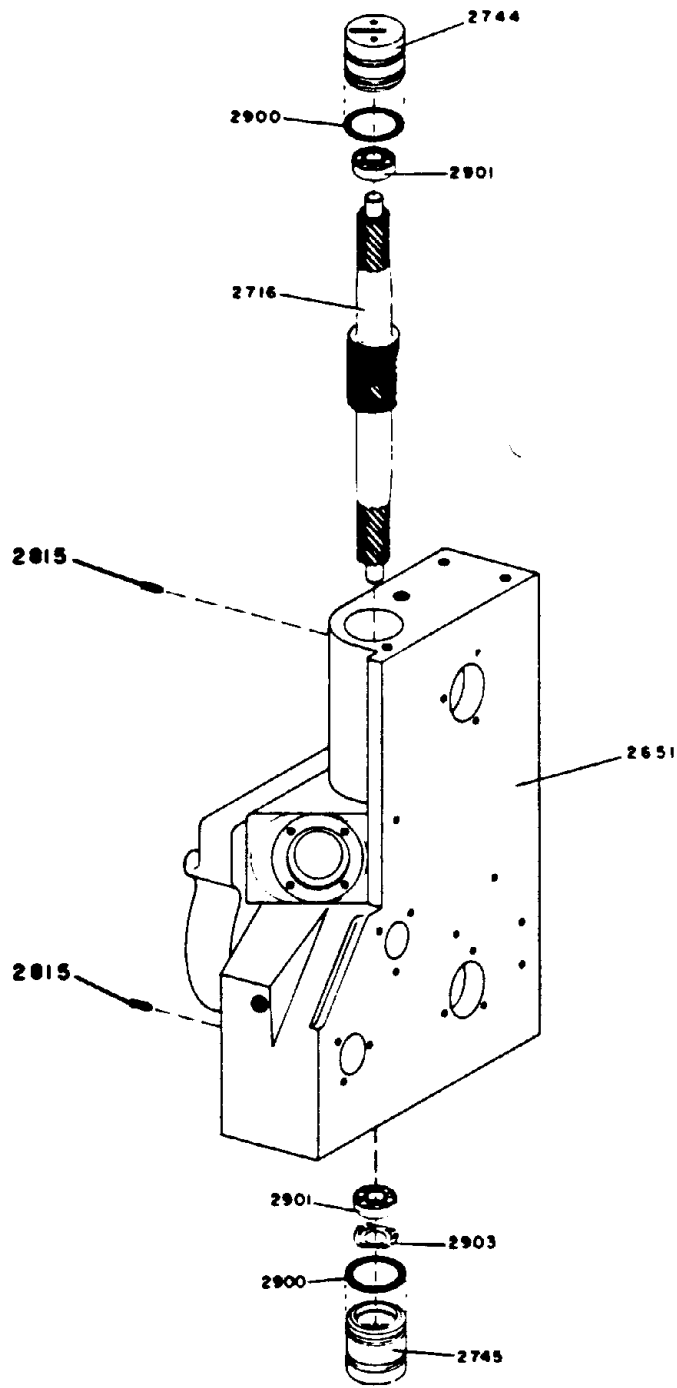

VERTICAL SHAFT ASSEMBLY

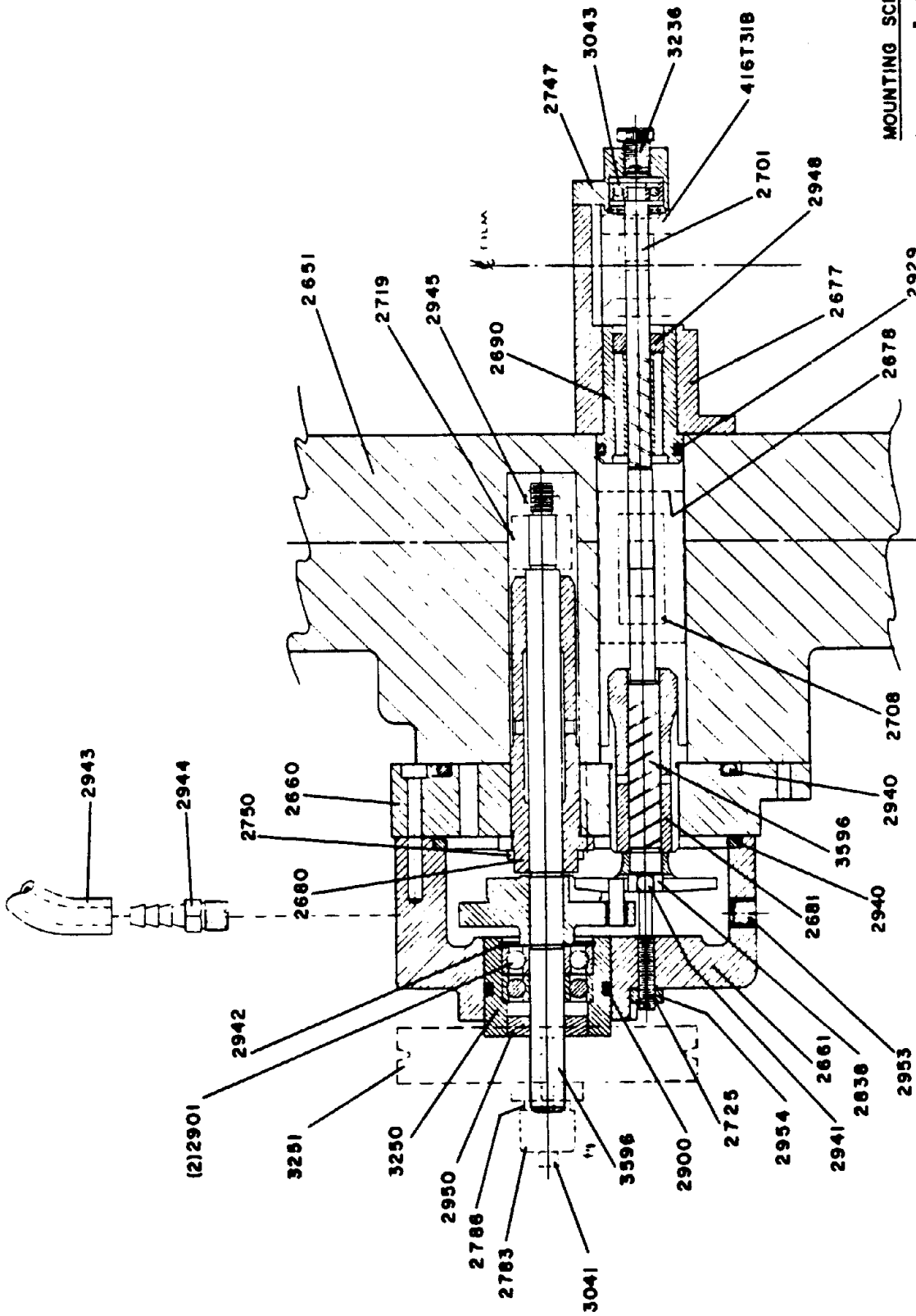

MOUNTING SCREWS NOT SHOWN

- (3) 1/4-20 X 1" - PARTS 2660 TO 2651
- (3) 10-32 X 1 1/4" - PARTS 2661 TO 2660
- (1) 10-32 X 1/2" - PARTS 2750 TO 2660

BALLANTYNE OF OMAHA, INC.

1712 JACKSON STREET

OMAHA, NEBRASKA

INTERMITTENT ASSEMBLY

SCALE 1:1	DRAWING NO. 2705
DATE 2/23/50	DESIGNED BY J.S. GIBSON REVISED 3/12/51

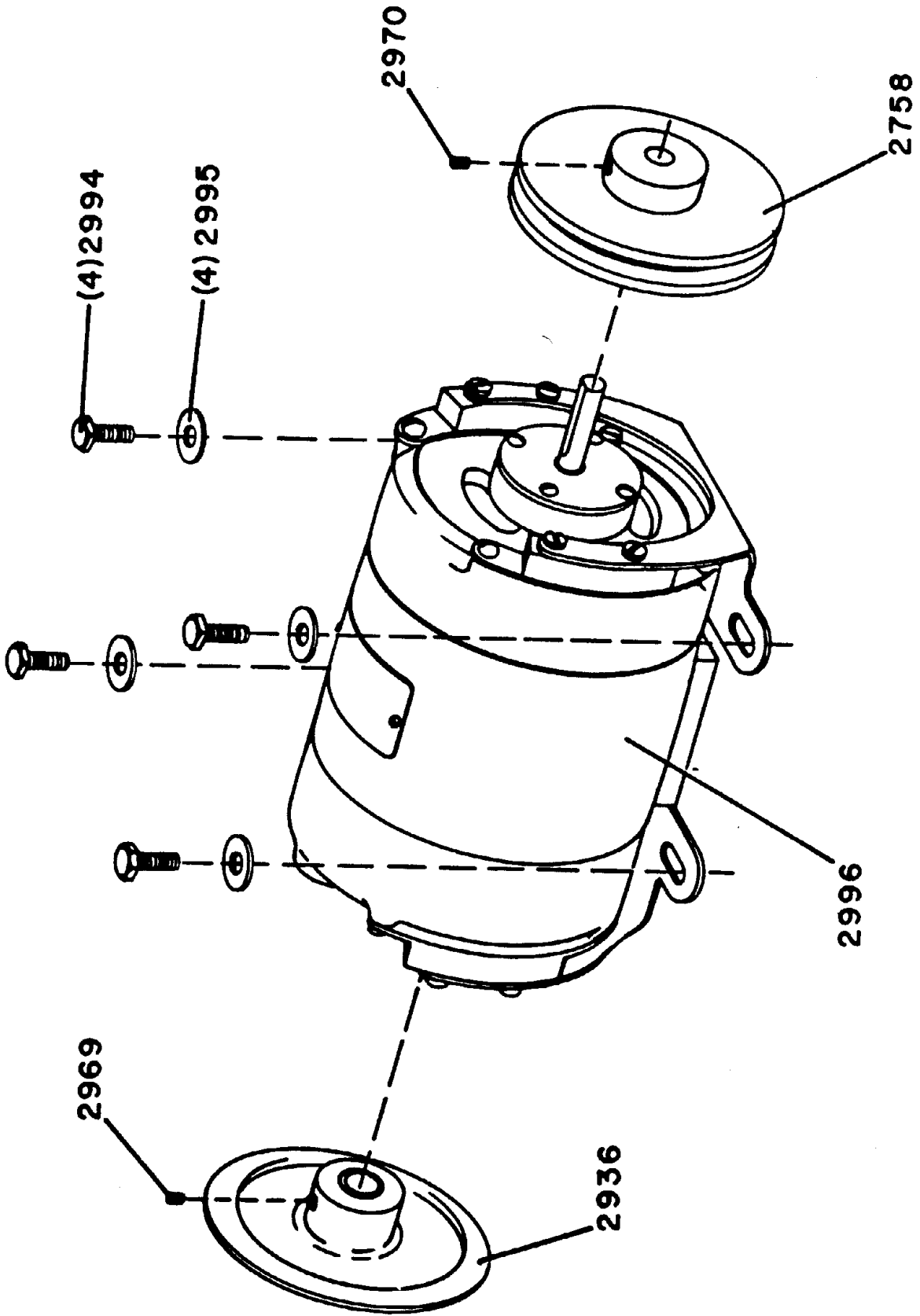

MOTOR ASSEMBLY

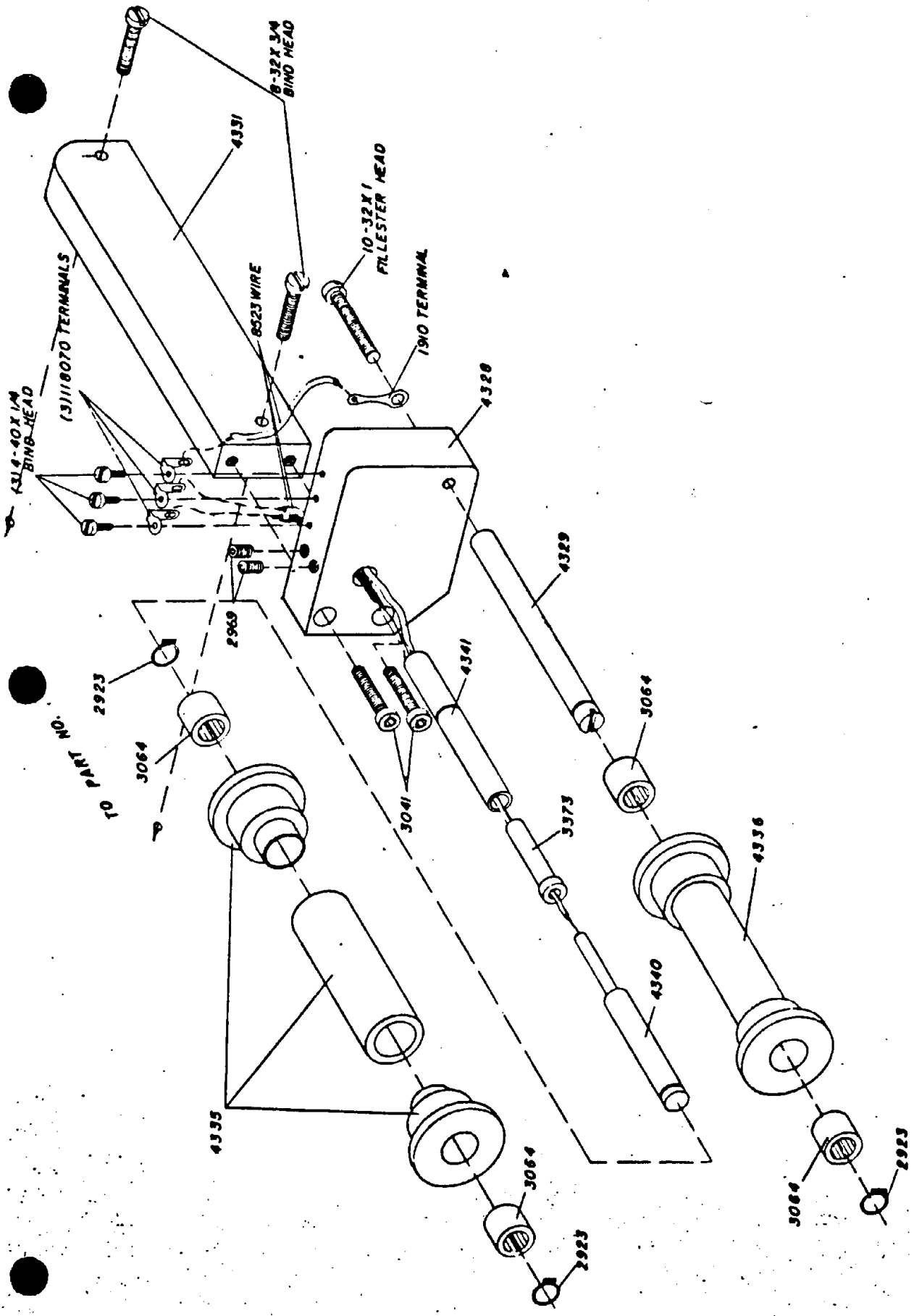

ASSEMBLY P8223

BALLANTYNE OF OMAHA, INC	
178 JACKSON ST	
PHONE NO 392-4444	
SCALE	DRAWING NO.
DATE 7 DEC 79	4342
REV	REV
	3064

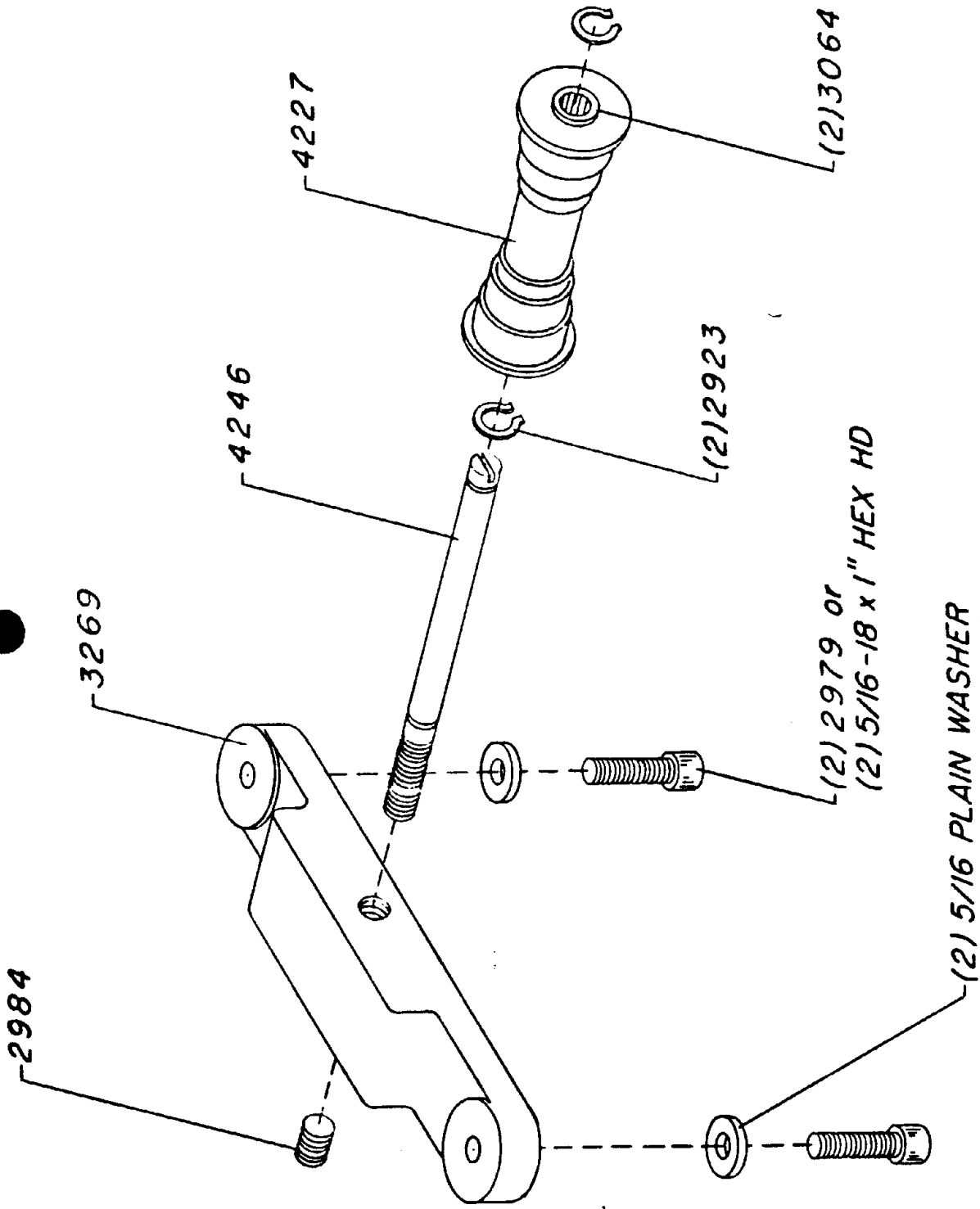

P8099
LOWER FILM GUIDE ASSEMBLY

HOLE NO. 24 ON
MODEL VII SOUNDHEAD

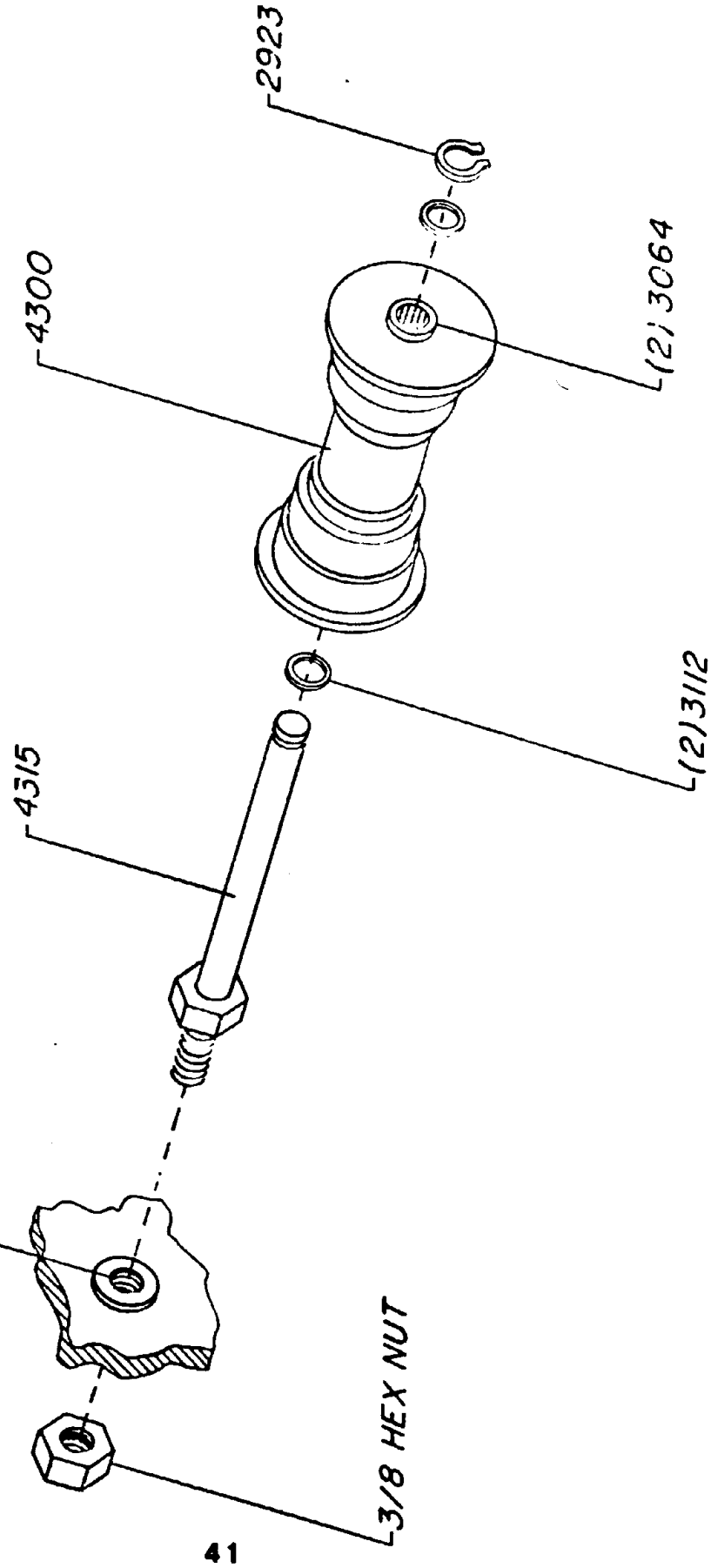

P8159
TAKE-UP GUIDE ROLLER
ASSEMBLY

h. 14 A

2919

CHANGE-OVER COIL

FRAMING LAMP

USED ONLY FOR TWO PROJECTORS

CLOSE

OPEN

120V

2 AMP

19-P-23

200 25W

60MFD 350V

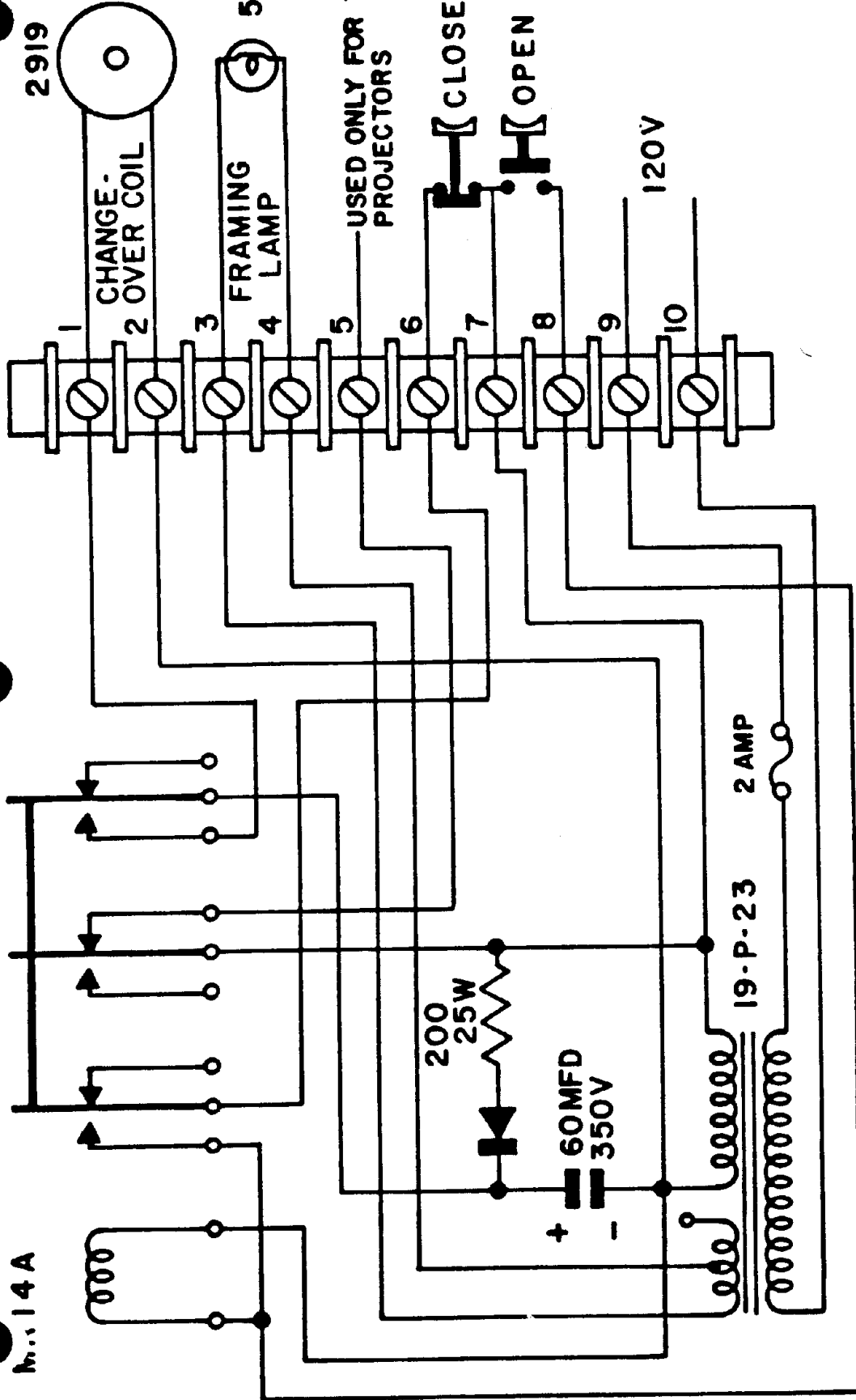

BALLANTYNE OF OMAHA, INC.

TELEPHONE 342-4444

1712 JACKSON STREET

OMAHA, NEBRASKA

3017A SINGLE CHANGE-OVER POWER SUPPLY

SCALE

DRAWING NO.

DATE 11/14/72

3302

DRAWN BY L.W.POLSLEY

REVISED

GENERAL ELECTRIC 1/8 HP
 SPLIT PHASE PROJECTOR
 DRIVE MOTORS

5KC29MG3706T 115V 50-60Hz
 CAPACITOR 98Mfd 165V

RELAY KLIXON 4CR-1-664

5KC29MG3747-T 230V 50-60Hz
 CAPACITOR 28Mfd 330V

RELAY KLIXON 4CP-1-627

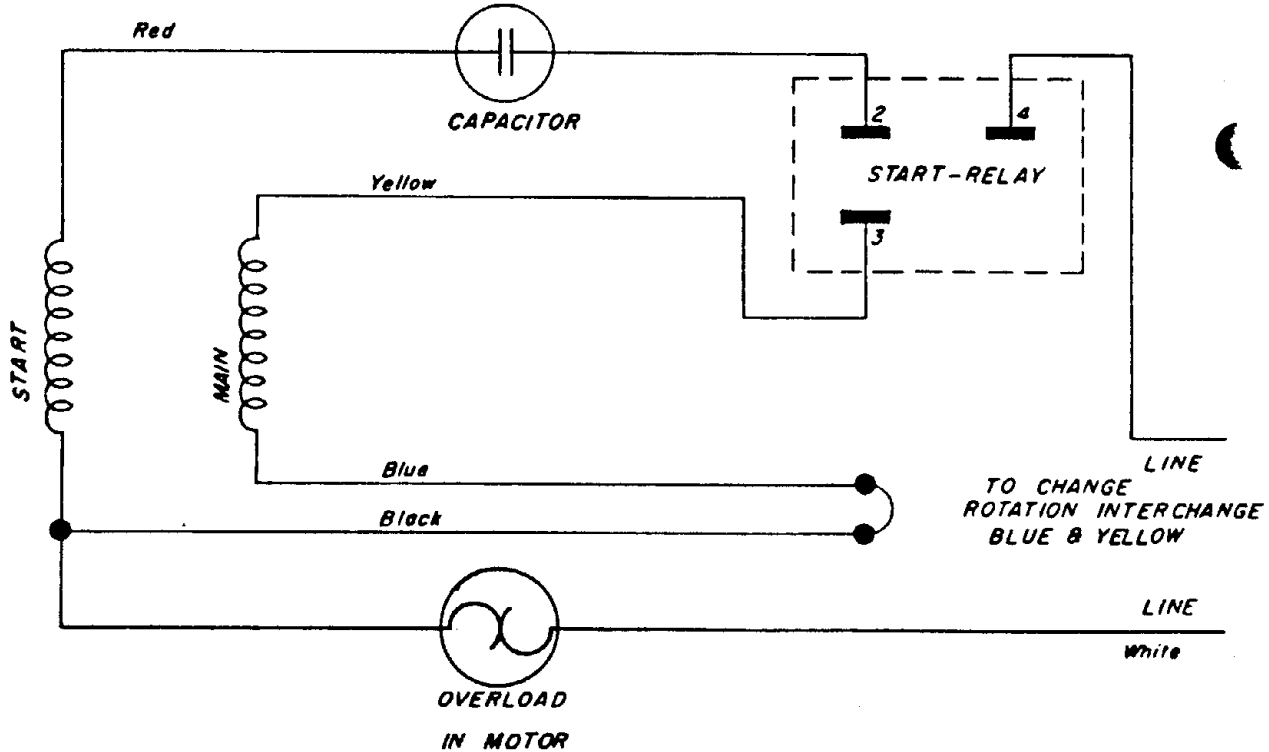

BALLANTYNE OF OMAHA, INC.

1712 JACKSON ST.

PHONE NO. 342-4444

G.E. 1/8 HP MOTOR WIRING DIA.

SCALE

DRAWING NO.

DRN. BY *W. H. P. 204*

DATE 2/8/80

4049

REV.

TO CHANGE COUPLING

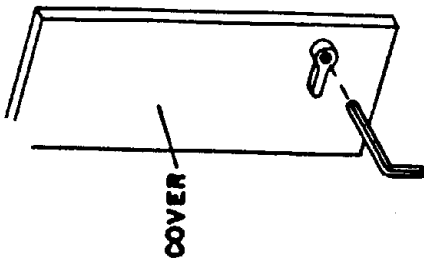

- ① DRAIN OIL
- ② REMOVE FRAMING HANDLE AND COVER
- ③ REPLACE FRAMING HANDLE
- ④ REMOVE FILM GATE

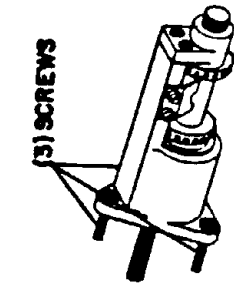

- ⑦ REMOVE THREE SCREWS & SHIELD AND WHILE MOVING FRAMING HANDLE, PULL SPROCKET ASSEMBLY TOWARD YOU.
- ⑧ COUPLING MAY COME OUT WITH SPROCKET ASSEMBLY. IF NOT, TURN FRAMING HANDLE SO COUPLING COMES FORWARD AND REMOVE WITH FINGERS.

- ⑤ LOOSEN SCREW 2780 AND REMOVE TRAP AND GATE SUPPORT. TRAP IS CENTERED ON DOWEL PINS AND REQUIRES REASONABLE PULL TO REMOVE.

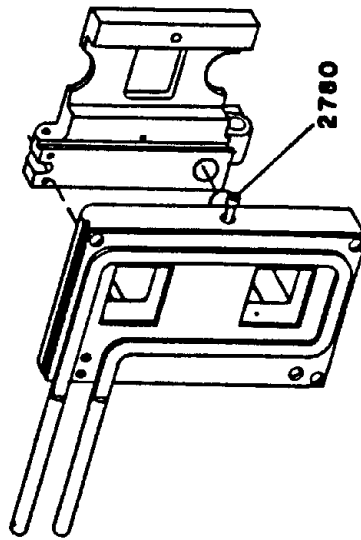

- ⑥ LOOSEN SCREW ⑥ ON REAR OF FRAME 1/4 TURN.

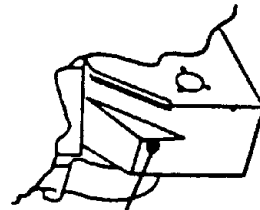

- ⑨ TAKE CAREFUL NOTICE OF THE END OF THE COUPLING AND PUT IT BACK ON THE SPROCKET SHAFT, EXACTLY AS IT CAME OFF. DO THIS SEVERAL TIMES TO GET THE "FEEL" OF THE FIT.
- ⑩ PUT THE COUPLING ON THE SPROCKET SHAFT AND PUSH BACK IN FRAME. ROTATE SPROCKET BACK AND FORTH TO ALIGN SPLEEN TO STAR SHAFT SPLEEN. IT WILL GO ON SHAFT WITH SAME "FEEL" AS ⑨ ABOVE. MAKE CERTAIN RACK TEETH FACE SHUTTER AND ARE VERTICAL.

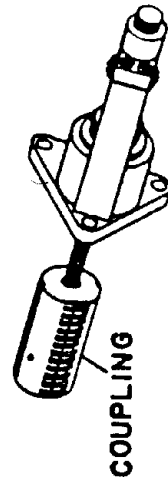

- ⑪ REPLACE ALL SCREWS AND REMOVED PARTS.
- ⑫ TIGHTEN SCREW ⑥ SO FRAMING HANDLE IS SNUG.

RE-TIME SHUTTER - SEE INSTRUCTION SHEET ON SHUTTER TIMING

TIMING SHUTTER

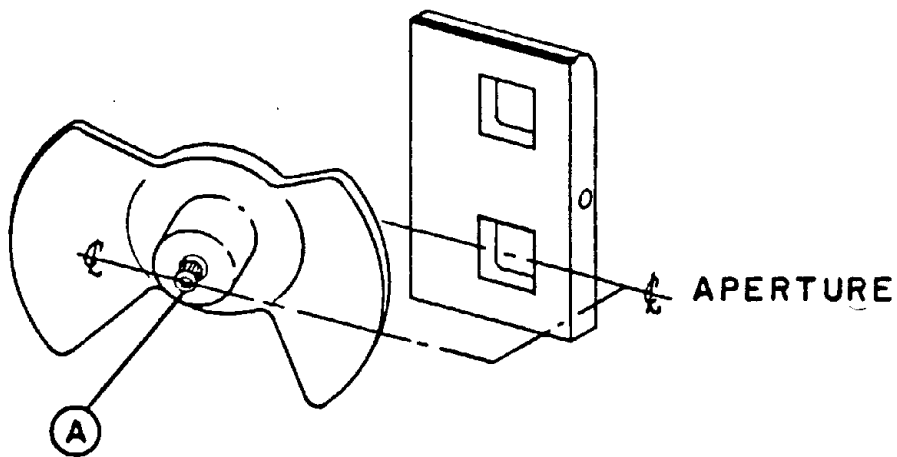

TURN PROJECTOR FORWARD BY MOTOR FLYWHEEL UNTIL SPROCKET TOOTH #3 IS AT INDICATOR. LOOSEN SCREW (A) AND TURN SHUTTER SO ϕ OF BLADE IS ON ϕ OF APERTURE OPENING.

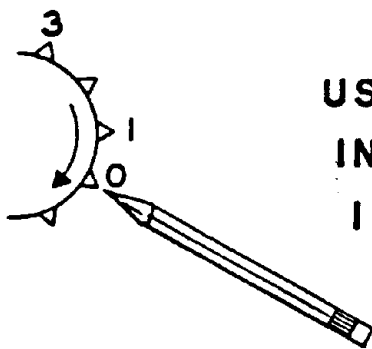

USE A POINTED OBJECT TO INDICATE POSITION OF INTERMITTENT TOOTH WHEN IN STOPPED POSITION.

ELECTRO SOUND

4 TRACK MAGNETIC PICKUP

ASSEMBLY NO. 0210101-01

HEAD ONLY NO. 3710201-01

SERIAL NOS. 160 & 161

CANNON - FEMALE SOCKET DA-15S

ELECTRO NO. 629-00-23-15

CANNON - MALE PLUG DA-15P

ELECTRO NO. 639-00-23-15

CANNON - CAP DA-19678-1

ELECTRO NO. 599-000-8-01

FEMALE SOCKET CONNECTION

DA-15S - TO MAG. CLUSTER

PINS 1 & 9 CHANNEL - 3 - ORANGE - BLK.

PINS 3 & 11 CHANNEL - 4 - YELLOW - BLK.

PINS 5 & 13 CHANNEL - 2 - RED - BLK.

PINS 7 & 15 CHANNEL - 1 - BROWN - BLK.

PIN 8 CORE GROUNDS WHITE - BLK TR.

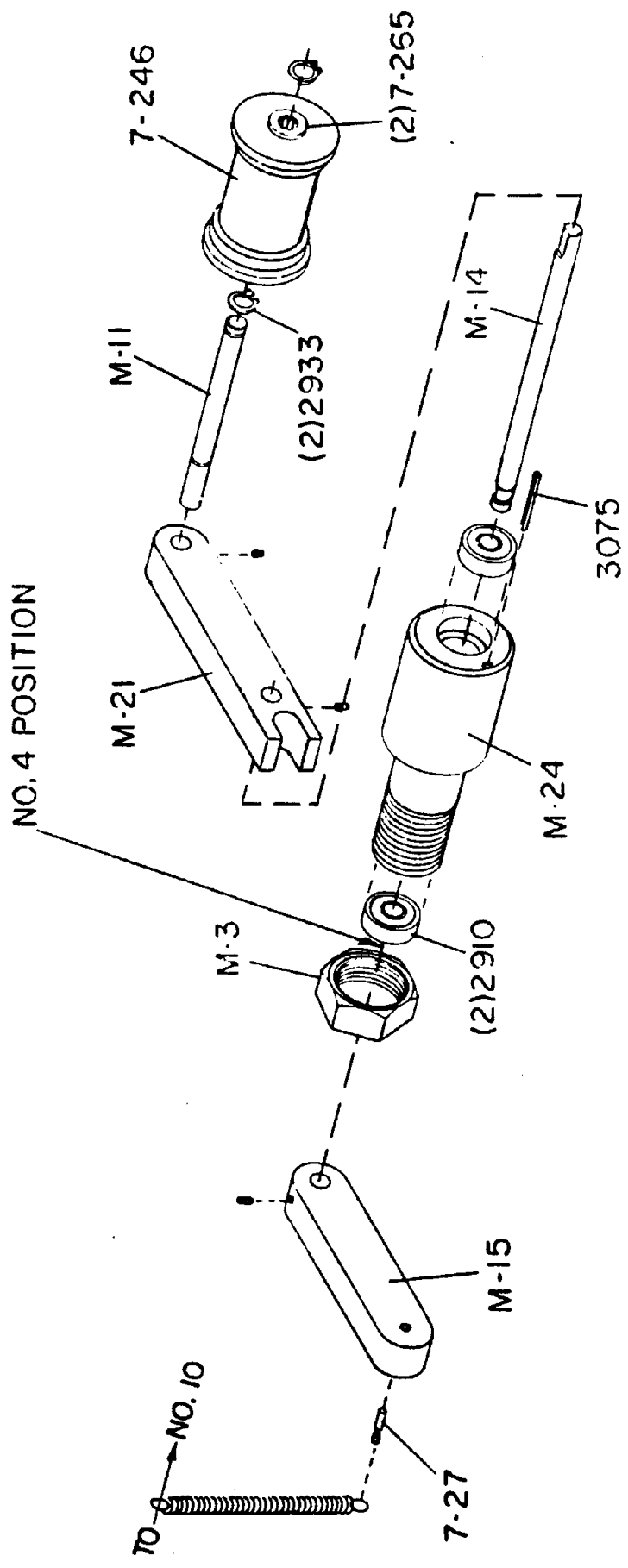

P8119

PENTHOUSE CLUSTER TENSION ADJUSTMENT

POSITION NO. 4 - 70MM PENTHOUSE

P8119

<u>PART NO.</u>	<u>DESCRIPTION</u>	<u>AMOUNT USED</u>
2910	Bearing	2
2933	"C" Ring	2
2969	10/32 X 1/4 S.S.	3
3075	Pin	1
3868	Spring	1
4230	Bushing	1
4232	Shaft	1
4247	Guide Roller	1
4249	Pad Roller Shaft	1
M-3	Nut For 4230 Bushing	1
M-15	Support Arm	1
M-21	Guide Roller Support Arm	1
7-27	Spring Pin	1
7-67	Washer	4
7-265	Needle Bearing	2

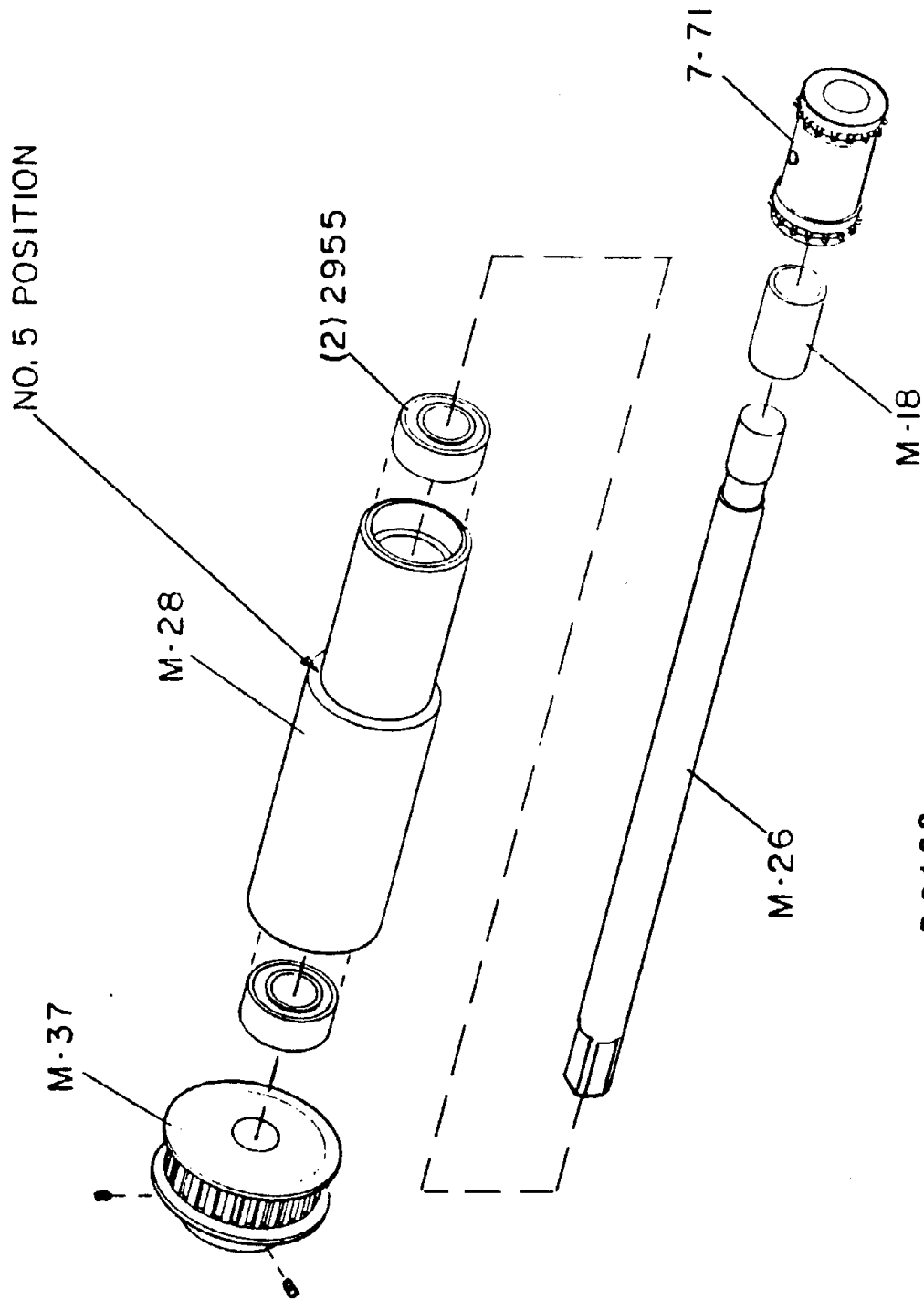

P 8120

PENTHOUSE SPROCKET AND DRIVE ASSEMBLY

NO 3735

POSITION NO. 5 - 70MM PENTHOUSE
P8120

<u>PART NO.</u>	<u>DESCRIPTION</u>	<u>AMOUNT USED</u>
2955	Bearing	2
3052	1/4-20 X 3/8 S.S.	1
4422	Sprocket "620C50B"	1
M-26	Sprocket Shaft	
M-27	Part of P8176	
M-37	Gilmer Pulley	
7-73	"C" Ring	1
7-111	Fibre Spacer Washer	As Needed

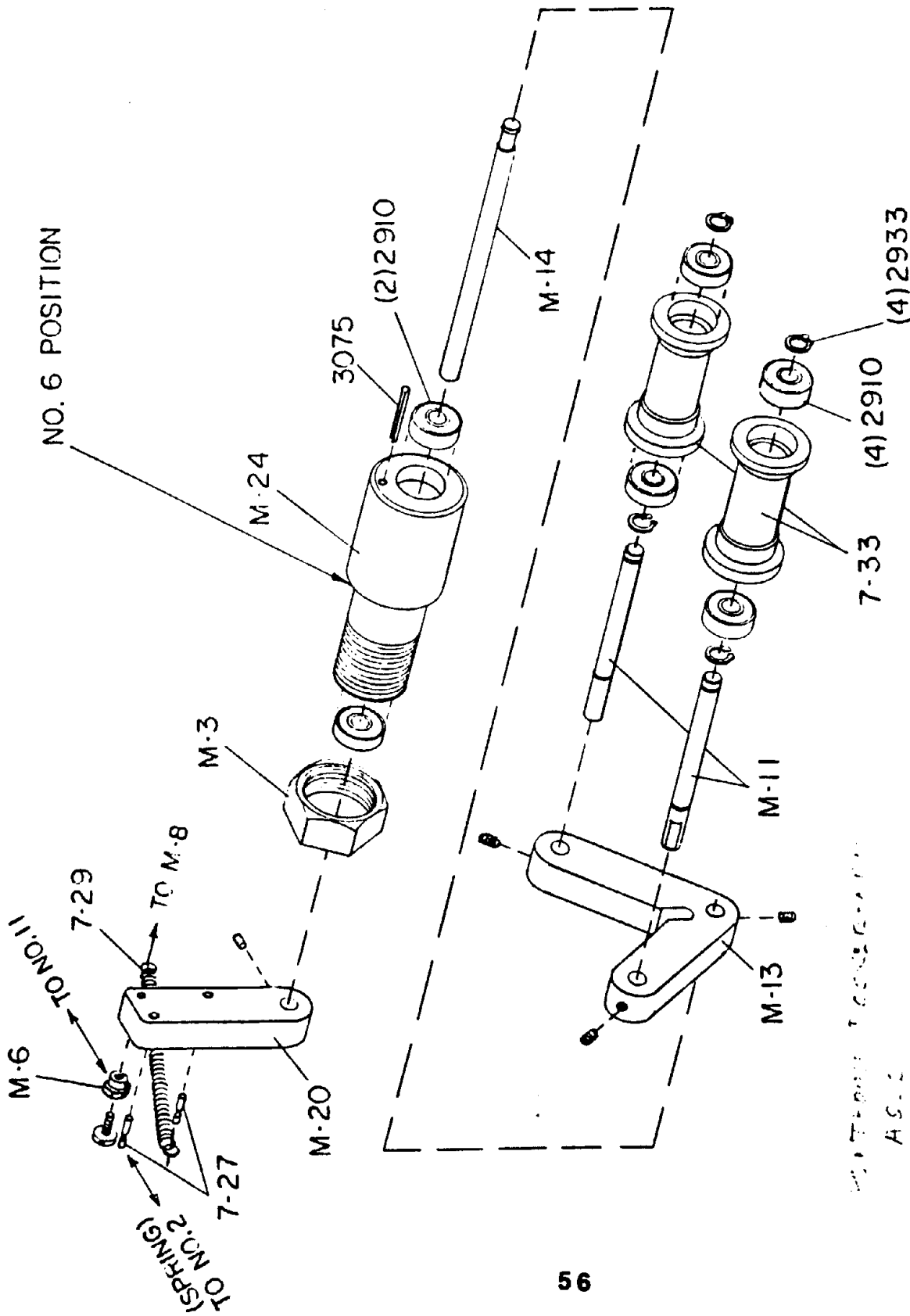

W. T. ...
A.S. 2

PENTHOUSE ROCKER-ARM ASSEMBLY

P 8121

POSITION NO. 6 - 70MM PENTHOUSE

P8121

<u>PART NO.</u>	<u>DESCRIPTION</u>	<u>AMOUNT USED</u>
2910	Bearing	6
2933	"C" Ring	4
2969	Set Screw	3
3075	Stop Pin (Also in P8119)	1
4226	Film Guide Roller	2
4230	Bushing (Also in P8119)	1
4231	Guide Roller Shaft	2
4232	Pivot Shaft (Also in P8119)	1
M-3	Bushing Nut (Also in P8119)	1
M-6	Nut	1
M-13	"V" Support Bracket	1
M-20	Support Bracket	1
7-27	Spring Pin	2
7-67	Fibre Washer	2
	6/32 X 3/8 Bind Head	1

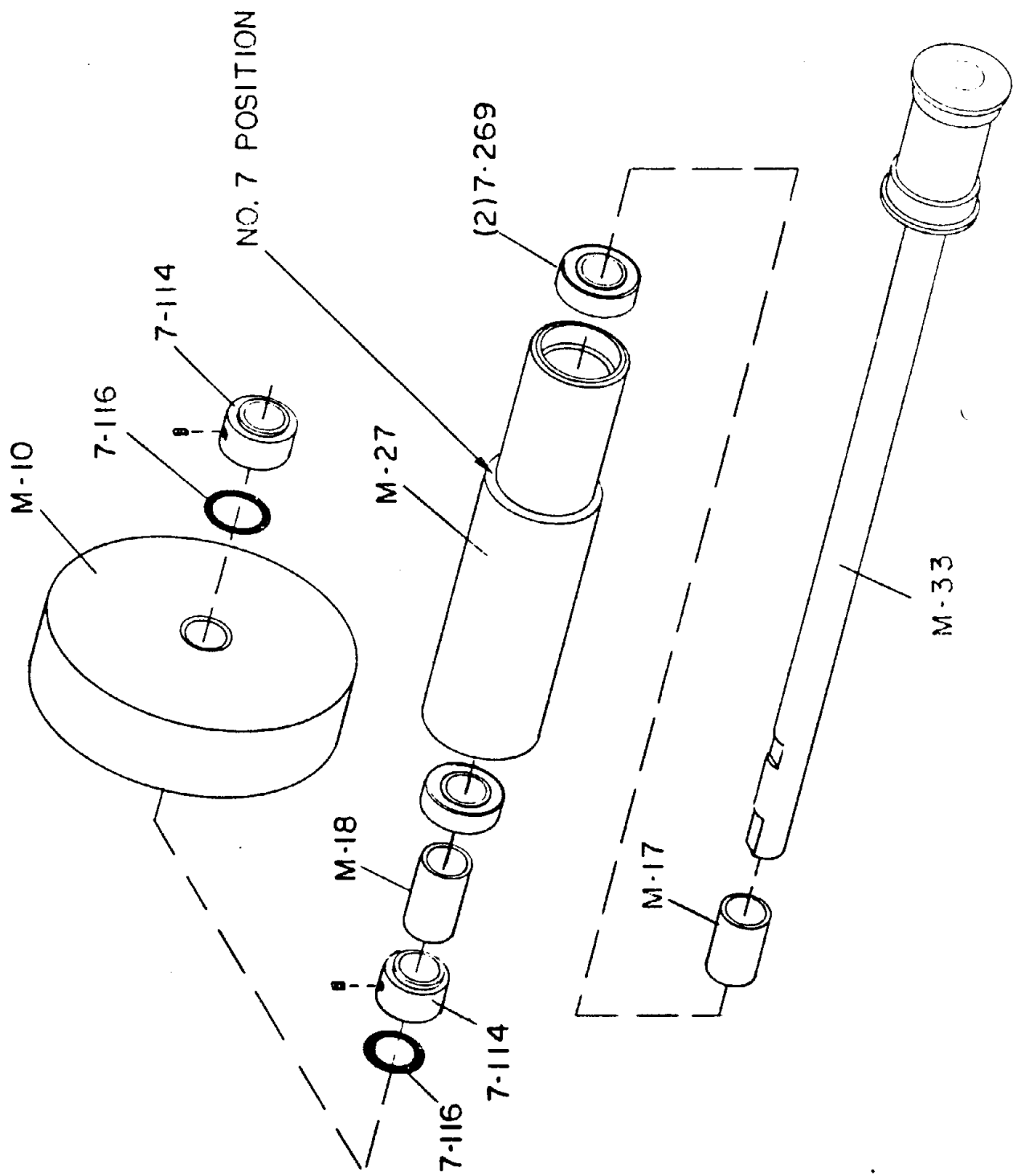

POSITION NO. 7 - 70MM PENTHOUSE
P8122

<u>PART NO.</u>	<u>DESCRIPTION</u>	<u>AMOUNT USED</u>
2969	10/32 X 1/4 Socket Set Screw	2
4224	Guide Roller Shaft & Stabilizer	1
M-10	Flywheel	1
M-18	Spacer	1
M-27	Part of P8176	1
7-114	Collar	2
7-116	Washer	2
7-269	Bearing	2

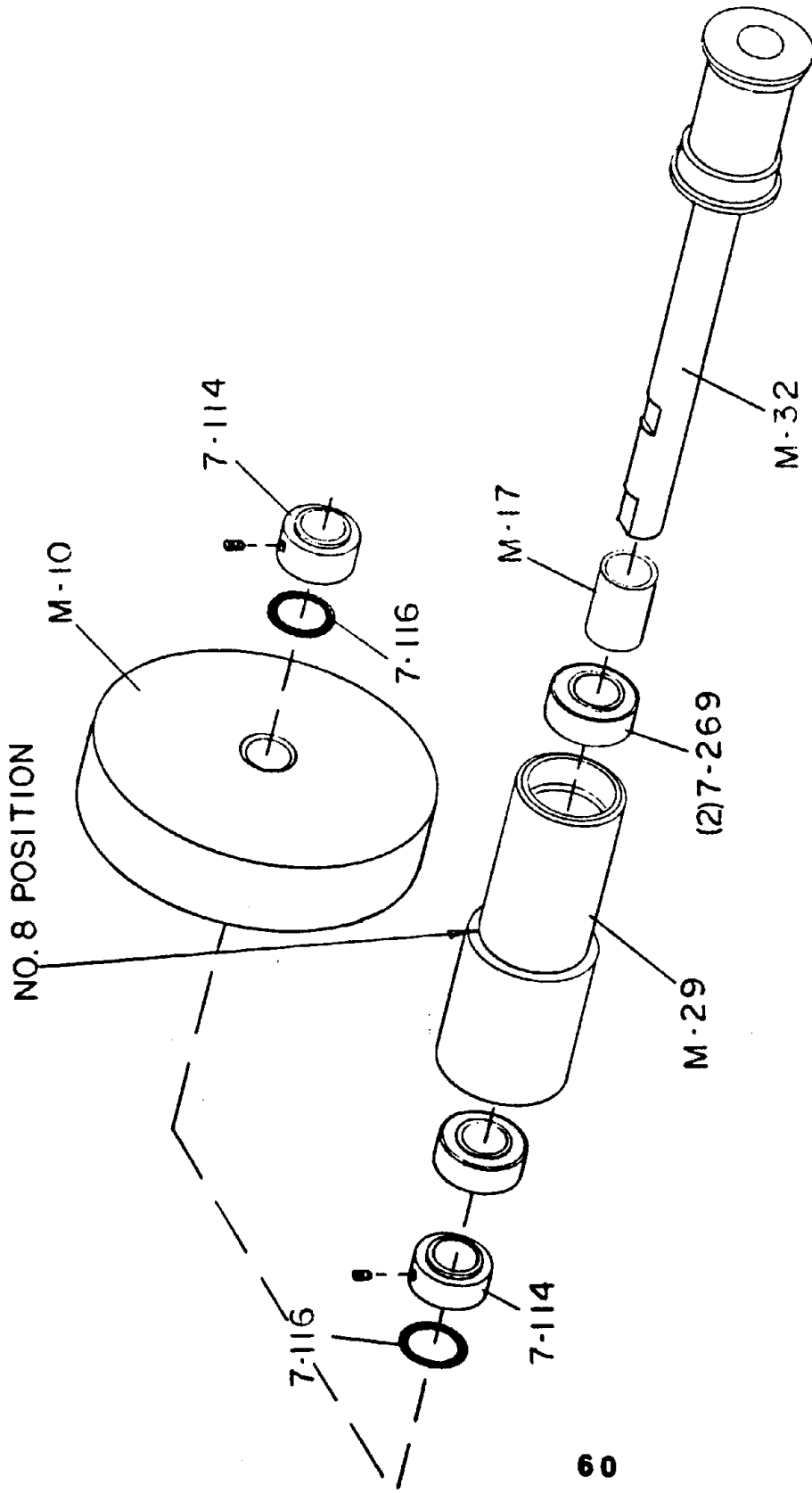

PENTHOUSE STABILIZER ASSEMBLY NO. 2

P 8123

POSITION NO. 8 - 70MM PENTHOUSE

P8123

<u>PART NO.</u>	<u>DESCRIPTION</u>	<u>AMOUNT USED</u>
2969	10/32 X 1/4 Socket Set	2
4223	Stabilizer & Shaft	1
M-10	Flywheel	1
M-29		1
7-114	Collar	2
7-116	Washer	2
7-269	Bearing	2

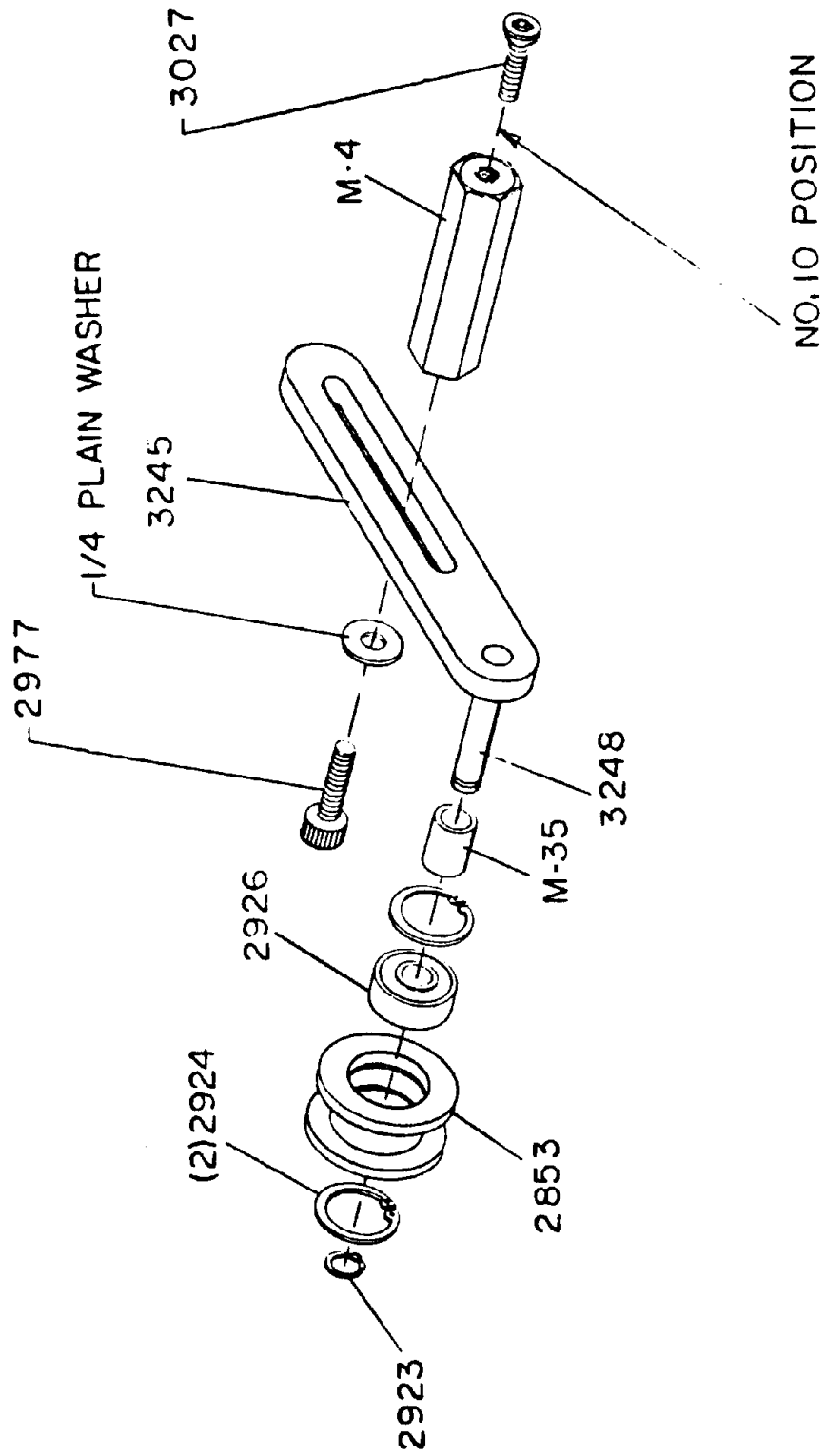

PENTHOUSE BELT IDLER ASSEMBLY

P 8124

BELT TIGHTENER ASSEMBLY FOR PENTHOUSE

P8124

<u>PART NO.</u>	<u>DESCRIPTION</u>	<u>AMOUNT USED</u>
2853	Sheave Idler Pulley	1
2923	Snap Ring	1
2924	Snap Ring	2
2926	Bearing	1
2977	1/4-20 X 1 Socket Head Cap Screw	1
3027	1/2-20 X 3/4 Socket Head Cap Screw Flat Head	1
3245-48	Idler Arm & Shaft	1
M-4	3/4 Idler Spacer	1
M-35	Spacer	1
	1/4 Flat Washer	1

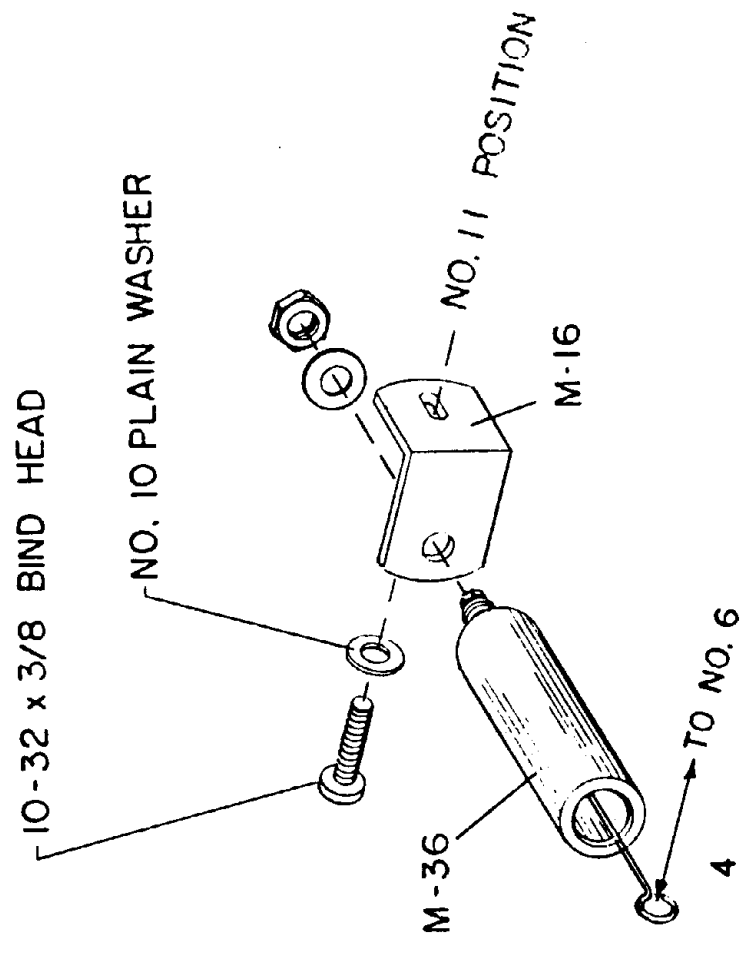

PENTHOUSE AIR DASHPOT

P 8125

POSITION NO. 11 - 70MM PENTHOUSE

P8125

<u>PART NO.</u>	<u>DESCRIPTION</u>	<u>AMOUNT USED</u>
M-16	Air Pot Mounting Bracket	1
M-36	Nut	1
	10/32 X 3/8 Bind Head	1
	#10 Flat Washer	1

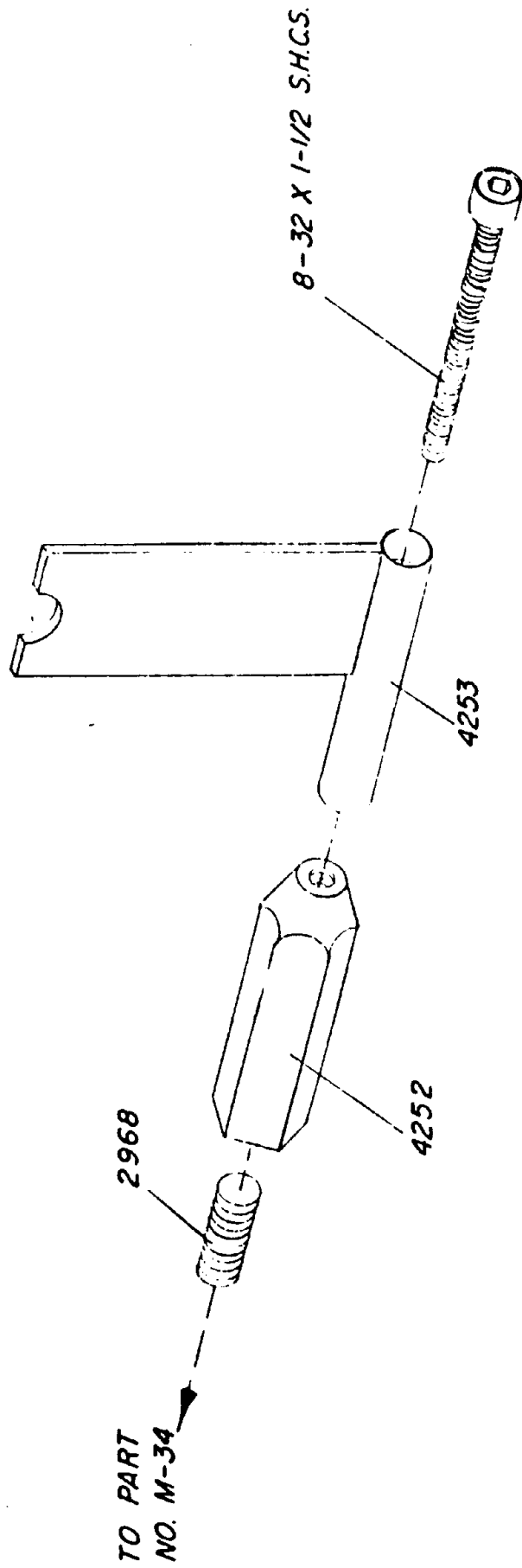

POSITION NO. 12 - 70MM PENTHOUSE
P8126

2968	1/4-20 X 1/2 Socket Set Screw	1
	8/32 X 1-1/2 Socket Cap	1
4252	Stripper Support	1
4253	Stripper	1

1/4-20 x 5/8 HEX HD.

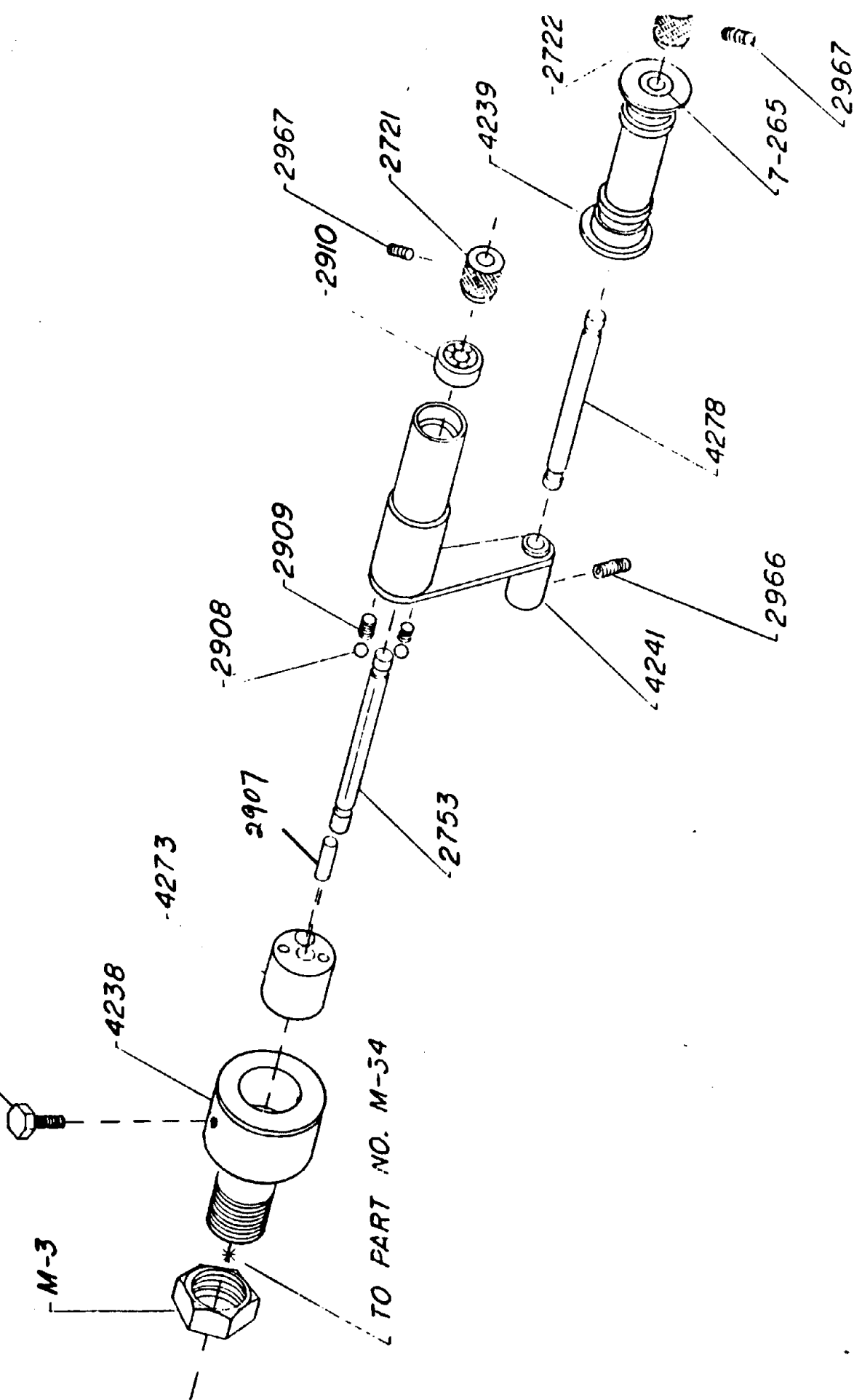

TO PART NO. M-34

POSITION NO. 1 - 70MM PENTHOUSE

P8160

<u>PART NO.</u>	<u>DESCRIPTION</u>	<u>AMOUNT USED</u>
2722	Knurled Collar	1
2753	Detent Shaft	1
2907	Dowel Pin	1
2908	Steel Ball	2
2909	Spring For Steel Ball	2
2910	Bearing	1
2965	10/32 X 1/4 S.S.	1
2966	10/32 X 1/8 S.S.	1
2967	8/32 X 1/8 S.S.	2
4238	Bushing	1
4239	Pad Roller	1
4241	Support Arm	1
4273	Detent Block	1
4278	Pad Roller Shaft	1
M-3	Nut	1
7-21	Knurled Collar	1
7-265	Bearing	2
	10/32 X 1/2 Hex HD Bolt	1

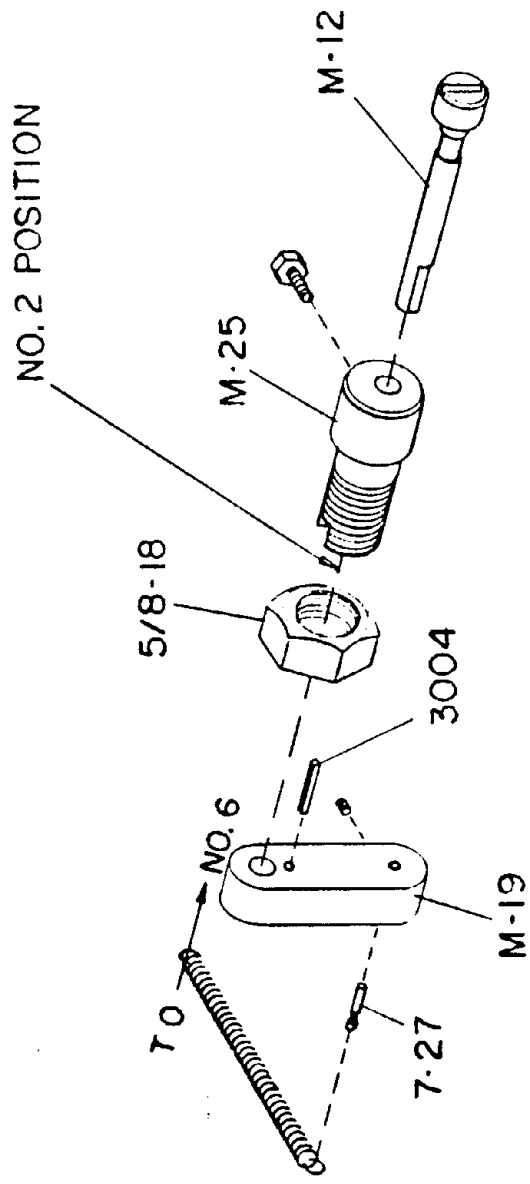

PENTHOUSE ROCKER ARM ADJUSTMENT ASSEMBLY

P 8161

POSITION NO. 2 - 70MM PENTHOUSE

P8161

<u>PART NO.</u>	<u>DESCRIPTION</u>	<u>AMOUNT USED</u>
2969	10/32 X 1/4 Socket Set	1
2970	1/4-20 X 1/4 Socket Set	1
3004	3/32 X 9/16 Roll Pin	1
3868	Spring	1
4258	Bushing	1
5/8-18	Hex Nut Stock With #4258	1
M-8S	Spring Stock With M-8	1
M-12R	Shaft	1
M-19	Support Block	1
7-27	Pin	1

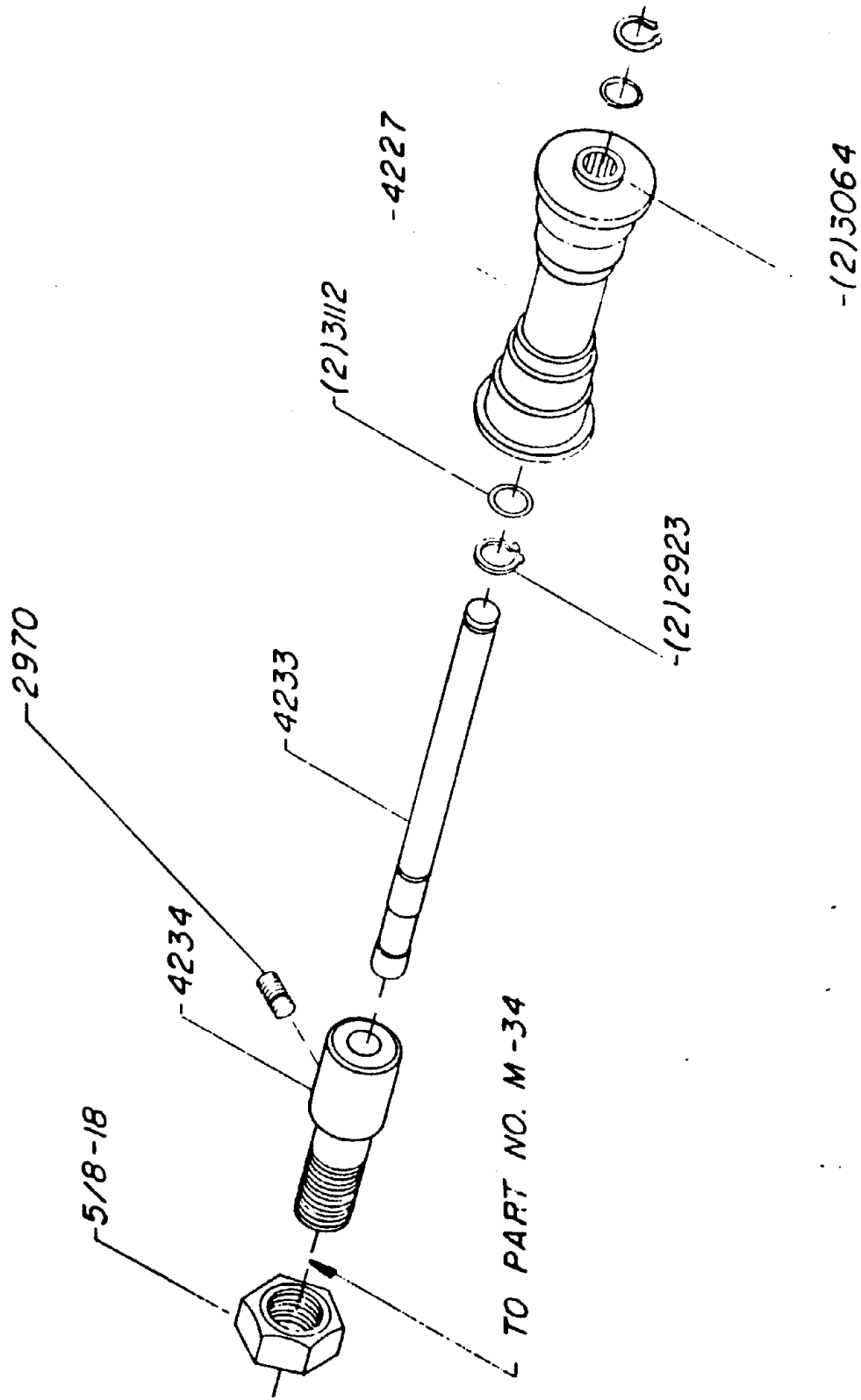

POSITION NO. 3 - 70MM PENTHOUSE
P8162

<u>PART NO.</u>	<u>DESCRIPTION</u>	<u>AMOUNT USED</u>
2923	"C" Ring	2
2970	1/4-20 X 1/4 Socket Set Screw	1
3112	1/32 Fibre Washer	2
3064	Needle Bearing	2
4227	Guide Roller	1
4233	Guide Roller Shaft	1
4234	Bushing	1
	5/8-18 Hex Nut Stock With 4258	1

TO
PART
M-30
OR
M-31

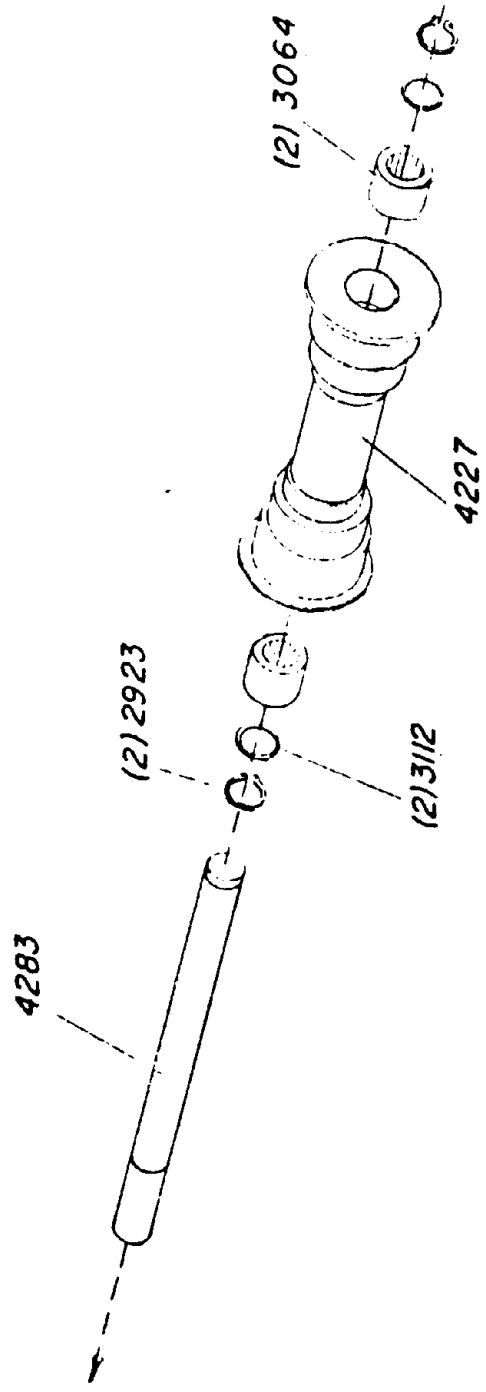

ASSEMBLY P8175

TOP PLATE FILM ROLLER 35/70

P8175

<u>PART NO.</u>	<u>DESCRIPTION</u>	<u>AMOUNT USED</u>
2923	"C" Ring	2
3064	Needle Bearing	2
3112	1/32 Fibre Washer	2
4227	Guide Roller	1
4283	Guide Roller Shaft	1

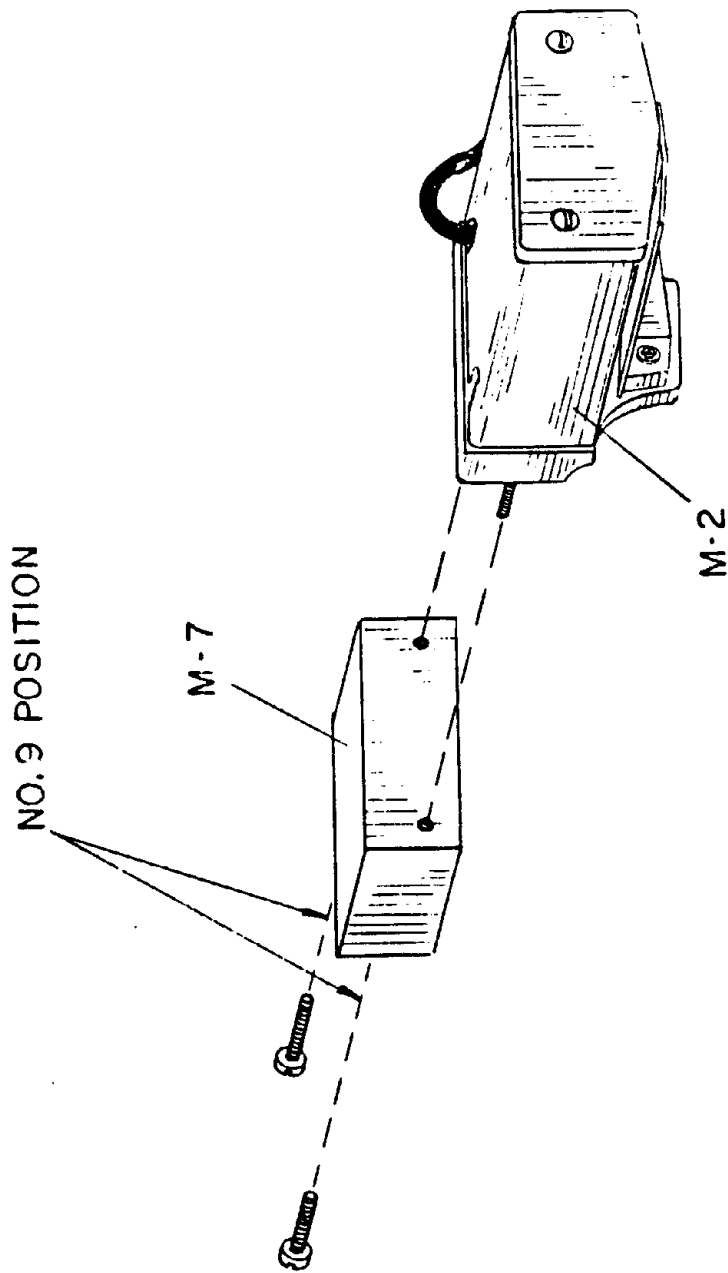

PENTHOUSE MAGNETIC CLUSTER

P 8225

POSITION NO. 9 - 70MM PENTHOUSE
P8225

<u>PART NO.</u>	<u>DESCRIPTION</u>	<u>AMOUNT USED</u>
2974	8/32 X 5/8 Socket Cap	2
2975	10/32 X 1 Socket Cap	2
4229	Magnetic Cluster Mounting Block	1
4276	70MM Magnetic Cluster	1

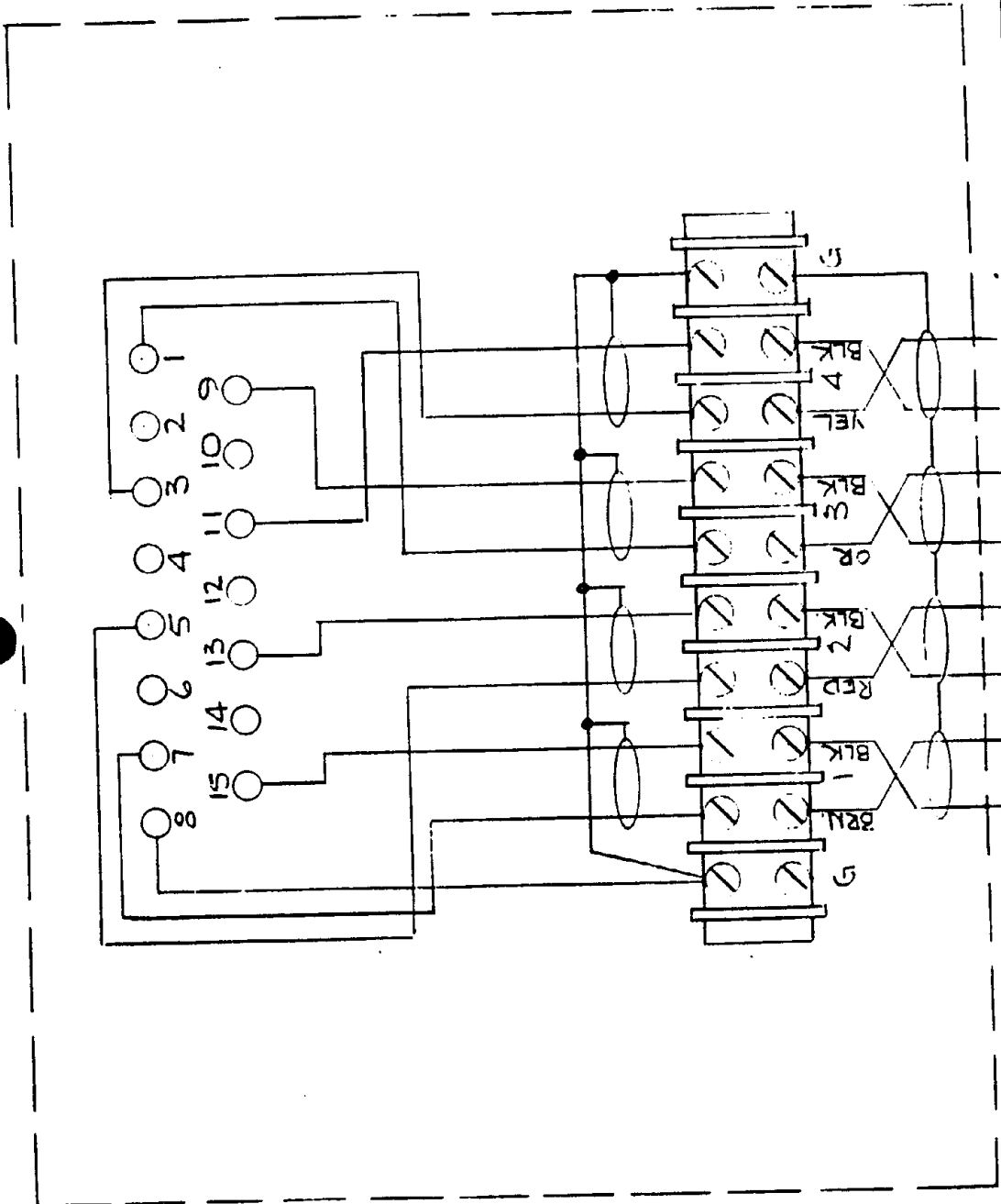

BALLANTYNE OF OMAHA, INC.

TELEPHONE 342-4444

OMAHA, NEBRASKA

1712 JACKSON STREET

(MAGNETIC)

SCALE	DRAWING NO.	DRAWN BY
DATE 3/10/76	3613	REVIS

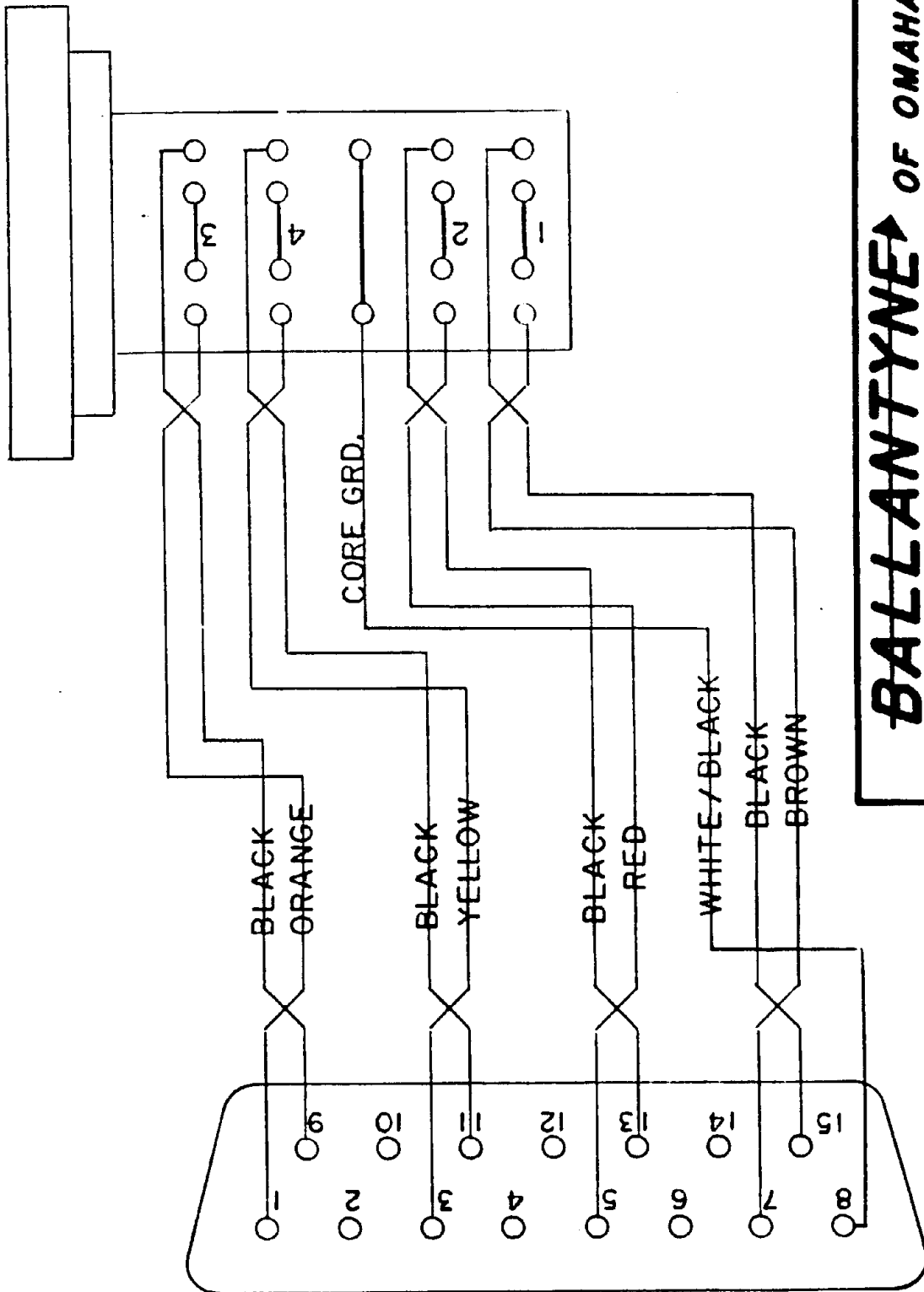

BALLANTYNE OF OMAHA, INC.

TELEPHONE 342-4444

1712 JACKSON STREET

OMAHA, NEBRASKA

HOOK-UP ELECTRO-SOUND MAGNETIC CLUSTER

SCALE

DRAWING NO.

DRAWN BY

DATE 6/4/75

3561

REVISED

35 CONVERSION FOR USE W/35 SPYDER			
PARTS NEEDED	P8242	DESCRIPTION	USAGE
2833R		PRESSURE PAD	1

AS OF - 4/28/82-#0053

MASTER BILL-OF-MATERIAL REPORT

PAGE

22-60220 P8242 35MM PRESSURE PAD

 PIN # T DESCRIPTION

4

21-35002	P	*N227E*NUT (SPECIAL) CAP	#	2	EA
21-51001	P	*S1279E*SCREW	#	2	EA
21-58002	P	*S1280E*SPRING	#	2	EA
21-70005	P	*W-278-E*WASHER	#	2	EA
21-98056	P	*2833R*ONE-PIECE GATE PAD (FLAT)	#	1	EA
22-20672	M	4460 PRESSURE PAD PLATE	#	1	EA
90-60000	L	LABOR		8	MIN
95-60000	V	OVERHEAD		8	MIN

TOTAL COST 8.0

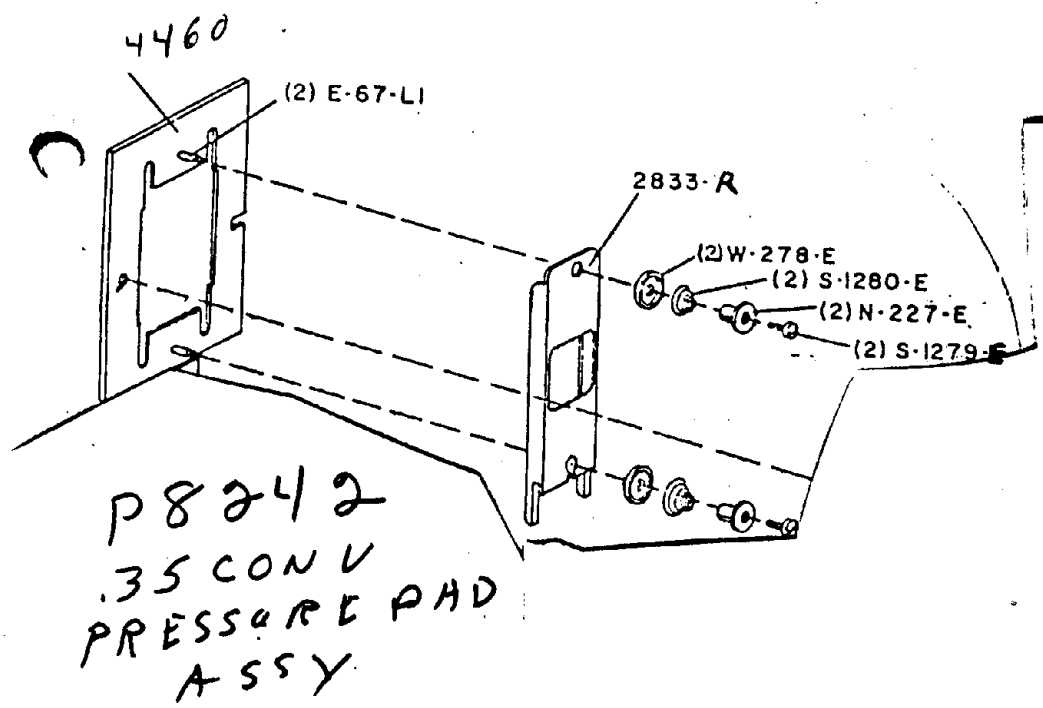

22-60219 P8241 35MM SPYDER SHOE ASSEMBLY (CONVERS)

PIN # T DESCRIPTION

QTY UNIT

PIN #	T	DESCRIPTION	QTY	UNIT
21-37034	P	4484 DOWEL PIN 1/8 X 1"	1	EA
21-51008	P	*S1511E*STUD SCREW	4	EA
21-58034	P	4298 SPRING	1	EA
21-58035	P	4299 SPRING	1	EA
22-20518	M	4262 TENSION SHOE ARM	1	EA
22-20526	M	4270 SPYDER SPRING RETAINER	1	EA
22-20529	M	4275 SPYDER FLOATING STUD	1	EA
22-20670	M	4458 35MM TENSION SHOE	2	EA
22-40542	M	4459 35MM SPYDER	1	EA
22-40555	M	4269 SPYDER SPRING CAP	1	EA
41-51170	P	*2967*8 - 32 X 1/8 CUP PT. SOCKET SET SC	1	EA
41-51206	P	*2971*10 - 32 X 3/8 BUTTON HEAD SOCKET S	1	EA
41-51250	P	*3088*10-32 X 1/4 BRASS CUP POINT SET SC	1	EA
90-60000	L	LABOR	12	MIN
95-60000	V	OVERHEAD	12	MIN
			TOTAL COST	12.0

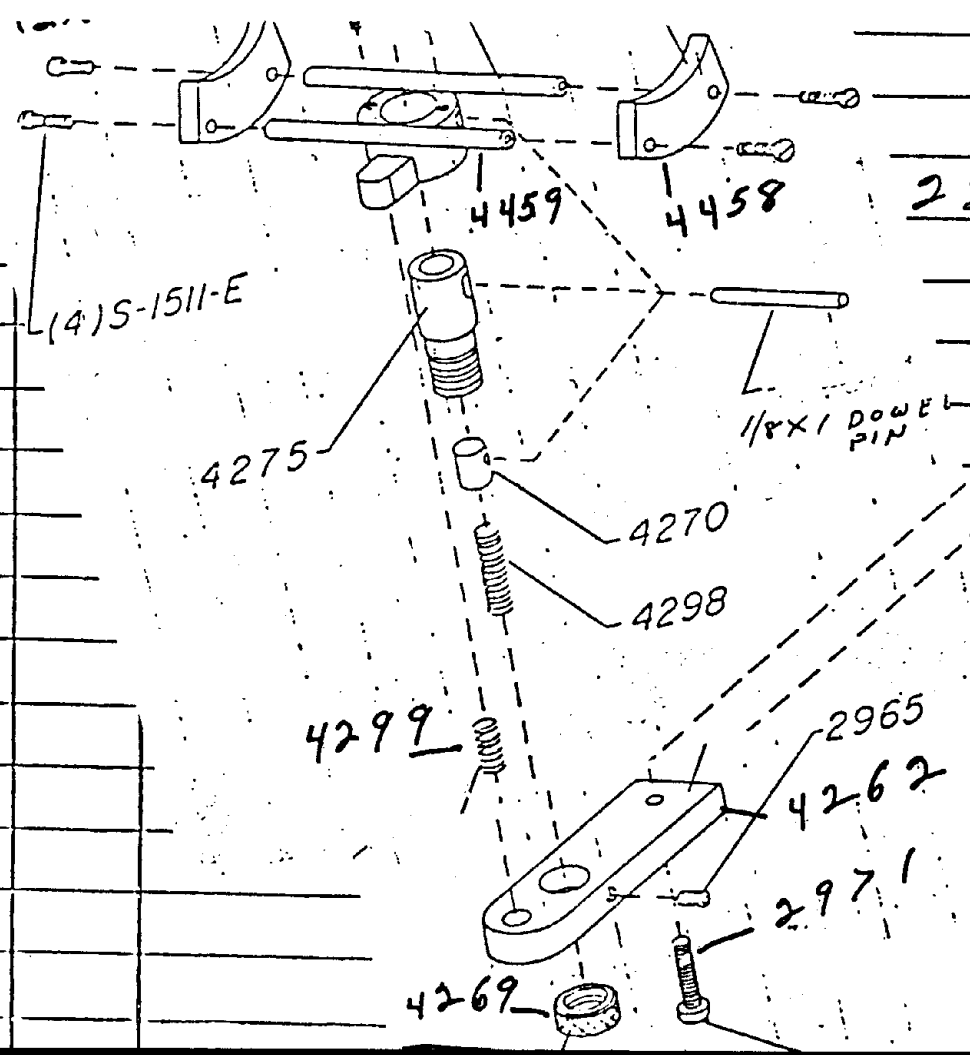

P8241
22-60219

22-60345 P8281 SPYDER SHOE ARM MOUNT

PIN # T DESCRIPTION

QTY UNIT

21-04003	P	*2910/7-23*BEARING	#	1	EA
21-37003	P	*2907*IDLER DETENT DWEL PIN 3/16"X7/8"	#	1	EA
21-98292	P	4273 DETENT	#	1	EA
22-00008	M	*7-21* KNUKLED COLLAR	#	1	EA
22-20125	M	2753 PAD ROLLER ARM SHAFT	#	1	EA
22-20482	M	4207 TENSION SHOE DETENT	#	1	EA
22-40427	M	4268 DETENT KNOB	#	1	EA
31-04001	P	*F-15/2908*BEARING	#	2	EA
31-58001	P	*F-14/2909*SPRING	#	2	EA
41-51170	P	*2967*8 - 32 X 1/8 CLP PT. SOCKET SET SC		2	EA
41-51178	P	*2969*10-32 X 1/4 CUP PT. SOCKET SET SCR		1	EA
90-60000	L	LABOR		15	MIN
95-60000	V	OVERHEAD		15	MIN

TOTAL COST 15.0

7011 12/14/81 5140

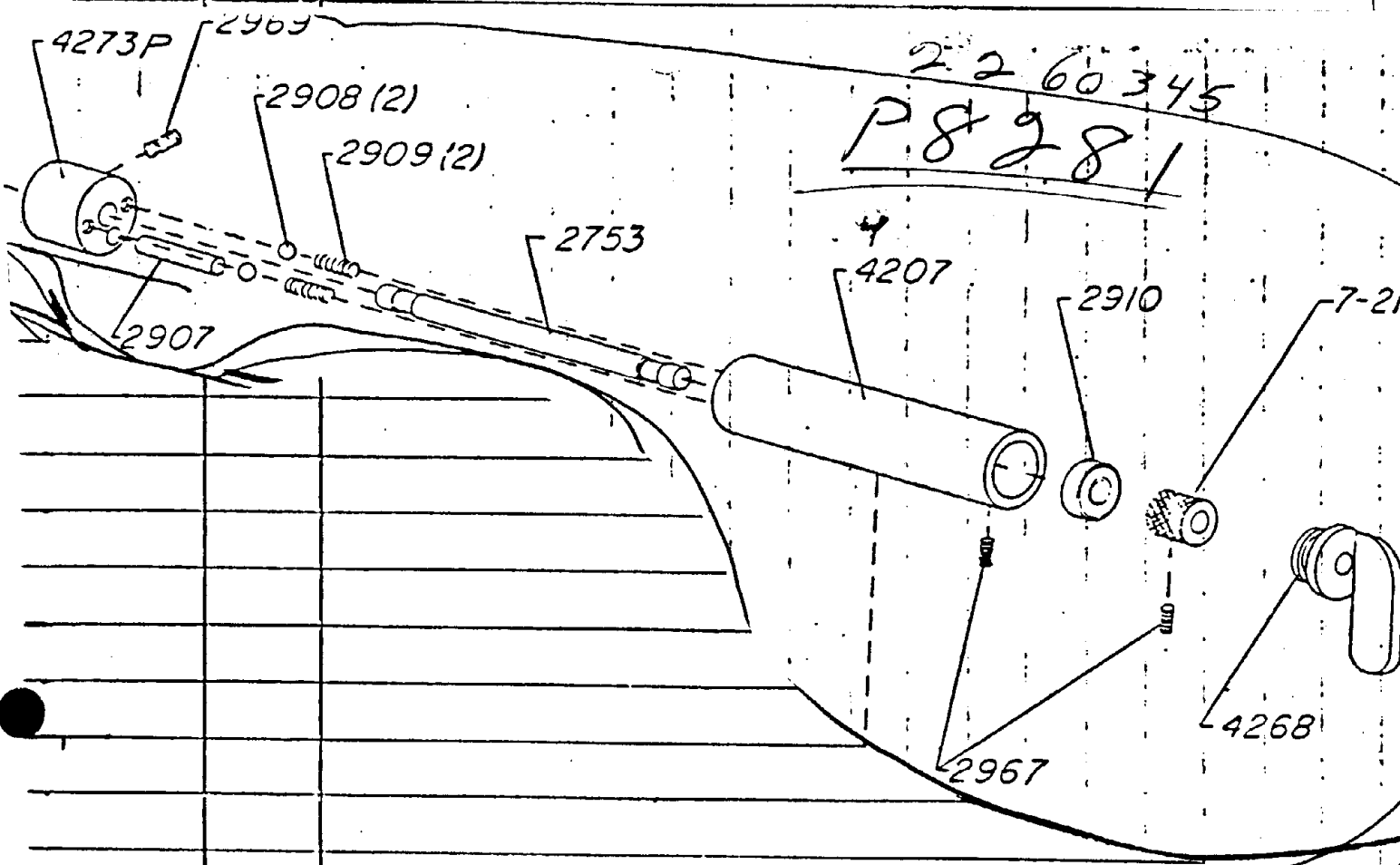

35 CONV. FILM RATE SUPPOR

AS OF - 8/28/82-#0054

MASTER BILL-OF-MATERIAL REPORT

PAGE 4

22-60264 29-88-4A 35 CONVERSION FIELD GATE SUPPOR

PIN #	T	DESCRIPTION	QTY	UNIT
21-37004	P	*2927*ROLL PIN (SPRING PIN 1/8" X 1/2")	1	EA
21-51003	P	*3047*NYLON SET SCREW	2	EA
21-51006	P	*2837-R2*CAPTIVE SCREW	1	EA
22-20673	M	4353 FILM TRAP COVER (35/70)	1	EA
22-20674	M	3090 FILM TRAP SET SCREW	2	EA
90-60000	L	LABCR	10	MIN
95-60000	V	OVERHEAD	10	MIN
TOTAL COST			10.0	

		CONV.	1
--	--	-------	---

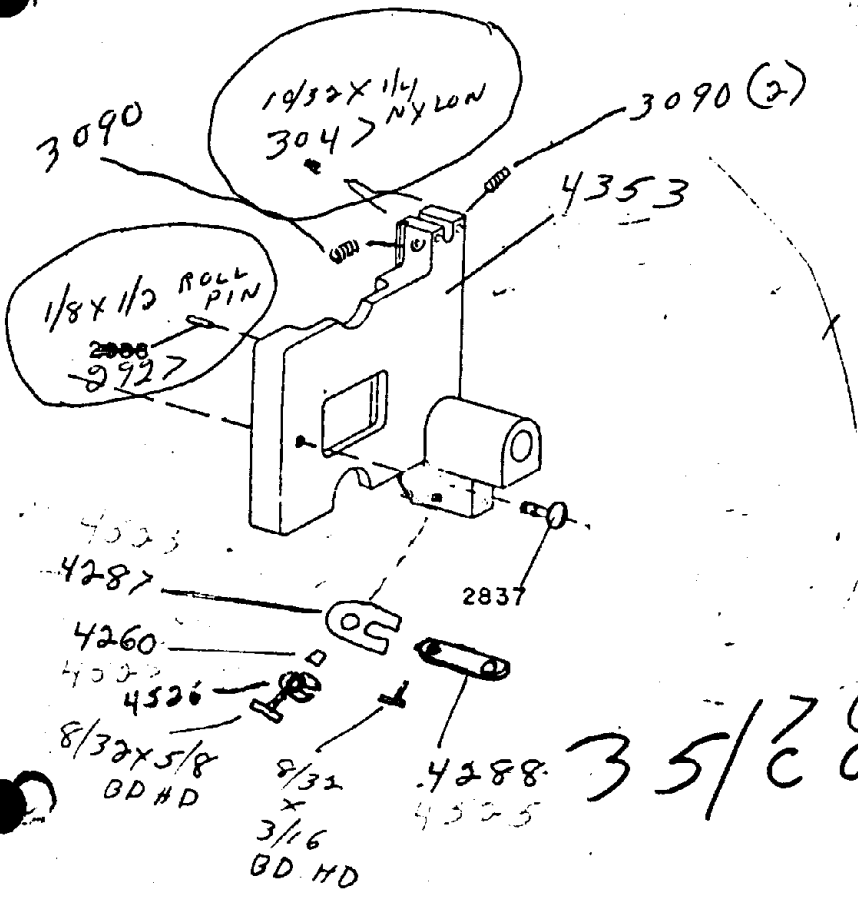

29-88-4A

35/70 CONV.