

# FILM-TECH

**THE INFORMATION CONTAINED IN THIS ADOBE ACROBAT PDF FILE IS PROVIDED AT YOUR OWN RISK AND GOOD JUDGMENT.**

**THESE MANUALS ARE DESIGNED TO FACILITATE THE EXCHANGE OF INFORMATION RELATED TO CINEMA PROJECTION AND FILM HANDLING, WITH NO WARRANTIES NOR OBLIGATIONS FROM THE AUTHORS, FOR QUALIFIED FIELD SERVICE ENGINEERS.**

**IF YOU ARE NOT A QUALIFIED TECHNICIAN, PLEASE MAKE NO ADJUSTMENTS TO ANYTHING YOU MAY READ ABOUT IN THESE ADOBE MANUAL DOWNLOADS.**

**[WWW.FILM-TECH.COM](http://WWW.FILM-TECH.COM)**



## Advanced Technology Analog Reader Instructions

### This Kit contains the following:

- (1) VISIBLE RED LED Assembly with Cable
- (1) Solar Cell and Lens Assembly
- (1) LED/Pre-Amp Integrated Power Supply

### Items required for Installation:

- Test Equipment: Real Time Analyzer  
Dual Trace Oscilloscope  
Multimeter
- Test Films: SMPTE Buzz Track  
Dolby® Cat. 69, 97 and 566

### Installation Instructions:

1. Remove the following items from the Soundhead:
  - a) Exciter Lamp Assembly and Optical Slit Lens
  - b) Solar Cell Assembly
2. Install the following items in the Soundhead:
  - a) LED Assembly in place of the Solar Cell Assembly

**IMPORTANT:** Place the LED as close as possible to the Film. This distance should be about .040"

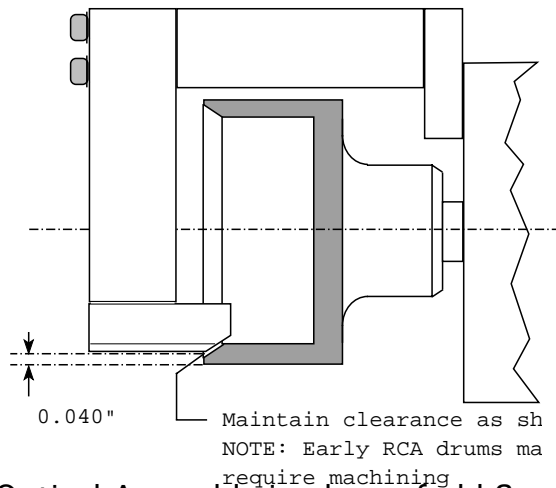

- b) Solar Cell and Optical Assembly in place of old Sound Lens.

See Page marked "Installation Notes" for your particular application

3. Mount the Integrated Power Supply in a convenient location; i.e., Console Bulkhead under Projector or in the Audio Rack.

4. Connect the Power Supply per the AT-1200-PS Block Diagram as shown in the following drawing.

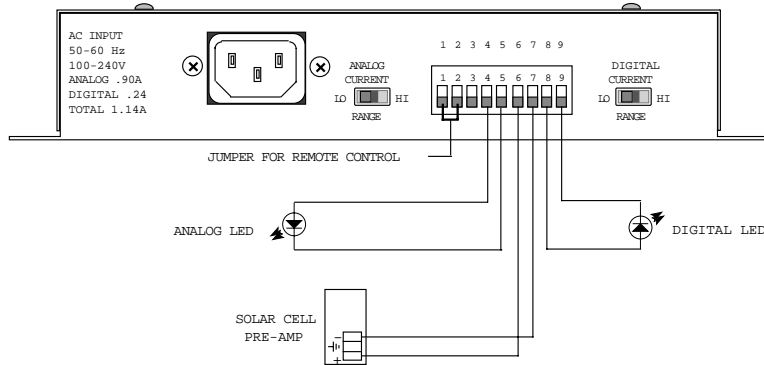

5. Connect the Solar Cell Pre-Amp Board to Sound Processor

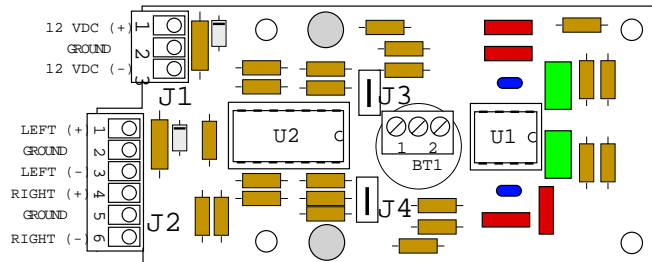

PLEASE NOTE THIS SYSTEM HAS BEEN FACTORY ALIGNED AND PERFORMANCE TESTED AND SHOULD ONLY REQUIRE MINIMAL ADJUSTMENT.

**Alignment:**

1. Preliminary

- a) Verify that the lens is clean.
- b) Verify that the LED is operational.
- c) Verify the Cell wiring for proper left/right wiring to Sound Processor.
- d) Set lens clearance to sound drum.

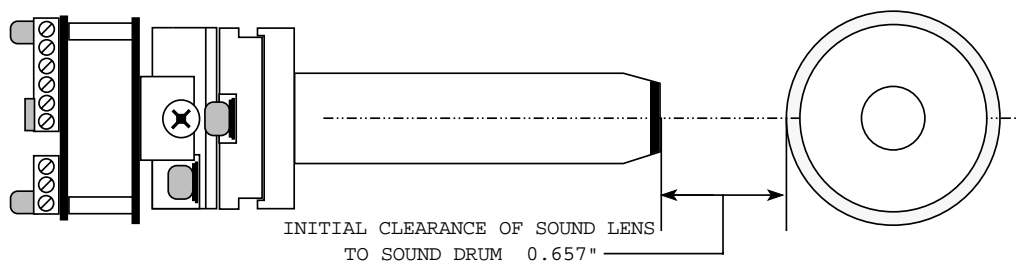

## 2. Primary

a) Set the initial LED operating current to 200 -210mA using a DC Current meter as out lined below.

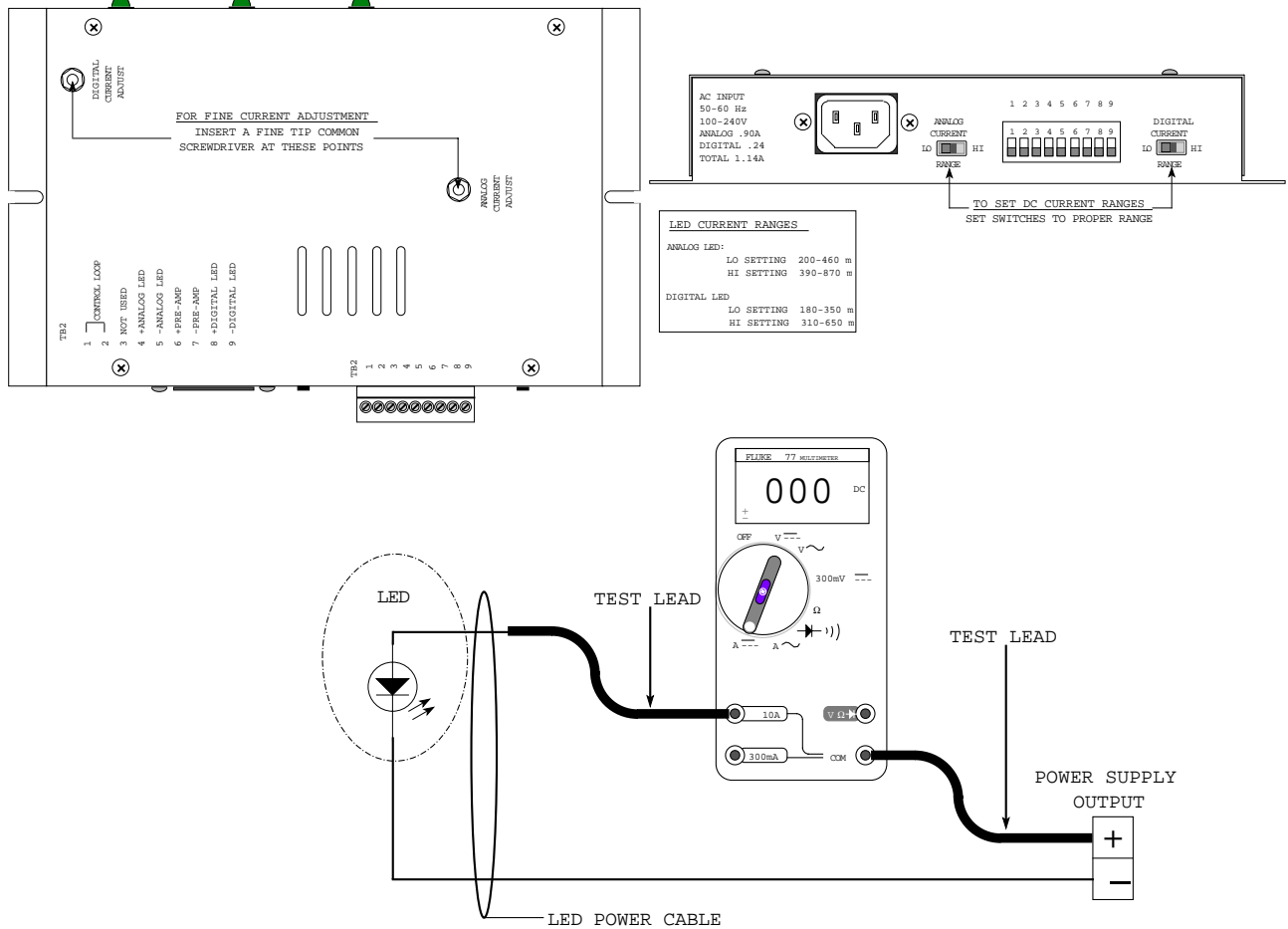

- On the Optical Pre-Amp of the Cinema Processor, turn all of the Proj.1 and Proj.2 GAIN potentiometers fully clockwise (cw) or to the maximum gain settings.
- On the Optical Pre-Amp of the Cinema Processor, turn all of the Proj.1 and Proj.2 HF potentiometers fully counterclockwise (ccw) or to the minimum gain settings.
- Set the Cinema Processor to Mono Optical Sound Format.
- Connect the RTA and Oscilloscope to the Left and Right Test Points of the Cinema Processor's Optical Pre-Amp. Ground both instruments to GND Point on this board.

f) Thread and play the Dolby tone side of the Cat.69 test film for an initial test of the signal path through the Projector Preamplifier. The film emulsion should face away from the screen. At this point, loosen the LED ARM mounting screws and move the arm up and down until you get the maximum output from the Solar Cell and tighten screws down. Adjust the Proj.1 and Proj.2 gain potentiometers until the Noise Reduction Modules meters indicate proper Dolby level. In addition, verify that the signal present LEDs on the Optical Pre-amp are lit. The Dolby tone should be present on the oscilloscope.

g) Remove the Cat.69 test film and thread the SMPTE Buzz Track test film. Adjust the lateral guide roller so that no signal is present on the oscilloscope. If necessary, the Solar Cell lateral position can be adjusted on the unit by loosening the Lateral Position Lock Screws, and then adjusting the Lateral Carrier. When adjustment is done, re-tighten the Lock Screw.

h) Remove the SMPTE Buzz Track test film then thread and play Dolby Cat.97 Stereo Cell Alignment Film. While the film is playing, look at the oscilloscope. If a large amount of crosstalk is present, move the lateral adjustment until the crosstalk both Left to Right and Right to Left are at a minimum and equal. You should be able to obtain better than 30dB of crosstalk (or better) rejection. Lock the adjustment in place.

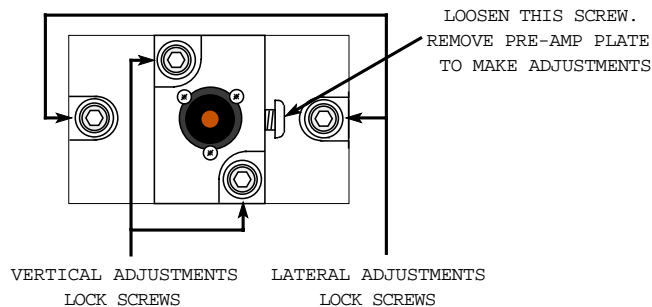

i) Verify that the outputs of the Pre-amp are properly connected. To do this, slowly insert a white card in front of the LED. As the card is inserted, the Right Channel should drop out first.

j) Remove the Cat.97 test film, then thread and play the Cat.69P test film (emulsion side away from the screen). Connect the RTA to the Left test point on the optical Pre-amp in the Cinema Processor. Switch the oscilloscope to the X/Y mode and adjust the azimuth of the Projector optics by rotating the assembly for the narrowest diagonal trace on the scope's display.

k) While observing the trace on the RTA, adjust the focus of the sound lens assembly for the best possible frequency response. The focus and azimuth may interact so after both the focus and azimuth have been set, tighten the lens clamp screw on the Soundhead.

l) Disconnect the RTA from the Left test point and connect to the Right test point and verify that the output is similar to that of the Left channel.

m) Reconnect the RTA to the Left channel. Adjust the Left hf potentiometer on the Optical pre-amp to obtain a frequency response that is flat within 1dB to at least 16kHz.

n) Repeat step 12 for the Right channel.

o) Remove the Cat.69 Test Film then thread and play Cat.566 Illumination Uniformity Test Film. Combine Left and Right channels on the Optical Pre-amp for a summed output to the RTA input. All 6 frequencies should be within .25dB of each other.

p) Remove the Cat.566 Test Film then thread and play Cat.69 Dolby Tone Test Film. Verify that the Optical Pre-amp is set at Dolby level.

q) Recheck Buzz Track, Cat.97 Crosstalk and Cat.69 Pink Noise.

If further assistance is required contact:

Kelmar Systems Inc.  
284 Broadway  
Huntington Station, NY 11746  
Phone 516-421-1230 FAX 516-421-1274

## Installation Notes

### Century Soundhead

To insure proper Lens tube travel for focusing of Solar Cell assembly, it may be necessary to remove some of the back portion of the Sound Lens Mounting Bracket Casting. This is due to excessive material in some models.

### Simplex Soundhead

Older model Soundheads that used a Bausch and Lomb Slit Lens Assembly having a O.D. of 0.750" will require shimming of the New Industry Standard Barrell whose O.D. is 0.747". Hard Paper or Cue Foil works well for this purpose.

### RCA Soundhead

A sleeve has been placed on the Lens Tube Assembly to increase its' O.D. so proper clamping may be achieved. Some older Sound Drums do not have a beveled outer flange, this must be corrected to obtain proper fit of the LED Bracket as shown in page 1 of these instructions.

## Installation Notes

### Century Soundhead

To insure proper Lens tube travel for focusing of Solar Cell assembly, it may be necessary to remove some of the back portion of the Sound Lens Mounting Bracket Casting. This is due to excessive material in some models.

### Simplex Soundhead

Older model Soundheads that used a Bausch and Lomb Slit Lens Assembly having a O.D. of 0.750" will require shimming of the New Industry Standard Barrell whose O.D. is 0.747". Hard Paper or Cue Foil works well for this purpose.

### RCA Soundhead

A sleeve has been placed on the Lens Tube Assembly to increase its' O.D. so proper clamping may be achieved. Some older Sound Drums do not have a beveled outer flange, this must be corrected to obtain proper fit of the LED Bracket as shown in page 1 of these instructions.

## Maintenance

Periodic Cleaning must be done to insure proper performance over the life of the system. Cleaning of the Lens can be done with plain Window cleaner and a cotton swab. Cleaning of the LED Should be done with a DRY cotton Swab.

### MAKE SURE THE SYSTEM IS OFF DURING CLEANING

LED Current Adjustment may have to be done periodically since the LED ages over time its' output may begin to decrease and Dolby level will not be achieved. To Adjust the current to the LED, refer to the following Diagram for the adjustment location and the following instructions captioned below. The system is shipped with the initial current is set at 200-210 Ma with a maximum output of 870 Ma. The Current reading must be done with a DC Current Meter. As shown on page 3 of these instructions.

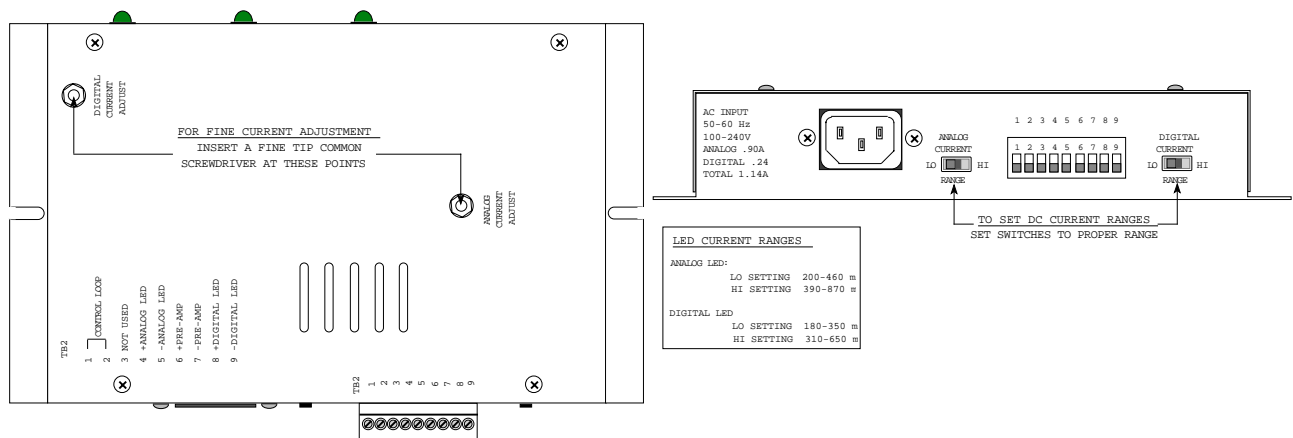

1. Set the gain adjustment on the Cinema Processor Optical Pre-Amp Board to maximum.
2. Thread and play Cat. No. 69T Dolby Tone Test Film.
3. Adjust the LED current so that the top (red) level indicators on the Cat. No. 222 Noise Reduction Module are illuminated (both channels).
4. Reduce the Pre-Amp gain until the bottom red LEDs are illuminated.
5. Adjust the current driving the reader LED until the two green Dolby Level indicators are equally illuminated on one or both channels.
6. If necessary, adjust the Pre-Amp gain on the other channel to indicate Dolby level for that channel.

If the LED output cannot produce enough signal to achieve Dolby level, then the LED is at the end of its useful life and should be replaced.



Avoid direct eye exposure to the LED beam. Do not attempt to view the LED beam with any type of optical device



## Reader Replacement Parts

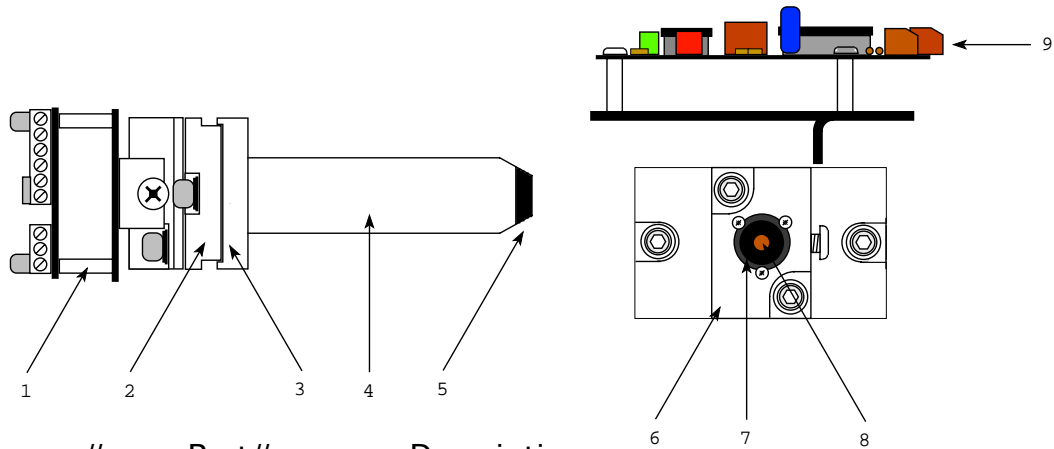

Diagram #	Part#	Description
1	9565	Pre-Amp Board Mounting Plate
2	AT-1246	Horizontal Slide
3	AT-1239-1	Main Base Plate
4	AT-1255	Lens Tube
5	AT-L1765	Lens
6	AT-1247	Vertical Slide
7	AT-1268	Solar Cell Retainer
8	AT-655-WM	Solar Cell W/Mask
9	PC-7929	Solar Cell Pre-Amp

## LED Replacement Parts

Part#	Description
AT-1174	Century LED Bracket Assembly
AT-1175	RCA LED Bracket Assembly
AT-1176	Simplex LED Bracket Assembly
AT-1187	Ballantyne VII LED Bracket Assembly
AT-1179	Cinemeccanica V5,V8 LED Bracket Assembly
AT-IRLED	Visible RED Replacement LED Only
AT-CALED	LED Cable Assembly

## Power Supply Replacement Parts

Part#	Description
AT-1200-PS	Complete Analog Power Supply
ATD-1200-PS	Complete Digital/Analog Power Supply
ATPS-5/12	Analog DC Power Supply Board Only
ATDPS-5	Digital LED DC Power Supply Board