

FILM-TECH

THE INFORMATION CONTAINED IN THIS ADOBE ACROBAT PDF FILE IS PROVIDED AT YOUR OWN RISK AND GOOD JUDGMENT.

THESE MANUALS ARE DESIGNED TO FACILITATE THE EXCHANGE OF INFORMATION RELATED TO CINEMA PROJECTION AND FILM HANDLING, WITH NO WARRANTIES NOR OBLIGATIONS FROM THE AUTHORS, FOR QUALIFIED FIELD SERVICE ENGINEERS.

IF YOU ARE NOT A QUALIFIED TECHNICIAN, PLEASE MAKE NO ADJUSTMENTS TO ANYTHING YOU MAY READ ABOUT IN THESE ADOBE MANUAL DOWNLOADS.

WWW.FILM-TECH.COM

englisch

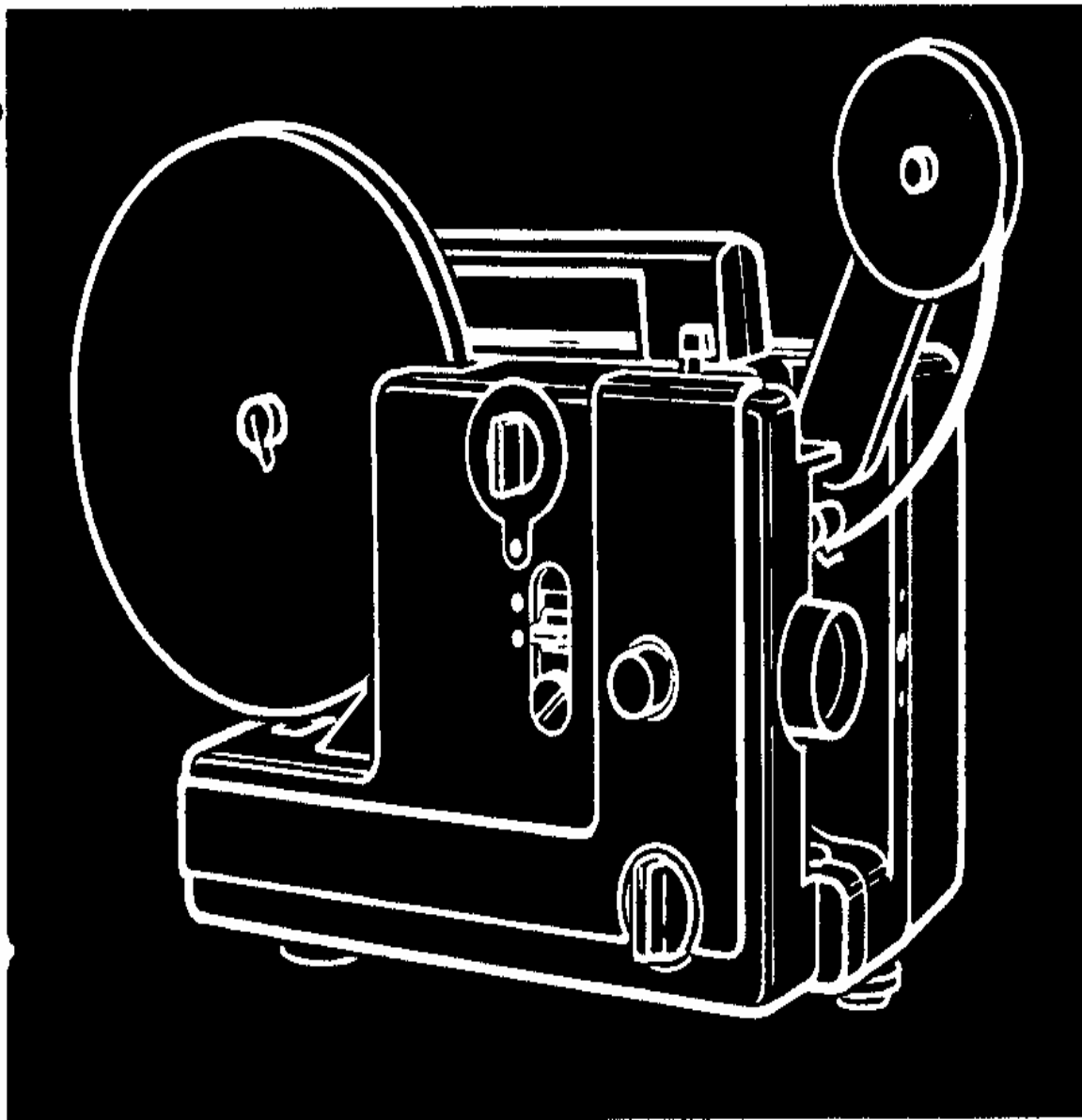

eumig

Instructions for use

624D/614D

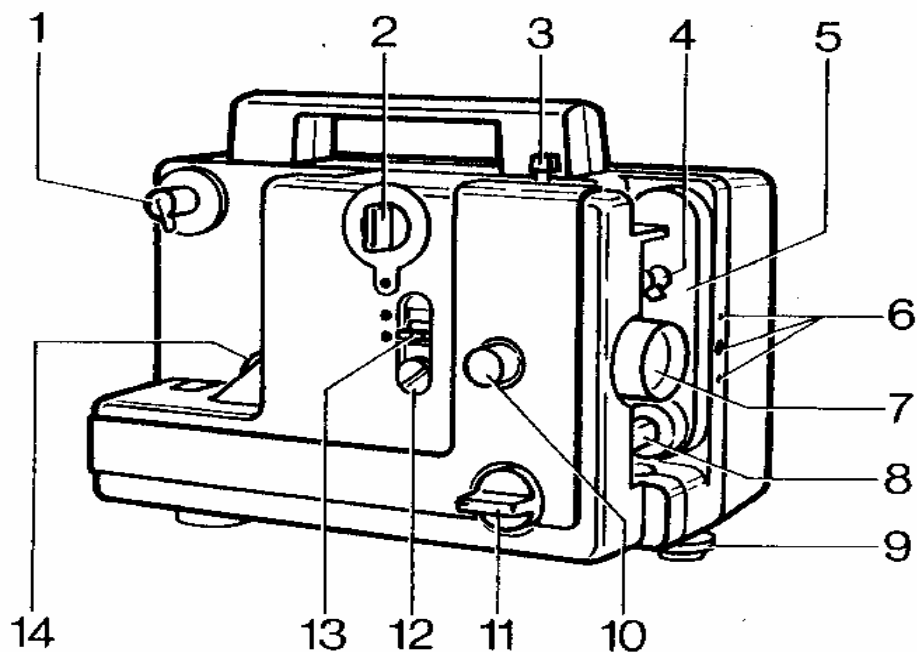

- | | |
|--|------------------------------------|
| 1 Reel shaft | 10 Focusing knob |
| 2 Slow motion knob | 11 Rotary selector switch |
| 3 Frame line lever | 12 Lamphouse cover screw |
| 4 Threading channel opening | 13 Film gauge lever |
| 5 Reel arm | 14 Pilot lamp (Model 624D) |
| 6 Mounting holes for daylight viewer (extra) | 15 Mains supply lead |
| 7 Lens | 16 Sound start socket (Model 624D) |
| 8 Feed reel shaft sleeve | 17 Voltage selector window |
| 9 Tilt control | 18 Fixing screws for back cover |

Accessories supplied with the projector

- 1 mains lead
- 1 guarantee card
- 1 Universal AS 18 reel, can be used as automatic take-up and library reel, No. 790.0320/5
- 1 reel shaft sleeve, No. 704.5710/4

Special accessories (Optional)

Folding case No. 790.0349/7

Protects the projector against dust during storage, also takes various accessories such as the mains lead, the empty reel etc.

Daylight viewer No. 790.0200/6

This is a valuable aid for previewing and editing films. A small monitor screen is mounted in front of the projector lens and secured with a milled screw. The ground glass screen shows a very bright projected image even in daylight.

Eumig sync-start lead (for Model 624D) No. 790.0267/5

To connect the projector to a cassette recorder with remote start provision.

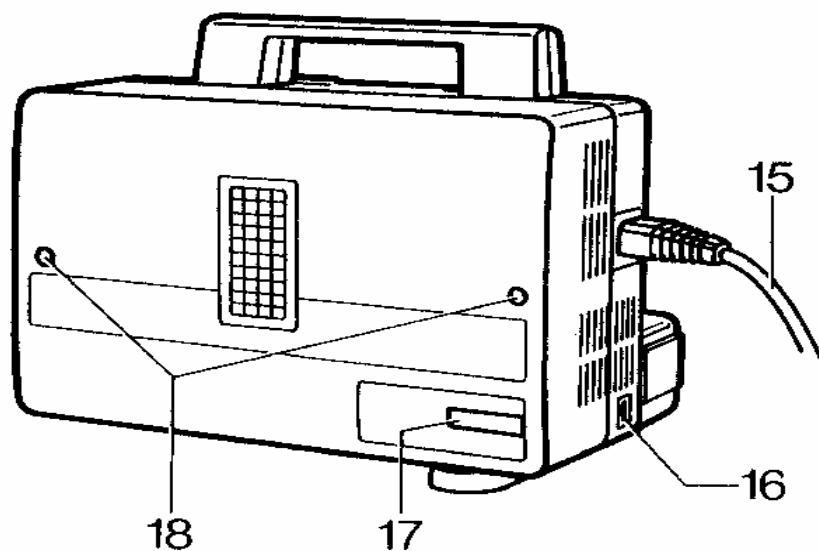

This product is manufactured to comply with the Radio Interference Requirements of EEC Directive 76/889/EEC.

IMPORTANT SAFEGUARDS

When using your projector, basic safety precautions should always be followed, including the following:

1. Read and understand all instructions.
2. Close supervision is necessary when any appliance is used by or near children. Do not leave appliance unattended while in use.
3. Care must be taken as burns can occur from touching hot parts.
4. Do not operate appliance with a damaged cord or if the appliance has been dropped or damaged – until it has been examined by a qualified serviceman.
5. Do not let cord hang over edge of table or counter or touch hot surfaces.
6. If an extension cord is necessary, a cord with a suitable current rating should be used. Cords rated for less amperage than the appliance may overheat. Care should be taken to arrange the cord so that it will not be tripped over or pulled.
7. Always unplug appliance from electrical outlet when not in use. Never yank cord to pull plug from outlet. Grasp plug and pull to disconnect.
8. Let appliance cool completely before putting away. Loop cord loosely around appliance when storing.
9. To protect against electrical shock hazards, do not immerse this appliance in water or other liquids.
10. To avoid electrical shock hazard, do not disassemble this appliance, but take it to a qualified serviceman when some service or repair work is required. Incorrect reassembly can cause electric shock hazard when the appliance is used subsequently.

SAVE THESE INSTRUCTIONS

VALID FOR UK ONLY!

This apparatus must be earthed.

The equipment should be disconnected from the mains when not in use.

Live parts inside – disconnect from mains before removing the cover.

Important: When operating the projector, do not obstruct the air stream emerging from the ventilation slots.

IMPORTANT: The wires in the mains lead are coloured in accordance with the following code:

Green-and-yellow:	Earth
Blue:	Neutral
Brown:	Live

As the colours of the wires in the mains lead of this apparatus may not correspond with the coloured markings identifying the terminals in your plug proceed as follows:

The wire which is coloured green-and-yellow must be connected to the terminal in the plug which is marked by the letter E or by the safety earth symbol  or coloured green or green-and-yellow.

The wire which is coloured blue must be connected to the terminal which is marked with the letter N or coloured black.

The wire which is coloured brown must be connected to the terminal which is marked with the letter L or coloured red.

The apparatus must be protected by a 3 A fuse if a 13 A (BS 1363) or another type of fused plug is used.

Before you start projecting

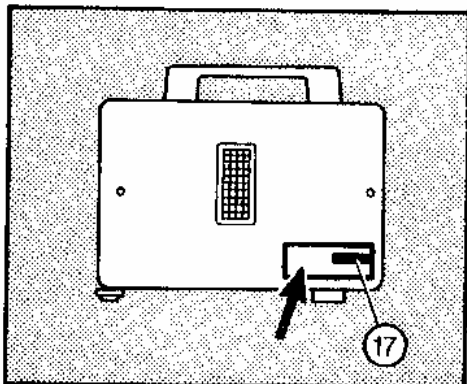

Checking the voltage

Check that the **type of current supply** (AC), **Mains frequency** (50 or 60 Hz) indicated on the data panel and the **voltage setting** visible in the window (17) match the values marked on your mains supply meter.

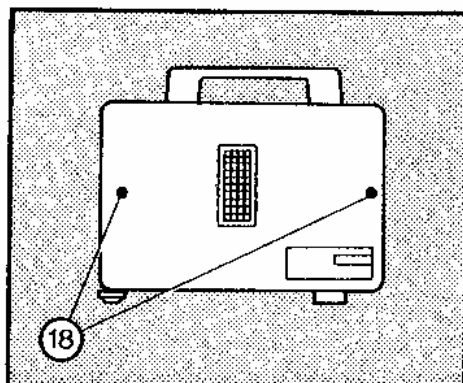

Changing the voltage

Only for the specialist

To change the voltage unscrew the fixing screws (18) and remove the back cover.

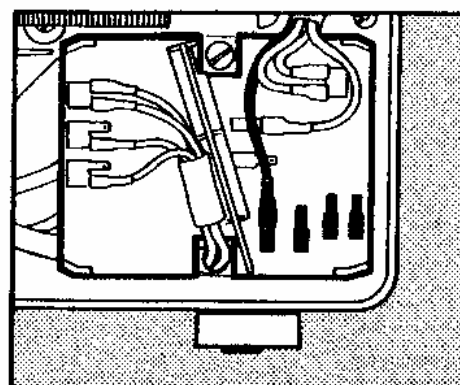

Unplug the red plug and push it on to the appropriate terminal. Then replace the back cover.

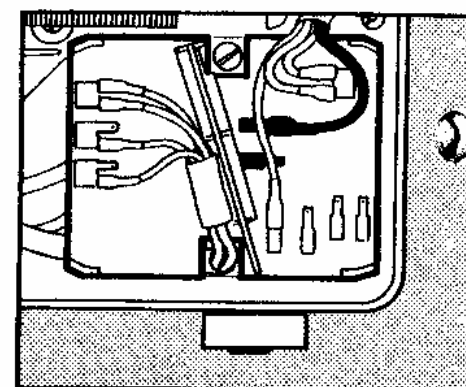

Changing the supply frequency

Only for the specialist

A version of this projector is available with a frequency adjustment for countries having different supply frequencies.

- Remove the back cover.
- Push the plug on the transformer on to the appropriate terminal (50 or 60 Hz).
- Place the drive belt into the correct groove (see sketch).
- Replace the back cover.

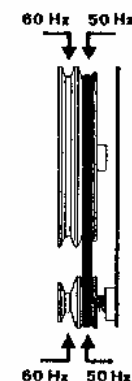

Preparing for projection

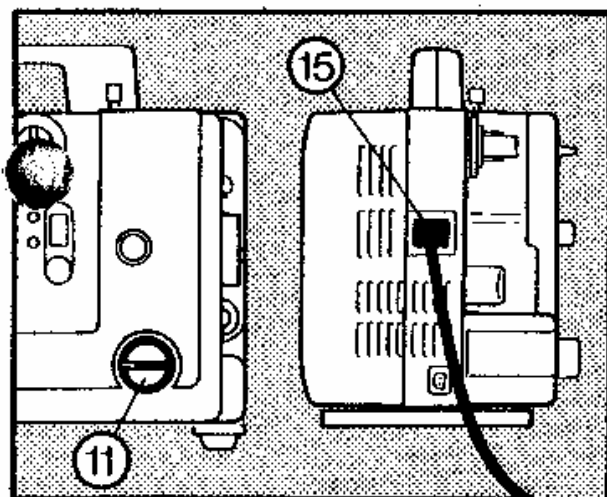

Connecting to the mains supply

- Check that the rotary selector switch (11) is set to its zero position.
- Connect the projector to the mains supply with the lead (15).

Important: When running the projector, do not obstruct the airstream through the ventilating slots.

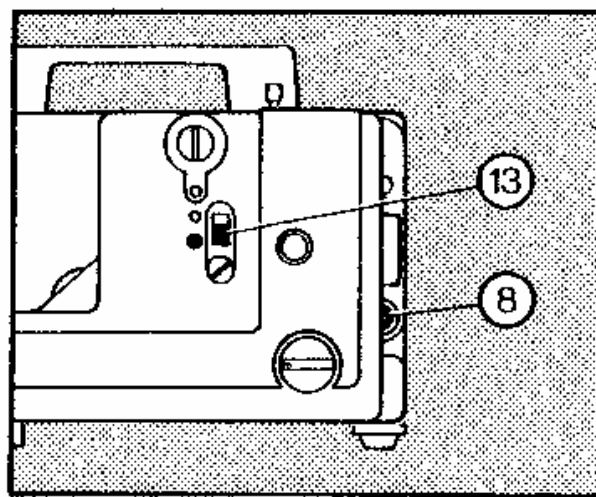

Selecting the film gauge

Super-8/Single-8

- Push down the gauge selector lever (13). (The blue signal lamp lights up during projection.)
- Leave the sleeve (8) on the reel shaft of the reel arm (5) — or fit it if not already there.

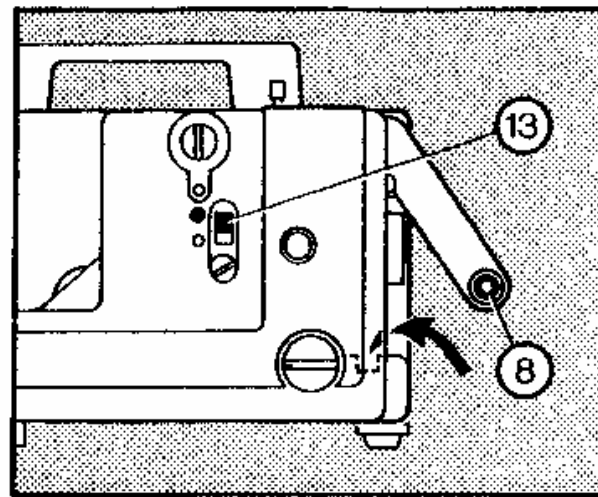

Standard 8

- Push the gauge selector lever (13) upwards. (The yellow signal lamp lights up during projection.)
- Remove the sleeve (8) from the reel shaft and place it in the storage hole provided (see arrow).



Running the show

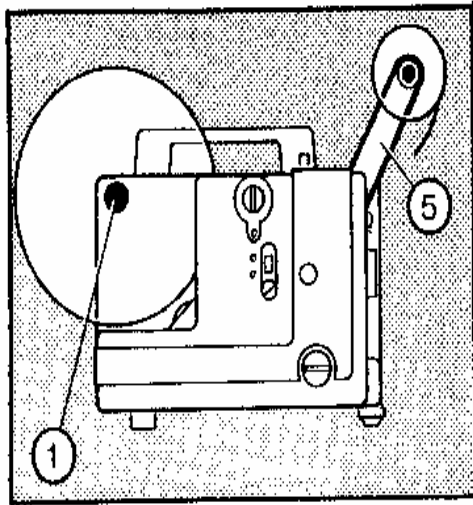

Fitting the reels

- Swing up the reel arm (5) to engage.
- Push the full reel on to the reel arm (5) and turn over the reel locks. The film perforations must be at the side facing you, in other words at the right when you look towards the screen. Rewind any wrongly spooled film first.
- Push the universal film reel supplied with the projector on to the take up reel shaft (1).

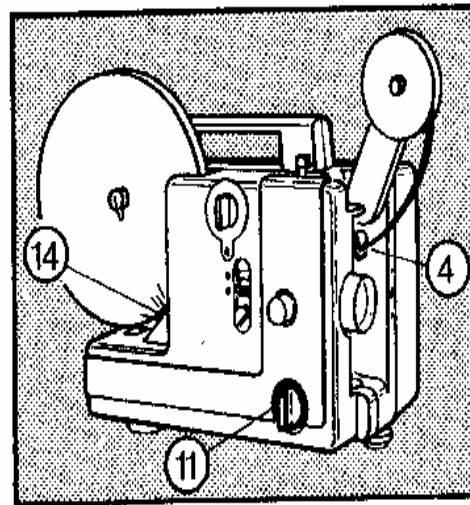

Threading

- Turn the rotary selector switch (11) to the threading position \gg . The pilot lamp (14) now lights up (Model 624 D only) and the projection lamp is being preheated.
- Push the film leader into the threading slot (4) until it is seized by the mechanism.

Threading then proceeds automatically through to the takeup reel.

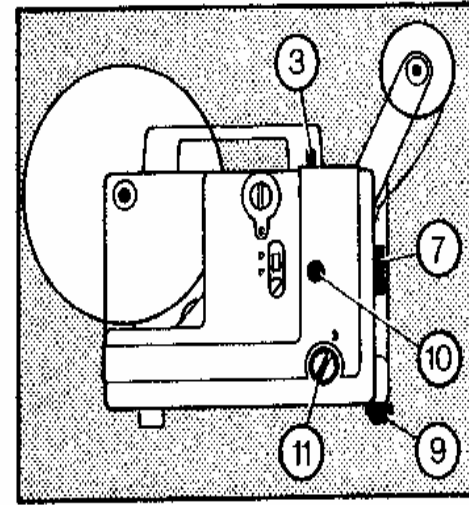

Forward projection

- Turn the rotary selector switch (11) to forward projection \gg .
- Turn the focusing knob (10) to bring the picture sharp on the screen.
- Adjust the image lever with the tilt control (9).
- Adjust the image size on the screen with the zooming ring on the lens (7).
- If necessary move the frame line lever (3) to make the image frame line disappear (dividing line between two frames).

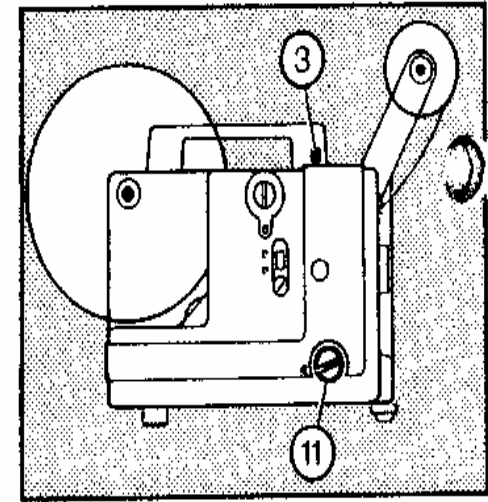

Reverse projection

- Turn the rotary selection switch (11) via the stop position to reverse projection \ll . The film now runs backwards and the action proceeds in reverse.
- You may have to readjust the frame line control (3).

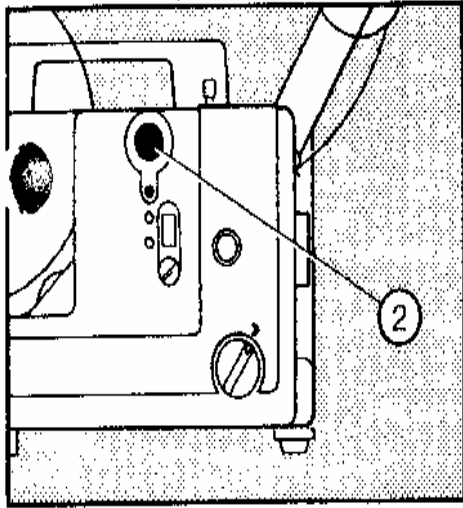

Slow motion and still picture projection

Slow motion: During projection (forward or reverse) turn the slow motion knob (2) to the running speed you want: 12, 9, 6, or 3 frames/second (9 or 6 frames/second with the model 614 D). This appropriately slows down the movement in the film.

Still picture projection: To project a stationary image turn the slow motion knob (2) to its zero position.

A green luminous dot shows the normal 18 fps speed.

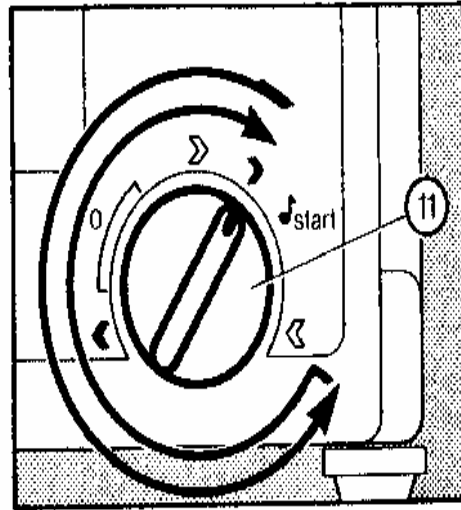

Back tracking

To repeat a section of the film, turn the rotary selector switch (11) to the left to reverse projection ◀ or rapid rewind ⏪, then to the right again to forward projection ▶.

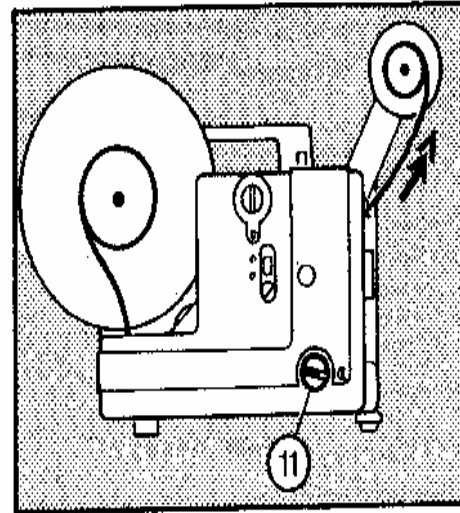

Rapid rewinding

Through the film channel: As soon as the film trailer enters the gate (and before the film leaves the feed reel) turn the rotary selector switch (11) to the left to rapid rewind ⏪. (This also opens the lens carrier so that the film channel is unobstructed. The projection lamp goes out at the same time.)

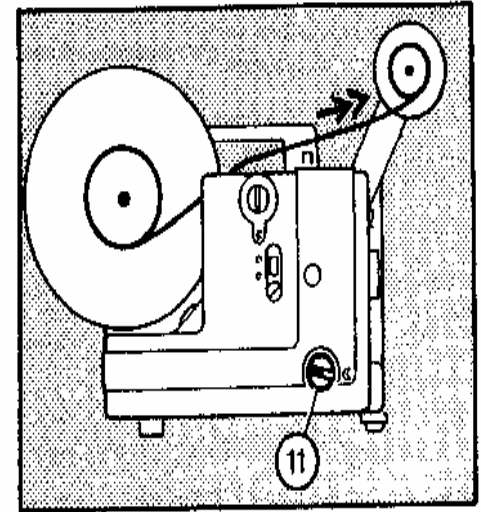

Direct reel-to-reel: If the end of the film has already run into the projector, let the film run through completely and then rewind externally:

- Attach the film end into the reel core at the front.
- Turn the rotary selector switch (11) to rapid rewind ⏪.

Sound with a cassette recorder (Model 624D)

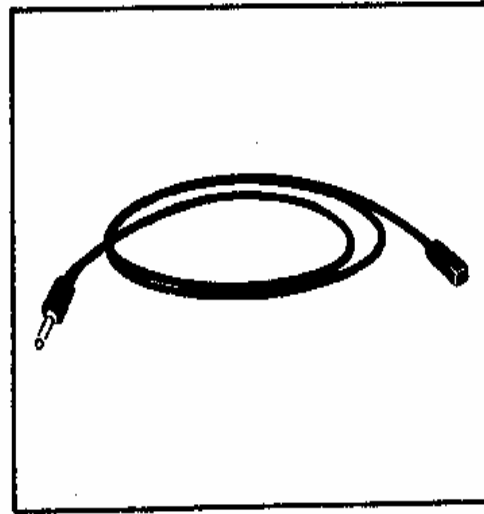

A start contact built into the projector allows a cassette recorder to be started and stopped by the projector. The cassette recorder must however have a remote control socket. Check the instruction book of your recorder.

The sync-start lead

Eumig has designed a special lead to start cassette recorders fitted with either a 2.5 mm remote control jack socket or a Phillips system DIN remote control socket. This lead is available from your photo dealer, Order No. 790.0267/5.

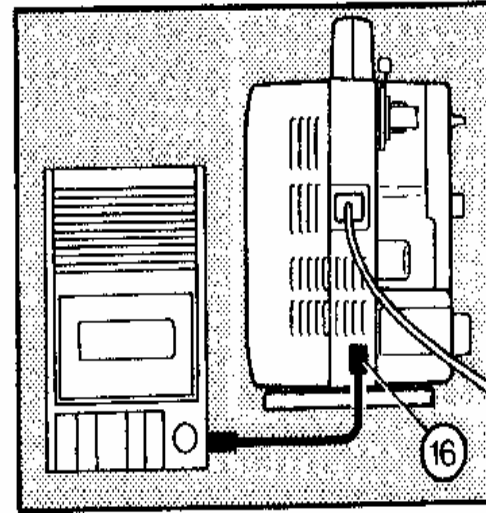

Connecting to the recorder

Use the sync-start lead to connect your cassette recorder to the sound start socket (16) on the projector.

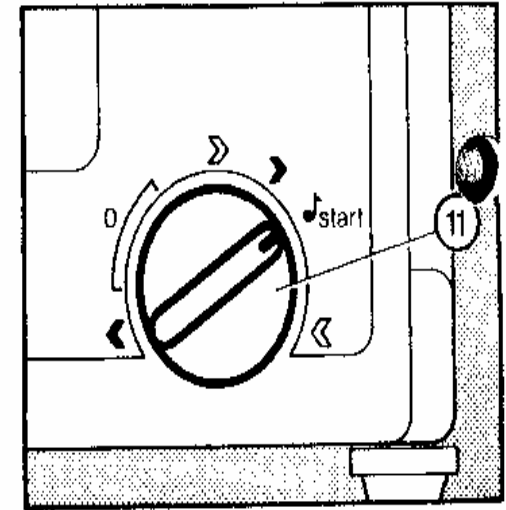

Starting the recorder

Turn the rotary selector switch (11) to the „♪ start“ position. Any other position of the switch stops the tape.

Correcting any image/sound separation

Sound is ahead: Briefly switch back to forward projection ►; that stops the tape.
Film is ahead: Briefly switch to 12 fps; the projector now runs more slowly.

Care of the projector

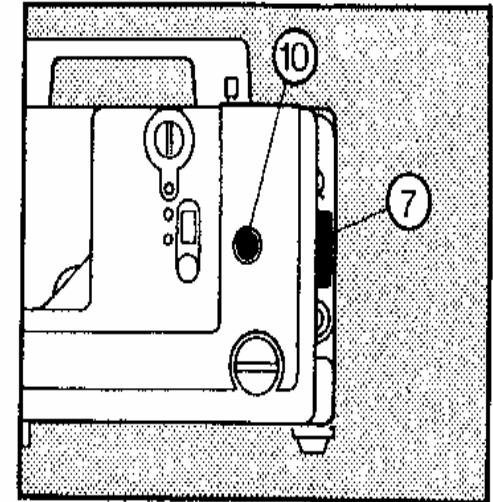
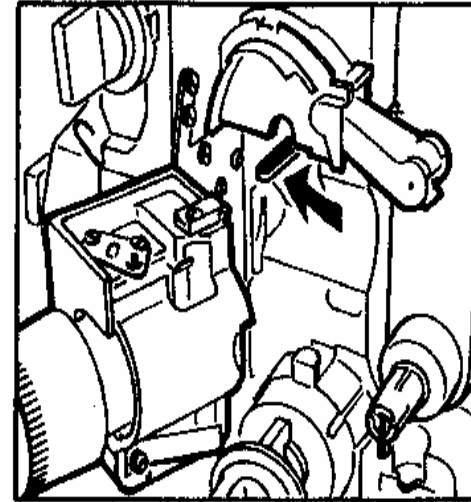
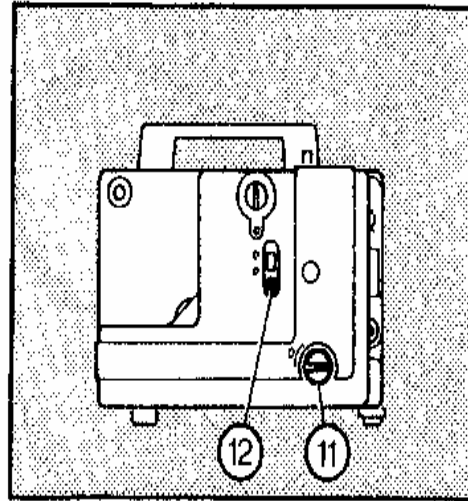

All moving parts of the projector are permanently lubricated and require no attention. Periodically clean the film guides and film channels carefully with a soft cloth or a camel hair brush to remove dust or film debris. On removing the lamphouse cover and opening the lens carrier, the film channel, film pressure pad and film guide are accessible for cleaning. Proceed as follows:

Cleaning the film channel

- **Disconnect the mains plug.**
- Turn the rotary selector switch (11) to its **upper** stop position.
- Unscrew the screw (12) with a coin and remove the lamphouse cover.

- Push the lens carrier lock to the left (arrow); the lens carrier swings open and the film channel is accessible for cleaning.

Cleaning the lens

- Turn the focusing knob (10) fully anticlockwise.
- Push the lens (7) into the projector and continue turning the focusing knob (10) anticlockwise.
- Now the lens can be removed and may be cleaned with a soft cloth or camel hair brush.

Before replacing the lens check that the engagement key of the lens faces you and that the focusing knob (10) is engaged. Now push the lens fully into the carrier and turn the focusing knob (10) clockwise.

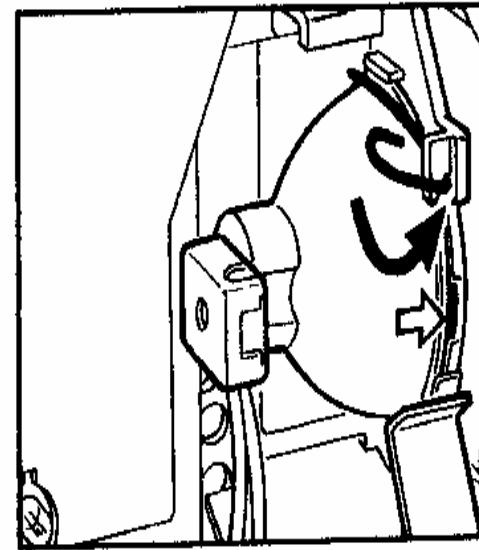
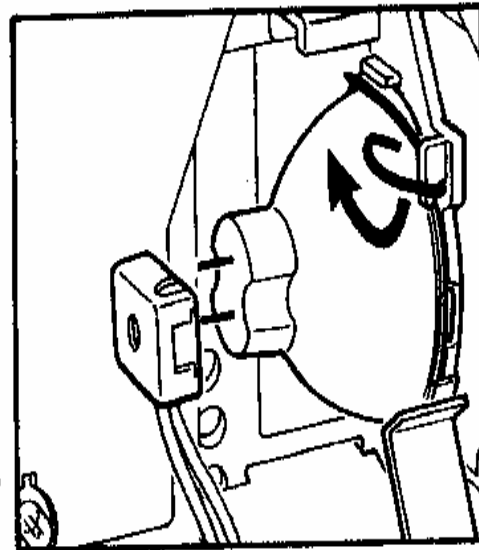
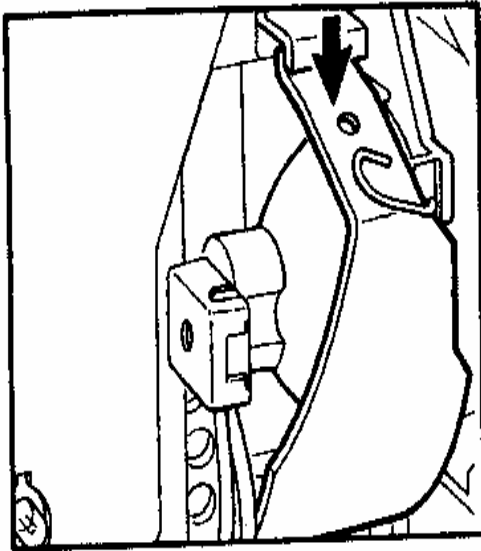

Changing the projection lamp

- Disconnect the mains plug.
- Unscrew the screw (12) with a coin and remove the lamphouse cover.
- Press down the top of the heat screen (arrow) to disengage it and swing down.

- Push down the lamp retaining spring to disengage and swing to the left.
- Remove the lamp and pull off the lamp socket.

Replacement lamp: 12 volt 100 watt tungsten-halogen lamp with diathermic reflector, Order No. 931004/6.

When inserting the new lamp take special care never to touch the bulb or the inside of the reflector with the bare fingers. (If you accidentally touch these areas, clean them with alcohol.)

- Push the lamp socket over the lamp contact pins.
- Raise the lamp retaining spring and locate the lamp in its fitting so that the centring key of the lamp engages the notch provided for it. Be careful not to pinch the lower spring when doing this.
- Engage the lamp retaining spring at the right.
- Re-engage the heat screen at the top.
- Replace the lamphouse cover.

In some supply areas an occasional overvoltage may cause the projection lamp to fail prematurely. In such a case set the voltage selector of the projector to the next higher voltage (for instance 230 volts instead of 220 volts; see page 2). This slightly reduces the light output but increases the burning life of the lamp.

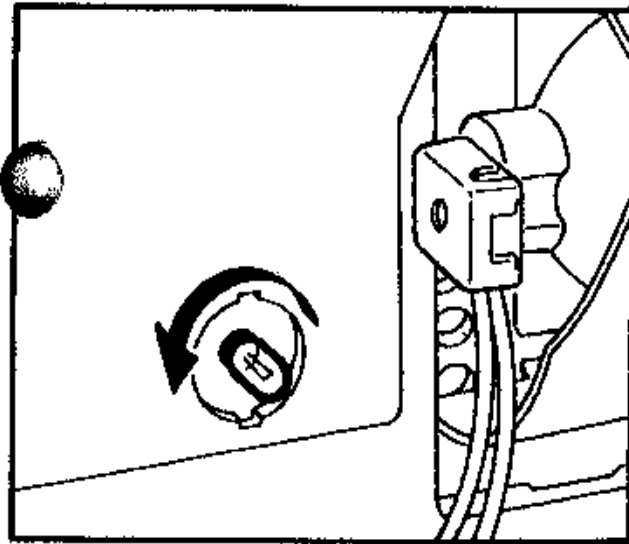

Changing the pilot lamp (Model 624 D)

- Disconnect the mains plug.
- Unscrew the fixing screw (12) and remove the lamphouse cover.
- Turn the small pilot lamp to remove, and replace by new 12 volt 3 watt lamp with Ba 95 bayonet fitting.
- Replace the lamphouse cover.

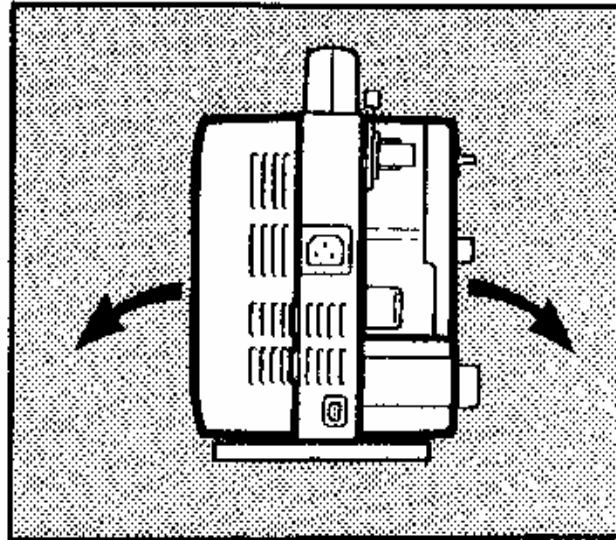

Replacing the drive belt

Only for the specialist

Order No. 731.5629/2

- Disconnect the mains plug.
- Set the rotary selector switch (11) to „Stop“ and the slow motion knob (12) to 18 fps.
- Remove the back cover as well as the lamphouse cover.

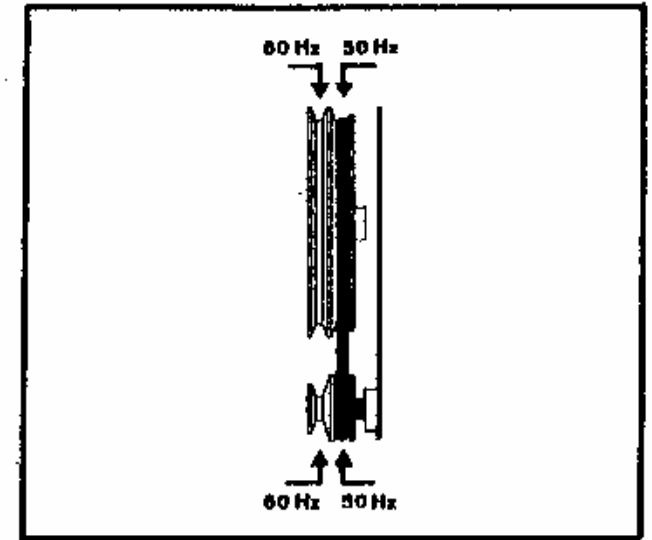

- Remove the faulty drive belt and place the new drive belt into the correct groove for the mains supply frequency.
- Replace the back cover and lamphouse cover.

Instructions in brief

