

# FILM-TECH

**THE INFORMATION CONTAINED IN THIS ADOBE ACROBAT PDF FILE IS PROVIDED AT YOUR OWN RISK AND GOOD JUDGMENT.**

**THESE MANUALS ARE DESIGNED TO FACILITATE THE EXCHANGE OF INFORMATION RELATED TO CINEMA PROJECTION AND FILM HANDLING, WITH NO WARRANTIES NOR OBLIGATIONS FROM THE AUTHORS, FOR QUALIFIED FIELD SERVICE ENGINEERS.**

**IF YOU ARE NOT A QUALIFIED TECHNICIAN, PLEASE MAKE NO ADJUSTMENTS TO ANYTHING YOU MAY READ ABOUT IN THESE ADOBE MANUAL DOWNLOADS.**

**[WWW.FILM-TECH.COM](http://WWW.FILM-TECH.COM)**

Price \$3.50



**SOUND SYSTEMS**

**PARTS CATALOGUE**

Manufactured by

**INTERNATIONAL PROJECTOR CORPORATION**

Bloomfield, N. J.

Distributed by

**NATIONAL THEATRE SUPPLY**

Subsidiaries of

General Precision Equipment Corporation

*Simplex* TRADEMARK REG. U. S. PAT. OFF.

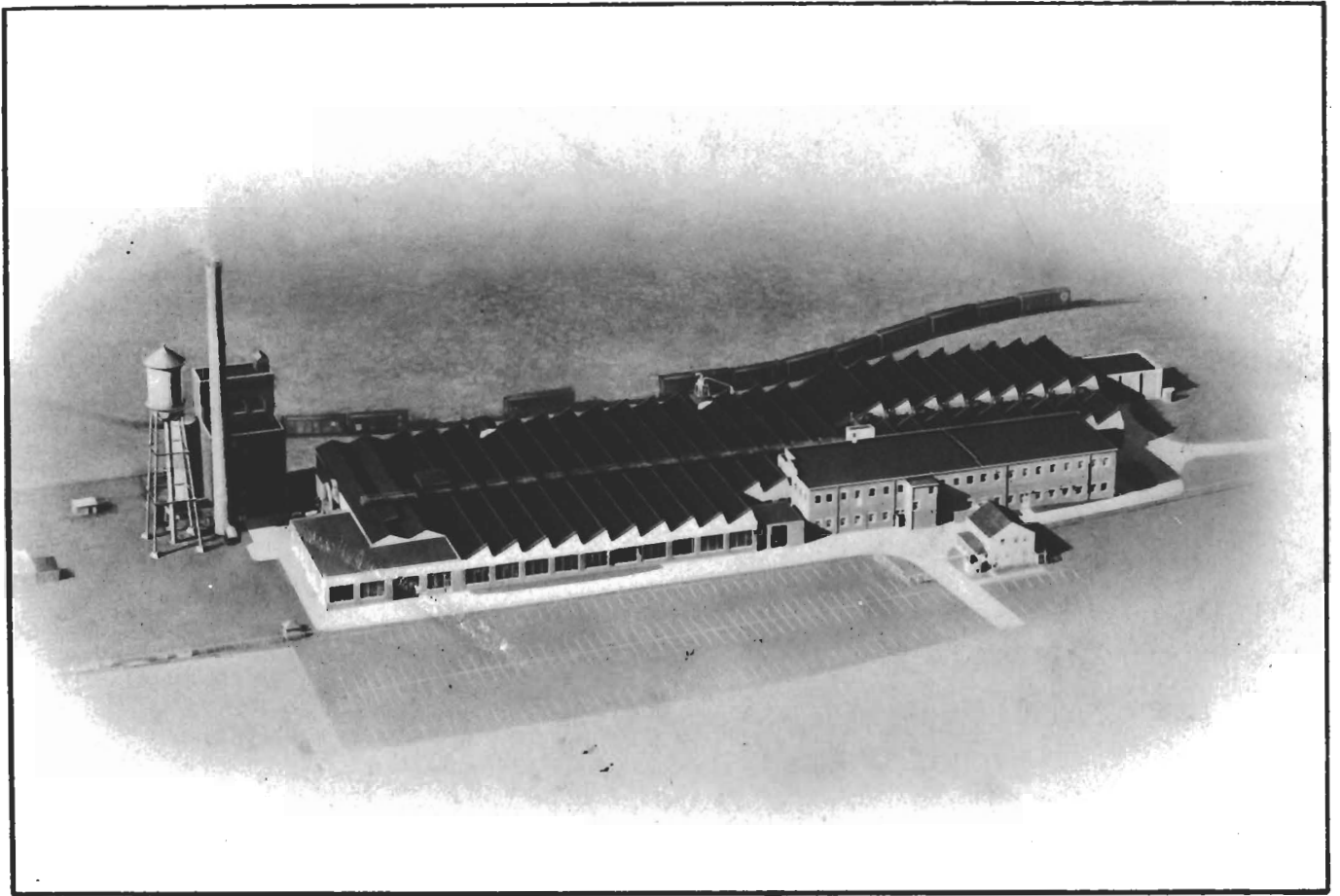

## HOME OF SIMPLEX EQUIPMENT

The newest, largest and most modern factory of the oldest manufacturer of standard, professional Motion Picture Projectors in the world. Here, there will continue to be originated and perfected, methods and standards that have given us an international leadership in the motion picture field for over forty years. A thoroughly progressive spirit enables us to give theatre owners the highest possible value at the lowest possible cost. No other firm has facilities that are at all comparable for the economical and efficient manufacture of motion picture equipment and parts.

*Simplex* service supplements *Simplex* quality. Exhibitors know they can rely upon *Simplex* distributors for satisfactory installation of *Simplex* equipment, for advice and help when emergencies arise and for prompt delivery of *GENUINE SIMPLEX PARTS* when needed. *GENUINE SIMPLEX PARTS* always give the greatest value and are absolutely essential for best results with *SIMPLEX PROJECTORS*.



# *Safeguard your most Valuable Assets*

- HIGH QUALITY SOUND
- PLEASSED PATRONS

WHY BE SATISFIED WITH ANYTHING BUT THE BEST! GENUINE *Simplex* PARTS, FROM THE MANUFACTURER OF THE FAMOUS *Simplex* X-L SOUND SYSTEMS SAFEGUARD THE PERFORMANCE OF YOUR *Simplex* EQUIPMENT, ASSURING CONTINUED HIGH QUALITY SOUND AND EXTRAORDINARY DEPENDABILITY.

# I N D E X

## SECTION I

	<i>Page</i>
AM-197 Changeover Cabinet .....	1-0
AM-202 Changeover and Warping Cabinet .....	1-2
AM-203 Changeover Cabinet .....	1-4
AM-205 Remote Switch Box .....	1-6
AM-207 System Selector Box .....	1-8
AM-211 Four Channel Changeover Cabinet .....	1-10
AM-212 Balance-Warping Cabinet .....	1-12
AM-213 System Selector and Control Cabinet .....	1-14

## SECTION II

AM-1026 Power Amplifier .....	2-0
AM-1027 Power Amplifier .....	2-2
AM-1028 PEC Amplifier .....	2-4
AM-1029 Monitor Amplifier .....	2-18, 3-2
AM-1031 System Cabinet .....	2-6
AM-1032 System Cabinet Kit .....	2-8
AM-1033 System Cabinet Kit .....	2-9
AM-1034 System Cabinet .....	2-10
AM-1035 Non-Synch. Cabinet .....	2-12
AM-1037 Cabinet Kit .....	2-14
AM-1038 Cabinet Kit .....	2-15
AM-1039 Cabinet Kit .....	2-16
AM-1050 Cabinet Kit .....	2-17
AM-1054 Monitor Amplifier and Control Panel .....	2-18
AM-1055 Cabinet Kit .....	2-20
AM-1059 Cabinet Kit .....	2-21
AM-1060 PEC Amplifier Cabinet .....	2-22
AM-1062 Monitor Panel and System Cabinet Kit .....	2-24
AM-1064 Control Unit .....	2-26
AM-1065 Pre-Amplifier .....	2-28
AM-1066 Pre-Amplifier Cabinet .....	2-30
AM-1079 Warping Unit .....	2-32
AM-1081 Monitor Control Panel .....	2-34
*AM-1089 System Control Cabinet .....	2-42
AM-1150 Control Unit .....	2-36
AM-1151 Cabinet Kit .....	2-40

## SECTION III

LU-142 Monitor Speaker .....	3-0
LU-1103 Network .....	3-2
LU-1122 Speaker Switch Kit .....	3-4
LU-1177 3 Speaker Optical Switch Kit .....	3-6
LU-3017 Monitor Selector-Ramp Control Panel .....	3-8
LU-3018 Amplifier Selector-Ramp Control Panel .....	3-10

## SECTION IV

PU-1005 Power Unit .....	4-1
PU-1008 Power Supply .....	4-2

\* Numerical List Of Parts For AM-1089 On Page 7—7

**Insert in 1955 Edition of  
Simplex XL Sound Parts Catalog.**

	Page
PU-1009 Power Unit (60 cycles).....	4-4
PU-1010 Power Unit (50 cycles).....	4-4
PU-1011 Pre-Amplifier Power Supply .....	4-6
PU-1012 Power Supply Cabinet .....	4-8
PU-1013 Power Supply Dummy Load .....	4-10
**PU-1014 Power Supply Cabinet .....	4-9

**SECTION V**

SH-1007 Sound Mechanism (60 cycles) .....	5-0
SH-1008 Sound Mechanism (50 cycles) .....	5-0
SH-1009 Motor Assembly (60 cycles) .....	5-2
SH-1010 Motor Assembly (50 cycles) .....	5-2
SH-1011 Sound Mechanism Accessory Kit .....	5-4
SH-1012 Sound Mechanism (Drive-In, 60 cycles) .....	5-0
SH-1013 Sound Mechanism (Drive-In, 50 cycles) .....	5-0
SH-1020 Sound Mechanism (60 cycles) .....	5-4
SH-1021 Sound Mechanism (50 cycles) .....	5-4
SH-1022 Sound Mechanism Accessory Kit .....	5-6
SH-1025 Magnetic Soundhead .....	5-8 thru 5-17
Film Compartment and Door Parts .....	5-8
Flywheel Compartment and Cover Parts .....	5-10
Terminal Strip Compartment and Cover Parts .....	5-13
Magnetic Pickup Head and Mounting Parts (Current Type) .....	5-16
Magnetic Pickup Head and Mounting Parts (First Type) .....	5-17
Upper and Lower Drum and Associated Parts .....	5-15
Upper and Lower Tension Roller Parts .....	5-14
SH-1026 Magnetic Soundhead .....	5-8 thru 5-16
Film Compartment and Door Parts .....	5-8
Flywheel Compartment and Cover Parts .....	5-10
Terminal Strip Compartment and Cover Parts .....	5-12
Magnetic Pickup Head and Mounting Parts (Current Type) .....	5-16
Upper and Lower Drum and Associated Parts .....	5-15
Upper and Lower Tension Roller Parts .....	5-14

**SECTION VI**

G-1962 Gear Box Assembly (60 cycles) .....	6-1
G-1974 Lens Assembly .....	6-4
G-1977 Lateral Guide Roller .....	6-5
G-1981 Photocell Bracket .....	6-6
G-1982 Lens Reflector .....	6-6
G-1983 Sound Bracket .....	6-7
G-2010 Exciter Lamp Bracket .....	6-10
G-2078 Exciter Lamp Bracket .....	6-12
G-2080 Exciter Lamp Base .....	6-12
G-2125 Gear Box Assembly (50 cycles) .....	6-1
G-2141 Sound Bracket .....	6-7

**SECTION VII**

Numerical List of Parts .....	7-0 thru 7-6
**Numerical List of Parts for PU-1014 on Page 7-7	

# SECTION I

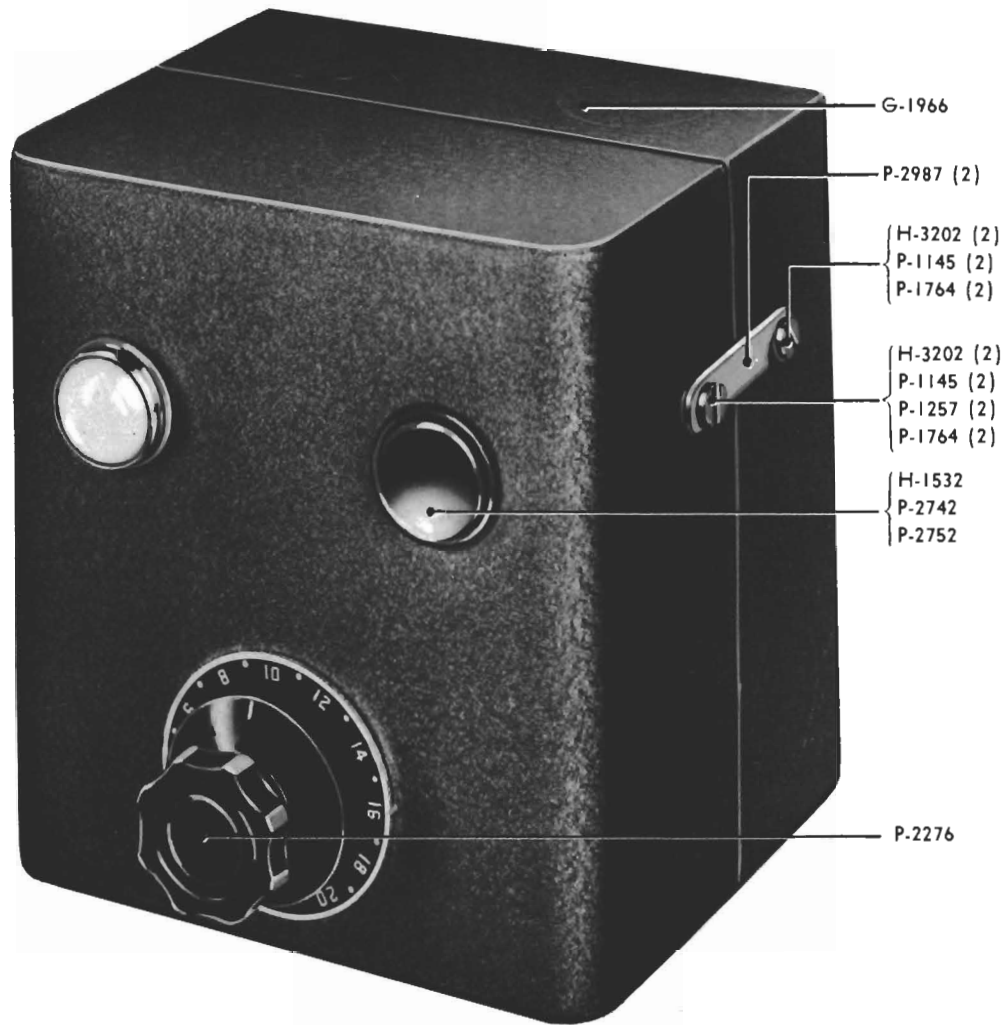

## AM-197 CHANGEOVER CABINET

G-1940	Terminal Strip	P-1257	Cabinet Link Screw Washer (2)
G-1966	Cabinet and Door (Includes H-3202 (4), P-1145 (4), P-1257 (2), P-1764 (4), P-2987 (2))	P-1278	Terminal Strip-Cable Clamp Lockwasher (5)
G-2119	Cable Form	P-1764	Cabinet Link Screw (4) (Included with G-1966)
H-1532	Changeover Switch Knob Set Screw	P-1859	Changeover Switch Fastening Nut
H-2716	Terminal Strip-Cable Lamp Fastening Screw (5)	P-2099	Capacitor, .1 mf, 400 V
H-3202	Cabinet Link Screw Fastening Nut (4) (Included with G-1966)	P-2264	Pilot Light Socket
H-3226	Cable Clamp Fastening Nut	P-2276	Volume Control, Dial Plate, Knobs and Nuts
H-3442	Changeover Switch Lockwasher	P-2425	Pilot Light, 6-8 V
		P-2679	Changeover Switch
		P-2742	Changeover Switch Knob
		P-2752	Changeover Switch Knob Spring
		P-2987	Cabinet Link (2) (Included with G-1966)
P-1145	Cabinet Link Screw Lockwasher (4) (Included with G-1966)	P-2999	Cable Clamp



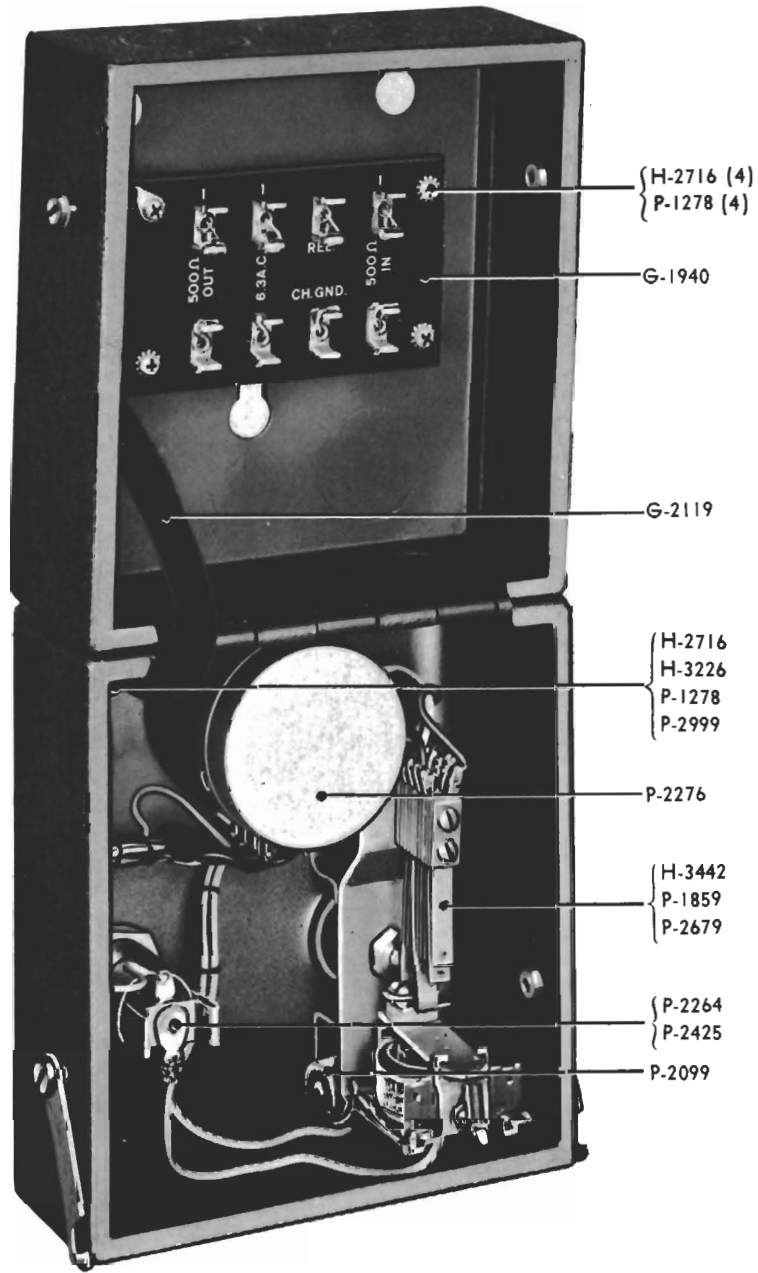

AM-197 CHANGEOVER CABINET

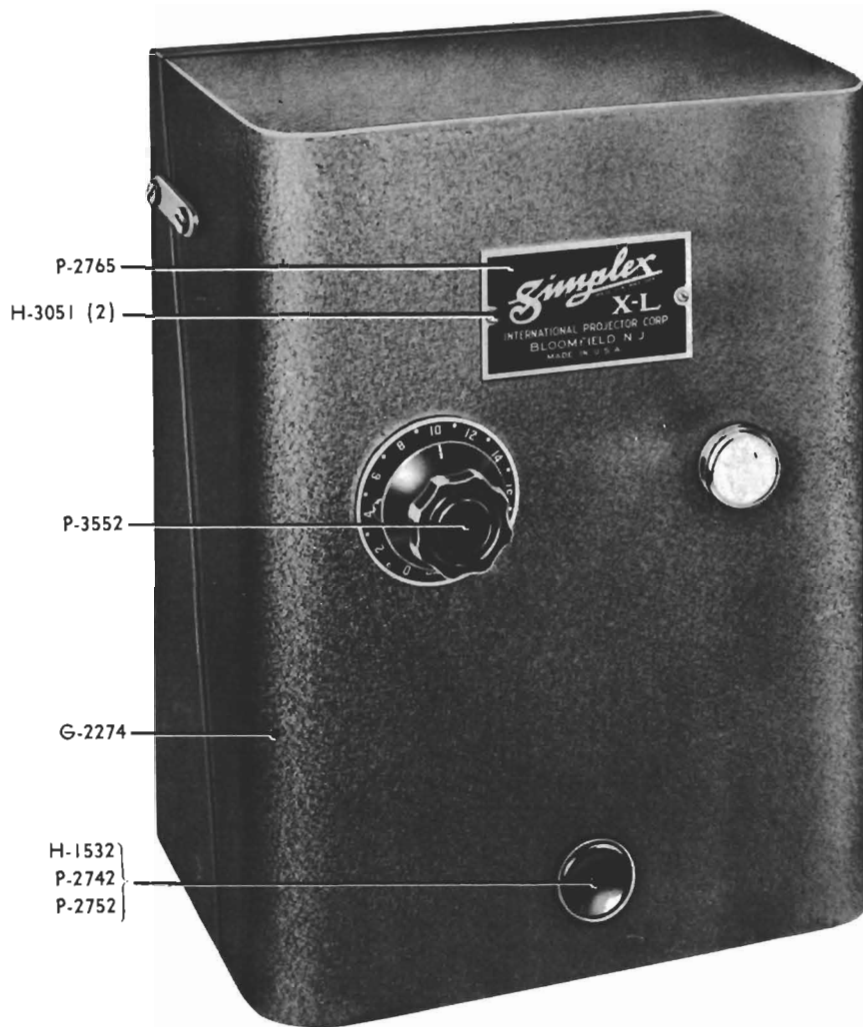

## AM-202 CHANGEOVER AND WARPING CABINET

G-2273	Cable Form	P-1278	Terminal Strip-Cable Clamp
G-2274	Cabinet (Includes H-3051 (2), H-3202 (4), P-1145 (4), P-1257 (2), P-1764 (4), P-2765, P-2987 (2))	P-1764	Lockwasher (8)
G-2286	Terminal Strip	P-1859	Cabinet Link Screw (4)
G-2292	Resistor Mounting Strip and Lugs	P-2051	(Included with G-2274)
H-1532	Changeover Switch Knob	P-2075	Changeover Switch Fastening Nut
H-2716	Fastening Screw	*P-2099	Resistor, 1 K, 1 Watt (3)
H-3051	Terminal Strip-Cable Clamp	P-2264	Resistor, 470 Ohms, 1 Watt (3)
H-3202	Fastening Screw (8)	P-2425	Capacitor, 0.1 mf, 400 V (7)
H-3226	Nameplate Fastening Screw (2)	P-2742	Pilot Light Socket
H-3442	(Included with G-2274)	P-2752	Pilot Light, 6-8 V
P-1145	Cabinet Link Screw Fastening	P-2765	Changeover Switch Knob
P-1257	Nut (4) (Included with G-2274)	P-2872	Changeover Switch Knob Spring
	Cable Clamp Fastening Nut	*P-2873	Nameplate (Included with G-2274)
	Changeover Switch Lockwasher	P-2875	Capacitor, 0.03 mf, 400 V (6)
		P-2876	Capacitor, 0.15 mf, 400 V (6)
		P-2987	Resistor, 270 Ohms, 1 Watt (3)
			Resistor, 120 Ohms, 1 Watt (6)
			Cabinet Link (2) (Included with G-2274)
		P-2999	Cable Clamp
		P-3192	Changeover Switch
		P-3552	Volume Control, Dial Plate, Knob and Screws

\* Shipped separately with AM-202 as alternate parts for attenuating and warping networks. Only (6) P-2099 are included with this separate shipment.

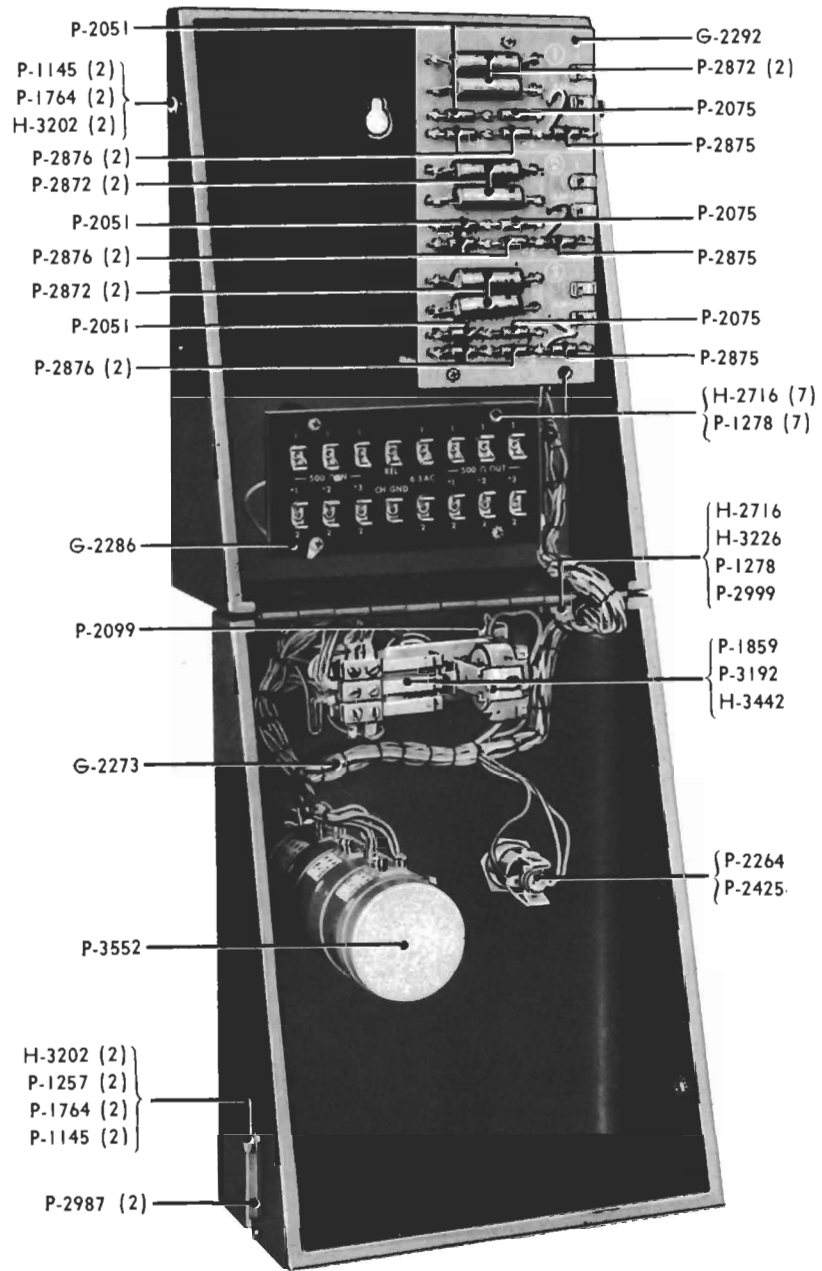

AM-202 CHANGEOVER AND WARPING CABINET

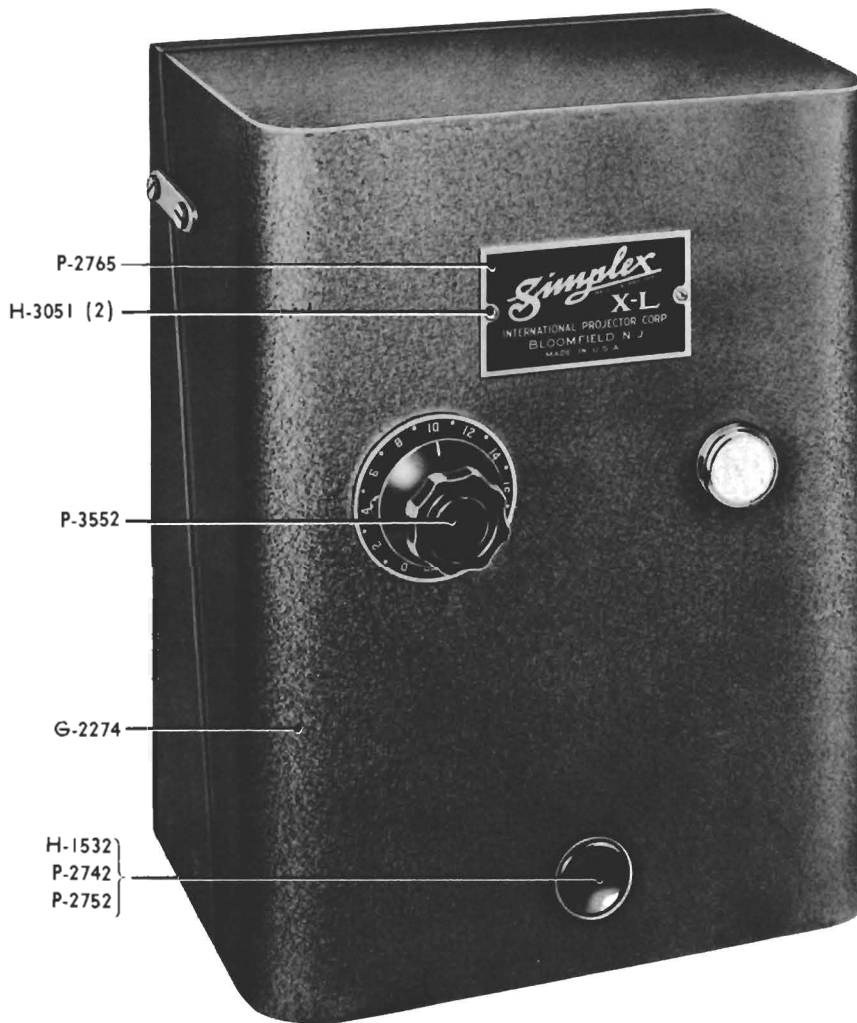

### AM-203 CHANGEOVER CABINET

G-2274	Cabinet (Includes H-3051 (2), H-3202 (4), P-1145 (4), P-1257 (2), P-1764 (4), P-2765, P-2987 (2))	P-1257	Cabinet Link Screw Washer (2) (Included with G-2274)
G-2286	Terminal Strip	P-1278	Terminal Strip-Cable Clamp Lockwasher (5)
G-2298	Cable Form	P-1764	Cabinet Link Screw (4) (Included with G-2274)
H-1532	Changeover Switch Knob Fastening Screw	P-1859	Changeover Switch Fastening Nut
H-2716	Terminal Strip-Cable Form Fastening Screw (5)	P-2099	Capacitor, 0.1 mf, 400 V
H-3051	Nameplate Fastening Screw (2) (Included with G-2274)	P-2264	Pilot Light Socket
H-3202	Cabinet Link Screw Fastening Nut (4) (Included with G-2274)	P-2425	Pilot Light, 6-8 V
H-3226	Cable Clamp Fastening Nut	P-2742	Changeover Switch Knob
H-3442	Changeover Switch Lockwasher	P-2752	Changeover Switch Knob Spring
P-1145	Cabinet Link Screw Lockwasher (4) (Included with G-2274)	P-2765	Nameplate (Included with G-2274)
		P-2987	Cabinet Link (2) (Included with G-2274)
		P-2999	Cable Clamp
		P-3192	Changeover Switch
		P-3552	Volume Control, Dial Plate, Knob and Screws

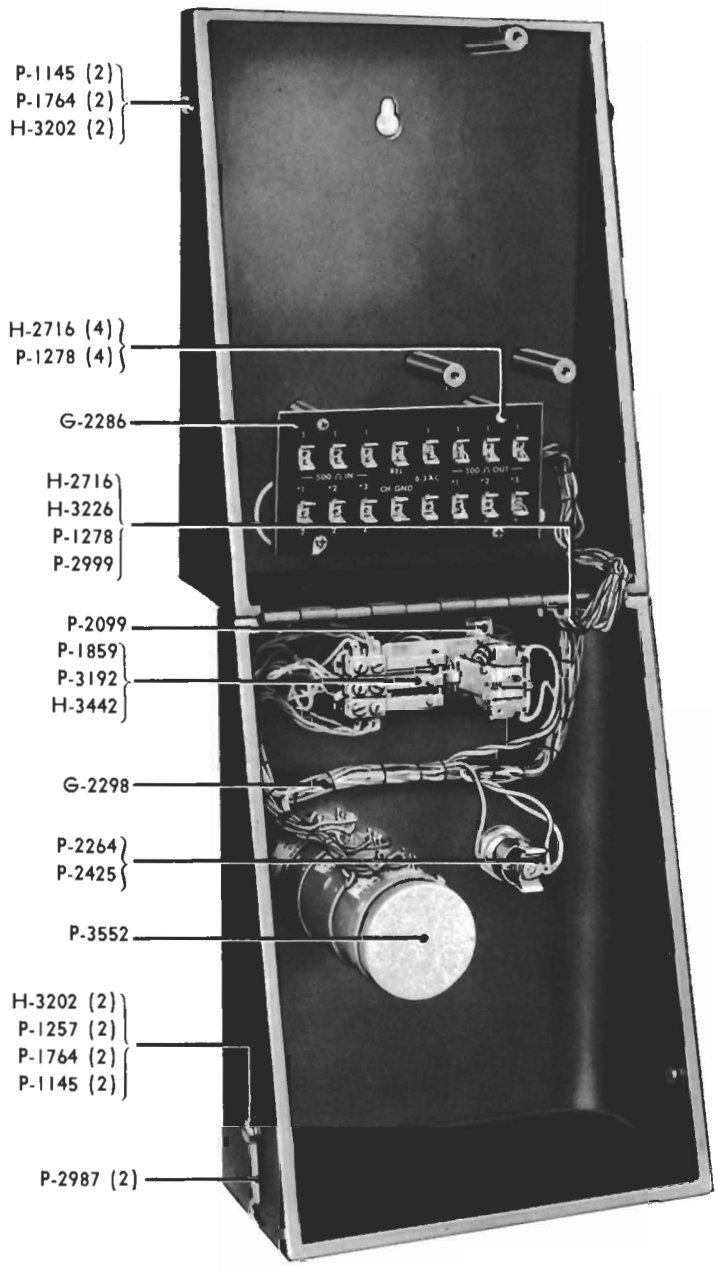

AM-203 CHANGEOVER CABINET



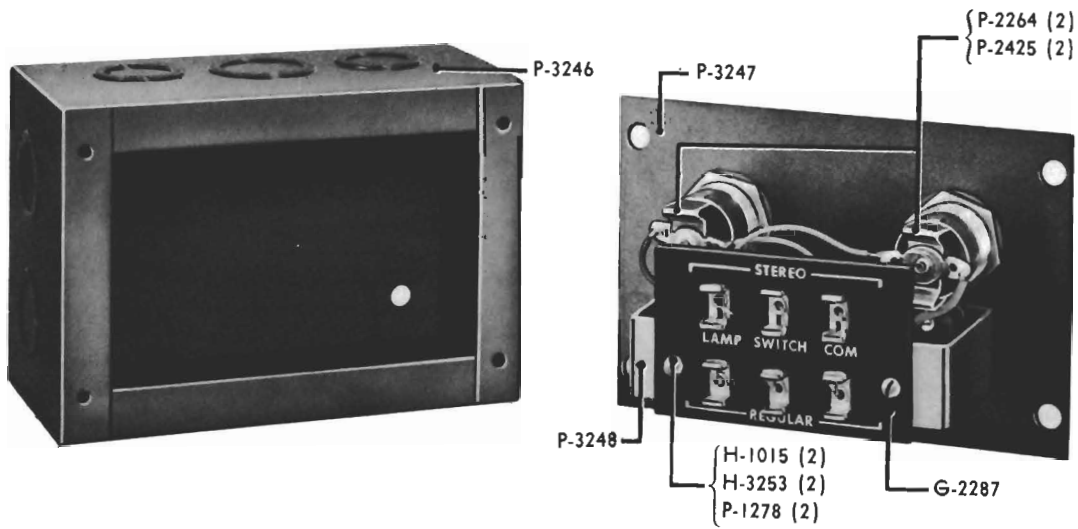

AM-205 REMOTE SWITCH BOX

## AM-205 REMOTE SWITCH BOX

G-2287	Terminal Strip
H-1015	Terminal Strip Fastening Screw (2)
H-3244	Regular-Stereo Switch Fastening Nut (4) ((2) included with each P-3245)
H-3253	Terminal Strip Fastening Nut (2)
H-4901	Front Panel Fastening Screw (4)
P-1278	Terminal Strip Lockwasher (2)
P-2264	Pilot Light Socket (2)
P-2425	Pilot Light, 6-8 V (2)
P-3245	Regular-Stereo Switch (Includes (2) H-3244 with each Switch)
P-3246	Switch Box
P-3247	Front Panel
P-3248	Terminal Strip Mounting Bracket

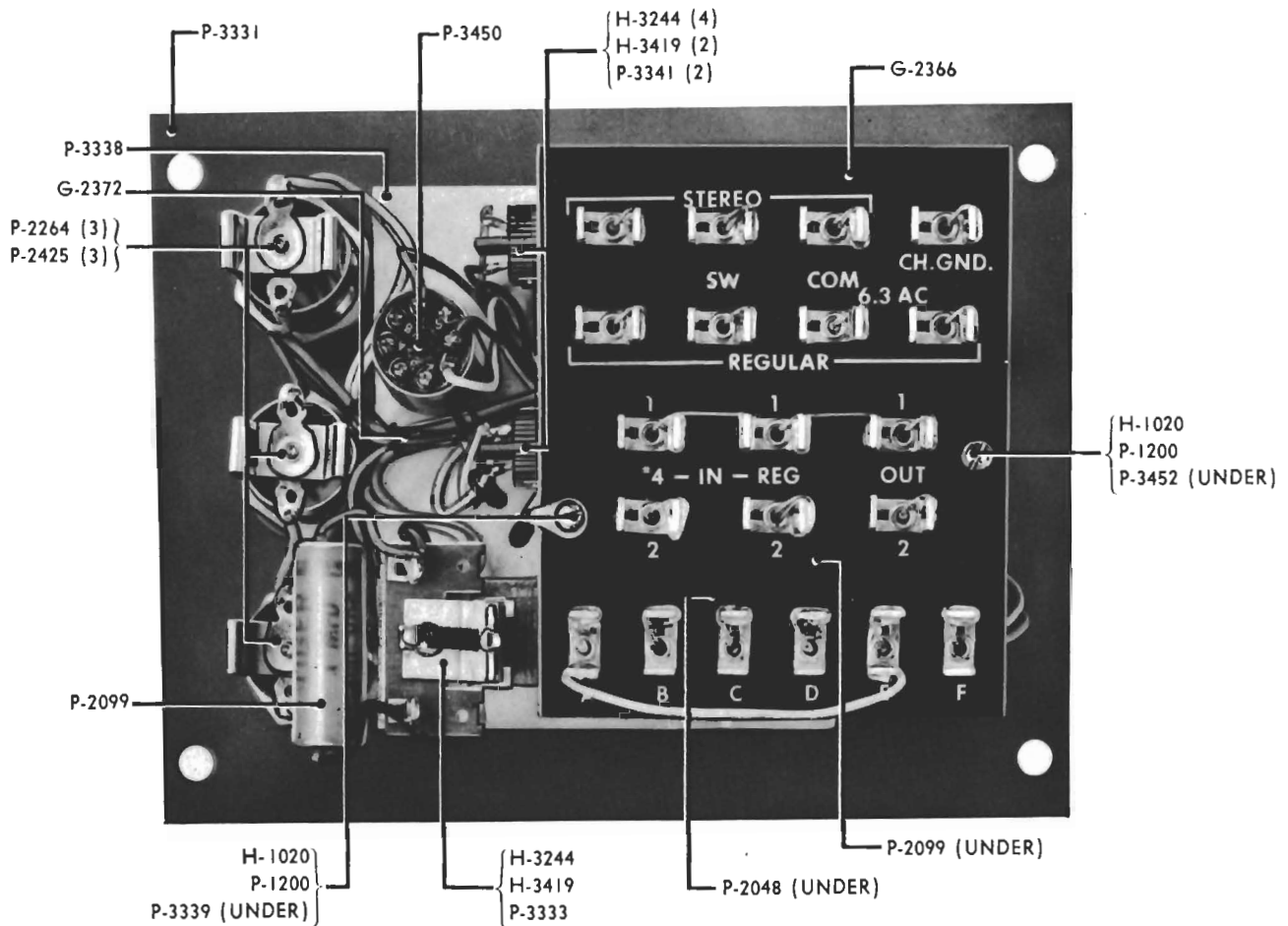
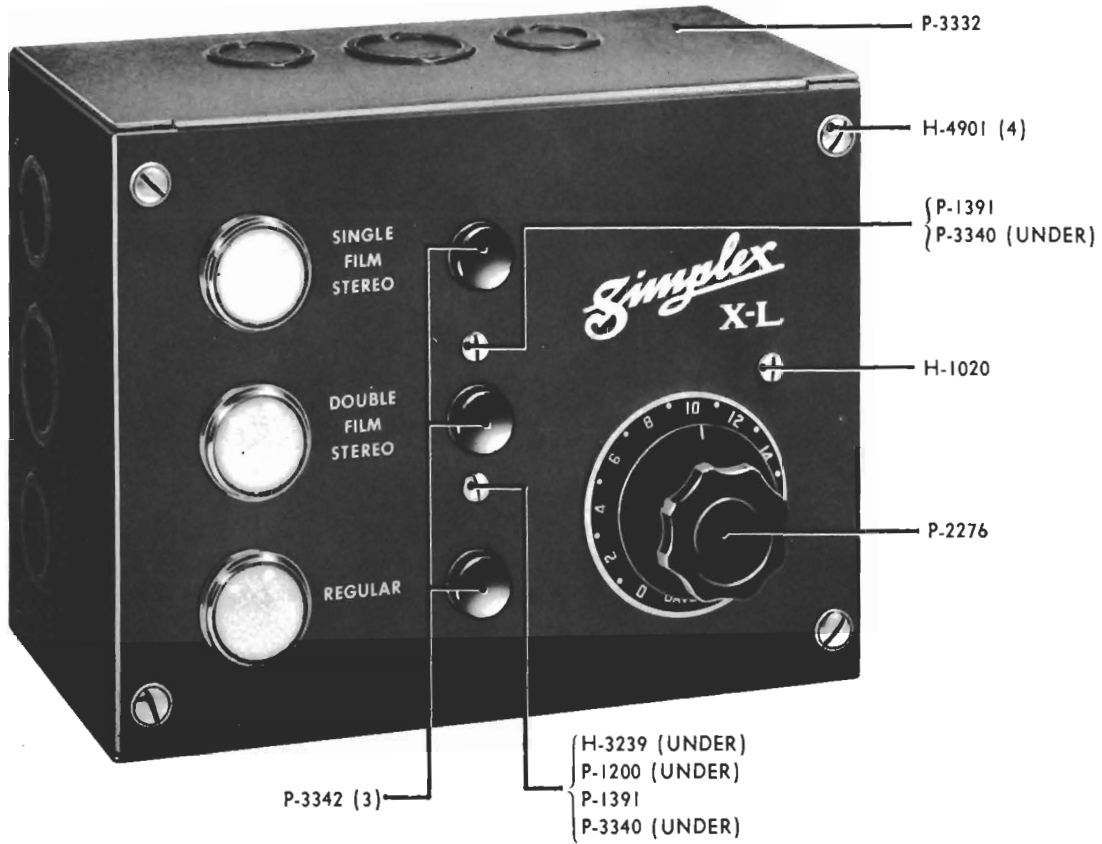

AM-207 SYSTEM SELECTOR BOX

## AM-207 SYSTEM SELECTOR BOX

G-2366	Terminal Strip
G-2372	Cable Form
H-1020	Terminal Strip-Mounting Stud Fastening Screw (3)
H-3239	Transformer Mounting Plate Fastening Nut
H-3244	Regular-Double Film Stereo-Changeover Switch Fastening Nut (5)
H-3419	Regular-Double Film Stereo-Changeover Switch Lockwasher (3)
H-4901	Front Panel Fastening Screw (4)
P-1200	Transformer Mounting Plate-Terminal Strip Lockwasher (3)
P-1391	Transformer Mounting Plate-Terminal Strip Lower Mounting Stud Fastening Screw (2)
P-2048	Resistor, 1 Meg., 1 Watt
P-2099	Capacitor, 0.1 mf, 400 V (2)
P-2264	Pilot Light Socket (3)
P-2276	Volume Control, Dial Plate, Knob and Nuts
P-2425	Pilot Light, 6-8 V (3)
P-3331	Front Panel
P-3332	Box
P-3333	Changeover Switch (Includes P-3342)
P-3338	Transformer Mounting Plate
P-3339	Terminal Strip Upper Mounting Stud
P-3340	Transformer Mounting Plate-Terminal Strip Lower Mounting Stud (2)
P-3341	Regular-Double Film Stereo Switch (2) (Includes P-3342 with each P-3341)
P-3342	Changeover-Regular-Double Film Stereo Switch Knob (3)
P-3450	Transformer
P-3452	Terminal Strip Mounting Stud

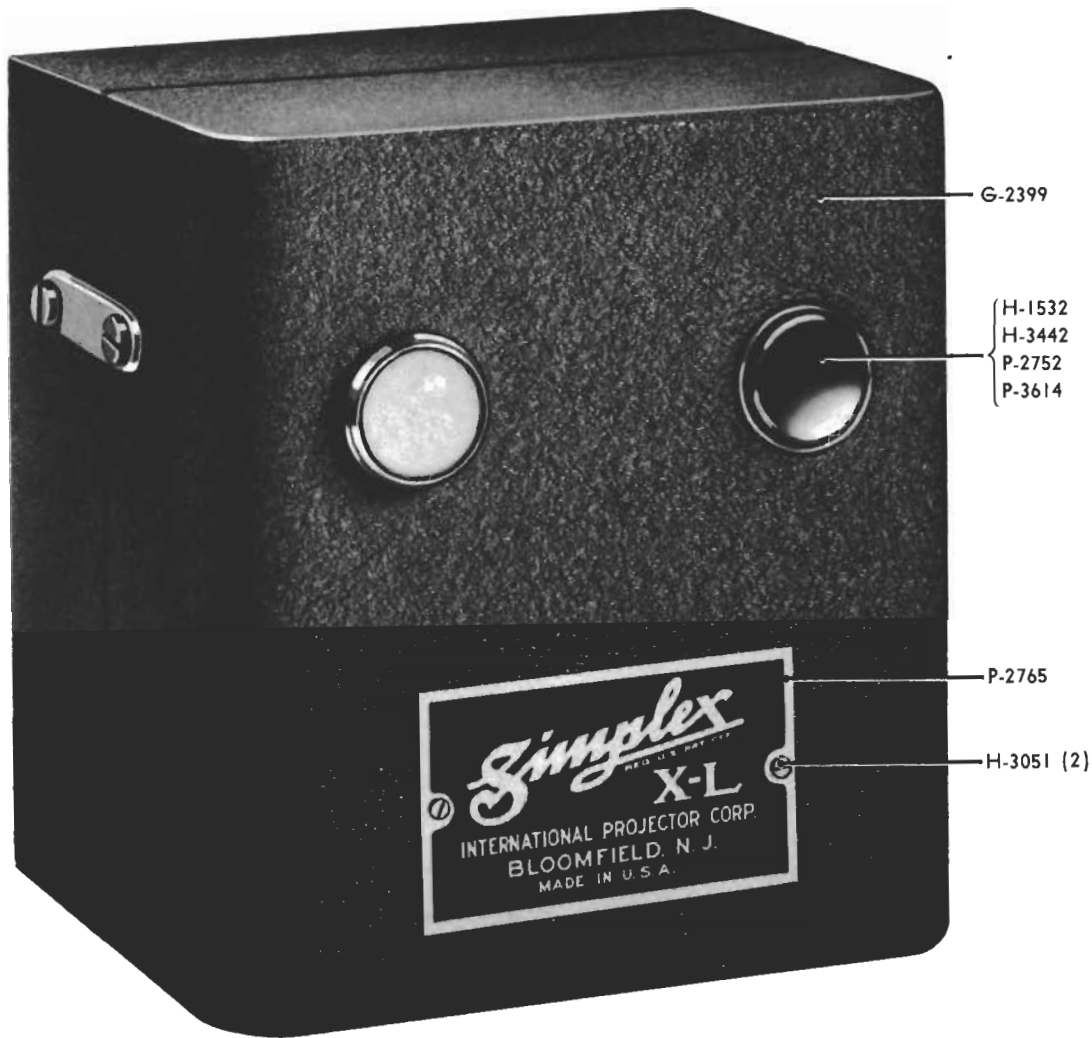

## AM-211 FOUR CHANNEL CHANGEOVER CABINET

G-2399	Cabinet (Includes H-3202 (4), P-1145 (4), P-1257 (2), P-1764 (4), P-2987 (2))	P-1257	Cabinet Link Screw Washer (2) (Included with G-2399)
G-2422	Terminal Strip	P-1278	Terminal Strip-Cable Clamp Lockwasher (5)
G-2425	Cable Form	P-1764	Cabinet Link Screw (4) (Included with G-2399)
H-1532	Changeover Switch Knob Set Screw	P-1859	Changeover Switch Fastening Nut
H-2716	Terminal Strip-Cable Clamp Fastening Screw (5)	P-2264	Pilot Light Socket
H-3051	Nameplate Fastening Screw (2)	P-2752	Changeover Switch Knob Spring
H-3202	Cabinet Link Screw Fastening Nut (4) (Included with G-2399)	P-2765	Nameplate
H-3226	Cable Clamp Fastening Nut	P-2987	Cabinet Link (2) (Included with G-2399)
H-3442	Changeover Switch Lockwasher	P-3061	Cable Clamp
P-1145	Cabinet Link Screw Lockwasher (4) (Included with G-2399)	P-3570	Changeover Switch
		P-3588	Capacitor, .25 mf, 200 V
		P-3611	Pilot Light, 28 V
		P-3614	Changeover Switch Knob



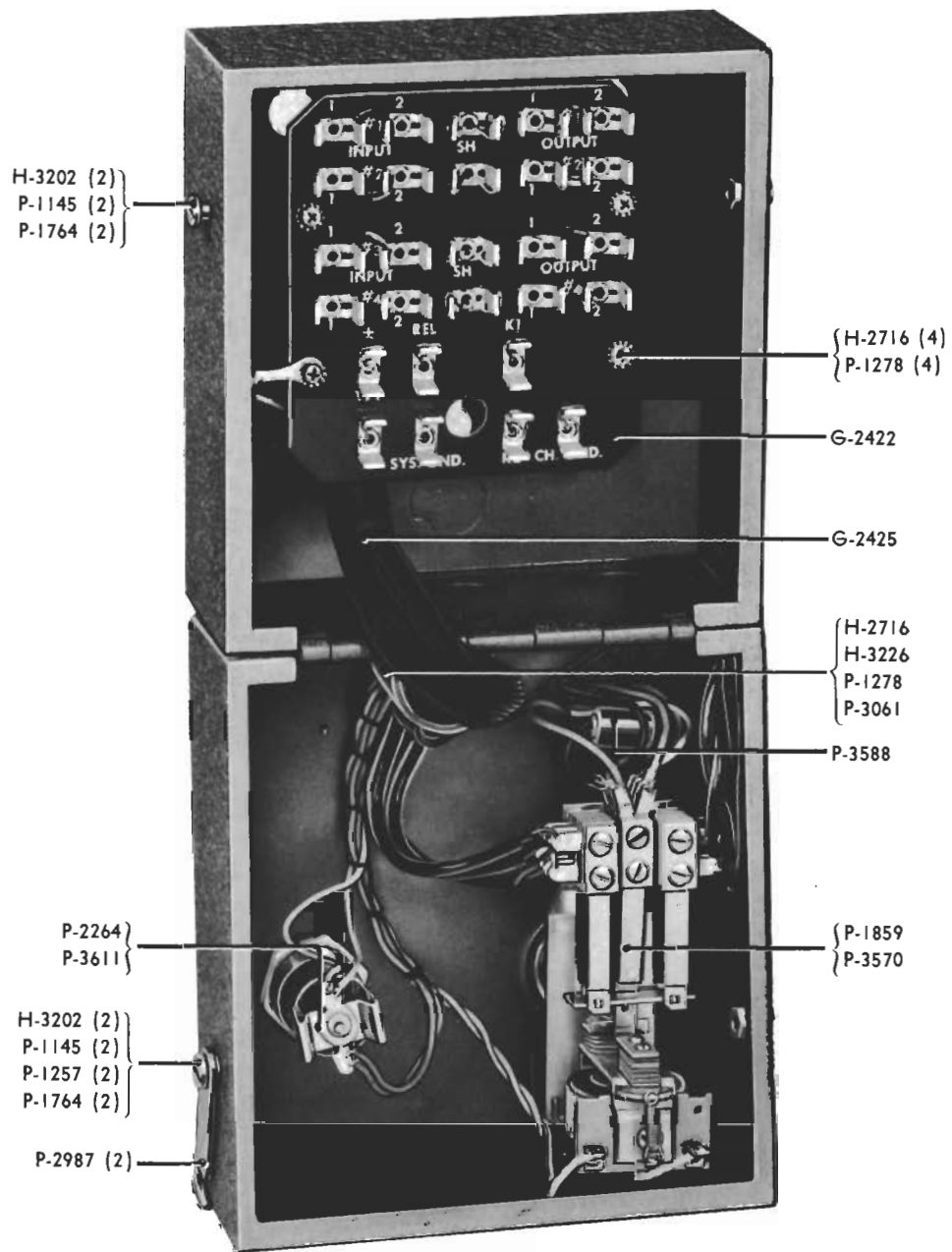

AM-211 FOUR CHANNEL CHANGEOVER CABINET

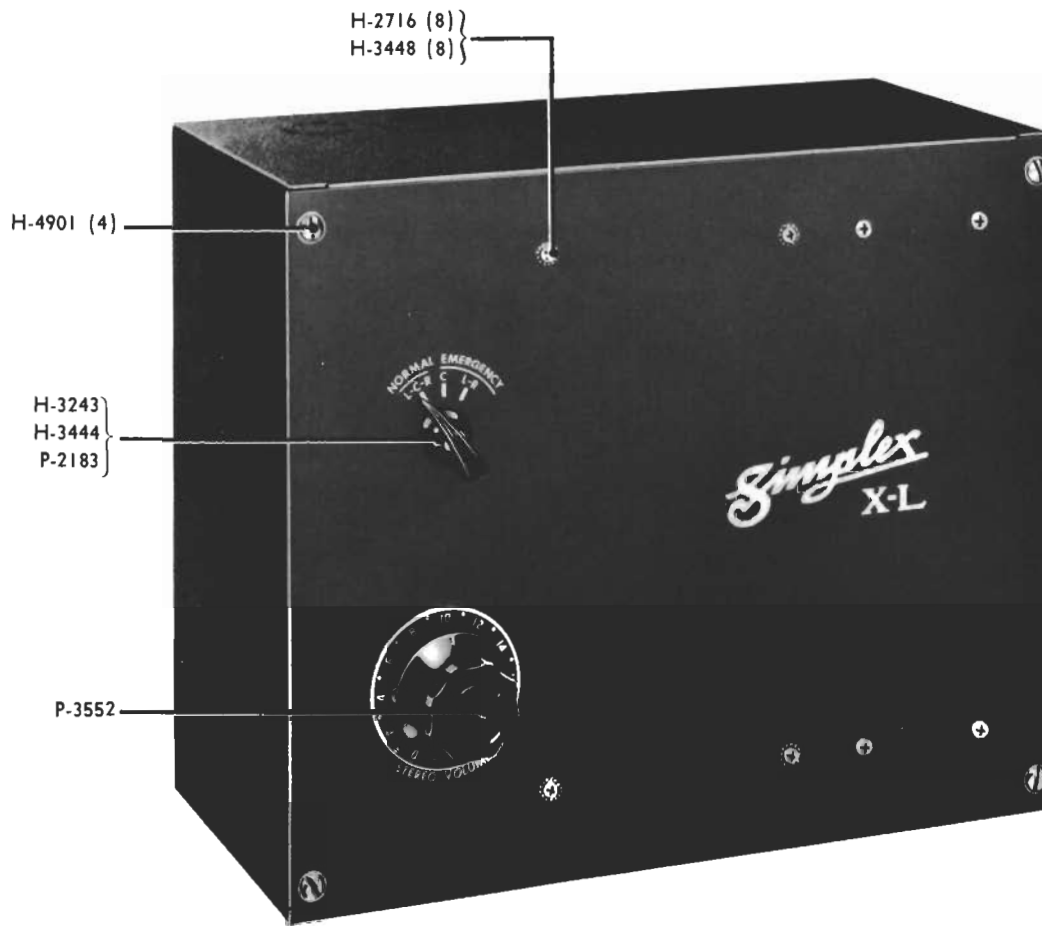

### AM-212 BALANCE-WARPING CABINET

G-2426	Terminal Strip	H-4901	Panel Fastening Screw (4)
G-2432	Resistor Mounting Strip and Lugs	*P-1004	Resistor, 750 Ohms, 1 Watt (6)
G-2439	Cable Form, Resistor Mounting Strip	P-2040	Resistor, 510 Ohms, 1 Watt (15)
G-2440	Cable Form	*P-2125	Resistor, 1500 Ohms, 1 Watt (6)
H-2716	Terminal-Resistor Mounting Strip	P-2183	Switch Knob
H-2718	Fastening Screw (16)	P-2802	Resistor, 300 Ohms, 1 Watt (6)
H-2747	Terminal Strip Support-Cable	P-2999	Cable Clamp
H-3226	Clamp Fastening Screw (2)	P-3339	Resistor Mounting Strip Stud (4)
H-3240	Relay Fastening Screw (4)	P-3552	Volume Control, Dial Plate, Knob and Screws
H-3243	Mounting Strip (Third Projector)	*P-3561	Resistor, 160 Ohms, 1 Watt (6)
H-3405	Mounting Screw Retaining Nut (4)	P-3562	Resistor, 820 Ohms, 1 Watt (6)
H-3444	Terminal Strip Support-Cable	*P-3563	Resistor, 330 Ohms, 1 Watt (10)
H-3448	Clamp Lockwasher (2)	P-3584	Relay, 6 P.D.T.
	Terminal-Mounting Strip	P-3586	Capacitor, 0.1 mf, 200 V (12)
	Lockwasher (16)	*P-3587	Capacitor, 0.15 mf, 200 V (12)
		P-3590	Relay, 3 P.D.T.
		P-3597	Terminal Strip Support (2)
		P-3599	Panel
		P-3600	Cabinet
		P-3603	Selector Switch
		P-3605	Resistor, 240 Oms, 1 Watt (4)
		P-3606	Resistor, 680 Oms, 1 Watt (2)

\* Shipped separately with AM-212 as alternate parts for attenuating and warping networks. Only (6) P-3563 are included with this separate shipment.

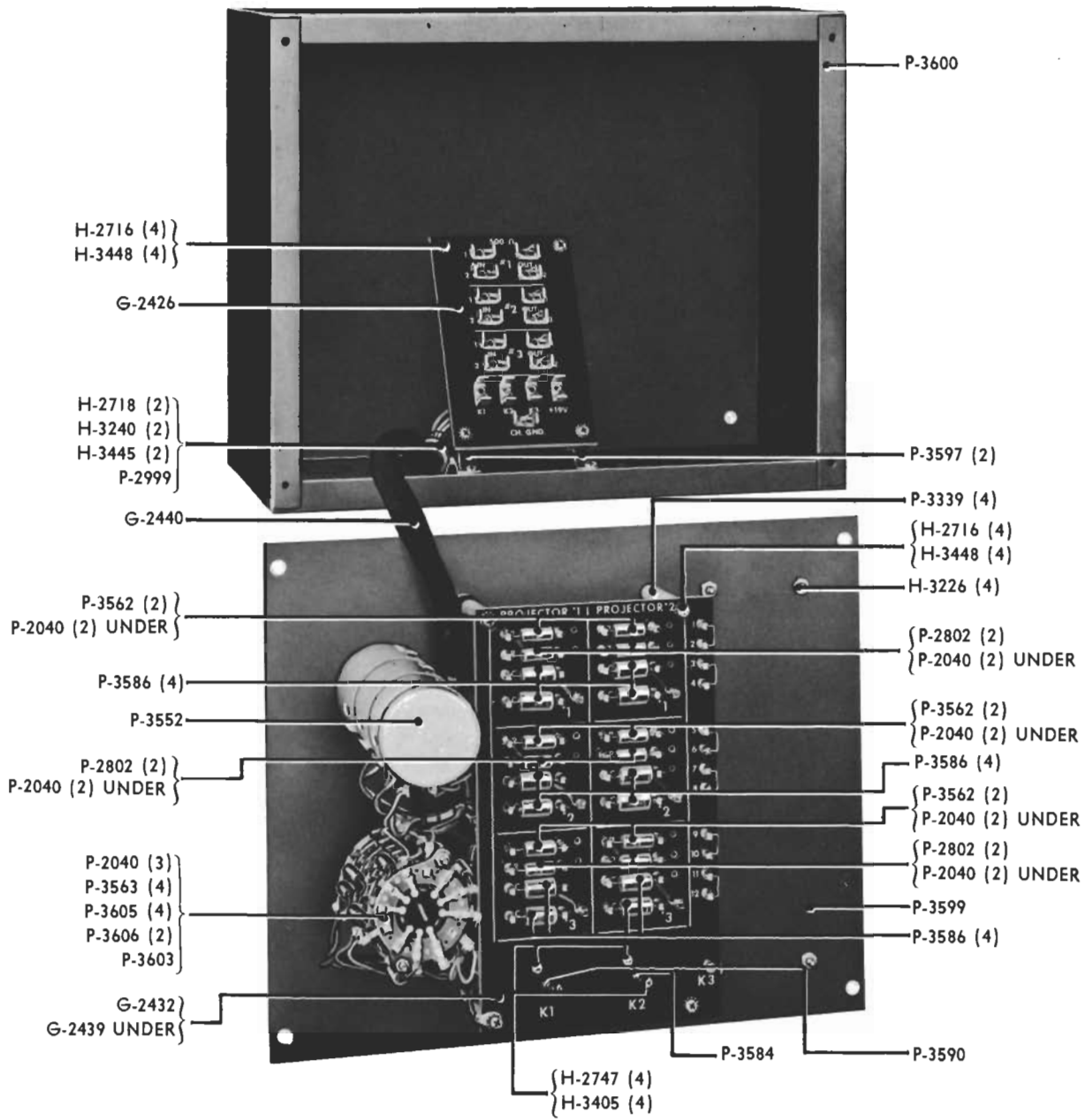

AM-212 BALANCE-WARPING CABINET

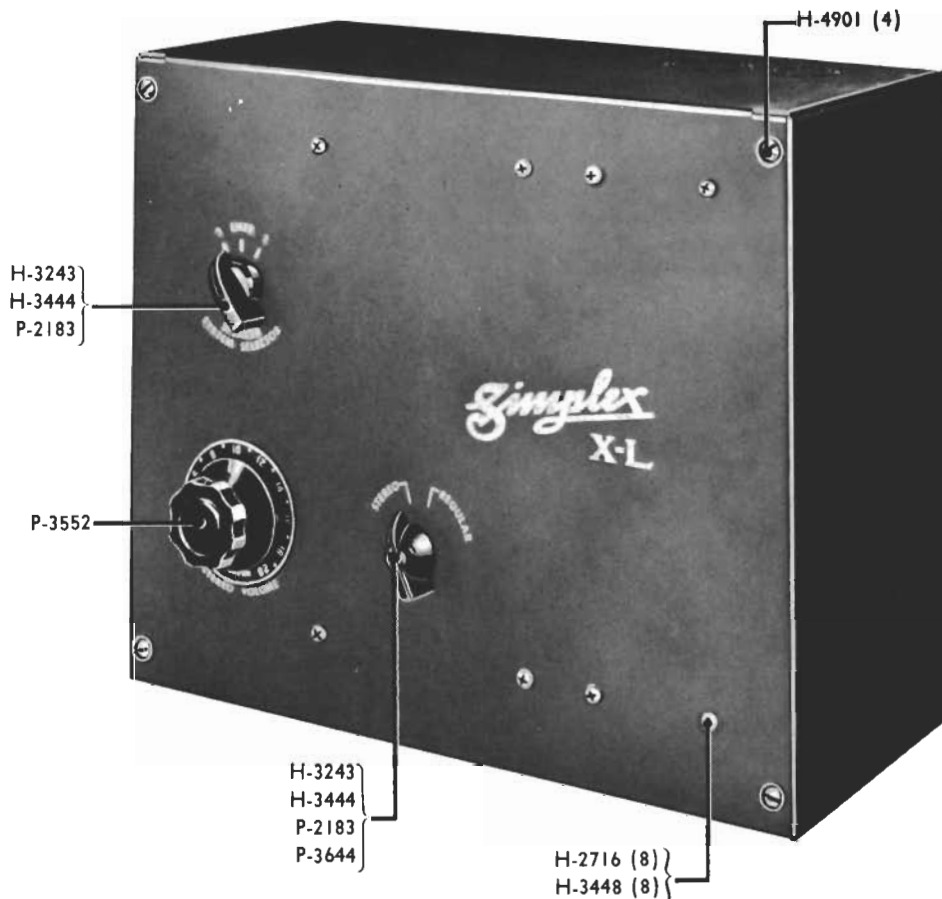

### AM-213 SYSTEM SELECTOR AND CONTROL CABINET

G-2426	Terminal Strip	P-2048	Resistor, 1 Meg., 1 Watt
G-2432	Mounting Strip and Lugs, Warping Networks	P-2069	Resistor, 15 K, 1 Watt (2)
G-2439	Cable Form	P-2099	Capacitor, .1 mf, 400 V
G-2455	Mounting Strip and Lugs, Transformer	*P-2125	Resistor, 1500 Ohms, 1 Watt (6)
G-2457	Cable Form	P-2183	System Selector-Stereo & Regular Switch Knob (2)
G-2458	Cable Form	P-2802	Resistor, 300 Ohms, 1 Watt (6)
H-2716	Terminal-Resistor Mounting Strip- Stud-Fastening Screw (20)	P-2999	Cable Clamp
H-2718	Terminal Strip Support-Cable Clamp Fastening Screw (2)	P-3339	Warping Networks Mounting Strip Stud (4)
H-2747	Relay Fastening Screw (4)	P-3428	Output Transformer (2)
H-3226	Transformer Fastening Nut (8)	P-3452	Transformer Mounting Strip Stud (4)
H-3240	Terminal Strip Support-Cable Clamp Fastening Nut (2)	P-3552	Volume Control, Dial Plate, Knob and Screws
H-3243	System Selector-Stereo & Regular Switch Fastening Nut (2)	*P-3561	Resistor, 160 Ohms, 1 Watt (6)
H-3405	Relay Lockwasher (4)	P-3562	Resistor, 820 Ohms, 1 Watt (6)
H-3444	System Selector-Stereo & Regular Switch Lockwasher (2)	*P-3563	Resistor, 300 Ohms, 1 Watt (11)
H-3445	Terminal Strip Support-Cable Clamp Lockwasher (2)	P-3584	Relay, 6 P.D.T.
H-3448	Terminal-Resistor Mounting Strip- Stud-Transformer Lockwasher (28)	P-3586	Capacitor, .1 mf, 200 V (12)
H-4901	Panel Fastening Screw (4)	*P-3587	Capacitor, .15 mf, 200 V (12)
*P-1004	Resistor, 750 Ohms, 1 Watt (6)	P-3590	Relay, 3 P.D.T.
P-2040	Resistor, 510 Ohms, 1 Watt (17)	P-3597	Terminal Strip Support (2)
		P-3600	Cabinet
		P-3603	System Selector Switch
		P-3605	Resistor, 240 Ohms, 1 Watt (4)
		P-3606	Resistor, 680 Ohms, 1 Watt
		P-3641	Panel
		P-3644	Stereo and Regular Selector Switch

\* Shipped separately with AM-213 as alternate parts for attenuating and warping networks. Only (6) P-3563 are included with this separate shipment.

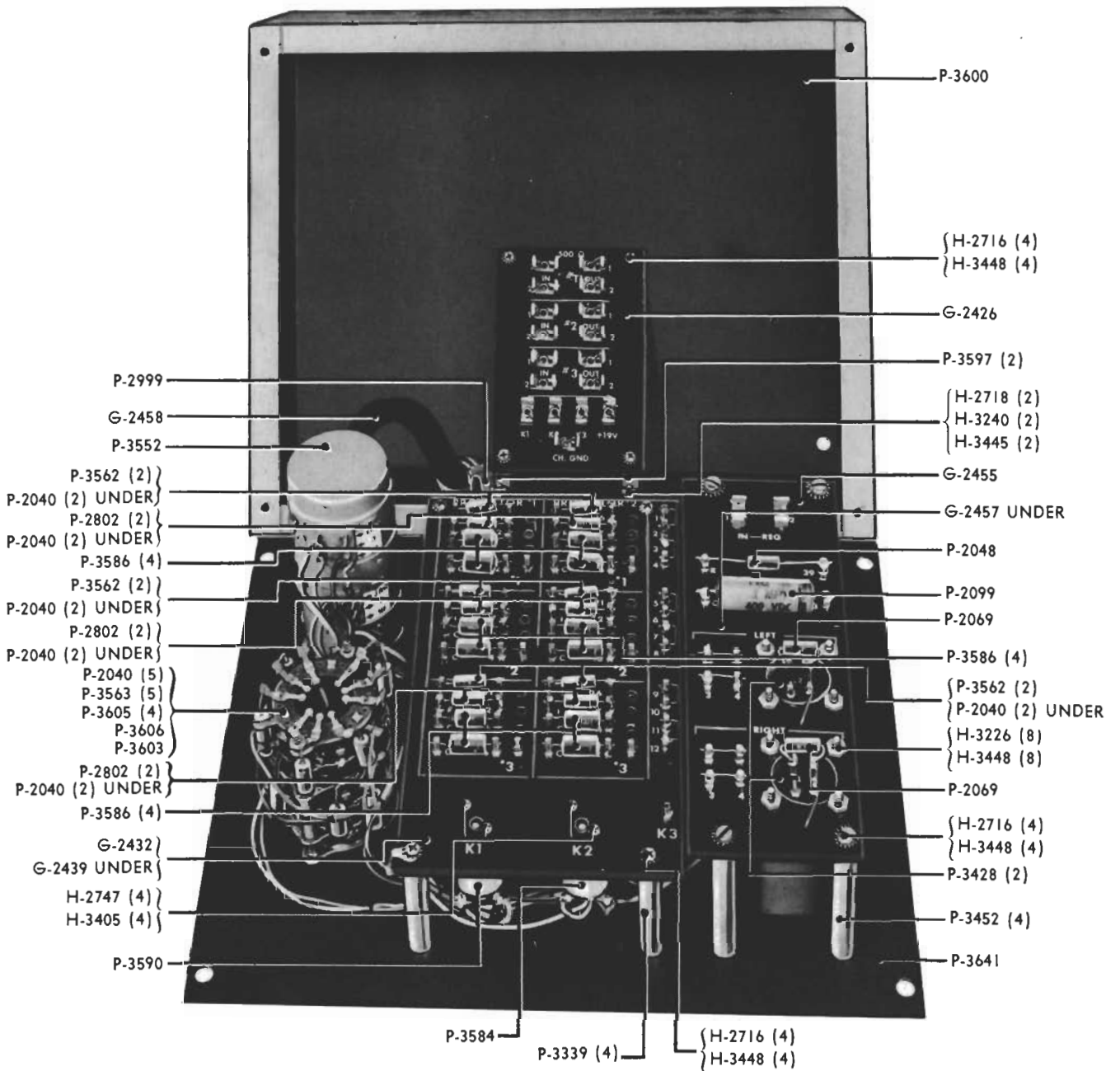

AM-213 SYSTEM SELECTOR AND CONTROL CABINET



## SECTION II

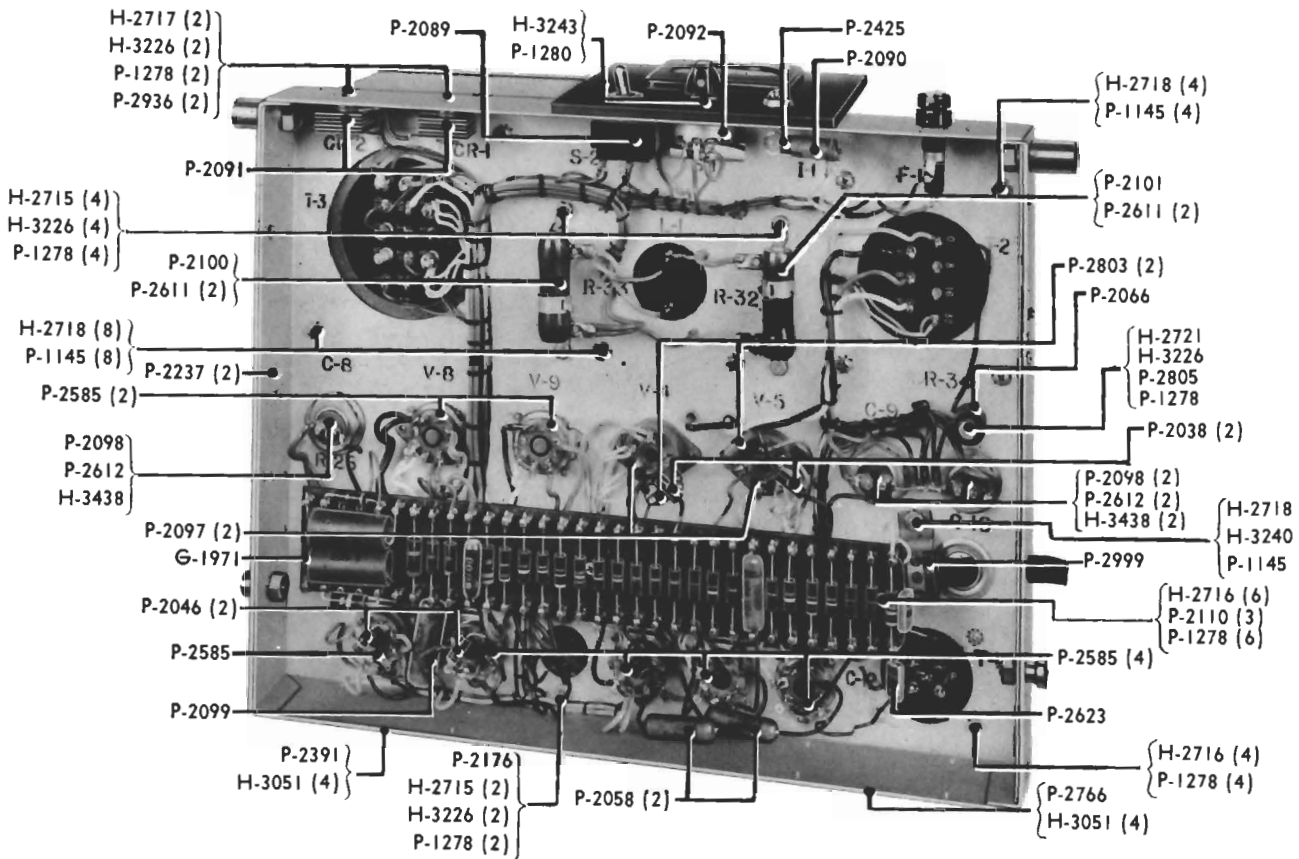
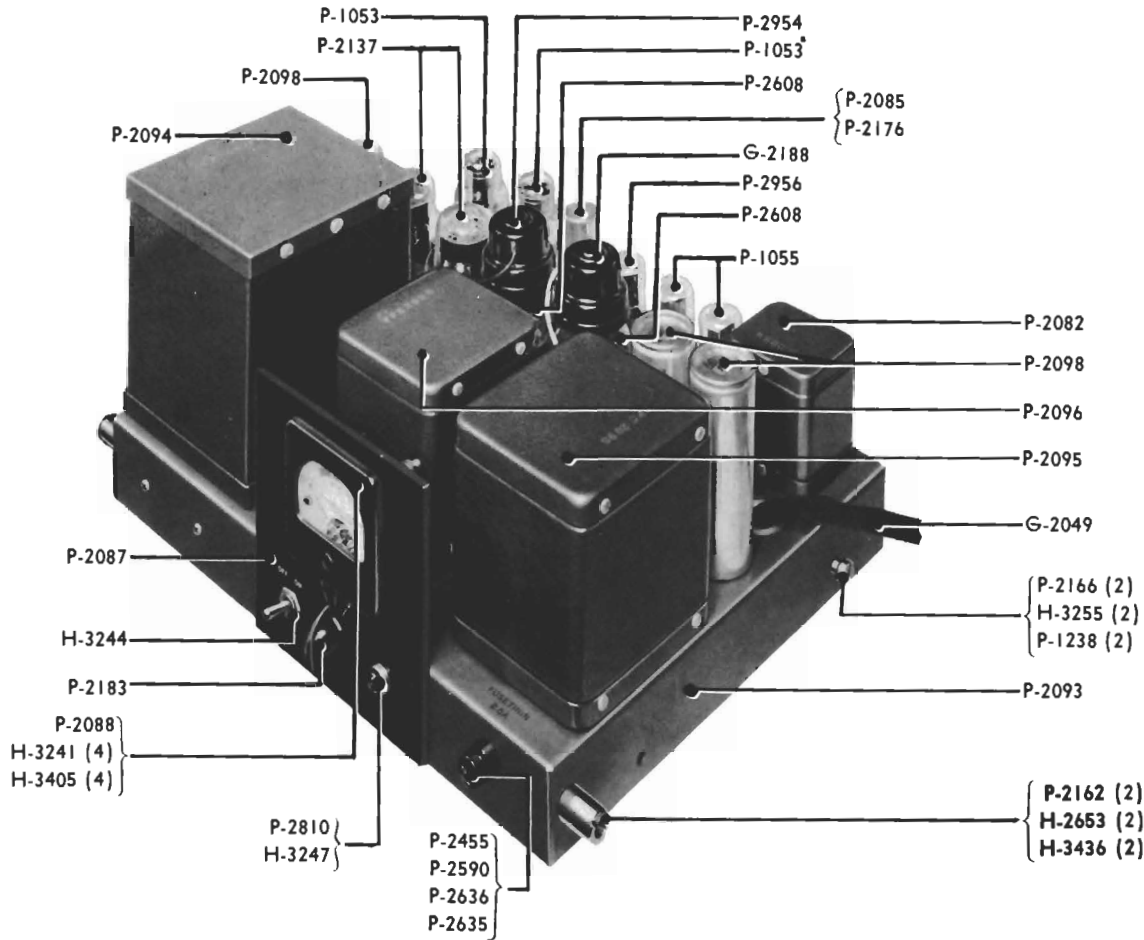

AM-1026 POWER AMPLIFIER

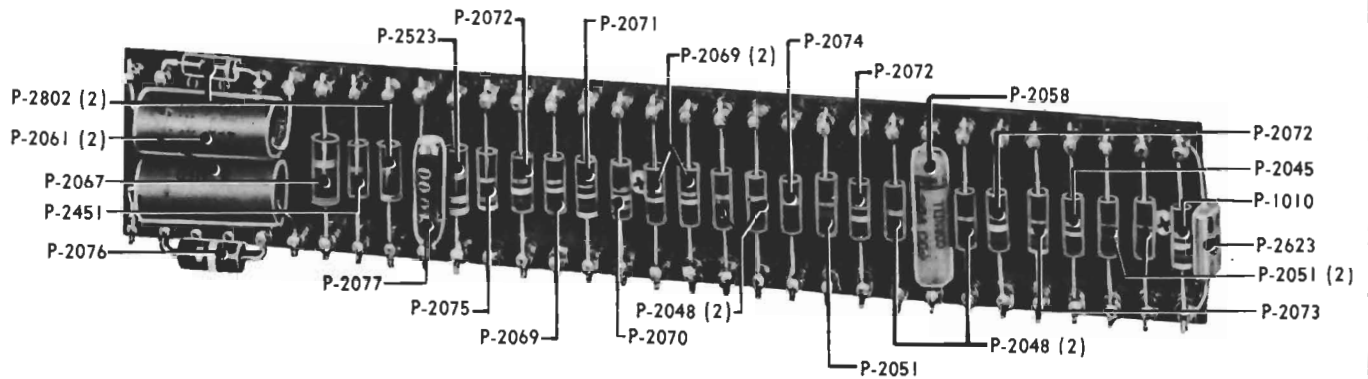

## AM-1026 POWER AMPLIFIER

G-1971	Resistor Mounting Strip and Lugs	P-2072	Resistor, 0.22 Meg., 1 watt (3)
G-2049	Cable Form	P-2073	Resistor, 0.36 Meg., 1 watt
G-2188	Vacuum Tube Cap and Wire	P-2074	Resistor, 2 Meg., 1 watt
H-2653	Chassis Stop Stud Fastening Screw (2)	P-2075	Resistor, 470 ohms, 1 watt
H-2715	Capacitor-Resistor Mounting Fastening Screw (6)	P-2076	Resistor, 0.1 Meg., 2 watt
H-2716	Resistor Mounting-Transformer Fastening Screw (10)	P-2077	Resistor, 8,000 ohms, 5 watt
H-2717	Rectifier Fastening Screw (2)	P-2082	Input Transformer
H-2718	Transformer-Reactor Fastening Screw (13)	P-2085	Capacitor, 20/25, 20/450, 20/450 Electrolytic
H-2721	Resistor Mounting Screw	P-2087	Front Panel
H-3051	Nameplate-License Plate Fastening Screw (8)	P-2088	Vacuum Tube Testing Meter
H-3226	Capacitor-Resistor Mounting-Rectifier Fastening Nut (9)	P-2089	AC Power Switch, D.P.S.T. Toggle
H-3240	Cable Clamp Fastening Nut	P-2090	Pilot Light Socket
H-3241	Tube Testing Meter Fastening Nut (4)	P-2091	Selenium Rectifier (2)
H-3243	Tube Testing Switch Fastening Nut	P-2092	Vacuum Tube Testing Switch
H-3244	AC Power Switch Fastening Nut (2)	P-2093	Chassis
H-3247	Pilot Light Socket Fastening Nut	P-2094	Power Transformer
H-3255	Chassis Stop Screw Fastening Nut (2)	P-2095	Output Transformer
H-3405	Tube Testing Meter Lockwasher (4)	P-2096	Reactor
H-3436	Chassis Stop Stud Lockwasher (2)	P-2097	Vacuum Tube Socket, 5 Prong (2)
H-3438	Capacitor Lockwasher (3)	P-2098	Capacitor, 4 mf, 600V (3)
P-1010	Resistor, 36,000 ohms, 1 watt	P-2099	Capacitor, 0.1 mf, 400V
P-1053	Vacuum Tube, OD3/VR-150 (2)	P-2100	Resistor, 3,500 ohms, 25 watt
P-1055	Vacuum Tube, 6SL7-GT (2)	P-2101	Resistor, 1,500 ohms, 25 watt
P-1145	Transformer-Reactor Lockwasher (13)	P-2110	Resistor Strip Mounting Stud (3)
P-1238	Chassis Stop Screw Lockwasher (2)	P-2137	Vacuum Tube, 5 R4-GY (2)
P-1278	Capacitor-Resistor Mounting-Transformer Lockwasher (19)	P-2162	Chassis Stop Stud (2)
P-1280	Tube Testing Switch Lockwasher	P-2166	Chassis Stop Screw (2)
P-2038	Resistor, 5 ohms, 1 watt (2)	P-2176	Capacitor Mounting Plate
P-2045	Resistor, 0.1 Meg., 1 watt	P-2183	Tube Testing Switch Knob
P-2046	Resistor, 0.47 Meg., 1 watt (2)	P-2237	Chassis Reinforcement Plate (2)
P-2048	Resistor, 1 Meg., 1 watt (4)	P-2391	License Plate
P-2051	Resistor, 1,000 ohms, 1 watt (3)	P-2425	Pilot Light, 6-8V
P-2058	Capacitor, 0.01 mf, 600V (3)	P-2451	Resistor, 22 ohms, 1 watt
P-2061	Capacitor, 8 mf, 250V Electrolytic (2)	P-2455	Fuse, 2.5 Amp. Cartridge Fusetron
P-2066	Resistor, 0.2 ohms, 2 watt	P-2523	Resistor, 3,300 ohms, 2 watt
P-2067	Resistor, 7,500 ohms, 2 watt	P-2585	Vacuum Tube Socket, Octal (7)
P-2069	Resistor, 15,000 ohms, 1 watt (3)	P-2590	Fuse Holder
P-2070	Resistor, 68,000 ohms, 1 watt	P-2608	Vacuum Tube, #807 (2)
P-2071	Resistor, 91,000 ohms, 1 watt	P-2611	Resistor Mounting Bracket (4)
		P-2612	Capacitor Lock Nut (3)
		P-2623	Capacitor, 50 mmf, 500V (2)
		P-2635	Fuse Holder Rubber Washer
		P-2636	Fuse Holder Fastening Nut
		P-2766	Nameplate
		P-2802	Resistor, 300 ohms, 1 watt (2)
		P-2803	Capacitor, 200 mmf, 500V (2)
		P-2805	Resistor Insulating Bushing
		P-2810	Pilot Light Lens
		P-2936	Rectifier Insulating Washer (2)
		P-2954	Vacuum Tube Cap
		P-2956	Vacuum Tube, 6SN7-GTA
		P-2999	Cable Clamp

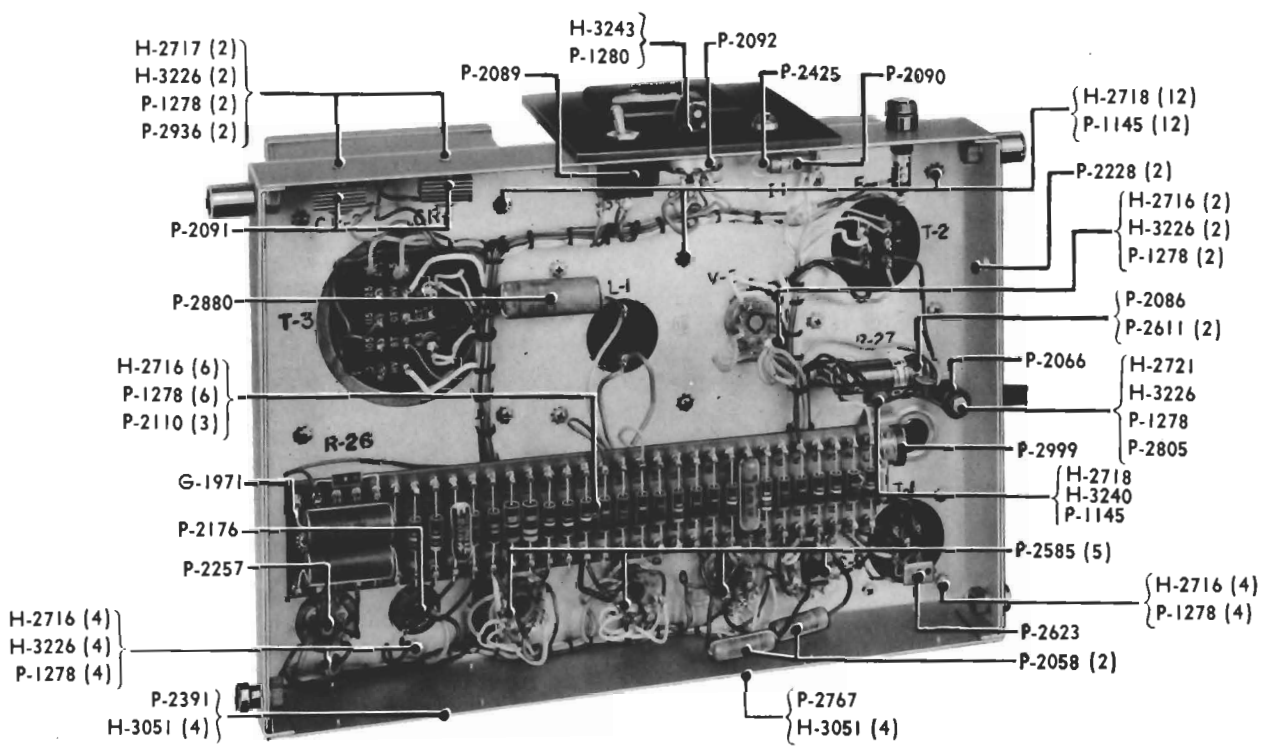
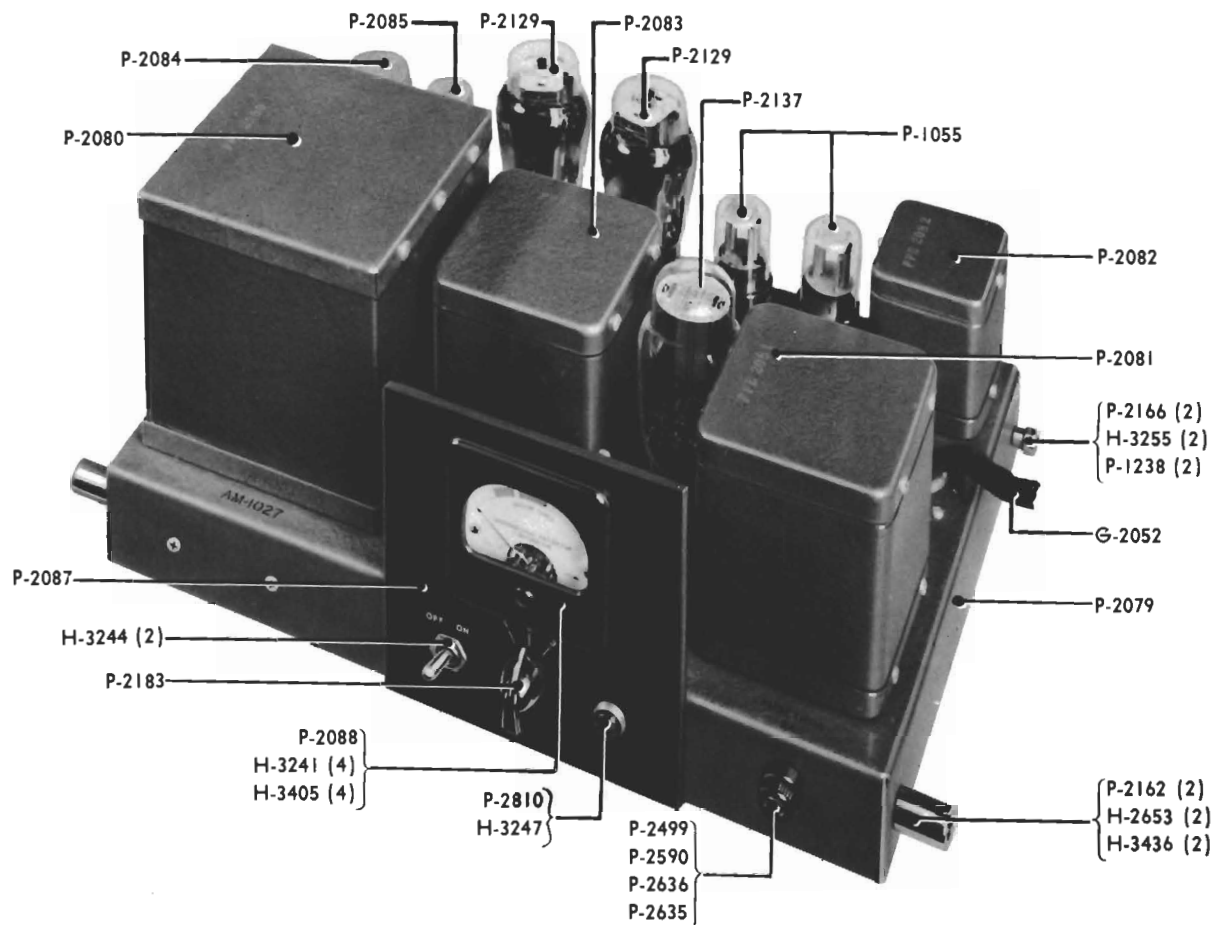

AM-1027 POWER AMPLIFIER

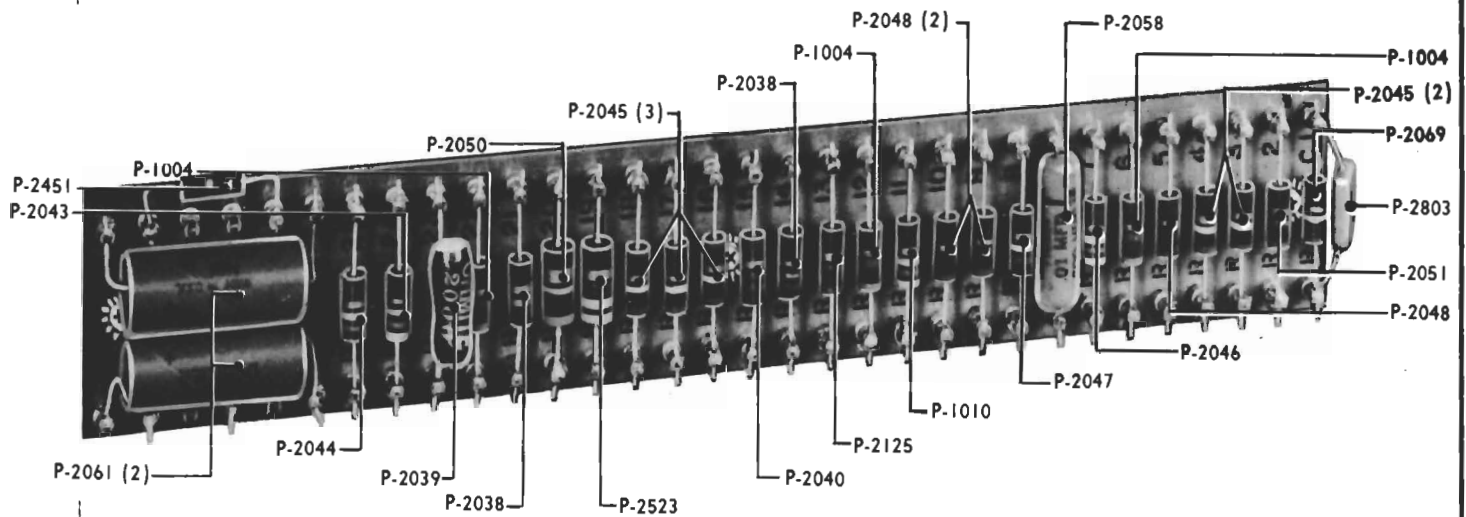

### AM-1027 POWER AMPLIFIER

G-1971	Resistor Mounting Strip and Lugs	P-2061	Capacitor, 8 mf, 250V Electrolytic (2)
G-2052	Cable Form	P-2066	Resistor, 0.2 ohms, 2 watt
H-2653	Chassis Stop Stud Fastening Screw (2)	P-2069	Resistor, 15,000 ohms, 1 watt
H-2716	Capacitor Plate-Resistor Bracket Fastening Screw (16)	P-2079	Chassis
H-2717	Rectifier Mounting Screw (2)	P-2080	Power Transformer
H-2718	Transformer Fastening Screw (13)	P-2081	Output Transformer
H-2721	Resistor Mounting Screw	P-2082	Input Transformer
H-3051	Nameplate-License Plate Fastening Screw (8)	P-2083	Reactor
H-3226	Capacitor Plate-Resistor Bracket Fastening Nut (9)	P-2084	Capacitor, 40/450, 40/450 Electrolytic
H-3240	Cable Clamp Fastening Nut	P-2085	Capacitor, 20/25, 20/450, 20/450 Electrolytic
H-3241	Tube Testing Meter Fastening Nut (4)	P-2086	Resistor, 10,000 ohms, 25 watt
H-3243	Tube Testing Switch Fastening Nut	P-2087	Front Panel
H-3244	AC Power Switch Fastening Nut (2)	P-2088	Tube Testing Meter
H-3247	Pilot Light Lens Fastening Nut	P-2089	AC Power Switch, D.P.S.T. Toggle
H-3255	Chassis Stop Screw Fastening Nut (2)	P-2090	Pilot Light Socket
H-3405	Tube Testing Meter Lockwasher (4)	P-2091	Selenium Rectifier (2)
H-3436	Chassis Stop Stud Lockwasher (2)	P-2092	Tube Testing Switch
P-1004	Resistor, 750 ohms, 1 watt (3)	P-2110	Resistor Strip Mounting Stud (3)
P-1010	Resistor, 36,000 ohms, 1 watt	P-2125	Resistor, 1,500 ohms, 1 watt
P-1055	Vacuum Tube, 6 SL7GT (2)	P-2129	Vacuum Tube, 6L6-G (2)
P-1145	Transformer-Reactor Lockwasher (13)	P-2137	Vacuum Tube, 5R4GY
P-1238	Chassis Stop Screw Lockwasher (2)	P-2162	Chassis Stop Stud (2)
P-1278	Capacitor Plate-Resistor Bracket Lockwasher (19)	P-2166	Chassis Stop Screw (2)
P-1280	Tube Testing Switch Lockwasher	P-2176	Capacitor Mounting Plate
P-2038	Resistor, 5 ohms, 1 watt (2)	P-2183	Tube Testing Switch Knob
P-2039	Resistor, 2,000 ohms, 5 watt	P-2228	Chassis Reinforcement Plate (2)
P-2040	Resistor, 510 ohms, 1 watt	P-2257	Capacitor Mounting Plate
P-2043	Resistor, 47,000 ohms, 1 watt	P-2391	License Plate
P-2044	Resistor, 27,000 ohms, 1 watt	P-2425	Pilot Light, 6-8V
P-2045	Resistor, 0.1 Meg., 1 watt (5)	P-2451	Resistor, 22 ohms, 1 watt
P-2046	Resistor, 0.47 Meg., 1 watt	P-2499	Fuse, 2 Amp. Cartridge Fusetron
P-2047	Resistor, 0.51 Meg., 1 watt	P-2523	Resistor, 3,300 ohms, 2 watt
P-2048	Resistor, 1 Meg., 1 watt (3)	P-2585	Vacuum Tube Socket, Octal (5)
P-2050	Resistor, 75,000 ohms, 2 watt	P-2590	Fuse Holder
P-2051	Resistor, 1,000 ohms, 1 watt	P-2611	Resistor Mounting Bracket (2)
P-2058	Capacitor, .01 mf, 600V (3)	P-2623	Capacitor, 50 mmf, 500V
		P-2635	Fuse Holder Rubber Washer
		P-2636	Fuse Holder Fastening Nut
		P-2767	Nameplate
		P-2803	Capacitor, 200 mmf, 500V
		P-2805	Resistor Insulating Bushing
		P-2810	Pilot Light Lens
		P-2880	Capacitor, 0.1 mf, 600V
		P-2936	Rectifier Insulating Washer (2)
		P-2999	Cable Clamp

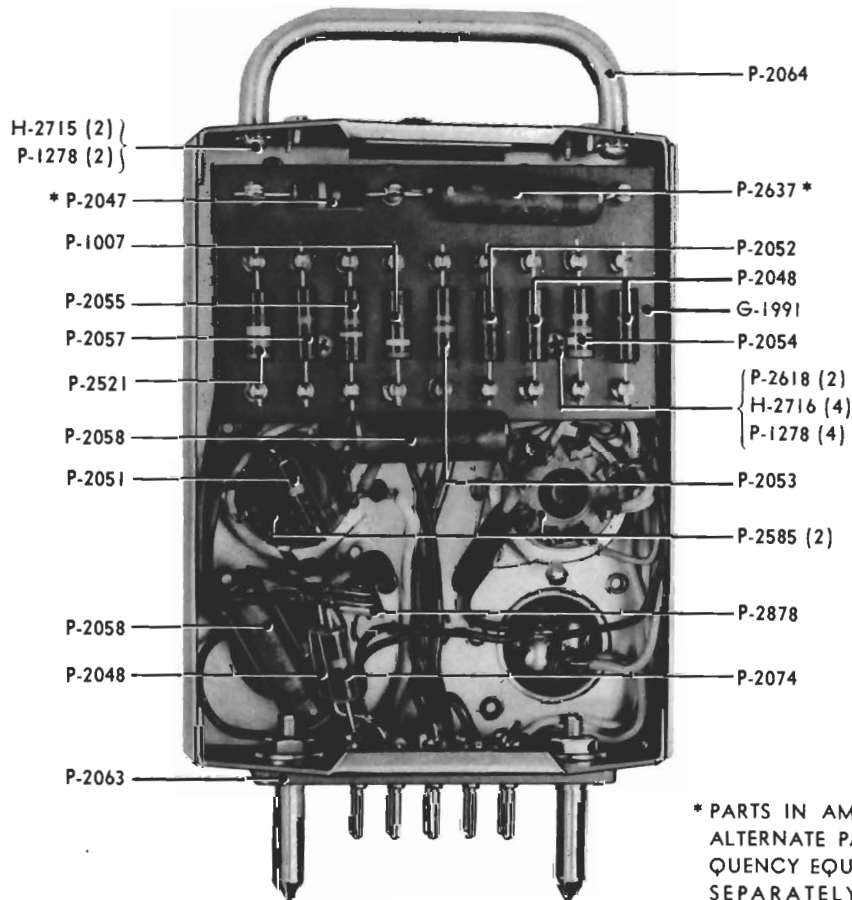
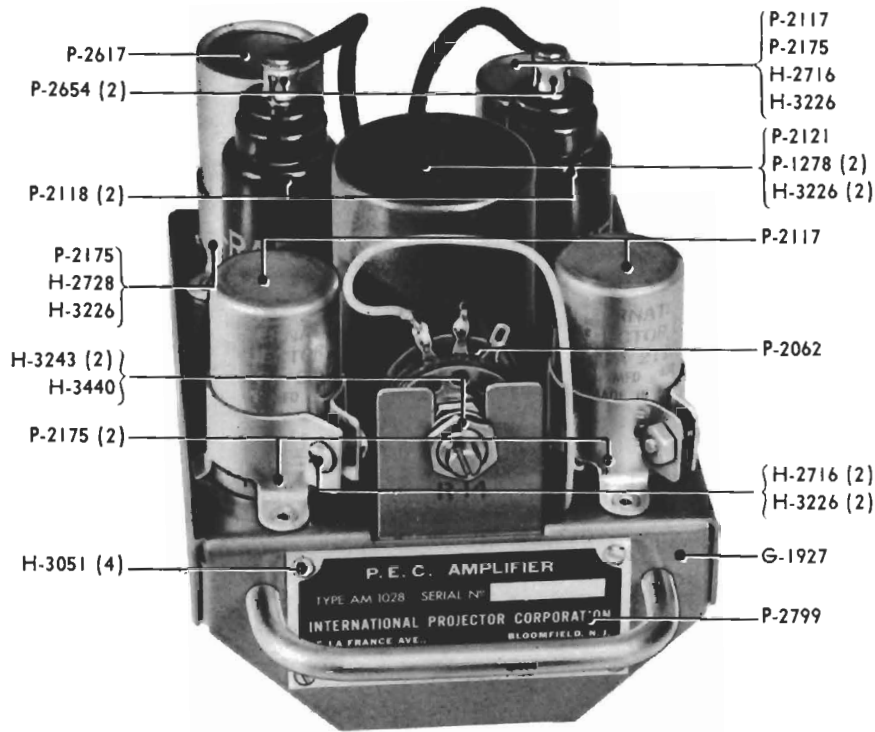

AM-1028 PEC AMPLIFIER

## AM-1028 PEC AMPLIFIER

G-1927	Chassis and Bracket
G-1991	Mounting Strip and Lugs
H-2715	Handle Fastening Screw (2)
H-2716	Capacitor Clamping-Resistor Strip Fastening Screw (7)
H-2728	Capacitor Clamping Screw
H-3051	Nameplate Fastening Screw (4)
H-3226	Capacitor Ring-Transformer Fastening Nut (6)
H-3243	Balance Control Fastening Nut (2)
H-3440	Balance Control Lockwasher
P-1007	Resistor, 3,900 ohms, 1 watt
P-1278	Transformer-Resistor Strip-Handle Lockwasher (8)
P-2047	Resistor, 0.51 Meg., 1 watt
P-2048	Resistor, 1 Meg., 1 watt (3)
P-2051	Resistor, 1,000 ohms, 1 watt
P-2052	Resistor, 2,000 ohms, 1 watt
P-2053	Resistor, 12,000 ohms, 1 watt
P-2054	Resistor, 39,000 ohms, 1 watt
P-2055	Resistor, 0.27 Meg., 1 watt
P-2057	Resistor, 1.5 Meg., 1 watt
P-2058	Capacitor, 0.01 mf, 600V (2)
P-2062	Balance Control
P-2063	Panel Connector, Male
P-2064	Handle
P-2074	Resistor, 2 Meg., 1 watt
P-2117	Capacitor, 0.05 mf, 400V (3)
P-2118	Vacuum Tube, 6J7 (2)
P-2121	Output Transformer
P-2175	Capacitor Mounting Ring (4)
P-2521	Resistor, 0.33 Meg., 1 watt
P-2585	Vacuum Tube Socket, Octal (2)
P-2617	Capacitor, 25 mf, 25V Electrolytic
P-2618	Resistor Strip Mounting Stud (2)
P-2637	Capacitor, 0.003 mf, 600V
P-2654	Vacuum Tube Cap (2)
P-2799	Nameplate
P-2878	Terminal Strip

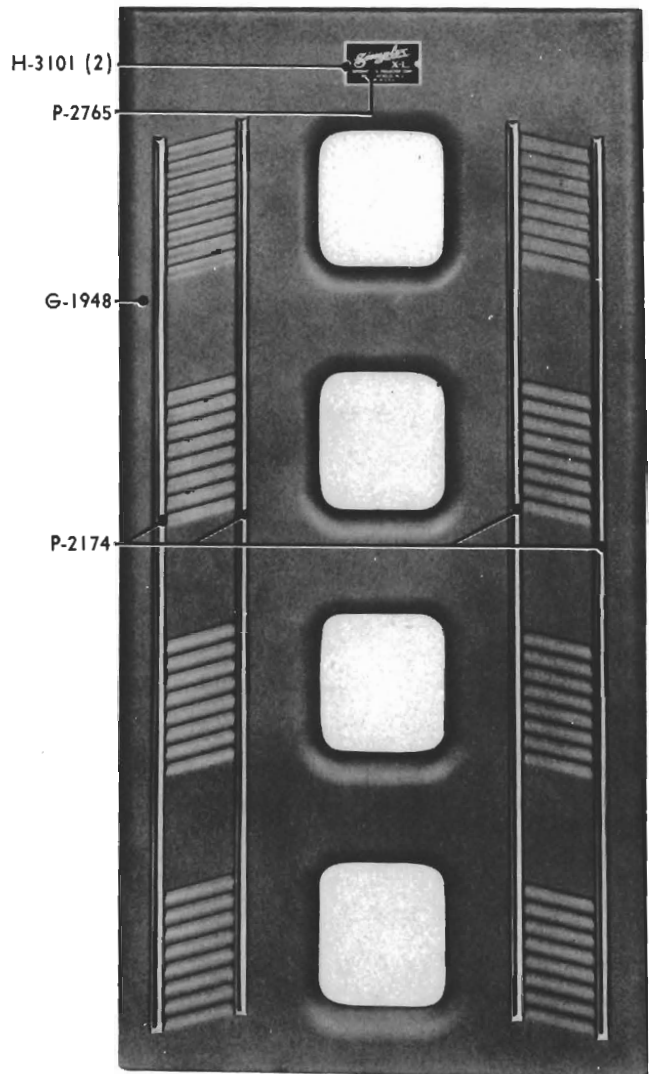
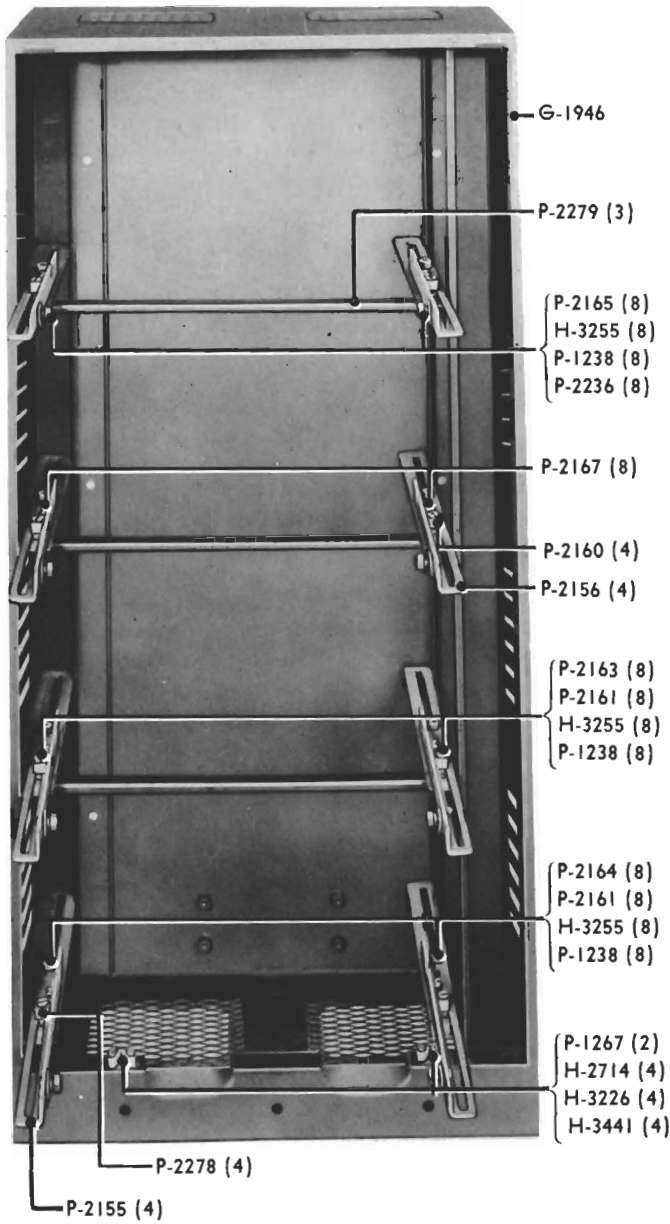

AM-1031 SYSTEM CABINET



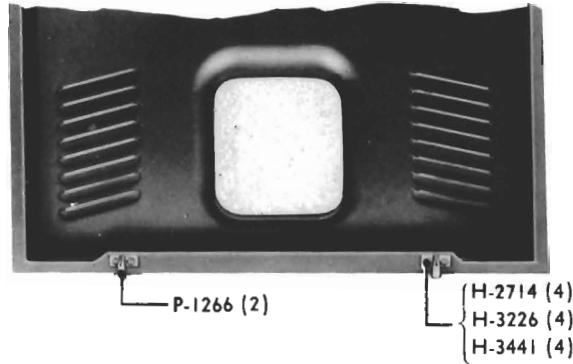

### AM-1031 SYSTEM CABINET

- G-1946 Cabinet
- G-1948 Cover, Molding and Door Strikes
  
- H-2714 Door Catch-Strike Fastening Screw (8)
- H-3101 Nameplate Fastening Screw (2)
- H-3226 Door Catch-Strike Fastening Nut (8)
- H-3255 Pivot-Slide Fastening Nut (24) \*
- H-3441 Door Catch-Strike Lockwasher (8)
  
- P-1238 Pivot-Slide Lockwasher (24) \*
- P-1266 Door Strike (2)
- P-1267 Door Catch (2)
- P-2155 Left Chassis Slide (4) \*
- P-2156 Right Chassis Slide (4) \*
- P-2160 Right Slide Top Lever (4) \*
- P-2161 Chassis Slide Spacer (16) \*
- P-2163 Front Slide Stop Screw (8) \*
- P-2164 Rear Slide Stop Screw (8) \*
- P-2165 Chassis Pivot Screw (8) \*
- P-2167 Stop Lever Fastening Screw (8) \*
- P-2174 Cover Molding (4)
- P-2236 Chassis Pivot Screw Spacing Washer (8) \*
- P-2278 Left Slide Stop Lever (4) \*
- P-2279 Cabinet Brace (3) \*
- P-2765 Nameplate

\* THE CABINET IS SHIPPED WITH THE TOP SECTION UNEQUIPPED AND THEREFORE INCLUDES ONLY 18 H-3255 AND P-1238; 3 P-2155, P-2156 AND P-2160 AND P-2278; 12 P-2161; 6 P-2163, P-2164, P-2165, P-2167 AND P-2236; AND 2 P-2279. THE PARTS TO EQUIP THE TOP SECTION ARE INCLUDED IN THE CABINET KITS.

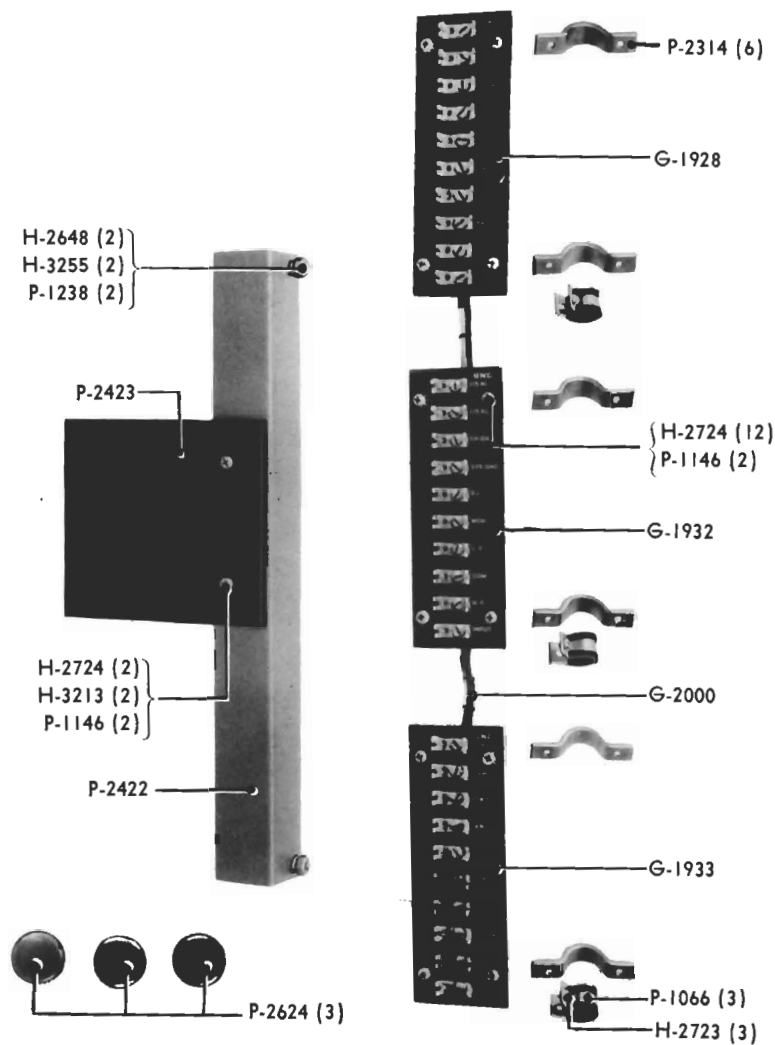

### AM-1032 CABINET KIT

G-1928	Power Amplifier Terminal Strip	H-3255	Mounting Bracket Fastening Nut (2)
G-1932	Network Terminal Strip	P-1066	Cable Clamp (3)
G-1933	Power Unit Terminal Strip	P-1146	Terminal Strip Lockwasher (14)
G-2000	Cable Form	P-1238	Mounting Bracket Lockwasher (2)
H-2648	Mounting Bracket Fastening Screw (2)	P-2314	Terminal Strip Clamp (6)
H-2723	Cable Clamp Fastening Screw (3)	P-2422	Blank Panel Mounting Bracket
H-2724	Terminal Strip-Blank Panel Fastening Screw (14)	P-2423	Blank Panel
H-3213	Blank Panel Fastening Nut (2)	P-2624	Apparatus Blank (3)

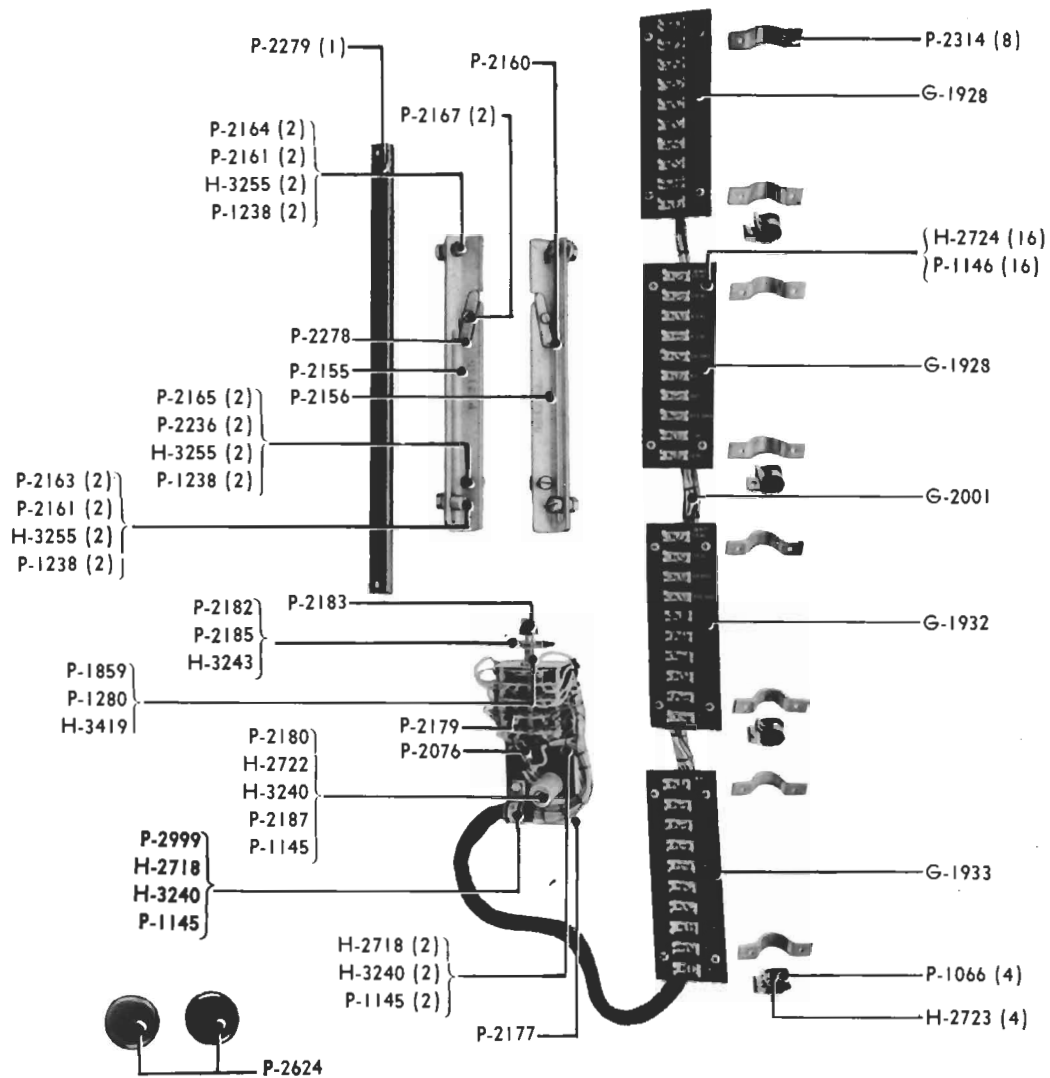

### AM-1033 CABINET KIT

- |        |   |        |  |
|--------|---|--------|--|
| G-1928 | Power Amplifier Terminal Strip (2)                    | P-1859 | Switch Fastening Nut                   |
| G-1932 | Network Terminal Strip                                | P-2076 | Resistor, 0.1 Meg., 2 watt             |
| G-1933 | Power Unit Terminal Strip                             | P-2155 | Left Chassis Slide                     |
| G-2001 | Cable Form  | P-2156 | Right Chassis Slide                    |
| H-2718 | Switch Bracket-Cable Clamp Fastening Screw (3)        | P-2160 | Right Slide Stop Lever                 |
| H-2722 | Resistor Mounting Screw                               | P-2161 | Slide Spacing Washer (4)               |
| H-2723 | Cable Clamp Fastening Screw (4)                       | P-2163 | Front Slide Stop Screw (2)             |
| H-2724 | Terminal Strip Fastening Screw (16)                   | P-2164 | Rear Slide Stop Screw (2)              |
| H-3240 | Switch Bracket-Cable Clamp-Resistor Fastening Nut (5) | P-2165 | Chassis Pivot Screw (2)                |
| H-3243 | Switch Dial Plate Fastening Nut                       | P-2167 | Stop Lever Fastening Screw (2)         |
| H-3255 | Slide-Pivot Screw Fastening Nut (6)                   | P-2177 | Switch Mounting Bracket                |
| H-3419 | Switch Lockwasher                                     | P-2179 | Selector Switch                        |
| P-1066 | Amplifier-Network-Power Unit Cable Clamp (4)          | P-2180 | Resistor, 60 ohms, 25 watt             |
| P-1145 | Switch Bracket-Cable Clamp-Resistor Lockwasher (4)    | P-2182 | Switch Dial Plate                      |
| P-1146 | Terminal Strip Lockwasher (16)                        | P-2183 | Switch Knob                            |
| P-1238 | Slide-Pivot Screw Lockwasher (6)                      | P-2185 | Switch Dial Plate Bushing              |
| P-1280 | Switch Lockwasher                                     | P-2187 | Resistor Washer                        |
|        |   | P-2236 | Chassis Pivot Screw Spacing Washer (2) |
|        |   | P-2278 | Left Slide Stop Lever                  |
|        |   | P-2279 | Cabinet Brace                          |
|        |   | P-2314 | Terminal Strip Clamp (8)               |
|        |   | P-2624 | Apparatus Blank (2)                    |
|        |   | P-2999 | Switch Cable Clamp                     |

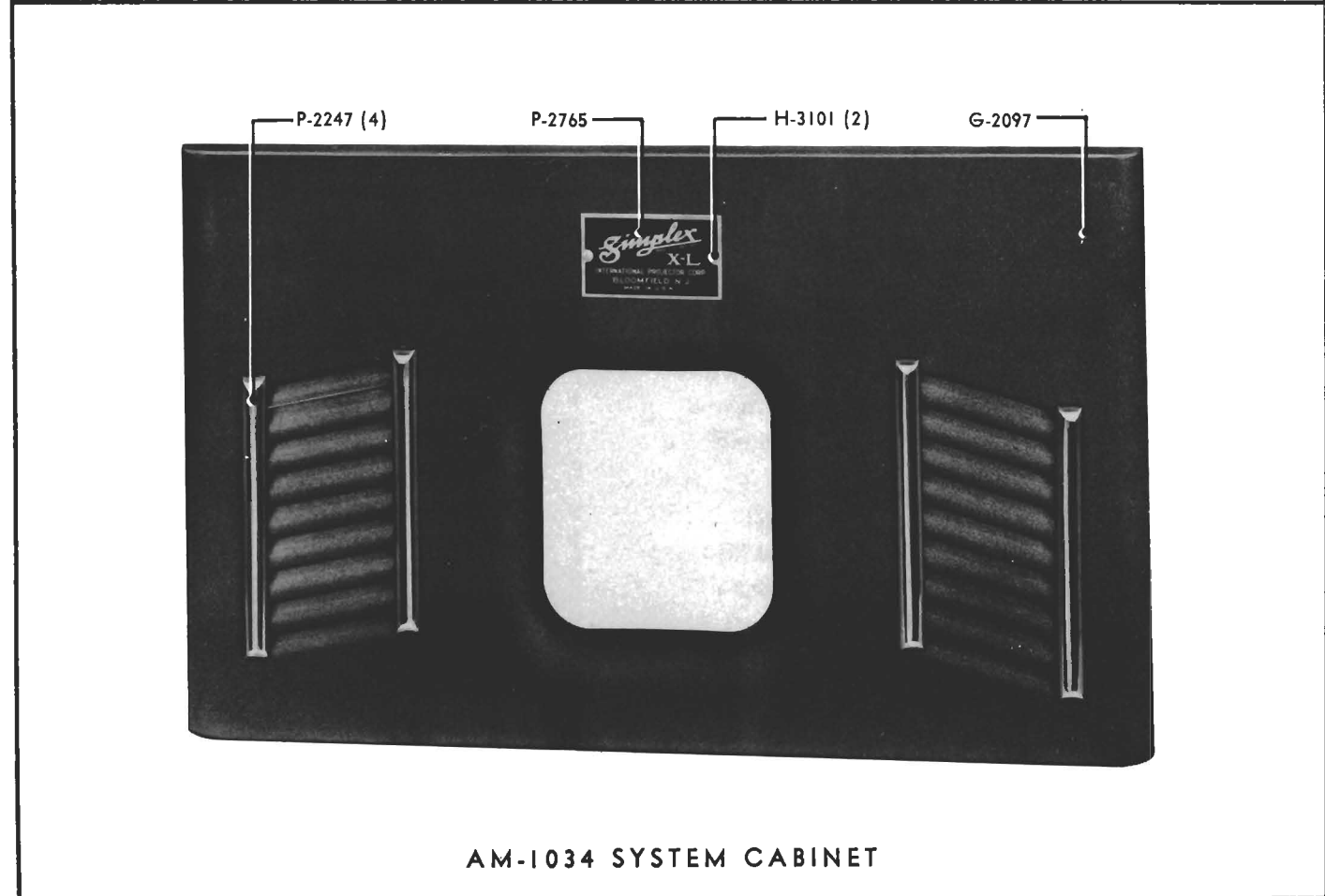
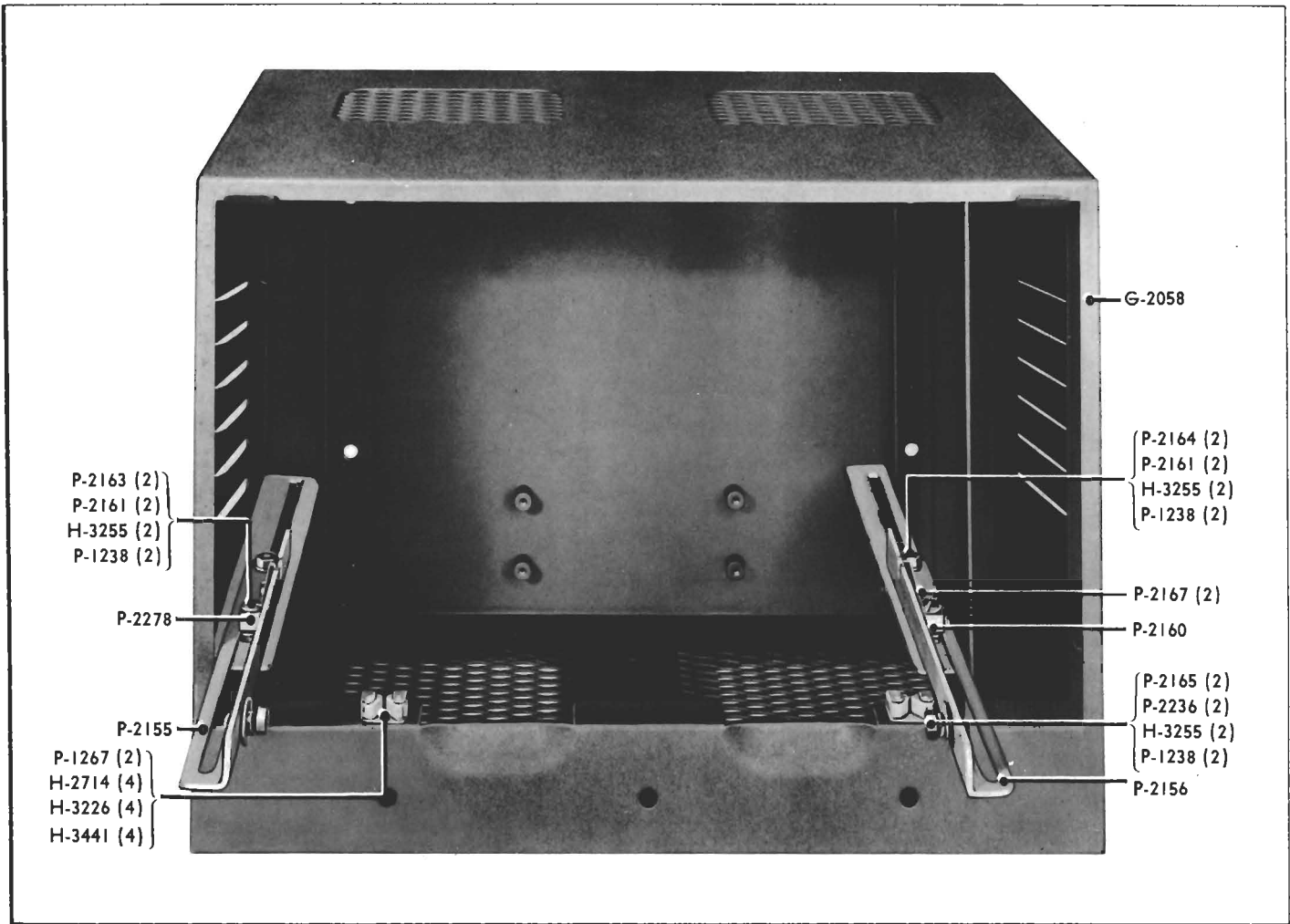

AM-1034 SYSTEM CABINET

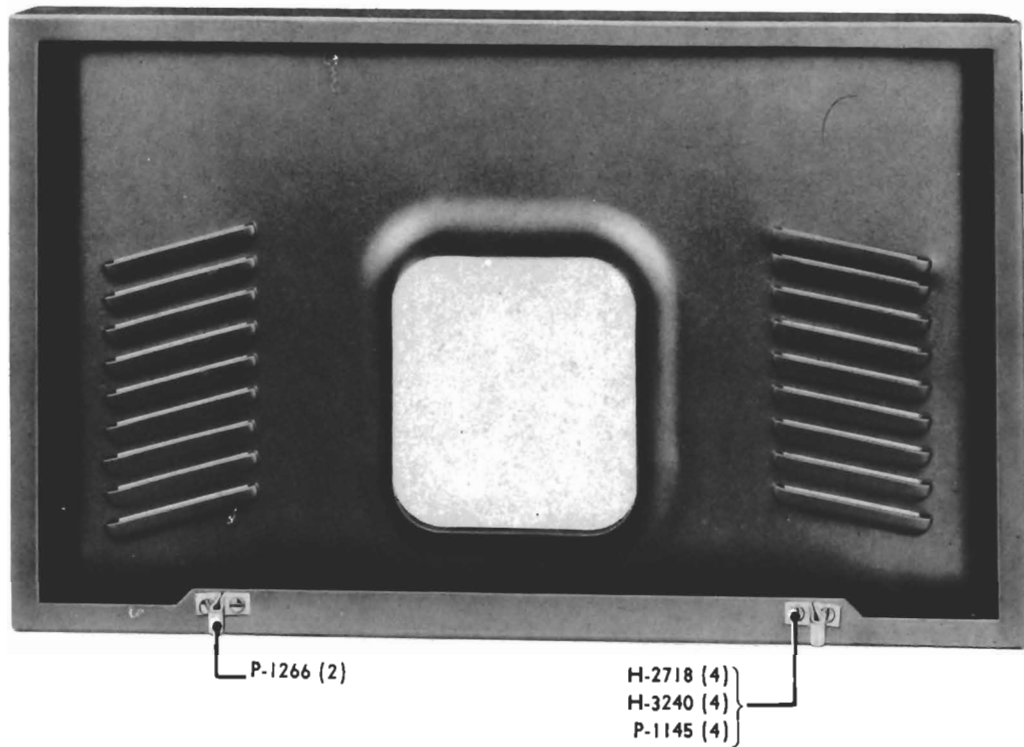

### AM-1034 SYSTEM CABINET

G-2058 Cabinet

G-2097 Cover

H-2714 Door Catch Fastening Screw (4)

H-2718 Door Strike Fastening Screw (4)

H-3101 Nameplate Fastening Screw (2)

H-3226 Door Catch Fastening Nut (4)

H-3240 Door Strike Fastening Nut (4)

H-3255 Pivot-Slide Fastening Nut (6)

H-3441 Door Catch Lockwasher (4)

P-1145 Door Strike Lockwasher (4)

P-1238 Pivot-Slide Lockwasher (6)

P-1266 Door Strike (2)

P-1267 Door Catch (2)

P-2155 Left Chassis Slide

P-2156 Right Chassis Slide

P-2160 Right Slide Stop Lever

P-2161 Chassis Slide Spacer (4)

P-2163 Front Slide Stop Screw (2)

P-2164 Rear Slide Stop Screw (2)

P-2165 Chassis Pivot Screw (2)

P-2167 Stop Lever Fastening Screw (2)

P-2236 Chassis Pivot Screw Spacing Washer (2)

P-2247 Cover Molding (4)

P-2278 Left Slide Stop Lever

P-2765 Nameplate

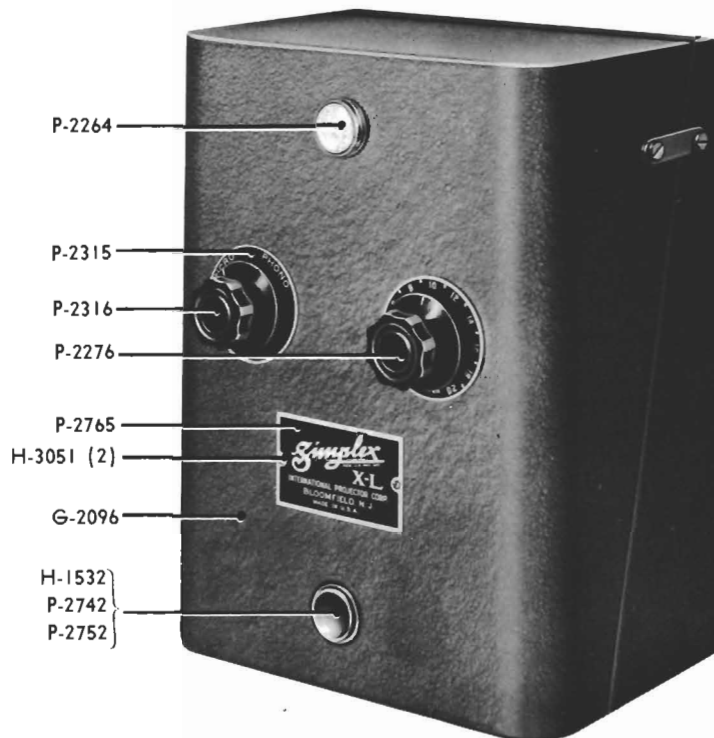

### AM-1035 NON-SYNC. CABINET

G-1941	Terminal Strip	P-1859	Changeover Switch Nut
G-1973	Resistor-Capacitor Mounting Strip	P-2042	Resistor, 10 K, 1 Watt
G-2096	Cabinet (Includes H-3202 (4), P-1145 (4), P-1257 (2), P-1764 (4), P-2987 (2))	P-2048	Resistor, 1 Meg., 1 Watt
G-2118	Cable Form	P-2058	Capacitor, .01 mf, 600 V
G-2165	Frequency Response Reactor	*P-2075	Resistor, 470 Ohms, 1 Watt
H-1532	Changeover Switch Knob	P-2092	Micro-Phono Switch
	Set Screw	*P-2099	Capacitor, .1 mf, 400 V (3)
H-2716	Terminal-Resistor Strip Fastening	P-2110	PEC Amplifier Guide Stud
	Screw (11)	P-2122	Connector, Female
H-3051	License-Nameplate Fastening	P-2264	Pilot Light Socket
	Screw (6)	P-2276	Volume Control, Dial Plate, Knob and Nuts
H-3202	Cabinet Link Screw Fastening	P-2315	Micro-Phono Switch Dial Plate
	Nut (4) (Included with G-2096)	P-2316	Micro-Phono Switch Knob
H-3226	Cable Clamp Fastening Nut	P-2391	License Plate
H-3243	Micro-Phono Switch Fastening	P-2425	Pilot Light, 6-8 V
	Nut (2)	P-2679	Changeover Switch
H-3442	Changeover Switch Lockwasher	P-2742	Changeover Switch Knob
P-1145	Cabinet Link Screw Lockwasher	P-2752	Changeover Switch Knob Spring
	(4) (Included with G-2096)	P-2765	Nameplate
P-1257	Cabinet Link Screw Washer (2)	P-2872	Capacitor, .03 mf, 400 V (4)
	(Included with G-2096)	P-2873	Capacitor, .15 mf, 400 V
P-1278	Terminal-Resistor Strip	P-2875	Resistor, 270 Ohms, 1 Watt
	Lockwasher (11)	*P-2876	Resistor, 120 Ohms, 1 Watt (3)
P-1280	Micro-Phono Switch Lockwasher	P-2878	Capacitor Terminal Strip
P-1764	Cabinet Link Screw (4)	P-2987	Cabinet Link (2)
	(Included with G-2096)	P-2999	(Included with G-2096)
			Cable Clamp

\* P-2075, (2) P-2099, P-2876 are shipped separately with AM-1035 as alternate parts for attenuating and warping networks.

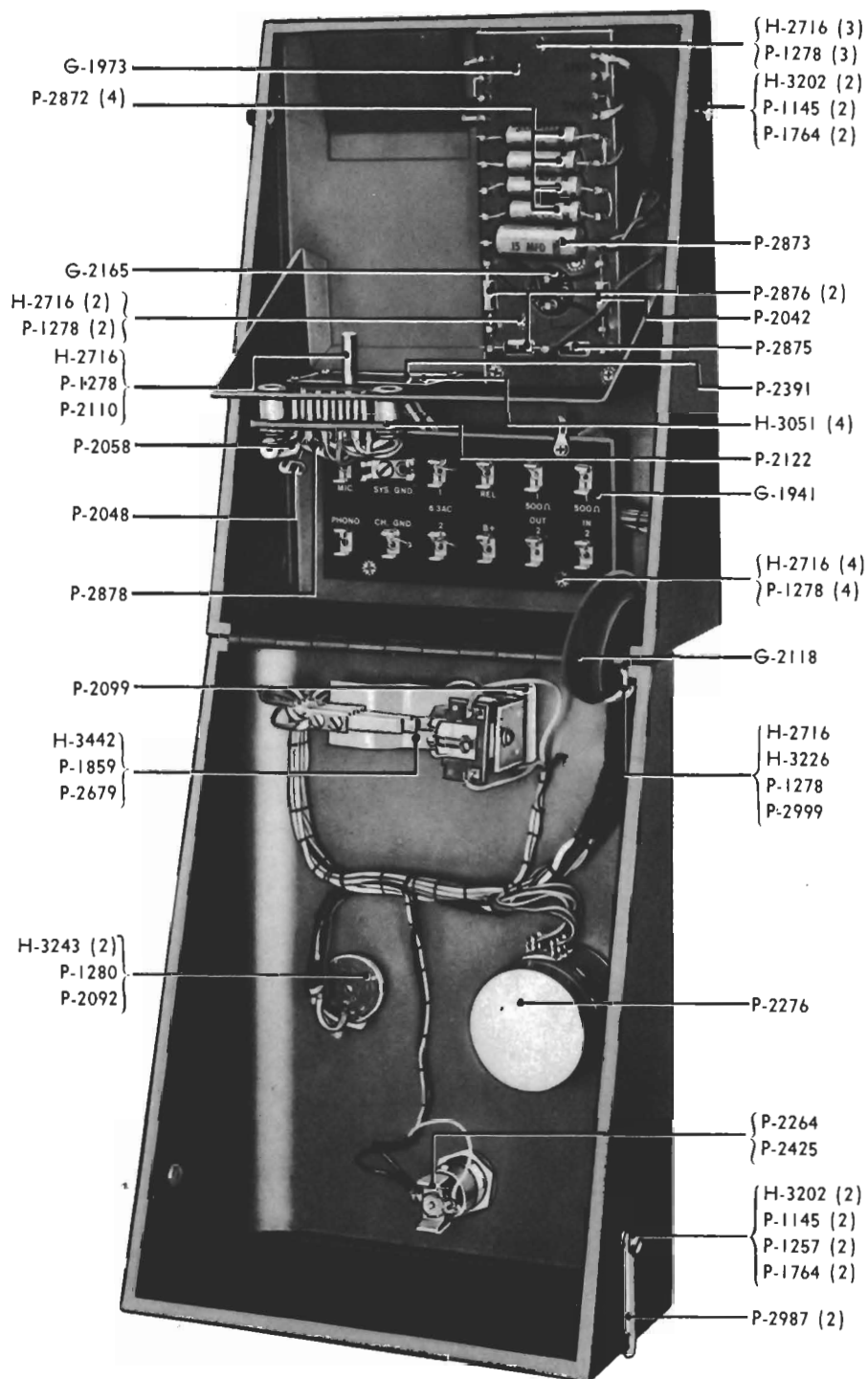

AM-1035 NON-SYNC. CABINET

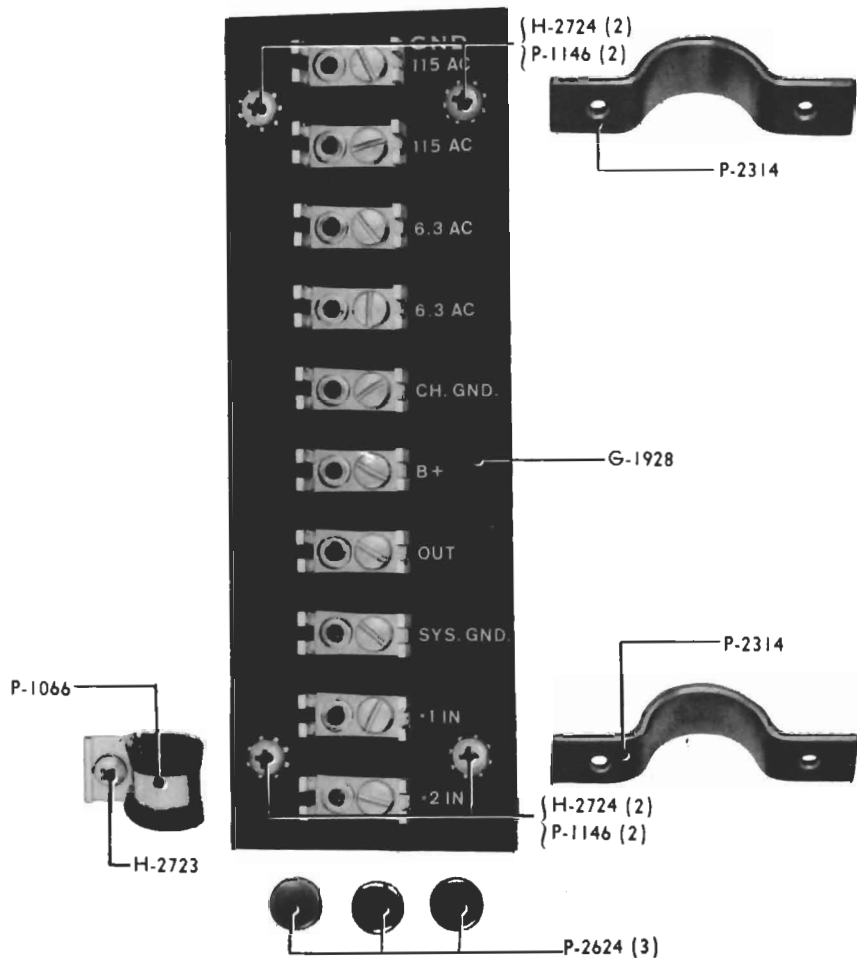

## AM-1037 CABINET KIT

- G-1928 Amplifier Terminal Strip
- H-2723 Cable Clamp Fastening Screw
- H-2724 Terminal Strip Fastening Screw (4)
- P-1066 Amplifier Cable Clamp
- P-1146 Terminal Strip Lockwasher (4)
- P-2314 Terminal Strip Clamp (2)
- P-2624 Apparatus Blank (3)



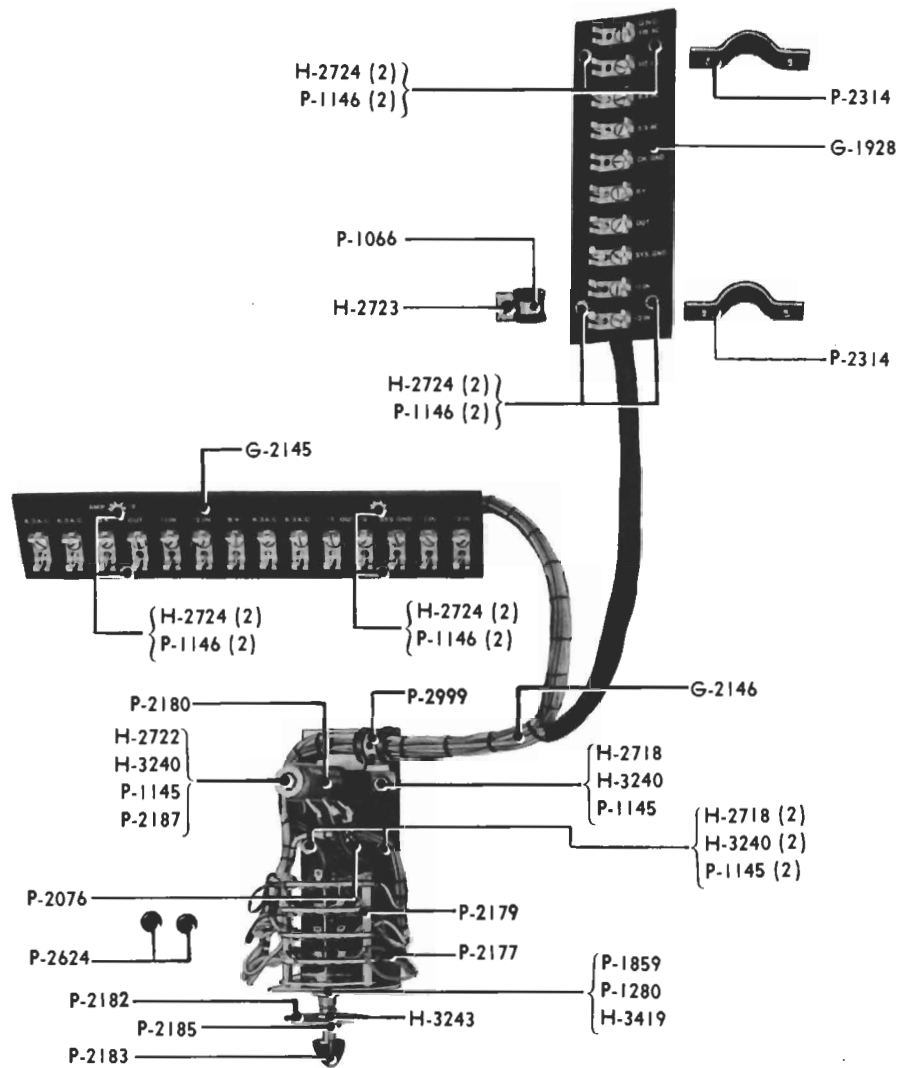

### AM-1038 CABINET KIT

G-1928	Power Amplifier Terminal Strip	P-1145	Switch Bracket-Cable Clamp-Resistor Lockwasher (4)
G-2145	Selector Switch Terminal Strip	P-1146	Terminal Strip Lockwasher (8)
G-2146	Cable Form	P-1280	Switch Lockwasher
H-2718	Switch Bracket-Cable Clamp Fastening Screw (3)	P-1859	Switch Fastening Nut
H-2722	Resistor Mounting Screw	P-2076	Resistor, 0.1 Meg., 2 watt
H-2723	Cable Clamp Fastening Screw	P-2177	Switch Mounting Bracket
H-2724	Terminal Strip Fastening Screw (8)	P-2179	Selector Switch
H-3240	Switch Bracket-Cable Clamp-Resistor Fastening Nut (4)	P-2180	Resistor, 60 ohms, 25 watt
H-3243	Switch Dial Plate Fastening Nut	P-2182	Switch Dial Plate
H-3419	Switch Lockwasher	P-2183	Switch Knob
P-1066	Amplifier Cable Clamp	P-2185	Switch Dial Plate Bushing
		P-2187	Resistor Washer
		P-2314	Terminal Strip Clamp (2)
		P-2624	Apparatus Blank (2)
		P-2999	Switch Cable Clamp

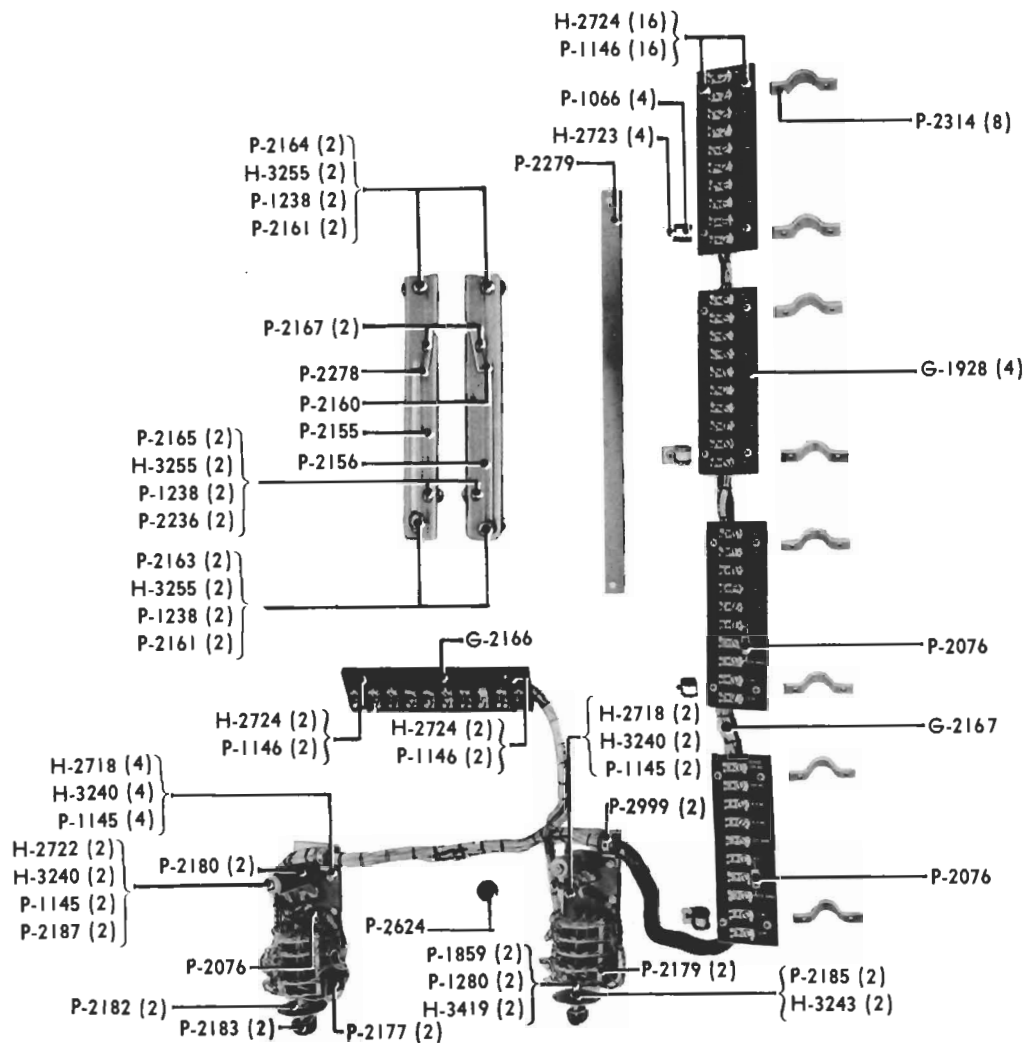

### AM-1039 CABINET KIT

G-1928	Power Amplifier Terminal Strip (4)	P-2076	Resistor, 0.1 Meg., 2 watt (3)
G-2166	Selector Switch Terminal Strip	P-2155	Left Chassis Slide
G-2167	Cable Form	P-2156	Right Chassis Slide
		P-2160	Right Slide Stop Lever
H-2718	Switch Bracket-Cable Clamp	P-2161	Slide Spacing Washer (4)
	Fastening Screw (6)	P-2163	Front Slide Stop Screw (2)
H-2722	Resistor Mounting Screw (2)	P-2164	Rear Slide Stop Screw (2)
H-2723	Cable Clamp Fastening Screw (4)	P-2165	Chassis Pivot Screw (2)
H-2724	Terminal Strip Fastening Screw (20)	P-2167	Stop Lever Fastening Screw (2)
H-3240	Switch Bracket-Cable Clamp-	P-2177	Switch Mounting Bracket (2)
	Resistor Fastening Nut (8)	P-2179	Selector Switch (2)
H-3243	Switch Dial Plate Fastening Nut (2)	P-2180	Resistor, 60 ohms, 25 watt (2)
H-3255	Slide-Pivot Screw Fastening Nut (6)	P-2182	Switch Dial Plate (2)
H-3419	Switch Lockwasher (2)	P-2183	Switch Knob (2)
		P-2185	Switch Dial Plate Bushing (2)
P-1066	Amplifier Cable Clamp (4)	P-2187	Resistor Washer (2)
P-1145	Switch Bracket-Cable Clamp-	P-2236	Chassis Pivot Screw Spacing
	Resistor Lockwasher (8)		Washer (2)
P-1146	Terminal Strip Lockwasher (20)	P-2278	Left Slide Stop Lever
P-1238	Slide-Pivot Screw Lockwasher (6)	P-2279	Cabinet Brace
P-1280	Switch Lockwasher (2)	P-2314	Terminal Strip Clamp (8)
P-1859	Switch Fastening Nut (2)	P-2624	Apparatus Blank
		P-2999	Switch Cable Clamp (2)

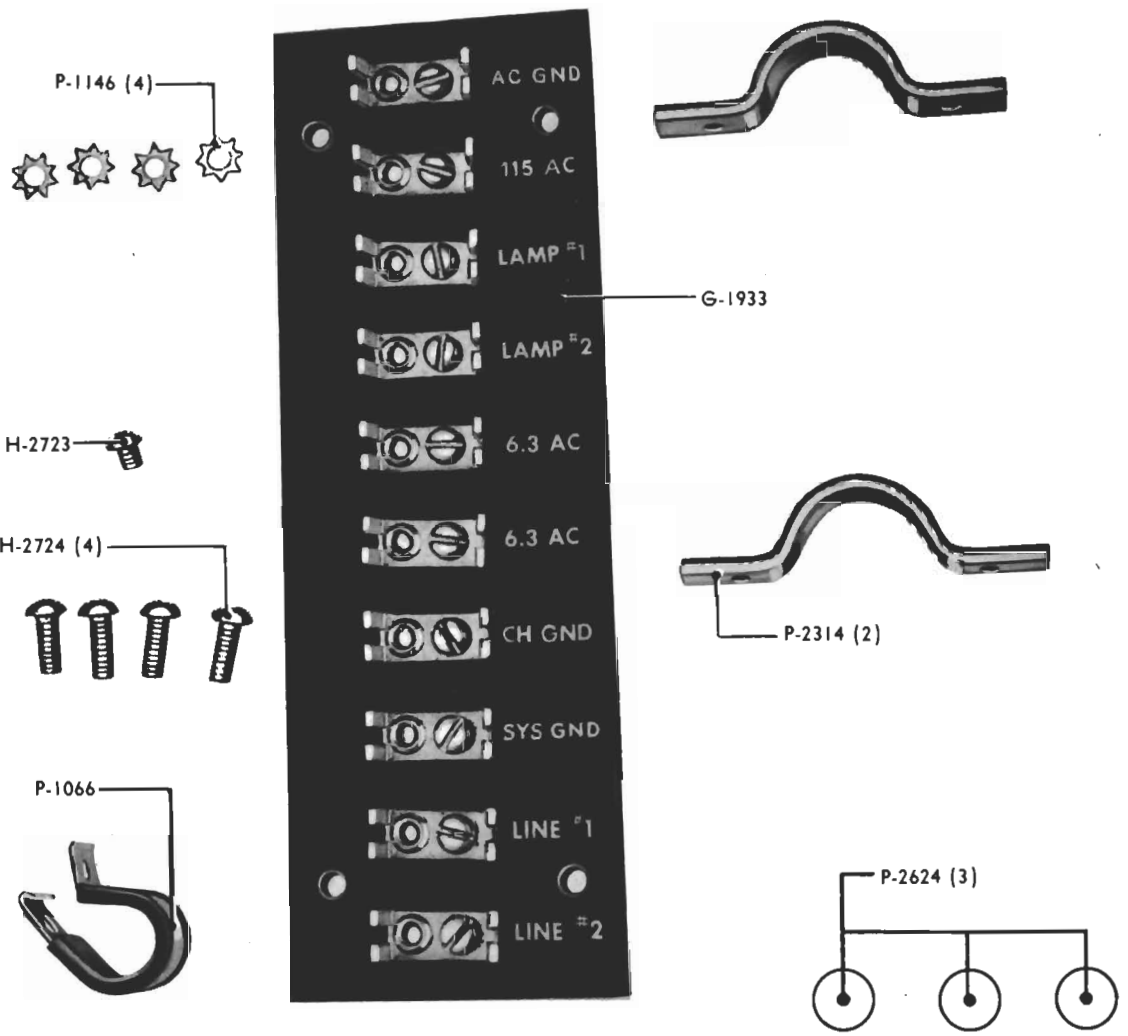

### AM-1050 CABINET KIT

- G-1933 Terminal Strip
- H-2723 Cable Clamp Fastening Screw
- H-2724 Terminal Strip Fastening Screw (4)
- P-1066 Cable Clamp
- P-1146 Terminal Strip Lockwasher (4)
- P-2314 Terminal Strip Clamp (2)
- P-2624 Apparatus Blank (3)

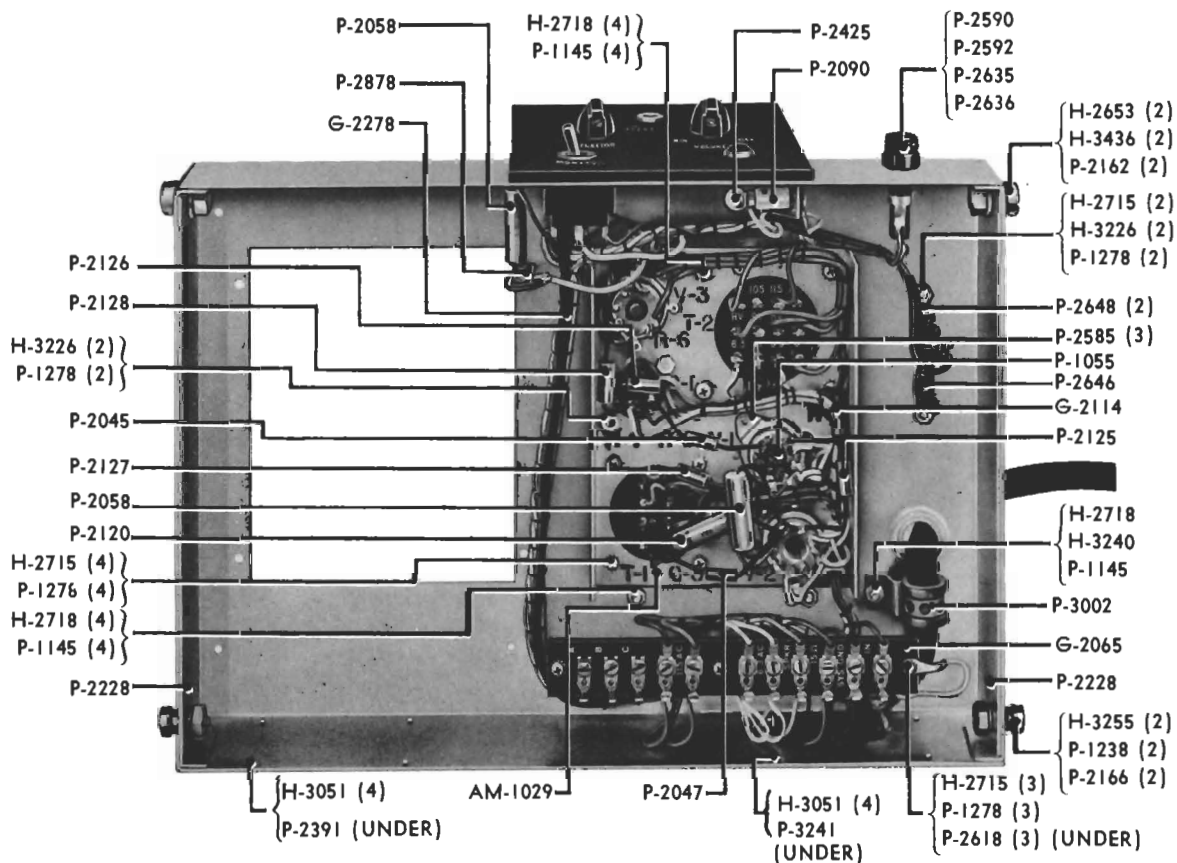
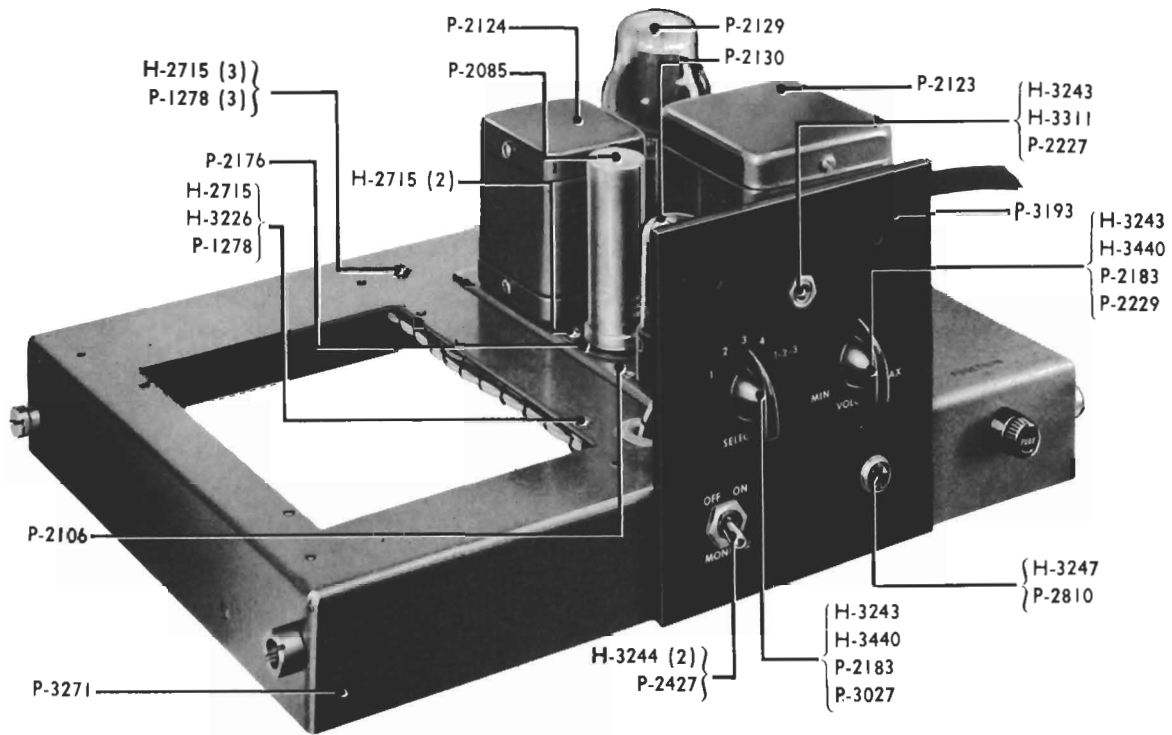

**AM-1054 MONITOR AMPLIFIER AND CONTROL PANEL**  
 (Includes AM-1029 Monitor Amplifier)

## AM-1054 MONITOR AMPLIFIER AND CONTROL PANEL

(Includes AM-1029 Monitor Amplifier)

G-2065	Terminal Strip	P-1238	Chassis Stop Screw Lockwasher (2)
G-2278	Cable Form	P-1278	Terminal-Lug Terminal Strip- Resistor Mounting Bracket Lockwasher (9)
H-2653	Chassis Stop Stud Fastening Screw (2)	P-2058	Capacitor, 0.01 mf, 600 V
H-2715	Terminal-Lug Terminal Strip- Resistor Mounting Bracket Fastening Screw (9)	P-2090	Pilot Light Socket
H-2718	Monitor Amplifier-Cable Clamp Fastening Screw (5)	P-2162	Chassis Stop Stud (2)
H-3051	License-Nameplate Fastening Screw (8)	P-2166	Chassis Stop Screw (2)
H-3226	Lug Terminal Strip-Resistor Mounting Bracket Fastening Nut (3)	P-2183	Selector Switch-Volume Control Knob (2)
H-3240	Cable Clamp Fastening Nut	P-2227	Test Jack
H-3243	Selector Switch-Volume Control- Test Jack Fastening Nut (3)	P-2228	Chassis Reinforcement Plate (2)
H-3244	Monitor Switch Fastening Nut (2)	P-2229	Volume Control
H-3247	Pilot Light Lens Fastening Nut	P-2391	License Plate
H-3255	Chassis Stop Screw Fastening Nut (2)	P-2425	Pilot Light, 6-8 V
H-3311	Test Jack Washer	P-2427	Monitor Switch
H-3436	Chassis Stop Stud Lockwasher (2)	P-2590	Fuseholder
H-3440	Selector Switch-Volume Control Lockwasher (2)	P-2592	Fuse, 1 Amp., Cartridge Fusetron
P-1145	Monitor Amplifier-Cable Clamp Lockwasher (5)	P-2618	Terminal Strip Mounting Stud (3)
		P-2635	Fuseholder Rubber Washer
		P-2636	Fuseholder Fastening Nut
		P-2646	Resistor, 100 Ohms, 10 Watt
		P-2648	Resistor Mounting Bracket (2)
		P-2810	Pilot Light Lens
		P-2878	Lug Terminal Strip
		P-3002	Cable Clamp
		P-3027	Selector Switch
		P-3193	Front Panel
		P-3241	Nameplate
		P-3271	Chassis

## AM-1029 MONITOR AMPLIFIER

G-2114	Cable Form	P-2058	Capacitor, 0.01 mf, 600 V
H-2715	Output Transformer-Capacitor Plate Fastening Screw (6)	P-2085	Capacitor, 20/25, 20/450, 20/450 Electrolytic
H-2718	Power Transformer Fastening Screw (4)	P-2106	Chassis
H-3226	Capacitor Plate Fastening Nut (2)	P-2120	Capacitor, 0.001 mf, 600 V
P-1055	Vacuum Tube, 6SL7-GT	P-2123	Power Transformer
P-1145	Power Transformer Lockwasher (4)	P-2124	Output Transformer
P-1278	Output Transformer-Capacitor Plate Lockwasher (6)	P-2125	Resistor, 1,500 Ohms, 1 Watt
P-2045	Resistor, 0.1 Meg., 1 Watt	P-2126	Resistor, 22,000 Ohms, 1 Watt
P-2047	Resistor, 0.51 Meg., 1 Watt	P-2127	Resistor, 2,700 Ohms, 1 Watt
		P-2128	Resistor, 330 Ohms, 2 Watt
		P-2129	Vacuum Tube, 6L6-G
		P-2130	Vacuum Tube, 5Y3-GT
		P-2176	Capacitor Mounting Plate
		P-2585	Vacuum Tube Socket, Octal (3)

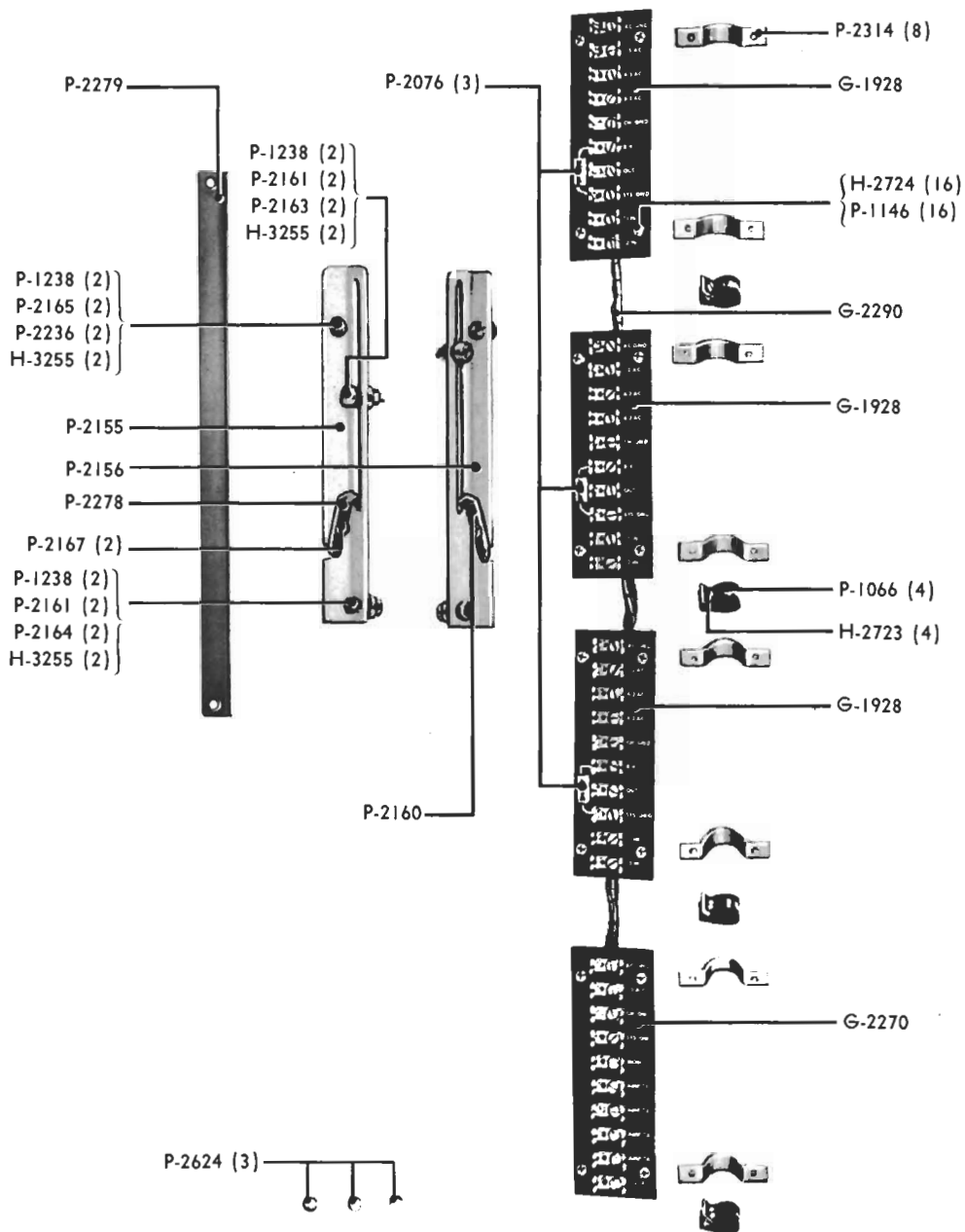

### AM-1055 CABINET KIT

G-1928	Power Amplifier Terminal Strip (3)	P-2076	Resistor, 0.1 Meg., 2 Watt (3)
G-2270	Mon. Ampl. and Control Panel Terminal Strip	P-2155	Left Chassis Slide
G-2290	Cable Form	P-2156	Right Chassis Slide
H-2723	Cable Clamp Fastening Screw (4)	P-2160	Right Slide Stop Lever
H-2724	Terminal Strip Fastening Screw (16)	P-2161	Slide Spacing Washer (4)
H-3255	Slide Pivot Screw Fastening Nut (6)	P-2163	Front Slide Stop Screw (2)
P-1066	Cable Clamp (4)	P-2164	Rear Slide Stop Screw (2)
P-1146	Terminal Strip Lockwasher (16)	P-2165	Chassis Pivot Screw (2)
P-1238	Slide-Pivot Screw Lockwasher (6)	P-2167	Stop Lever Fastening Screw (2)
		P-2236	Chassis Pivot Screw Spacing Washer (2)
		P-2278	Left Slide Stop Lever
		P-2279	Cabinet Brace
		P-2314	Terminal Strip Clamp (8)
		P-2624	Apparatus Blank (3)

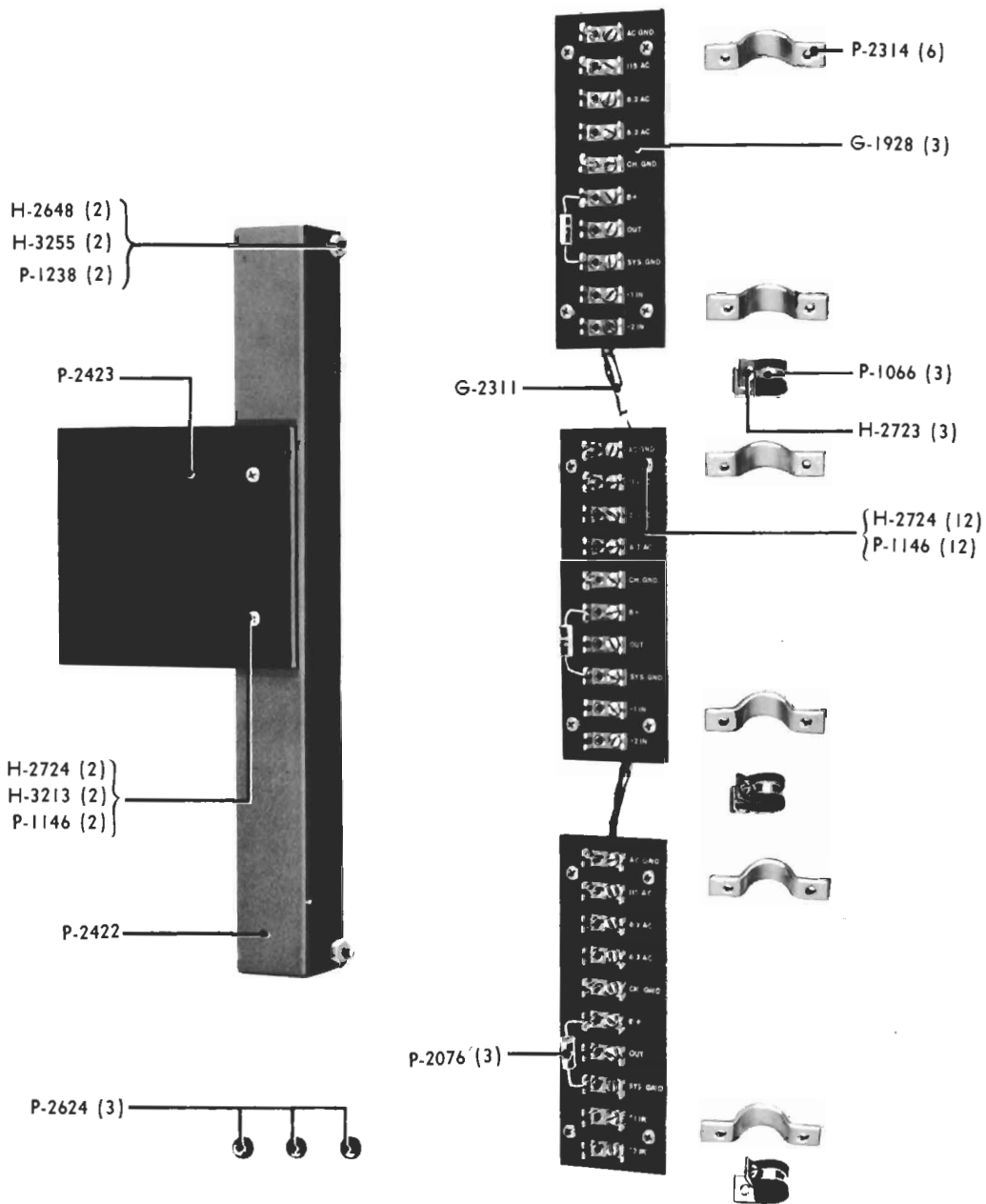

## AM-1059 CABINET KIT

G-1928	Terminal Strip (3)	P-1066	Cable Clamp (3)
G-2311	Cable Form	P-1146	Terminal Strip-Blank Panel Lockwasher (14)
H-2648	Mounting Bracket Fastening Screw (2)	P-1238	Mounting Bracket Lockwasher (2)
H-2723	Cable Clamp Fastening Screw (3)	P-2076	Resistor, 100 K, 2 Watt (3)
H-2724	Terminal Strip-Blank Panel Fastening Screw (14)	P-2314	Terminal Strip Clamp (6)
H-3213	Blank Panel Fastening Nut (2)	P-2422	Blank Panel Mounting Bracket
H-3255	Mounting Bracket Fastening Nut (2)	P-2423	Blank Panel
		P-2624	Apparatus Blank (3)

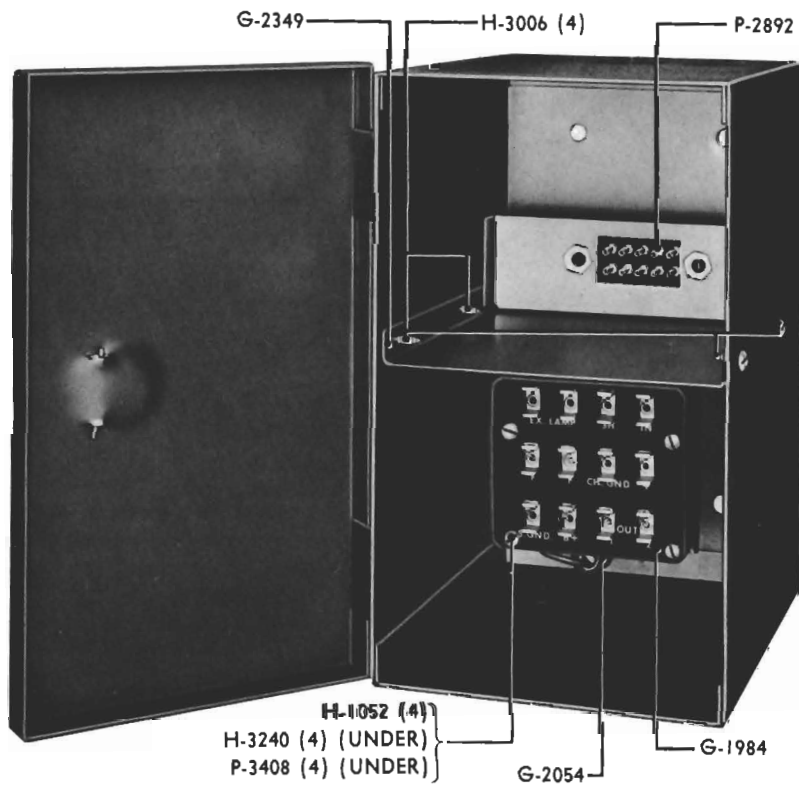
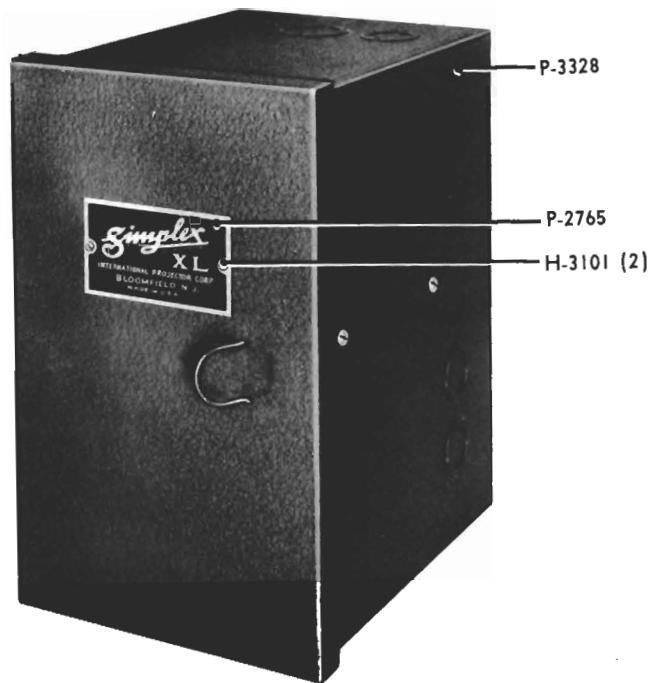

AM-1060 PEC AMPLIFIER CABINET



## AM-1060 PEC AMPLIFIER CABINET

G-1984	Terminal Strip
G-2054	Cable Form
G-2349	Terminal Strip & Connector Mounting Bracket
H-1052	Terminal Strip Fastening Screw (4)
H-3006	Terminal Strip & Connector Mounting Bracket Fastening Screws (4)
H-3101	Nameplate Fastening Screw (2)
H-3240	Terminal Strip Fastening Nut (4)
P-2765	Nameplate
P-2892	Connector, Female
P-3328	Cabinet
P-3408	Terminal Strip Spacer (4)

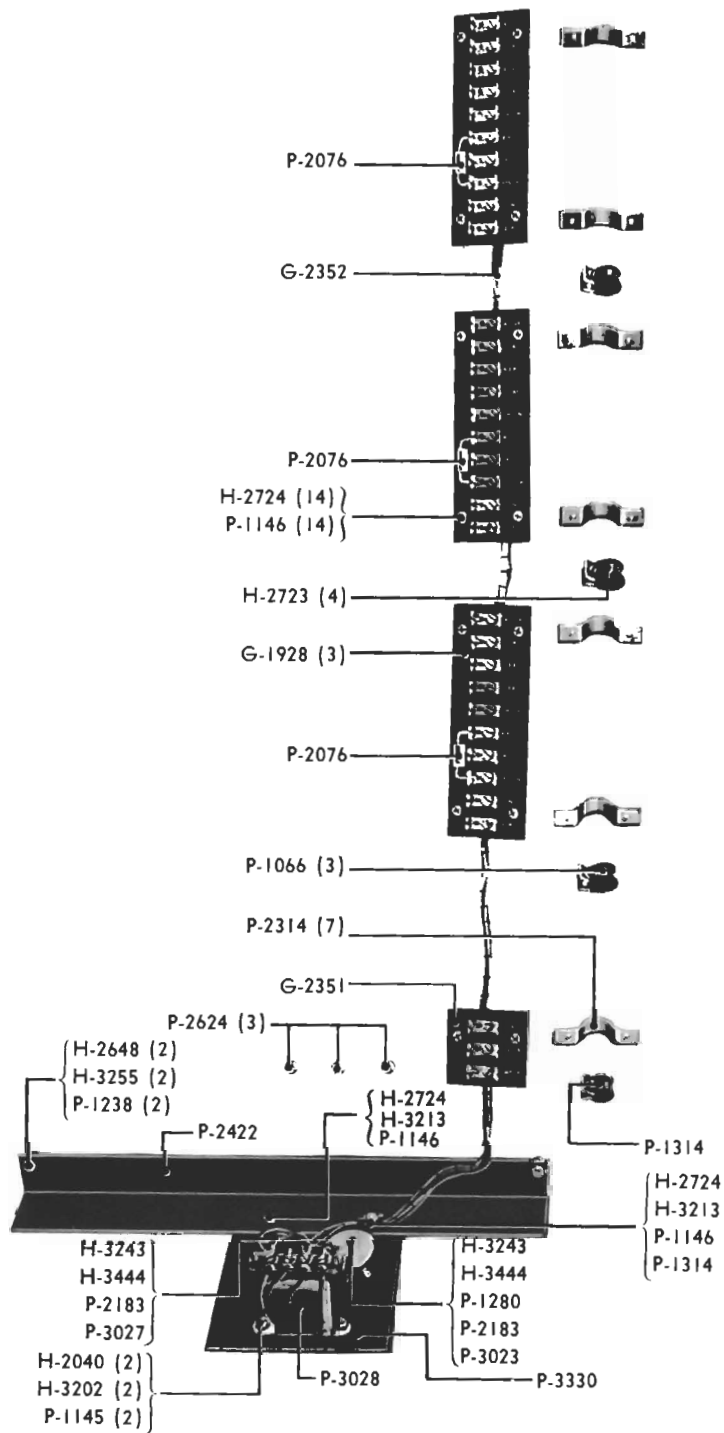

AM-1062 MONITOR PANEL AND SYSTEM CABINET KIT

## AM-1062 MONITOR PANEL AND SYSTEM CABINET KIT

G-1928	Power Amplifier Terminal Strip (3)
G-2351	Monitor Panel Terminal Strip
G-2352	Cable Form
H-2040	Transformer Fastening Screw (2)
H-2648	Mounting Bracket Fastening Screw (2)
H-2723	Cable Clamp Fastening Screw (4)
H-2724	Terminal Strip-Front Panel Fastening Screw (16)
H-3202	Transformer Fastening Nut (2)
H-3213	Front Panel Fastening Nut (2)
H-3243	Volume Control-Selector Switch Fastening Nut (2)
H-3255	Mounting Bracket Fastening Nut (2)
H-3444	Volume Control-Selector Switch Lockwasher (2)
P-1066	Cable Clamp, 1/2" Opening (3)
P-1145	Transformer Lockwasher (2)
P-1146	Terminal Strip-Front Panel Lockwasher (16)
P-1238	Mounting Bracket Lockwasher (2)
P-1280	Volume Control Lockwasher
P-1314	Cable Clamp, 1/4" Opening (2)
P-2076	Resistor, 0.1 Meg., 2 Watt (3)
P-2183	Volume Control-Selector Switch Knob (2)
P-2314	Terminal Strip Clamp (7)
P-2422	Front Panel Mounting Bracket
P-2624	Apparatus Blank (3)
P-3023	Volume Control
P-3027	Selector Switch
P-3028	Transformer
P-3330	Front Panel

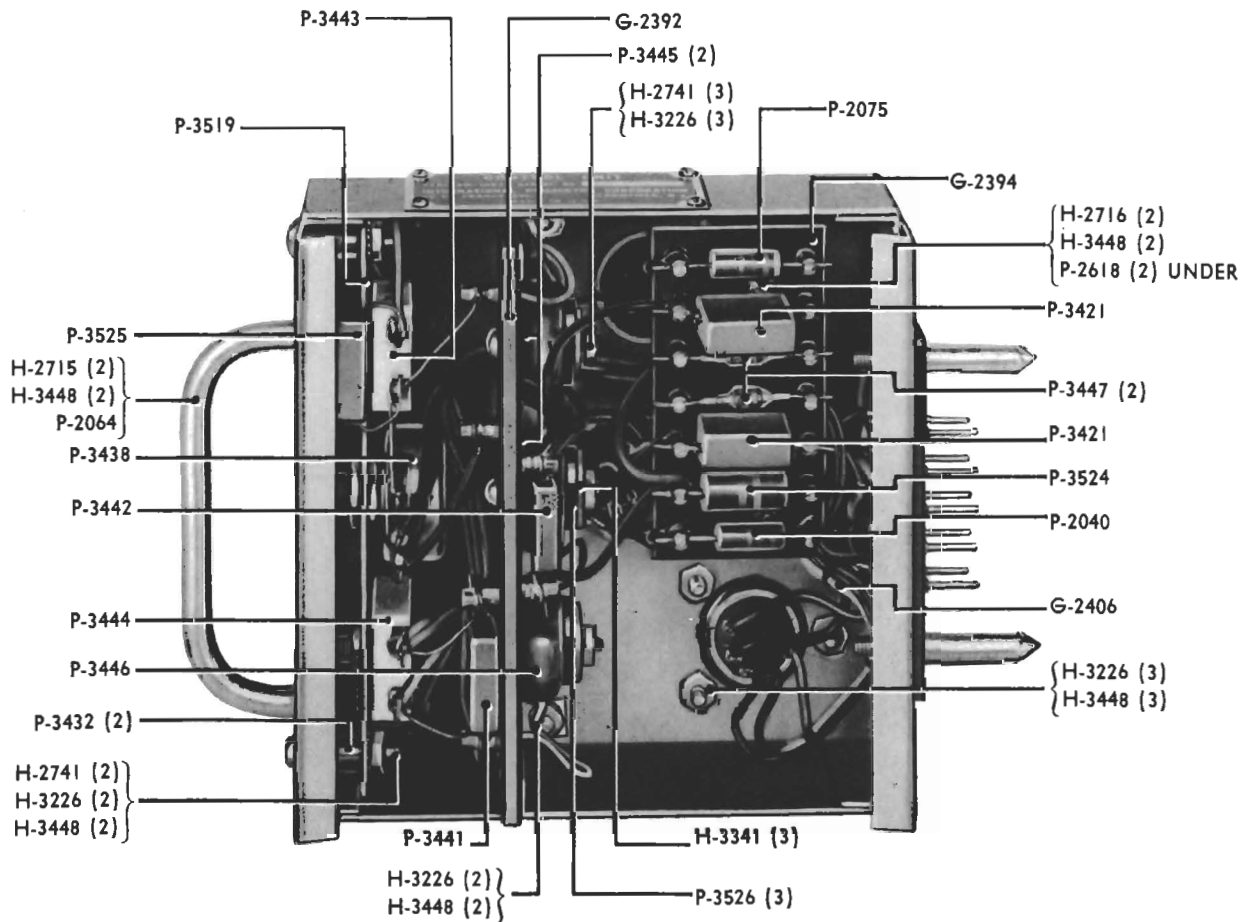
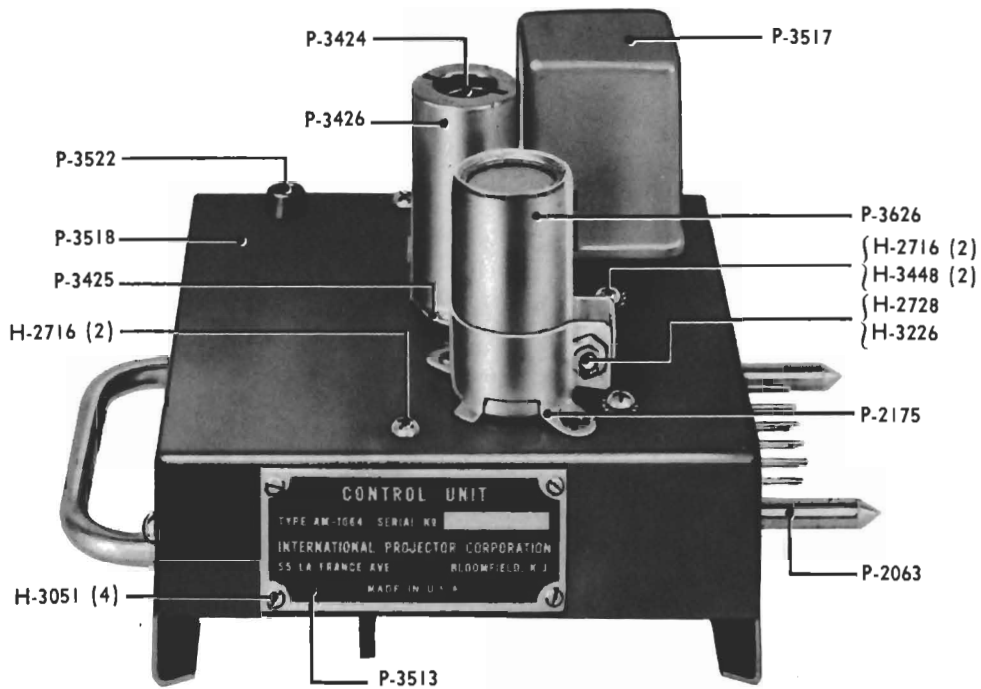

AM-1064 CONTROL UNIT

## AM-1064 CONTROL UNIT

G-2392	Inductor Mounting Strip
G-2394	Resistor Mounting Strip and Lugs
G-2406	Cable Form
H-2715	Handle Fastening Screw (2)
H-2716	Inductor-Resistor Mounting Strip-Stud Fastening Screw (6)
H-2728	Capacitor Mounting Ring Clamping Screw
H-2741	Inductor-Inductor Mounting Strip Fastening Screw (5)
H-3051	Nameplate Fastening Screw (4)
H-3226	Relay-Inductor-Mounting Plate-Strip-Clamping Screw Fastening Nut (11)
H-3341	Inductor Retaining Washer, Metal (3)
H-3448	Relay-Inductor-Mounting Plate-Strip-Stud-Handle Lockwasher (13)
P-2040	Resistor, 510 Ohms, 1 Watt
P-2063	Panel Connector, Male
P-2064	Handle
P-2075	Resistor, 470 Ohms, 1 Watt
P-2175	Capacitor Mounting Ring
P-2618	Resistor Mounting Strip Mounting Studs (2)
P-3421	Capacitor, .01 mf, 500 V (2)
P-3424	Vacuum Tube, 12AT7
P-3425	Vacuum Tube Socket, 9 Pin Min.
P-3426	Vacuum Tube Shield
P-3432	Capacitor-Potentiometer Mounting Plate Spacer (2)
P-3438	Potentiometer, 1 Meg., 2 Watt
P-3441	Capacitor, .0047 mf, 500 V
P-3442	Capacitor, .0012 mf, 500 V
P-3443	Capacitor, 100-500 mmf, Variable
P-3444	Capacitor, 550-1600 mmf, Variable
P-3445	Inductor, 150 MH (2)
P-3446	Inductor, 30 MH
P-3447	Germanium Diode IN 34-A (2)
P-3513	Nameplate
P-3517	Relay
P-3518	Chassis
P-3519	Capacitor-Potentiometer Mounting Plate
P-3522	Test Jack
P-3524	Resistor, 15 K, 2 Watt
P-3525	Capacitor, 750 mmf, 500 V
P-3526	Inductor Retaining Washer, Fibre (3)
P-3626	Capacitor, 25 mf, 50 V

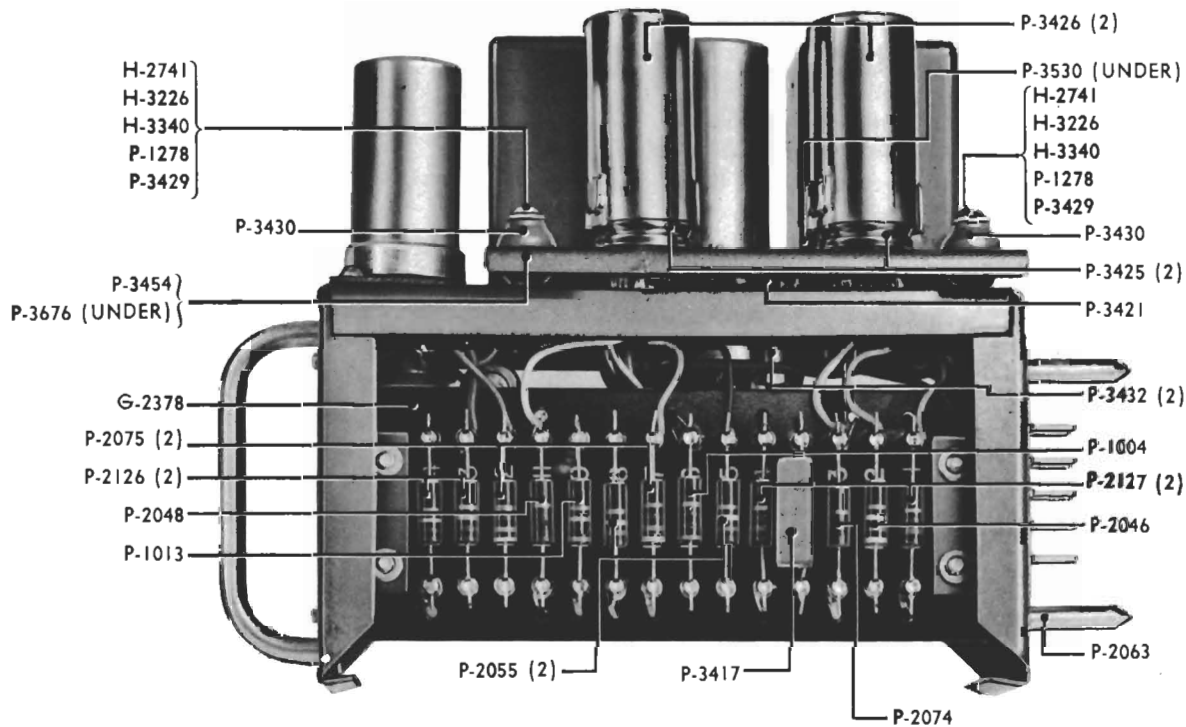
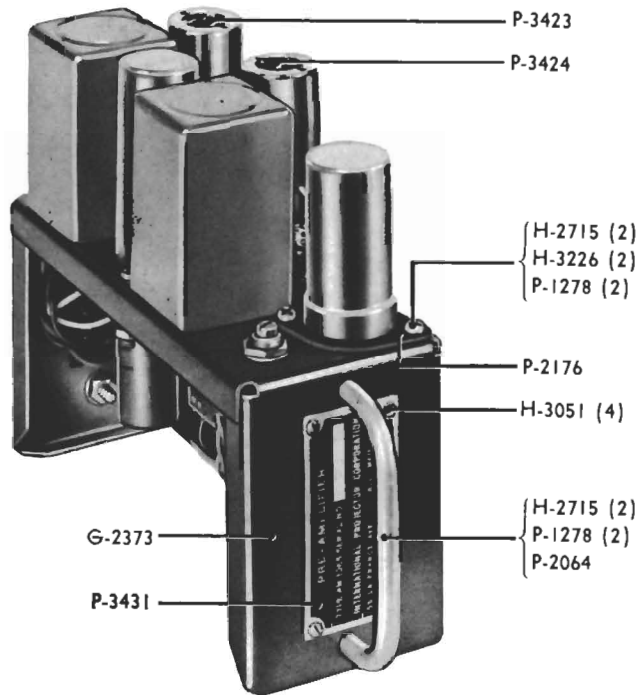

AM-1065 PRE-AMPLIFIER

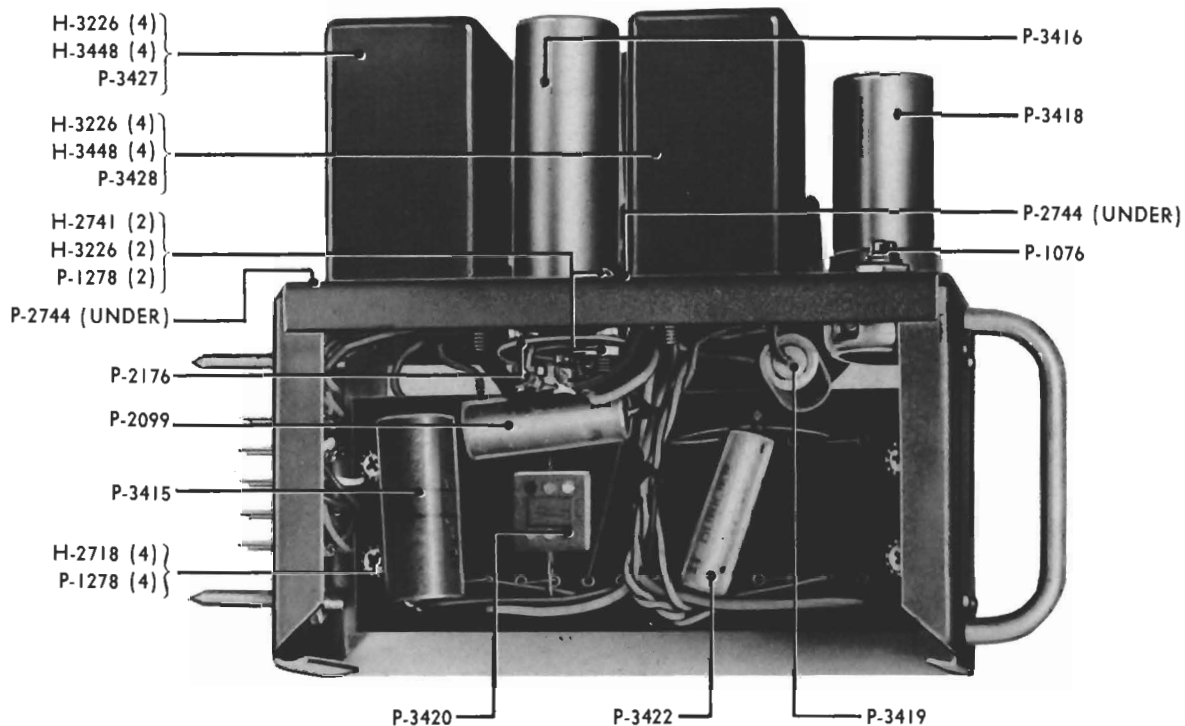

### AM-1065 PRE-AMPLIFIER

G-2373	Chassis	P-2126	Resistor, 22 K, 1 Watt (2)
G-2378	Mounting Strip and Lugs	P-2127	Resistor, 2700 Ohms, 1 Watt (2)
H-2715	Capacitor Mounting Plate-Handle	P-2176	Capacitor Mounting Plate (2)
	Fastening Screw (4)	P-2744	Terminal Lug (2)
H-2718	Mounting Strip Fastening Screw (4)	P-3415	Capacitor, 500 mf, 6 V, Electrolytic
H-2741	Capacitor-Vacuum Tube Socket	P-3416	Capacitor, 20 mf/450 V,
	Mounting Plate Fastening		20 mf/450 V Electrolytic
	Screw (4)	P-3417	Capacitor, .015 mf, 300 V
H-3051	Nameplate Fastening Screw (4)	P-3418	Capacitor, 100 mf/10 V,
H-3226	Transformer-Capacitor-Vacuum		100 mf/10 V Electrolytic
	Tube Socket Mounting Plate	P-3419	Capacitor, .25 mf, 600 V Metalized
	Fastening Nut (14)	P-3420	Capacitor, .0039 mf, 500 V
H-3340	Vacuum Tube Socket Mounting	P-3421	Capacitor, .01 mf, 500 V
	Plate Washer (2)	P-3422	Capacitor, .05 mf, 400 V
H-3448	Transformer Lockwasher (8)	P-3423	Vacuum Tube, 5879
P-1004	Resistor, 750 Ohms, 1 Watt	P-3424	Vacuum Tube, 12AT7
P-1013	Resistor, 75 K, 1 Watt	P-3425	Vacuum Tube Socket (2)
P-1076	Potentiometer, 100 K, 2 Watt	P-3426	Vacuum Tube Shield (2)
P-1278	Handle-Capacitor-Vacuum Tube	P-3427	Input Transformer
	Socket Mounting Plate-	P-3428	Output Transformer
	Mounting Strip Lockwasher (12)	P-3429	Vacuum Tube Mounting Plate
P-2046	Resistor, 470 K, 1 Watt	P-3430	Spacer (2)
P-2048	Resistor, 1 Meg., 1 Watt		Vacuum Tube Mounting Plate
P-2055	Resistor, 270 K, 1 Watt (2)	P-3431	Shock Mount (2)
P-2063	Panel Connector, Male	P-3432	Nameplate
P-2064	Handle		Capacitor Mounting Plate
P-2074	Resistor, 2 Meg., 1 Watt	P-3454	Spacer (2)
P-2075	Resistor, 470 Ohms, 1 Watt (2)		Vacuum Tube Socket Mounting
P-2099	Capacitor, .1 mf, 400 V	P-3530	Plate
		P-3676	Terminal Lug
			Insulation Strip

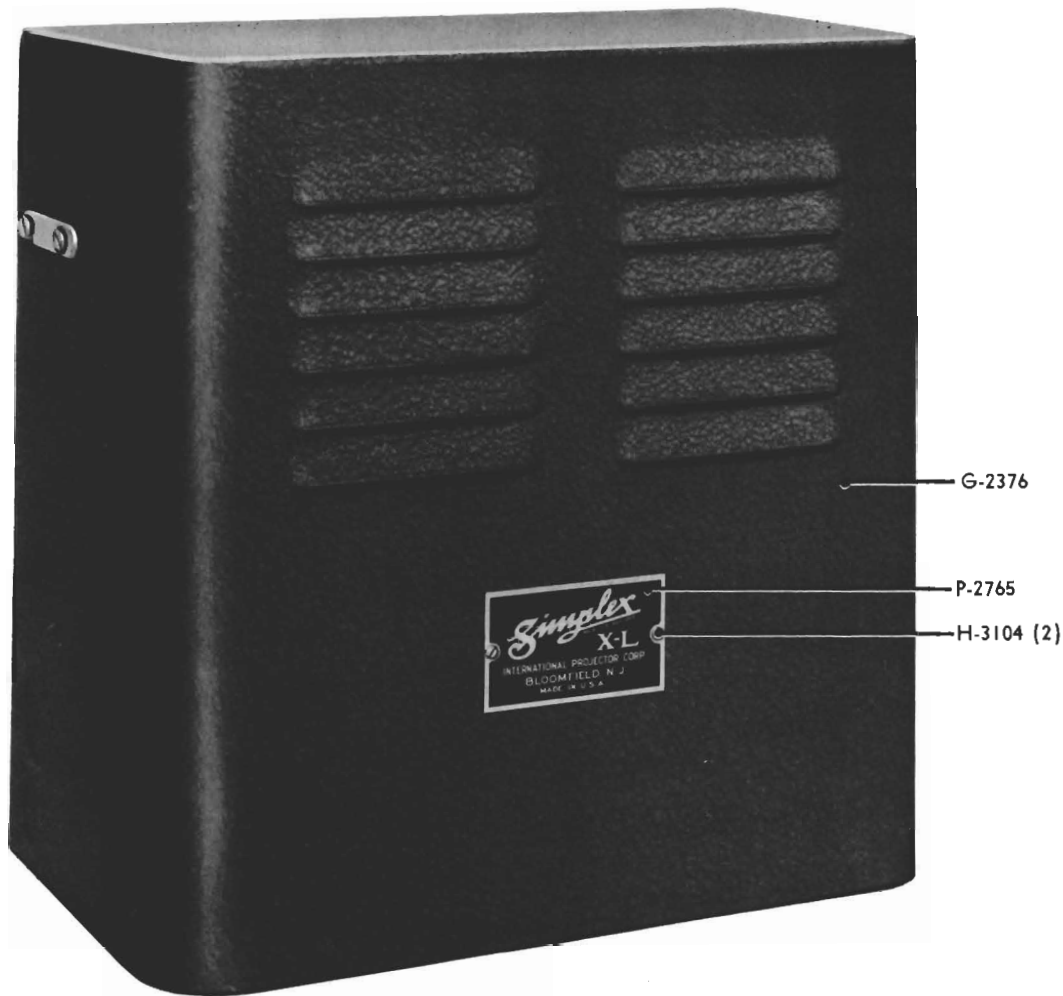

## AM-1066 PRE-AMPLIFIER CABINET

G-2376	Cabinet (Includes H-3104 (6), H-3202 (2), P-1145 (4), P-1257 (2), P-1764 (4), P-2391, P-2765, P-2987 (2))
G-2379	Terminal Strip
G-2380	Cable Form
H-2725	Terminal Strip Fastening Screw (4)
H-3104	Name-License Plate Fastening Screw (6) (Included with G-2376)
H-3202	Cabinet Link Screw Fastening Nut (4) (Included with G-2376)
H-3445	Terminal Strip Lockwasher (4)
P-1145	Cabinet Link Screw Lockwasher (4) (Included with G-2376)
P-1257	Cabinet Link Screw Washer (2) (Included with G-2376)
P-1764	Cabinet Link Screw (4) (Included with G-2376)
P-2122	Female Connector (4)
P-2391	License Plate (Included with G-2376)
P-2765	Nameplate (Included with G-2376)
P-2987	Cabinet Link (2) (Included with G-2376)



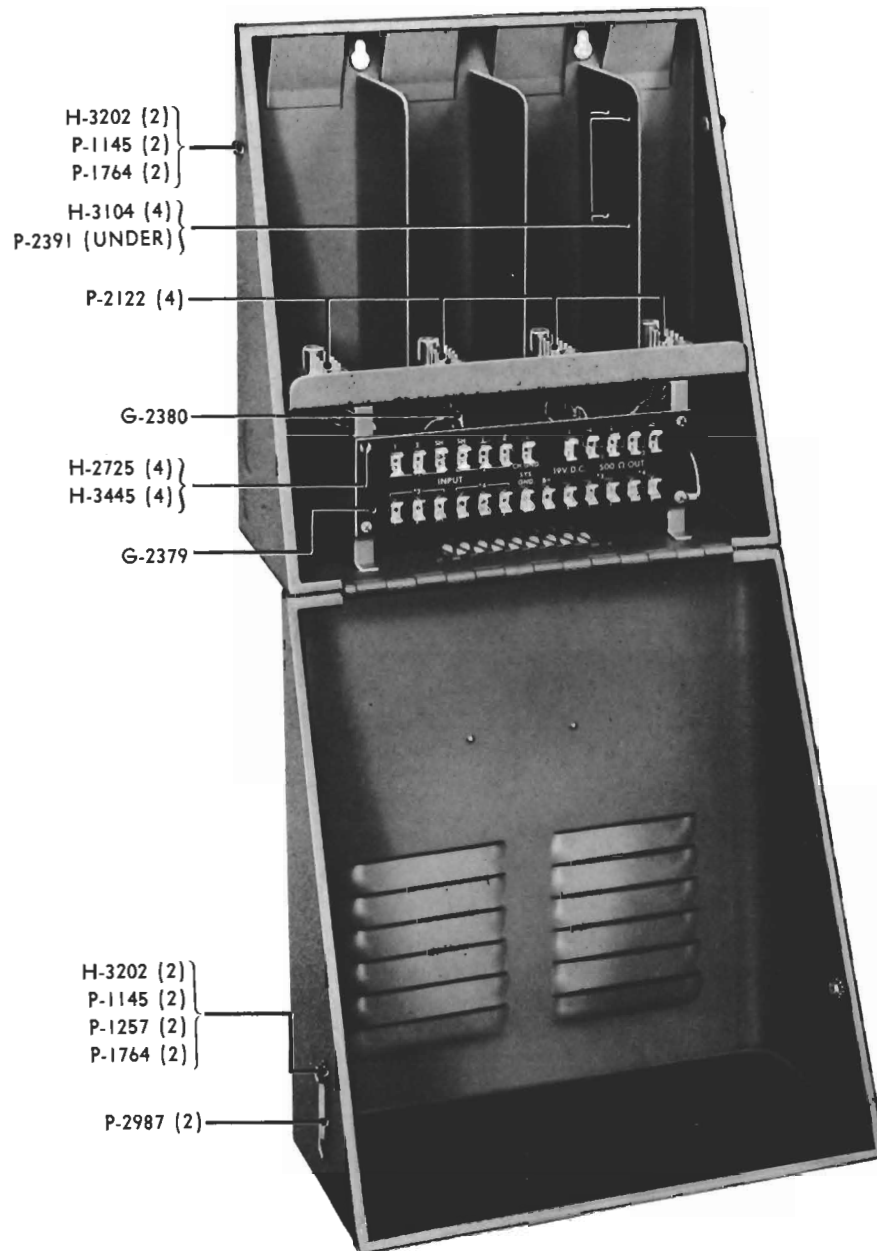

H-3202 (2)  
 P-1145 (2)  
 P-1764 (2)

H-3104 (4)  
 P-2391 (UNDER)

P-2122 (4)

G-2380

H-2725 (4)  
 H-3445 (4)

G-2379

H-3202 (2)  
 P-1145 (2)  
 P-1257 (2)  
 P-1764 (2)

P-2987 (2)

AM-1066 PRE-AMPLIFIER CABINET

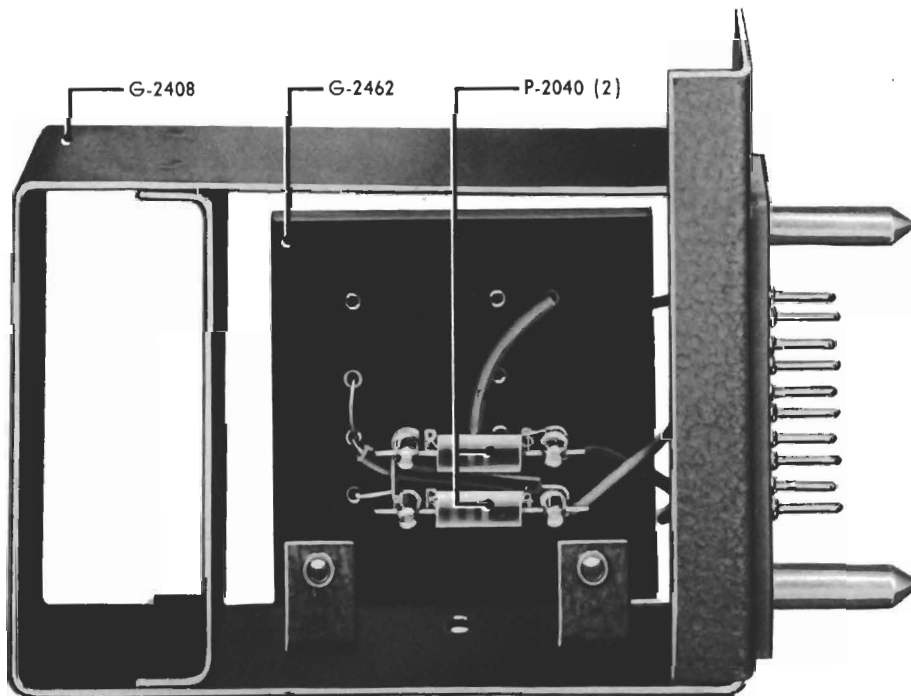
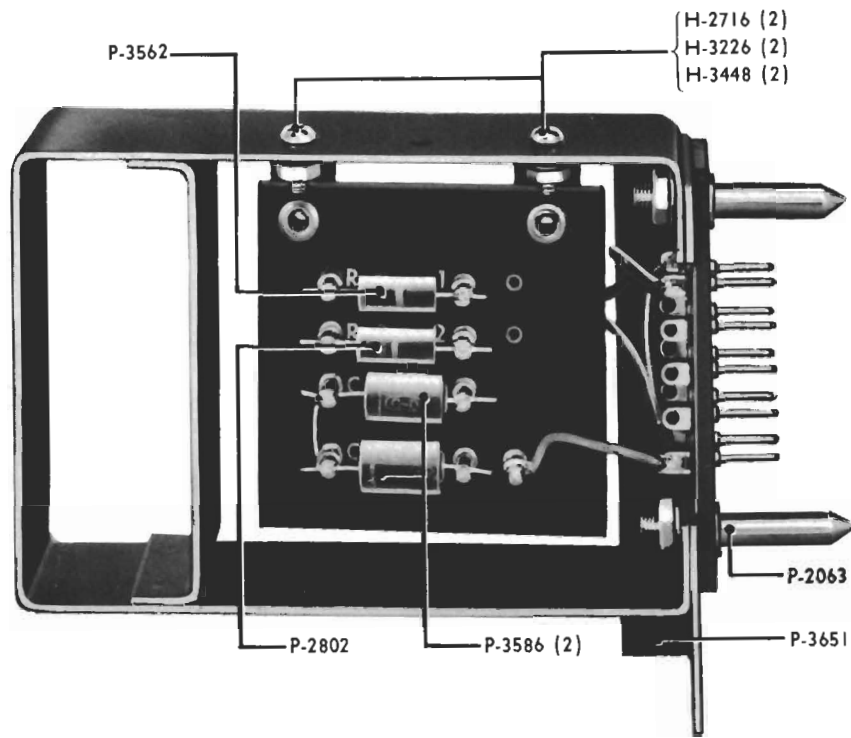

AM-1079 WARPING UNIT

## AM-1079 WARPING UNIT

G-2408	Chassis
G-2462	Resistor-Capacitor Mounting Strip
H-2716	Mounting Strip Fastening Screw (2)
H-3226	Mounting Strip Fastening Nut (2)
H-3448	Mounting Strip Lockwasher (2)
*P-1004	Resistor, 750 Ohms, 1 Watt
P-2040	Resistor, 510 Ohms, 1 Watt (2)
P-2063	Panel Connector, Male
*P-2125	Resistor, 1500 Ohms, 1 Watt
P-2802	Resistor, 300 Ohms, 1 Watt
*P-3561	Resistor, 160 Ohms, 1 Watt
P-3562	Resistor, 820 Ohms, 1 Watt
*P-3563	Resistor, 330 Ohms, 1 Watt
P-3586	Capacitor, .1 mf, 200 V (2)
*P-3587	Capacitor, .15 mf, 200 V (2)
P-3651	Tie Bracket

\* Shipped separately with AM-1079 as alternate parts for attenuating and warping networks.

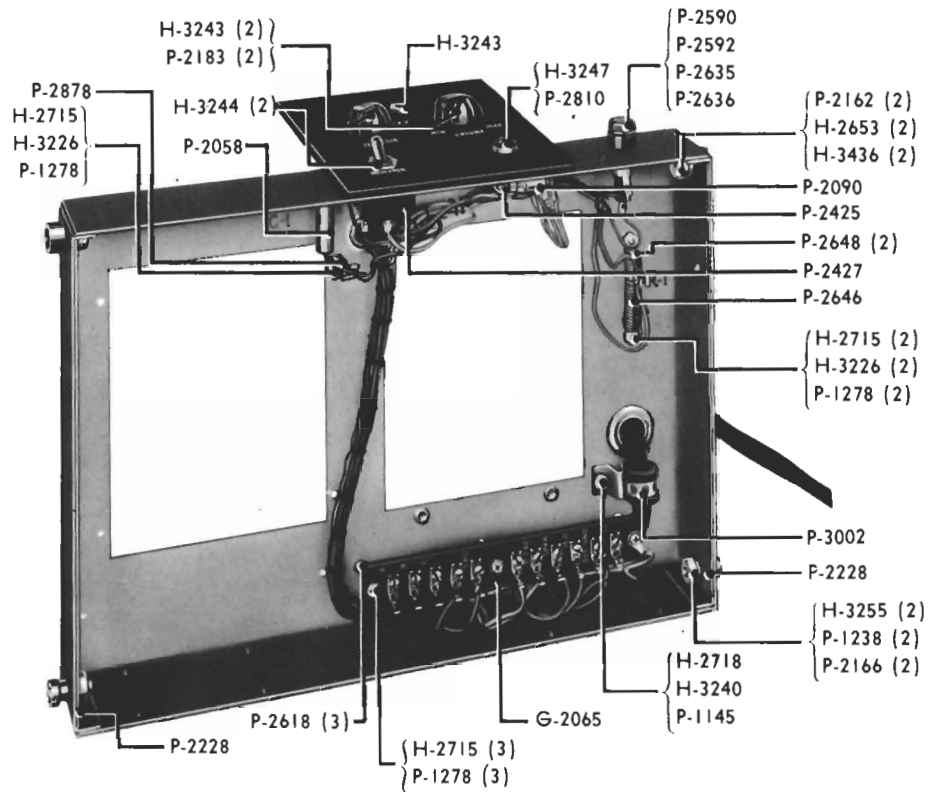
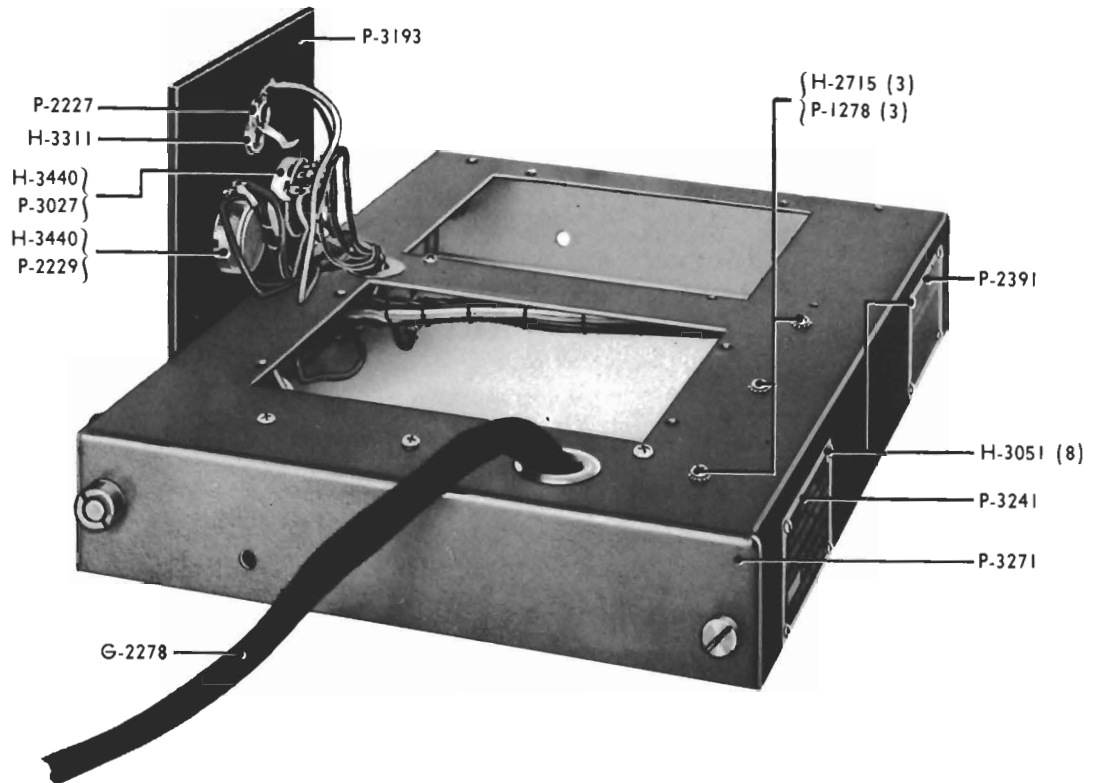

AM-1081 MONITOR CONTROL PANEL

## AM-1081 MONITOR CONTROL PANEL

G-2065	Terminal Strip
G-2278	Cable Form
H-2653	Chassis Stop Stud Fastening Screw (2)
H-2715	Terminal Strip-Stud-Resistor Mounting Bracket Fastening Screw (9)
H-2718	Cable Clamp Fastening Screw
H-3051	License-Nameplate Fastening Screw (8)
H-3226	Terminal Strip-Resistor Mounting Bracket Fastening Nut (3)
H-3240	Cable Clamp Fastening Nut
H-3243	Test Jack-Selector Switch-Volume Control Fastening Nut (3)
H-3244	Power Switch Fastening Nut (2)
H-3247	Pilot Light Lens Fastening Nut
H-3255	Chassis Stop Screw Fastening Nut (2)
H-3311	Test Jack Washer
H-3436	Chassis Stop Stud Lockwasher (2)
H-3440	Selector Switch-Volume Control Lockwasher (2)
P-1145	Cable Clamp Lockwasher
P-1238	Chassis Stop Screw Lockwasher (2)
P-1278	Terminal Strip-Stud-Resistor Mounting Bracket Lockwasher (9)
P-2058	Capacitor, .01 mf, 600 V
P-2090	Pilot Light Socket
P-2162	Chassis Stop Stud (2)
P-2166	Chassis Stop Screw (2)
P-2183	Selector Switch-Volume Control Knob (2)
P-2227	Test Jack
P-2228	Chassis Reinforcement Plate (2)
P-2229	Volume Control
P-2391	License Plate
P-2425	Pilot Light, 6-8 V
P-2427	Power Switch
P-2590	Fuseholder
P-2592	Fuse, 1 Amp., Cartridge Fusetron
P-2618	Terminal Strip Stud (3)
P-2635	Fuseholder Rubber Washer
P-2636	Fuseholder Fastening Nut
P-2646	Resistor, 100 Ohms, 10 Watt, Adjustable
P-2648	Resistor Mounting Bracket (2)
P-2810	Pilot Light Lens
P-2878	Terminal Strip, Lug
P-3002	Cable Clamp
P-3027	Selector Switch
P-3193	Front Panel
P-3241	Nameplate
P-3271	Chassis

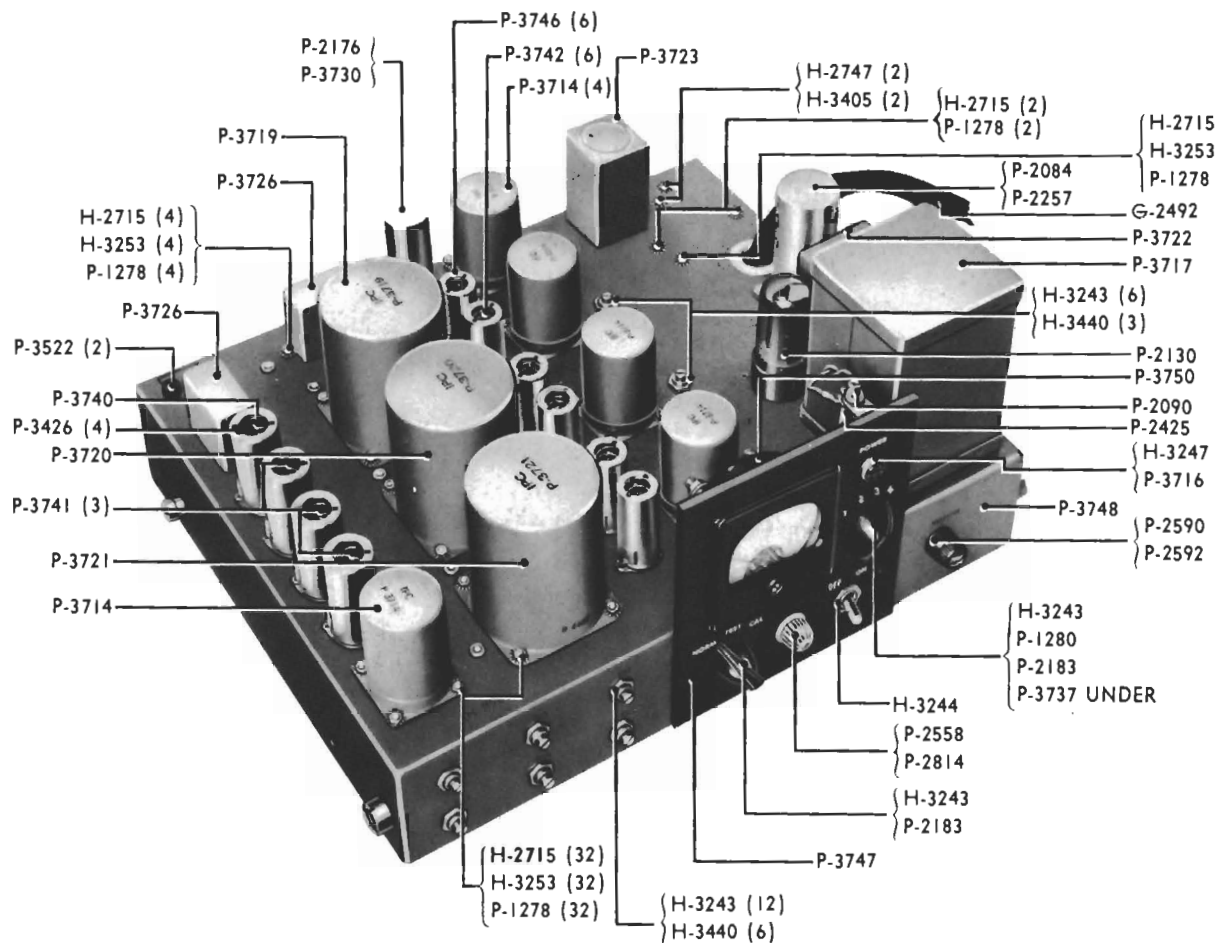

AM-1150 CONTROL UNIT  
(PERSPECTA SOUND)

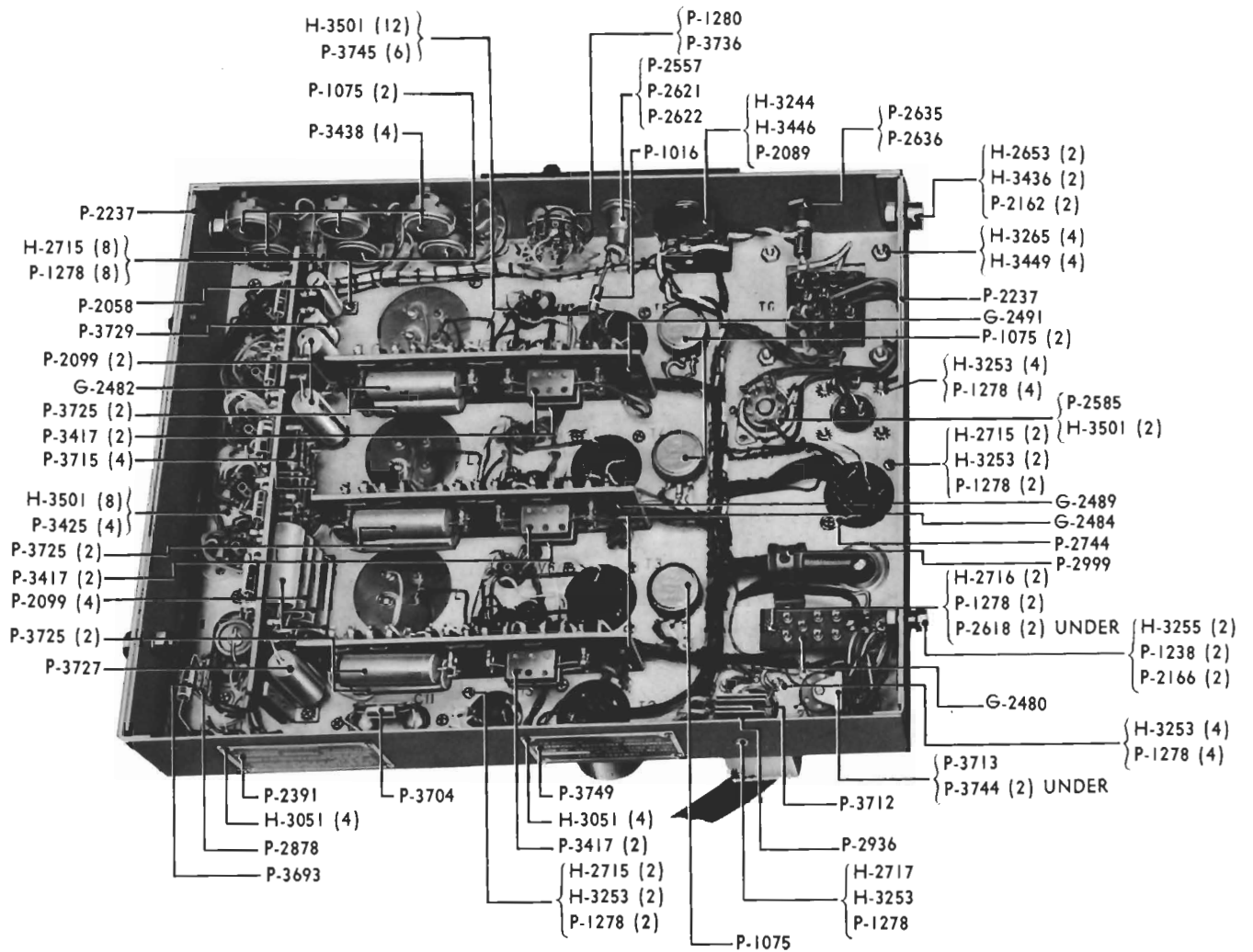

AM-1150 CONTROL UNIT  
 (PERSPECTA SOUND)

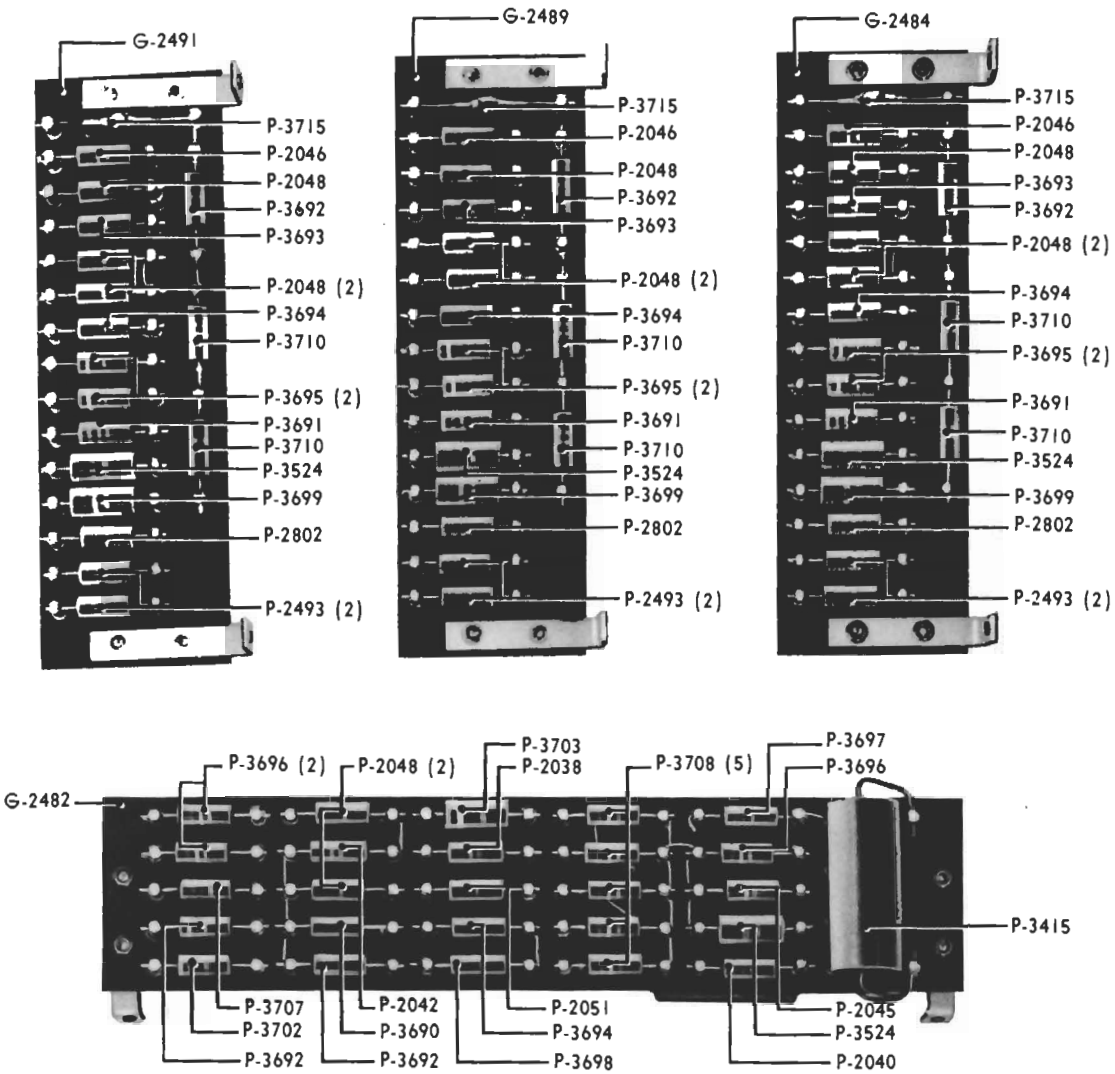

G-2482, G-2484, G-2489, G-2491 MOUNTING STRIPS AND RESISTORS

AM-1150 CONTROL UNIT  
(PERSPECTA SOUND)



**AM-1150 CONTROL UNIT**  
(Perspecta Sound)

G-2480	Terminal Strip	P-2558	Neon Indicator Light
G-2482	Resistor-Capacitor Mounting Strip and Lugs	P-2585	Vacuum Tube Socket, Octal
G-2484	Resistor-Capacitor Mounting Strip and Lugs	P-2590	Fuse Holder
G-2489	Resistor-Capacitor Mounting Strip and Lugs	P-2592	Fuse, 1 Amp., Cartridge Fusetron
G-2491	Resistor-Capacitor Mounting Strip and Lugs	P-2618	Terminal Strip Stud (2)
G-2492	Cable Form	P-2621	Neon Indicator Light Socket Fastening Nut
H-2653	Chassis Stop Stud Fastening Screw (2)	P-2622	Neon Indicator Light Socket Lockwasher
H-2715	Mounting-Terminal Strip-Filter-Transformer-Capacitor Fastening Screw (51)	P-2635	Fuse Holder Rubber Washer
H-2716	Terminal Strip Fastening Screw (2)	P-2636	Fuse Holder Fastening Nut
H-2717	Selenium Rectifier Fastening Screw	P-2744	Terminal Lug
H-2747	Relay Fastening Screw (2)	P-2802	Resistor, 300 Ohms, 1 Watt (3)
H-3051	License-Nameplate Fastening Screw (8)	P-2814	Neon Indicator Light Socket Fibre Washer
H-3243	Potentiometer-Switch Fastening Nut (20)	P-2878	Terminal Strip, Lug
H-3244	Power Switch Fastening Nut (2)	P-2936	Selenium Rectifier Fibre Washer
H-3247	Pilot Light Lens Fastening Nut	P-2999	Cable Clamp
H-3253	Choke-Filter-Transformer-Capacitor-Fastening Nut (50)	P-3415	Capacitor, 500 mf, 6 V
H-3255	Chassis Stop Screw Fastening Nut (2)	P-3417	Capacitor, .015 mf, 300 V (6)
H-3265	Power Transformer Fastening Nut (4)	P-3425	Vacuum Tube Socket, Min.—9 Pin (4)
H-3405	Relay Lockwasher (2)	P-3426	Vacuum Tube Shield, Min. (4)
H-3436	Chassis Stop Stud Lockwasher (2)	P-3438	Potentiometer, 1 Meg., 2 Watts (4)
H-3440	Potentiometer Lockwasher (9)	P-3522	Jack Insulated Tip (2)
H-3446	Power Switch Lockwasher	P-3524	Resistor, 15 K, 2 Watts (4)
H-3449	Power Transformer Lockwasher (4)	P-3690	Resistor, 220 Ohms, 1 Watt
H-3501	Tube Socket Fastening Eyelets (22)	P-3691	Resistor, 43 K, 1 Watt (3)
P-1016	Resistor, 150K, 1 Watt	P-3692	Resistor, 2400 Ohms, 1 Watt (5)
P-1075	Potentiometer, 2500 Ohms, 2 Watts (5)	P-3693	Resistor, 2.7 Ohms, 1 Watt (4)
P-1238	Chassis Stop Screw Lockwasher (2)	P-3694	Resistor, 10 Ohms, 1 Watt (4)
P-1278	Mounting-Terminal Strip-Filter-Transformer-Capacitor Lockwasher (62)	P-3695	Resistor, 390 Ohms, 1 Watt (6)
P-1280	Switch, 3 Pos.-4 Pos. Lockwasher (2)	P-3696	Resistor, 560 K, 1 Watt (3)
P-2038	Resistor, 5.1 Ohms, 1 Watt	P-3697	Resistor, 1.2 Meg., 1 Watt
P-2040	Resistor, 510 Ohms, 1 Watt	P-3698	Resistor, 82 Ohms, 1 Watt
P-2042	Resistor, 10 K, 1 Watt	P-3699	Resistor, 12 K, 2 Watts (3)
P-2045	Resistor, 100 K, 1 Watt	P-3702	Resistor, 4.3 Meg., 1 Watt
P-2046	Resistor, 470 K, 1 Watt (3)	P-3703	Resistor, 3.9 K, 2 Watts
P-2048	Resistor, 1 Meg., 1 Watt (11)	P-3704	Resistor, 20 Meg., 1 Watt
P-2051	Resistor, 1 K, 1 Watt	P-3707	Resistor, 2.2 Meg., 1 Watt
P-2058	Capacitor, .01 mf, 600 V	P-3708	Resistor, 180 K, 1 Watt (5)
P-2084	Capacitor, 40 mf/450 V, 40 mf/450 V, Electrolytic	P-3710	Resistor, 20 K, 1 Watt (6)
P-2089	Power Switch, D.P.S.T. Toggle	P-3712	Selenium Rectifier
P-2090	Pilot Light Socket	P-3713	Relay
P-2099	Capacitor, .1 mf, 400 V (6)	P-3714	Audio Transformer (5)
P-2130	Vacuum Tube 5Y3-GT	P-3715	Germanium Diode, IN-38-A (7)
P-2162	Chassis Stop Stud (2)	P-3716	Pilot Light Lens
P-2166	Chassis Stop Screw (2)	P-3717	Power Transformer
P-2176	Capacitor Mounting Plate	P-3719	Filter, Bandpass 30 Cycles
P-2183	3 Pos.-4 Pos. Switch Knob (2)	P-3720	Filter, Bandpass 35 Cycles
P-2237	Chassis Reinforcement Plate (2)	P-3721	Filter, Bandpass 40 Cycles
P-2257	Capacitor Mounting Plate	P-3722	Filter Choke, 10 H, 60 MA.
P-2391	License Plate	P-3723	Filter Choke, 20 H, 10 MA.
P-2425	Pilot Light 6-8 V	P-3725	Capacitor, .25 mf, 400 V (6)
P-2493	Resistor, 100 Ohms, 1 Watt (6)	P-3726	Capacitor, 1 mf, 400 V (2)
P-2557	Neon Indicator Light Socket	P-3727	Capacitor, .5 mf, 200 V
		P-3729	Capacitor, .02 mf, 400 V
		P-3730	Capacitor, 100 mf/25 V, 500 mf/25 V, Electrolytic
		P-3736	Switch, 4 Pole, 3 Pos.
		P-3737	Switch, S.P. 4 Pos.
		P-3740	Vacuum Tube, 12AV7
		P-3741	Vacuum Tube, 12AX7 (3)
		P-3742	Vacuum Tube, 6AU6 (6)
		P-3744	Relay Mounting Spacer (2)
		P-3745	Vacuum Tube Socket, Min.—7 Pin (6)
		P-3746	Vacuum Tube Shield, Min. (6)
		P-3747	Front Panel
		P-3748	Chassis
		P-3749	Nameplate
		P-3750	Meter

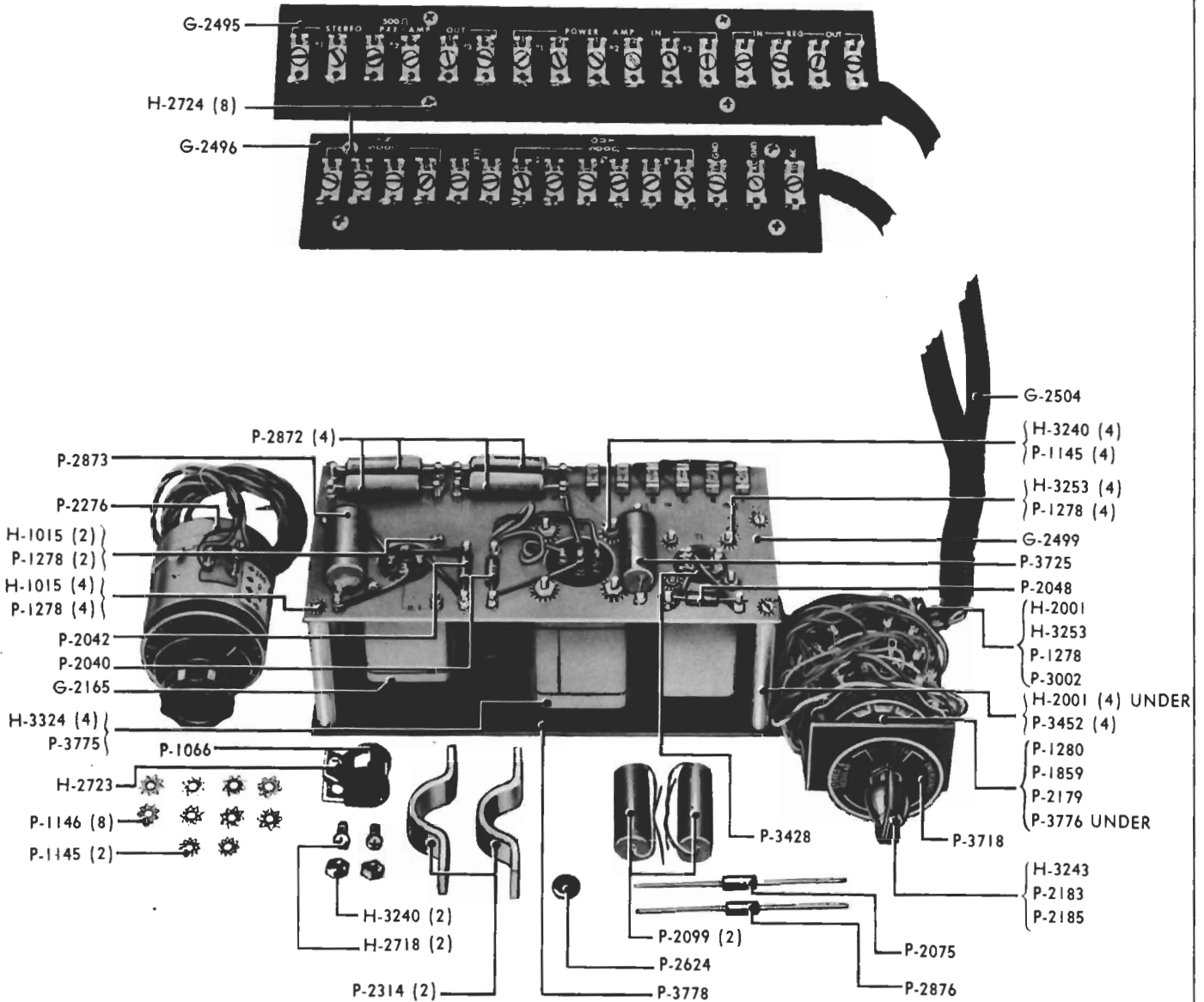

AM-1151 SYSTEM CABINET KIT

## AM-1151 SYSTEM CABINET KIT

G-2165	Dual Inductor
G-2495	Selector Switch Terminal Strip
G-2496	Control Unit Terminal Strip
G-2499	Resistor-Capacitor Mounting Strip and Lugs
G-2504	Cable Form
H-1015	Mounting Strip-Dual Inductor Fastening Screw (6)
H-2001	Mounting Strip Stud-Cable Clamp Fastening Screw (5)
H-2718	Selector Switch Mounting Plate Fastening Screw (2)
H-2723	Cabinet Cable Clamp Fastening Screw
H-2724	Selector Switch-Control Unit Terminal Strips Fastening Screw (8)
H-3240	HI-Pass Filter-Selector Switch Mounting Plate Fastening Nut (6)
H-3243	Selector Switch Dial Plate Fastening Nut
H-3253	Output Transformer-Cable Clamp Fastening Nut (5)
H-3324	HI-Pass Filter-Spacing Washer (4)
P-1066	Cabinet Cable Clamp
P-1145	HI-Pass Filter-Selector Switch Mounting Plate Lockwasher (6)
P-1146	Selector Switch-Control Unit Terminal Strips Lockwasher (8)
P-1278	Dual Inductor-Output Transformer-Mounting Plate-Cable Clamp Lockwasher (11)
P-1280	Selector Switch Lockwasher
P-1859	Selector Switch Fastening Nut
P-2040	Resistor, 510 Ohms, 1 Watt
P-2042	Resistor, 10 K, 1 Watt
P-2048	Resistor, 1 Meg., 1 Watt
*P-2075	Resistor, 470 Ohms, 1 Watt
*P-2099	Capacitor, 1 mf, 400 V (2)
P-2179	Selector Switch
P-2183	Selector Switch Knob
P-2185	Selector Switch Dial Plate Bushing
P-2276	Volume Control Dial Plate, Knob and Nuts
P-2314	Terminal Strip Clamp (2)
P-2624	Apparatus Blank
P-2872	Capacitor, .03 mf., 400 V (4)
P-2873	Capacitor, .15 mf., 400 V
*P-2876	Resistor, 120 Ohms, 1 Watt
P-3002	Cable Clamp
P-3428	Output Transformer
P-3452	Mounting Strip-Selector Switch Mounting Plate Stud (4)
P-3718	Selector Switch Dial Plate
P-3725	Capacitor, .25 MF, 400 V
P-3775	HI-Pass Filter
P-3776	Selector Switch Mounting Plate Insulator Strip
P-3778	Selector Switch Mounting Plate

\* Shipped separately with AM-1151 as alternate parts for Warming Network.

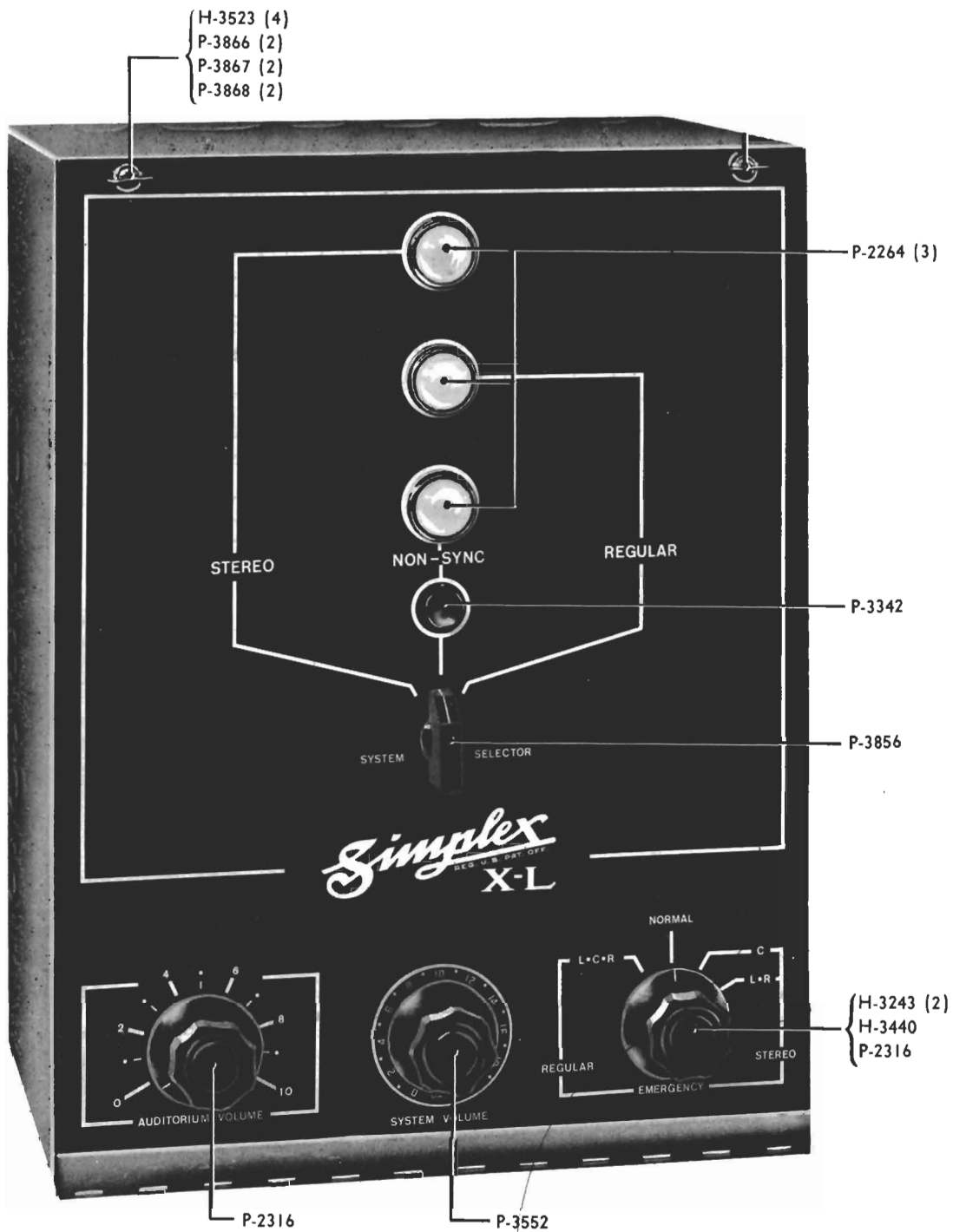

AM-1089 SYSTEM CONTROL CABINET

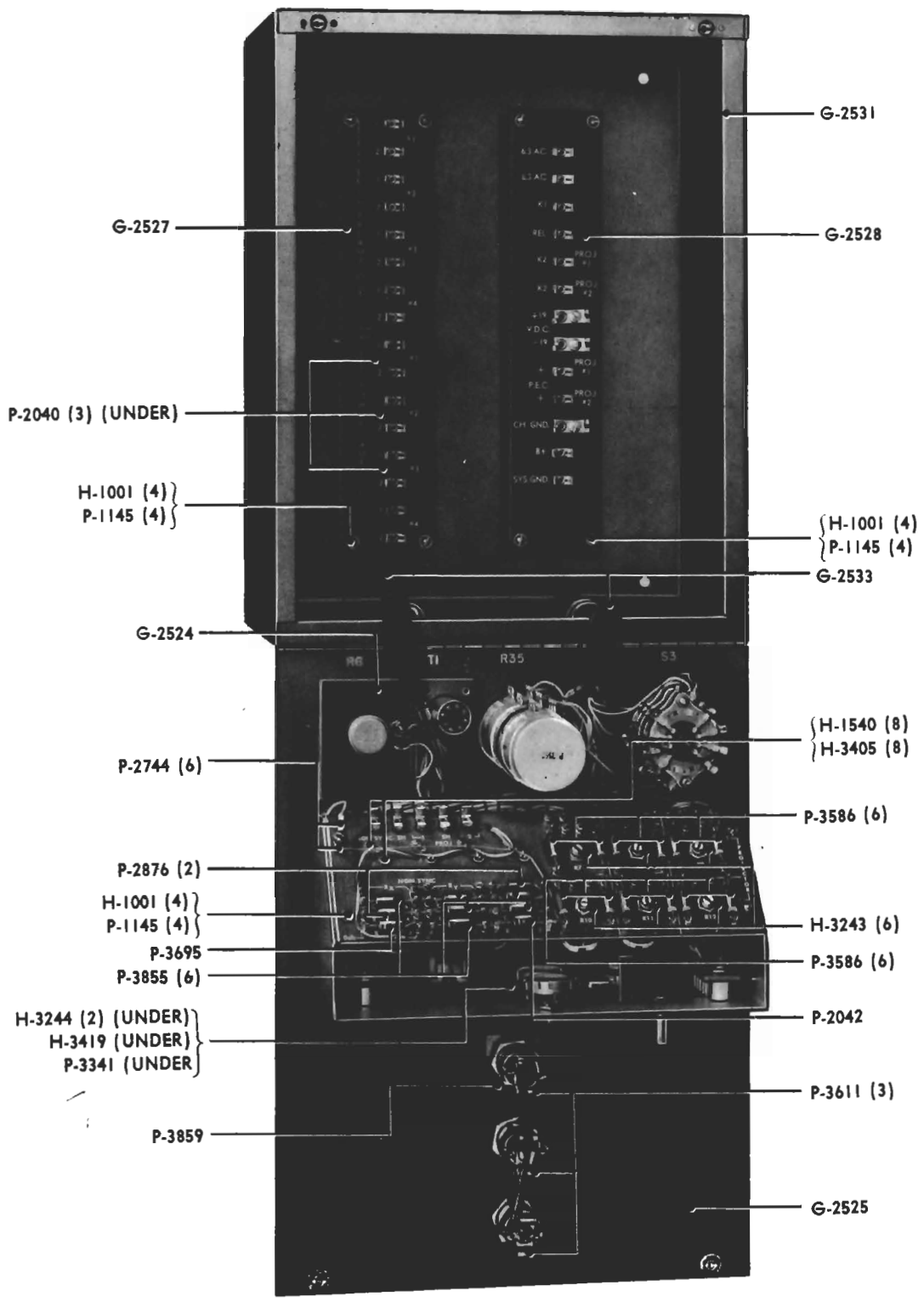

AM-1089 SYSTEM CONTROL CABINET

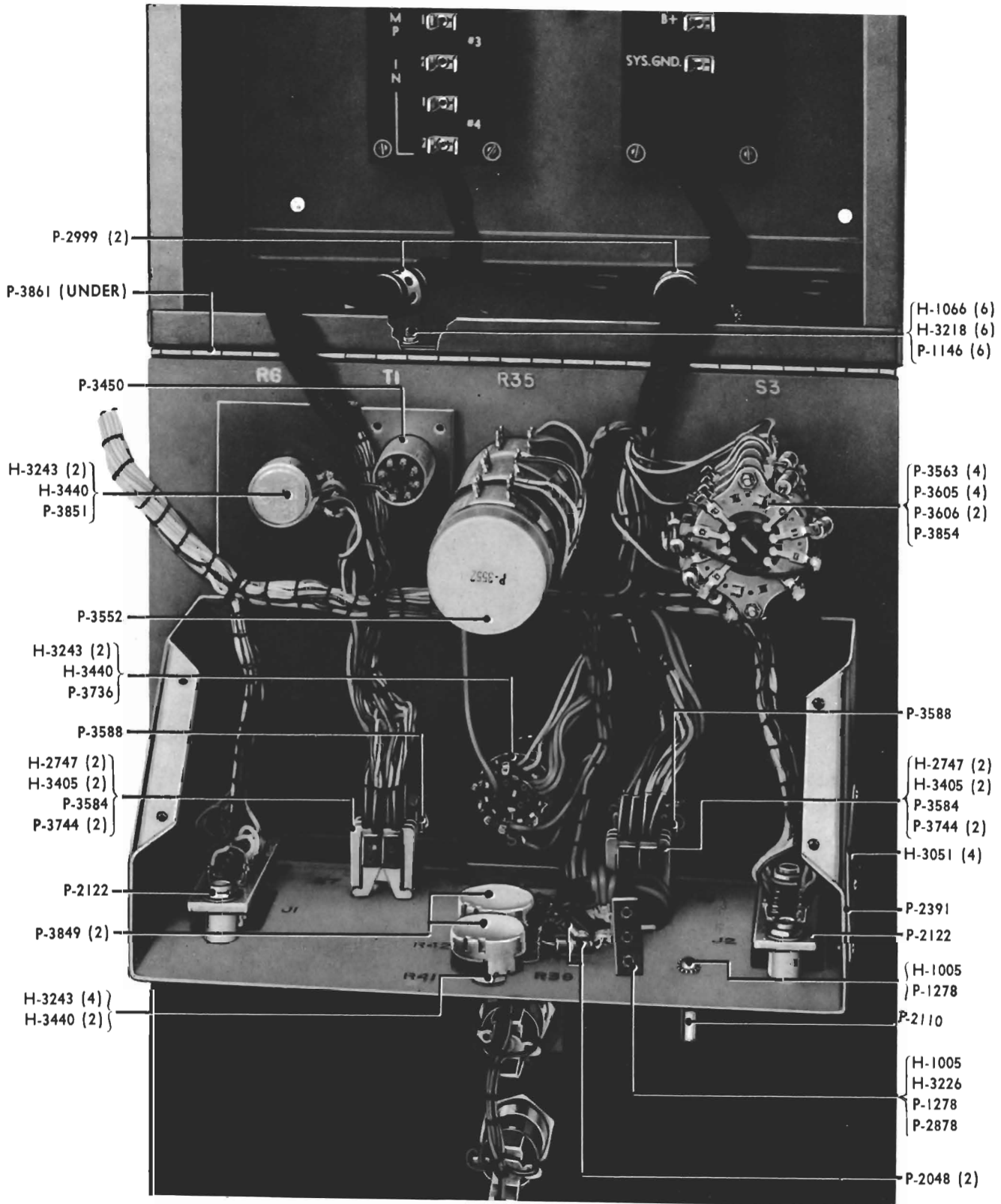

AM-1089 SYSTEM CONTROL CABINET

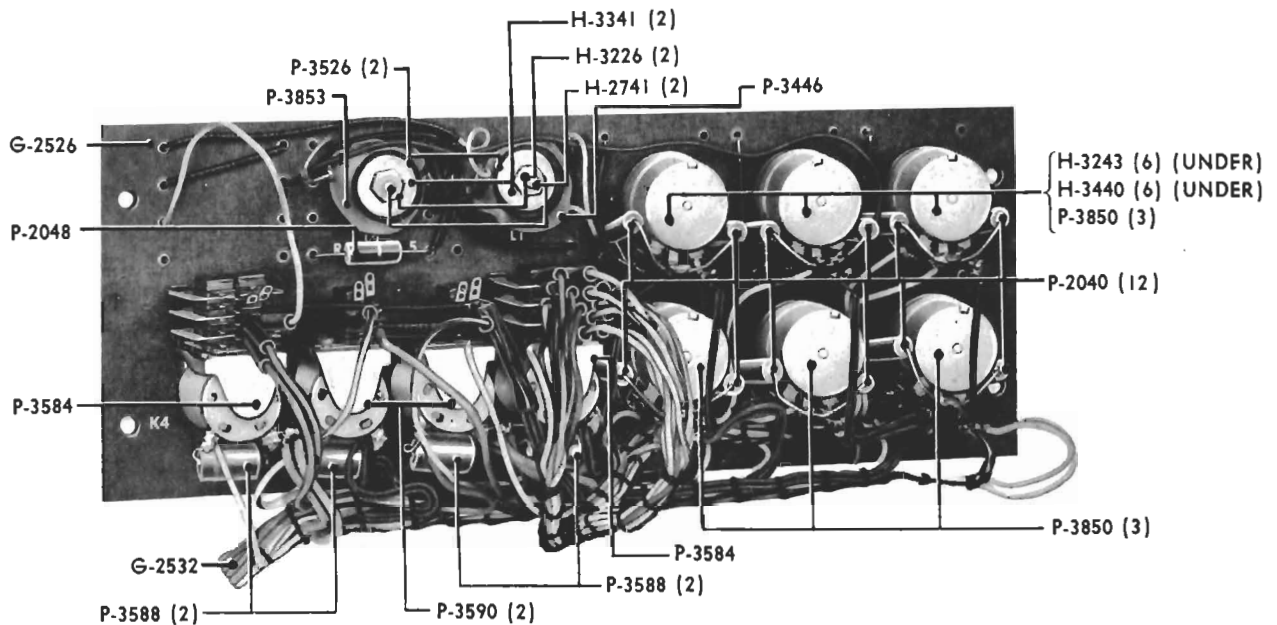

### AM-1089 SYSTEM CONTROL CABINET

G-2524	Transformer Mounting Plate	P-2122	Connector, Female (2)
G-2525	Front Panel	P-2264	Pilot Light Socket (3)
G-2526	Resistor-Capacitor Mounting Strip and Lugs	P-2316	Volume-Emergency Switch Knob (2)
G-2527	Amplifier Connection Terminal Strip	P-2391	License Plate
G-2528	Power Terminal Strip	P-2744	Terminal Lug (6)
G-2531	Cabinet	P-2876	Resistor, 120 Ohms, 1 Watt (2)
G-2532	Mounting Strip Cable Form	P-2878	Terminal Strip, Lug
G-2533	Power-Amplifier Connection Terminal Strip Cable Form	P-2999	Cable Clamp (2)
H-1001	Terminal-Mounting Strip Fastening Screw (12)	P-3341	Pushbutton Switch (Includes P-3342)
H-1005	Terminal Strip, Lug-Stud Fastening Screw (2)	P-3342	Pushbutton Switch Knob
H-1066	Panel Hinge Fastening Screw (6)	P-3446	Inductor, 30MH
H-1540	Relay Fastening Screw (8)	P-3450	Transformer
H-2741	Inductor Fastening Screw (2)	P-3526	Inductor Retaining Washer, Fibre (2)
H-2747	Relay Fastening Screw (4)	P-3552	Volume Control, Dial Plate, Knob and Screws
H-3051	License Plate Fastening Screw (4)	P-3563	Resistor, 330 Ohm, 1 Watt (4)
H-3218	Panel Hinge Fastening Nut (6)	P-3584	Relay, 6 P.D.T: (4)
H-3226	Terminal Strip, Lug-Inductor Fastening Nut (3)	*P-3586	Capacitor .1MF, 200V (14)
H-3243	Potentiometer-Switch, 4 Position Fastening Nut (22)	*P-3587	Capacitor .15MF, 200V (13)
H-3244	Pushbutton Switch Fastening Nut (2)	P-3588	Capacitor .25MF, 200V (6)
H-3341	Inductor Retaining Washer, Metal (2)	P-3590	Relay, 3 P.D.T. (2)
H-3405	Relay Lockwasher (12)	P-3605	Resistor, 240 Ohms, 1 Watt (4)
H-3419	Pushbutton Switch Lockwasher	P-3606	Resistor, 680 Ohms, 1 Watt (2)
H-3440	Potentiometer-Switch Lockwasher (11)	P-3611	Pilot Light, 28V (3)
H-3523	Panel Lock Plate Rivet (4)	P-3695	Resistor, 390 Ohms, 1 Watt
P-1145	Terminal-Mounting Strip Lockwasher (12)	P-3736	System Selector Switch, 4 Pole, 3 Position
P-1146	Panel Hinge Fastening Nut Lockwasher (6)	P-3744	Relay Mounting Spacer (4)
P-1278	Terminal Strip, Lug-Stud Lockwasher (2)	P-3849	Potentiometer, 500K, 1/2 Watt (2)
P-2040	Resistor, 510 Ohms, 1 Watt (15)	P-3850	Potentiometer, Dual 1500/1500 Ohms (6)
P-2042	Resistor, 10K, 1 Watt	P-3851	Potentiometer, 500 Ohms, 2 Watt
P-2048	Resistor, 1 Meg., 1 Watt (3)	P-3853	Inductor, 10MH
*P-2075	Resistor, 470 Ohms, 1 Watt	P-3854	Emergency Selector Switch, 6 Pole, 4 Position
P-2110	Stud	P-3855	Capacitor, .03MF, 200V (6)
		P-3856	System Selector Switch Knob
		P-3859	Pushbutton Switch Mounting Bracket
		P-3861	Hinge Spacer Plate
		P-3866	Panel Lock Receptacle (2)
		P-3867	Panel Wing Lock (2)
		P-3868	Panel Lock Bushing Retaining Washer (2)

\* Shipped Separately With AM-1089 As Alternate Parts For Attenuating And Warping Networks.  
Only (2) P-3586 Are Included With This Separate Shipment.

# SECTION III



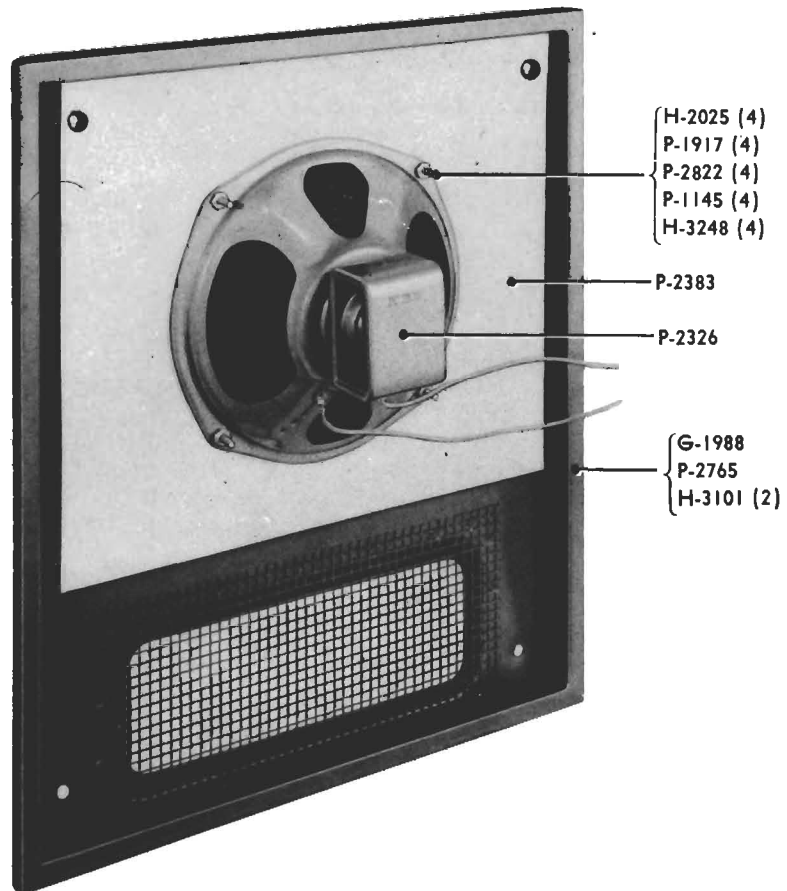
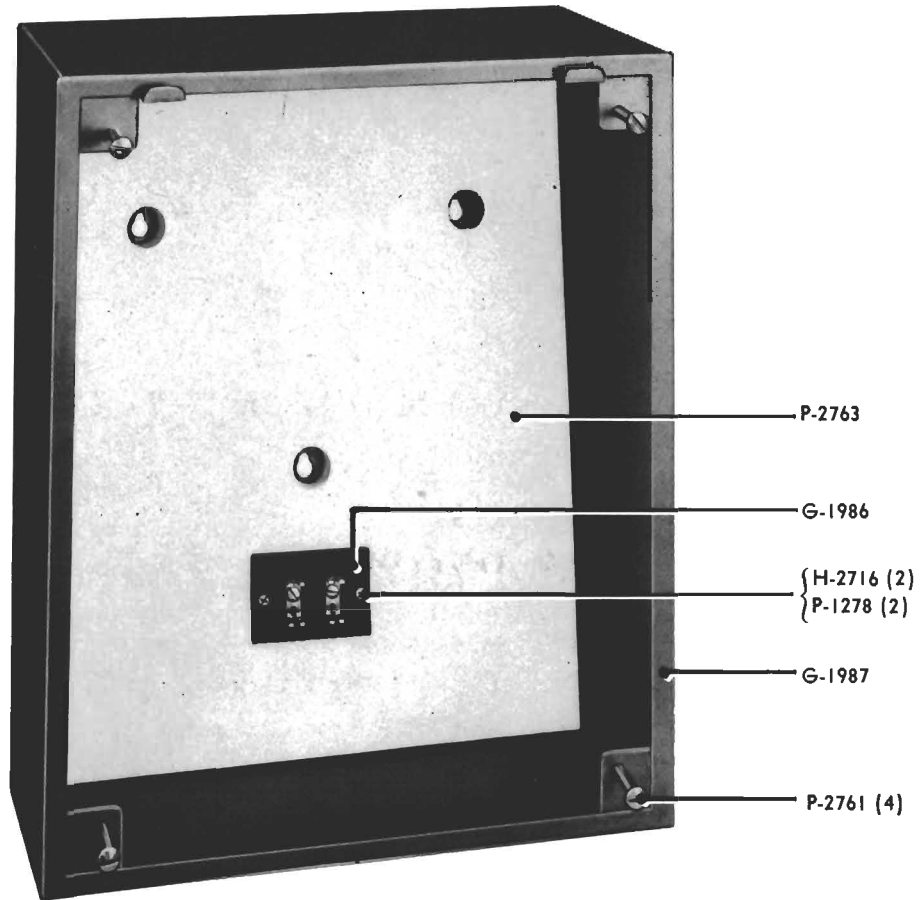

LU-142 MONITOR SPEAKER

## LU-142 MONITOR SPEAKER

G-1986 Terminal Strip  
G-1987 Cabinet  
G-1988 Cabinet Cover

H-2025 Speaker Fastening Screw (4)  
H-2716 Terminal Strip Fastening Screw (2)  
H-3101 Nameplate Fastening Screw (2)  
H-3248 Speaker Fastening Nut (4)

P-1145 Speaker Lockwasher (4)  
P-1278 Terminal Strip Lockwasher (2)  
P-1917 Speaker Washer (4)  
P-2326 Monitor Speaker  
P-2383 Cover Acoustic Baffle  
P-2761 Cover Fastening Screw (4)  
P-2763 Cabinet Acoustic Baffle  
P-2765 Nameplate  
P-2822 Speaker Spacer (4)

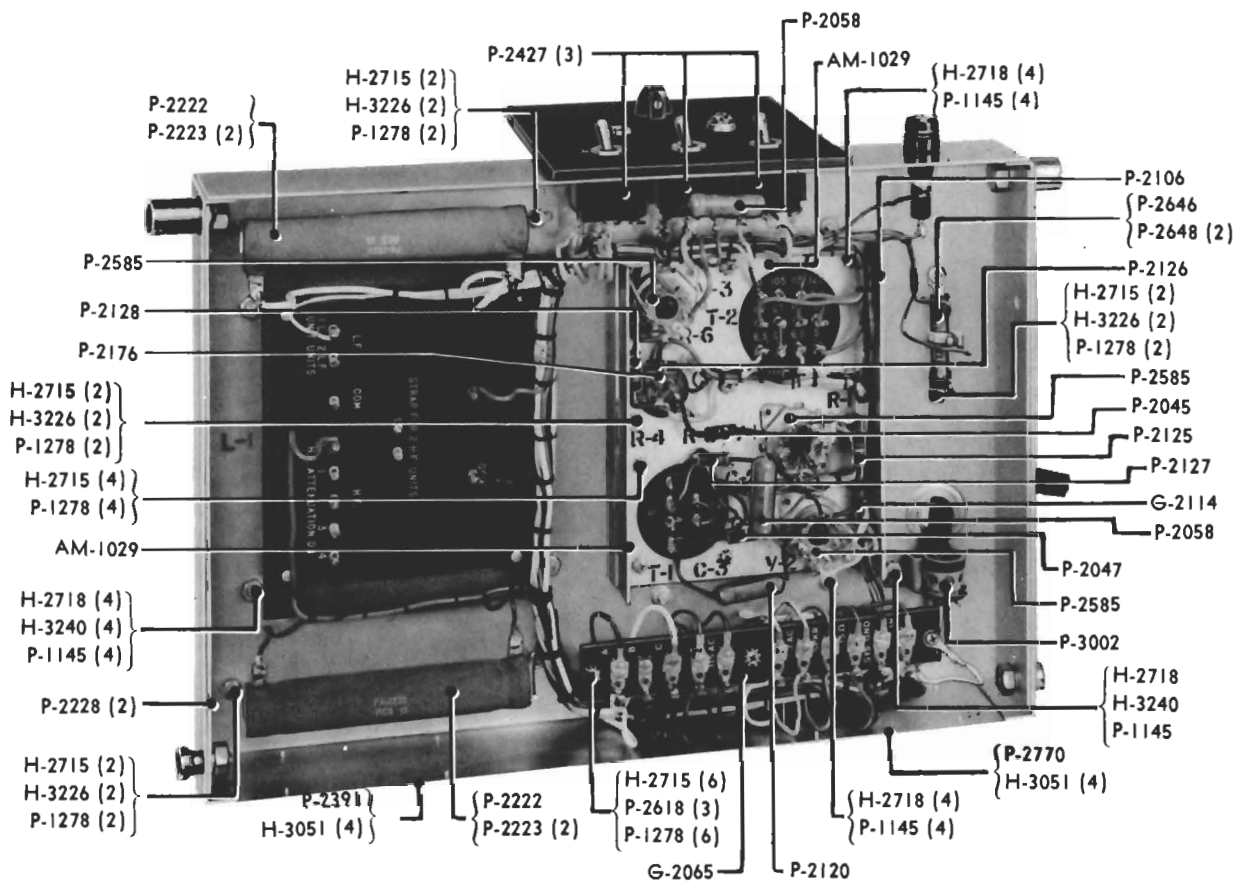
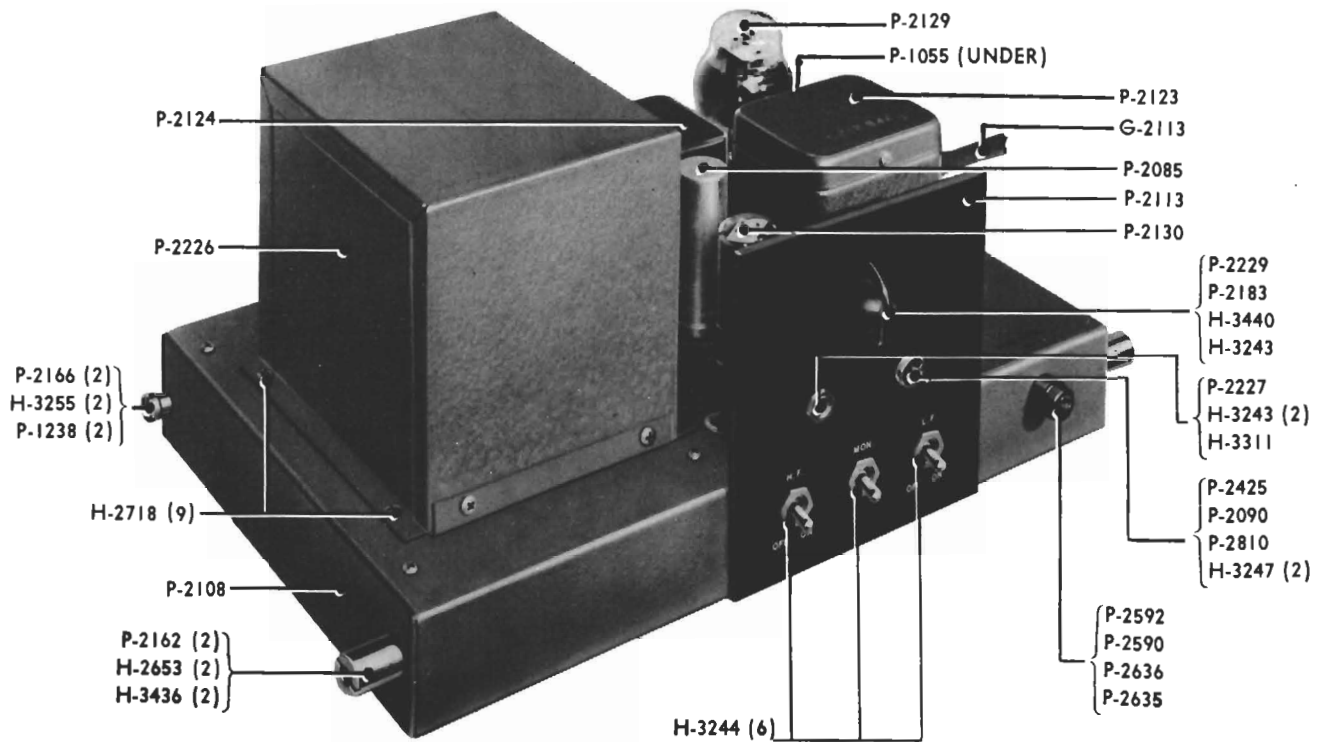

**LU-1103 LOUDSPEAKER NETWORK**  
 (Includes AM-1029 Monitor Amplifier)

## LU-1103 LOUDSPEAKER NETWORK

(Includes AM-1029 Monitor Amplifier)

G-2065	Terminal Strip	P-2090	Pilot Light Socket
G-2113	Cable Form	P-2108	Chassis
		P-2113	Front Panel
H-2653	Chassis Stop Stud Fastening Screw (2)	P-2162	Chassis Stop Stud (2)
H-2715	Resistor Mounting-Terminal Strip Fastening Screw (12)	P-2166	Chassis Stop Screw (2)
H-2718	Network-Amplifier Fastening Screw (9)	P-2183	Monitor Volume Control Knob
H-3051	Nameplate-License Plate Fastening Screw (8)	P-2222	Resistor, 15 ohms, 50 watt (2)
H-3226	Resistor Bracket Fastening Nut (6)	P-2223	Resistor Mounting Bracket (4)
H-3240	Network Fastening Nut (5)	P-2226	Dividing Network
H-3243	Test Jack-Monitor Volume Control Fastening Nut (3)	P-2227	Test Jack
H-3244	Switch Fastening Nut (6)	P-2228	Chassis Reinforcement Plate (2)
H-3247	Pilot Light Lens Fastening Nut (2)	P-2229	Monitor Volume Control
H-3255	Chassis Stop Screw Fastening Nut (2)	P-2391	License Plate
H-3311	Test Jack Washer	P-2425	Pilot Light, 6-8V
H-3436	Chassis Stop Stud Lockwasher (2)	P-2427	Monitor Amplifier Power-HF-LF Testing Switch, D.P.D.T. Toggle (3)
H-3440	Volume Control Lockwasher	P-2590	Fuse Holder
		P-2592	Fuse, 1 Amp. Cartridge Fusetron
P-1145	Network-Amplifier Lockwasher (9)	P-2618	Terminal Strip Mounting Stud (3)
P-1238	Chassis Stop Screw Lockwasher (2)	P-2635	Fuse Holder Rubber Washer
P-1278	Resistor-Terminal Strip Lockwasher (12)	P-2636	Fuse Holder Fastening Nut
P-2058	Capacitor, 0.01 mf, 600V	P-2646	Resistor, 100 ohms, 10 watt
		P-2648	Resistor Mounting Bracket (2)
		P-2770	Nameplate
		P-2810	Pilot Light Lens
		P-3002	Cable Clamp

## AM-1029 MONITOR AMPLIFIER

G-2114	Cable Form	P-2085	Capacitor, 20/25, 20/450, 20/450 Electrolytic
H-2715	Output Transformer-Capacitor Plate Fastening Screw (6)	P-2106	Chassis
H-2718	Power Transformer Fastening Screw (4)	P-2120	Capacitor, 0.001 mf, 600V
H-3226	Capacitor Plate Fastening Nut (2)	P-2123	Power Transformer
P-1055	Vacuum Tube, 6SL7-GT	P-2124	Output Transformer
P-1145	Power Transformer Lockwasher (4)	P-2125	Resistor, 1,500 ohms, 1 watt
P-1278	Output Transformer-Capacitor Plate Lockwasher (6)	P-2126	Resistor, 22,000 ohms, 1 watt
P-2045	Resistor, 0.1 Meg., 1 watt	P-2127	Resistor, 2,700 ohms, 1 watt
P-2047	Resistor, 0.51 Meg., 1 watt	P-2128	Resistor, 330 ohms, 2 watt
P-2058	Capacitor, 0.01 mf, 600V	P-2129	Vacuum Tube, 6L6-G
		P-2130	Vacuum Tube, 5Y3-GT
		P-2176	Capacitor Mounting Plate
		P-2585	Vacuum Tube Socket, Octal (3)

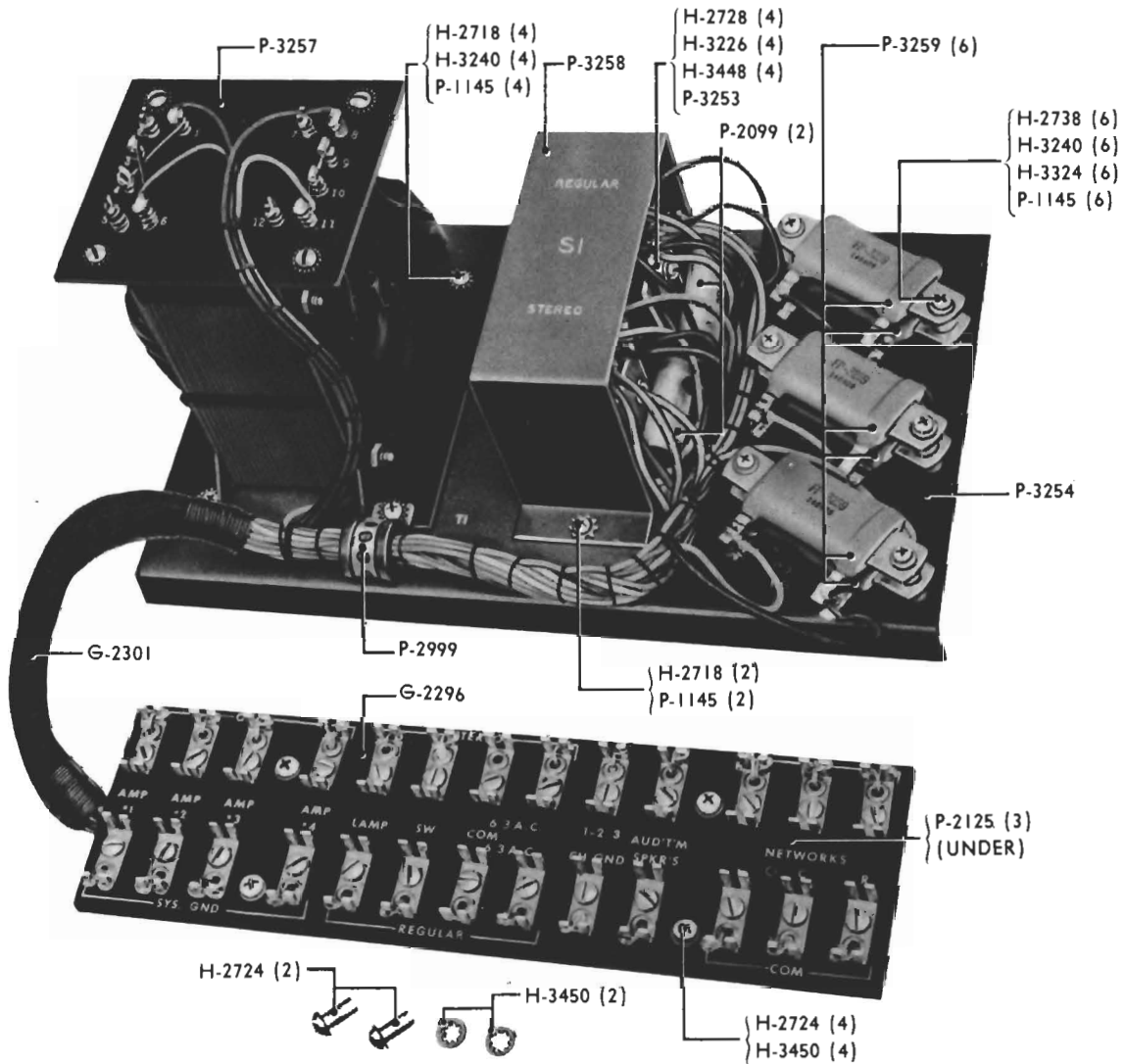

LU-1122 SPEAKER SWITCH KIT

## LU-1122 SPEAKER SWITCH KIT

G-2296	Terminal Strip
G-2301	Cable Form
H-2718	Transformer-Relay Cover-Cable Clamp Fastening Screw (6)
H-2724	Terminal Strip-Chassis Mounting Fastening Screw (6)
H-2728	Relay Fastening Screw (4)
H-2738	Resistor Fastening Screw (6)
H-3226	Relay Fastening Nut (4)
H-3240	Transformer-Resistor Fastening Nut (10)
H-3324	Resistor Plain Washer (6)
H-3448	Relay Lockwasher (4)
H-3450	Terminal Strip-Chassis Mounting Lockwasher (6)
P-1145	Transformer-Resistor-Relay Cover Lockwasher (12)
P-2099	Capacitor, .1 mf, 400 V (2)
P-2125	Resistor, 1,500 Ohms, 1 Watt (3)
P-2999	Cable Clamp
P-3253	Twin Relay
P-3254	Chassis
P-3257	Transformer
P-3258	Relay Cover
P-3259	Resistor, 15 Ohms, 40 Watt (6)

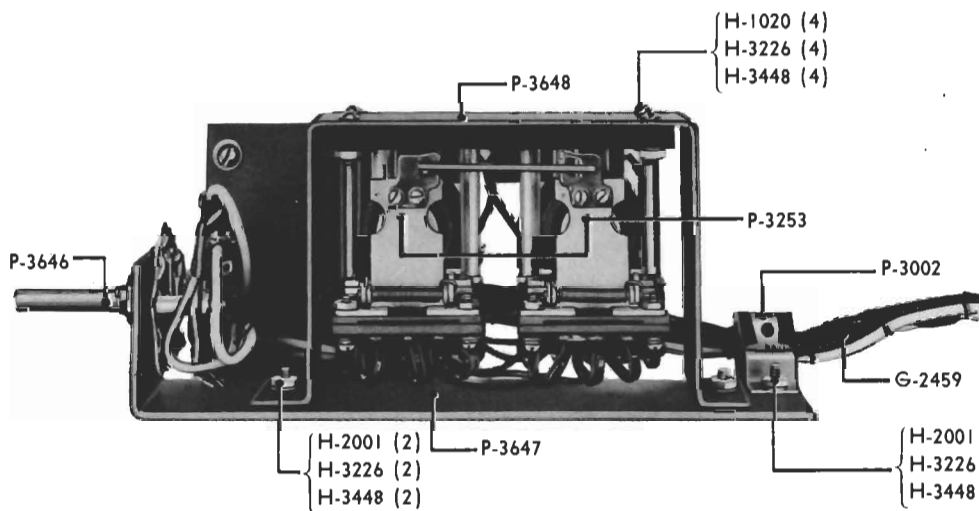
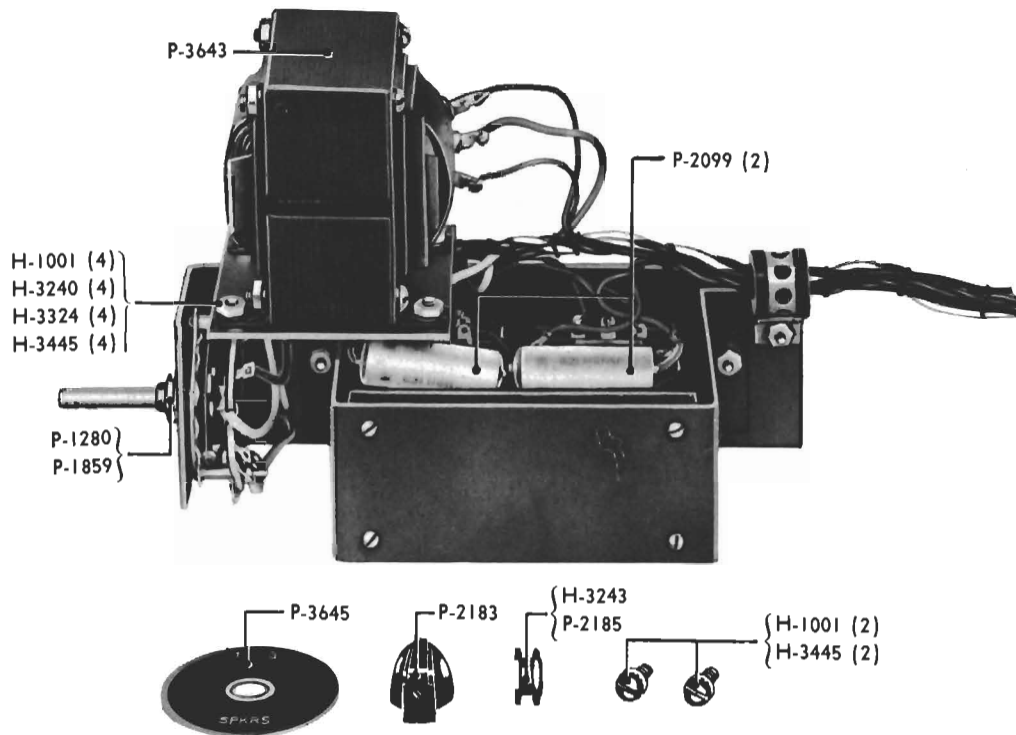

LU-1177 3 SPEAKER OPTICAL SWITCH KIT

## LU-1177 3 SPEAKER OPTICAL SWITCH UNIT

G-2459	Cable Form
H-1001	Chassis-Transformer Fastening Screw (6)
H-1020	Relay Fastening Screw (4)
H-2001	Relay Mounting Bracket-Cable Clamp Fastening Screw (3)
H-3226	Relay Mounting Bracket-Cable Clamp-Relay Fastening Nut (7)
H-3240	Transformer Fastening Nut (4)
H-3243	Switch Dial Plate Fastening Nut
H-3324	Transformer Retaining Washer (4)
H-3445	Chassis-Transformer Lockwasher (6)
H-3448	Relay Mounting Bracket-Cable Clamp Lockwasher (7)
P-1280	Switch Lockwasher
P-1859	Switch Fastening Nut
P-2099	Capacitor, .1 mf, 400 V (2)
P-2183	Switch Knob
P-2185	Switch Dial Plate Bushing
P-3002	Cable Clamp
P-3253	Relay
P-3643	Transformer, Matching
P-3645	Dial Plate
P-3646	Selector Switch
P-3647	Chassis
P-3648	Relay Mounting Bracket



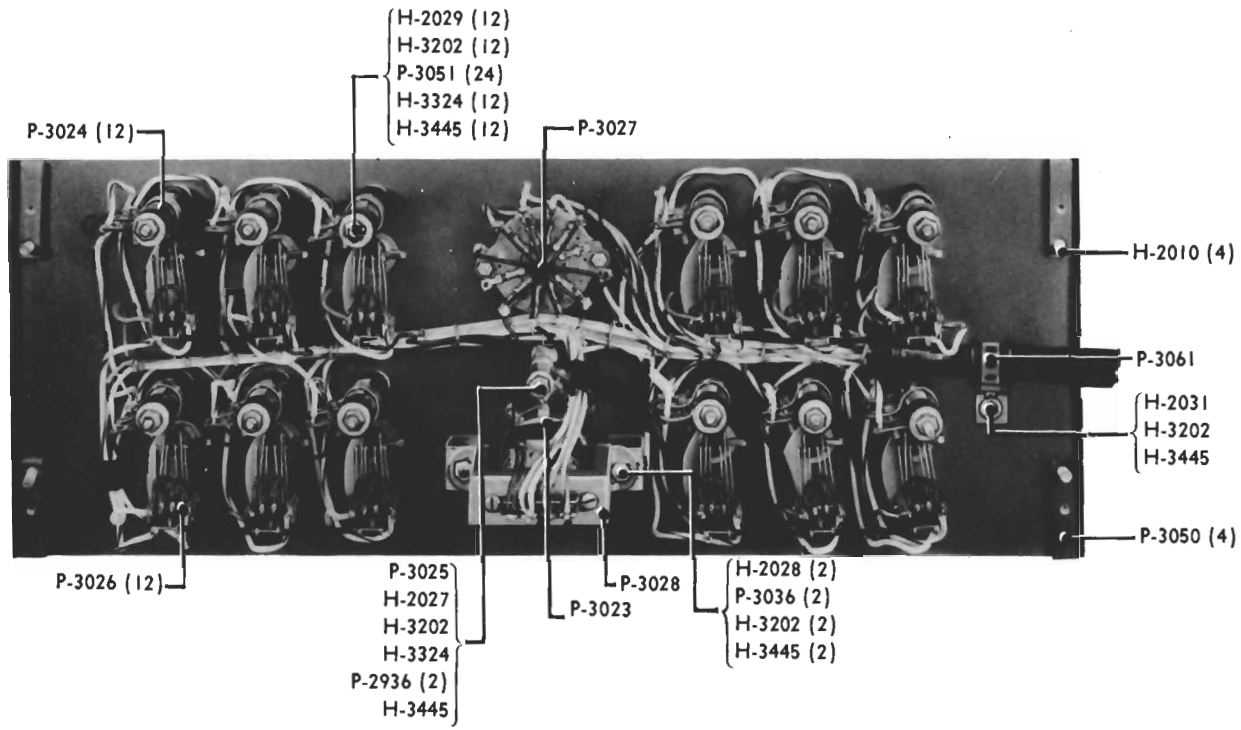
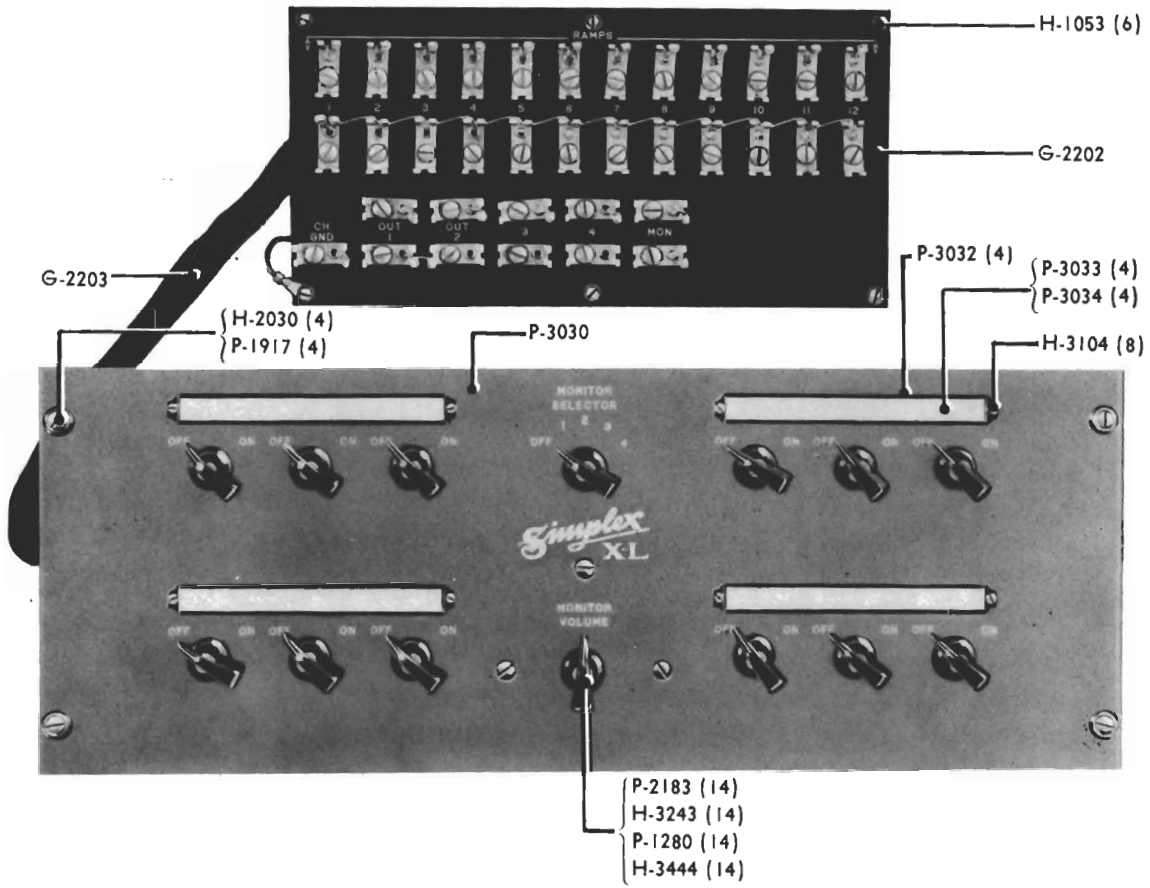

LU-3017 MONITOR SELECTOR-RAMP CONTROL PANEL

**LU-3017 MONITOR SELECTOR-RAMP CONTROL PANEL  
(DRIVE-IN EQUIPMENT ONLY)**

G-2202 Terminal Strip  
G-2203 Cable Form

H-1053 Terminal Strip Fastening Screw (6)  
H-2010 Spacer Fastening Screw (4)  
H-2027 Resistor Mounting Screw  
H-2028 Transformer Fastening Screw (2)  
H-2029 Resistor Mounting Screw (12)  
H-2030 Panel Fastening Screw (4)  
H-2031 Cable Clamp Fastening Screw  
H-3104 Designation Plate Fastening Screw (8)  
H-3202 Resistor-Transformer-Cable Clamp Fastening Nut (16)  
H-3243 Switch-Volume Control Fastening Nut (14)  
H-3324 Resistor Washer (13)  
H-3444 Switch-Volume Control Lockwasher (14)  
H-3445 Resistor-Transformer-Cable Clamp Lockwasher (16)

P-1280 Switch-Volume Control Lockwasher (14)  
P-1917 Panel Cup Washer (4)  
P-2183 Switch-Volume Control Knob (14)  
P-2936 Resistor Washer (2)  
P-3023 Monitor Volume Control  
P-3024 Resistor, 100 ohms, 25 watt, Adjustable (12)  
P-3025 Resistor, 200 ohms, 10 watt, Adjustable  
P-3026 Ramp Control Switch (12)  
P-3027 Monitor Selector Switch  
P-3028 Monitor Transformer  
P-3030 Panel  
P-3032 Designation Strip (4)  
P-3033 Designation Strip Card (4)  
P-3034 Designation Strip Celluloid (4)  
P-3036 Transformer Spacer (2)  
P-3050 Panel Spacer (4)  
P-3051 Resistor Washer (24)  
P-3061 Cable Clamp

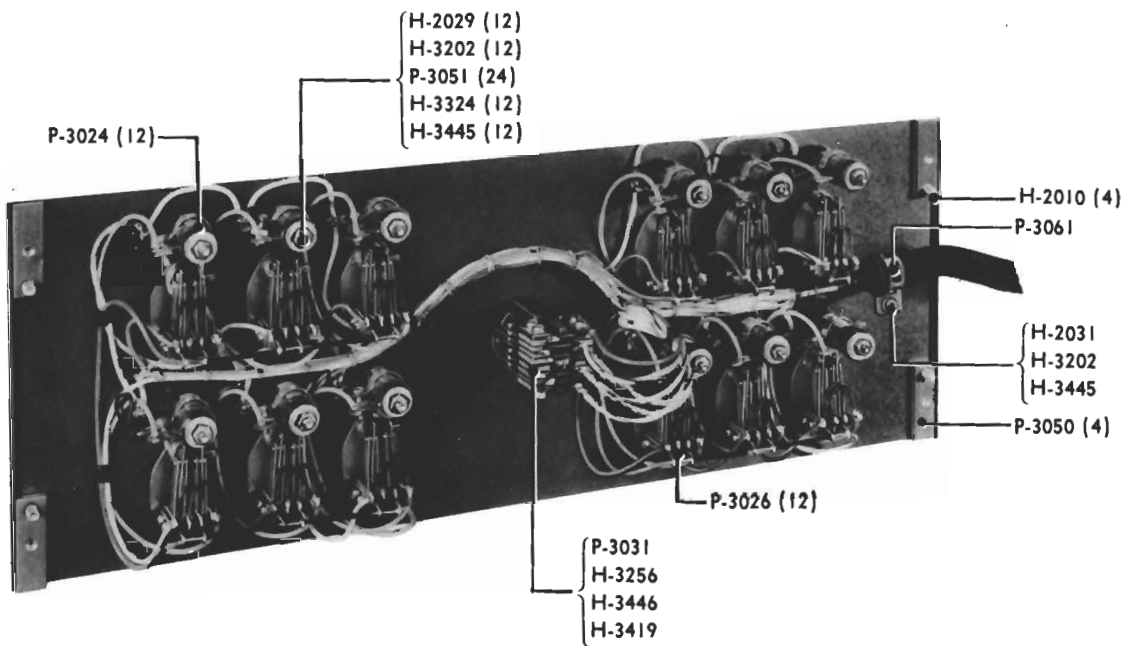
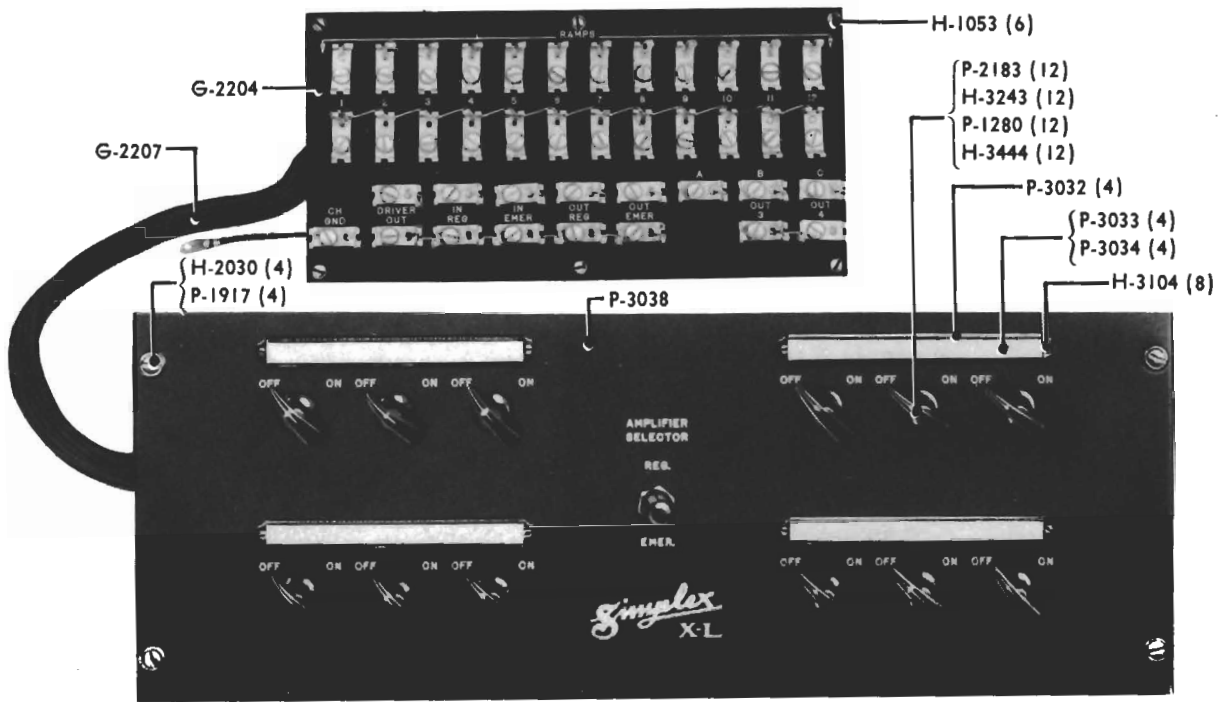

LU-3018 AMPLIFIER SELECTOR-RAMP CONTROL PANEL

**LU-3018 AMPLIFIER SELECTOR-RAMP  
CONTROL PANEL  
(DRIVE-IN EQUIPMENT ONLY)**

G-2204	Terminal Strip
G-2207	Cable Form
H-1053	Terminal Strip Fastening Screw (6)
H-2010	Spacer Fastening Screw (4)
H-2029	Resistor Mounting Screw (12)
H-2030	Panel Fastening Screw (4)
H-2031	Cable Clamp Fastening Screw
H-3104	Designation Plate Fastening Screw (8)
H-3202	Resistor-Cable Clamp Fastening Nut (13)
H-3243	Switch Fastening Nut (12)
H-3256	Switch Fastening Nut
H-3324	Resistor Washer (12)
H-3419	Selector Switch Washer
H-3444	Switch Lockwasher (12)
H-3445	Resistor-Cable Clamp Lockwasher (13)
H-3446	Selector Switch Lockwasher
P-1280	Switch Lockwasher (12)
P-1917	Panel Cup Washer (4)
P-2183	Ramp Control Switch Knob (12)
P-3024	Resistor, 100 ohms, 25 watt, Adjustable (12)
P-3026	Ramp Control Switch (12)
P-3031	Amplifier Selector Switch
P-3032	Designation Strip (4)
P-3033	Designation Strip Card (4)
P-3034	Designation Strip Celluloid (4)
P-3038	Panel
P-3050	Panel Spacer (4)
P-3051	Resistor Washer (24)
P-3061	Cable Clamp

# SECTION IV

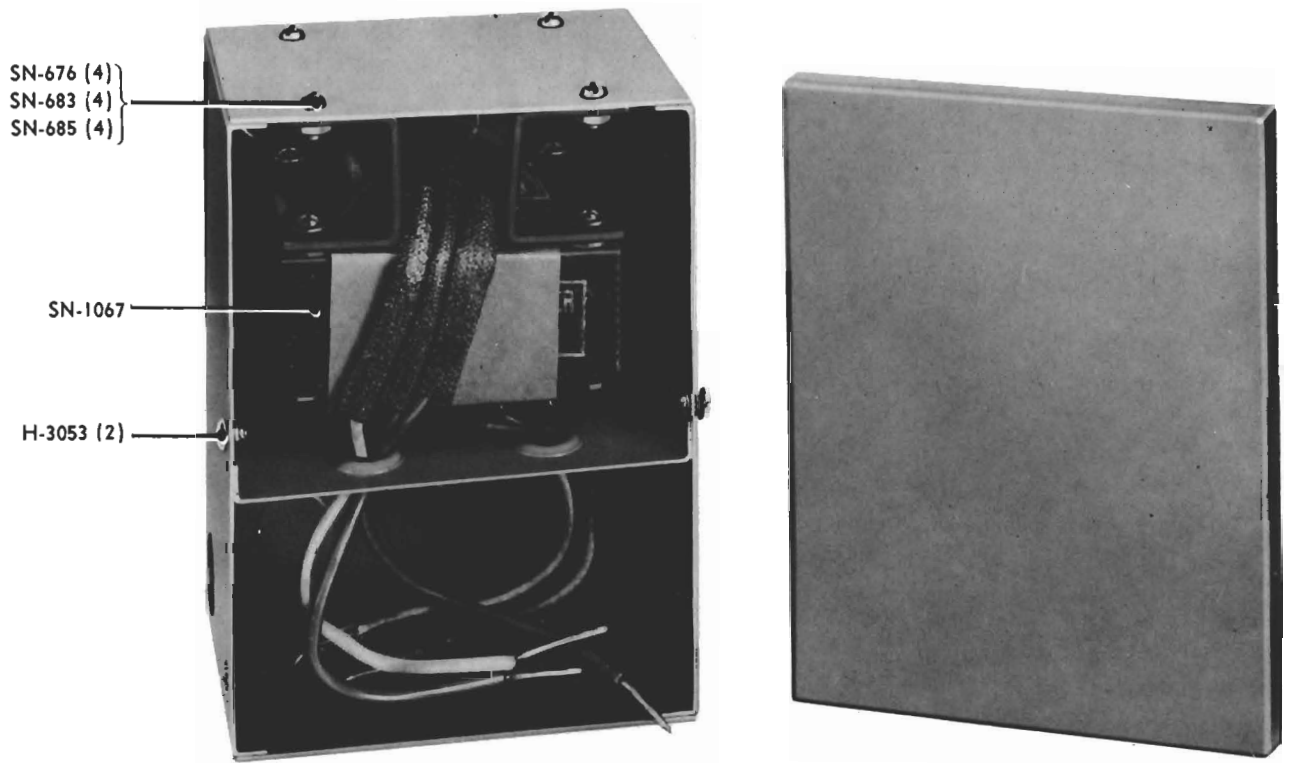

### PU-1005 POWER UNIT

H-3053 Cover Fastening Screw (2)

SN-676 Transformer Fastening Screw (4)

SN-683 Transformer Fastening Nut (4)

SN-685 Transformer Fastening Lockwasher (4)

SN-1067 Transformer

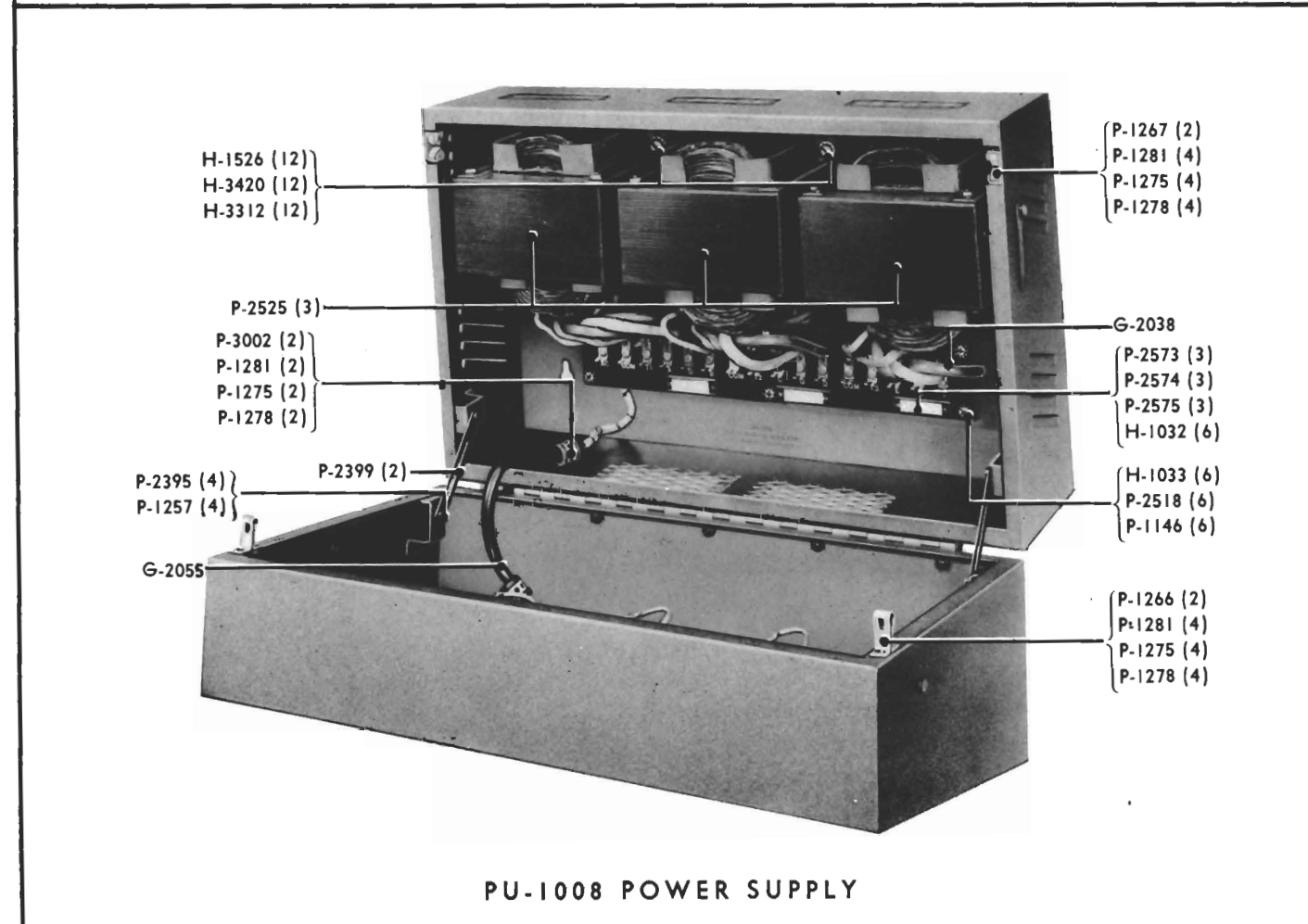

PU-1008 POWER SUPPLY

**PU-1008 POWER SUPPLY**  
(DRIVE-IN EQUIPMENT ONLY)

G-2037 Cabinet  
G-2038 Terminal Strip and Designation Strips  
G-2055 Cable Form

H-1032 Designation Plate Fastening Screw (12)  
H-1033 Terminal Strip Fastening Screw (6)  
H-1526 Transformer Fastening Screw (12)  
H-3304 Door Catch Link Spacer (2)  
H-3312 Transformer Fastening Washer (12)  
H-3419 AC Power Switch Lockwasher (3)  
H-3420 Transformer Lockwasher (12)  
H-3437 Fuseholder Lockwasher (3)

P-1146 Terminal Strip Lockwasher (6)  
P-1257 Door Stop Washer (4)  
P-1258 Door Catch Link Fastening Screw (4)  
P-1259 Door Catch Link (2)  
P-1266 Door Strike (2)  
P-1267 Door Catch (2)  
P-1275 Door Catch-Strike-Cable Clamp Fastening Nut (10)  
P-1276 Door Catch Link Fastening Nut (4)  
P-1278 Door Catch-Strike-Cable Clamp Lockwasher (10)  
P-1279 Door Catch Link Lockwasher (4)  
P-1281 Door Catch-Strike-Cable Clamp Fastening Screw (10)  
P-1734 AC Power Switch Fastening Nut (3)  
P-1932 AC Power Switch Fastening Nut (3)  
P-2395 Door Stop Fastening Screw (4)  
P-2399 Door Stop Link (2)  
P-2518 Terminal Strip Spacer (6)  
P-2525 Power Transformer (3)  
P-2557 Pilot Light Socket (3)  
P-2558 Pilot Light, 105-125V. Neon (3)  
P-2563 AC Power Switch, S.P.S.T., Toggle (3)  
P-2564 Fuseholder (3)  
P-2565 Fuse 10 Amp. Cartridge Fusetron (3)  
P-2573 Designation Strip (6)  
P-2574 Designation Strip Card (6)  
P-2575 Designation Strip Celluloid (6)  
P-2619 Fuseholder Rubber Washer (3)  
P-2620 Fuseholder Fastening Nut (3)  
P-2621 Pilot Light Socket Fastening Nut (3)  
P-2622 Pilot Light Socket Lockwasher (3)  
P-2814 Pilot Light Socket Fibre Washer (3)  
P-3002 Cable Clamp (2)



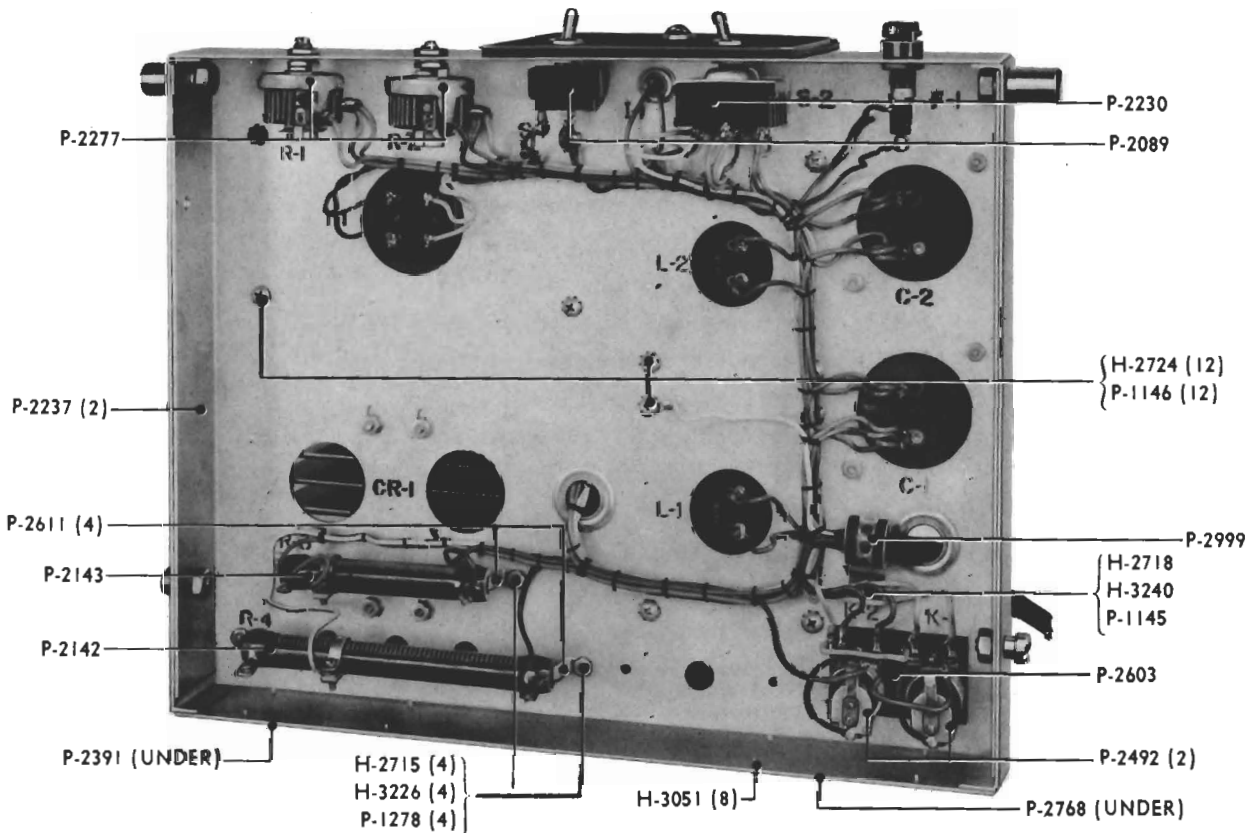
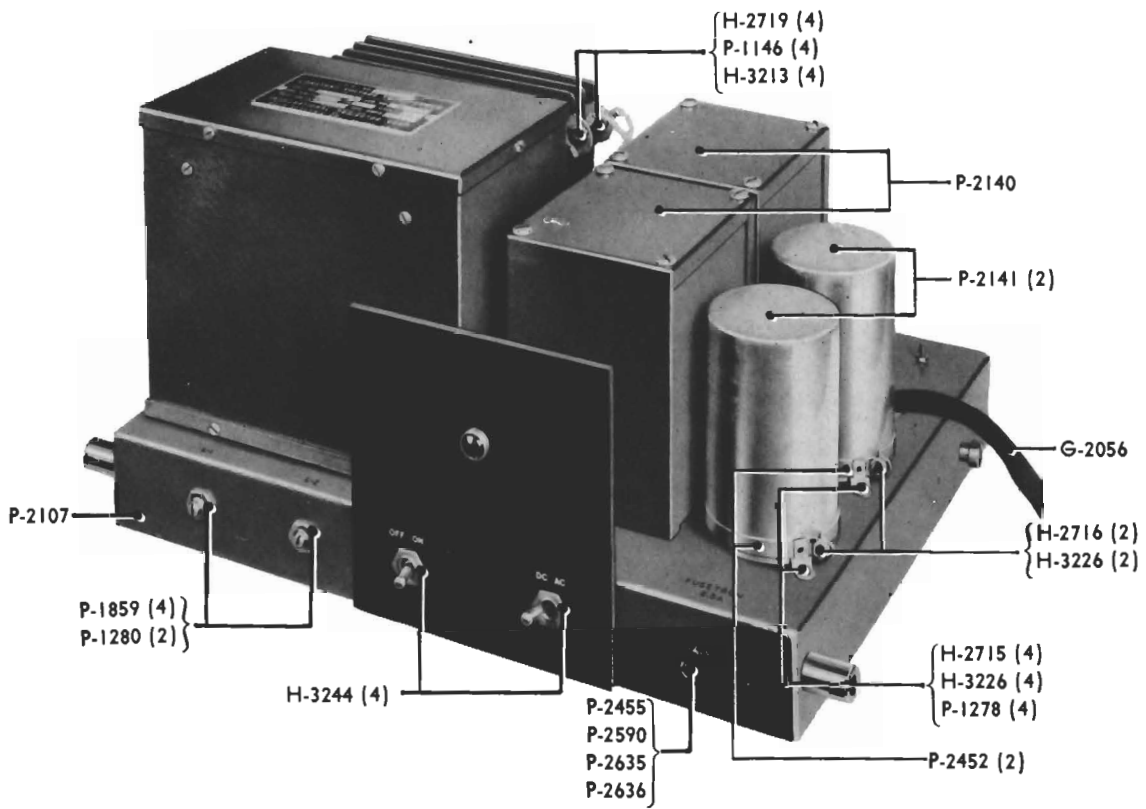

PU-1009 POWER UNIT (60 cycles)  
 PU-1010 POWER UNIT (50 cycles)

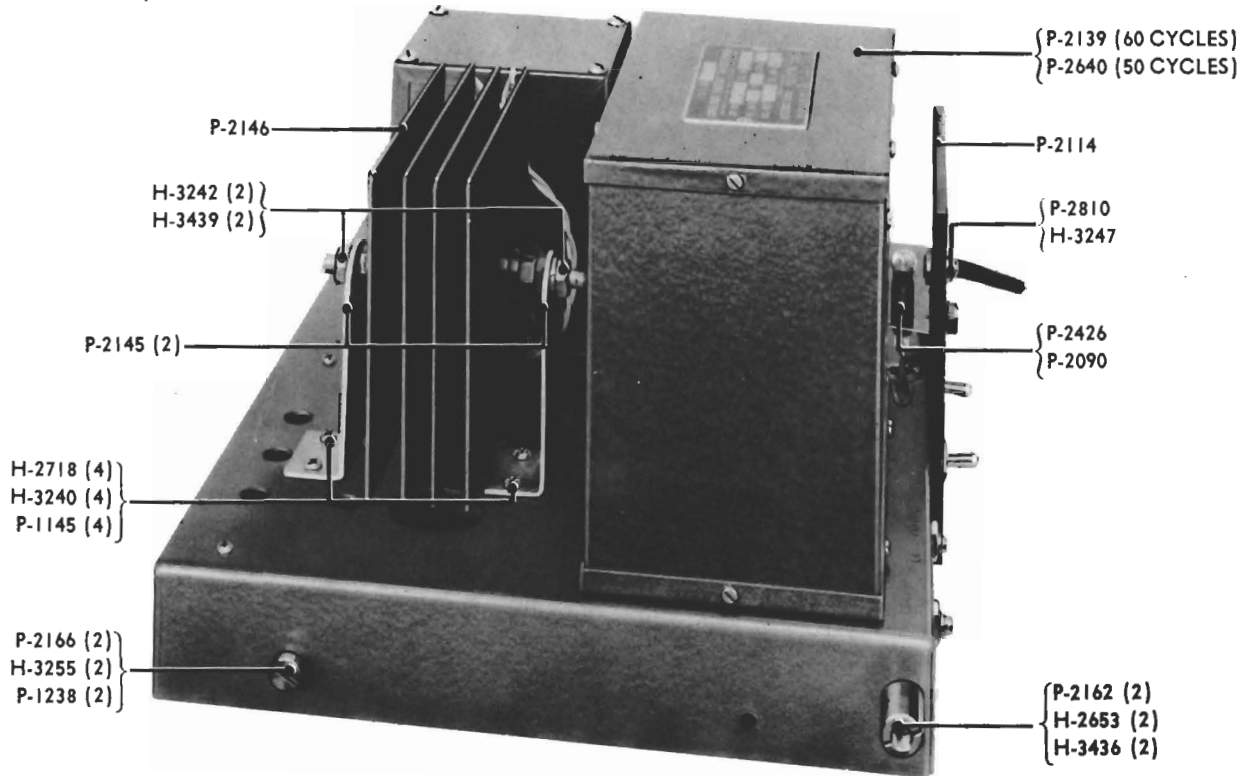

**PU-1009 POWER UNIT (60 cycles)**  
**PU-1010 POWER UNIT (50 cycles)**

G-2056	Cable Form	P-1278	Capacitor-Resistor Mounting Lockwasher (8)
H-2653	Chassis Stop Stud Fastening Screw (2)	P-1280	Rheostat Lockwasher (2)
H-2715	Capacitor-Resistor Mounting Fastening Screw (8)	P-1859	Rheostat Fastening Nut (4)
H-2716	Capacitor Mounting Ring Clamping Screw (2)	P-2089	Power Switch, D.P.S.T. Toggle
H-2718	Cable Clamp-Rectifier Bracket Fastening Screw (5)	P-2090	Pilot Light Socket
H-2719	Rectifier Terminal Screw (4)	P-2107	Chassis
H-2724	Transformer-Reactor Mounting Screw (12)	P-2114	Front Panel
H-3051	Nameplate-License Plate Mounting Screw (8)	P-2139	Power Transformer (60 cycles)
H-3213	Rectifier Terminal Screw Fastening Nut (4)	P-2140	Reactor (2)
H-3226	Capacitor-Resistor Mounting Fastening Nut (10)	P-2141	Capacitor, 6000 mf, 25V Electrolytic (2)
H-3240	Cable Clamp-Rectifier Bracket Fastening Nut (5)	P-2142	Resistor, 1 ohm, 75 watt, Adjustable
H-3242	Rectifier Fastening Nut (2)	P-2143	Resistor, 3 ohms, 50 watt, Adjustable
H-3244	Power-AC-DC Switch Fastening Nut (4)	P-2145	Rectifier Mounting Bracket (2)
H-3247	Pilot Light Lens Fastening Nut	P-2146	Selenium Rectifier
H-3255	Chassis Stop Screw Fastening Nut (2)	P-2162	Chassis Stop Stud (2)
H-3436	Chassis Stop Stud Lockwasher (2)	P-2166	Chassis Stop Screw (2)
H-3439	Rectifier Lockwasher (2)	P-2230	AC-DC Switch, 3 P.D.T. Toggle
P-1145	Cable Clamp-Rectifier Bracket Lockwasher (5)	P-2237	Chassis Reinforcement Plate (2)
P-1146	Transformer-Reactor-Rectifier Terminal Screw Lockwasher (16)	P-2277	Rheostat, 0.5 ohms, 25 watts (2)
P-1238	Chassis Stop Screw Lockwasher (2)	P-2391	License Plate
		P-2426	Pilot Light, 12V
		P-2452	Capacitor Mounting Ring (2)
		P-2455	Fuse, 2.5 Amp. Cartridge Fusetron
		P-2492	Relay (2)
		P-2590	Fuseholder
		P-2603	Relay Insulating Plate
		P-2611	Resistor Mounting Bracket (4)
		P-2635	Fuse Holder Rubber Washer
		P-2636	Fuse Holder Fastening Nut
		P-2640	Power Transformer (50 cycles)
		P-2768	Nameplate
		P-2810	Pilot Light Lens
		P-2999	Cable Clamp

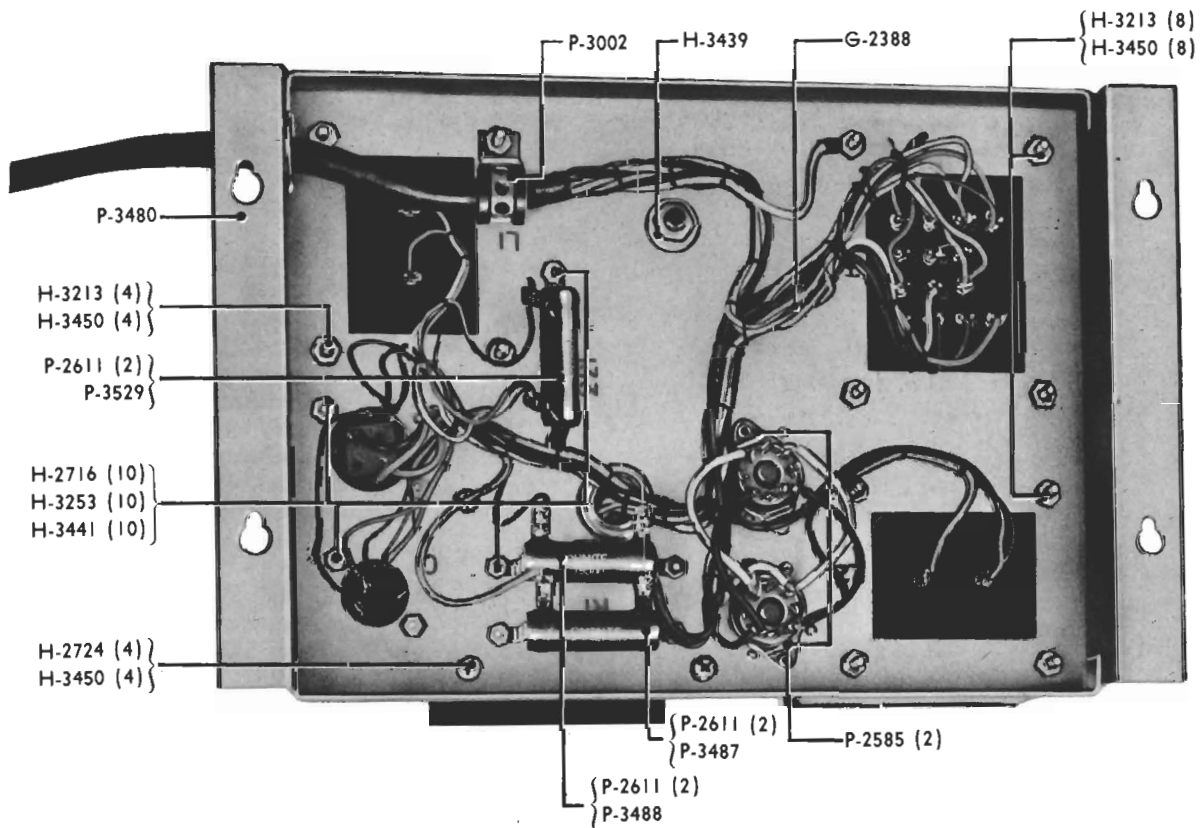
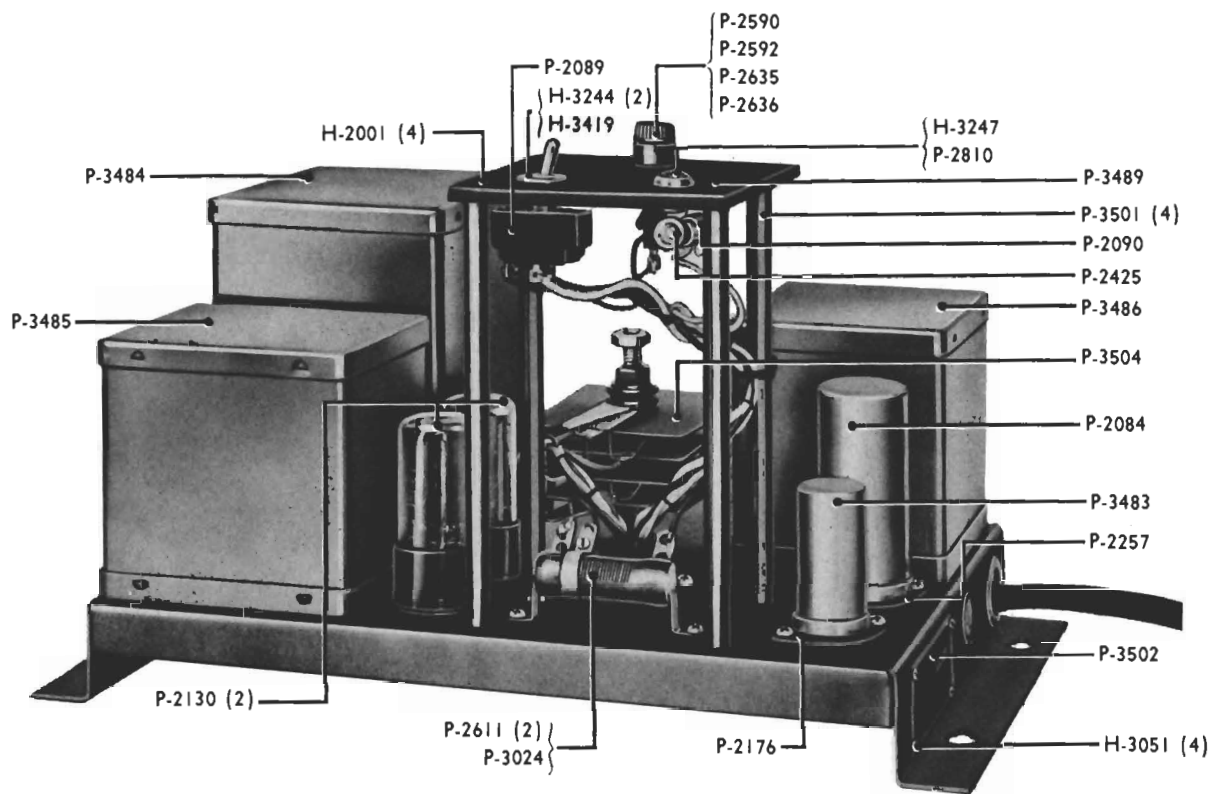

PU-1011 PRE-AMPLIFIER POWER SUPPLY

## PU-1011 PRE-AMPLIFIER POWER SUPPLY

G-2388	Cable Form
H-2001	Front Panel Fastening Screw (4)
H-2716	Resistor Mounting Bracket-Capacitor Mounting Plate Fastening Screw (10)
H-2724	Front Panel Mounting Stud Fastening Screw (4)
H-3051	Nameplate Fastening Screw (4)
H-3213	Transformer-Reactor Fastening Nut (12)
H-3244	Switch Fastening Nut (2)
H-3247	Pilot Light Lens Fastening Nut
H-3253	Capacitor Mounting Plate-Resistor Fastening Nut (10)
H-3419	Switch Lockwasher
H-3439	Selenium Rectifier Lockwasher
H-3441	Capacitor Mounting Plate-Resistor Lockwasher (10)
H-3450	Transformer-Reactor-Front Panel Mounting Stud Lockwasher (16)
P-2084	Capacitor, 40 mf/450 V, 40 mf/450 V
P-2089	Power Switch
P-2090	Pilot Light Socket
P-2130	Vacuum Tube 5Y3GT (2)
P-2176	Capacitor Mounting Plate
P-2257	Capacitor Mounting Plate
P-2425	Pilot Light, 6-8 V
P-2585	Vacuum Tube Socket, Octal (2)
P-2590	Fuse Holder
P-2592	Fuse, 1 Amp., Cartridge Fusetron
P-2611	Resistor Mounting Bracket (8)
P-2635	Fuse Holder Rubber Washer
P-2636	Fuse Holder Fastening Nut
P-2810	Pilot Light Lens
P-3002	Cable Clamp
P-3024	Resistor, 100 Ohms, 25 Watt, Adjustable
P-3480	Chassis
P-3483	Capacitor, 500 mf, 25 V
P-3484	Power Transformer
P-3485	Reactor, Filter 15 Henries
P-3486	Reactor, Filter 0.1 Henry
P-3487	Resistor, 750 Ohms, 25 Watt
P-3488	Resistor, 15 K, 25 Watt
P-3489	Front Panel
P-3501	Panel Mounting Stud (4)
P-3502	Nameplate
P-3504	Selenium Rectifier
P-3529	Resistor, 50 Ohms, 25 Watt

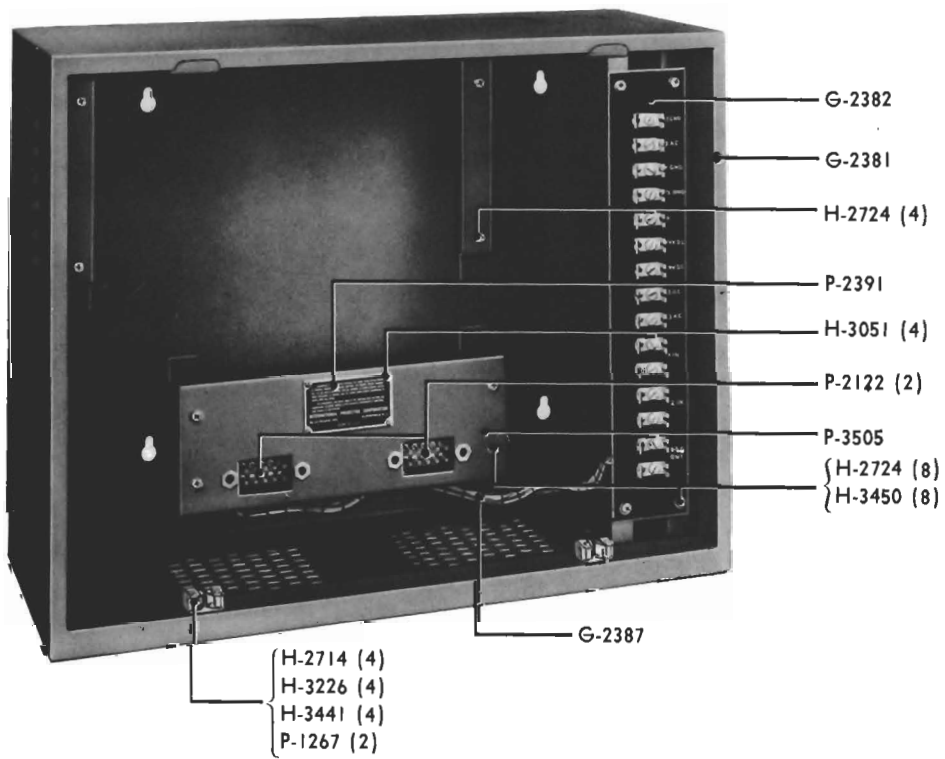
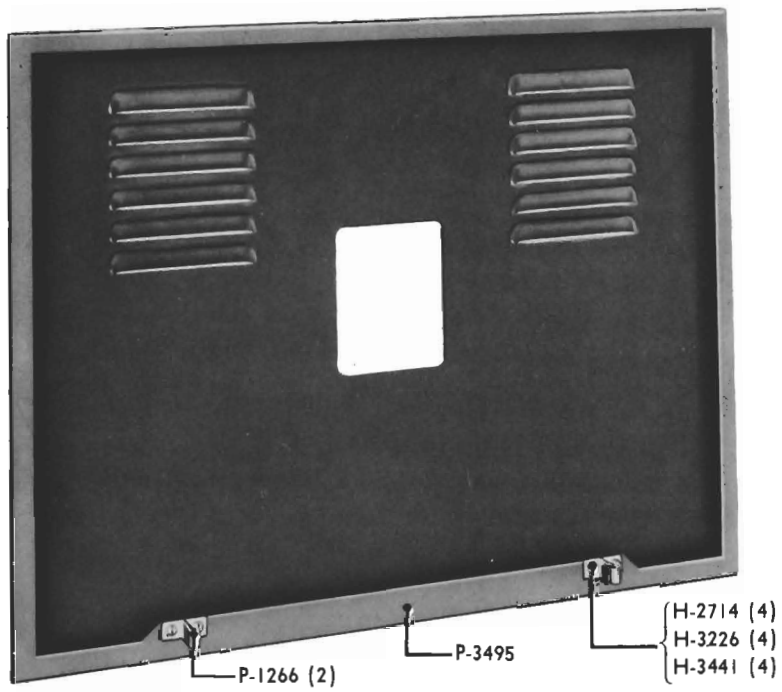

PU-1012 POWER SUPPLY

**PU-1012 POWER SUPPLY CABINET**  
**PU-1014 POWER SUPPLY CABINET**

- |          |   |          |  |
|----------|---|----------|--|
| G-2381   | Cabinet (Includes P-1266(2), P-1267(2), P-3495, H-2714(8), H-3226(8), H-3441(8))                                    | **H-3324 | Resistor Washer (3)  |
| *G-2382  | Terminal Strip  | H-3441   | Door Catch-Strike Lockwasher (8)<br>(Included with G-2381)                                       |
| *G-2387  | Cable Form  | **H-3445 | Resistor Lockwasher (3)  |
| **G-2561 | Terminal Strip  | H-3450   | Female Connector Mounting Panel Lockwasher (4) on PU-1012 only—<br>Terminal Strip Lockwasher (4) |
| **H-1054 | Resistor Mounting Screw (3)   | P-1266   | Door Strike (2) (Included with G-2381)   |
| H-2714   | Door Catch-Strike Fastening Screw (8)<br>(Included with G-2381)   | P-1267   | Door Catch (2) (Included with G-2381)  |
| H-2724   | Female Connector Mounting Panel Fastening Screw (4) on PU-1012 only—Terminal Strip—Power Supply Fastening Screw (8) | *P-2122  | Panel Connector, Female (2)  |
| H-3051   | License Plate Fastening Screw (4)   | *P-2391  | License Plate  |
| **H-3202 | Resistor Mounting Screw Fastening Nut (3)   | **P-3051 | Resistor Washer (6)  |
| H-3226   | Door Catch-Strike Fastening Nut (8)<br>(Included with G-2381)   | **P-3488 | Resistor, 15K, 25 Watt (3)   |
|          |   | P-3495   | Cabinet Cover (Included with G-2381)   |
|          |   | *P-3505  | Female Connector Mounting Panel  |
- \* PU-1012 Only  
\*\* PU-1014 Only

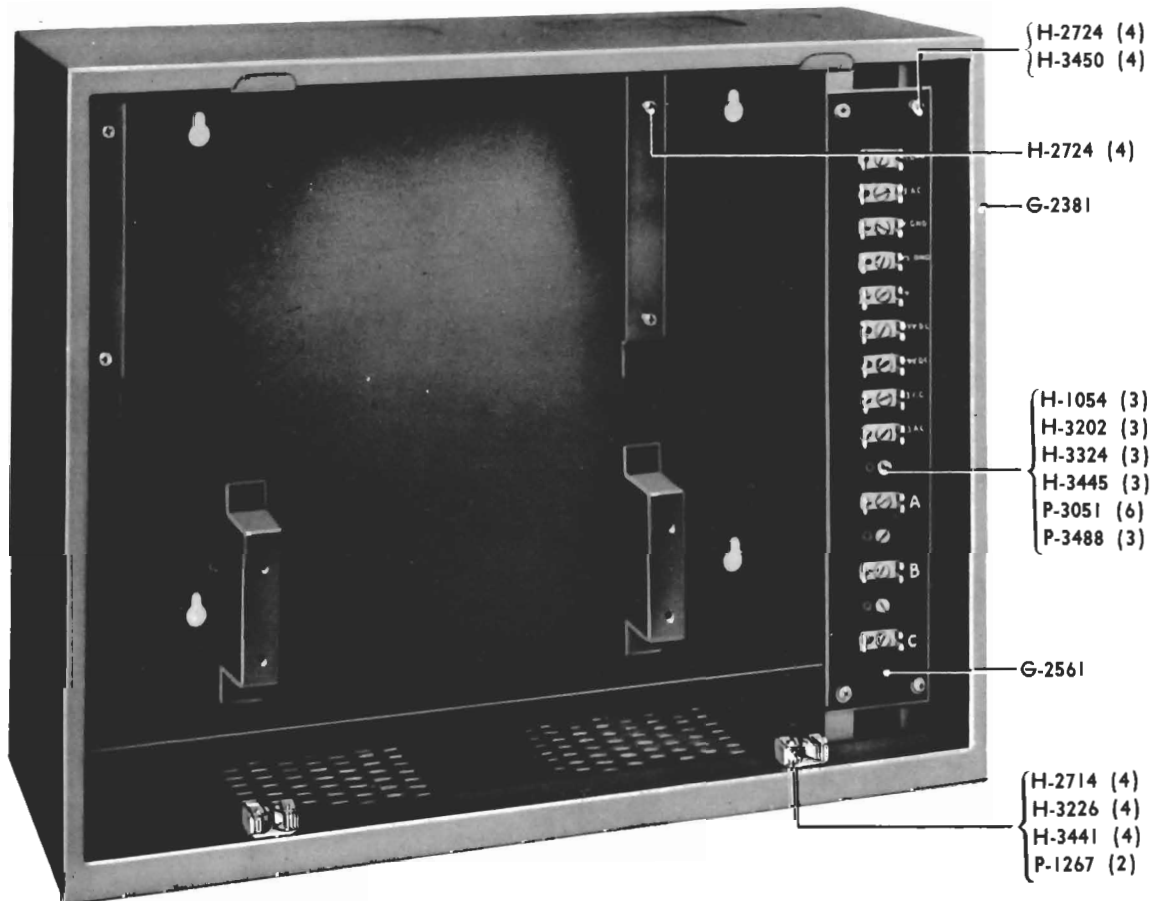

**PU-1014 POWER SUPPLY CABINET**  
**(COVER FOR CABINETS ON PAGE 4-8)**

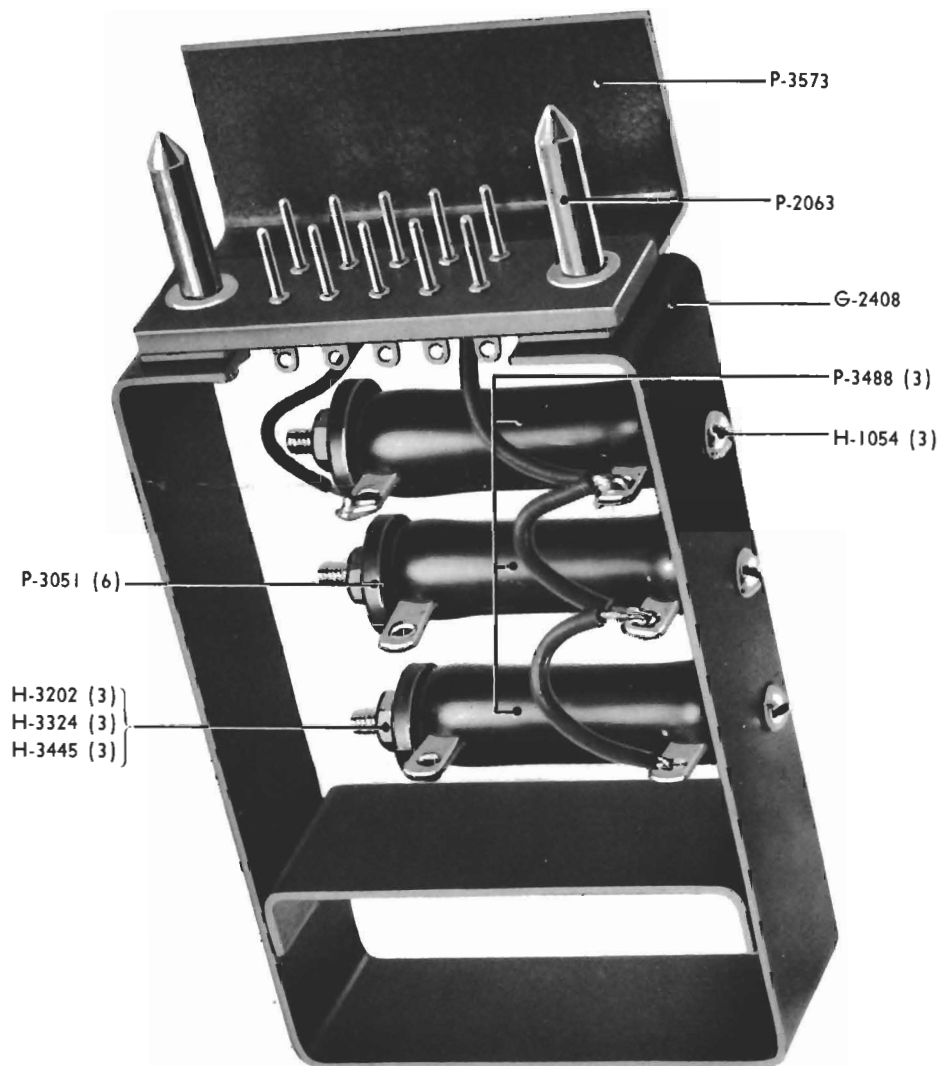

## PU-1013 POWER SUPPLY DUMMY LOAD

G-2408	Chassis
H-1054	Resistor Mounting Screw (3)
H-3202	Resistor Mounting Screw Fastening Nut (3)
H-3324	Resistor Washer (3)
H-3445	Resistor Lockwasher (3)
P-2063	Panel Connector, Male
P-3051	Resistor Washers (6)
P-3488	Resistor, 15K, 25 Watt (3)
P-3573	Panel Connector Mounting and Chassis Tie Bracket

# SECTION V



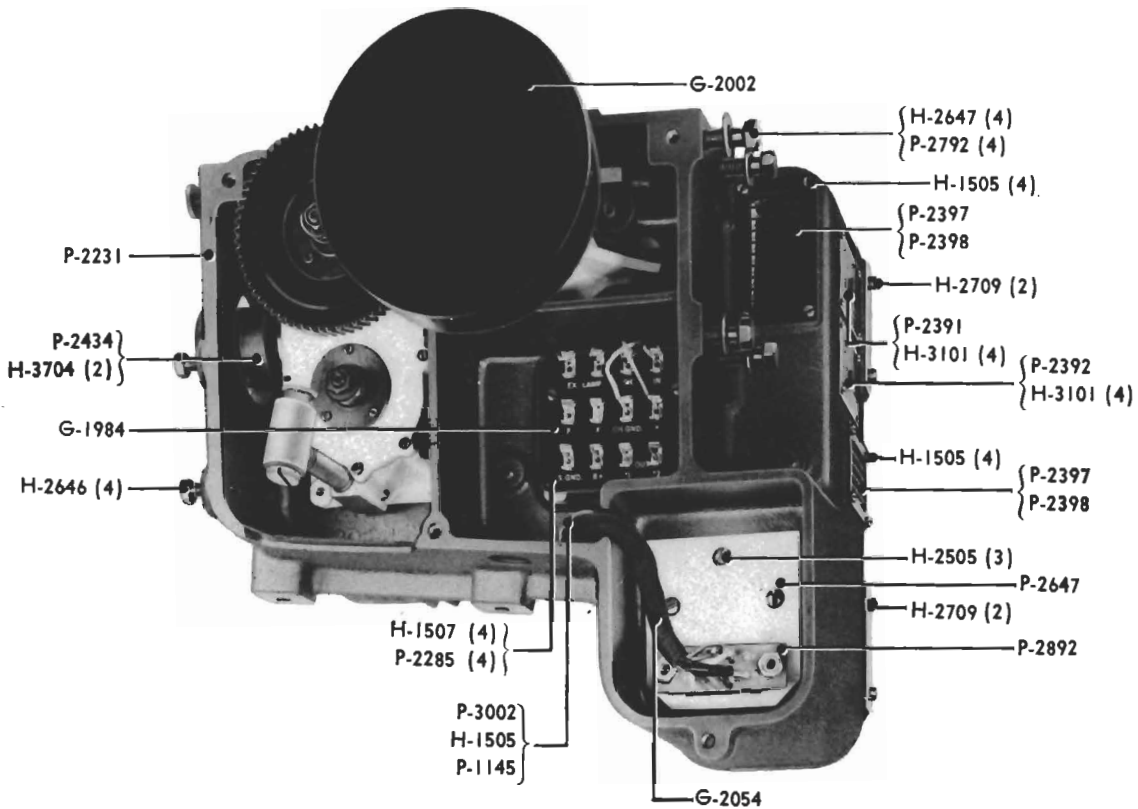
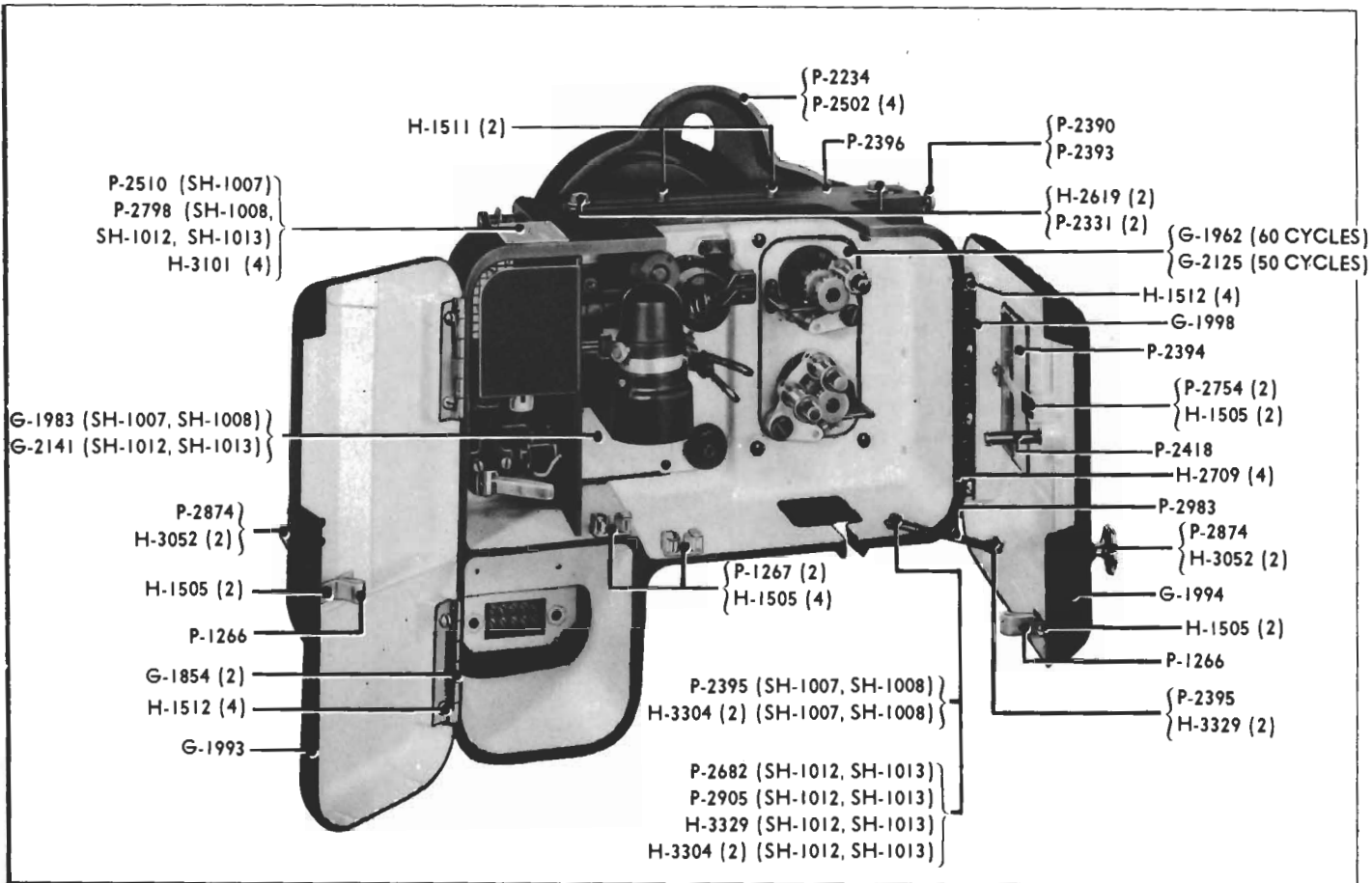

SH-1007 SOUND MECHANISM (Indoor, 60 cycles)  
 SH-1008 SOUND MECHANISM (Indoor, 50 cycles)  
 SH-1012 SOUND MECHANISM (Drive-In, 60 cycles)  
 SH-1013 SOUND MECHANISM (Drive-In, 50 cycles)

**SH-1007 SOUND MECHANISM (Indoor, 60 cycles)**  
**SH-1008 SOUND MECHANISM (Indoor, 50 cycles)**  
**SH-1012 SOUND MECHANISM (Drive-In, 60 cycles)**  
**SH-1013 SOUND MECHANISM (Drive-In, 50 cycles)**

- G-1854 Exciter Lamp Compartment Door Hinge (2)  
G-1962 Gear Box (60 cycles) (parts shown on page 6-3)  
G-1983 Sound Bracket Assembly (SH-1007, SH-1008)  
(Parts shown on page 6-9)  
G-1984 Terminal Strip  
G-1993 Exciter Lamp Compartment Door Complete  
G-1994 Film Compartment Door Complete\*  
G-1998 Film Compartment Door Hinge  
G-2002 Stabilizer  
G-2054 Cable Form  
G-2125 Gear Box (50 cycles) (parts shown on page 6-3)  
G-2141 Sound Bracket Assembly (SH-1012, SH-1013)  
(Parts shown on page 6-9)
- H-1505 Fastening Screw (19)  
H-1507 Terminal Strip Fastening Screw (4)  
H-1511 Mechanism Fastening Screw (2)  
H-1512 Hinge-Door Fastening Screw (8)  
H-2505 Mounting Plate Fastening Screw (3)  
H-2619 Mechanism Bar Fastening Screw (2)  
H-2646 Motor Assembly Mounting Screw (4)  
H-2647 Soundhead Mounting Screw (4)  
H-2709 Hinge-Frame Fastening Screw (8)  
H-3052 Knob Fastening Screw (4)  
H-3101 License-Nameplate Fastening Screw (12)  
H-3304 Door Stop Spacing Washer (2)  
H-3329 Door Stop Washer (2, SH-1007, SH-1008) (3, SH-1012, SH-1013)  
H-3704 Coupling Screw (2)
- P-1145 Cable Clamp Lockwasher  
P-1266 Door Strike (2)  
P-1267 Door Catch (2)  
P-2231 Main Frame  
P-2234 Rear Guard  
P-2285 Terminal Strip Spacer (4)  
P-2331 Mechanism Bar Washer (2)  
P-2390 Mechanism Bar Adjusting Screw Lock Nut  
P-2391 License Plate  
P-2392 License Plate  
P-2393 Mechanism Bar Adjusting Screw  
P-2394 Film Compartment Door Glass  
P-2395 Door Stop Fastening Screw (2, SH-1007, SH-1008) (1, SH-1012, SH-1013)  
P-2396 Mechanism Fastening Bar  
P-2397 Ventilating Screen (2)  
P-2398 Ventilating Screen Frame (2)  
P-2418 Film Compartment Door Stud  
P-2434 Motor Coupling  
P-2502 Rear Guard Fastening Screw (4)  
P-2510 Nameplate (SH-1007)  
P-2647 Connector Mounting Plate  
P-2682 Door Stop Fastening Screw (SH-1012, SH-1013)  
P-2711 Allen Wrench—No. 10 Cap Screw (For H-2709) \*\*  
P-2754 Glass Retaining Clip (2)  
P-2792 Soundhead Mounting Screw Washer (4)  
P-2798 Nameplate (SH-1008, SH-1012, SH-1013)  
P-2874 Knob (2)  
P-2892 Connector, Female  
P-2905 Friction Spring (SH-1012, SH-1013)  
P-2983 Door Stop  
P-3002 Cable Clamp

\* H-1505 (2), H-3329 (2), P-2394, P-2395 and P-2754 (2) are not included and must be ordered separately.

\*\* Non-Component Item. Order Separately.

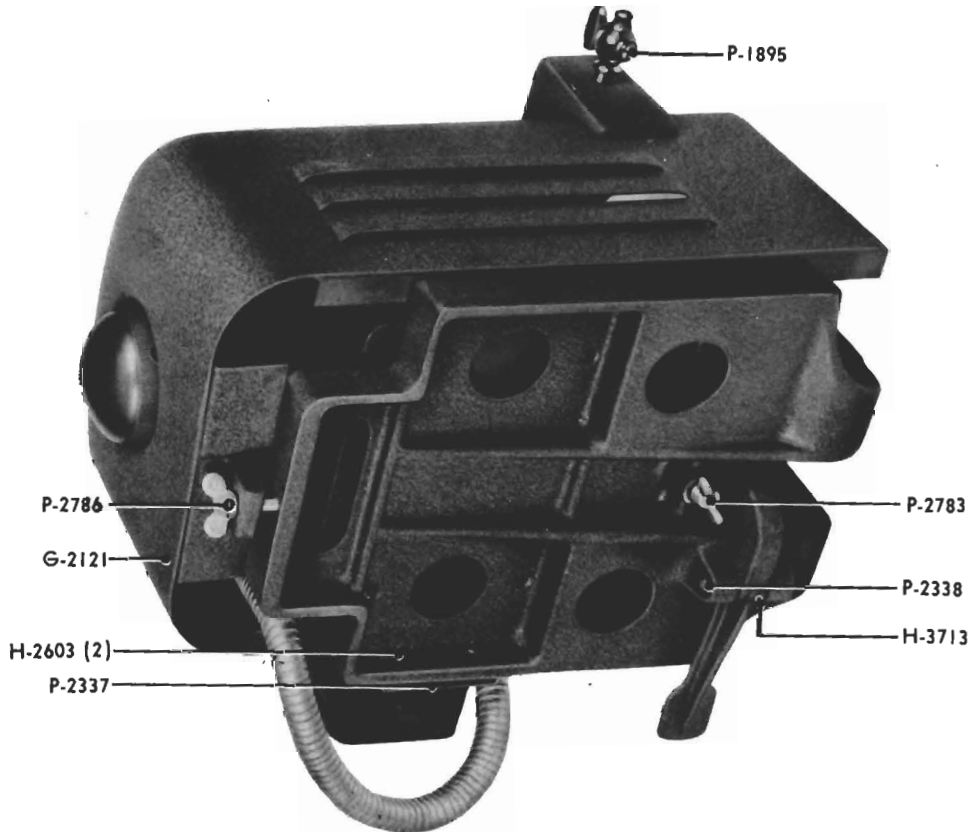
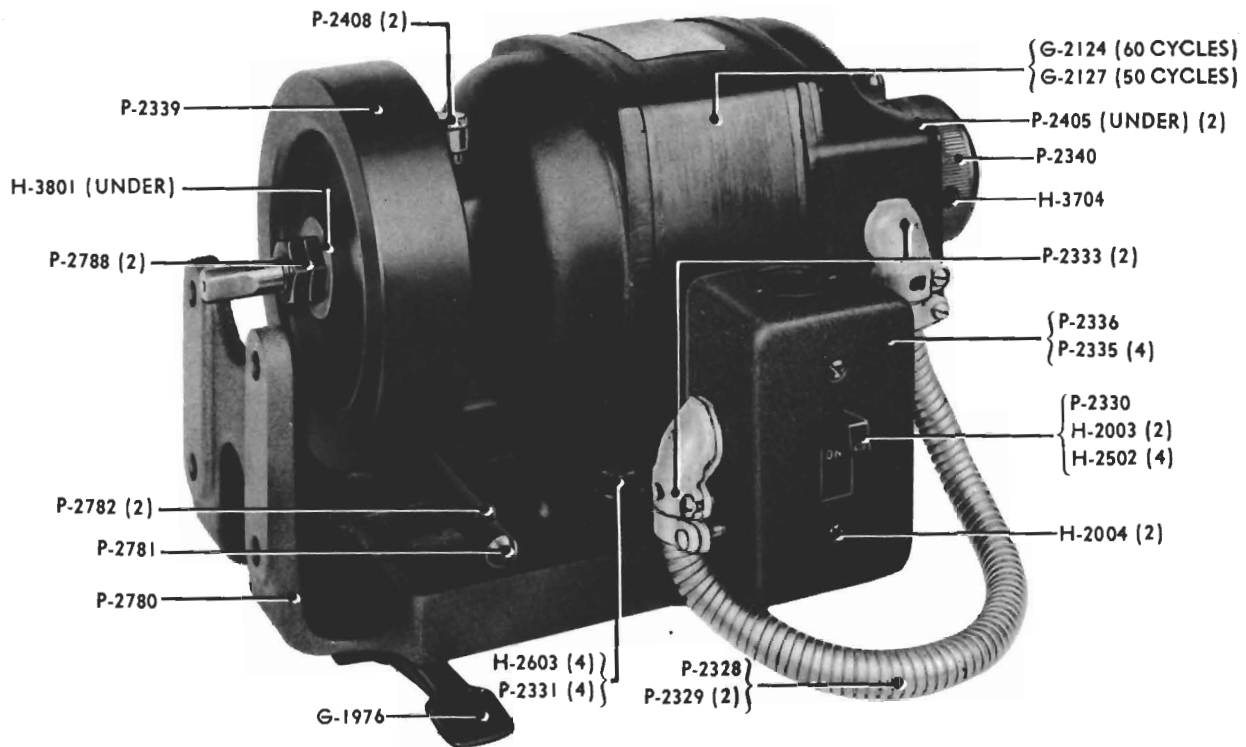

SH-1009 MOTOR ASSEMBLY (60 cycles)  
 SH-1010 MOTOR ASSEMBLY (50 cycles)

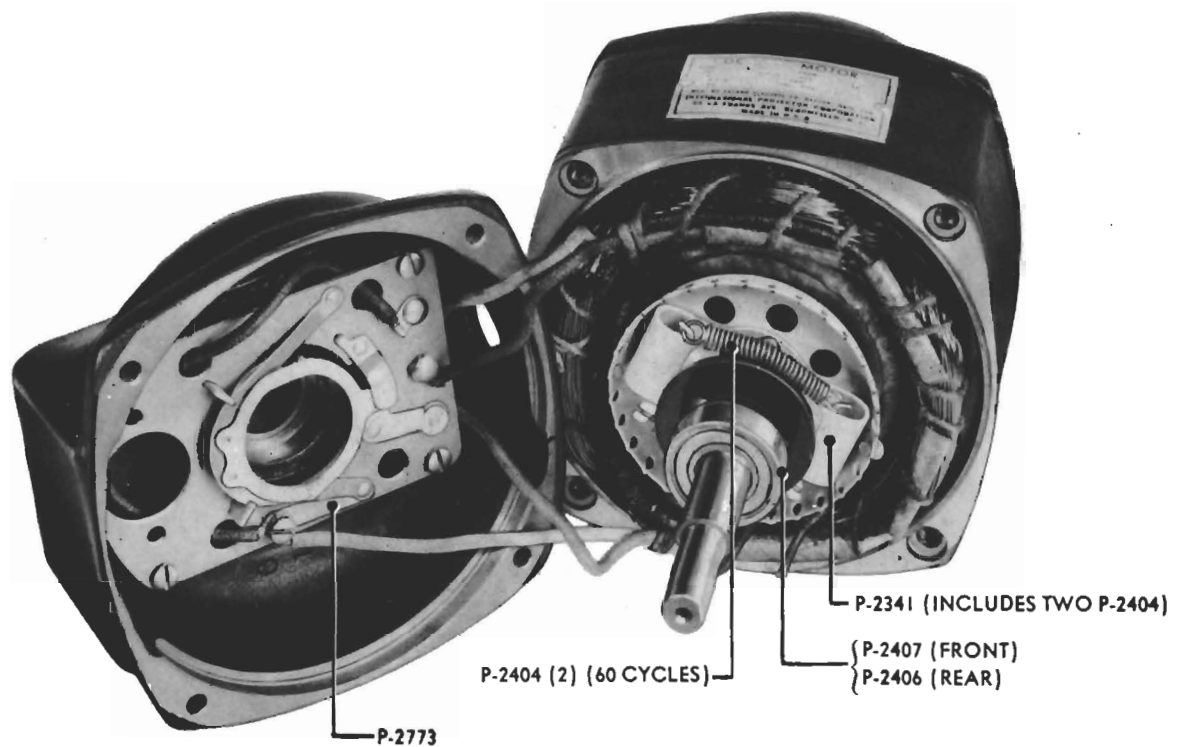

**SH-1009 MOTOR ASSEMBLY (60 cycles)**  
**SH-1010 MOTOR ASSEMBLY (50 cycles)**

G-1976	Brake Lever	P-2335	Switch Box Fastening Screw (4)
G-2121	Motor Cover (includes P-2786)	P-2336	Motor Switch Box
G-2124	Motor, 60 cycle	P-2337	Switch Box Fastening Plate
<del>G-2127</del>	<del>Motor, 50 cycle</del>	P-2338	Motor Brake Lever Pivot
H-2003	Switch Fastening Screw (2)	P-2339	Motor Flywheel
H-2004	Switch Cover Fastening Screw (2)	P-2340	Motor Knob
H-2502	Switch Terminal Screw (4)	P-2341	Rotating Element Motor Centrifugal Switch (includes two P-2404)
H-2603	Motor-Switch Mounting Plate Fastening Screw (6)	P-2404	Centrifugal Switch Spring (2)
H-3704	Motor Knob Set Screw	P-2405	Motor Resilient Mounting Ring (2)
H-3713	Brake Lever Set Screw	P-2406	Motor Rear Ball Bearing
H-3801	Motor Shaft Key	P-2407	Motor Front Ball Bearing
P-1395	Allen Wrench— $\frac{1}{4}$ " Set Screw (For H-3704) *	P-2408	Motor Grease Cup (2)
P-1895	Oil Drain Petcock	P-2773	Stationary Element Motor Centrifugal Switch
P-2328	Flexible Conduit	P-2780	Motor Bracket
P-2329	Flexible Conduit Fibre Bushing (2)	P-2781	Motor Cover Clamping Bar
P-2330	Motor Switch	P-2782	Clamping Bar Locating Screw (2)
P-2331	Motor Mounting Washer (4)	P-2783	Clamping Bar Tightening Screw
P-2333	Flexible Conduit 90° Connector (2)	P-2786	Cover Fastening Screw
		P-2788	Motor Flywheel Fastening Nut (2)
		P-2794	Allen Wrench—No. 8 Set Screw (For H-3713) *

\* Non-Component Item. Order Separately.

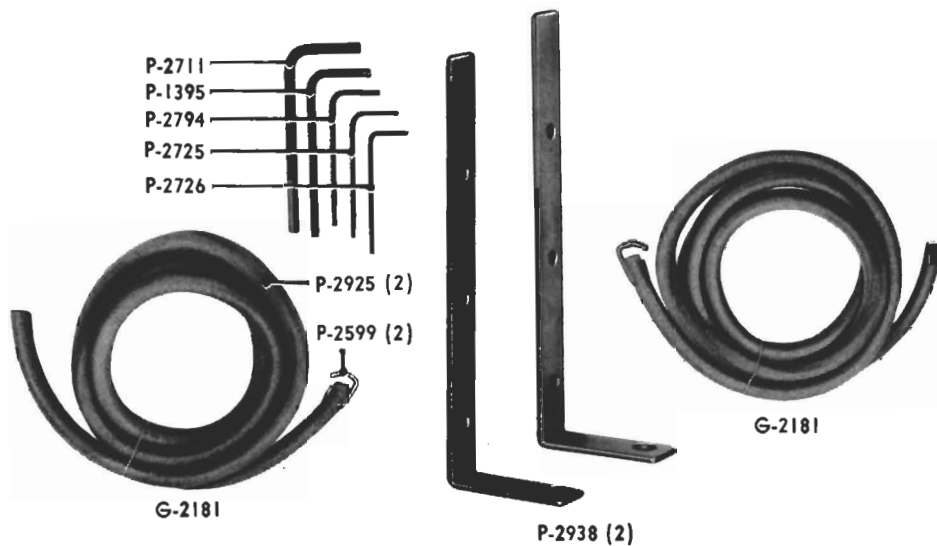

### SH-1011 SOUND MECHANISM ACCESSORY PARTS

- G-2181 Round Leather Belt and Hook (2)
- P-1395 Allen Wrench—1/4" Set Screw and No. 8 Cap Screw
- P-2599 Belt Hook (2)
- P-2711 Allen Wrench—5/16" Set Screw and No. 10 Cap Screw
- P-2725 Allen Wrench—No. 6 Set Screw and No. 4 Flat Head Screw
- P-2726 Bristo Wrench—No. 6
- P-2794 Allen Wrench—No. 8 Set Screw and No. 4 Cap Screw
- P-2925 Round Leather Belt (2)
- P-2938 Conduit Strap (2)

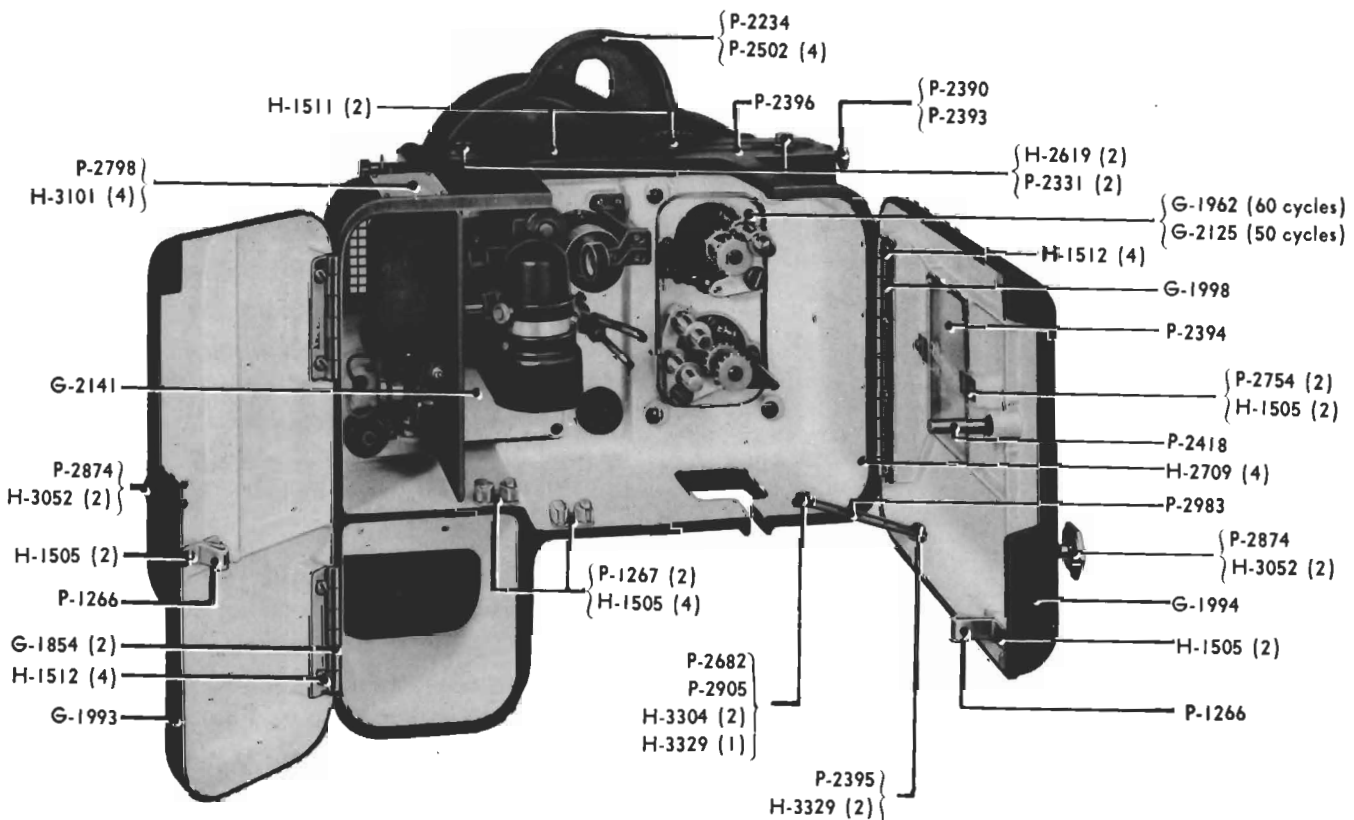

SH-1020 SOUND MECHANISM (Indoor and Drive-In, 60 cycles)  
 SH-1021 SOUND MECHANISM (Indoor and Drive-In, 50 cycles)

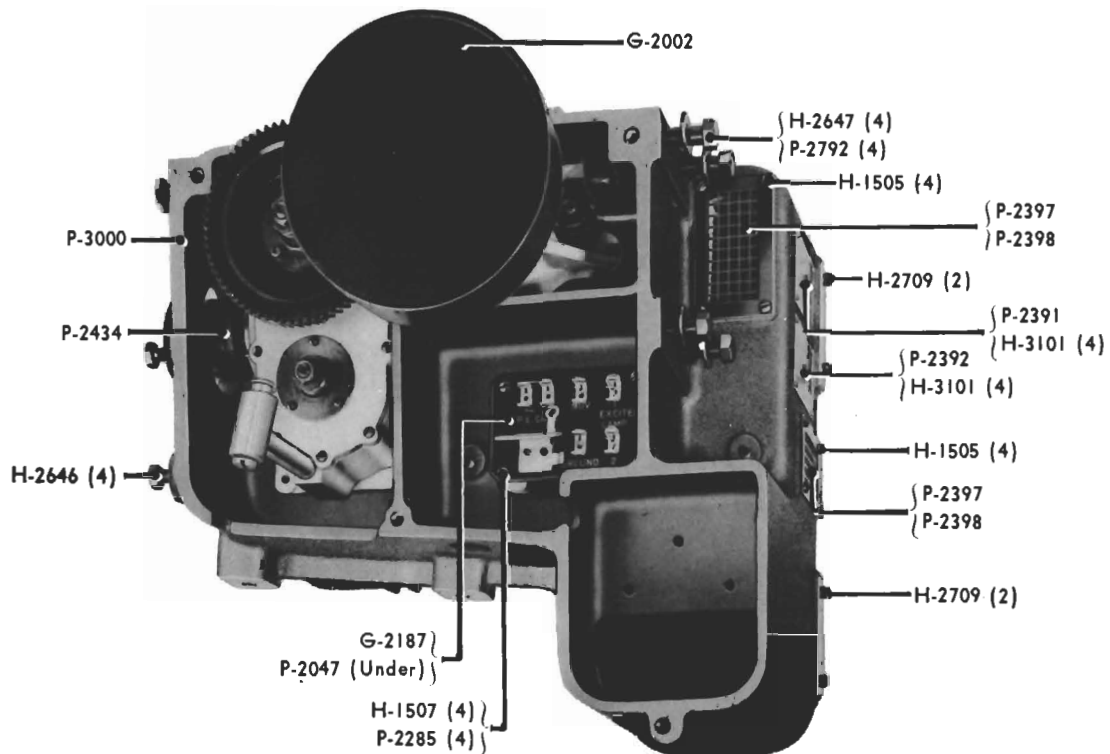

**SH-1020 SOUND MECHANISM (Indoor and Drive-In, 60 cycles)**  
**SH-1021 SOUND MECHANISM (Indoor and Drive-In, 50 cycles)**

G-1854	Exciter Lamp Compartment Door Hinge (2)	P-1267	Door Catch (2)
G-1962	Gear Box (60 cycles) (Parts shown on page 6-3)	P-2047	Resistor, 0.51 Meg, 1 Watt
G-1993	Exciter Lamp Compartment Door Complete	P-2234	Rear Guard
G-1994	Film Compartment Door Complete*	P-2285	Terminal Strip Spacer (4)
G-1998	Film Compartment Door Hinge	P-2331	Mechanism Bar Washer (2)
G-2002	Stabilizer	P-2390	Mechanism Bar Adjusting Screw Lock Nut
G-2125	Gear Box (50 cycles) (Parts shown on page 6-3)	P-2391	License Plate
G-2141	Sound Bracket Assembly (Parts shown on page 6-9)	P-2392	License Plate
G-2187	Terminal Strip	P-2393	Mechanism Bar Adjusting Screw
H-1505	Fastening Screw (14)	P-2394	Film Compartment Door Glass
H-1507	Terminal Strip Fastening Screw (4)	P-2395	Door Stop Fastening Screw
H-1511	Mechanism Fastening Screw (2)	P-2396	Mechanism Fastening Bar
H-1512	Hinge-Door Fastening Screw (8)	P-2397	Ventilating Screen (2)
H-2619	Mechanism Bar Fastening Screw (2)	P-2398	Ventilating Screen Frame (2)
H-2646	Motor Assembly Mounting Screw (4)	P-2418	Film Compartment Door Stud
H-2647	Soundhead Mounting Screw (4)	P-2434	Motor Coupling
H-2709	Hinge-Frame Fastening Screw (8)	P-2502	Rear Guard Fastening Screw (4)
H-3052	Knob Fastening Screw (4)	P-2682	Door Stop Fastening Screw
H-3101	License-Nameplate Fastening Screw (12)	P-2711	Allen Wrench — $\frac{5}{16}$ " Set Screw and No. 10 Cap Screw (For H-2709) **
H-3304	Door Stop Spacing Washer (2)	P-2754	Glass Retaining Clip (2)
H-3329	Door Stop Washer (3)	P-2792	Soundhead Mounting Screw Washer (4)
P-1266	Door Strike (2)	P-2798	Nameplate
		P-2874	Knob (2)
		P-2905	Friction Spring
		P-2983	Door Stop
		P-3000	Main Frame

\* H-1505 (2), H-3329 (2), P-2394, P-2395 and P-2754 (2) are not included and must be ordered separately.

\*\* Non-Component Item. Order Separately.

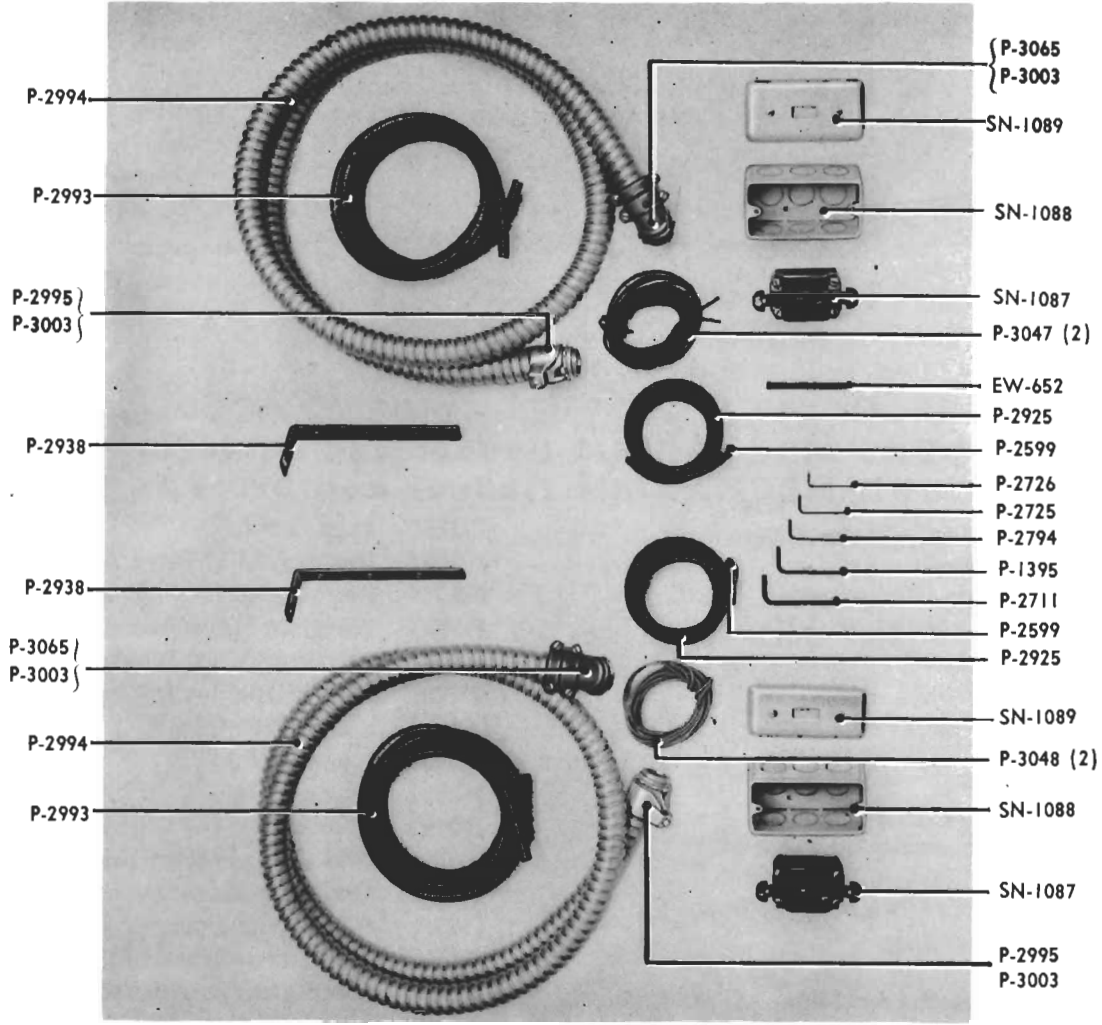

SH-1022 SOUND MECHANISM  
ACCESSORY PARTS

## SH-1022 SOUND MECHANISM ACCESSORY PARTS

- P-1395 Allen Wrench— $\frac{1}{4}$ " Set Screw and No. 8 Cap Screw
- P-2599 Belt Hook (2)
- P-2711 Allen Wrench— $\frac{3}{16}$ " Set Screw and No. 10 Cap Screw
- P-2725 Allen Wrench—No. 5 or No. 6 Set Screw and No. 4 Fl. Hd. Screw
- P-2726 Bristo Wrench—No. 6
- P-2794 Allen Wrench—No. 8 Set Screw and No. 4 Cap Screw
- P-2925 Round Leather Belt (2)
- P-2938 Cable Clamp Bracket (2)
- P-2993 Coaxial Cable—84" (2)
- P-2994 Flexible Conduit— $\frac{3}{4}$ " (2)
- P-2995 Flexible Conduit Straight Connector— $\frac{3}{4}$ " (2)
- P-3003 Conduit Connector Insulating Bushing— $\frac{3}{4}$ " (4)
- P-3047 Black Hookup Wire—84" (2)
- P-3048 Red Hookup Wire—84" (2)
- P-3065 Flexible Conduit 45° Connector— $\frac{3}{4}$ " (2)
  
- SN-1087 Changeover Switch and Screws (2)
- SN-1088 Changeover Switch Box (2)
- SN-1089 Switch Box Cover and Screws (2)
  
- EW-652 Black Varnished Cotton Sleaving—3"



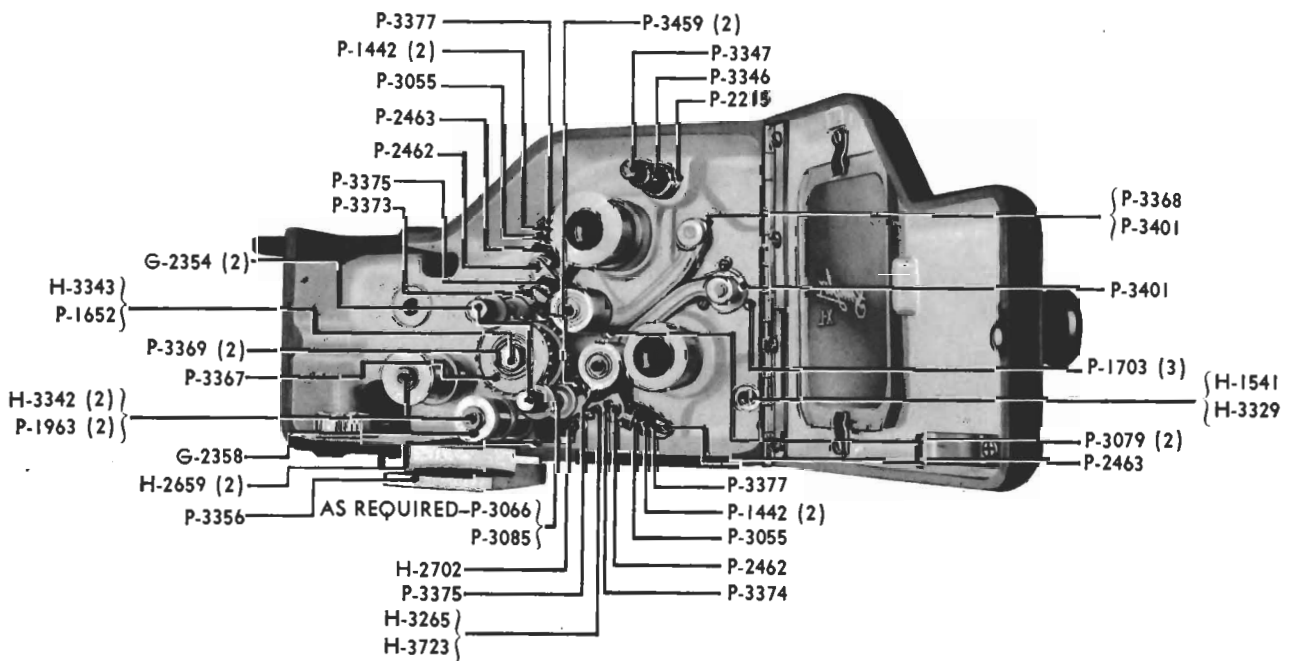
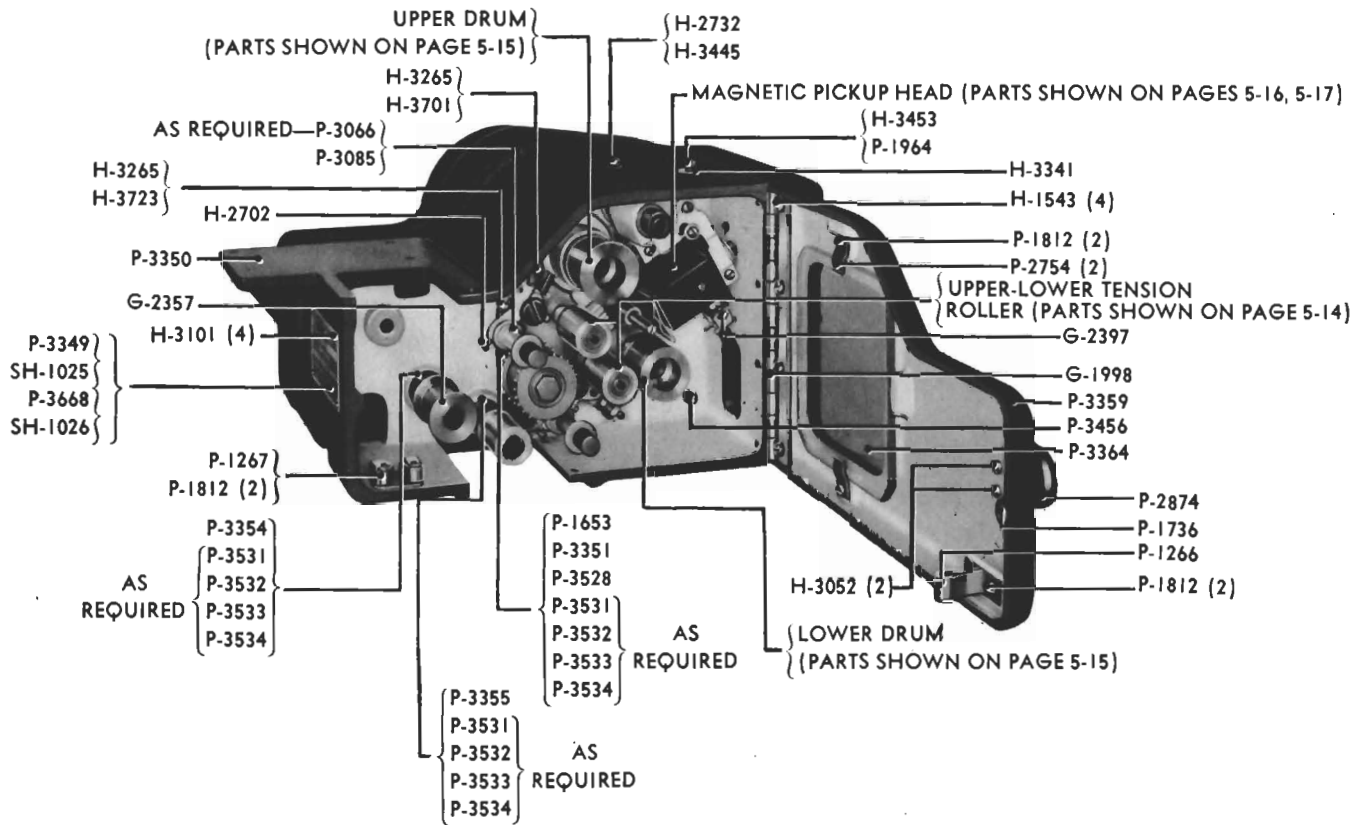

SH-1025 MAGNETIC SOUNDHEAD  
SH-1026 MAGNETIC SOUNDHEAD

**SH-1025 MAGNETIC SOUNDHEAD  
SH-1026 MAGNETIC SOUNDHEAD  
(Pages 5-8 thru 5-17)**

**FILM COMPARTMENT AND DOOR PARTS**

G-1998	Film Compartment Door Hinge
G-2354	Pad Roller Stud and Knob (2)
G-2357	Upper Guide Roller ~
G-2358	Lower Guide Roller ~
G-2397	Connector and Cable
H-1541	Tension Roller Adjustment Locking Screw
H-1543	Compartment Door Hinge Fastening Screw (4)
H-2659	Closure Plate Fastening Screw (2)
H-2702	Pad Roller Stud Set Screw (2)
H-2732	Lateral Adjustment Stud Fastening Screw
H-3052	Compartment Door Knob Fastening Screw (2)
H-3101	Nameplate Fastening Screw (4)
H-3265	Pad Roller Adjusting-Upper Tension Arm Stop Screw Fastening Nut (3)
H-3329	Tension Roller Adjustment Locking Screw Washer
H-3341	Lateral Adjustment Locking Screw Washer
H-3342	Upper-Lower Guide Roller Retaining Washer (2)
H-3343	Sprocket Retaining Washer
H-3445	Lateral Adjustment Stud Lockwasher
H-3453	Lateral Adjustment Lockwasher
H-3701	Pad Roller Arm Upper Tension Roller Arm Stop Screw
H-3723	Pad Roller Arm Adjusting Screw (2)
P-1266	Door Strike
P-1267	Door Catch
P-1442	Pad Roller Arm Spring Retainer (4)
P-1652	Sprocket Retaining Screw
P-1653	Sprocket End Thrust Spring
P-1703	Damper Fastening Screw (3)
P-1736	Door Bumper
P-1812	Door Catch-Strike-Glass Retaining Clip Fastening Screw (6)
P-1963	Upper-Lower Guide Roller Retaining Screw (2)
P-1964	Lateral Adjustment Locking Screw
P-2215	Lateral Adjustment Spring
P-2462	Spring Guide Pivot Pin (2)
P-2463	Spring Guide (2)
P-2754	Glass Retaining Clip (2)
P-2874	Film Compartment Door Knob
P-3055	Pad Roller Spring (2)
P-3066	Pad Roller Spacing Washer (As required)
P-3079	Upper-Lower Tension Roller Arm Stop Pin (2)
P-3085	Pad Roller (2)
P-3346	Lateral Adjusting Bracket Stud
P-3347	Lateral Adjustment Knob
P-3349	Nameplate (SH-1025)
P-3350	Frame
P-3351	Sprocket Stud
P-3354	Upper Guide Roller Stud
P-3355	Lower Guide Roller Stud
P-3356	Closure Plate
P-3359	Film Compartment Door
P-3364	Film Compartment Door Glass
P-3367	Sprocket
P-3368	Upper Tension Roller Arm Shaft Ball Bearing
P-3369	Sprocket Ball Bearing (2)
P-3373	Upper Pad Roller Arm
P-3374	Lower Pad Roller Arm
P-3375	Pad Roller Arm Pivot Stud (2)
P-3377	Pad Roller Arm Spring Guide Pin (2)
P-3401	Upper-Lower Tension Roller Arm Bearing Washer (2)
P-3456	Upper-Lower Tension Roller Adjusting Screw
P-3459	Upper-Lower Pad Roller Adjusting Screw Stop Stud (2)
P-3528	Sprocket End Thrust Washer
P-3531	Upper-Lower Guide Roller-Sprocket Stud Shim (.004 Thick)— As required
P-3532	Upper-Lower Guide Roller-Sprocket Stud Shim (.005 Thick)— As required
P-3533	Upper-Lower Guide Roller-Sprocket Stud Shim (.007 Thick)— As required
P-3534	Upper-Lower Guide Roller-Sprocket Stud Shim (.011 Thick)— As required
P-3668	Nameplate (SH-1026)

Upper Drum (Parts shown on Page 5-15)

Lower Drum (Parts shown on Page 5-15)

Upper-Lower Tension Roller (Parts shown on Page 5-14)

Magnetic Pickup Head (Parts shown on Pages 5-16, 5-17)

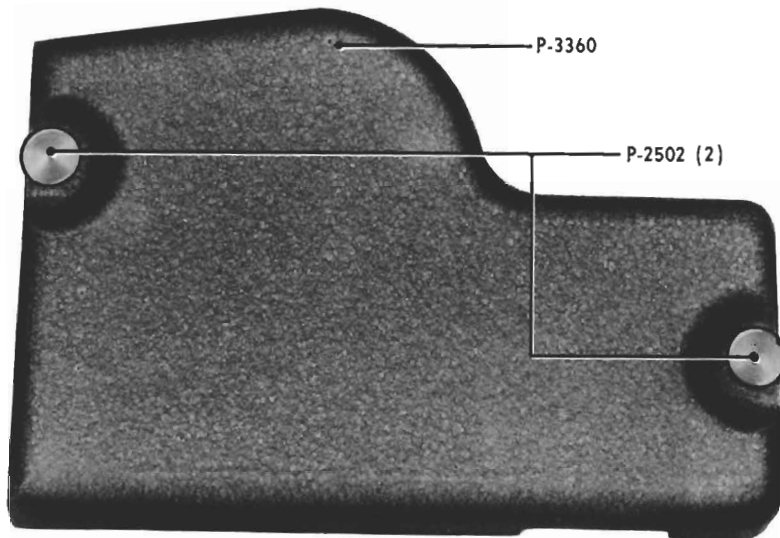
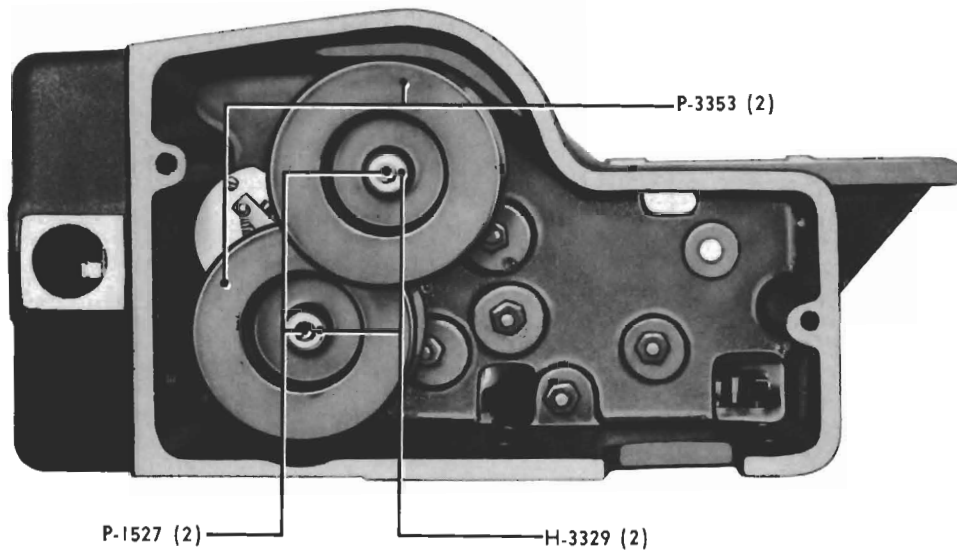

SH-1025 MAGNETIC SOUNDHEAD  
SH-1026 MAGNETIC SOUNDHEAD

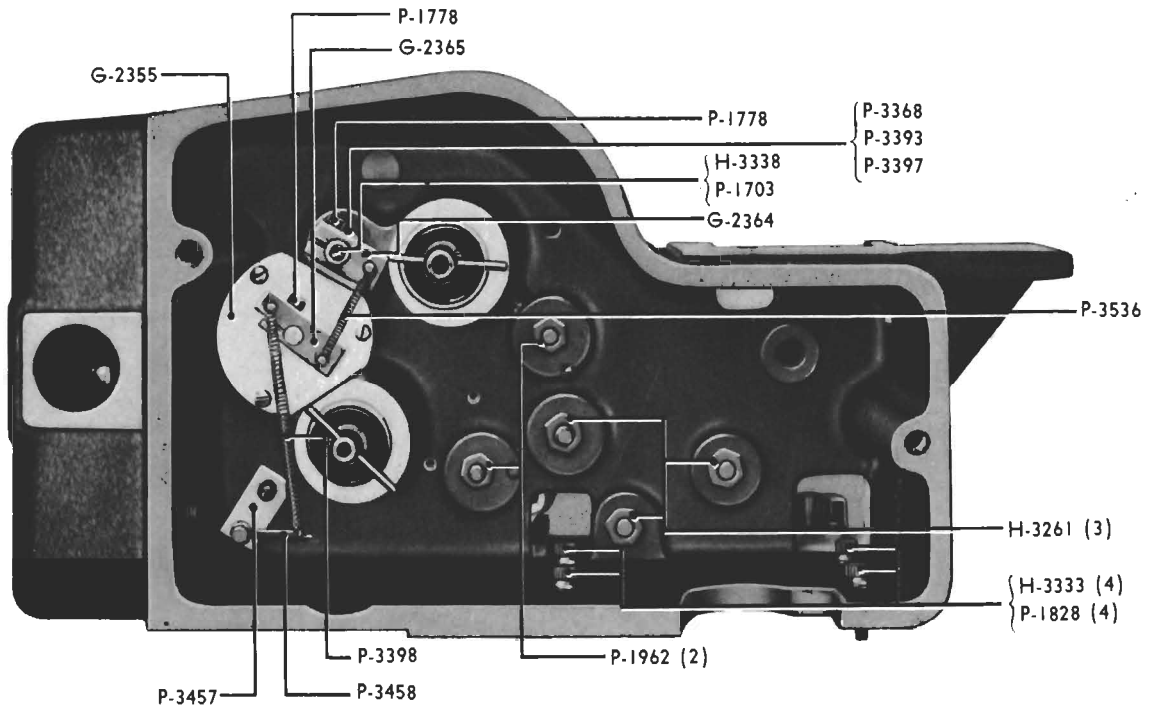

**SH-1025 MAGNETIC SOUNDHEAD  
SH-1026 MAGNETIC SOUNDHEAD**  
(Pages 5-8 thru 5-17)

**FLYWHEEL COMPARTMENT AND COVER PARTS**

G-2355	Damper (Includes G-2365)	P-1828	Soundhead Mounting Screw (4)
G-2364	Upper Tension Roller Spring Arm (Includes P-1778)	P-1962	Upper-Lower Pad Roller Arm Pivot Screw Fastening Nut (2)
G-2365	Lower Tension Roller Spring Arm (Includes P-1778)	P-2502	Flywheel Compartment Cover Captive Fastening Screw (2)
H-3261	Upper-Lower Guide Roller- Sprocket Stud Fastening Nut (3)	P-3353	Flywheel (2)
H-3329	Flywheel Retaining Washer (2)	P-3360	Flywheel Compartment Cover
H-3333	Soundhead Mounting Screw Washer (4)	P-3368	Upper Tension Roller Arm Ball Bearing
H-3338	Upper Tension Roller Spring Arm Retaining Washer	P-3393	Upper Tension Roller Arm Shaft Step Washer
P-1527	Flywheel Fastening Screw (2)	P-3397	Upper Tension Roller Arm Shaft End Thrust Spring
P-1703	Upper Tension Roller Spring Arm Retaining Screw	P-3398	Upper-Lower Tension Roller Centering Spring
P-1778	Spring Arm Locking Screw (2), (1) Included with G-2364 and G-2365)	P-3457	Centering Spring Adjusting Screw Locking Plate
		P-3458	Centering Spring Stud
		P-3536	Upper and Lower Tension Roller Control and Filter Spring

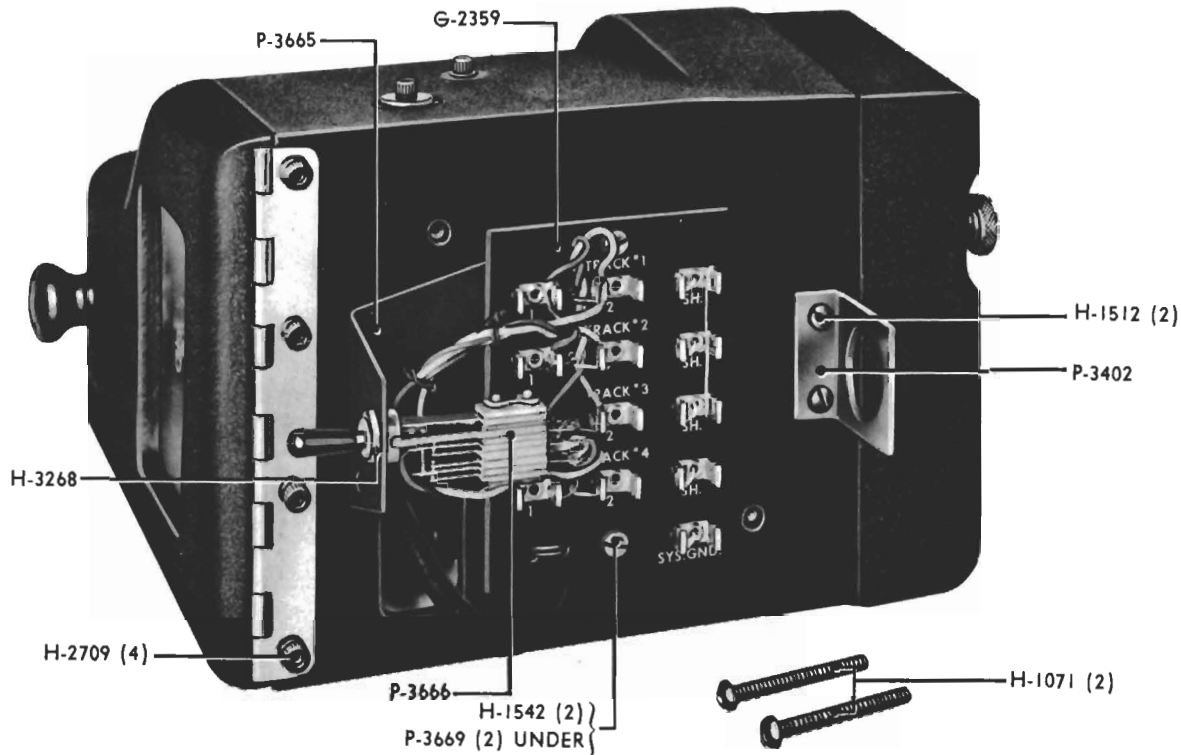

## SH-1026 MAGNETIC SOUNDHEAD (Pages 5-8 thru 5-16)

### TERMINAL STRIP COMPARTMENT AND COVER PARTS (Pages 5-8 thru 5-16)

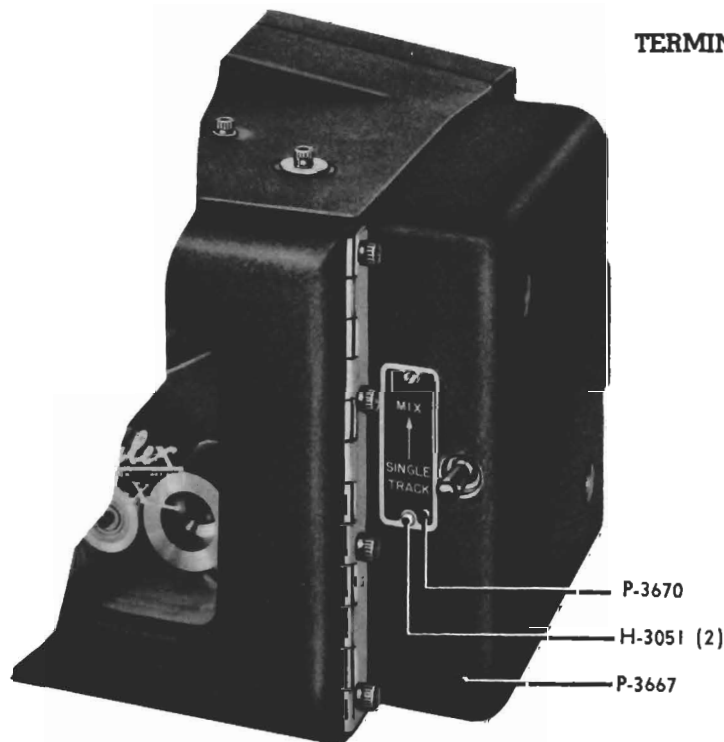

G-2359	Terminal Strip
H-1071	Cover Fastening Screw (2)
H-1512	Conduit Connector Bracket Fastening Screw (2)
H-1542	Terminal Strip Fastening Screw (2)
H-2709	Frame Door Hinge Fastening Screw (4)
H-3051	Mix Switch Nameplate Fastening Screw (2)
H-3268	Mix Switch Fastening Nut
P-3402	Conduit Connector Bracket
P-3665	Mix Switch Mounting Bracket
P-3666	Mix Switch
P-3667	Terminal Strip Cover
P-3669	Terminal Strip Spacer (2)
P-3670	Mix Switch Nameplate

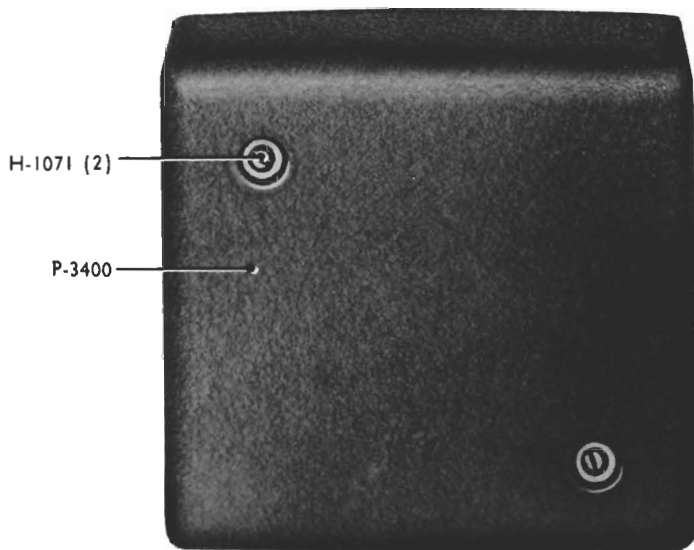
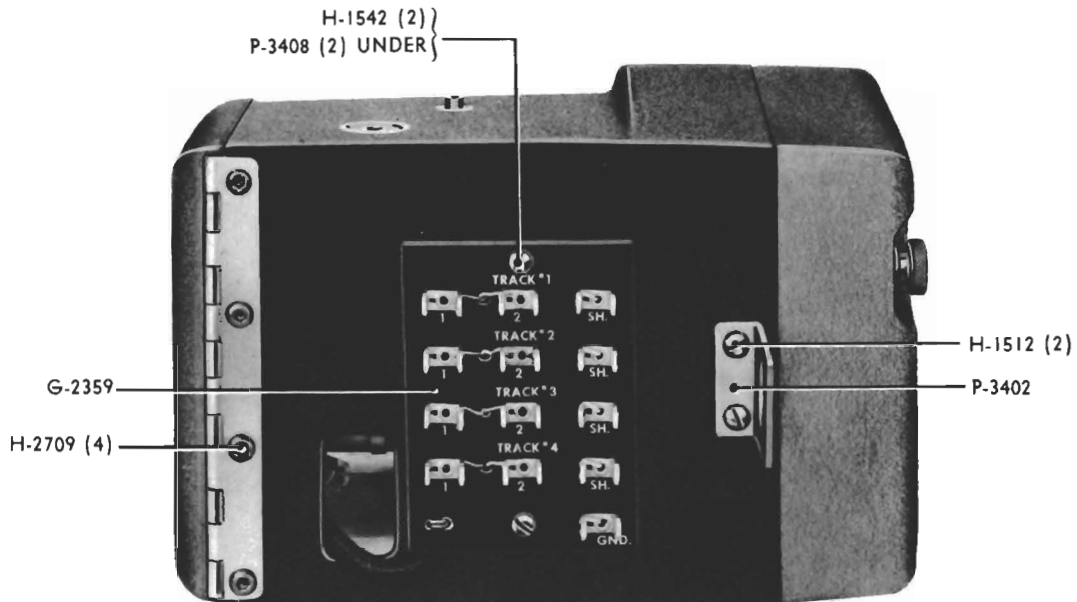

**SH-1025 MAGNETIC SOUNDHEAD**  
 (Pages 5-8 thru 5-17)

**TERMINAL STRIP COMPARTMENT AND COVER PARTS**

- G-2359 Terminal Strip
- H-1071 Cover Fastening Screw (2)
- H-1512 Conduit Connector Bracket Fastening Screw (2)
- H-1542 Terminal Strip Fastening Screw (2)
- H-2709 Frame Door Hinge Fastening Screw (4)
- P-3400 Terminal Strip Cover
- P-3402 Conduit Connector Bracket
- P-3408 Terminal Strip Spacer (2)

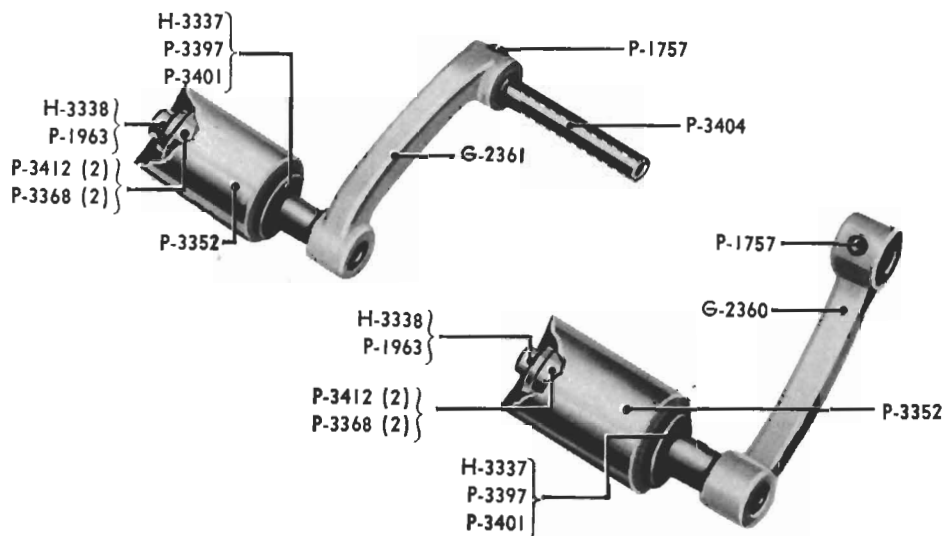

**SH-1025 MAGNETIC SOUNDHEAD  
SH-1026 MAGNETIC SOUNDHEAD  
(Pages 5-8 thru 5-17)**

**UPPER AND LOWER TENSION ROLLER PARTS**

G-2360	Lower Tension Arm
G-2361	Upper Tension Arm
H-3337	Tension Roller Shaft Washer (2)
H-3338	Tension Roller Retaining Washer (2)
P-1757	Tension Arm Shaft Fastening Screw (2)
P-1963	Tension Roller Retaining Screw (2)
P-3352	Tension Roller (2)
P-3368	Tension Roller Ball Bearing (4)
P-3397	Tension Roller End Thrust Spring (2)
P-3401	Tension Roller Thrust Washer (2)
P-3404	Upper Tension Roller Arm Shaft
P-3412	Tension Roller Bearing Retaining Ring (4)

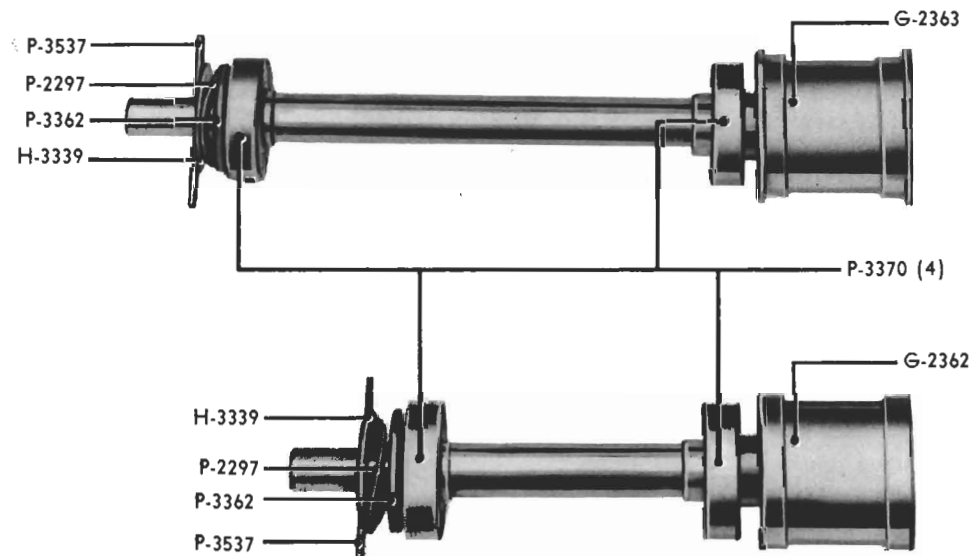

**SH-1025 MAGNETIC SOUNDHEAD  
SH-1026 MAGNETIC SOUNDHEAD  
(Pages 5-8 thru 5-17)**

**UPPER AND LOWER DRUM AND ASSOCIATED PARTS**

G-2362	Lower Drum
G-2363	Upper Drum
H-3339	Upper-Lower Drum Shaft Washer (2)
P-2297	Upper-Lower Drum Shaft End Thrust Spring (2)
P-3362	Upper-Lower Drum Shaft Step Washer (2)
P-3370	Upper-Lower Drum Shaft Ball Bearing (4)
P-3537	Upper-Lower Drum Shaft Pin (2)



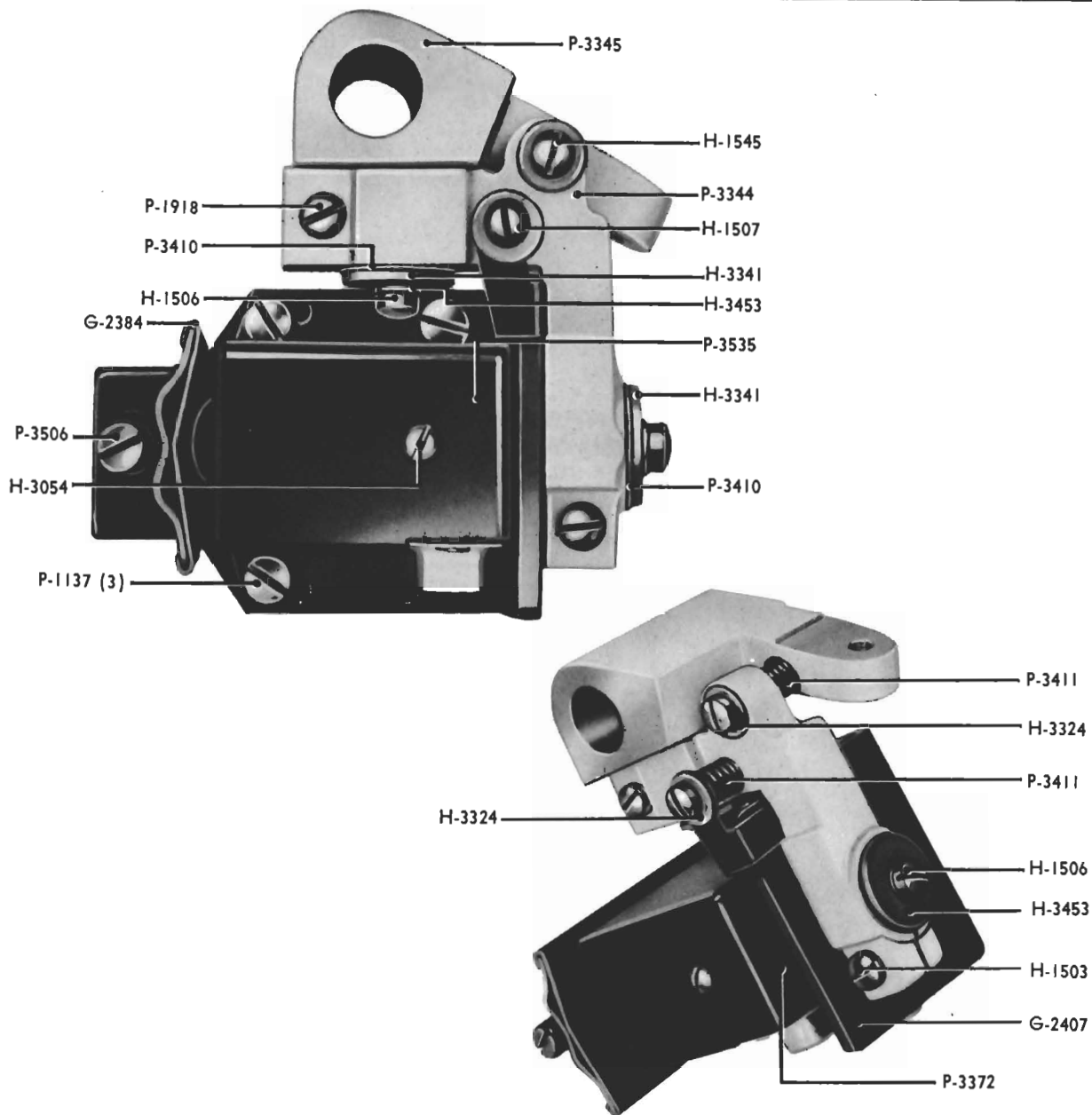

**SH-1025 MAGNETIC SOUNDHEAD  
SH-1026 MAGNETIC SOUNDHEAD  
(Pages 5-8 thru 5-17)**

**MAGNETIC PICKUP HEAD AND MOUNTING PARTS  
(Current Type)**

G-2384	Pickup Head Shield	H-3453	Retaining Washer Lockwasher (2)
G-2407	Azimuth Adjusting Bracket	P-1137	Pickup Head Fastening Screw (3)
H-1503	Azimuth Adjusting Locking Screw	P-1918	Pressure Adjustment Locking Screw
H-1506	Azimuth-Lateral Adjusting Bracket Retaining Screw (2)	P-3344	Pressure Adjusting Arm
H-1507	Azimuth Adjusting Screw	P-3345	Lateral Adjusting and Support Bracket
H-1545	Pressure Adjusting Screw	P-3372	Pickup Head
H-3054	Pickup Head Housing Shield Fastening Screw	P-3410	Azimuth-Lateral Adjusting Bracket Tension Spring (2)
H-3324	Azimuth Adjusting Bracket-Pressure Adjusting Arm Washer (2)	P-3411	Azimuth-Pressure Adjusting Tension Spring (2)
H-3341	Azimuth-Lateral Adjusting Bracket Retaining Washer (2)	P-3506	Pickup Head Shield Fastening Screw
		P-3535	Pickup Head Housing Shield

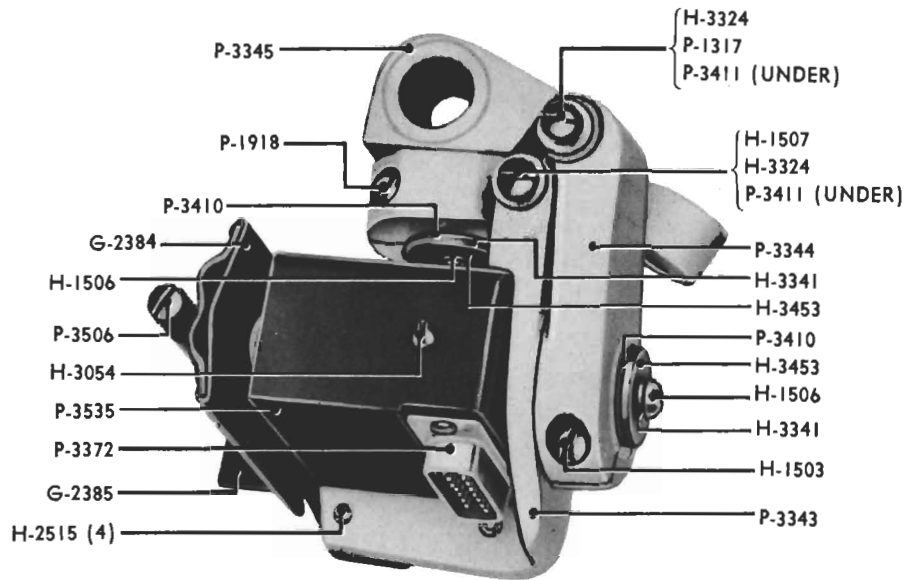

## SH-1025 MAGNETIC SOUNDHEAD (Pages 5-8 thru 5-17)

### MAGNETIC PICKUP HEAD AND MOUNTING PARTS (First Type)

G-2384	Pickup Head Shield
**G-2385	Pickup Head Shield Mounting Plate
H-1503	Azimuth Adjustment Locking Screw
H-1506	Azimuth-Lateral Adjusting Bracket Retaining Screw (2)
H-1507	Azimuth Adjusting Screw
H-2515	Pickup Head-Shield Mounting Plate Fastening Screw (4)
H-3054	Pickup Head Housing Shield Fastening Screw
H-3324	Azimuth Adjusting Bracket-Pressure Adjusting Arm Washer (2)
H-3341	Azimuth-Lateral Adjusting Bracket Retaining Washer (2)
H-3453	Retaining Washer Lockwasher (2)
P-1317	Pressure Adjusting Screw
P-1918	Pressure Adjustment Locking Screw
**P-3343	Azimuth Adjusting Bracket
*P-3344	Pressure Adjusting Arm
P-3345	Lateral Adjusting and Support Bracket
P-3372	Pickup Head
P-3410	Azimuth-Lateral Adjusting Bracket Tension Spring (2)
P-3411	Azimuth-Pressure Adjusting Tension Spring (2)
P-3506	Pickup Head Shield Fastening Screw
P-3535	Pickup Head Housing Shield

\* P-3344 has been redesigned retaining the same part number. When replacing, discard P-1317 and replace with H-1545.

\*\* P-3343 or G-2385 replaced with G-2407 and (3) P-1137. Discard P-3343, G-2385 and (4) H-2515. Location of new parts shown on current type pickup head views.

# SECTION VI

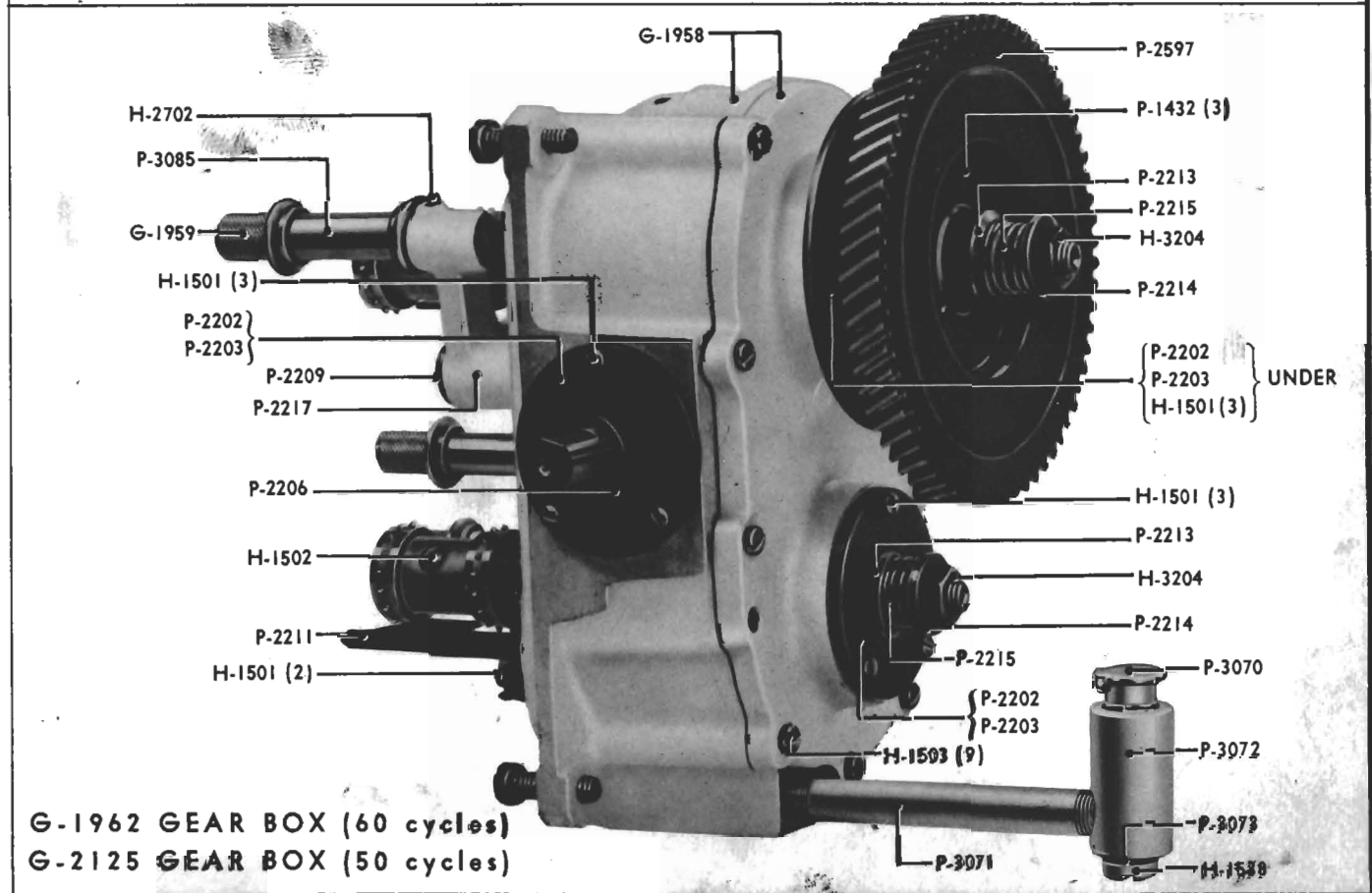
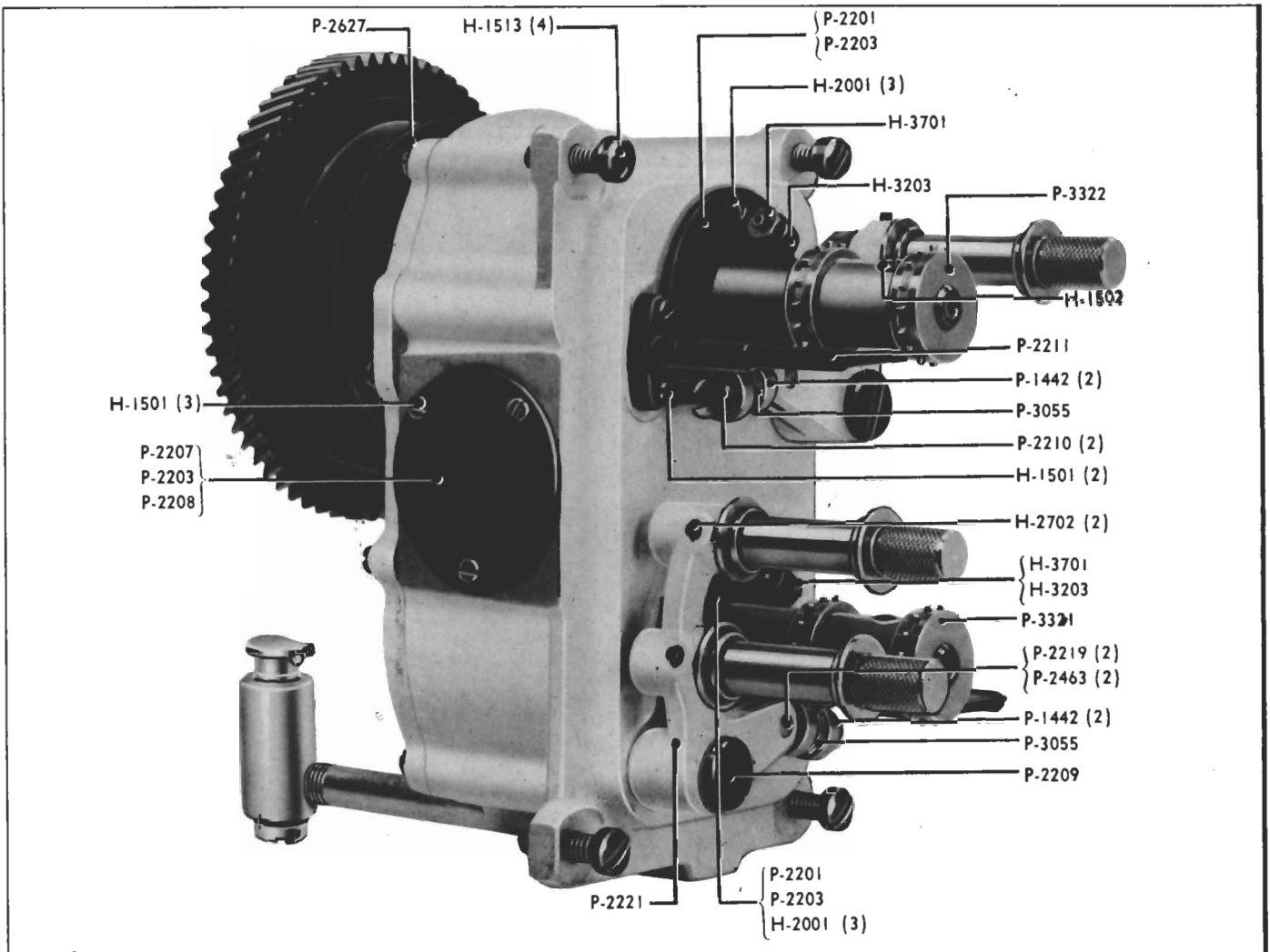

**G-1962 GEAR BOX (60 cycles)**  
**G-2125 GEAR BOX (50 cycles)**

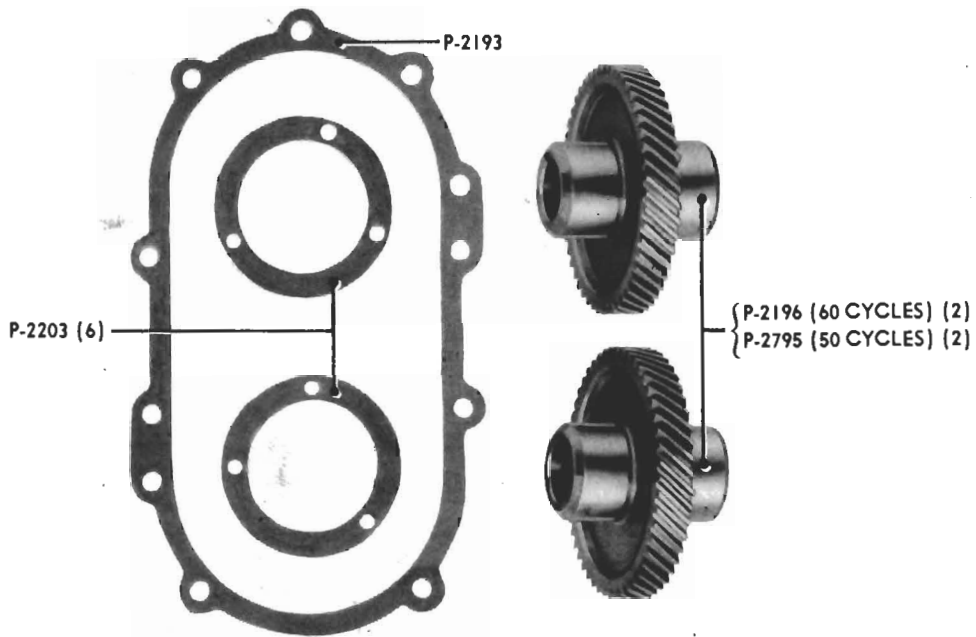
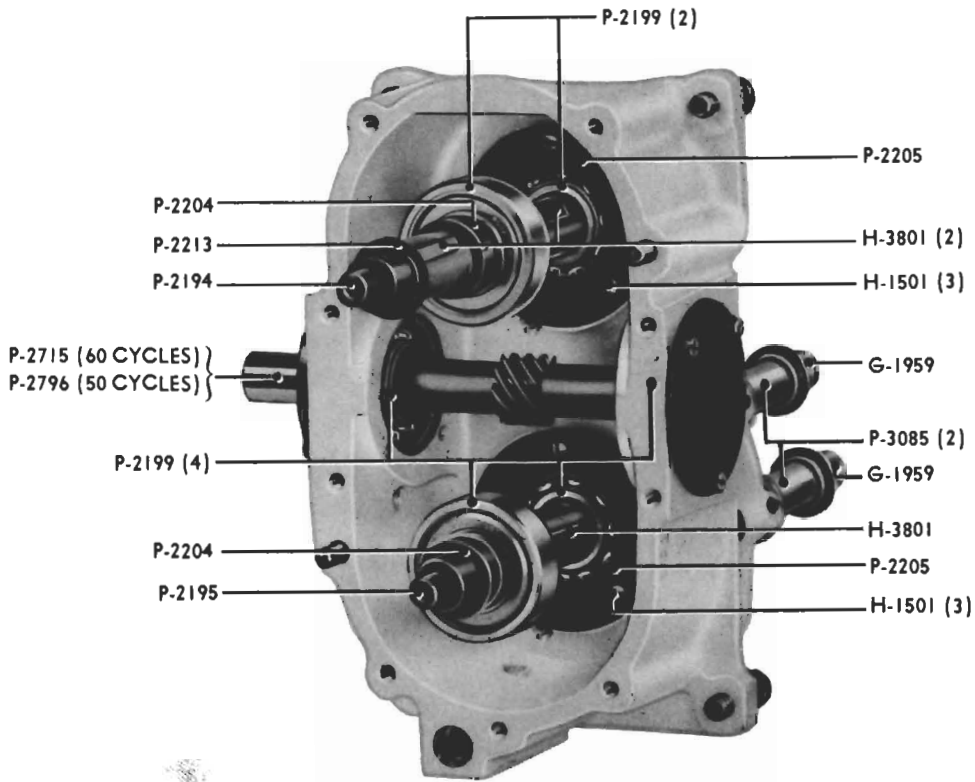

G-1962 GEAR BOX (60 cycles)  
 G-2125 GEAR BOX (50 cycles)

## G-1962 GEAR BOX (60 cycles)

## G-2125 GEAR BOX (50 cycles)

G-1958	Gear Box and Cover	P-2206	Drive Bearing Oil Slinger
G-1959	Pad Roller Stud and Knob (3)	P-2207	Pinion Bearing Outer Retainer
***G-2334	Modification Kit (See Note 1)	P-2208	Pinion Bearing Loading Spring
H-1501	Retainer Plate-Stripper Fastening Screw (22)	P-2209	Pad Roller Arm Fastening Screw (2)
H-1502	Sprocket Fastening Screw (2)	P-2210	Pad Roller Arm Spring Stud (2)
H-1503	Cover Fastening Screw (9)	P-2211	Stripper Plate (2)
H-1513	Gear Box Fastening Screw (4)*	P-2213	Shaft Spring Inner Washer (2)
H-1538	Oil Drain Screw	P-2214	Shaft Spring Outer Washer (2)
H-2001	Retainer Plate Fastening Screw (6)	P-2215	Sound-Holdback Sprocket Shaft Spring (2)
H-2702	Pad Roller Stud Set Screw (3)	P-2217	Sound Sprocket Pad Roller Arm
H-3203	Pal Roller Arm Adjusting Screw Lock Nut (2)	P-2219	Spring Guide Pivot (2)
H-3204	Shaft Retaining Nut (2)	P-2221	Holdback Sprocket Pad Roller Arm
H-3701	Pal Roller Arm Adjusting Screw (2)	P-2463	Spring Guide (2)
H-3801	Sprocket Shaft Key (3)	P-2597	Projector Drive Gear
P-1395	Allen Wrench—No. 8 Set Screw (For P-1432)*	P-2627	Takeup Drive Pulley
P-1432	Drive Gear Fastening Screw (3)	P-2710	Allen Wrench—No. 6 Set Screw (For H-2702)*
P-1442	Pad Roller Arm Spring Retainer (4)	P-2715	Drive Pinion (60 cycles)
P-2193	Gear Box Cover Gasket	P-2794	Allen Wrench—No. 8 Set Screw (For H-3701)*
P-2194	Sound Sprocket Shaft	P-2795	Sprocket Drive Gear (50 cycles) (2)
P-2195	Holdback Sprocket Shaft	P-2796	Drive Pinion (50 cycles)
P-2196	Sprocket Drive Gear (60 cycles) (2)	P-3055	Pad Roller Spring (2)
P-2199	Gear Box Ball Bearing (6)	P-3070	Oil Cup
P-2201	Film Side Bearing Outer Retainer (2)	P-3071	Oil Gauge Connecting Pipe
P-2202	Gear Side-Drive Bearing Outer Retainer (3)	P-3072	Oil Gauge Barrel
P-2203	Bearing Outer Retainer Gasket (6)	P-3073	Oil Drain Washer
P-2204	Film Side Oil Slinger (2)	P-3085	Pad Roller (3)
P-2205	Film Side Bearing Inner Retainer (2)	**P-3321	Holdback Sprocket
		**P-3322	Sound Sprocket

NOTE 1—G-2334 replaces P-2197, P-2198 and P-3085 with Inner Flanges. G-2334 consists of (3) P-3085 (for narrow or wide perforation film), P-3322, P-3321. Parts are shown to avoid duplication when ordering other replacement parts or kits. Not part of G-1962 or G-2125 and must be ordered separately.

\* Non-Component Item. Order Separately.

\*\* For projectors converted for use with narrow and wide perforation film.

\*\*\* For projectors not converted for use with narrow and wide perforation film.

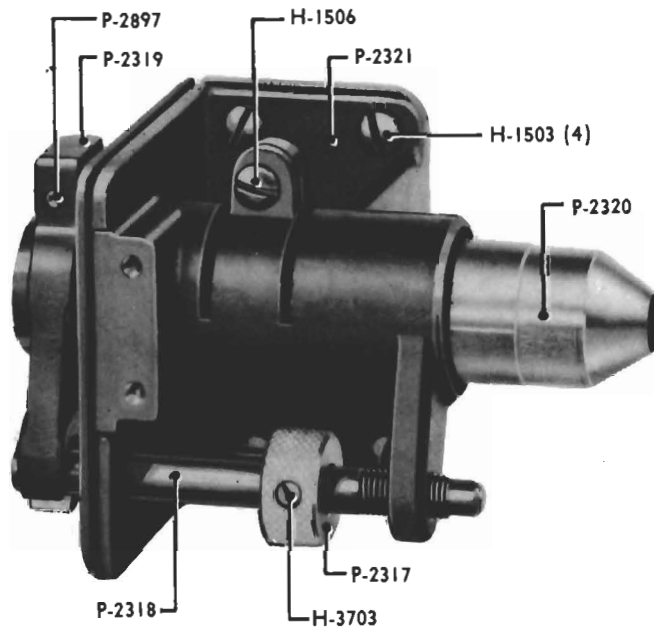

### G-1974 LENS ASSEMBLY

- H-1503 Lens Assembly Fastening Screw (4) \*
- H-1506 Lens Tube Clamping Screw
- H-3703 Lens Tube Adjusting Nut Set Screw
  
- P-2317 Lens Tube Adjusting Nut
- P-2318 Lens Tube Adjusting Screw
- P-2319 Lens Tube Adjusting Clamp
- P-2320 Lens Tube
- P-2321 Lens Tube Bracket
- P-2897 Lens Tube Adjusting Clamp Screw

\* Non-Component Item. Order Separately.

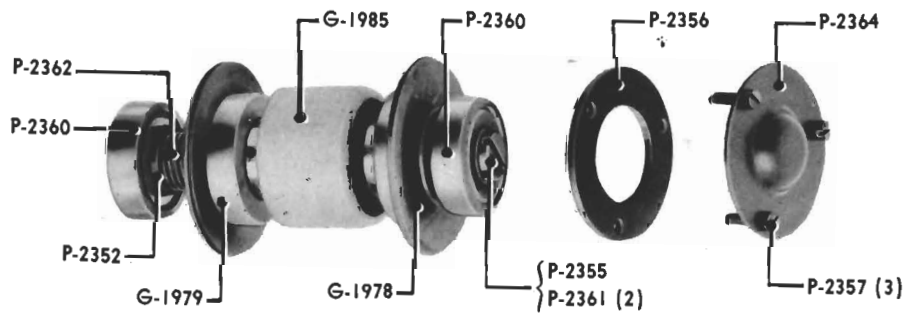
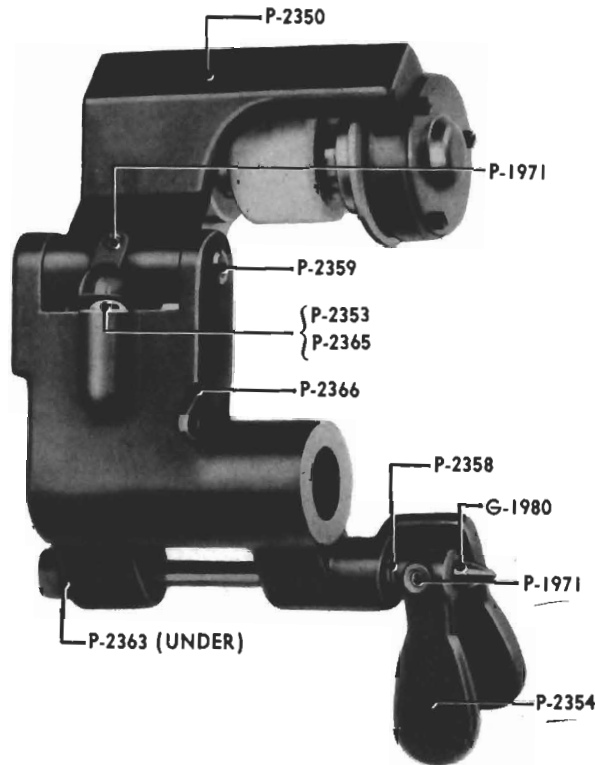

### G-1977 LATERAL GUIDE ROLLER

G-1978	Fixed Flanged Roller	P-2356	Bearing Retainer Plate
G-1979	Movable Flanged Roller	P-2357	Cover Fastening Screw (3)
G-1980	Operating Shaft and Stop Arm	P-2358	Operating Lever Spring
G-1985	Felt Roller	P-2359	Upper Bracket Pivot Pin
P-1971	Operating Lever-Pivot Set Screw (2)	P-2360	Ball Bearing (2)
P-2350	Upper Bracket	P-2361	Shaft Retaining Screw (2)
P-2352	Spring Retaining Washer	P-2362	Guide Roller Spring
P-2353	Upper Bracket Pressure Ball	P-2363	Operating Lever Shaft Spring
P-2354	Operating Lever	P-2364	Ball Bearing Cover
P-2355	Guide Roller Shaft	P-2365	Upper Bracket Pressure Spring
		P-2366	Lower Bracket
		P-2726	Bristle Wrench—No. 6 (For P-1971) *

\* Non-Component Item. Order Separately.



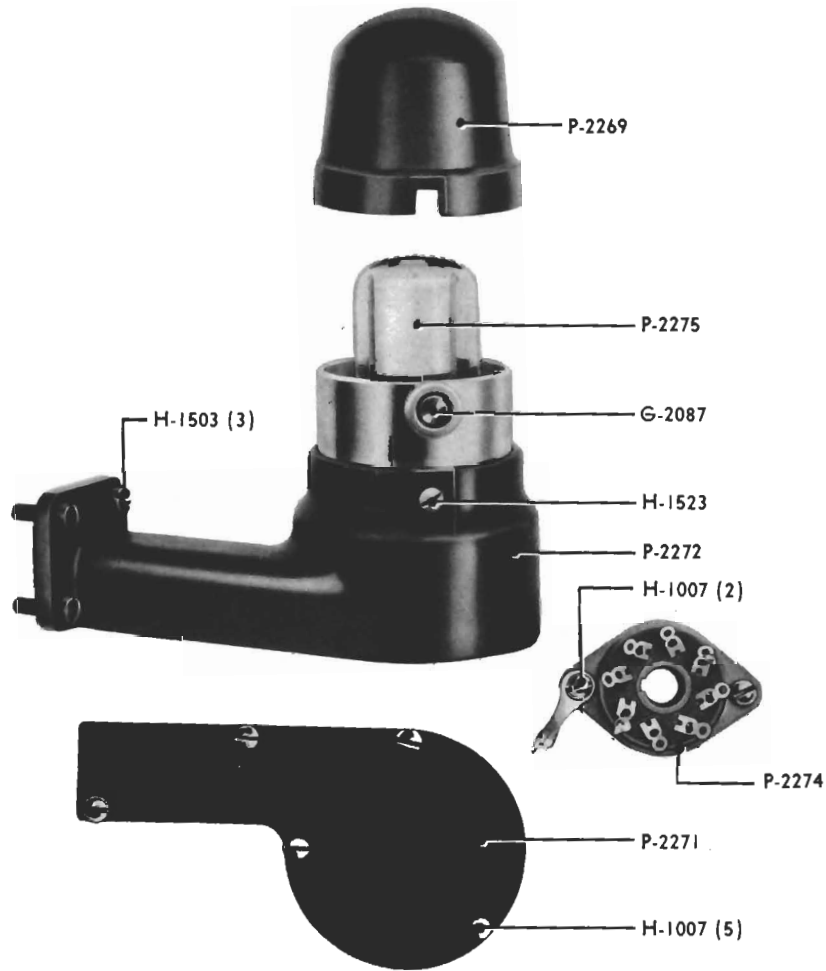

### G-1981 PHOTO CELL BRACKET

G-2087	Shield Clamping Screw and Sleeve	P-2269	Photo Cell Shield
H-1007	Cover Plate-Socket Fastening Screw (7)	P-2271	Cover Plate
H-1503	Bracket Fastening Screw (3)	P-2272	Bracket
H-1523	Shield Fastening Screw	P-2274	Photo Cell Socket
		P-2275	Photo Cell, No. 930 *

\* Non-Component Item. Order Separately.

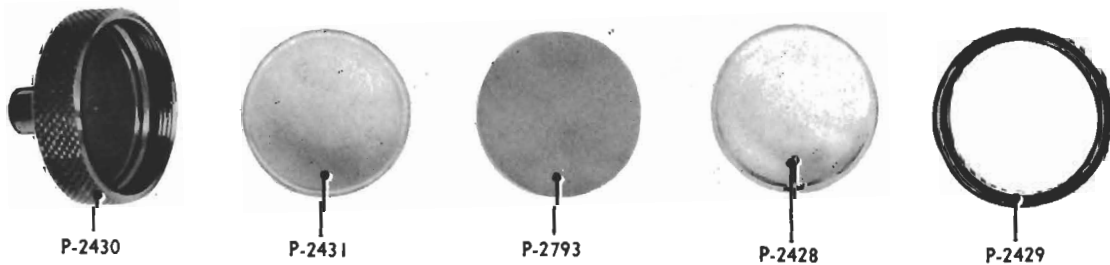

### G-1982 REFLECTOR LENS

P-2428	Lens Mirror	P-2431	Lens Spring
P-2429	Lens Ring	P-2793	Lens Gasket
P-2430	Lens Holder		

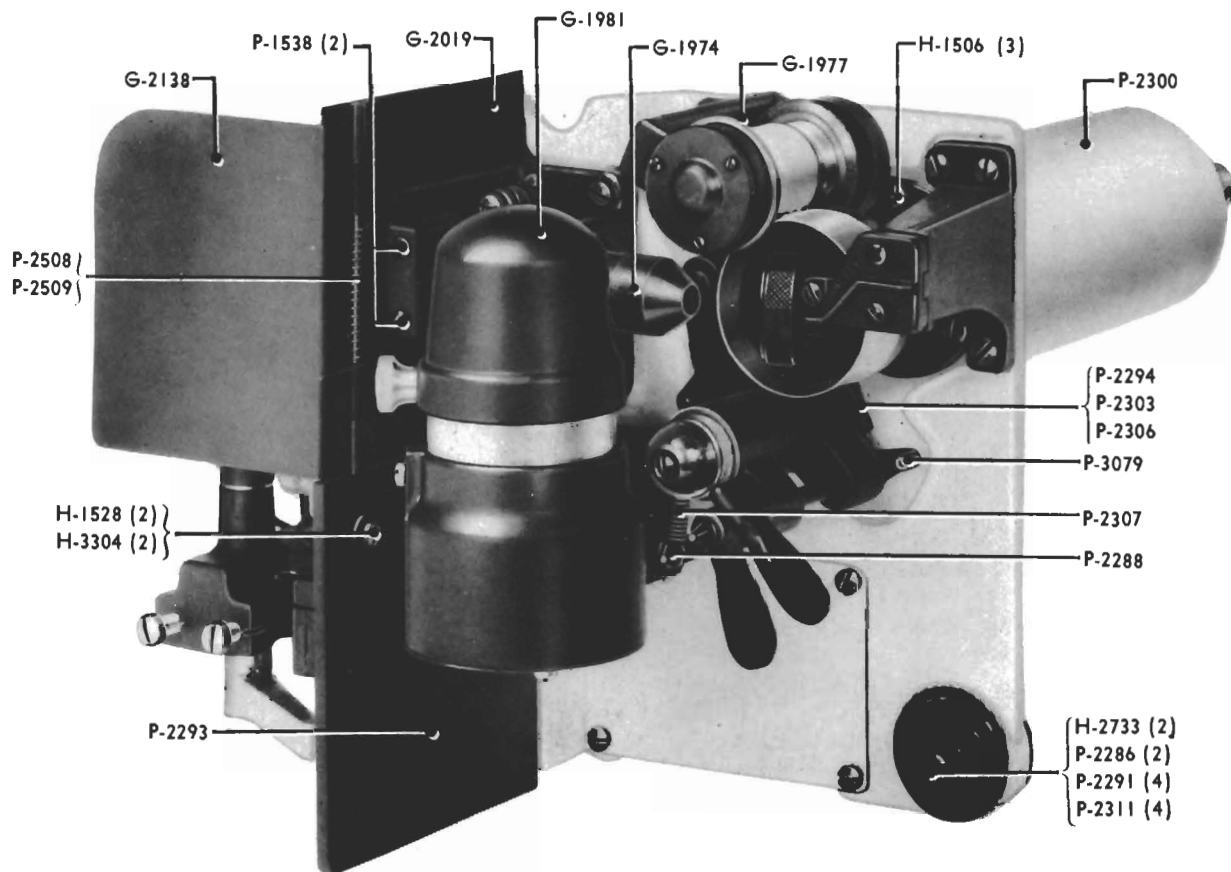

G-1983 SOUND BRACKET (Indoor, SH-1007, SH-1008)

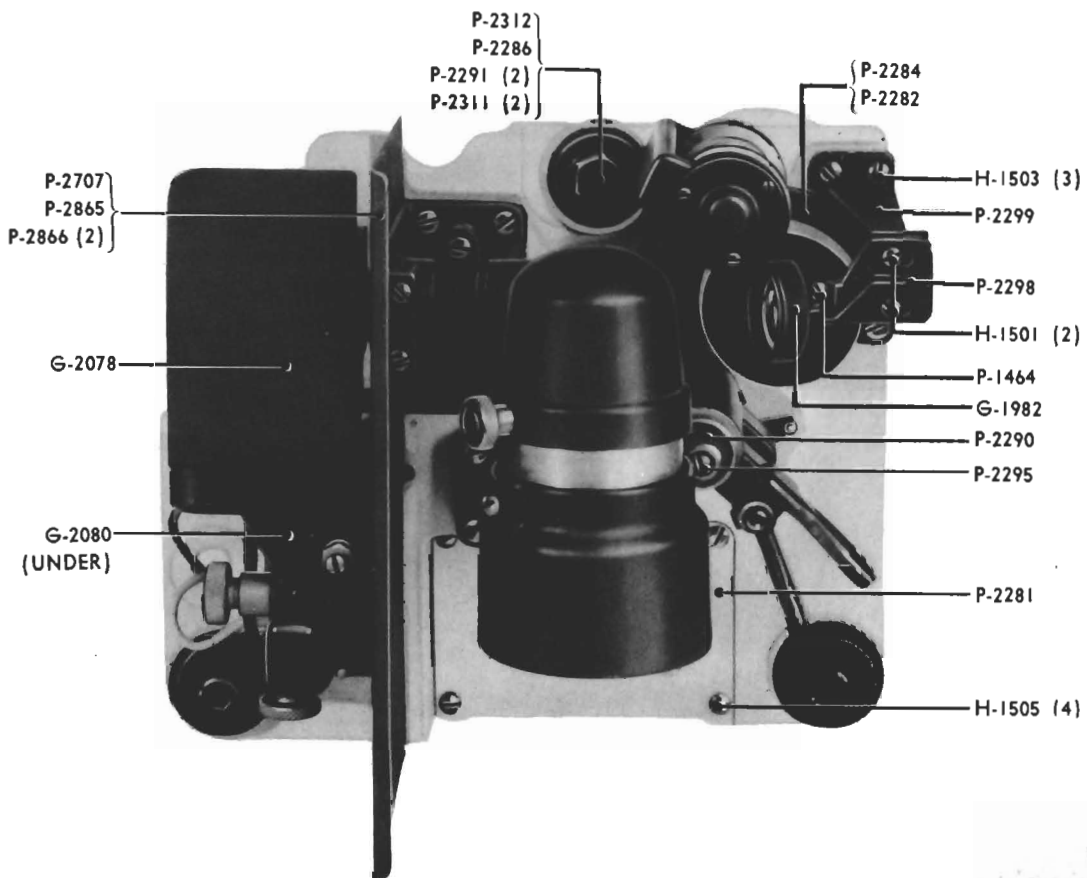

G-2141 SOUND BRACKET  
(Drive-In, SH-1012, SH-1013; Indoor and Drive-In, SH-1020, SH-1021)

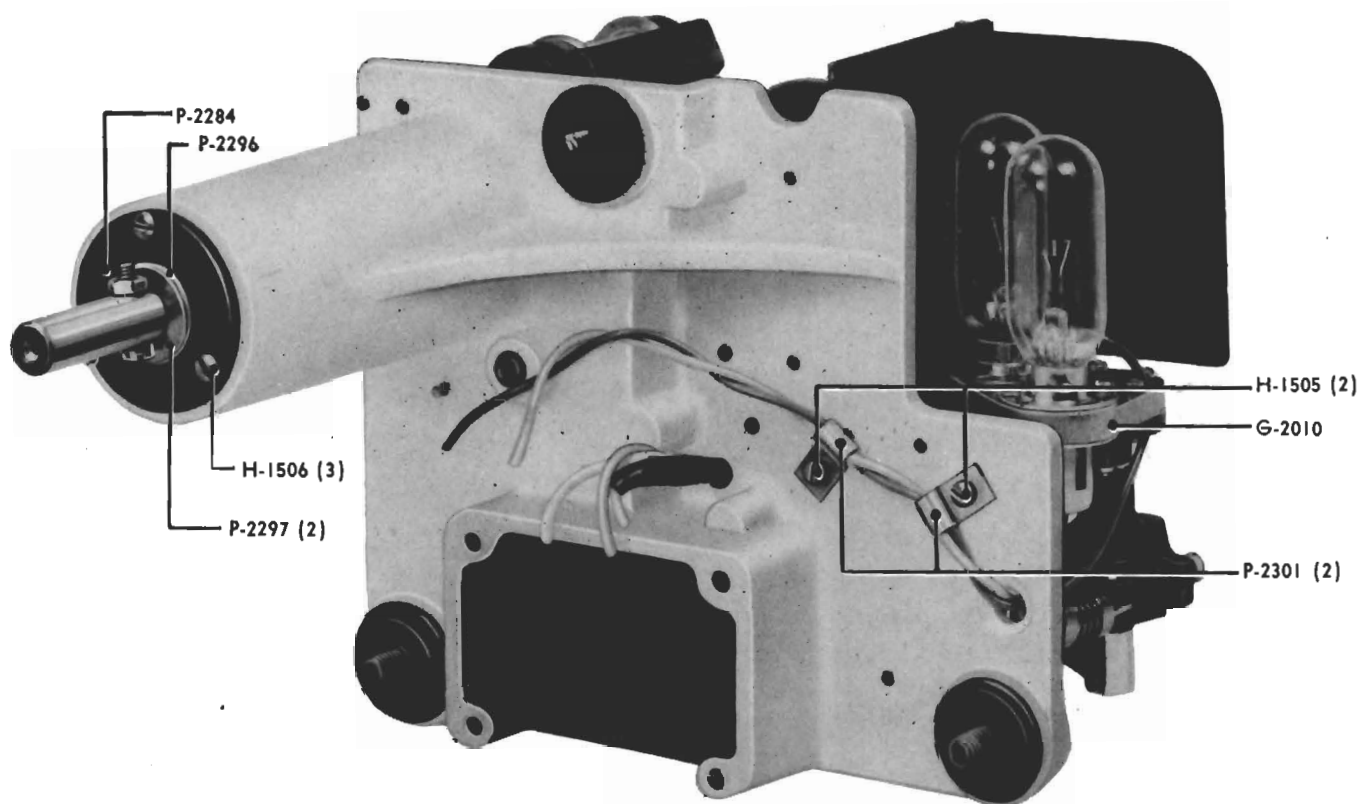

G-1983 SOUND BRACKET (Indoor, SH-1007, SH-1008)

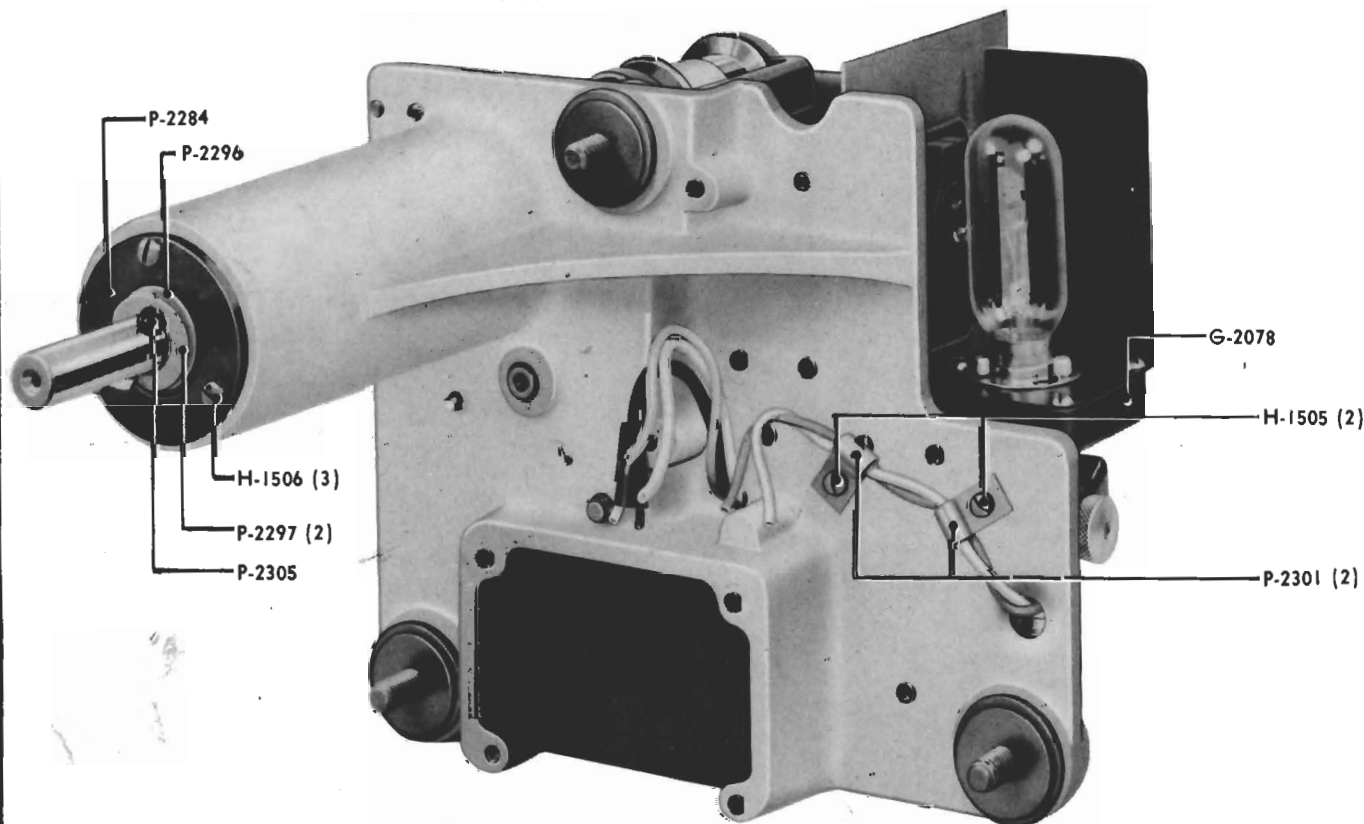

G-2141 SOUND BRACKET (Drive-In, SH-1012, SH-1013);  
Indoor and Drive-In, SH-1020, SH-1021

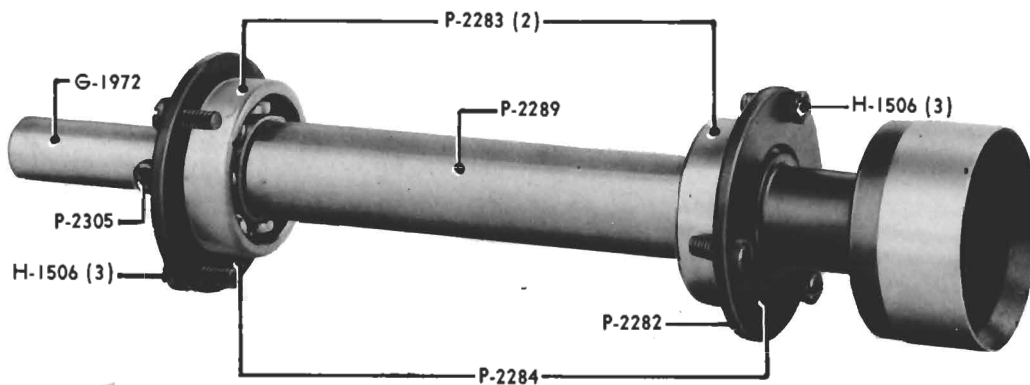

**G-1983 SOUND BRACKET (Indoor, SH-1007, SH-1008)**  
**G-2141 SOUND BRACKET (Drive-In, SH-1012, SH-1013)**  
**Indoor and Drive-In, SH-1020, SH-1021)**

G-1972	Drum Shaft	P-2284	Stabilizer Drum Bearing Retainer (2)
G-1974	Lens Assembly (Parts shown on page 6-4)	P-2286	Sound Bracket Spacer (3) *
G-1977	Lateral Guide Roller (Parts shown on page 6-5)	P-2288	Lateral Guide Roller Spring Stud
G-1981	Photo Cell Bracket (Parts shown on page 6-6)	P-2289	Drum Shaft Bearing Spacer
G-1982	Reflector Lens (Parts shown on page 6-6)	P-2290	Lateral Guide Roller Adjusting Nut
G-2010	Exciter Lamp Bracket (G-1983) (Parts shown on page 6-11)	→ P-2291	Sound Bracket Resilient Bushing (6) *
G-2019	Upper Partition Plate (G-1983)	P-2293	Lower Partition Plate (G-1983)
G-2078	Exciter Lamp Bracket (G-2141) (Parts shown on page 6-13)	P-2294	Lateral Guide Roller Mounting Stud
G-2080	Exciter Lamp Base (G-2141) (Parts shown page 6-13)	P-2295	Lateral Guide Roller Adjusting Nut Locking Screw
G-2138	Exciter Lamp Shield (G-1983)	P-2296	Drum Shaft Collar
H-1501	Reflector Lens Adjusting Bracket Fastening Screw (2)	P-2297	Drum Shaft Spring Washer (2)
H-1503	Reflector Lens Mounting Bracket Fastening Screw (3)	P-2298	Reflector Lens Adjusting Bracket
H-1505	Cover Plate-Cable Clamp Fastening Screw (6)	P-2299	Reflector Lens Mounting Bracket
H-1506	Drum Shaft Bearing Retainer Fastening Screw (6)	P-2300	Sound Bracket
H-1528	Partition Plate Fastening Screw (G-1983) (2)	P-2301	Cable Clamp (2) *
H-2733	Sound Bracket Lower Fastening Screw (2) *	P-2303	Lateral Guide Roller Pressure Spring
H-3304	Partition Plate Washer (G-1983) (2)	P-2305	Stabilizer Drum Fastening Screw
P-1464	Reflector Lens Clamping Screw	P-2306	Lateral Guide Roller Pressure Spring Washer
P-1538	Partition Plate and Shield Fastening Screw (2)	P-2307	Lateral Guide Roller Spring
P-2281	Terminal Strip Cover Plate	P-2311	Sound Bracket Washer (6) *
P-2282	Stabilizer Drum Bearing Retainer Gasket	P-2312	Sound Bracket Upper Fastening Screw *
P-2283	Drum Shaft Ball Bearing (2)	P-2508	Partition Plate Hinge Pin (G-1983)
		P-2509	Partition Plate Hinge Spring (G-1983)
		P-2707	Partition Plate (G-2141)
		P-2711	Allen Wrench—No. 10 Cap Screw (For H-2733) *
		P-2865	Partition Plate Extension (G-2141)
		P-2866	Partition Plate Extension Fastening Screws (G-2141) (2)
		P-3079	Lateral Guide Roller Stop Pin

\* Non-Component Item. Order Separately.

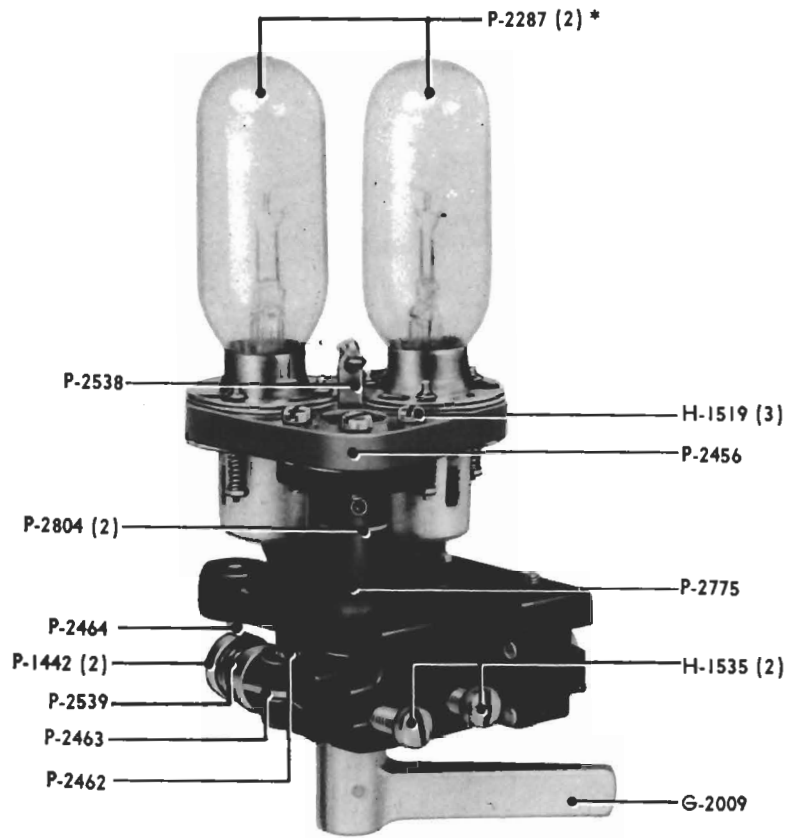

\* NON-COMPONENT ITEM.  
ORDER SEPARATELY.

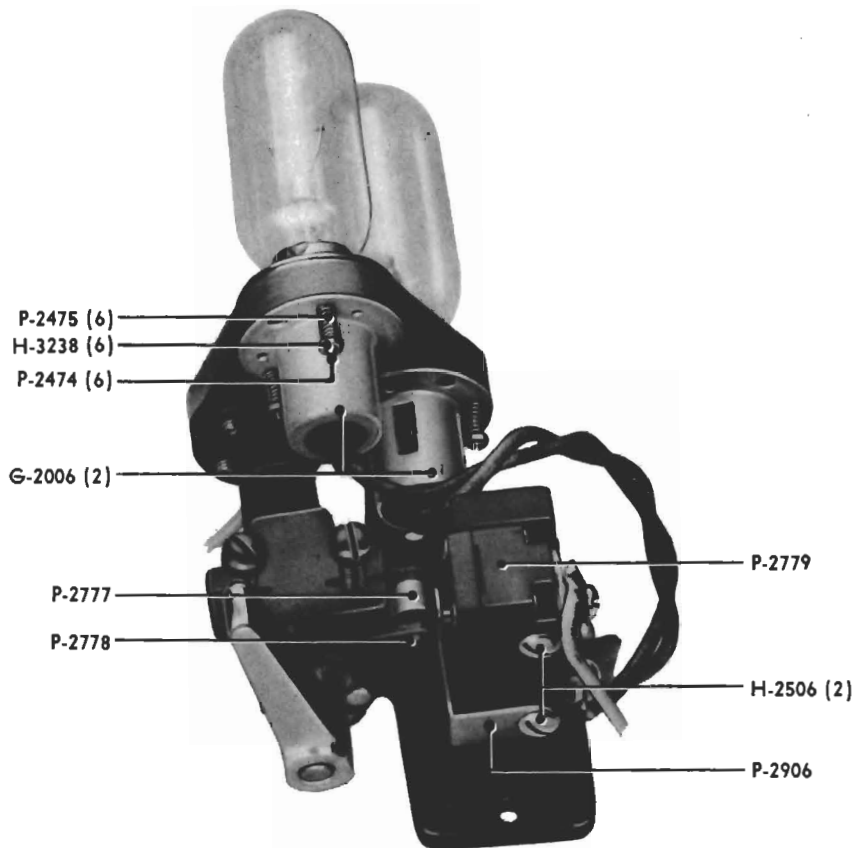

G-2010 DUAL EXCITER LAMP BRACKET

## G-2010 DUAL EXCITER LAMP BRACKET

G-2006	Exciter Lamp Socket (2)
G-2009	Shaft, Lever and Brackets
H-1503	Bracket Fastening Screw (3) *
H-1519	Mounting Plate Fastening Screw (3)
H-1535	Exciter Lamp Adjusting Screw (2)
H-2506	Switch Fastening Screw (2)
H-3238	Socket Pin Retaining Nut (6)
P-1442	Spring Retainer (2)
P-2287	Exciter Lamp, 9 volts, 4 amp. (2) *
P-2456	Socket Mounting Plate
P-2462	Spring Guide Pivot Pin
P-2463	Spring Guide
P-2464	Spring Guide Retainer Stud
P-2474	Socket Mounting Screw Pin (6)
P-2475	Socket Pressure Spring (6)
P-2538	Socket Retaining Plate
P-2539	Spring
P-2775	Main Bracket
P-2777	Roller
P-2778	Roller Pivot
P-2779	Switch, SPDT
P-2804	Bearing Washer (2)
P-2906	Switch Operating Spring

—  
\* Non-Component Item. Order Separately.

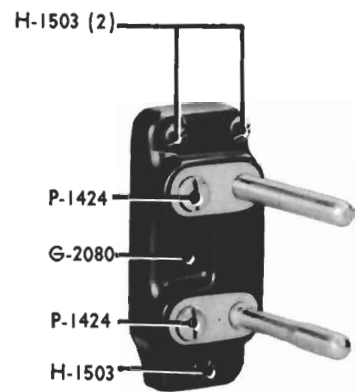
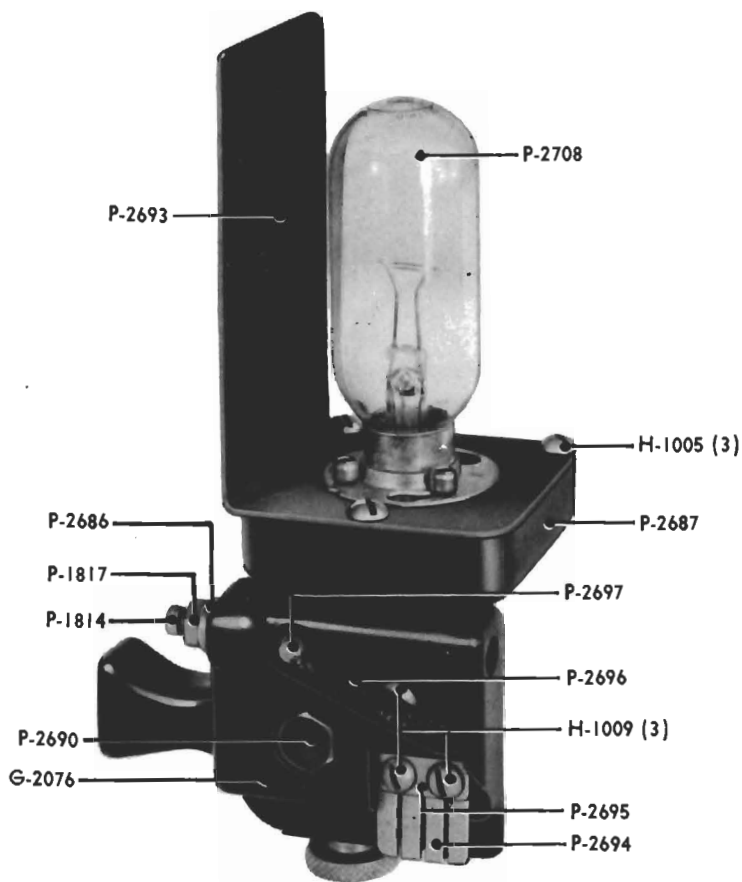
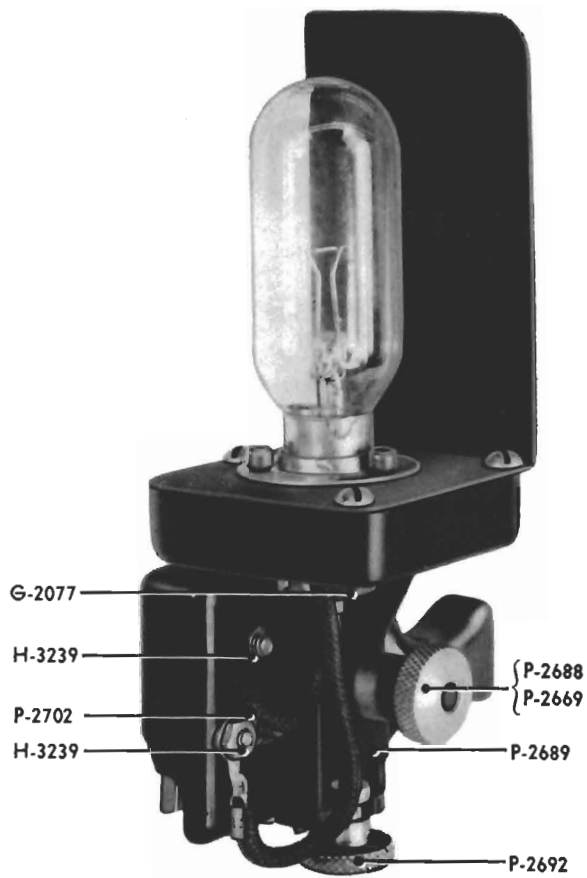

G-2078 EXCITER LAMP BRACKET

G-2080 EXCITER LAMP BASE

## G-2078 EXCITER LAMP BRACKET

G-2076 Lower Bracket

*sf* → G-2077 Lamp Socket

H-1005 Shield Fastening Screw (3)

H-1009 Contact Spring Fastening Screw (3)

H-3239 Contact-Pressure Spring Fastening Nut (2)

*P-2698 CENTER BULB CONTACT NOT AVAILABLE*

P-1814 Lateral Adjusting Screw

P-1817 Lateral Adjusting Screw Lock Nut

P-2669 Vertical Adjustment Locking Knob Spring

P-2686 Lateral Adjusting Screw Bushing

P-2687 Upper Bracket

P-2688 Vertical Adjustment Locking Knob

P-2689 Vertical Adjustment Locking Bar

P-2690 Vertical Adjustment Locking Stud

P-2692 Vertical Adjusting Screw

P-2693 Exciter Lamp Shield

P-2694 Contact Spring

P-2695 Contact Spring Retainer

P-2696 Contact Pressure Spring

P-2697 Contact

P-2702 Contact Spring Fastening Plate

P-2708 Exciter Lamp, 10 volts, 7.5 amp.\*

*→ P-2698 Exciter Lamp Socket & Wire Assy.*

## G-2080 EXCITER LAMP BASE

H-1503 Mounting Screw (3) \*

P-1424 Terminal Screw (2)

\* Non-Component Item. Order Separately.



# SECTION VII

## NUMERICAL LIST OF PARTS

Part No.	Page No.	Part No.	Page No.	Part No.	Page No.
G-1854	5-0, 5-4	G-2076	6-12	G-2363	5-15
G-1927	2-4	G-2077	6-12	G-2364	5-11
G-1928	2-8, 2-9, 2-14, 2-15, 2-16, 2-20, 2-21, 2-24	G-2078	6-7, 6-8, 6-12	G-2365	5-11
G-1932	2-8, 2-9	G-2080	6-7, 6-12	G-2366	1-8
G-1933	2-8, 2-9, 2-17	G-2087	6-6	G-2372	1-8
G-1940	1-1	G-2096	2-12	G-2373	2-28
G-1941	2-13	G-2097	2-10	G-2376	2-30
G-1946	2-6	G-2113	3-2	G-2378	2-28
G-1948	2-6	G-2114	2-18, 3-2	G-2379	2-31
G-1958	6-1	G-2118	2-13	G-2380	2-31
G-1959	6-1, 6-2	G-2119	1-1	G-2381	4-8
G-1962	5-0, 5-4, 6-1	G-2121	5-2	G-2382	4-8
G-1966	1-0	G-2124	5-2	G-2384	5-16, 5-17
G-1971	2-0, 2-2	G-2125	5-0, 5-4, 6-1	G-2385	5-17
G-1972	6-9	G-2127	5-2	G-2387	4-8
G-1973	2-13	G-2138	6-7	G-2388	4-6
G-1974	6-4, 6-7	G-2141	5-0, 5-4, 6-7	G-2392	2-26
G-1976	5-2	G-2145	2-15	G-2394	2-26
G-1977	6-5, 6-7	G-2146	2-15	G-2397	5-8
G-1978	6-5	G-2165	2-13, 2-40	G-2399	1-10
G-1979	6-5	G-2166	2-16	G-2406	2-26
G-1980	6-5	G-2167	2-16	G-2407	5-16
G-1981	6-6, 6-7	G-2181	5-4	G-2408	2-32, 4-10
G-1982	6-6, 6-7	G-2187	5-5	G-2422	1-11
G-1983	5-0, 6-7	G-2188	2-0	G-2425	1-11
G-1984	2-22, 5-0	G-2202	3-8	G-2426	1-13, 1-15
G-1985	6-5	G-2203	3-8	G-2432	1-13, 1-15
G-1986	3-0	G-2204	3-10	G-2439	1-13, 1-15
G-1987	3-0	G-2207	3-10	G-2440	1-13
G-1988	3-0	G-2270	2-20	G-2455	1-15
G-1991	2-4	G-2273	1-3	G-2457	1-15
G-1993	5-0, 5-4	G-2274	1-2, 1-4	G-2458	1-15
G-1994	5-0, 5-4	G-2278	2-18, 2-34	G-2459	3-6
G-1998	5-0, 5-4, 5-8	G-2286	1-3, 1-5	G-2462	2-32
G-2000	2-8	G-2287	1-6	G-2480	2-37
G-2001	2-9	G-2290	2-20	G-2482	2-37, 2-38
G-2002	5-0, 5-5	G-2292	1-3	G-2484	2-37, 2-38
G-2006	6-10	G-2296	3-4	G-2489	2-37, 2-38
G-2009	6-10	G-2298	1-5	G-2491	2-37, 2-38
G-2010	6-8, 6-10	G-2301	3-4	G-2492	2-36
G-2019	6-7	G-2311	2-21	G-2495	2-40
G-2037	4-2	G-2334	6-3	G-2496	2-40
G-2038	4-2	G-2349	2-22	G-2499	2-40
G-2049	2-0	G-2351	2-24	G-2504	2-40
G-2052	2-2	G-2352	2-24		
G-2054	2-22, 5-0	G-2354	5-8		
G-2055	4-2	G-2355	5-11	H-1001	3-6
G-2056	4-4	G-2357	5-8	H-1005	6-12
G-2058	2-10	G-2358	5-8	H-1007	6-6
G-2065	2-18, 2-34, 3-2	G-2359	5-12, 5-13	H-1009	6-12
		G-2360	5-14	H-1015	1-6, 2-40
		G-2361	5-14	H-1020	1-8, 3-6
		G-2362	5-15	H-1032	4-2

<i>Part No.</i>	<i>Page No.</i>
H-1033	4-2
H-1052	2-22
H-1053	3-8, 3-10
H-1054	4-10
H-1071	5-12, 5-13
H-1501	6-1, 6-2, 6-7
H-1502	6-1
H-1503	5-16, 5-17, 6-1, 6-4, 6-6, 6-7, 6-10, 6-12
H-1505	5-0, 5-4, 5-5, 6-7, 6-8
H-1506	5-16, 5-17, 6-4, 6-7, 6-8, 6-9
H-1507	5-0, 5-5, 5-16, 5-17
H-1511	5-0, 5-4
H-1512	5-0, 5-4, 5-12, 5-13
H-1513	6-1
H-1519	6-10
H-1523	6-6
H-1526	4-2
H-1528	6-7
H-1532	1-0, 1-2, 1-4, 1-10, 2-12
H-1535	6-10
H-1538	6-1
H-1541	5-8
H-1542	5-12, 5-13
H-1543	5-8
H-1545	5-16
H-2001	2-40, 3-6, 4-6, 6-1
H-2003	5-2
H-2004	5-2
H-2010	3-8, 3-10
H-2025	3-0
H-2027	3-8
H-2028	3-8
H-2029	3-8, 3-10
H-2030	3-8, 3-10
H-2031	3-8, 3-10
H-2040	2-24
H-2502	5-2
H-2505	5-0
H-2506	6-10
H-2515	5-17
H-2603	5-2
H-2619	5-0, 5-4
H-2646	5-0, 5-5
H-2647	5-0, 5-5
H-2648	2-8, 2-21, 2-24
H-2653	2-0, 2-2, 2-18, 2-34, 2-37, 3-2, 4-5
H-2659	5-8
H-2702	5-8, 6-1

<i>Part No.</i>	<i>Page No.</i>
H-2709	5-0, 5-4, 5-5, 5-12, 5-13
H-2714	2-6, 2-7, 2-10, 4-8
H-2715	2-0, 2-4, 2-18, 2-26, 2-28, 2-34, 2-36, 2-37, 3-2, 4-4
H-2716	1-1, 1-3, 1-5, 1-11, 1-12, 1-13, 1-14, 1-15, 2-0, 2-2, 2-4, 2-13, 2-26, 2-32, 2-37, 3-0, 4-4, 4-6
H-2717	2-0, 2-2, 2-37
H-2718	1-13, 1-15, 2-0, 2-2, 2-9, 2-11, 2-15, 2-16, 2-18, 2-29, 2-34, 2-40, 3-2, 3-4, 4-4, 4-5
H-2719	4-4
H-2721	2-0, 2-2
H-2722	2-9, 2-15, 2-16
H-2723	2-8, 2-9, 2-14, 2-15, 2-16, 2-17, 2-20, 2-21, 2-24, 2-40
H-2724	2-8, 2-9, 2-14, 2-15, 2-16, 2-17, 2-20, 2-21, 2-24, 2-40, 3-4, 4-4, 4-6, 4-8
H-2725	2-31
H-2728	2-4, 2-26, 3-4
H-2732	5-8
H-2733	6-7
H-2738	3-4
H-2741	2-26, 2-28, 2-29
H-2747	1-13, 1-15, 2-36
H-3006	2-22
H-3051	1-2, 1-4, 1-10, 2-0, 2-2, 2-4, 2-12, 2-13, 2-18, 2-26, 2-28, 2-34, 2-37, 3-2, 4-4, 4-6, 4-8, 5-12
H-3052	5-0, 5-4, 5-8
H-3053	4-1
H-3054	5-16, 5-17
H-3101	2-6, 2-10, 2-22, 3-0, 5-0, 5-4, 5-5, 5-8
H-3104	2-30, 3-8, 3-10
H-3202	1-0, 1-3, 1-5, 1-11, 2-13, 2-24, 2-31, 3-8, 3-10, 4-10

<i>Part No.</i>	<i>Page No.</i>
H-3203	6-1
H-3204	6-1
H-3213	2-8, 2-21, 2-24, 4-4, 4-6
H-3226	1-1, 1-3, 1-5, 1-11, 1-13, 1-15, 2-0, 2-2, 2-4, 2-6, 2-7, 2-10, 2-13, 2-18, 2-26, 2-28, 2-29, 2-32, 2-34, 3-2, 3-4, 3-6, 4-4, 4-8
H-3238	6-10
H-3239	1-8, 6-12
H-3240	1-13, 1-15, 2-0, 2-2, 2-9, 2-11, 2-15, 2-16, 2-18, 2-22, 2-34, 2-40, 3-2, 3-4, 3-6, 4-4, 4-5
H-3241	2-0, 2-2
H-3242	4-5
H-3243	1-12, 1-14, 2-0, 2-0, 2-2, 2-4, 2-9, 2-13, 2-15, 2-16, 2-18, 2-24, 2-34, 2-36, 2-40, 3-2, 3-6, 3-8, 3-10
H-3244	1-6, 1-8, 2-0, 2-2, 2-18, 2-34, 2-36, 2-37, 3-2, 4-4, 4-6
H-3247	2-0, 2-2, 2-18, 2-34, 2-36, 3-2, 4-5, 4-6
H-3248	3-0
H-3253	1-6, 2-36, 2-37, 2-40, 4-6
H-3255	2-0, 2-2, 2-6, 2-8, 2-9, 2-10, 2-16, 2-18, 2-20, 2-21, 2-24, 2-34, 2-37, 3-2, 4-5
H-3256	3-10
H-3261	5-11
H-3265	2-37, 5-8
H-3268	5-12
H-3304	4-2, 5-0, 5-4, 6-7
H-3311	2-18, 2-34, 3-2
H-3312	4-2
H-3324	2-40, 3-4, 3-6, 3-8, 3-10, 4-10, 5-16, 5-17
H-3329	5-0, 5-4, 5-8, 5-10

<i>Part No.</i>	<i>Page No.</i>
H-3333	5-11
H-3337	5-14
H-3338	5-11, 5-14
H-3339	5-15
H-3340	2-28
H-3341	2-26, 5-8, 5-16, 5-17
H-3342	5-8
H-3343	5-8
H-3405	1-13, 1-15, 2-0, 2-2, 2-36
H-3419	1-8, 2-9, 2-15, 2-16, 3-10, 4-2, 4-6
H-3420	4-2
H-3436	2-0, 2-2, 2-18, 2-34, 2-37, 3-2, 4-5
H-3437	4-2
H-3438	2-0
H-3439	4-5, 4-6
H-3440	2-4, 2-18, 2-34, 2-36, 3-2
H-3441	2-6, 2-7, 2-10, 4-6, 4-8
H-3442	1-1, 1-3, 1-5, 1-10, 2-13
H-3444	1-12, 1-14, 2-24, 3-8, 3-10
H-3445	1-13, 1-15, 2-31, 3-6, 3-8, 3-10, 4-10, 5-8
H-3446	2-37, 3-10
H-3448	1-12, 1-13, 1-14, 1-15, 2-26, 2-29, 2-32, 3-4, 3-6
H-3449	2-37
H-3450	3-4, 4-6, 4-8
H-3454	5-8, 5-16, 5-17
H-3501	2-37
H-3701	5-8, 6-1
H-3703	6-4
H-3704	5-0, 5-2
H-3713	5-2
H-3723	5-8
H-3801	5-2, 6-2
H-4901	1-6, 1-8, 1-12, 1-14
P-1004	1-12, 1-14, 2-3, 2-28, 2-33
P-1007	2-4
P-1010	2-1, 2-3
P-1013	2-28
P-1016	2-37
P-1053	2-0
P-1055	2-0, 2-2, 2-18, 3-2

<i>Part No.</i>	<i>Page No.</i>
P-1066	2-8, 2-9, 2-14, 2-15, 2-16, 2-17, 2-20, 2-21, 2-24, 2-40
P-1075	2-37
P-1076	2-29
P-1137	5-16
P-1145	1-0, 1-3, 1-5, 1-11, 2-0, 2-2, 2-9, 2-11, 2-13, 2-15, 2-16, 2-18, 2-24, 2-31, 2-34, 2-40, 3-0, 3-2, 3-4, 4-4, 4-5, 5-0
P-1146	2-8, 2-9, 2-14, 2-15, 2-16, 2-17, 2-20, 2-21, 2-24, 2-40, 4-2, 4-4
P-1200	1-8
P-1238	2-0, 2-2, 2-6, 2-8, 2-9, 2-10, 2-16, 2-18, 2-20, 2-21, 2-24, 2-34, 2-37, 3-2, 4-5
P-1257	1-0, 1-3, 1-5, 1-11, 2-13, 2-31, 4-2
P-1258	4-2
P-1259	4-2
P-1266	2-7, 2-11, 4-2, 4-8, 5-0, 5-4, 5-8
P-1267	2-6, 2-10, 4-2, 4-8, 5-0, 5-4, 5-8
P-1275	4-2
P-1276	4-2
P-1278	1-1, 1-3, 1-5, 1-6, 1-11, 2-0, 2-2, 2-4, 2-13, 2-18, 2-28, 2-29, 2-34, 2-36, 2-37, 2-40, 3-0, 3-2, 4-2, 4-4
P-1279	4-2
P-1280	2-0, 2-2, 2-9, 2-13, 2-15, 2-16, 2-24, 2-36, 2-37, 2-40, 3-6, 3-8, 3-10, 4-4
P-1281	4-2
P-1314	2-24
P-1317	5-17
P-1391	1-8
P-1395	5-3, 5-4, 5-6, 6-3

<i>Part No.</i>	<i>Page No.</i>
P-1424	6-12
P-1432	6-1
P-1442	5-8, 6-1, 6-10
P-1464	6-7
P-1527	5-10
P-1538	6-7
P-1652	5-8
P-1653	5-8
P-1703	5-8, 5-11
P-1734	4-2
P-1736	5-8
P-1757	5-14
P-1764	1-0, 1-3, 1-5, 1-11, 2-13, 2-31
P-1778	5-11
P-1812	5-8
P-1814	6-12
P-1817	6-12
P-1828	5-11
P-1859	1-1, 1-3, 1-5, 1-11, 2-9, 2-13, 2-15, 2-16, 2-40, 3-6, 4-4
P-1895	5-2
P-1917	3-0, 3-8, 3-10
P-1918	5-16, 5-17
P-1932	4-2
P-1962	5-11
P-1963	5-8, 5-14
P-1964	5-8
P-1971	6-5
P-2038	2-0, 2-3, 2-38
P-2039	2-3
P-2040	1-13, 1-15, 2-3, 2-26, 2-32, 2-38, 2-40
P-2042	2-13, 2-38, 2-40
P-2043	2-3
P-2044	2-3
P-2045	2-1, 2-3, 2-18, 2-38, 3-2
P-2046	2-0, 2-3, 2-28, 2-38
P-2047	2-3, 2-4, 2-18, 3-2, 5-5
P-2048	1-8, 1-15, 2-1, 2-3, 2-4, 2-13, 2-28, 2-38, 2-40
P-2050	2-3
P-2051	1-3, 2-1, 2-3, 2-4, 2-38
P-2052	2-4
P-2053	2-4
P-2054	2-4
P-2055	2-4, 2-28
P-2057	2-4

Part No.	Page No.
P-2058	2-0, 2-1, 2-2, 2-3, 2-4, 2-13, 2-18, 2-34, 2-37, 3-2
P-2061	2-1, 2-3
P-2062	2-4
P-2063	2-4, 2-26, 2-28, 2-32, 4-10
P-2064	2-4, 2-26, 2-28
P-2066	2-0, 2-2
P-2067	2-1
P-2069	1-15, 2-1, 2-3
P-2070	2-1
P-2071	2-1
P-2072	2-1
P-2073	2-1
P-2074	2-1, 2-4, 2-28
P-2075	1-3, 2-1, 2-12, 2-26, 2-28, 2-41
P-2076	2-1, 2-9, 2-15, 2-16, 2-20, 2-21, 2-24
P-2077	2-1
P-2079	2-2
P-2080	2-2
P-2081	2-2
P-2082	2-0, 2-2
P-2083	2-2
P-2084	2-2, 2-36, 4-6
P-2085	2-0, 2-2, 2-18, 3-2
P-2086	2-2
P-2087	2-0, 2-2
P-2088	2-0, 2-2
P-2089	2-0, 2-2, 2-37, 4-4, 4-6
P-2090	2-0, 2-2, 2-18, 2-34, 2-36, 3-2, 4-5, 4-6
P-2091	2-0, 2-2
P-2092	2-0, 2-2, 2-13
P-2093	2-0
P-2094	2-0
P-2095	2-0
P-2096	2-0
P-2097	2-0
P-2098	2-0
P-2099	1-1, 1-2, 1-3, 1-5, 1-8, 1-15, 2-0, 2-12, 2-13, 2-29, 2-37, 2-41, 3-4, 3-6
P-2100	2-0
P-2101	2-0
P-2106	2-18, 3-2
P-2107	4-4
P-2108	3-2

Part No.	Page No.
P-2110	2-0, 2-2, 2-13
P-2113	3-2
P-2114	4-5
P-2117	2-4
P-2118	2-4
P-2120	2-18, 3-2
P-2121	2-4
P-2122	2-13, 2-31, 4-8
P-2123	2-18, 3-2
P-2124	2-18, 3-2
P-2125	1-12, 1-14, 2-3, 2-18, 2-33, 3-2, 3-4
P-2126	2-18, 2-28, 3-2
P-2127	2-18, 2-28, 3-2
P-2128	2-18, 3-2
P-2129	2-2, 2-18, 3-2
P-2130	2-18, 2-36, 3-2, 4-6
P-2137	2-0, 2-2
P-2139	4-5
P-2140	4-4
P-2141	4-4
P-2142	4-4
P-2143	4-4
P-2145	4-5
P-2146	4-5
P-2155	2-6, 2-9, 2-10, 2-16, 2-20
P-2156	2-6, 2-9, 2-10, 2-16, 2-20
P-2160	2-6, 2-9, 2-10, 2-16, 2-20
P-2161	2-6, 2-9, 2-10, 2-16, 2-20, 4-5
P-2162	2-0, 2-2, 2-18, 2-34, 2-37, 3-2, 4-5
P-2163	2-6, 2-9, 2-10, 2-16, 2-20
P-2164	2-6, 2-9, 2-10, 2-16, 2-20
P-2165	2-6, 2-9, 2-10, 2-16, 2-20
P-2166	2-0, 2-2, 2-18, 2-34, 2-37, 3-2, 4-5
P-2167	2-6, 2-9, 2-10, 2-16, 2-20
P-2174	2-6
P-2175	2-4, 2-26
P-2176	2-0, 2-2, 2-18, 2-28, 2-29, 2-36, 3-2, 4-6
P-2177	2-9, 2-15, 2-16
P-2179	2-9, 2-15, 2-16, 2-40

Part No.	Page No.
P-2180	2-9, 2-15, 2-16
P-2182	2-9, 2-15, 2-16
P-2183	1-12, 1-14, 2-0, 2-2, 2-9, 2-15, 2-16, 2-18, 2-24, 2-34, 2-36, 2-40, 3-2, 3-6, 3-8, 3-10
P-2185	2-9, 2-15, 2-16, 2-40, 3-6
P-2187	2-9, 2-15, 2-16
P-2193	6-2
P-2194	6-2
P-2195	6-2
P-2196	6-2
P-2199	6-2
P-2201	6-1
P-2202	6-1
P-2203	6-1, 6-2
P-2204	6-2
P-2205	6-2
P-2206	6-1
P-2207	6-1
P-2208	6-1
P-2209	6-1
P-2210	6-1
P-2211	6-1
P-2213	6-1, 6-2
P-2214	6-1
P-2215	5-8, 6-1
P-2217	6-1
P-2219	6-1
P-2221	6-1
P-2222	3-2
P-2223	3-2
P-2226	3-2
P-2227	2-18, 2-34, 3-2
P-2228	2-2, 2-18, 2-34, 3-2
P-2229	2-18, 2-34, 3-2
P-2230	4-4
P-2231	5-0
P-2234	5-0, 5-4
P-2236	2-6, 2-9, 2-10, 2-16, 2-20
P-2237	2-0, 2-37, 4-4
P-2247	2-10
P-2257	2-2, 2-36, 4-6
P-2264	1-1, 1-3, 1-5, 1-6, 1-8, 1-11, 2-12
P-2269	6-6
P-2271	6-6
P-2272	6-6
P-2274	6-6
P-2275	6-6

Part No.	Page No.
P-2276	1-1, 1-8, 2-12, 2-40
P-2277	4-4
P-2278	2-6, 2-9, 2-10, 2-16, 2-20
P-2279	2-6, 2-9, 2-16, 2-20
P-2281	6-7
P-2282	6-7, 6-9
P-2283	6-9
P-2284	6-7, 6-8, 6-9
P-2285	5-0, 5-5
P-2286	6-7
P-2287	6-10
P-2288	6-7
P-2289	6-9
P-2290	6-7
P-2291	6-7
P-2293	6-7
P-2294	6-7
P-2295	6-7
P-2296	6-8
P-2297	5-15, 6-8
P-2298	6-7
P-2299	6-7
P-2300	6-7
P-2301	6-8
P-2303	6-7
P-2305	6-8, 6-9
P-2306	6-7
P-2307	6-7
P-2311	6-7
P-2312	6-7
P-2314	2-8, 2-9, 2-14, 2-15, 2-16, 2-17, 2-20, 2-21, 2-24, 2-40
P-2315	2-12
P-2316	2-12
P-2317	6-4
P-2318	6-4
P-2319	6-4
P-2320	6-4
P-2321	6-4
P-2326	3-0
P-2328	5-2
P-2329	5-2
P-2330	5-2
P-2331	5-0, 5-2, 5-4
P-2333	5-2
P-2335	5-2
P-2336	5-2
P-2337	5-2
P-2338	5-2
P-2339	5-2
P-2340	5-2
P-2341	5-3

Part No.	Page No.
P-2350	6-5
P-2352	6-5
P-2353	6-5
P-2354	6-5
P-2355	6-5
P-2356	6-5
P-2357	6-5
P-2358	6-5
P-2359	6-5
P-2360	6-5
P-2361	6-5
P-2362	6-5
P-2363	6-5
P-2364	6-5
P-2365	6-5
P-2366	6-5
P-2383	3-0
P-2390	5-0, 5-4
P-2391	2-0, 2-2, 2-13, 2-18, 2-31, 2-34, 2-37, 3-2, 4-4, 4-8, 5-0, 5-5
P-2392	5-0, 5-5
P-2393	5-0, 5-4
P-2394	5-0, 5-4
P-2395	4-2, 5-0, 5-4
P-2396	5-0, 5-4
P-2397	5-0, 5-5
P-2398	5-0, 5-5
P-2399	4-2
P-2404	5-3
P-2405	5-2
P-2406	5-3
P-2407	5-3
P-2408	5-2
P-2418	5-0, 5-4
P-2422	2-8, 2-21, 2-24
P-2423	2-8, 2-21
P-2425	1-1, 1-3, 1-5, 1-6, 1-8, 2-0, 2-2, 2-13, 2-18, 2-34, 2-36, 3-2, 4-6
P-2426	4-5
P-2427	2-18, 2-34, 3-2
P-2428	6-6
P-2429	6-6
P-2430	6-6
P-2431	6-6
P-2434	5-0, 5-5
P-2451	2-1, 2-3
P-2452	4-4
P-2455	2-0, 4-4
P-2456	6-10
P-2462	5-8, 6-10
P-2463	5-8, 6-1, 6-10
P-2464	6-10

Part No.	Page No.
P-2474	6-10
P-2475	6-10
P-2492	4-4
P-2493	2-38
P-2499	2-2
P-2502	5-0, 5-4, 5-10
P-2508	6-7
P-2509	6-7
P-2510	5-0
P-2518	4-2
P-2521	2-4
P-2523	2-1, 2-3
P-2525	4-2
P-2538	6-10
P-2539	6-10
P-2557	2-37, 4-2
P-2558	2-36, 4-2
P-2563	4-2
P-2564	4-2
P-2565	4-2
P-2573	4-2
P-2574	4-2
P-2575	4-2
P-2585	2-0, 2-2, 2-4, 2-18, 2-37, 3-2, 4-6
P-2590	2-0, 2-2, 2-18, 2-34, 2-36, 3-2, 4-4, 4-6
P-2592	2-18, 2-34, 2-36, 3-2, 4-6
P-2597	6-1
P-2599	5-4, 5-6
P-2603	4-4
P-2608	2-0
P-2611	2-0, 2-2, 4-4, 4-6
P-2612	2-0
P-2617	2-4
P-2618	2-4, 2-18, 2-26, 2-34, 2-37, 3-2
P-2619	4-2
P-2620	4-2
P-2621	2-37, 4-2
P-2622	2-37, 4-2
P-2623	2-0, 2-1, 2-2
P-2624	2-8, 2-9, 2-14, 2-15, 2-16, 2-17, 2-20, 2-21, 2-24, 2-40
P-2627	6-1
P-2635	2-0, 2-2, 2-18, 2-34, 2-37, 3-2, 4-4, 4-6
P-2636	2-0, 2-2, 2-18, 2-34, 2-37, 3-2, 4-4, 4-6

<i>Part No.</i>	<i>Page No.</i>
P-2637	2-4
P-2640	4-5
P-2646	2-18, 2-34, 3-2
P-2647	5-0
P-2648	2-18, 2-34, 3-2
P-2654	2-4
P-2669	6-12
P-2679	1-1, 2-13
P-2682	5-0, 5-4
P-2686	6-12
P-2687	6-12
P-2688	6-12
P-2689	6-12
P-2690	6-12
P-2692	6-12
P-2693	6-12
P-2694	6-12
P-2695	6-12
P-2696	6-12
P-2697	6-12
P-2702	6-12
P-2707	6-7
P-2708	6-12
P-2710	6-3
P-2711	5-1, 5-4, 5-5, 5-6, 6-9
P-2715	6-2
P-2725	5-4, 5-6
P-2726	5-4, 5-6, 6-5
P-2742	1-0, 1-2, 1-4, 2-12
P-2744	2-29, 2-37
P-2752	1-0, 1-2, 1-4, 1-10, 2-12
P-2754	5-0, 5-4, 5-8
P-2761	3-0
P-2763	3-0
P-2765	1-2, 1-4, 1-10, 2-6, 2-10, 2-12, 2-22, 2-30, 3-0
P-2766	2-0
P-2767	2-2
P-2768	4-4
P-2770	3-2
P-2773	5-3
P-2775	6-10
P-2777	6-10
P-2778	6-10
P-2779	6-10
P-2780	5-2
P-2781	5-2
P-2782	5-2
P-2783	5-2
P-2786	5-2
P-2788	5-2
P-2792	5-0, 5-5

<i>Part No.</i>	<i>Page No.</i>
P-2793	6-6
P-2794	5-3, 5-4, 5-6, 6-3
P-2795	6-2
P-2796	6-2
P-2798	5-0, 5-4
P-2799	2-4
P-2802	1-13, 1-15, 2-1, 2-32, 2-38
P-2803	2-0, 2-3
P-2804	6-10
P-2805	2-0, 2-2
P-2810	2-0, 2-2, 2-18, 2-34, 3-2, 4-5, 4-6
P-2814	2-36, 4-2
P-2822	3-0
P-2865	6-7
P-2866	6-7
P-2872	1-3, 2-13, 2-40
P-2873	1-2, 2-13, 2-40
P-2874	5-0, 5-4, 5-8
P-2875	1-3, 2-13
P-2876	1-3, 2-12, 2-13, 2-41
P-2878	2-4, 2-13, 2-18, 2-34, 2-37
P-2880	2-2
P-2892	2-22, 5-0
P-2897	6-4
P-2905	5-0, 5-4
P-2906	6-10
P-2925	5-4, 5-6
P-2936	2-0, 2-2, 2-37, 3-8
P-2938	5-4, 5-6
P-2954	2-0
P-2956	2-0
P-2983	5-0, 5-4
P-2987	1-0, 1-3, 1-5, 1-11, 2-13, 2-31
P-2993	5-6
P-2994	5-6
P-2995	5-6
P-2999	1-1, 1-3, 1-5, 1-13, 1-15, 2-0, 2-2, 2-9, 2-13, 2-15, 2-16, 2-37, 3-4, 4-4
P-3000	5-5
P-3002	2-18, 2-34, 2-40, 3-2, 3-6, 4-2, 4-6, 5-0
P-3003	5-6
P-3023	2-24, 3-8
P-3024	3-8, 3-10, 4-6
P-3025	3-8

<i>Part No.</i>	<i>Page No.</i>
P-3026	3-8, 3-10
P-3027	2-18, 2-24, 2-34, 3-8
P-3028	2-24, 3-8
P-3030	3-8
P-3031	3-10
P-3032	3-8, 3-10
P-3033	3-8, 3-10
P-3034	3-8, 3-10
P-3036	3-8
P-3038	3-10
P-3047	5-6
P-3048	5-6
P-3050	3-8, 3-10
P-3051	3-8, 3-10, 4-10
P-3055	5-8, 6-1
P-3061	1-11, 3-8, 3-10
P-3065	5-6
P-3066	5-8
P-3070	6-1
P-3071	6-1
P-3072	6-1
P-3073	6-1
P-3079	5-8, 6-7
P-3085	5-8, 6-1, 6-2
P-3192	1-3, 1-5
P-3193	2-18, 2-34
P-3241	2-18, 2-34
P-3245	1-6
P-3246	1-6
P-3247	1-6
P-3248	1-6
P-3253	3-4, 3-6
P-3254	3-4
P-3257	3-4
P-3258	3-4
P-3259	3-4
P-3271	2-18, 2-34
P-3321	6-1
P-3322	6-1
P-3328	2-22
P-3330	2-24
P-3331	1-8
P-3332	1-8
P-3333	1-8
P-3338	1-8
P-3339	1-8, 1-13, 1-15
P-3340	1-8
P-3341	1-8
P-3342	1-8
P-3343	5-17
P-3344	5-16, 5-17
P-3345	5-16, 5-17
P-3346	5-8
P-3347	5-8
P-3349	5-8

Part No.	Page No.
P-3350	5-8
P-3351	5-8
P-3352	5-14
P-3353	5-10
P-3354	5-8
P-3355	5-8
P-3356	5-8
P-3359	5-8
P-3360	5-10
P-3362	5-15
P-3364	5-8
P-3367	5-8
P-3368	5-11, 5-14
P-3369	5-8
P-3370	5-15
P-3372	5-16, 5-17
P-3373	5-8
P-3374	5-8
P-3375	5-8
P-3377	5-8
P-3393	5-11
P-3397	5-11, 5-14
P-3398	5-11
P-3400	5-13
P-3401	5-8, 5-14
P-3402	5-12, 5-13
P-3404	5-14
P-3408	2-22, 5-13
P-3410	5-16, 5-17
P-3411	5-16, 5-17
P-3412	5-14
P-3415	2-29, 2-38
P-3416	2-29
P-3417	2-28, 2-37
P-3418	2-29
P-3419	2-29
P-3420	2-29
P-3421	2-26, 2-28
P-3422	2-29
P-3423	2-28
P-3424	2-26, 2-28
P-3425	2-26, 2-28, 2-37
P-3426	2-26, 2-28, 2-36
P-3427	2-29
P-3428	1-15, 2-29, 2-40
P-3429	2-28
P-3430	2-28
P-3431	2-28
P-3432	2-26, 2-28
P-3438	2-26, 2-37
P-3441	2-26
P-3442	2-26
P-3443	2-26
P-3444	2-26
P-3445	2-26
P-3446	2-26
P-3447	2-26
P-3450	1-8
P-3452	1-8, 1-15, 2-40
P-3454	2-28
P-3456	5-8
P-3457	5-11
P-3458	5-11

Part No.	Page No.
P-3459	5-8
P-3480	4-6
P-3483	4-6
P-3484	4-6
P-3485	4-6
P-3486	4-6
P-3487	4-6
P-3488	4-6, 4-10
P-3489	4-6
P-3495	4-8
P-3501	4-6
P-3502	4-6
P-3504	4-6
P-3505	4-8
P-3506	5-16, 5-17
P-3513	2-26
P-3517	2-26
P-3518	2-26
P-3519	2-26
P-3522	2-26, 2-36
P-3524	2-26, 2-38
P-3525	2-26
P-3526	2-26
P-3528	5-8
P-3529	4-6
P-3530	2-28
P-3531	5-8
P-3532	5-8
P-3533	5-8
P-3534	5-8
P-3535	5-16, 5-17
P-3536	5-11
P-3537	5-15
P-3552	1-2, 1-4, 1-12, 1-14
P-3561	1-12, 1-14, 2-33
P-3562	1-13, 1-15, 2-32
P-3563	1-12, 1-13, 1-14, 1-15, 2-33
P-3570	1-11
P-3573	4-10
P-3584	1-13, 1-15
P-3586	1-13, 1-15, 2-32
P-3587	1-12, 1-14, 2-33
P-3588	1-11
P-3590	1-13, 1-15
P-3597	1-13, 1-15
P-3599	1-13
P-3600	1-13, 1-15
P-3603	1-13, 1-15
P-3605	1-13, 1-15
P-3606	1-13, 1-15
P-3611	1-11
P-3614	1-10
P-3626	2-26
P-3641	1-15
P-3643	3-6
P-3644	1-14
P-3645	3-6
P-3646	3-6
P-3647	3-6
P-3648	3-6

Part No.	Page No.
P-3651	2-32
P-3665	5-12
P-3666	5-12
P-3667	5-12
P-3668	5-8
P-3669	5-12
P-3670	5-12
P-3676	2-28
P-3690	2-38
P-3691	2-38
P-3692	2-38
P-3693	2-37, 2-38
P-3694	2-38
P-3695	2-38
P-3696	2-38
P-3697	2-38
P-3698	2-38
P-3699	2-38
P-3702	2-38
P-3703	2-38
P-3704	2-37
P-3707	2-38
P-3708	2-38
P-3710	2-38
P-3712	2-37
P-3713	2-37
P-3714	2-36
P-3715	2-37, 2-38
P-3716	2-36
P-3717	2-36
P-3718	2-40
P-3719	2-36
P-3720	2-36
P-3721	2-36
P-3722	2-36
P-3723	2-36
P-3725	2-37, 2-40
P-3726	2-36
P-3727	2-37
P-3729	2-37
P-3730	2-36
P-3736	2-37
P-3737	2-36
P-3740	2-36
P-3741	2-36
P-3742	2-36
P-3744	2-37
P-3745	2-37
P-3746	2-36
P-3747	2-36
P-3748	2-36
P-3749	2-37
P-3750	2-36
P-3775	2-40
P-3776	2-40
P-3778	2-40
EW-652	5-6
SN-676	4-1
SN-683	4-1
SN-685	4-1
SN-1067	4-1
SN-1087	5-6
SN-1088	5-6
SN-1089	5-6



**SUPPLEMENT TO  
NUMERICAL LIST OF PARTS  
FOR  
AM-1089 SYSTEM CONTROL CABINET**

<i>Part No.</i>	<i>Page No.</i>	<i>Part No.</i>	<i>Page No.</i>	<i>Part No.</i>	<i>Page No.</i>
G-2524.....	2-43	H-3440.....	2-42, 2-44, 2-45	P-3552.....	2-42, 2-44
G-2525.....	2-43	H-3523.....	2-42	P-3563.....	2-44
G-2526.....	2-45			P-3584.....	2-44, 2-45
G-2527.....	2-43	P-1145.....	2-43	P-3586.....	2-43, 2-45
G-2528.....	2-43	P-1146.....	2-44	P-3587.....	2-45
G-2531.....	2-43	P-1278.....	2-44	P-3588.....	2-44, 2-45
G-2532.....	2-45	P-2040.....	2-43, 2-45	P-3590.....	2-45
G-2533.....	2-43	P-2042.....	2-43	P-3605.....	2-44
		P-2048.....	2-44, 2-45	P-3606.....	2-44
H-1001.....	2-43	P-2075.....	2-45	P-3611.....	2-43
H-1005.....	2-44	P-2110.....	2-44	P-3695.....	2-43
H-1066.....	2-44	P-2122.....	2-44	P-3736.....	2-44
H-1540.....	2-43	P-2264.....	2-42	P-3744.....	2-44
H-2741.....	2-45	P-2316.....	2-42	P-3849.....	2-44
H-2747.....	2-44	P-2391.....	2-44	P-3850.....	2-45
H-3051.....	2-44	P-2744.....	2-43	P-3851.....	2-44
H-3218.....	2-44	P-2876.....	2-43	P-3853.....	2-45
H-3226.....	2-44, 2-45	P-2878.....	2-44	P-3854.....	2-44
H-3243.....	2-42, 2-43	P-2999.....	2-44	P-3855.....	2-43
	2-44, 2-45	P-3341.....	2-43	P-3856.....	2-42
H-3244.....	2-43	P-3342.....	2-42	P-3859.....	2-43
H-3341.....	2-45	P-3446.....	2-45	P-3861.....	2-44
H-3405.....	2-43, 2-44	P-3450.....	2-44	P-3866.....	2-42
H-3419.....	2-43	P-3526.....	2-45	P-3867.....	2-42
				P-3868.....	2-42

**SUPPLEMENT TO  
NUMERICAL LIST OF PARTS  
FOR  
PU-1014 POWER SUPPLY CABINET**

<i>Part No.</i>	<i>Page No.</i>	<i>Part No.</i>	<i>Page No.</i>	<i>Part No.</i>	<i>Page No.</i>
G-2381.....	4-9	H-3202.....	4-9	P-1266.....	4-8
G-2561.....	4-9	H-3226.....	4-8, 4-9	P-1267.....	4-9
		H-3324.....	4-9	P-3051.....	4-9
H-1054.....	4-9	H-3441.....	4-8, 4-9	P-3488.....	4-9
H-2714.....	4-8, 4-9	H-3445.....	4-9	P-3495.....	4-8
H-2724.....	4-9	H-3450.....	4-9		

# NATIONAL THEATRE SUPPLY

## ◆ BRANCHES ◆

ALBANY 4, NEW YORK	962 Broadway
ATLANTA 3, GEORGIA	187 Walton Street, N.W.
BALTIMORE 2, MARYLAND	417 St. Paul Place
BOSTON 16, MASSACHUSETTS	37 Winchester Street
BUFFALO 2, NEW YORK	500 Pearl Street
CHARLOTTE 1, NORTH CAROLINA	304 S. Church Street
CHICAGO 5, ILLINOIS	1325 S. Wabash Avenue
CINCINNATI 14, OHIO	1637 Central Parkway
CLEVELAND 14, OHIO	2128 Payne Avenue
DALLAS 1, TEXAS	300 S. Harwood Street
DENVER 2, COLORADO	2111 Champa Street
DES MOINES 9, IOWA	1102 High Street
DETROIT 1, MICHIGAN	2312 Cass Avenue
INDIANAPOLIS 4, INDIANA	436 N. Illinois Street
KANSAS CITY 8, MISSOURI	223 W. 18th Street
LOS ANGELES 7, CALIFORNIA	1961 S. Vermont Avenue
MEMPHIS 2, TENNESSEE	412-414 S. Second Street
MILWAUKEE 3, WISCONSIN	1027 N. 8th Street
MINNEAPOLIS 3, MINNESOTA	56 Glenwood Avenue
NEW HAVEN 10, CONNECTICUT	122 Meadow Street
NEW ORLEANS 12, LOUISIANA	220 S. Liberty Street
NEW YORK 36, NEW YORK	356 W. 44th Street
OKLAHOMA CITY 2, OKLAHOMA	700 W. Grand Avenue
OMAHA 2, NEBRASKA	1610 Davenport Street
PHILADELPHIA 7, PENNSYLVANIA	1225 Vine Street
PITTSBURGH 19, PENNSYLVANIA	1721 Blvd. of the Allies
ST. LOUIS 3, MISSOURI	3212 Olive Street
SAN FRANCISCO 2, CALIFORNIA	255 Golden Gate Avenue
SEATTLE 1, WASHINGTON	2319 Second Avenue

*Simplex*  
REG. U.S. PAT. OFF.

**ALWAYS**  
**THE FINEST**  
**IN**  
**SOUND AND PROJECTION**  
**EQUIPMENT**