

# FILM-TECH

**THE INFORMATION CONTAINED IN THIS ADOBE ACROBAT PDF FILE IS PROVIDED AT YOUR OWN RISK AND GOOD JUDGMENT.**

**THESE MANUALS ARE DESIGNED TO FACILITATE THE EXCHANGE OF INFORMATION RELATED TO CINEMA PROJECTION AND FILM HANDLING, WITH NO WARRANTIES NOR OBLIGATIONS FROM THE AUTHORS, FOR QUALIFIED FIELD SERVICE ENGINEERS.**

**IF YOU ARE NOT A QUALIFIED TECHNICIAN, PLEASE MAKE NO ADJUSTMENTS TO ANYTHING YOU MAY READ ABOUT IN THESE ADOBE MANUAL DOWNLOADS.**

**[WWW.FILM-TECH.COM](http://WWW.FILM-TECH.COM)**

FP-20

35 MM Projector

# Norelco<sup>®</sup> Service

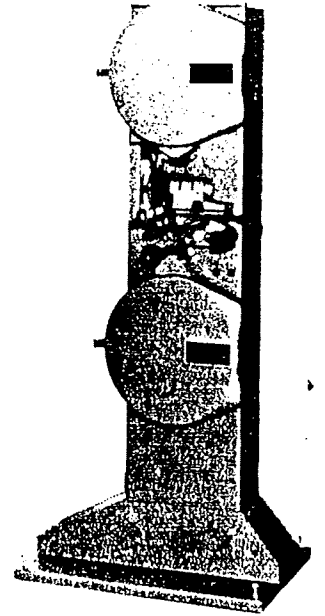

35 mm PROJECTOR

LCB 0020

LCB 0021

LCB 0015

SERVICE INFORMATION										
------------------------	--	--	--	--	--	--	--	--	--	--

*Norelco*

MOTION PICTURE  
EQUIPMENT

NORTH AMERICAN PHILIPS CORPORATION

Motion Picture Equipment Division

One Philips Parkway, Mahwah, New Jersey 07648

## TABLE OF CONTENTS

<u>LIST OF ILLUSTRATIONS</u> .....	ii
<u>INTRODUCTION</u> .....	1-1
<u>INSTALLATION</u> .....	Section 2-
Arrangement of Projection Booth.....	2-1
Positioning of Projection Portholes.....	2-3
Installation of Items Shipped Separate.....	2-6
Electrical Connections.....	2-9
Water-Cooling.....	2-10
Picture Changeover Dowser.....	2-10
<u>OPERATION</u> .....	3-1
<u>ADJUSTMENTS</u> .....	Section 4-
Torsion Spring of Pad Shoes.....	4-1
Clearance Between Pad Shoe and Sprocket.....	4-2
Film Stripper for Intermittent Sprocket.....	4-3
Tension of Upper/Lower Magazine Frictions.....	4-3
Belt Tension.....	4-3
Chain Wheels.....	4-4
Chains.....	4-4
Runner Plate and Pressure Skate.....	4-5
Shutter.....	4-5
Optical Soundhead.....	4-6
<u>REPLACEMENT OF COMPONENTS</u> .....	Section 5-
Plexiglass Rod of Optical Soundhead.....	5-1
Slit Objective.....	5-1
Pad Shoes.....	5-2
Sprockets - Upper/Lower.....	5-2
Intermittent Sprocket.....	5-3
Intermittent Sprocket Shaft.....	5-3
Intermittent Movement.....	5-4
Shutter.....	5-5
Bearings - Upper/Lower Sprocket Shafts.....	5-5
<u>LUBRICATION</u> .....	6-1
<u>PARTS CATALOGUE</u> .....	7-1
<u>LAMPHOUSE</u> - EL 4475 Incandescent.....	8-1

LIST OF ILLUSTRATIONS

<u>Figure Number</u>	<u>Description</u>	<u>Page Number</u>
1	..... Dimensions of Projector.....	2-1
2	..... Booth Layout.....	2-2
3	..... Lubrication Chart.....	6-4
4	..... Operating Side of Projector.....	7-3
5	..... Gate & Optical Soundhead.....	7-5
6	..... Non-operating Side of Projector.....	7-7
7	..... Electrical Control Panel.....	7-9
8	..... Magnetic Soundhead.....	7-11
9a	..... Rear Gate Assembly.....	7-13
9b	..... Intermittent Movement.....	7-13
9c	..... Upper Reel Friction.....	7-14
9d	..... Lower Reel Friction.....	7-14
10	..... Threading.....	7-15
11	..... Schematic - LCB 0020 Series.....	7-16
12	..... Electrical Diagram-LCB 0020 Series.....	7-17
13	..... Electrical Diagram-Earlier versions.....	7-18
14	..... Sound Changeover-FP20 & M2 Amplifier.....	7-19
15	..... EL 4475 Lamphouse.....	8-4
16	..... Lampholder.....	8-5
17	..... Condenser Lens Assembly.....	8-5
18	..... Motor - Electrical Strapping.....	8-6
19	..... Electrical Diagram - Lamphouse.....	8-6
20	..... Schematic - LCB 0015 Series.....	8-7
21	..... Adjustment Tools.....	8-8
22	..... Mirror Alignment Gauge.....	8-9

## INTRODUCTION

The new versions of the FP 20 series are supplied under LCB type numbers.

The components of the projectors of the LCB series are for the greater part identical to those of existing versions. The differences are indicated on page 1-2.

All the types comprise a basic projector with the addition of the components specific to the various versions.

### Possible versions

LCB 0020 (FP 20) = basic projector suitable for use with an arc lamp or Xenon lamp. (See page 1-2)

LCB 0021 (FP 20) = as LCB 0020 but equipped with a synchronous motor.

LCB 0015 (FP 20G) = basic projector equipped with a synchronous motor and with a lamphouse EL 4475 for incandescent lamp. (See pages 1-2 and 8-1)

The versions with synchronous motor differ from the versions with asynchronous motor on the following points:

- a synchronous motor for single-phase mains 220V, 60 Hz  
(Code number 4822 361 60057)
- a synchro belt for synchronous drive  
(Code number 4822 358 20006)

- pulley with 12 teeth  
(Code number 4822 522 30739)
- pulley with 25 teeth  
(Code number 4822 522 30742)

Only versions LCB 0020 and LCB 0021 are equipped with:

- a changeover relay  
(Code number 4822 280 60107)
- a dowser  
(Code number 4822 463 50016)

COMPONENTS OF THE FP 20 VERSIONS WHICH DIFFER FROM THOSE OF THE LCB VERSIONS

Changeover switch .....	4822	276	10007
Knob for changeover switch .....	4822	412	30008
Micro-switch for projector changeover .....	4822	271	30008
Window of shutter compartment .....	4822	381	10097
Main switch .....	4822	273	20008
Window for magazine .....	4822	480	50023
Time scale .....	4822	455	50001
Relay of the synchronous drive mechanism ....	4822	280	80052

BASIC PROJECTOR

Mains voltage

for asynchronous motor	110-220V
for synchronous motor	110-220V or 3 x 220/380V

Exciter lamp

5V, 4A .....	4822	134	80008
6.5V, 1.48A .....	4822	134	80007

Photocell ..... type 3546 PW

Solar cell ..... type EL 4402

The projector can be supplied with either 3000 ft. magazines or  
6000 ft. magazines.

The take-off direction of the upper magazine is counter-clockwise. A white arrow on the inside of the magazine prevents mistakes.

If the 3000 ft. magazines are replaced by 6000 ft. ones, the chain for the lower magazine should be extended.

An extension chain is supplied with each set of 6000 ft. magazines. Moreover, for 6000 ft. magazines, the upper spoolshaft bearing should be mounted on the extension bracket which is supplied.

The components required for adapting the projector for 4-track magnetic sound reproduction are supplied under type number EL 4028.

The projector is supplied with the short, oblique side of the pedestal at the front, this allowing of tilting max.  $15^{\circ}$  forward or backward.

For tilting angles larger than  $15^{\circ}$  forward, the long, oblique side of the pedestal must be at the front.

The following starting capacitors for the motor are used:

- 3 capacitors of 1 uF
- 1 capacitor of 4 uF
- 1 capacitor of 8 uF
- 1 capacitor of 12 uF

Upon delivery, the motor is adapted for 120V. An isolating transformer, the main switch and the fuses are mounted on the inside of the door (Fig. 7).

The isolating transformer has a 6V winding; the 6V voltage is necessary to shut the dowser. The isolating transformer feeds the motor relay.



Earlier versions of the projector (FP 20 series) were equipped with the following starting capacitors:

- 4 capacitors of 5 uF
- 2 capacitors of 2 uF
- 3 capacitors of 0.27 uF

Contacts 105-106 of the projector changeover circuit should be connected to an amplifier suitable for changeover by means of pulses.

On earlier projectors, contacts 103-104-103A-104A (Fig. 14) had to be connected to the contacts having the same number as the contacts of the amplifier.

## INSTALLATION

With the case resting on its three 4" x 4" skids (arrows pointing up) remove the top cover. Remove the cardboard cartons which contain arc lamp bracket, door, and other various small parts. The opened case should now be lifted so that the projector is standing up-right. Withdraw the nails holding the two 2" thick "U" shaped plywood collars and remove same; remove the four bolts. The projector can now be pulled out of the case. This is best done by pulling on the angle steel bracket. DO NOT USE THE BLACK KNOBS (focusing, framing, tensioning) or THE EXCITER LAMP HOLDER FOR THIS PURPOSE.

### Arrangement of the Projection Room

The principal dimensions of the FP-20 projector with 3000 ft. and 6000 ft. magazines (the latter indicated by dash lines) can be seen in Fig. 1.

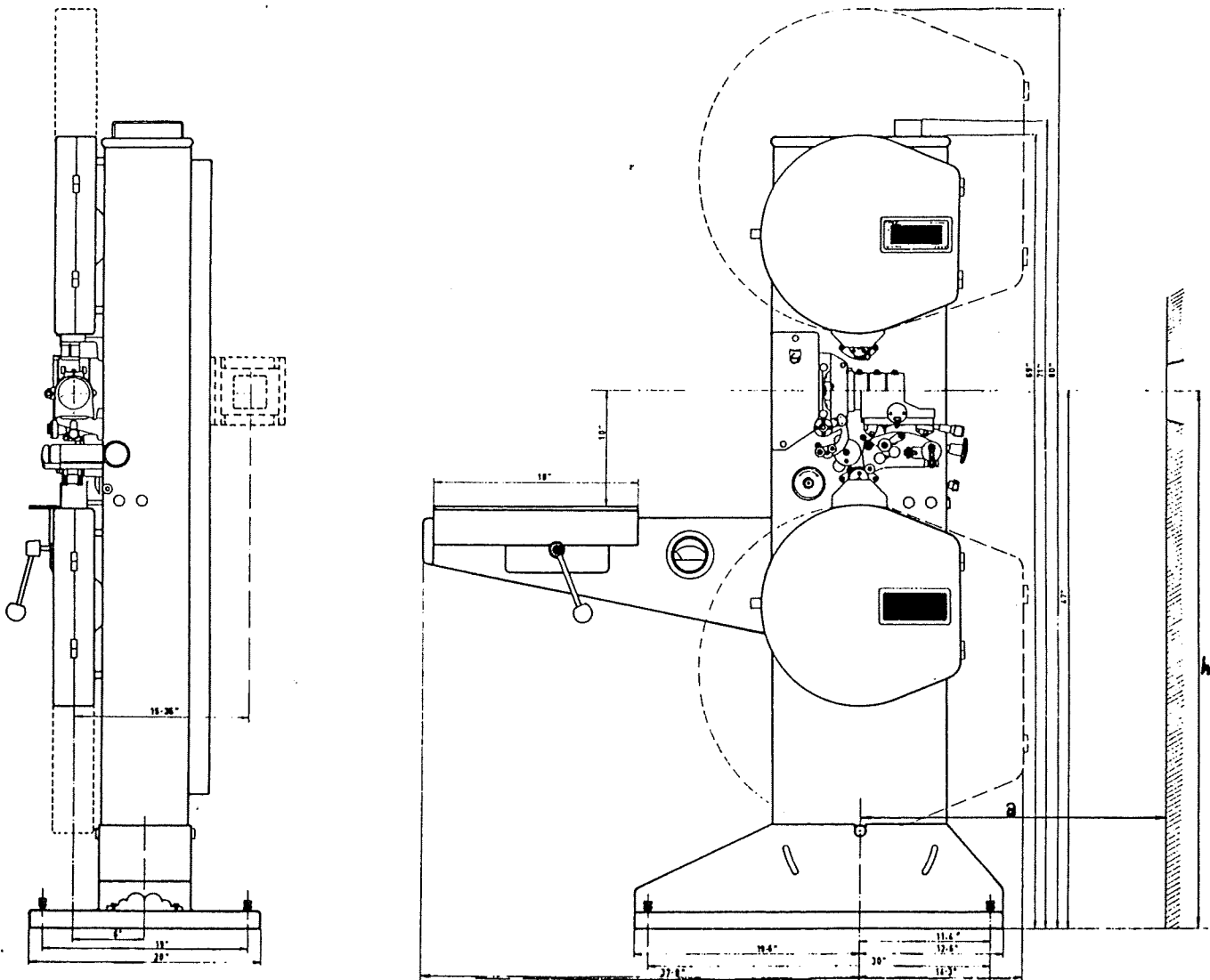

Fig.  
1

Arrangement of the Projection Room (continued)

Fig. 2 shows the typical positioning of a pair of projectors in a booth.

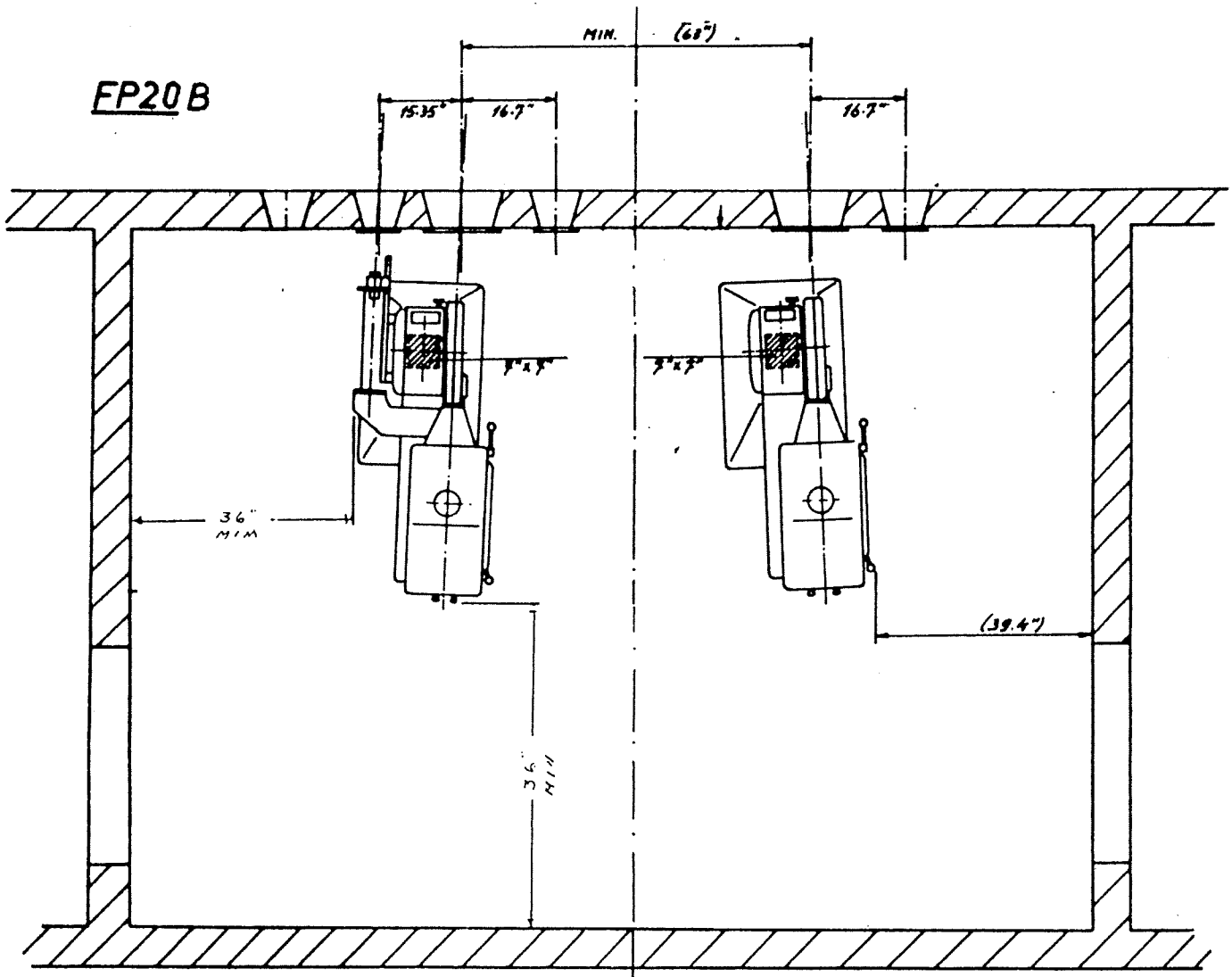

FIG. 2

NORELCO FP20B PROJECTORS  
TYPICAL BOOTH LAYOUT

Positioning of the Projection Port Holes (Fig. 1)

The height "h" of the center-line of the openings above the floor of the projection room and the distance "a" between the pivot of the projector and the front wall depend on the projection angle; they can be found in the following tables.

Values of "a" and "h" for FP-20 projectors with film path doors and either 6000 ft. or 3000 ft. magazines for projection angles between 15° upwards and 5° downwards

Projection angle	3000 ft. and 6000 ft. magazines	
	"a"	"h"
15°	1' 7-5/8"	4' 5-1/8"
14°	1' 7-5/8"	4' 4-5/8"
13°	1' 7-5/8"	4' 4-1/4"
12°	1' 7-5/8"	4' 3-5/8"
11°	1' 7-5/8"	4' 3-1/8"
10°	1' 7-5/8"	4' 2-3/4"
9°	1' 7-5/8"	4' 2-1/4"
8°	1' 7-5/8"	4' 1-7/8"
7°	1' 7-5/8"	4' 1-1/2"
6°	1' 7-5/8"	4' 1-1/8"
5°	1' 7-5/8"	4' 1-5/8"
4°	1' 7-5/8"	4' 3-1/8"
3°	1' 7-7/8"	3' 11-3/4"
2°	1' 8-1/2"	3' 11-3/8"
1°	1' 9-1/8"	3' 11-1/4"
0°	1' 9-5/8"	3' 10-7/8"
1°	1' 10-1/2"	3' 10-1/2"
2°	1' 11-1/8"	3' 10-1/8"
3°	1' 11-5/8"	3' 9-5/8"
4°	2' 1/8"	3' 9-1/4"
5°	2' 3/4"	3' 8-7/8"

Table A

Values of "a" and "h" for Projection Angles of more than 5° downwards for FP-20 projectors with film path doors

Projection Angle	3000 ft. magazines		6000 ft. magazines	
	a	h	a	h
6°	2'1-5/8"	3'8-1/2"	2'2-3/8"	3'8-3/8"
7°	2'2-1/8"	3'8"	2'3-1/4"	3'7-3/4"
8°	2'2-3/4"	3'7-1/2"	2'4-3/4"	3'7"
9°	2'3-1/4"	3'6-7/8"	2'5-7/8"	3'6-1/2"
10°	2'4"	3'6-1/2"	2'7-1/2"	3'5-7/8"
11°	2'4-5/8"	3'6"	2'8-5/8"	3'5-3/8"
12°	2'5-1/8"	3'5-5/8"	2'9-7/8"	3'4-1/2"
13°	2'4-5/8"	3'5"	2'11-1/8"	3'3-3/4"
14°	2'6-3/8"	3'4-1/2"	3' 3/8"	3' 3"
15°	2'7"	3'4"	3'1-5/8"	3'2-1/4"
16°	2'7-3/8"	3'3-3/8"	3'2-7/8"	3'1-3/8"
17°	2'7-7/8"	3'2-7/8"	3'3-7/8"	3' 3/8"
18°	2'8-5/8"	3'2-1/4"	3'5-3/8"	2'11-3/8"
19°	2'9-3/4"	3'1-5/8"	3'6-1/2"	2'10-1/4"
20°	2'10-5/8"	3' 5/8"	3'7-3/4"	2'9-1/2"
21°	2'11-7/8"	2'11-7/8"	3'8-7/8"	2'8-3/8"
22°	3' 5/8"	2'11-1/4"	3'10-1/8"	2'7-1/2"
23°	3'1-5/8"	2'10-1/4"	3'10-7/8"	2'6-3/8"
24°	3'2-5/8"	2'9-1/4"	4'	2'5-1/8"
25°	3'3-5/8"	2'8-1/4"	4'1-1/4"	2' 4"

Table B

Four leveling screws are also provided in the base. Four metal plates 2" x2" x 1/8" must be placed on the floor to support the leveling screws.

Distance between the column pivot point and the front wall:

For projection angles between 15° upwards and max. 10° downwards: the short oblique side of the base would face the front wall of the

projection room as shown in Fig. 1 (as shipped). The distance between the column pivot point and the front wall is then:

a - 1' 7-5/8".

To reverse the position of the base carefully lay the projector on its inspection door (non-operating) side suitably supported on a padded box or equivalent. Remove the 2 - hex head cap screws and washers from each side of the base. The base can then be slipped off the column, its position changed, and bolts replaced in the reverse order of removal.

There are two slotted holes on each side of the base and a series of threaded holes in the lower sides of the column. These holes plus the 4 hex head cap screws supplied provide facilities for setting at any projection angle from 15° up to 25° down.

In both cases, the Value "a" can be found in the following tables. Here follow some examples:

Examples:

- (a) The equipment consists of two FP20B projectors with 6000 ft. magazines. The projection angle is 5° downwards.

In this case, "a" = 2' 3/4" - see tables.

Distance between the column pivot point and the front wall of the projection room:

$$\underline{(a) 2' 3/4" - 10-7/8" = 1' 1-7/8"}$$

Height of the center of the projection-room window above the floor:

$$\underline{(h) = 3' 8-7/8" - see tables}$$

Examples (continued):

- (b) The equipment consists of two FP20B projectors with 6000 ft. magazines. The projection angle is  $12^{\circ}$  downwards.

In this case,  $a = 2' 9-7/8''$  - see tables.

Distance between the column pivot point and the front wall of the projection room:

$$\underline{(a) 2' 9-7/8'' - 19'' = 1' 2-7/8''}$$

Height of the center of the projection-room window above the floor:

$$\underline{(h) = 3' 4-1/2''} - \text{see tables.}$$

For shipping purposes the inching knob has been removed from the motor shaft and the chain sprocket has been removed from the holdback shaft.

INCHING KNOB

Push the knob onto the motor shaft and rotate it so that the pin in the shaft engages the slot in the rear of the knob.

Install the screw and washer supplied to fasten the knob in place.

CHAIN SPROCKET

(a) Loosen the hollow head screw in the holdback sprocket sufficiently to clear the shaft.

(b) From the driving side carefully push the holdback shaft toward the film side for about  $1-1/2''$ .

(c) See Fig. 6 - in Parts List Section. Hold the fibre chain sprocket so that a few teeth engage the right side of the chain as viewed and the sprocket bore lines up with the shaft.

(d) Push the holdback shaft from the film side so that it enters the chain sprocket bore and the shaft is flush with the outer face of the film sprocket.

(e) Align the film sprocket so that the set screw will strike the flat on the shaft and tighten screw.

(f) Rotate the film sprocket shaft assembly and/or the chain sprocket so that the set screw will strike the flat on the shaft.

(g) Push the film sprocket and the chain sprocket toward each other and tighten the chain sprocket set screw against the shaft flat.

(h) Test for end play and adjust the chain sprocket if necessary to obtain a slight, just perceptible end play of the shaft.

After moving the projector into its approximate final position:

(a) In the projector base, four holes for hold-down bolts are provided to supply support when using heavy lamphouses.

(b) Before inserting screws arrange the two angle brackets supplied for mounting the 3000 ft. magazines so that the threaded holes face the film side of the column. These two brackets receive the two upper screws for holding the top magazine. Insert the screws in the top of the column but do not tighten.

(c) Install the upper magazine with four flat-head screws and countersunk washers.



(d) Align the magazine and tighten all screws well.

(e) Assemble the door half hinges and install door and upper hinge assembly on the projector.

(f) Install the sound drum flywheels on their respective shafts. Each magnetic capstan takes 3 discs, and the optical capstan is equipped with 7 discs.

(g) Place the "V" belt first on the intermittent pulley and then on the motor pulley. If necessary back off the rear nut on the belt tensioning stud mounted in the rear wall of the column. This will allow lifting the motor for easier belt installation. The loosened nut should be returned to its original position after the belt is installed. "V" belts should not be tight. Only enough tension is required so that the motor is brought to a stand-still when the intermittent flywheel is stopped.

(h) Remove the plastic cap from the oil filler tube on the intermittent. Fill with Cat. No. 3672 oil up to the green circle on the plastic tube (see Lubrication Chart) (Page 6-1).

(i) The lens holder will be found in one of the cartons. Before assembling the machined slides and the corresponding areas on the lens bracket should be wiped clean and then lubricated with EL 4854 Guide Grease. To install the lens holder push back, toward the lamphouse, the plunger in the lens bracket. It will lock in the

"open" position. Slip the focus gauge on the lens holder over the stud in the side of the bracket and drop the "T" stud in the space between the plunger and the end of the focusing screw so that the holder seats on the bracket slides. Pull the small knurled knob, found under the lens bracket, toward the operating side to release the plunger spring and provide focusing control.

(j) The curved fibre glass skate can be placed on the ball end stud after the lever is operated to its open position.

The projector can now be run after the electrical connections are made.

#### ELECTRICAL CONNECTIONS

The wiring in the projector is shown in Fig. . External wiring required consists of:

- (a) One pair of conductors between power distribution panel in the booth and Terminals 20-60 in the projector. These wires are to supply 110 volts, 60 cycles, to the projector motor and upper magazine lamp socket. Terminal 20 should be connected to the "ground" side of the A.C. supply fuse for 10 amperes.
- (b) A #10 conductor should be connected to the grounding stud located at the lower center of the column on the driving side. Usually this wire should go to the main ground point of the amplifying system from which point a conductor is run to a cold water pipe.
- (c) The Exciter Power Supply is to be connected to Terminals 80-81. Two types of exciter lamps are available, namely: Cat. No. 3874 which operates at 6.5V, 1.48A; or Cat. No. 7251C which requires a 5V, 4A supply which is supplied with the projector.

- (d) The photo electric cell cable should be kept as short as possible. A jacketed tri-axial cable (double shield) such as the Amphenol 21-204 is recommended. Connect as follows:

Core-----to anode.  
Internal Shield---to cathode.  
Outer Shield-----to amplifier ground at  
amplifier end.

DO NOT CONNECT projector end of the Outer  
Shield.

The photocell is a type 3546PW (similar to the  
RCA 927 and CE 36C).

If an EL 4402 solar cell is used, Belden #8761 shielded  
twin lead or equivalent should be used.

#### WATER COOLING

Two 3/8" I.D. x 5/8" O.D. hoses will be found inside of the projector column leading the water-cooled aperture and baffle. These hoses can be connected to a water re-circulator or to a non-recirculating water supply and drain. In the latter case, a shutoff valve must be placed in the water input line. Connections can be made inside of the column or the hoses can be brought out, on the floor, through the openings covered by removable plates, at the center front and rear of the trim skirt. Water flow with the higher powered arc lamps, should be 1/3 to 1/2 gallon per minute.

#### PICTURE CHANGE OVER DOWSER

The built-in coils require 6V, A.C. at 2 amperes each for dependable operation. During operation one coil in each machine is always energized.

To this 4 ampere drain is added that of the framing lamps. A supply with a minimum capacity of 5 amperes at 6V is necessary. The required power supply and relay is included in NORELCO amplifiers.

SOUND HEADS

OPTICAL

PEC - Amperex 3546PW (RCA-927/CE-36C)

EXCITER - Philips 5V, 4A Prefocus - Type 7251C  
(Philips 6V, 1.48A Prefocus - Type 3874C - Optional)

Required amplifier input sensitivity - 1.4 mV

PEC voltage - 90V nominal (reducible to 65V for balancing)

Required gain - 100 Db

Typical Philips Amplifier:

Input Impedance = 20,000 ohms

Input Volts = 0.6 mV

Hum/Noise - 66 Db

Output = 100V/500 ohms/1 KC

Exciter Power Supply Ripple = 180 mV

SOLAR CELL - Norelco EL 4402

Required amplifier input sensitivity - 5 mV at 500 ohms

DO NOT USE POLARIZING VOLTAGE

MAGNETIC

Required amplifier sensitivity = approx. 1.7 mV

Required gain = 135 Db (for nominal output voltage at 1 KC)

Typical Norelco CinemaScope Amplifier

Channels 1-2-3

Input Impedance = 0.35 mV/1 KC

Hum/Noise - 52 Db

Output = 100V/500 ohms/1 KC

Impedance Magnetic Head = 5 mh

Fuses

The projector is shipped wired for 117 VAC. The fuseholders have the 974/V4000 fuse installed.

NOTE:

The left-hand fuseholder should be strapped out of the circuit to prevent the possibility of the neutral leg's opening up. If this fuse is left in the circuit and blows, there is a serious shock hazard.

## OPERATION

To operate the projectors, the following data should be utilized:

- Turn the framing device to its middle position (white dot upwards).
- Open the pressure skate by means of the lever.
- Thread the film into the projector (Fig. 10) while the intermittent sprocket is in a locked position.
- Inch the projector for checking the two loops.
- Start the projector and focus the picture.
- Check the pressure of the skate. To adjust it, turn Knob 11 (Fig. 4) counter-clockwise until the picture starts jumping, then turn the knob clockwise until the picture is just steady.

### WARNING:

Excessive skate pressure will result in excessive wear of the film, the intermittent sprocket, the runner strips and the skate. It is important to keep the skate pressure as low as possible without the picture jumping.

### Automatic film-rupture device

In the earlier projectors (FP 20 series) a device located above the gate aperture operates a micro-switch in the event of film break, interrupting the control current for the motor relay and stopping the motor.

In the new versions of the projectors (LCB series) this is effected by means of a centrifugal switch which is driven by a roller in the fire trap of the lower magazine. Consequently, the centrifugal switch operates only when film runs through the projector. The centrifugal switch is connected in series with the motor relay.

To make it possible to start the projector, the centrifugal switch is shunted by a contact on Relay Re2 when the projector is not running.

## ADJUSTMENTS

After each of the following adjustments, check that the film runs through the projector without being damaged.

The adjustments mentioned in the following pages have been done in the factory; they need only be repeated when necessary; for example - after the replacement of components.

### ADJUSTMENT OF THE TORSION SPRING OF THE PAD SHOES

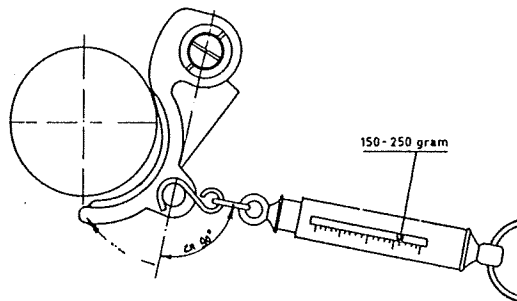

Adjust this spring so that the pad shoes are closed at a counter-force of 150-250g, measured with a spring balance (See sketch).

Required tools:

- an offset screwdriver - Code number 4822 395 50032
- a spring balance of 0-1000g



A burr on the saw-cut of the tension cap (for tensioning the torsion spring) may cause difficult pad shoe movement; the latter may even remain open. In that case, proceed as follows:

- Remove the pad shoe and file off the burr.
- Refit the pad shoe, and lubricate well with Cardan oil, type 8657.

#### ADJUSTMENT OF THE CLEARANCE BETWEEN THE PAD SHOES AND THE SPROCKETS

If the clearance between the pad shoe and the sprocket is insufficient, this may cause accumulation of dirt and damage the film.

The clearance between the pad shoes and the sprockets should be twice the film thickness. The clearance can be adjusted with the stop screw at the rear of the pad shoes, in one of the following ways:

##### First method

- Turn the stop screw counter-clockwise.
- Insert three pieces of film between the pad shoe and the sprocket.
- Insert a piece of paper between the stop screw and the stop.
- Turn the stop screw clockwise until it touches the stop.
- Remove the piece of paper; the clearance between pad shoe and sprocket is then correct.

##### Second method

- Connect a 6V flashlight battery (or a transformer) with a lamp, a bell or a buzzer in series with the steel control lever of the pad shoe and the casting on which the pad shoe is mounted.
- Insert three pieces of film between the pad shoe and the sprocket. The lamp should not light or the bell or buzzer should not be actuated. If they do, turn the set screw slightly.

## ADJUSTMENT OF THE FILM STRIPPER NEAR THE INTERMITTENT SPROCKET

This stripper should spring back smoothly after it has been lifted.

Sticking may cause damage to the film; in the case of sticking proceed as follows:

- Remove the spring and loosen the two locking nuts.
- Loosen the two set screws approximately one turn.
- Tighten the locking nuts and refit the spring.
- Lubricate the stripper with Esso Handy Oil..

## ADJUSTMENT OF THE TENSION FRICTIONS OF THE UPPER AND LOWER MAGAZINES

### Upper Friction

- Adjust this friction so that no loops are formed when the projector is stopped.

### Lower Friction

- If the projector is equipped with 6000 ft. magazines, it is recommended to adjust the lower friction coupling so that, when 3000 ft. magazines are used, the tension on the film is not too high. This can be achieved by decreasing the capacitance of the starting capacitors to 20  $\mu$ F at 110V. The tension on the film with a full 6000 ft. reel must then be 200g.

## ADJUSTMENT OF THE BELT TENSION

The belt must be as slack as possible. If, however, while the projector is running, the flywheel of the intermittent unit is stopped by hand, the motor must also stop. Use a cloth for braking the flywheel,

being careful of the three notches. In case of long belts, the motor shaft may touch the edge of the hole behind the inching knob; in that case, slightly file out the hole.

#### ADJUSTMENT OF THE CHAIN WHEELS

The backlash between the chain wheels should be as small as possible, but just perceptible.

- Adjust the backlash by shifting the intermediate gear wheel with the aid of a 5mm Allen key; tighten the Allen screw firmly after adjustment. (See Fig. 9b - Item 24.)

Allen screw 24 is accessible through a 1/2-inch hole in the column on the operating side of the projector, to the left of the lensholder mounting bracket.

#### ADJUSTMENT OF THE CHAINS

It is recommended to check the chains regularly for links which impede smooth running. In most cases a light tap on the link is sufficient to remedy this fault.

The chains must not be taut; slack chains run more smoothly. However, the lower chain should not be so slack that the take-up sprocket can be turned by hand.

The chains have to be lubricated with Esso Handy Oil.

NOTE: If after the above adjustments are made, travel ghost occurs, adjust the shutter (page 4-5).

#### ADJUSTMENT OF THE RUNNER PLATE AND THE PRESSURE SKATE

The runner plate is provided with Delrin runner strips instead of the Novotext, steel or velvet-covered strips formerly used. To replace the runner strips on existing projectors with Delrin strips, the block to which the spring of the magnetic soundhead tension roller is fixed has to be filed off.

The strips can be removed by loosening the knurled screws. The ceramic rollers can readily be taken out. To adjust the skate pressure, proceed as follows:

- Close the skate by means of the lever.
- Loosen the set screw, push the skate with the bottom curved part against the bearings, and tighten the set screw so that the skate remains in this position.
- Start the projector with film.
- Turn the knob for adjusting the skate pressure counter-clockwise until the picture starts jumping, then turn the knob clockwise until the picture is just steady again.

#### ADJUSTMENT OF THE SHUTTER

- Remove the shutter housing, pushing the film stripper downwards. The screws in the clamping ring of the shutter are then accessible through a hole in the light cut-off disc.
- Loosen the screws of the clamping ring.

#### Coarse adjustment:

- Thread the projector with film having black frame lines and a clear frame.
- With the picture in frame, turn the projector down by hand until the frame line is in the middle of the aperture.

### Coarse adjustment (continued)

- Adjust the shutter so that the center of the blade is opposite the center of the aperture.
- Tighten the three locking screws.

### Fine adjustment:

- With the aid of a test film or a picture with titles, check whether the picture has travel ghost. If necessary, turn the shutter in its direction of rotation in case of travel ghost at the top of the picture, and in the opposite direction in case of travel ghost at the bottom of the picture.

### ADJUSTMENT OF THE OPTICAL SOUNDHEAD

The pressure roller arm is provided with a stop to prevent the roller from resting against the sound drum without film. The pressure can be measured with a spring balance.

After replacement of the optical system or the pressure roller, the soundhead should be adjusted with the proper test films in the following way:

- Slightly loosen screw F (Fig. 4).
- Turn the optical system with the aid of spanner 4822 395 50011 so that the slit is as nearly perpendicular as possible to the sound track of the film (azimuth adjustment).
- Thread a 7000 Hz Sound Focusing Type B test film (SMPTE P35SFB) into the projector.
- Loosen the screw of the focusing ring, and focus the optical system provisionally.
- Position the slit exactly perpendicular to the sound track of the film with the aid of the spanner (maximum deflection of the meter).
- Thread a 9000 Hz Sound Focusing Type A test film (SMPTE P35SFA) into the projector, and again focus the optical system (maximum deflection of the meter).

## REPLACEMENT OF COMPONENTS

### REPLACEMENT OF THE PLEXIGLASS ROD OF THE OPTICAL SOUNDHEAD (if broken or damaged)

- Remove the protecting cap of the photocell.
- Loosen the now accessible screws of the fixing ring.
- Replace the rod, taking care that the front face of the new rod remains approximately 0.020" (0.5mm) from the front rim of the sound drum.
- Check whether the light of the optical system falls on the rod. If not, loosen the fixing screws of the photocell holder and slightly turn the assembly photocell holder + rod.
- Check that the rod still has the correct clearance 0.020" (0.5mm) with respect to the front edge of the sound drum.

### REPLACEMENT OF THE SLIT OBJECTIVE

- Carefully remove the fixing pin of the flywheel, and the flywheel.
- Take out the plexiglass rod.
- Remove the rear bearing and the sleeve on the shaft between the bearings.

The slit lens can now be replaced.

#### Mounting:

In the reverse order; after having mounted the sound drum, place the plexiglass rod in the correct position (see previous section).

### REPLACEMENT OF THE PAD SHOES

- Loosen the Allen screws which releases the spring (See Fig. 4 Allen locking screw for Item 5.)
- Take the pad shoe from its shaft.
- After mounting, adjust the tension of the spring (See page 4-1).
- Lubricate with Cardan oil, type 8657.

### REPLACEMENT OF THE UPPER AND LOWER SPROCKETS

- Open the rear door of the projector.
- Loosen the set screw of the sprocket.
- From the rear of the projector, loosen the set screw of the chain wheel.
- While holding the chain sprocket and chain in position, push on the shaft from the film sprocket side until the latter can be lifted from the bracket-stripper.
- Remove the sprocket (which is retained by the pad shoes).

If the teeth are worn in one direction only, the sprocket may be reversed; if the other side of the teeth is also worn, the toothed discs have to be replaced. To adjust them, using gauge - Code number 4822 395 80016, proceed as follows:

- Pass the pin of the gauge through the components of the sprockets in the order in which they are to be mounted, and fix one toothed disc with three screws.
- Adjust the second disc with the aid of the gauge, and tighten the three screws. Code number of one pair of toothed discs: 4822 522 30466.

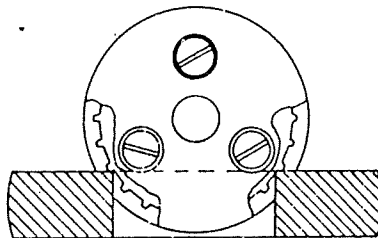

ERE 3753

## REPLACEMENT OF THE INTERMITTENT SPROCKET

### Removal:

- Take out the set screw of the intermittent sprocket.
- Loosen the locking screw of screw 18 (Fig. 5) and loosen screw 18.
- Remove the bearing from the sprocket shaft (4 screws).
- Slide the sprocket from its shaft.

### Mounting:

- Slide the sprocket onto its shaft.
- Install the bearing and secure it in place with the four screws.
- Tighten screw 18, then loosen it a quarter turn, and tighten the locking screw.
- Turn the framing knob clockwise.
- Insert a piece of paper (0.002") between the rear flange of the sprocket and the bearing and push the sprocket gently against the paper.
- Tighten the set screw of the sprocket, then remove the paper.
- While turning the framing knob, check whether the sprocket has visible play.

## REPLACEMENT OF THE INTERMITTENT-SPROCKET SHAFT

- Drain the oil from the intermittent movement.
- Disconnect the electrical connections for the framing lamp.  
If the framing lampholder is secured to the column instead of the gate casting, it is not necessary to disconnect the framing lamp connections.
- Remove the lampholder.
- Remove the four screws which hold the gate casting and then remove the runner plate.
- Loosen the locking screw of screw 18 (Fig. 5) and loosen screw 18.



- Remove the intermittent sprocket's set screw.
- Remove the sprocket shaft from the rear of the casting.
- Insert a new shaft with the sprocket; do not fix anything.
- Carefully mount the gate casting taking care not to damage the teeth of the framing bushing while meshing them with the sprocket shaft.
- Secure the gate casting with the four screws.
- For mounting the sprocket, see preceding paragraph.
- Re-connect the framing lamp wires if disconnected previously.
- After mounting, fill the intermittent mechanism with type 3672 oil.

Code number of the sprocket shaft  
of the earlier projectors ..... 4822 522 30407

Code number of the sealing ring for  
this shaft ..... 4822 532 40006

Code number of the present sprocket  
shaft ..... 4822 522 30947

Code number of the sealing ring for  
the latter shaft ..... 4822 530 50427

REPLACEMENT OF THE INTERMITTENT MOVEMENT

- a. Remove the driving belt and the chains.
- b. Drain the oil.
- c. Remove the shutter housing, taking care not to damage the film stripper.
- d. Remove the dowser behind the film gate (loosen the two screws at the bottom).
- e. Remove the bracket on which the heat-protection plate is mounted.
- f. Remove the hexagon screw of the shutter shaft.
- g. Remove the light cut-off disc, if present.
- h. Loosen the three screws in the fixing ring of the shutter; remove the ring and the washer.
- i. Loosen the locking screw of screw 18 (Fig. 5), and loosen screw 18.
- j. Remove the four screws of the intermittent movement (front of the projector) and take out the intermittent movement.

Mounting: In the reverse order

- Adjust screw 18 and the sprocket (see preceding section).
- Check the adjustment of the intermittent sprocket for the .002" clearance.
- After having mounted the chains, check that they are properly tensioned.
- Adjust the gear mesh of the shutter drive gear for just perceptible play.

REPLACEMENT OF THE SHUTTER

- Carry out instruction c through i of the preceding section.

REPLACEMENT OF THE BEARING OF THE UPPER AND THE LOWER SPROCKETS

- Remove the chain.
- Remove the sprocket (See page 5-2).
- Remove the holder (two screws).

LUBRICATION CHART

PART	Time	Lubricant *	Quantity
A Felt disc supply friction	Every Quarter	Universal Grease	Thoroughly
B Intermittent Movement - SEE UNDER INTERMITTENT MOVEMENT			
C Novotext gear wheel	Weekly	Slide Grease	Lubricate
D Chains	Weekly	Esso Handy Oil	Few drops
E Coupling framing shaft	Weekly	Cardan Oil	
F Threaded end spindle	Weekly	Cardan Oil	
G Switch slit plate (earlier projectors)	Weekly	Cardan Oil	
H Pin and spring of switch (earlier projectors)	Weekly	Cardan Oil	
J Felt disc take-up friction	Every Quarter	Cardan Oil	
K Thread focusing knob	Every Quarter	Esso Handy Oil	Few drops
L Lensholder sliding surface & support sliding surface	Monthly	Slide Grease	
M Spring and pin	Every Quarter	Slide Grease	Sparingly
N Front side bearing - Intermittent Shaft	Weekly	Esso Handy Oil	Few drops
O Piston-pins-ceramic discs	Weekly	Esso Handy Oil	

\*Cardan Oil-8657  
 Esso Handy Oil  
 Projector Oil-3672  
 Slide Grease-EL4854  
 Universal Grease-EL4855

LUBRICATION CHART (continued)

PART	Time	Lubricant *	Quantity
P Hinge of pad roller <u>Note:</u> Lubricate by pulling pad roller forward so that part of shaft becomes free.	Monthly	Cardan Oil	
Q Changeover relay	Weekly	Esso Handy Oil	
Pivot dowser	"	"	
Groove of tension pin	"	"	
R Spring pivot (2x)	Every Quarter	Esso Handy Oil	One drop
S Lever pivot	Monthly	Cardan Oil	
T Lever pivot of pressure roller	Monthly	Slide Grease	Sparingly
Ball bearings of pad roller	Monthly	Projector Oil	Few drops
V Spindles of guide rollers	Monthly	Esso Handy Oil	One drop - spread with fingers
W Ball bearings of capstan	After servicing	Esso Handy Oil	Lubricate

NOTE: DO NOT GREASE/OIL GUIDE ROLLERS

\*Cardan Oil-8657

Esso Handy Oil

Projector Oil-3672

Slide Grease-EI4854

Universal Grease-EI4855

LUBRICATION (continued)

Intermittent Movement

The oil to be used for the Intermittent movement is Type 3672.  
In a new projector or after replacement of an intermittent movement,  
change the oil as follows:

After 20, 50, 100, 200 and 250 running hours;  
thereafter, regularly every 250 hours.

Back Door (every Quarter)

Lock Screw	A few drops of
Hinge	Esso Handy Oil

Door (Monthly)

Bolts - Slide grease - sparingly  
Hinge - A few drops of Esso Handy Oil  
Head of adjusting screw in door - Slide Grease - sparingly

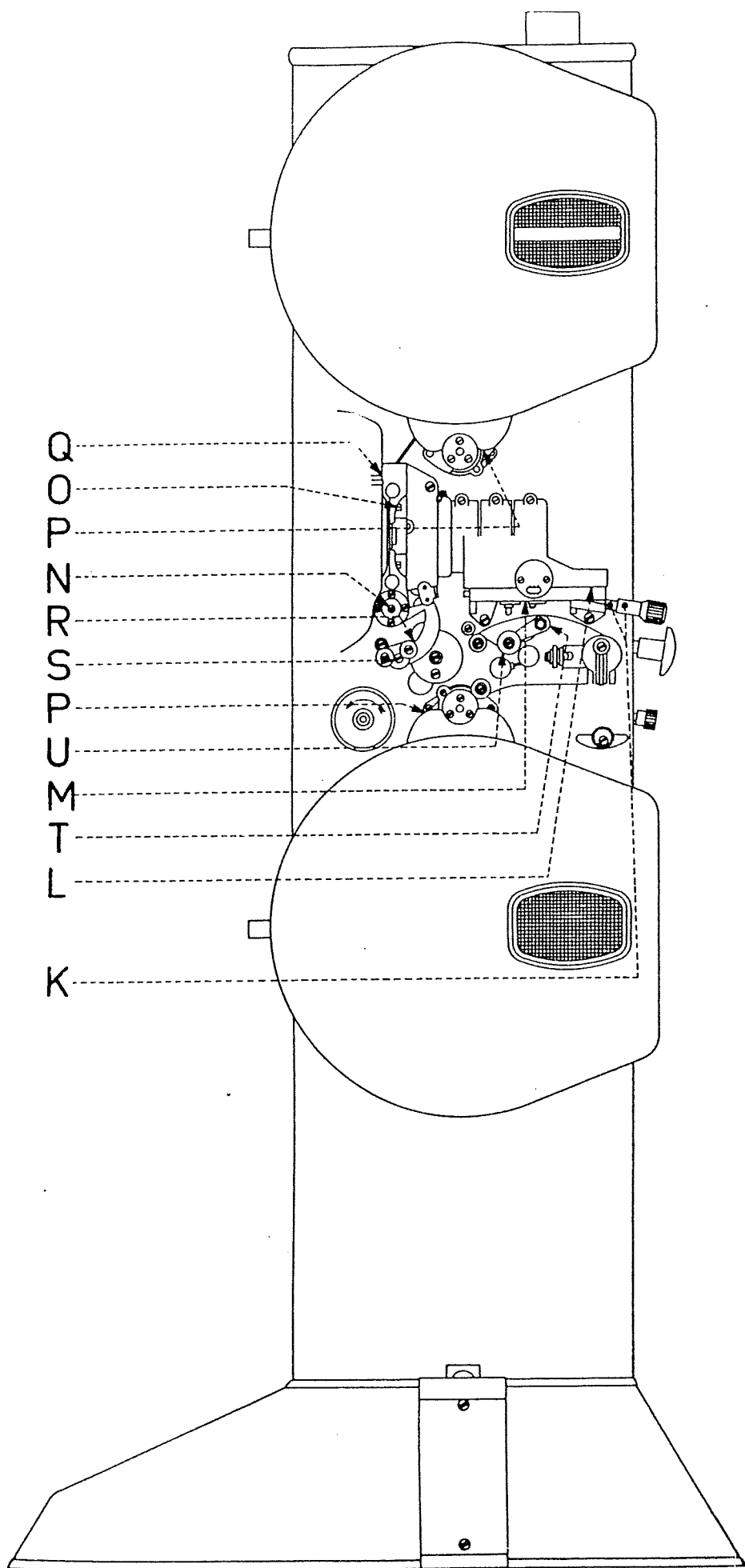

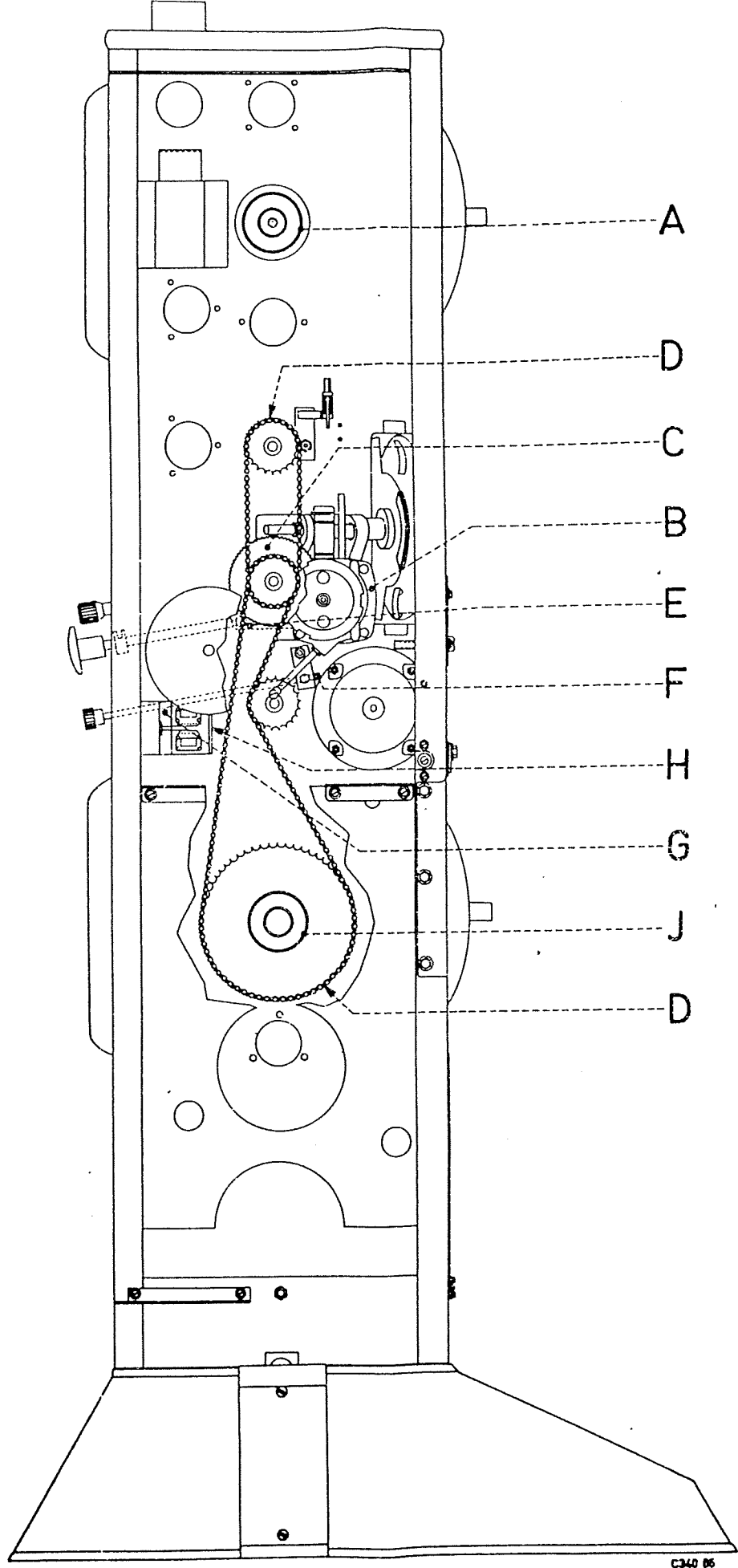

A

D

C

B

E

F

H

G

J

D

C340 06

Fig.  
3

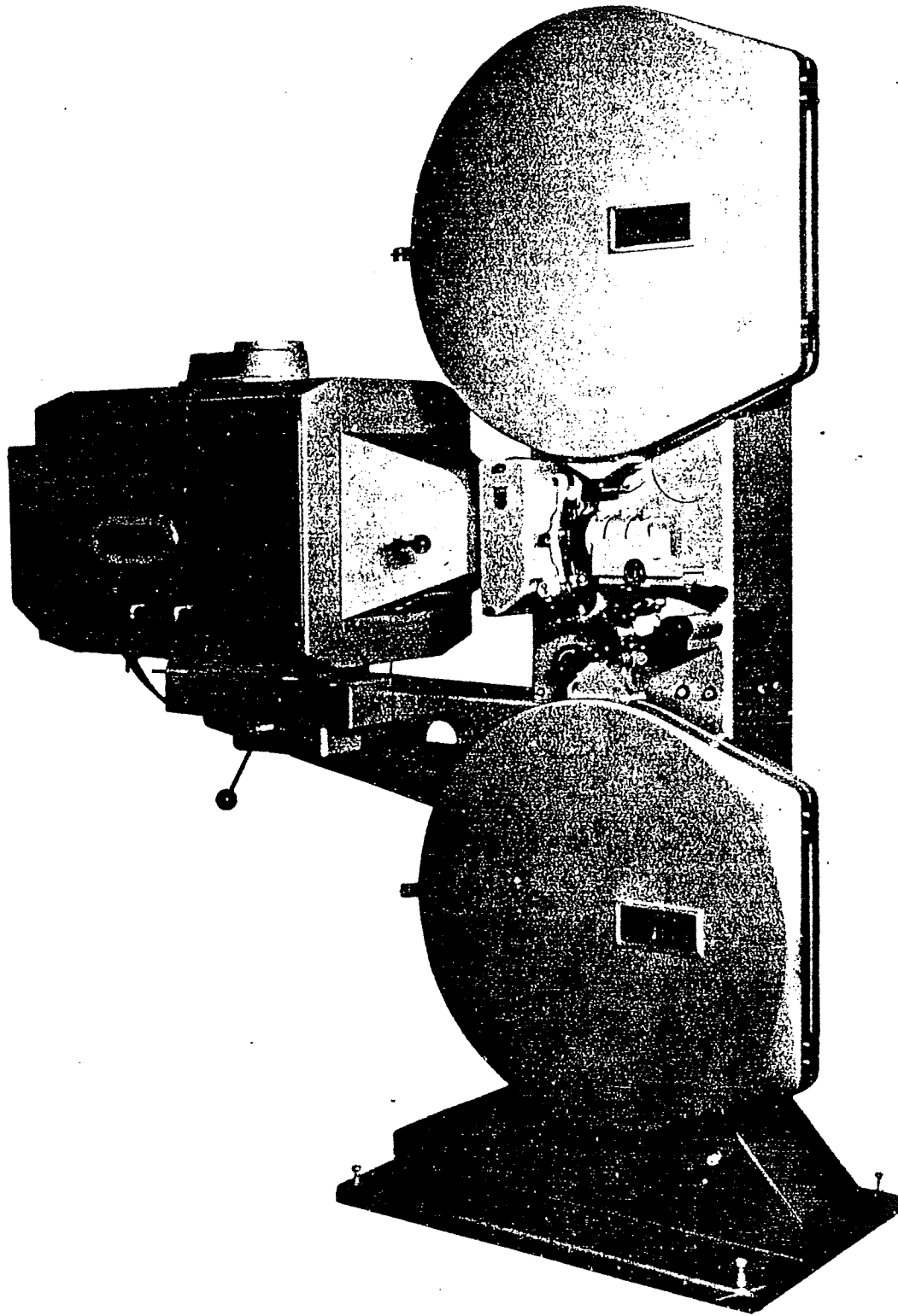

ERE 3784

LCB 0020 - LCB 0021



Item	Code Number	Description
1	4822 528 20011	Upper friction (see Fig. 9)
2	4822 417 60045	Door lock
3	4822 417 10172	Hinge
4	4822 492 40001	Spring
5	4822 462 50027	Tension nut
6	4822 525 30003	Pad shoe
7	4822 450 30018	Scale
8		Lens adjusting knob
9	4822 413 10007	Framing shaft with knob
10	4822 381 20004	Sound lens assembly
11	4822 535 80016	Skate pressure adjustment
11a	4822 413 40152	Knob for skate pressure
12	4822 276 10134	Start knob
13	4822 276 10114	Knob
14	4822 459 20121	Ornamental window
15	4822 <del>535 70027</del> 693-50008	Lower spoolshaft
16	4822 522 30466 104	Sprocket Set sprocket discs
17	4822 413 60036	Inching knob
18	4822 535 50014	Sound shaft
19	4822 520 20047	Ball bearing
20	4822 492 40036	Spring in objective guide
21	4822 505 10192	Knurled nut
	4822 134 40113	Framing lamp
	4822 134 40201	Framing lamp
	4822 134 80007	Exciter lamp

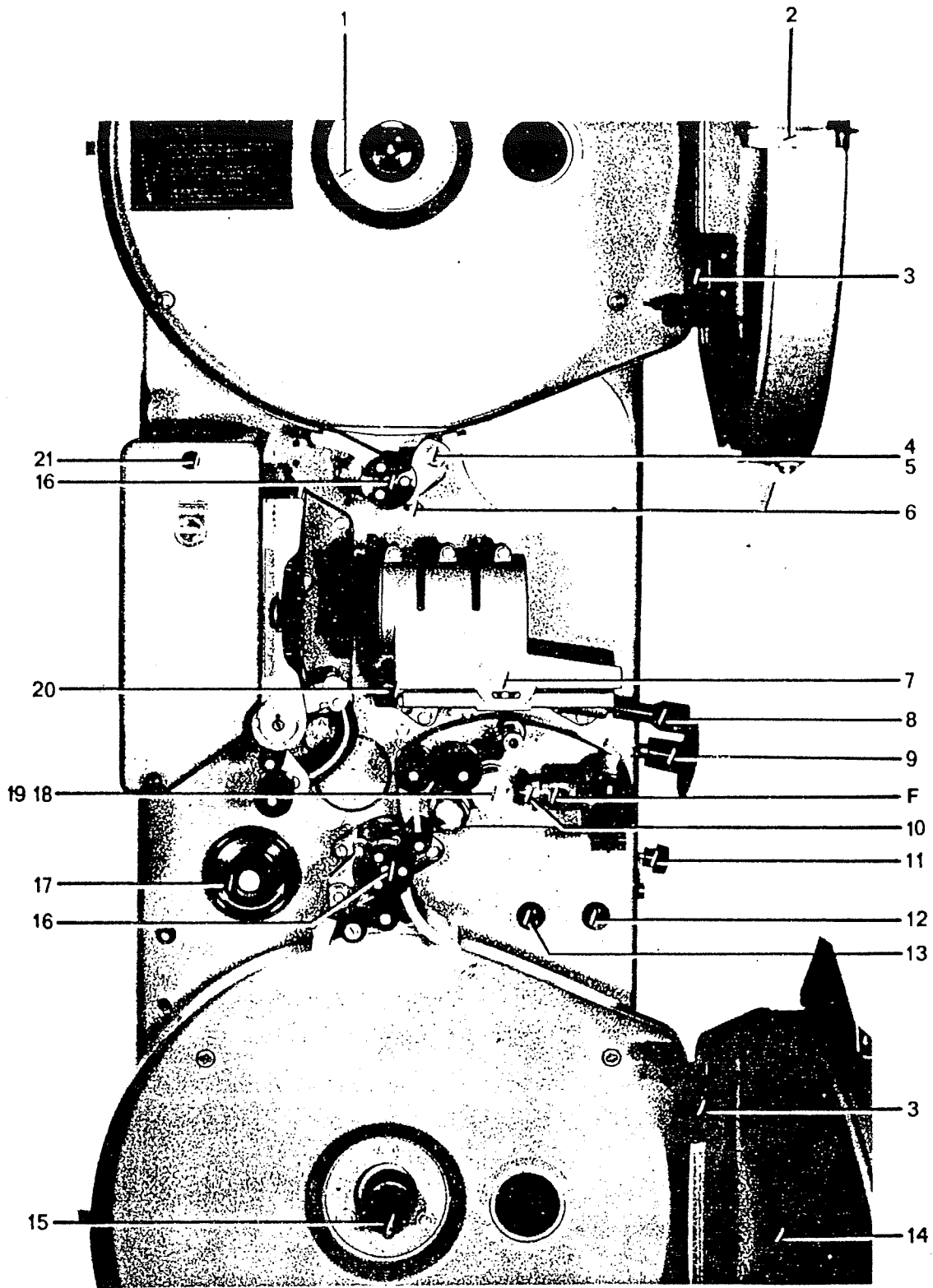

ERE 3039

Fig. 4

Item	Code Number	Description
1	4822 535 80184	Skate holder
2	4822 535 80089	Pin for lens mount
3	4822 404 50048	Lever for skate
4	4822 492 60122	Spring for skate adjustment
5	4822 492 40002	Resort for pressure roller
6	4822 404 50018	Lever for pressure roller
7	4822 525 60022	Pressure roller
	4822 520 20014	Ball bearing
	4822 530 70018	Snap ring
	4822 532 10094	Dust ring - Front
	4822 532 10168	Dust ring - Rear
8	4822 525 60096	Half flange roller
9	4822 255 20021	Exciter lampholder
10	4822 525 60095	Half guide roller
11	4822 462 70373	Cap
12	4822 266 30021	Socket for photocell
13	4822 404 50098	Support for glass rod
14	4822 381 10162	Glass rod
15	4822 462 70374	Cap
16	4822 502 10225	Adjusting screw
17	4822 522 30407	Sprocket shaft
18	4822 502 10304	Adjusting screw
19	4822 520 10025	Sprocket shaft bearing
20	4822 522 30119	Sprocket
21	4822 532 50362	Ceramic guide roller
22	4822 502 10336	Knurled nut
23	4822 451 10011	Aperture - Normal
	4822 451 10012	Aperture - W.S.
	4822 451 10009	Aperture - C.S.
	4822 451 10013	Aperture - Blank
24	4822 463 10019	Skate
25	4822 463 10021	Runner strip
25a	4822 463 10016	Runner strip - Special
26	4822 525 6007 <sup>95</sup>	Roller

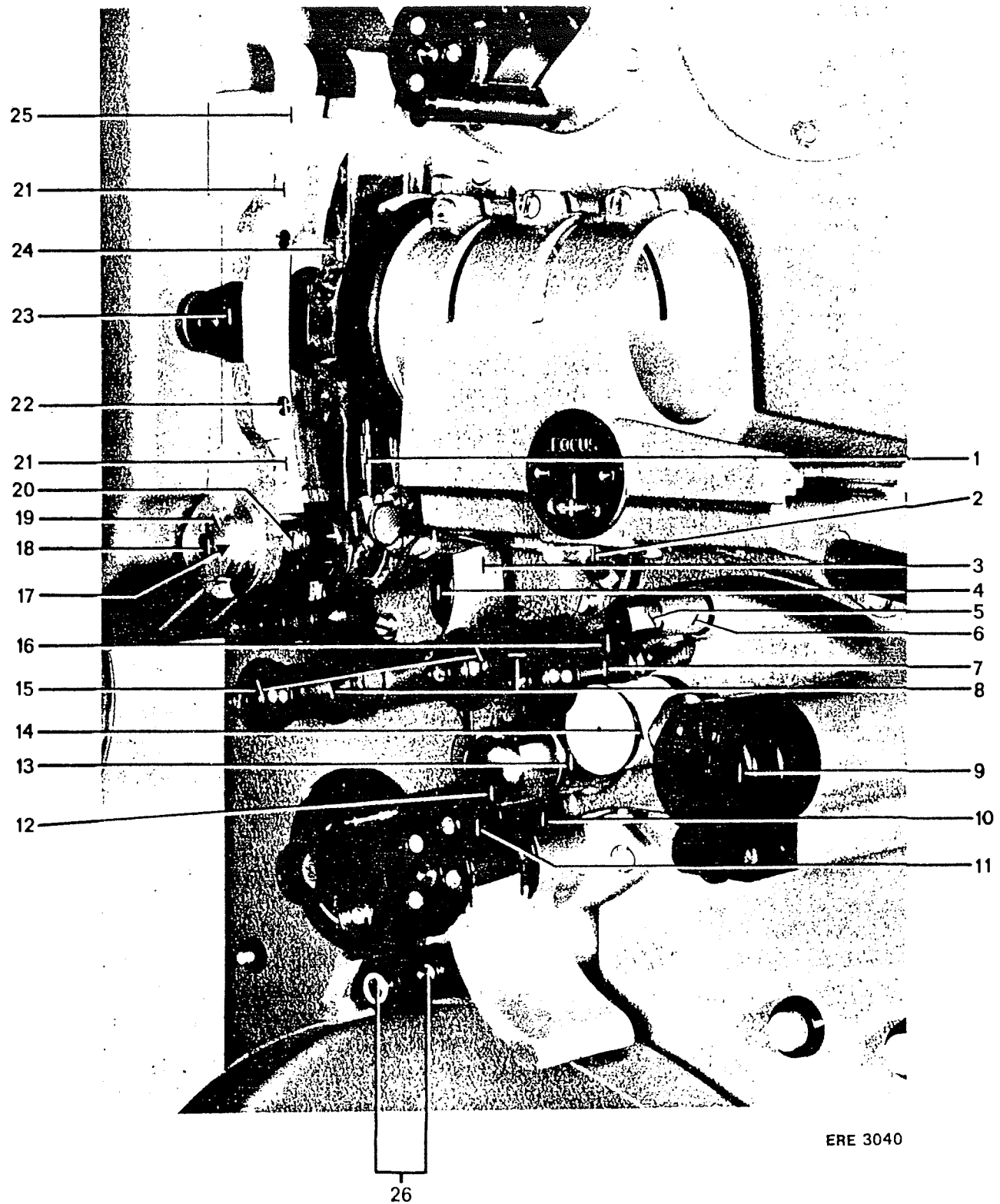
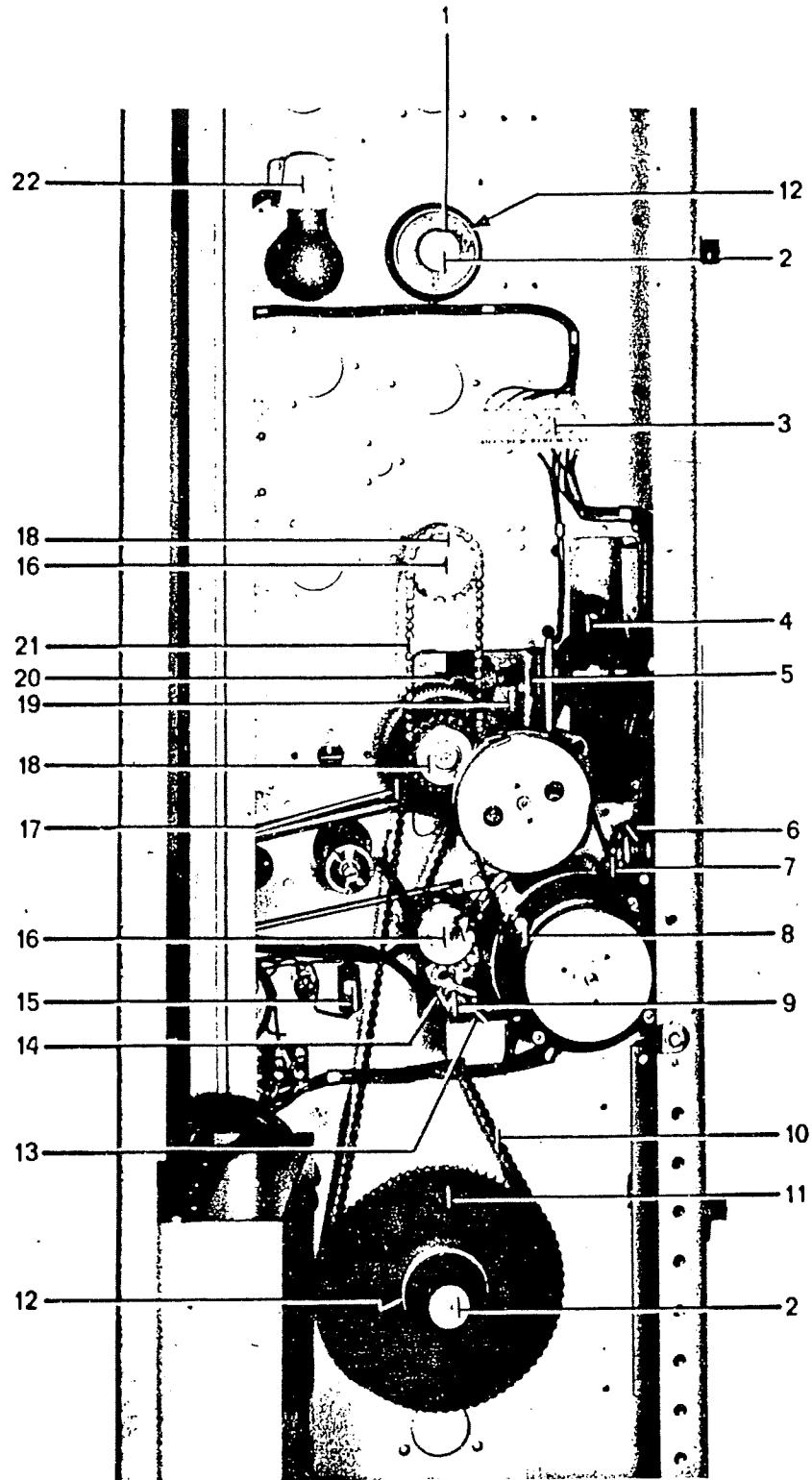

Fig. 5

Item	Code Number	Description
1	4822 528 20011	Upper friction (See Fig. 9)
2	4822 505 10049	Knurled nut
3	4822 290 60044	Terminal
4	4822 515 20015	Shutter
4a	4822 515 40057	Sutter for accelerated movement
4b	4822 525 40056	5-Blade shutter
5	4822 532 70114	Oil level pipe (FP-20S)
5a	4822 530 20236	Oil level pipe (LCB...)
6	4822 532 50001	Neoprene ring
7	4822 358 10035	V-Belt
7a	4822 358 20006	Timing belt
8	4822 361 50003	Motor
9	4822 492 60789	Spring for centrifugal switch
10	4822 358 50009	Chain - 3000 ft. magazines
10a	4822 358 50011	Chain - 6000 ft. magazines
11	4822 522 30105	Chain wheel - Normal
11a	4822 522 30913	Chain wheel - Special
12	4822 532 50028	Felt disc
13	4822 271 30008	Micro switch
14	4822 532 60293	Nylon bushing of centrifugal switch
15	4822 121 30003	Capacitor
16	4822 535 90485	Sprocket shaft
16a	4822 520 20032	Ball bearing of sprocket shaft
17	4822 522 30089	Gear wheel
18	4822 522 30088	Chain wheel
19	4822 525 20017	Intermittent movement
19a	4822 525 20002	Accelerated intermittent movement
19b	4822 525 20023	Accelerated intermittent movement with delayed shutter shaft
20	4822 535 50009	Shutter shaft
20a	4822 535 50052	Shutter shaft for intermittent No. 19b
20b	4822 520 20057	Ball bearing for shutter shaft
20c	4822 530 70021	Snap ring for No. 20b
20d	3922 836 09170	Shutter hub
20e	3922 836 09980	Locking nut for No. 20d
20f	3922 836 09990	Spring washer for No. 20e
21	4822 358 50007	Chain
22	4822 255 10061	Lamp Socket



ERE 3041

Fig. 6

Item	Code Number	Description
1	4822 277 10014	Switch
2	4822 256 30098	Fuse holder
2a	4822 253 30028	Fuse (974/V4000)
3	4822 281 60089	Relay coil (220V)
4	4822 252 20004	Temperature fuse
5	4822 146 20239	Transformer
6	4822 121 10268	Capacitor - 1 uF
7	4822 121 10261	Capacitor - 4 uF
8	4822 124 50012	Capacitor - 8 uF
9	4822 121 10191	Capacitor - 12 uF
10	4822 280 40106	Relay - 6V
	4822 281 60081	Relay coil - 6V
	4822 278 90214	Lower contacts
11	4822 120 50178	Capacity - 700V, 0.47 uF
12	4822 121 20028	Capacity - 1300 V, 4700 pF

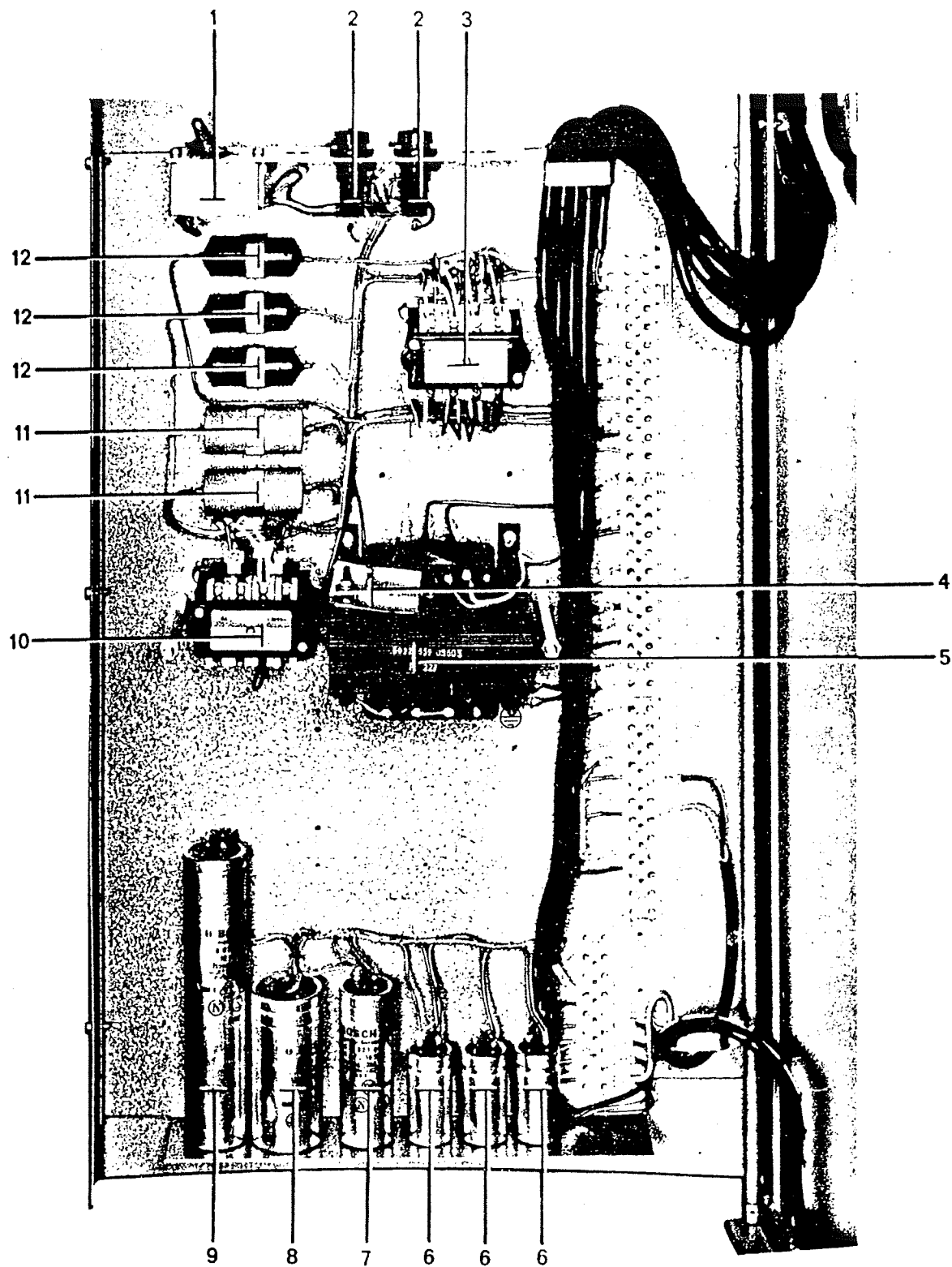

ERE 3042

Fig. 7



Item	Code Number	Description
1	4822 535 50033	Sound shaft
1a	4822 520 20003	Ball bearing for sound shaft
2	4822 310 20019	Cap
3	4822 525 60082	Half flange roller
4	4822 249 30016	Magnetic cluster
4a	4822 705 14375	Nu-metal shield for No. 4
5	4822 525 30003	Pad shoe
6	4822 522 30104	Sprocket
7	4822 404 50084	Film stripper
8	4822 492 40001	Spring
9	4822 462 50027	Tension nut
10	4822 525 60096	Half flange roller
11	4822 492 60114	Spring

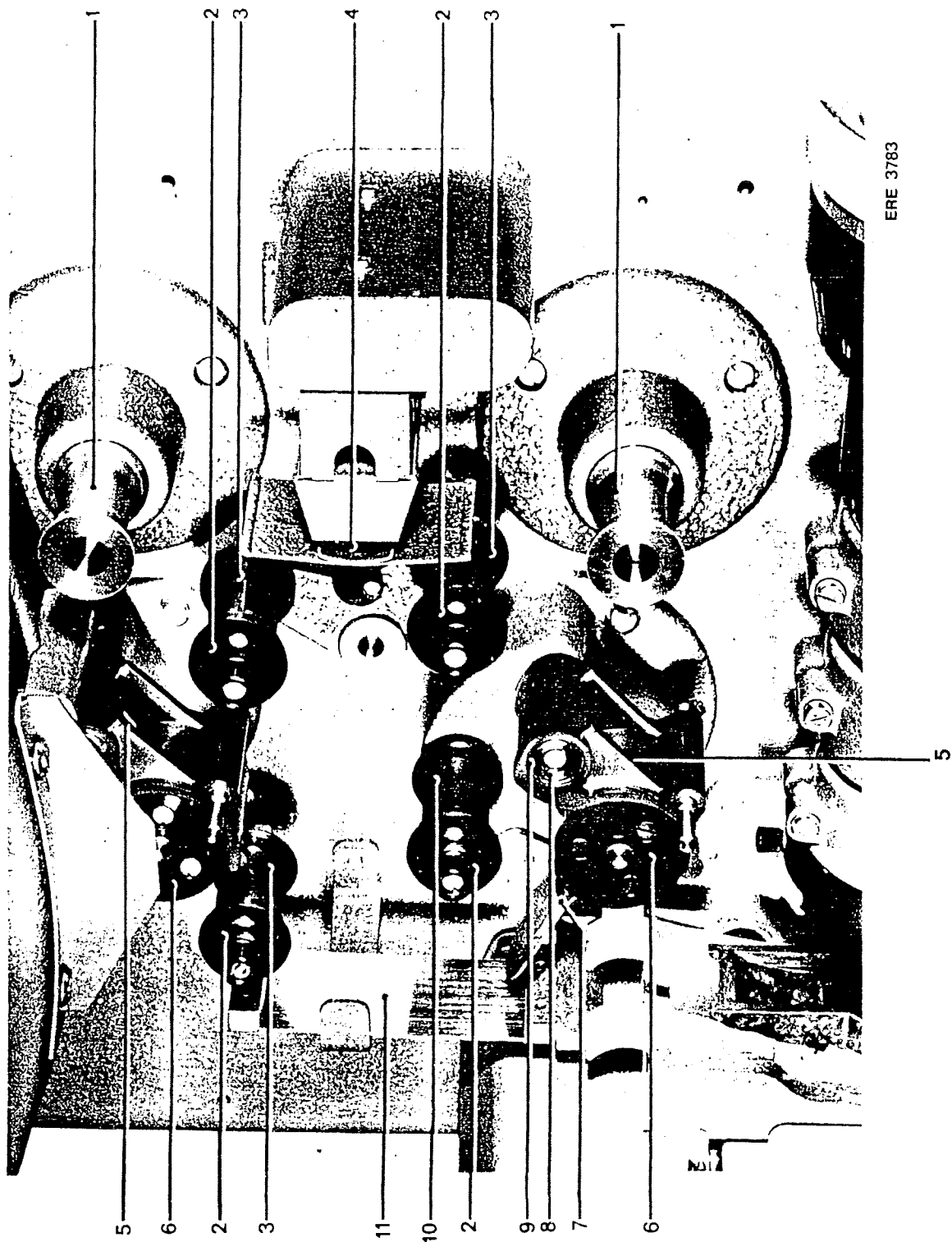

ERE 3783

Fig. 8

Item	Code Number	Description
1	4822 463 10021	Runner strip
2	4822 532 50362	Guide roller
3	4822 360 40048	Piston
4	4822 492 50076	Spring
5	4822 451 10011	Aperture plate- Normal
5a	4822 451 10009	Aperture plate- C.S.
5b	4822 451 10012	Aperture plate- W.S. (1:1.85)
5c	4822 451 10015	Aperture plate - W.S. (1:1.75)
5d	4822 451 10013	Aperture plate- Blank
6	4822 520 10025	Bearing
7	4822 502 10304	Adjusting screw
8	4822 502 10273	Fixing screw
9	4822 522 30407	Intermittent sprocket shaft (Old Version)
9a	4822 522 30947	Intermittent sprocket shaft (New Version)
10	4822 522 30119	Intermittent sprocket
11	4822 532 40006	Ring (Old Version)
11a	4822 530 50427	Ring (New Version)
12	4822 530 50097	Ring
13	4822 529 50058	Tension pin
14	2622 080 21022	Ring
15	4822 525 60074	Coupling bushing
16	4822 492 61368	Spring
17	4822 532 40006	Ring
18	2622 080 21032	Ring
19	4822 522 30824	Coupling shaft
20	4822 522 30089	Toothed wheel
21	4822 522 30088	Chain wheel
22	4822 520 20057	Ball bearing
23	4822 530 50147	Ring
24	4822 505 10049	Knurled nut
25	4822 492 50064	Spring
26	4822 532 10499	Metal disc
27	4822 532 50028	Felt disc
28	4822 530 70021	Circlip
29	4822 520 20032	Ball bearing
30	4822 693 50013	Spoolshaft
31	4822 522 30105	Chain wheel
32	4822 693 50068	Spoolshaft
33	4822 530 70021	Circlip
34	4822 520 20032	Ball bearing

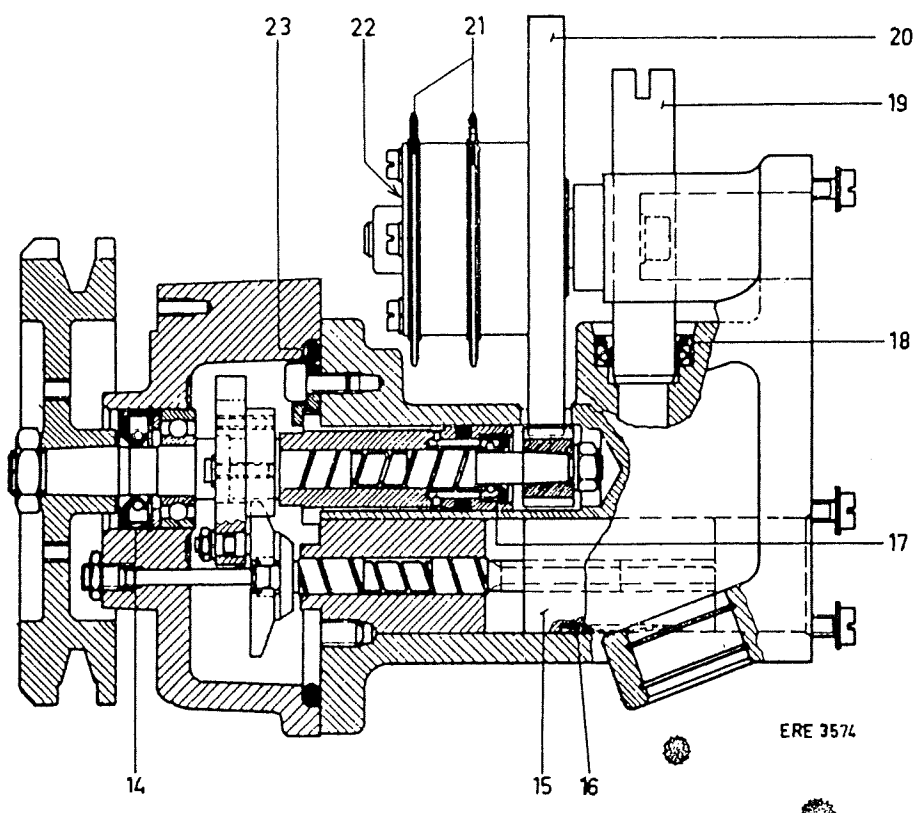
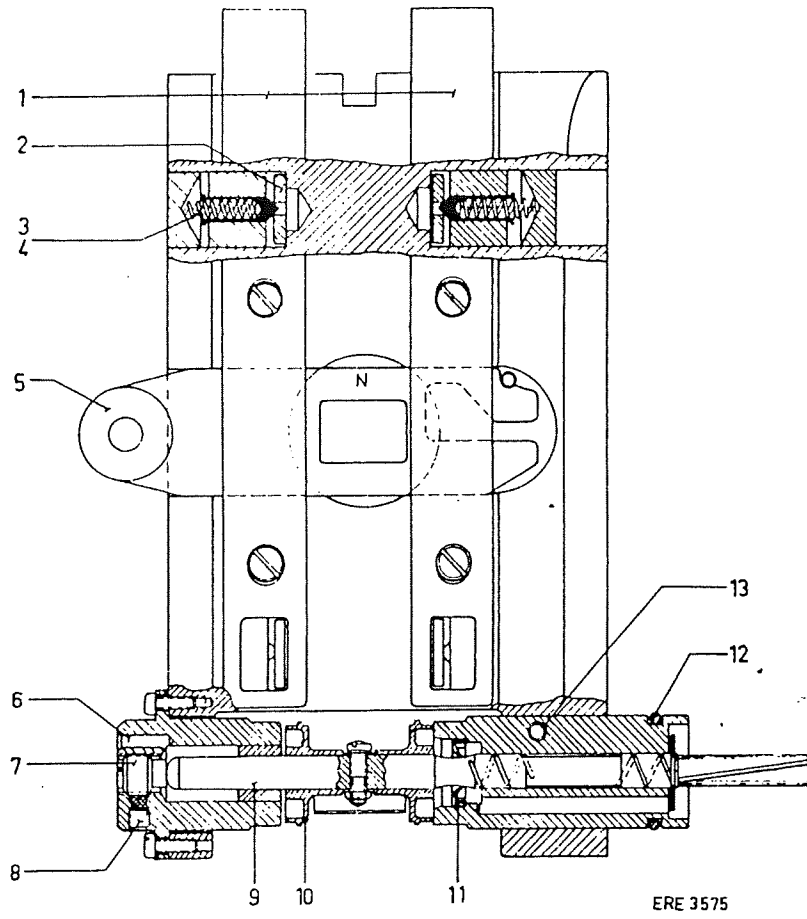

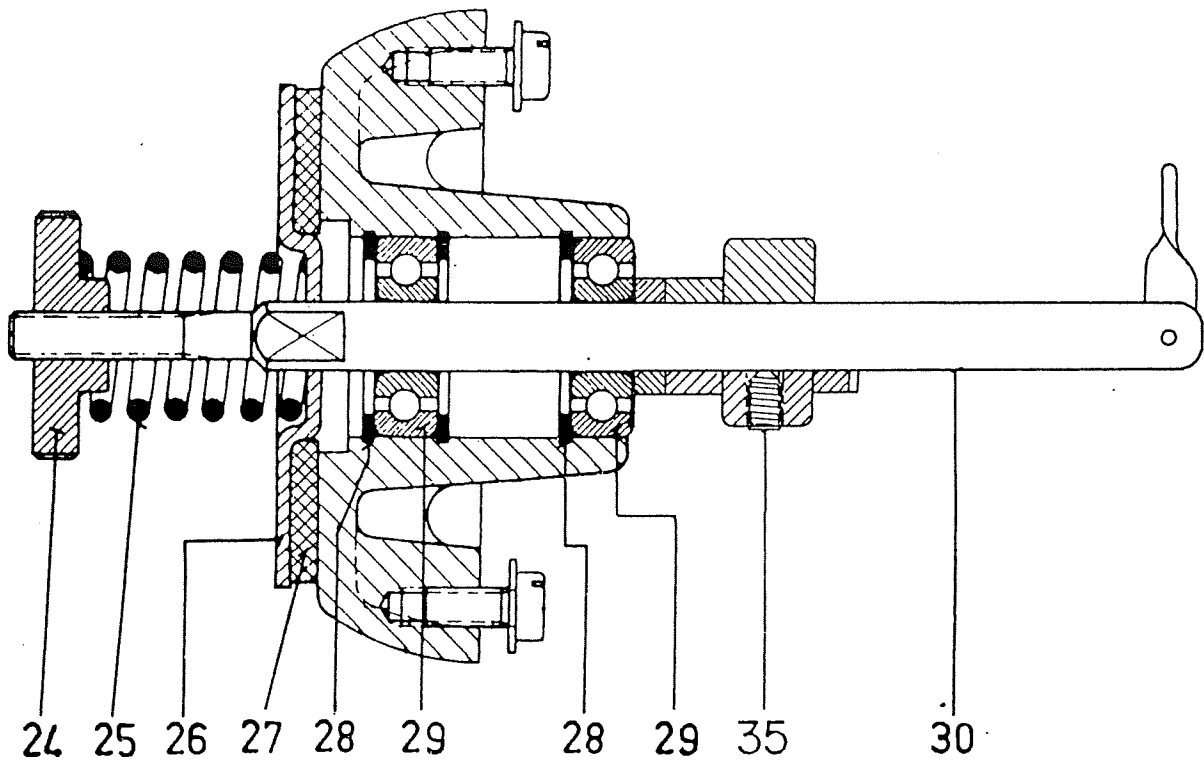

ERE 3573

Fig. 9c

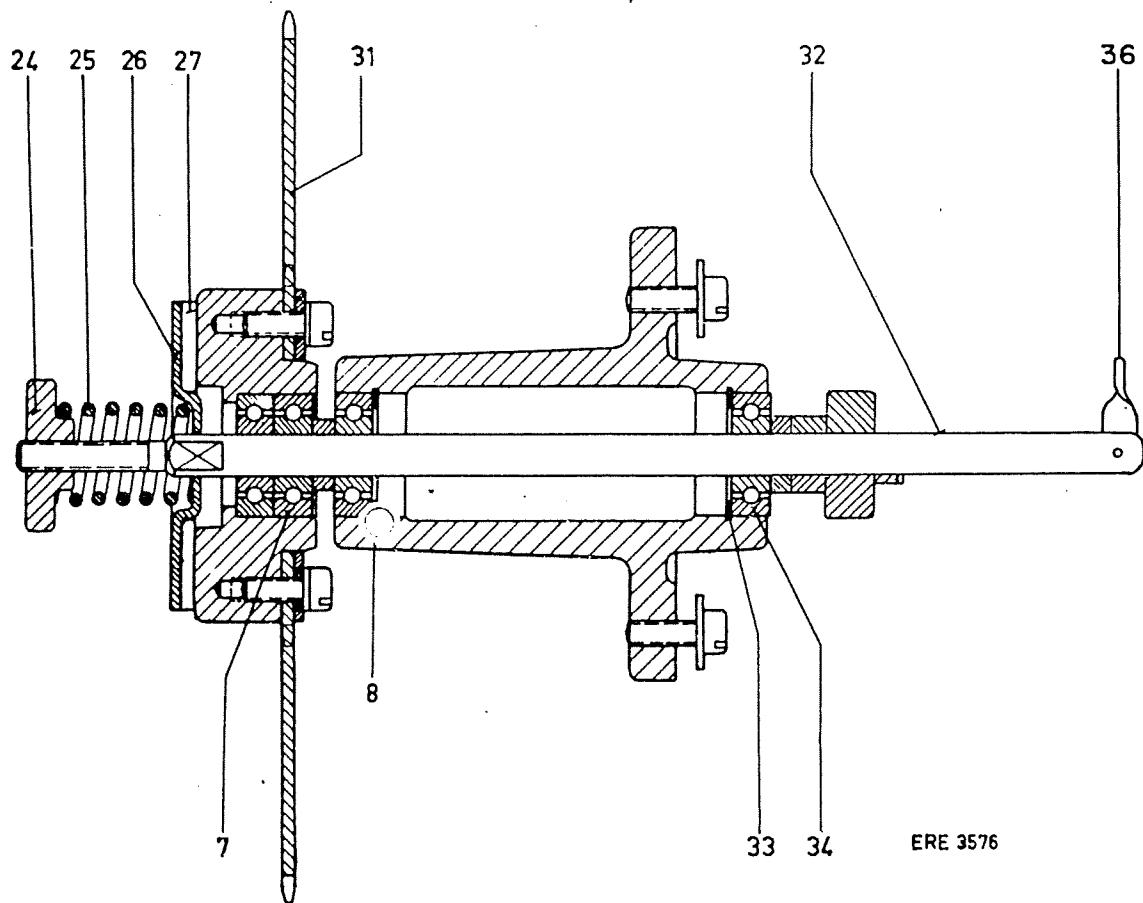

ERE 3576

Fig. 9d

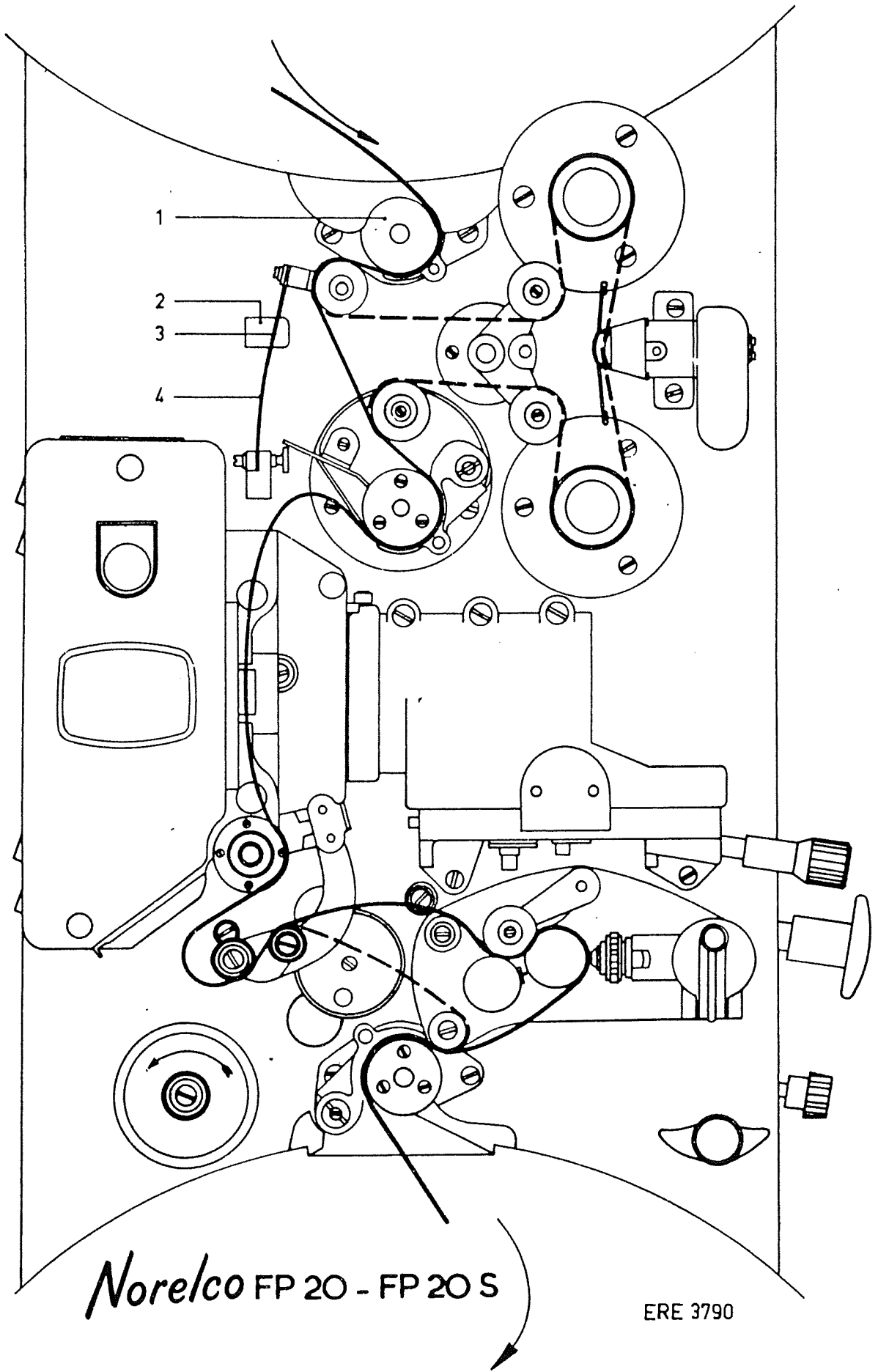
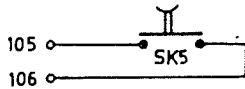
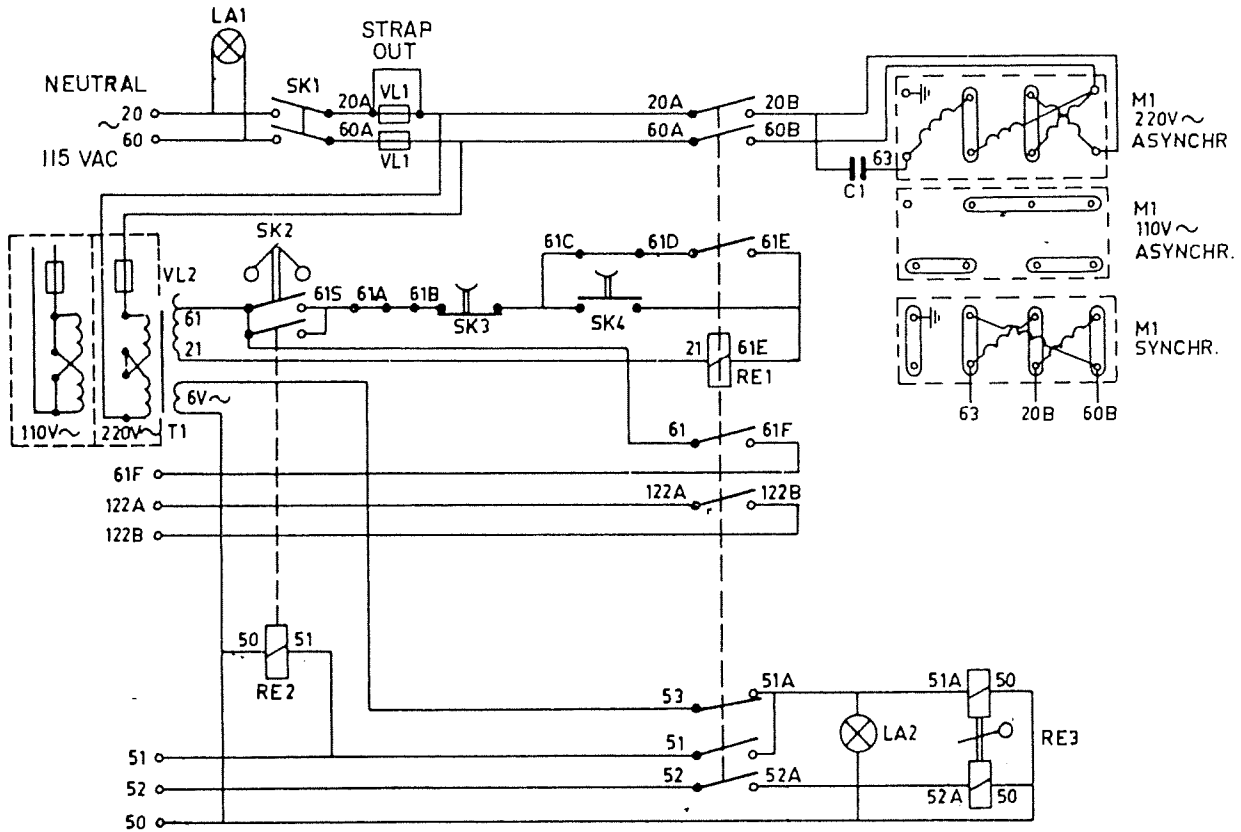
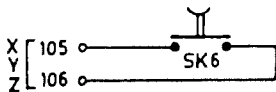

Fig. 10

LCB 0020



SOUND MUTE



SOUND CHANGE OVER

ERE 3731

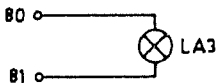

EXCITER LAMP

Fig. 11

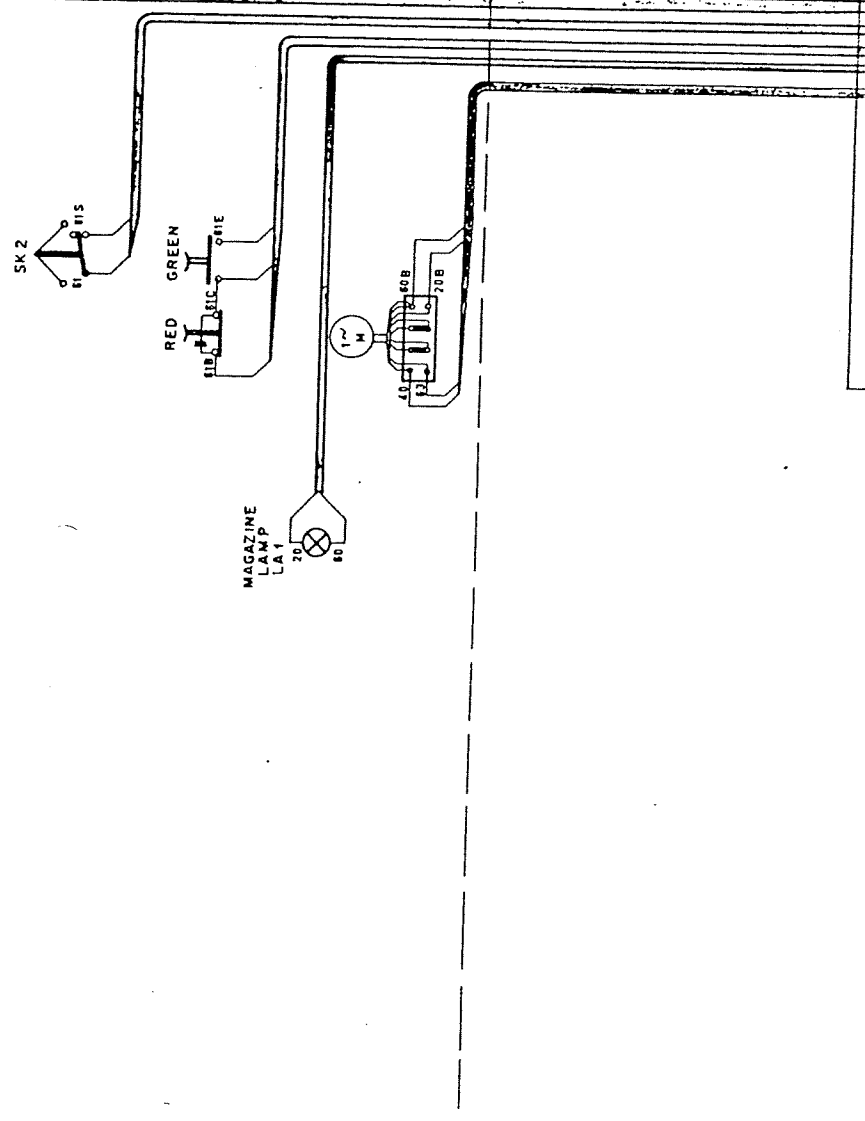
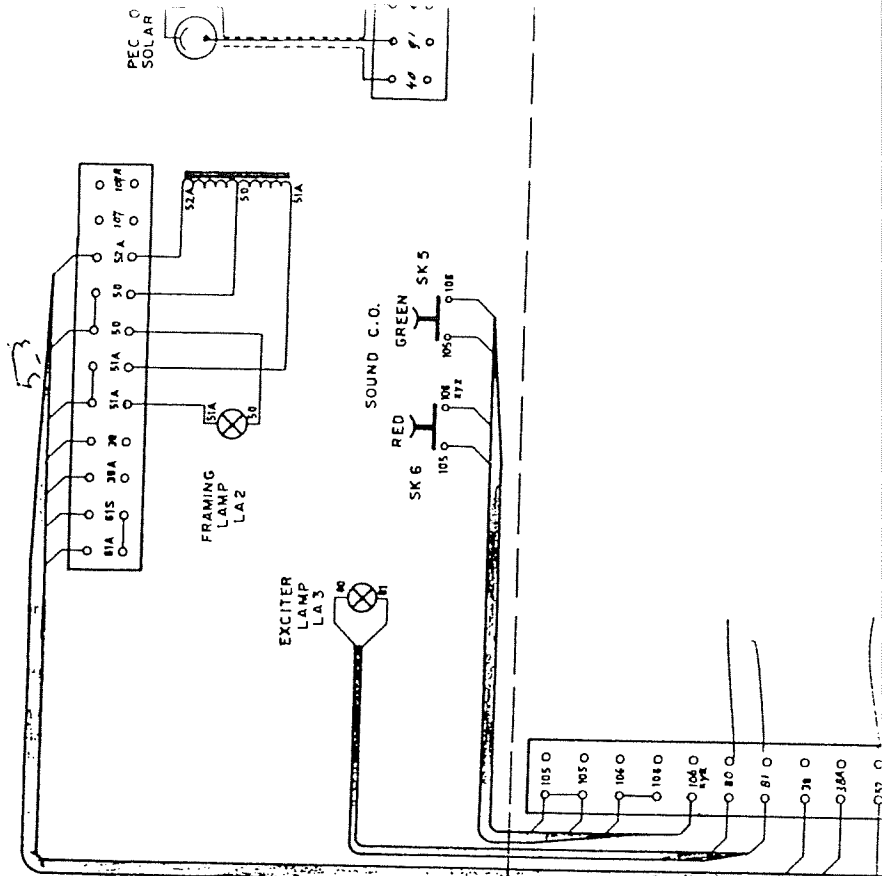



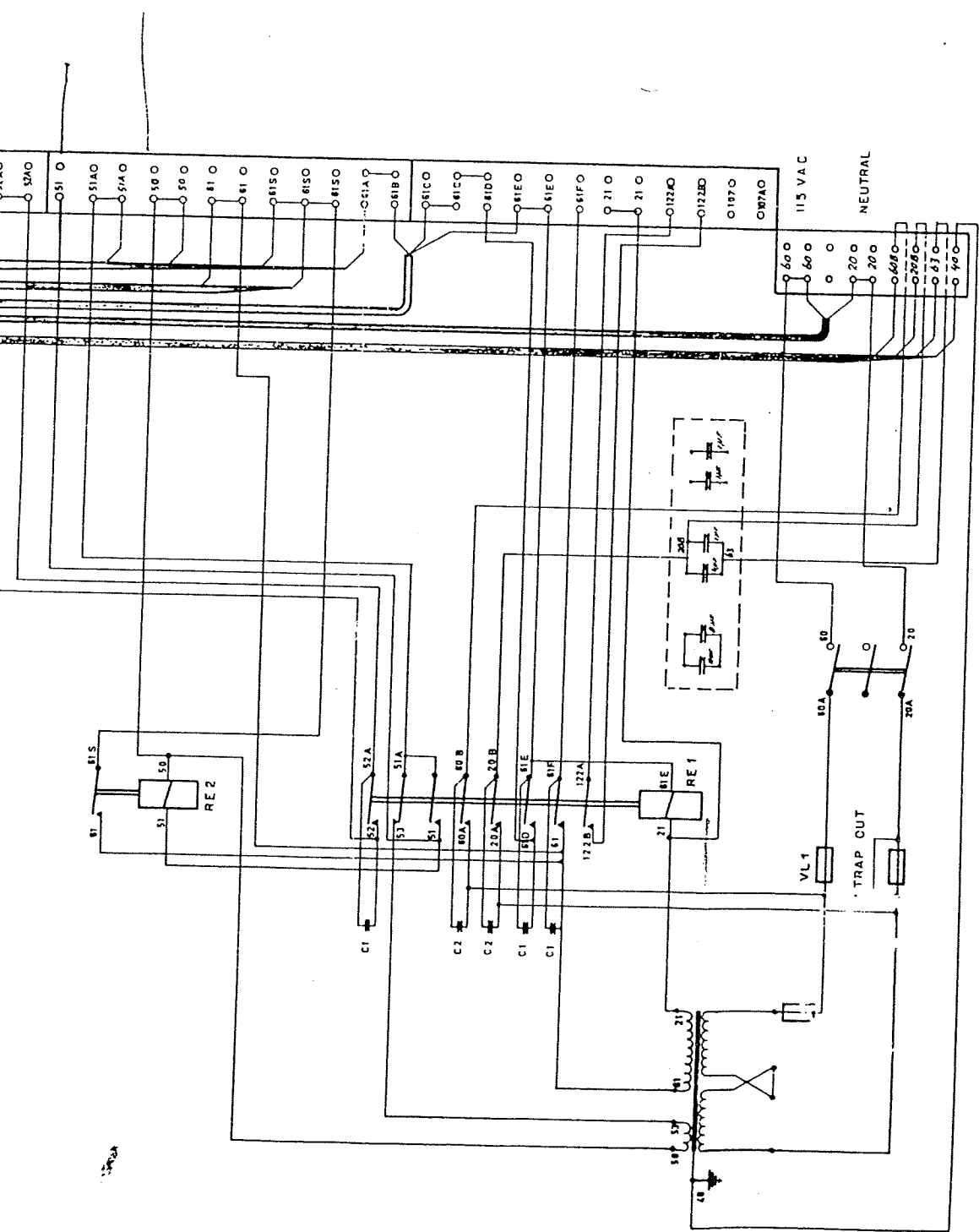

LCB 0020  
PROJECTOR

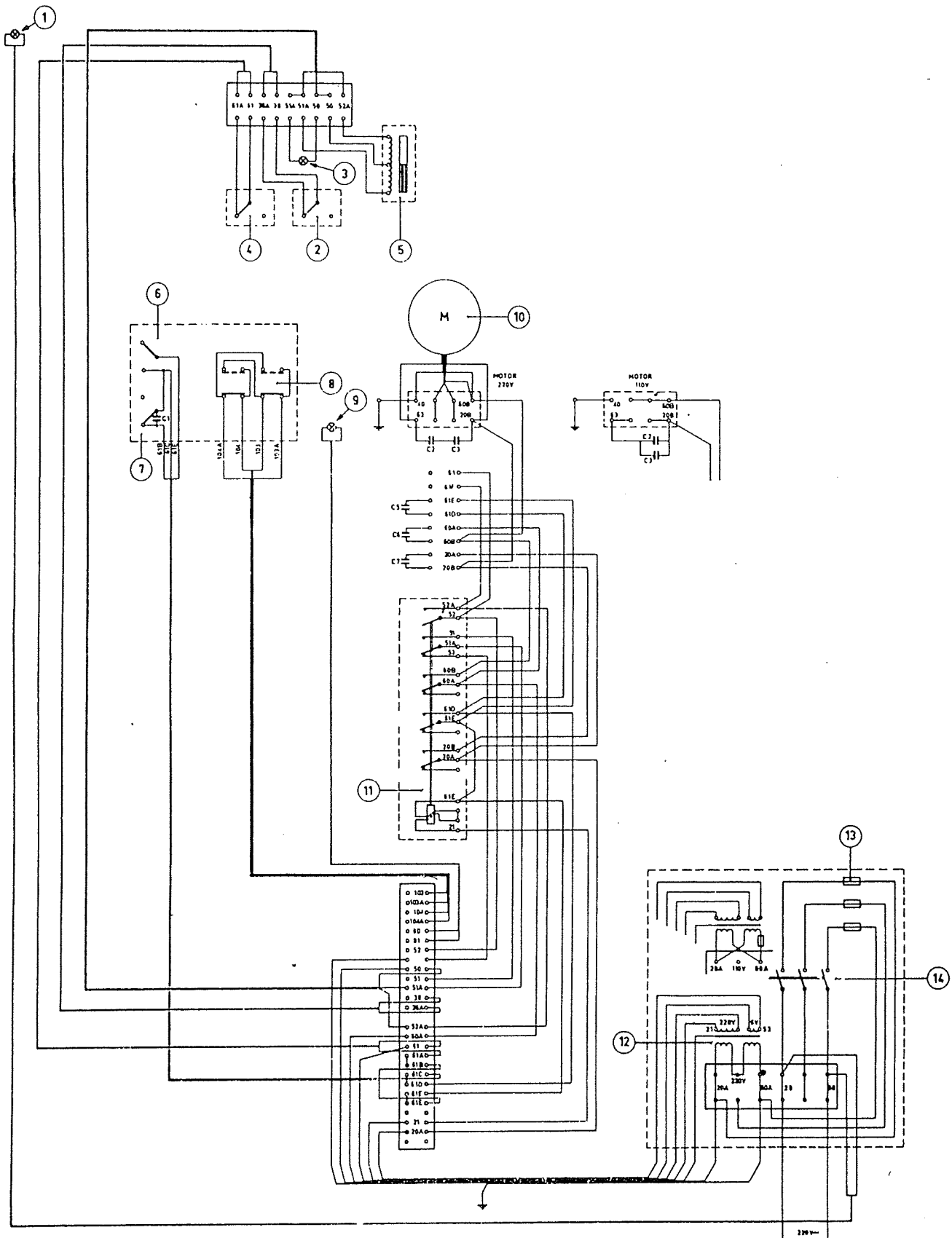
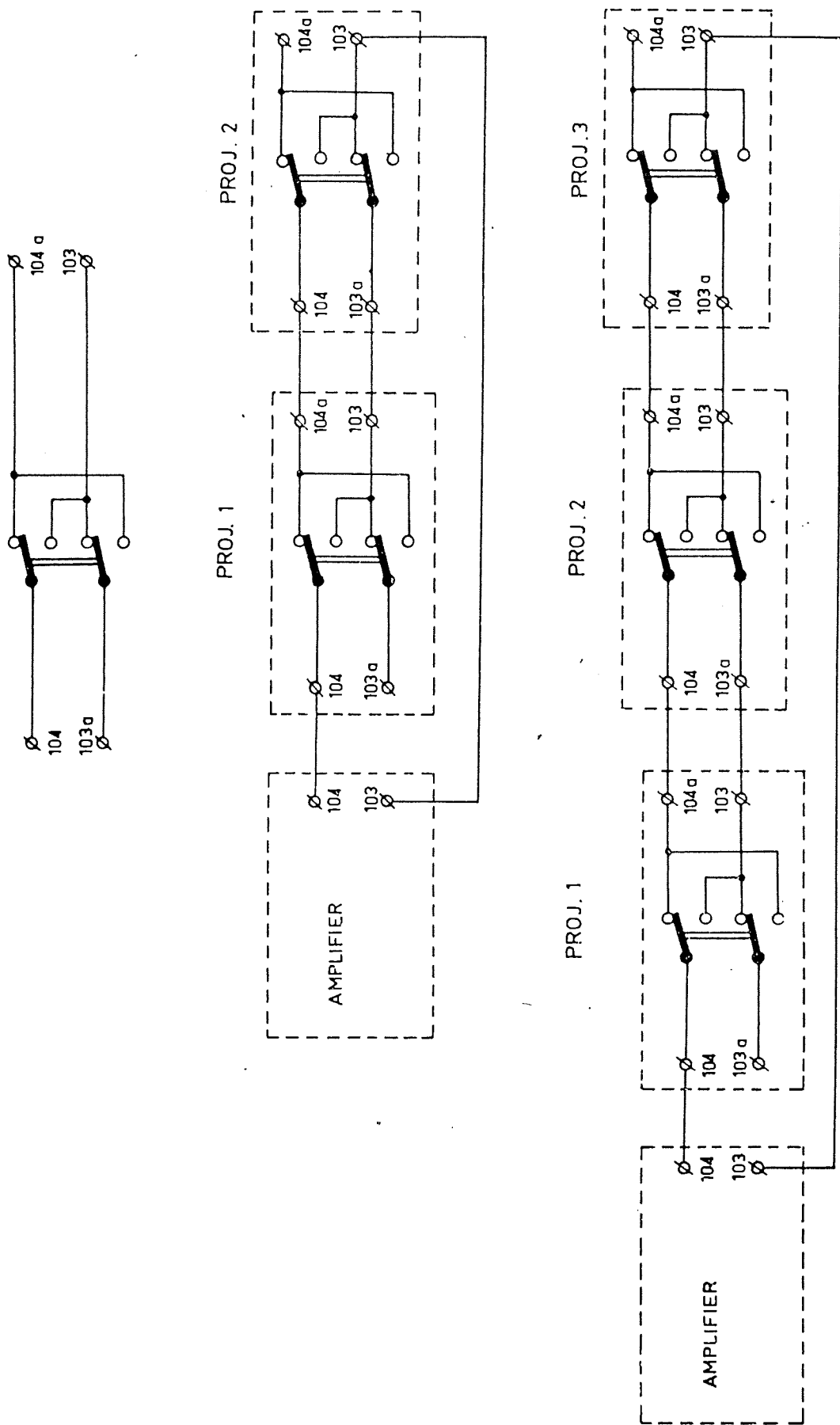

Fig. 13

ERE3792



ERE 3791

Fig. 14

LAMPHOUSE - EL 4475

The lamphouse, for 1000W, 120V incandescent lamp type 7240C, is provided with a spare lamp which can be put into operation during projection by means of a lever at the bottom of the lamphouse.

When the lamp is in its operating position, the lamp holder is locked by a ball and pressure spring. A stop pin prevents excessive travel.

In the factory, the lamphouse has been aligned with respect to the projector's optical centerline. The lamphouse is then dowelled and fixed with the three screws F (Fig. 15).

If the line voltage is 120V, the lamphouse can be connected direct to the mains. (Fig. 20)

-Connect terminals 50-52A to those on projector (6V circuit).

Depending on the position of micro-switch S1, either relay RE1 or RE2 is energized and projection lamp LA1 or LA2 is ignited. The micro-switch is operated by the lamp changeover lever.

NOTE: The fan is supplied from the projector control transformer (21-61E).

#### Replacement and adjustment of the mirror (Fig. 15)

- Remove the two lamps and disconnect the electrical connections of both lamp holders.
- Loosen screws A and remove the caps of the lamp holders.
- Loosen screws B and remove the heat screens.
- Loosen screws C and remove the mirror.
- Mount the new mirror, and adjust the distance between mirror and front face of the lamp holder according to Fig. 17.

It is also possible to use a gauge as shown in Fig. 22.

#### Mounting the other components

- In reverse order.

#### Replacement of the condenser lenses (Fig. 17)

- Loosen screws A (Fig. 15) and remove the cap of the lamp holder.
- Loosen the four screws E (Fig. 15) and remove the lens holder.

The lenses can now be replaced.

#### Alignment of the lamphouse

The optical axis of the condenser lens must be in line with that of the projection lens.

#### Adjustment:

- Remove the heat screen, the aperture plate and the pressure skate from the projector.
- Remove the projection lens and insert a sleeve as shown in Fig. 21, into the lens holder.
- Insert a shaft (Fig. 21) into the sleeve and at its end facing the lamphouse mount a ring (Fig. 21).

Keep the tolerance between the shaft and the bore in the sleeve as small as possible.

NOTE:

The outer diameter of the ring equals that of the condenser lens holder.

- Position the lampholder until the ring coincides with the condenser-lens holder.
- Remove the tools.
- Mount the lamphouse and dowel it.
- Mount the pressure skate, the aperture plate and the light cut-off screen.

Alignment of the lamp

- Turn on the lamp with the projector running and centrifugal switch blocked open.
- Loosen the four screws D (Fig. 15) of the lamp holder and position the latter so that the light distribution on the screen is as uniform as possible. Make certain that the lamp is as close as possible to the condenser lens. If the desired result cannot be achieved with this adjustment, turn the mirror slightly.
- Tighten the four screws D of the lamp holder.

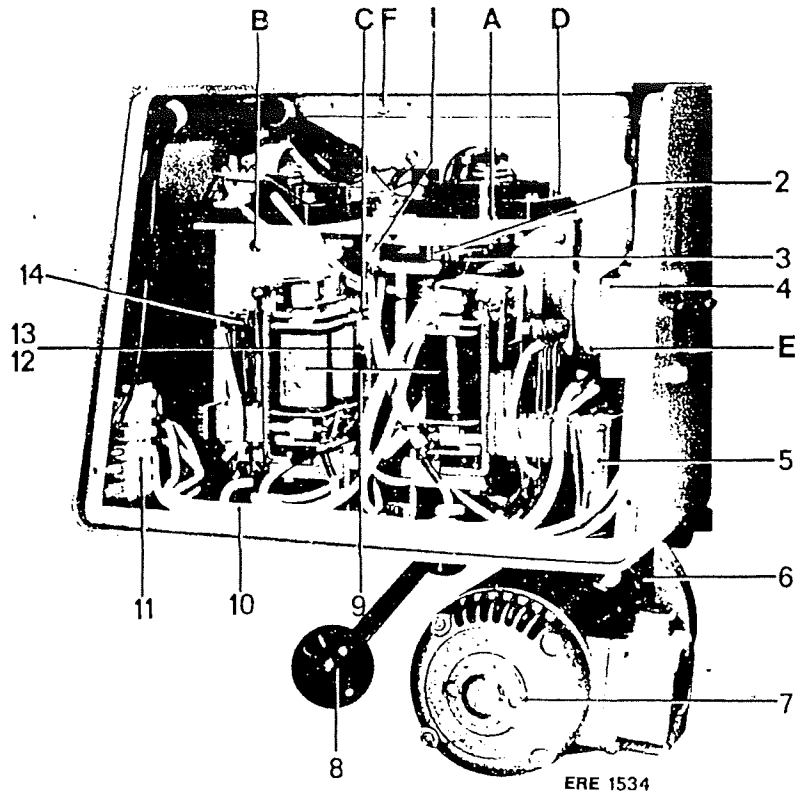

Fig. 15

Item	Code Number	Description
1	4822 520 40013	Bali
2	4822 529 50049	Tension pin
3	4822 271 30008	Micro switch
4	4822 277 10014	Switch
5	4822 121 10134,	Capacitor
6	4822 323 30003	Cable
7	4822 361 50028	Motor
8	4822 413 90002	Knob
9	4822 280 80255	Relay
10	4822 323 20036	Asbestos cable
11	4822 290 60044	Terminal
12	4822 492 60005	Spring
13	4822 380 20011	Mirror
14	4822 278 90177	Contact

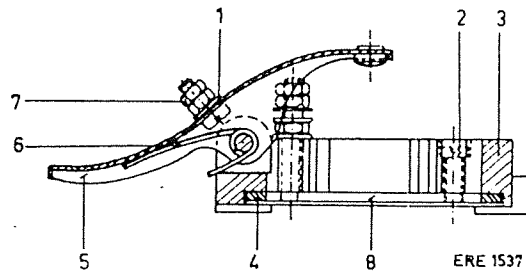

Fig. 16

Item	Code Number	Description
1	4822 532 10202	Washer
2	4822 502 10232	Screw
3	4822 693 50053	Support
4		
5	4822 404 50006	Lever
6	4822 492 40004	Spring
7	4822 505 10006	Nut
8	4822 050 00213	Contact ring

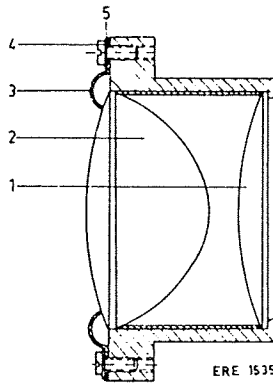

Fig. 17

Item	Code Number	Description
1	4822 381 40013	Condensor lens
2	4822 381 80008	Asf. condensor lens
3	4822 492 60004	Spring
4	4822 502 10096	Screw
5	4822 532 10202	Washer



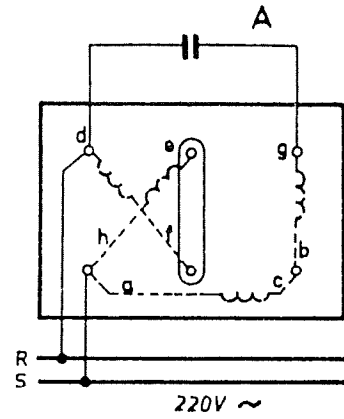
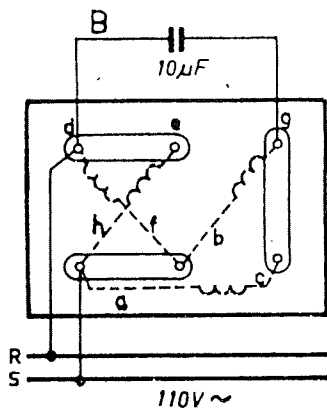
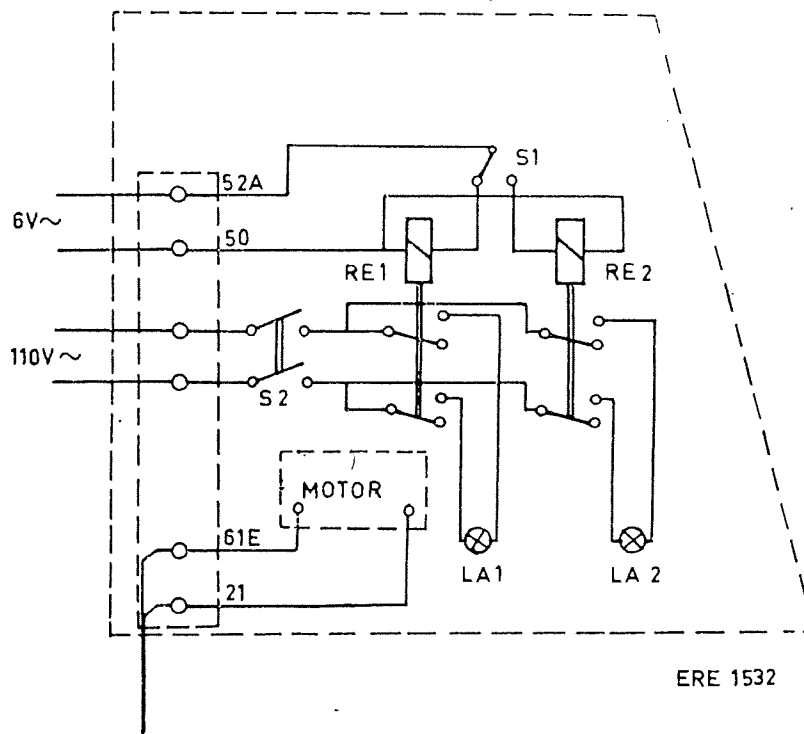

Fig. 18

ERE1796

- a - green
- b - blue
- c - yellow
- d - black
- e - grey
- f - brown
- g - white
- h - red



ERE 1532

Fig. 19

# LCB 0015

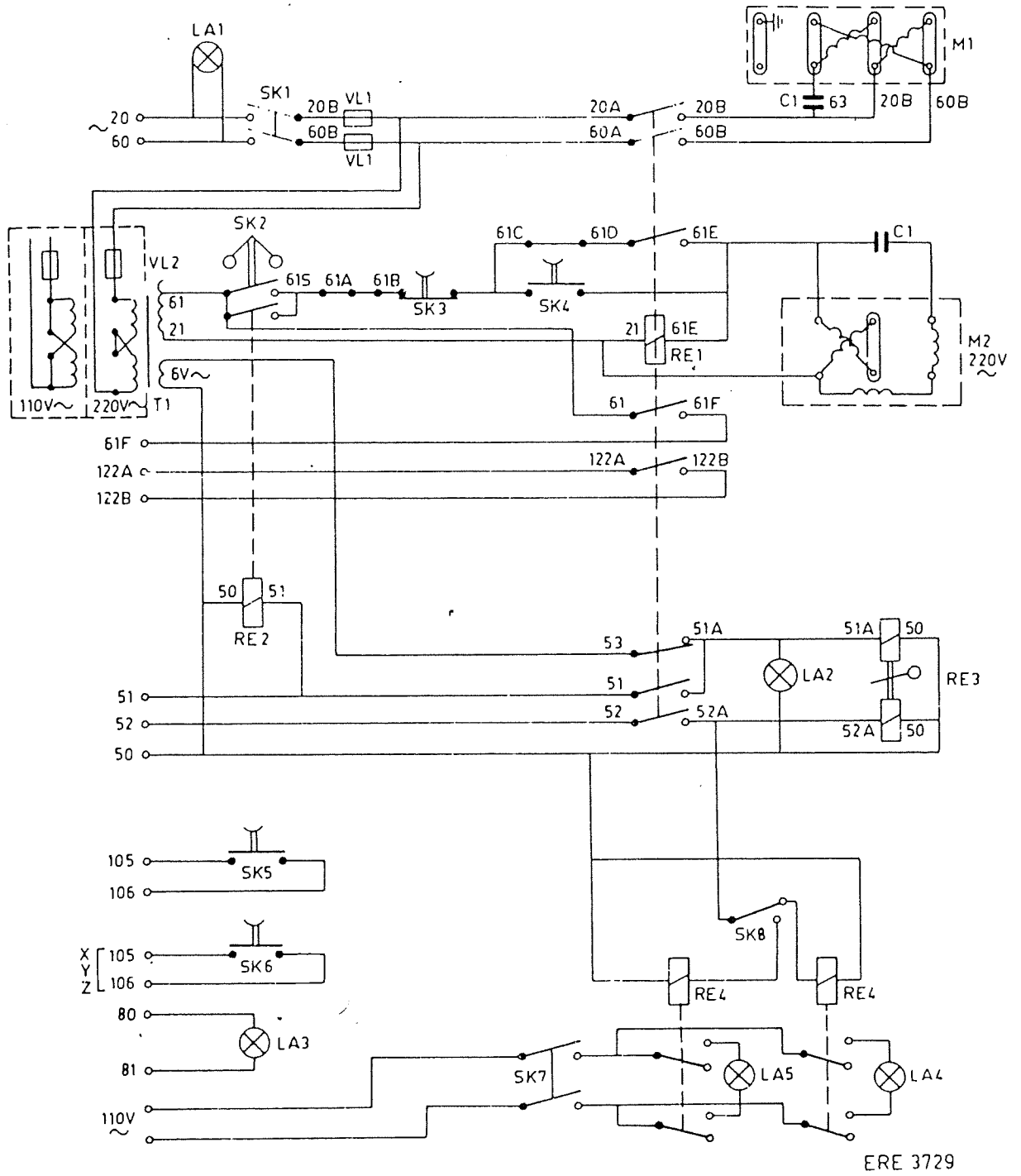
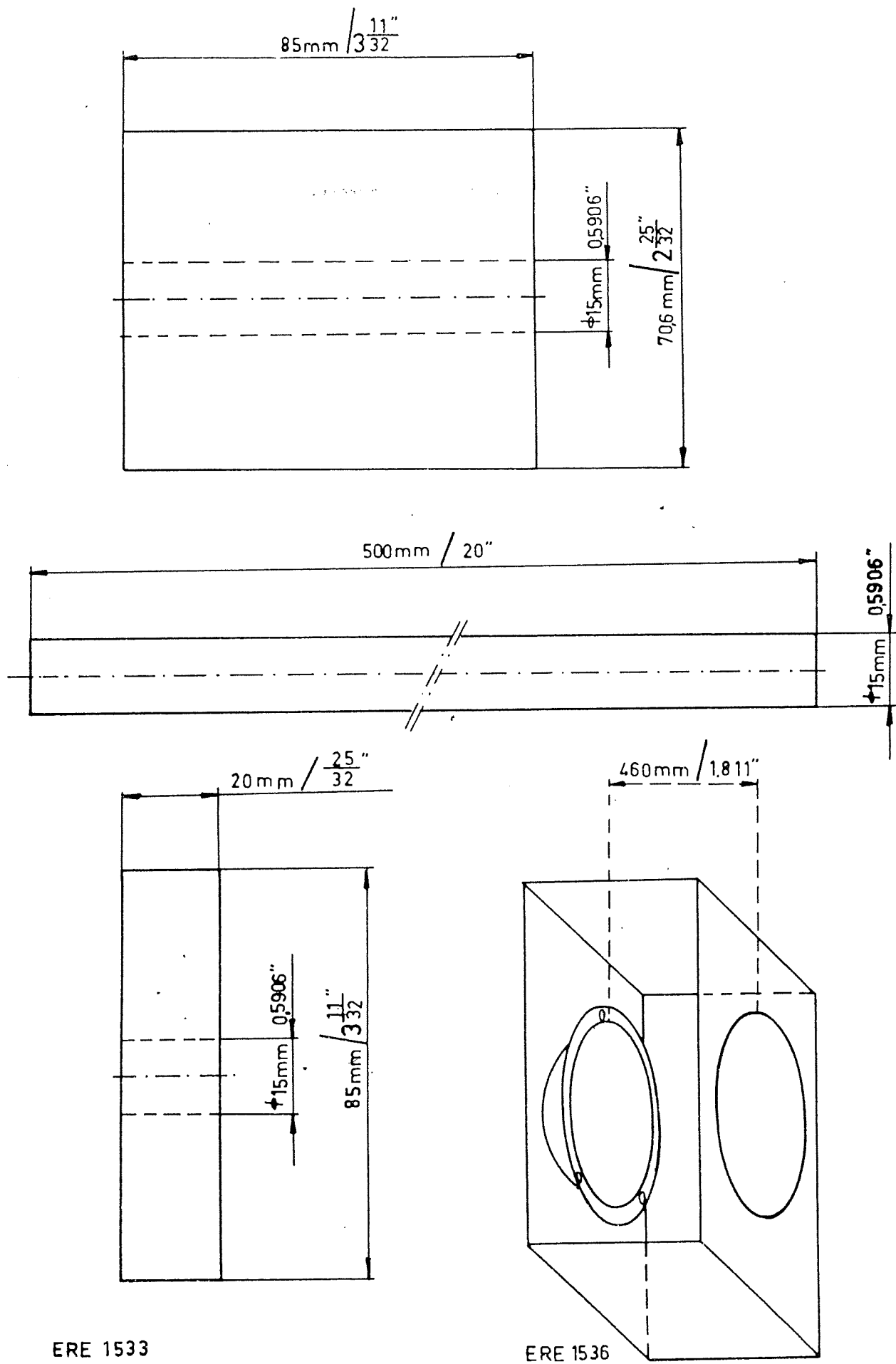

Fig.20



ERE 1533

ERE 1536

Fig. 21

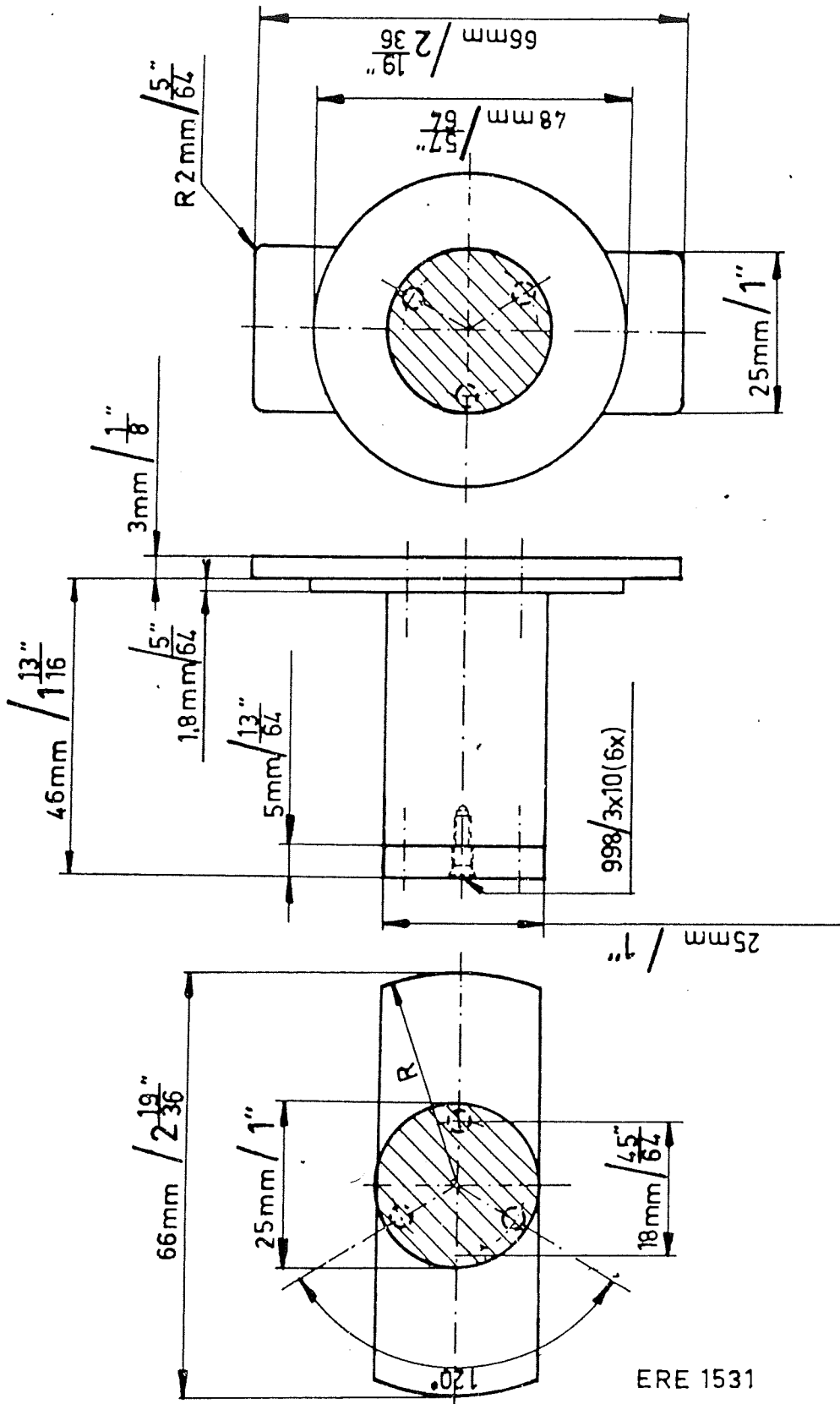

ERE 1531

Fig. 22

UNIVERSAL PROJ. CONTROL UNIT  
C-2443-2

MAGNA-TECH ELECTRONIC CO., INC.  
630 NINTH AVE., NEW YORK 36, N.Y.

DRAWN BY ERD

APPROVED BY

SCALE

~

USED ON

PJ-35 AS

MASTER DISTRIBUTOR

TITLE

FWD/INT/REV & RUN/STOP CONTROLS

DATE

3-27-66

DRAWING NUMBER

A-2783

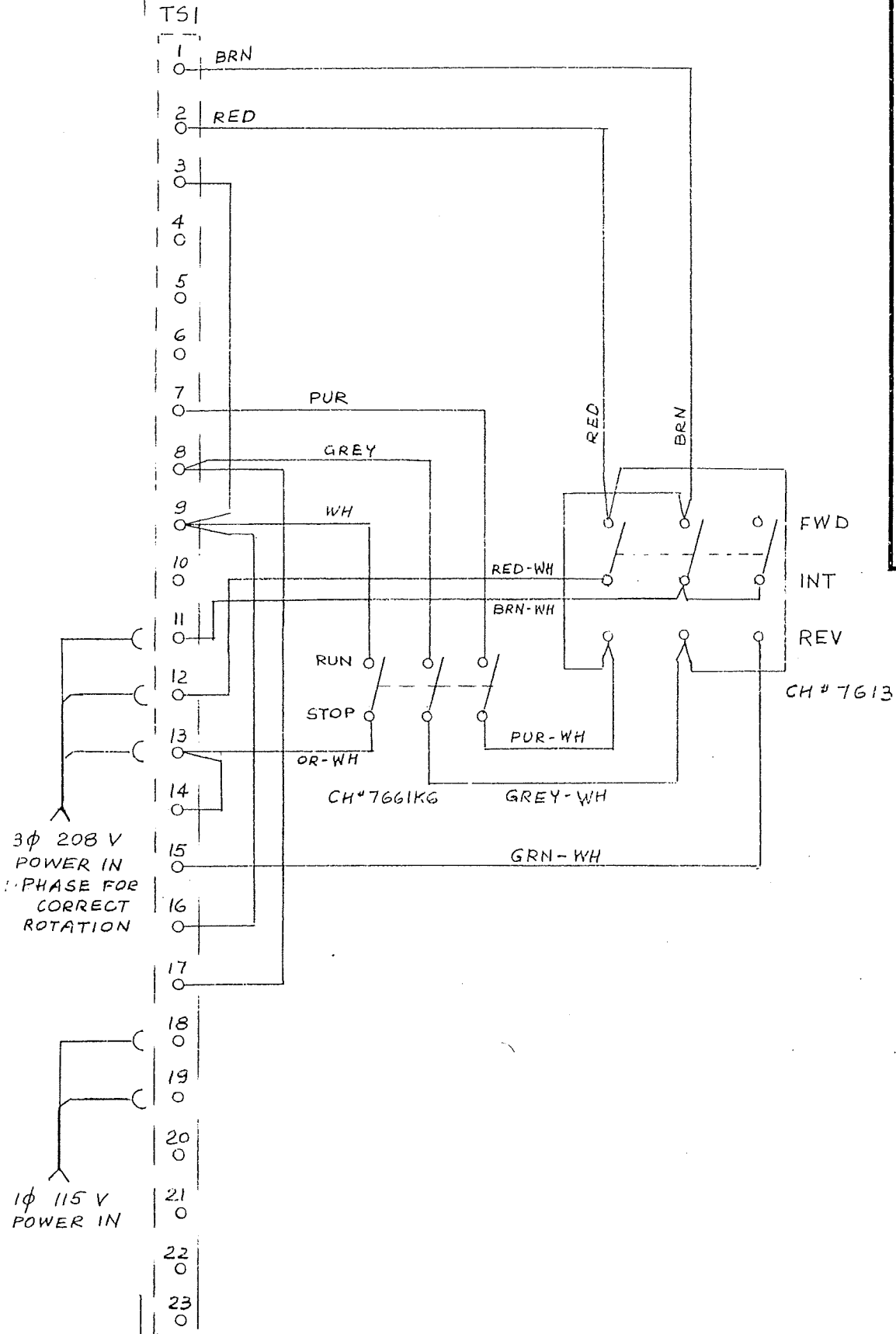

DATE SYM	REVISION RECORD	AUTH. DR. CK.

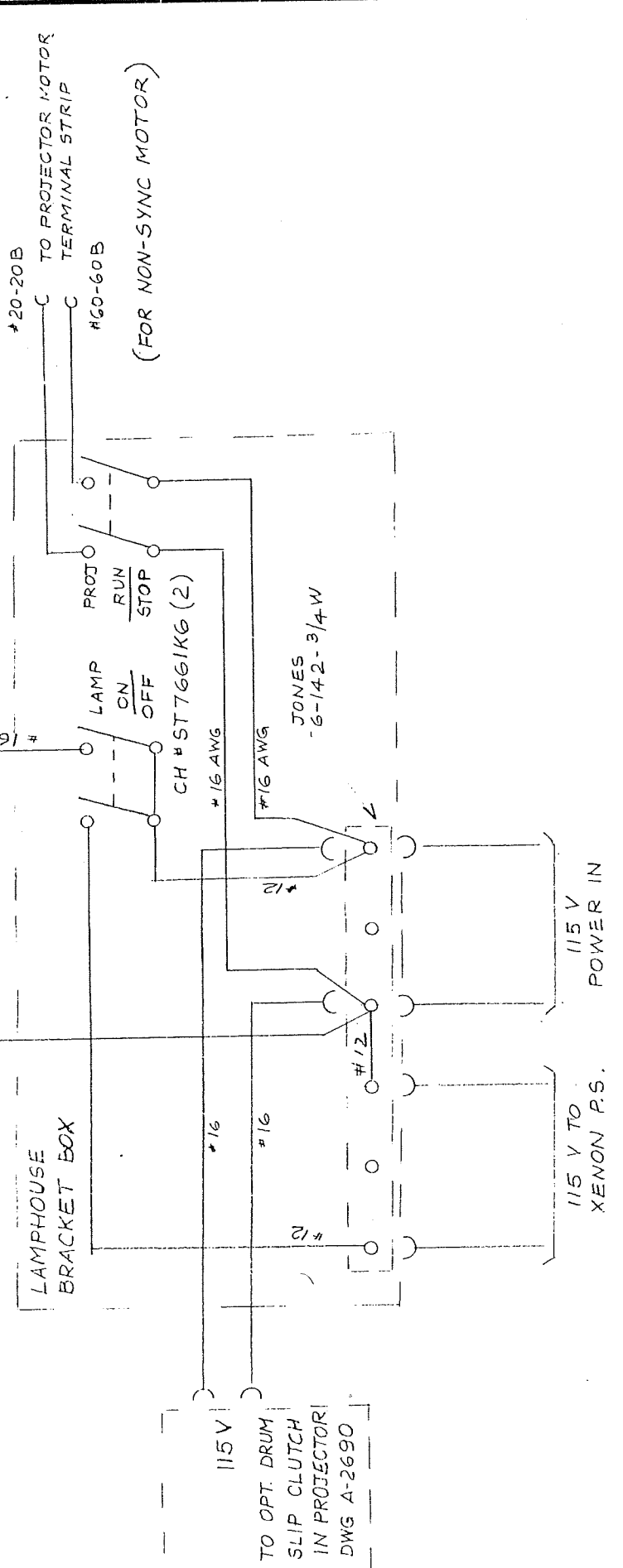

TOLERANCES (EXCEPT AS NOTED)		MAGNA-TECH ELECTRONIC CO., INC. 630 NINTH AVENUE, NEW YORK 36, N.Y.	
DECIMAL	±	USED ON PJ - 35	SCALE ~
FRACTIONAL	±	DRAWN BY <u>ER-DDS</u> APPROVED BY	
ANGULAR	±	TITLE CX - 450 LAMPHOUSE AC WIRING	
DATE 4 - 8 - 66		DRAWING NUMBER A-2793	



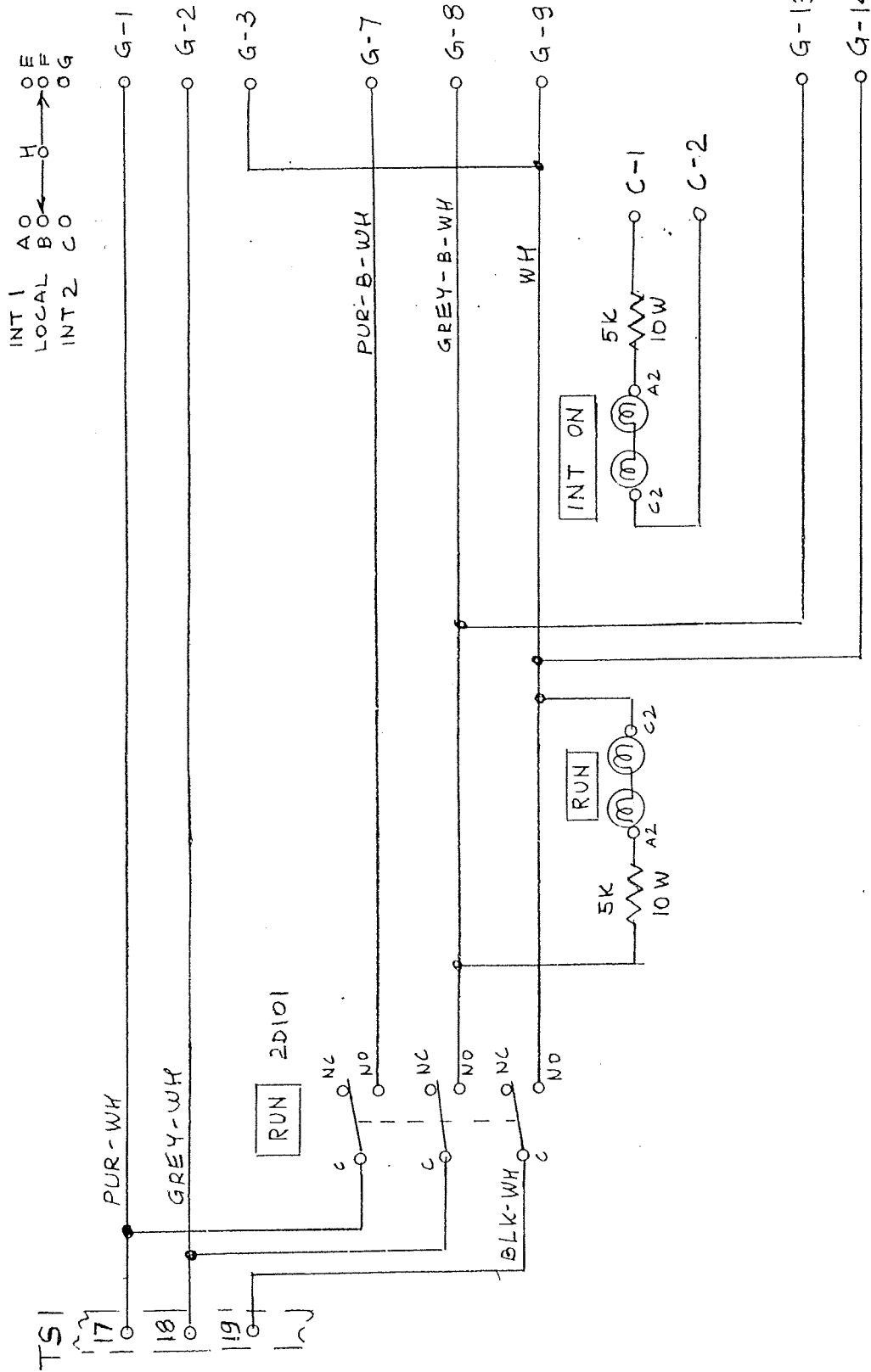

INT 1 AO H OE  
 LOCAL BO ← OF  
 INT 2 CO → OG

<b>MAGNA-TECH ELECTRONIC CO., INC.</b> 630 NINTH AVE., NEW YORK 36, N.Y.	
USED ON	SCALE
PJ - 35 - 3 (INT 2)	~
PJ - 35 - 4	
DRAWN BY ERPOD	
APPROVED BY	
TITLE	
BOOTH CONTROL MODIFICATION	
FWD ONLY, PROJ. AS MASTER	
DATE	DRAWING NUMBER
6-2-68	A-3359