

FILM-TECH

THE INFORMATION CONTAINED IN THIS ADOBE ACROBAT PDF FILE IS PROVIDED AT YOUR OWN RISK AND GOOD JUDGMENT.

THESE MANUALS ARE DESIGNED TO FACILITATE THE EXCHANGE OF INFORMATION RELATED TO CINEMA PROJECTION AND FILM HANDLING, WITH NO WARRANTIES NOR OBLIGATIONS FROM THE AUTHORS, FOR QUALIFIED FIELD SERVICE ENGINEERS.

IF YOU ARE NOT A QUALIFIED TECHNICIAN, PLEASE MAKE NO ADJUSTMENTS TO ANYTHING YOU MAY READ ABOUT IN THESE ADOBE MANUAL DOWNLOADS.

WWW.FILM-TECH.COM

	TITLE AP20 Optical Film Card (H338) Installation and Alignment		NUMBER TN-H457	REV A	PAGE 1 of 14
	DEPARTMENT Engineering	CREATED BY: M. Smith/L. Brown	EFFECTIVE DATE October 28, 2010	APPROVED BY: F. Pflaum	

Introduction

This document describes the installation and alignment of the optional H338 AP20 Optical Film card.

- ☑ This feature is only available with AP20 system software V1.2 and above. Software must be updated, if necessary, **before** installing the H338 card.
- ☑ Please also refer to the AP20 Installation and Operating Guide (*TM-H392 1.2* and above) for more information on the AP20.

The H338 card will enable the playback of standard optical film soundtracks including Mono, A, and SR type. If this card is not yet installed or the optical formats of the AP20 have not been programmed, optical sound playback will not be possible. You must ensure all steps are followed in the installation instructions below.

This card offers two inputs (Projector 1 & 2), see Fig 1 below. Both inputs have an LED to indicate which input is active. The automation in the AP20 must be programmed to switch the inputs at the proper time. In addition to these inputs, there are two Lt/Rt test points. These are BNC type connectors that are used for alignment of the projectors optics.

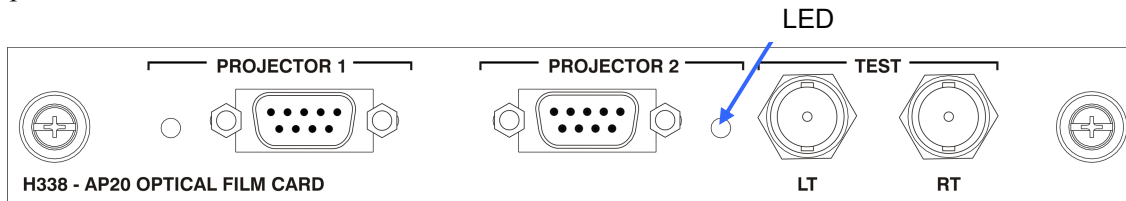
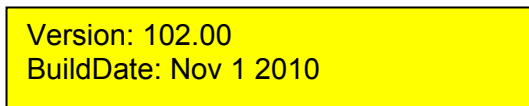

Fig 1 - H338 Optical Film Card

Software Update

⚠ Verify that the AP20 system software is at V1.02.00 or above. If an earlier version of software is installed, it must be updated before installing the H338 card. Failure to update software before installing the H338 card will cause the software to malfunction.

The current AP20 software version may be found by selecting **Menu → System → System Info**. The current version is displayed in the yellow box on the upper left of the screen. The example below shows the earliest acceptable software version.



The latest software version will be included with the H338 card (if provided as part of the H458 field upgrade kit).

Check with Datasat Digital Entertainment Technical support at www.datasatdigital.com for the latest update that will include fixes for known issues and feature enhancements.

Install H338 Card

Tools required: Phillips head #2 screwdriver

⚠ Caution: The H338 card contains parts that are static sensitive. Use caution when handling to avoid damage. Keep the card in the anti-static bag until needed. Just before removing the card from the bag, hold the bag and touch the chassis of the player. This will make your body the same electrical potential as the player (and will prevent static discharge). It is a good idea to stand on a linoleum or cement floor (not carpet) when handling the card.

Date Last Printed: 11/3/2010	P/N 9303H45700A
9631 Topanga Canyon Place, Chatsworth, CA 91311	

	TITLE AP20 Optical Film Card (H338) Installation and Alignment		NUMBER TN-H457	REV A	PAGE 2 of 14
	DEPARTMENT Engineering	CREATED BY: M. Smith/L. Brown	EFFECTIVE DATE October 28, 2010	APPROVED BY: F. Pflaum	

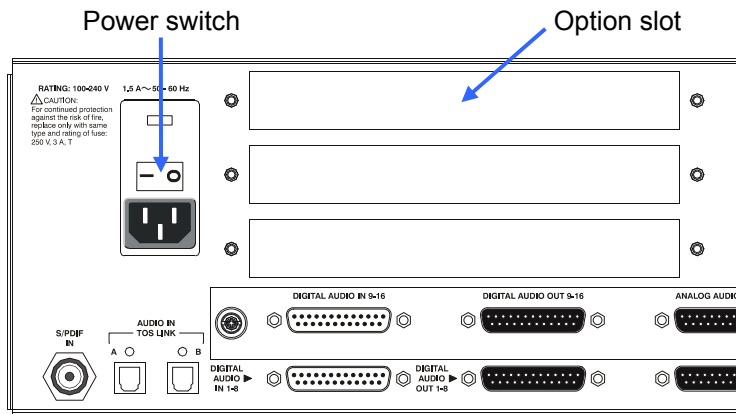

- Turn off the AP20’s rear panel power switch and unplug the power cord.
- Remove one of the three cover plates from the AP20 option slots. All slots are identical.
- Slide the H338 card into the card guides of the option slot and gently push the card into its mating connector. Tighten the attached thumbscrews.

Create Optical Formats

Before the H338 card can be used, Optical formats must be created in the AP20. The H338 card supports standard optical film soundtrack formats: Mono, A-type and SR-type. For the example below, the SR format is created.

Go to Menu → formats → edit formats

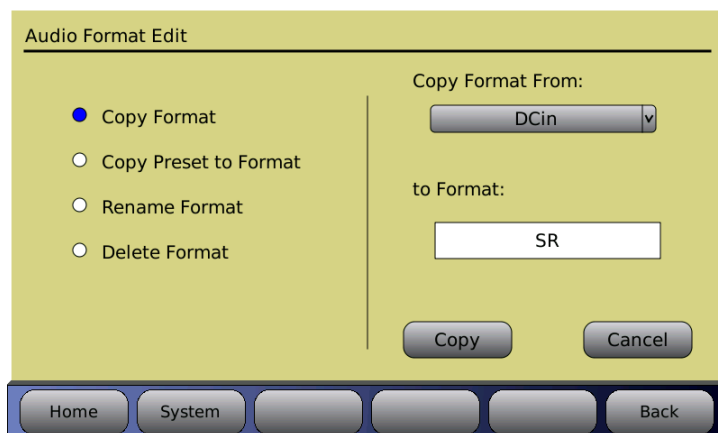



Fig 2: Copy Audio Format

Select a “Copy Format”

Select a format from the drop down menu of “Copy Format From” (in figure 2, above, “DCin” is selected to copy)

Type a new format name into the “to Format” box (in figure 2, above, “SR” has been entered).

Press the “Copy” button

	TITLE AP20 Optical Film Card (H338) Installation and Alignment			NUMBER TN-H457	REV A	PAGE 3 of 14
	DEPARTMENT Engineering	CREATED BY: M. Smith/L. Brown	EFFECTIVE DATE October 28, 2010	APPROVED BY: F. Pflaum		

Select the “Input Source” button. Select “Optical”. A line should appear from the selected source to the output (see figure 3 below). Select the “Back” button

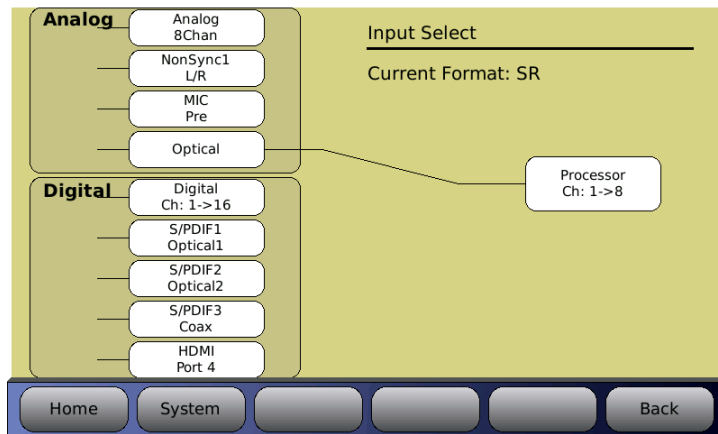

Fig 3: Select Input Source

Select “Assign Buttons”. Use the drop down “Assign” menu to select the desired format, then select a button to assign the format to from the second drop down menu (in figure 4, below, “SR” and “Button 3” have been selected). Press the “Assign” button. The current format assignments are shown below the buttons. The newly selected format should now appear on the list. Select the “Back” button.

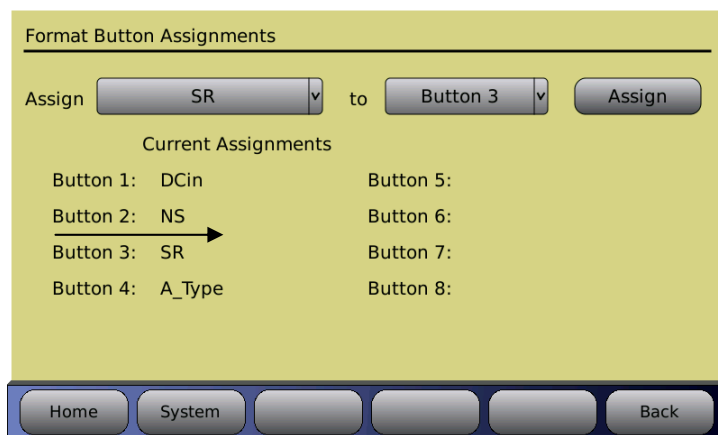



Fig 4: Format Button Assignment

Go to Format Options → Film Options.

- Note:** The **Film Options** button only appears for a format with the **Optical** selected as the input source. If you do not see the **Film Options** button check that you are in the correct format and that the input source is selected for **Optical**.

Select the “Film optical audio type” desired for your format (in figure 5, “SR” has been selected). Select “Matrix Decoder” and/or “Optical Bass Extension” if desired. The selected configuration will be shown in pictorial form in the lower right side of the screen.

	TITLE		NUMBER	REV	PAGE
	AP20 Optical Film Card (H338) Installation and Alignment		TN-H457	A	4 of 14
DEPARTMENT Engineering	CREATED BY: M. Smith/L. Brown	EFFECTIVE DATE October 28, 2010	APPROVED BY: F. Pflaum		

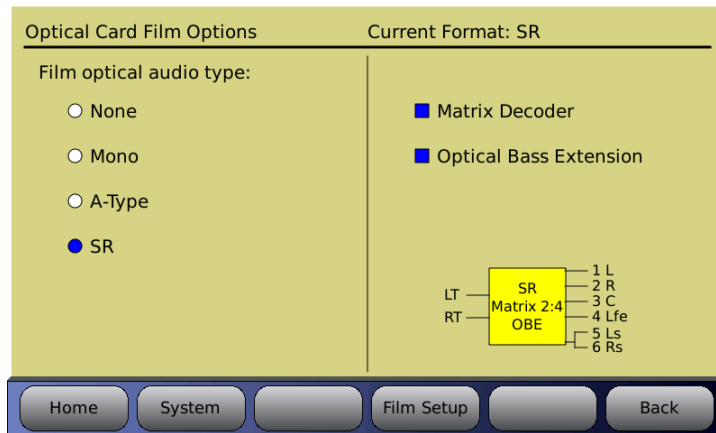

Fig 5: Optical Card Film Options

Alignment

A-Chain alignment consists of calibrating the projector(s) optical film path, the solar cell, and the optical preamp. These adjustments consist of both mechanical alignments on the projector(s) and software settings in the AP20. Adjustments on the projector(s) optical heads differ depending on the manufacturer; however the end results are the same. This section describes briefly the projectors optical head adjustment, for detail adjustments refer to that projector manufacturer's recommended procedure.

Materials and equipment required

For initial mechanical alignment of the projectors optical head, the following is recommended or required. These items are not supplied by Datasat Digital Entertainment.

- RTA – Real Time Analyzer with Microphone
- Oscilloscope
- Voltage meter
- Cotton swabs
- PC (lap top) connected to the internet to connect into the AP20 using VNC (optional)
- Miscellaneous tools needed to make adjustments on projector optics mechanical alignment.

Test Films (not supplied by Datasat Digital Entertainment):

- 50% tone (Cat 69T)
- Pink noise (Cat 69P)
- Buzz Track (P35-BT)
- L/R (Cat 97)
- Illumination uniformity (Cat 566) optional

Inspection and voltage check

Visually inspect the optical film path of the projector. Make sure all components are clean and in good working order. The items that need to be checked are rollers, lateral guides, bearings, dampener, etc. Use a cotton swab, lightly coated with lens cleaner, to wipe the optical lens. Check the LED voltage and adjust it if necessary, as per the manufacturer's recommended procedure.

	TITLE		NUMBER	REV	PAGE
	AP20 Optical Film Card (H338) Installation and Alignment		TN-H457	A	5 of 14
DEPARTMENT Engineering	CREATED BY: M. Smith/L. Brown	EFFECTIVE DATE October 28, 2010	APPROVED BY: F. Pflaum		

Wiring and Connections

Projector 1 & 2 inputs on the AP20 are 9-pin female D-connectors. See Fig 6 below for pin assignments. Input from the solar cell is a 9-pin Male D-connector.

PIN NO.	DESCRIPTION
1	LEFT +
2	LEFT -
3	N.C.
4	RIGHT +
5	RIGHT -
6	LEFT ANALOG GRD.
7	N.C.
8	N.C.
9	RIGHT ANALOG GRD.

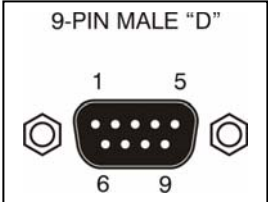

Fig 6: Solar Cell input pin assignment

Prior to optical alignment, verify all wiring and connections are correct. Shielded cables such as Belden 8451 or similar should be used.

The right channel is nearest the edge of the film. To confirm proper wiring, while observing the projector output on a RTA or the AP20 setup screen, place a business card or similar object to block the side of the cell nearest the edge of the film. You should detect a large drop in the right channel level.

Although white light tungsten type exciter lamps have been replaced in projectors with Red LED readers the adjustment and calibrations remain similar. Making adjustments to the film optics will vary depending on the manufacturer; it is recommended that a review of the manufactures recommended alignment adjustments be reviewed prior to making any mechanical changes on the Optical head on the projector.

Mechanical Optical Alignment

Connect the oscilloscope to the AP20 via the Left and Right BNC test connectors on the H338 optical card located on the back of the AP20. See Fig 7.

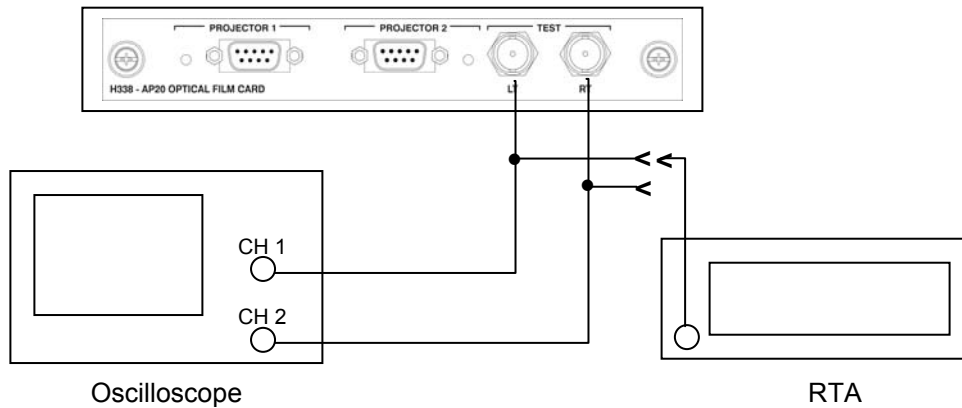



Fig 7 – Test connections

	TITLE			NUMBER	REV	PAGE
	AP20 Optical Film Card (H338) Installation and Alignment			TN-H457	A	6 of 14
DEPARTMENT Engineering	CREATED BY: M. Smith/L. Brown	EFFECTIVE DATE October 28, 2010	APPROVED BY: F. Pflaum			

Step 1: Tone Level Adjustment

Items needed: 50% tone test film (CAT 69T), oscilloscope, and specific tools required to make adjustments, such as Allen/Hex Wrenches, small screw driver etc.

On the AP20 select one of the optical formats in the home screen, next select Menu → Formats → Format Options → Film Options → Film Setup. You should now be in the Film Card Setup screen as shown in Fig 8.

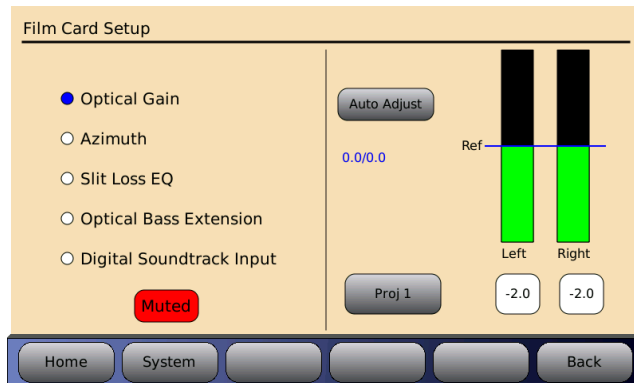

Fig 8 – Film card setup screen

- ☑ Note: When in the Film Card Setup screen, SR decoding is not active and all audio outputs are muted. Changing to another screen will enable SR and un-mute the audio. While in this screen you can also select the red muted button to un-mute the audio.

Thread the 50% tone test film (Cat69T) and run the projector. The signal should now be present on the scope and the AP20 Film Card Setup screen as shown in Fig 8.

Confirm Optical Gain is selected on the left side of the setup screen. Press the Auto Adjust button and within a short time the AP20 will self calibrate to the reference levels. If the auto adjust is unable to self calibrate, a message will appear noting it was unable to complete. If this happens recheck the LED voltage and inspect the visual film path, as noted above, or consult the manufacturer’s manual for your particular sound head. You can also try manually making the level adjustments.

To manually adjust levels, select the projector you need to set by pressing the <Proj> button. Next, select the button below the left input level bar and use the fader knob to increase or decrease this level until it meets the reference line. Repeat this step for the Right channel by selecting the button below that level indicator.

Step 2: Film path check

Items needed: Buzz Track test film, oscilloscope, and specific tools required to make adjustments, such as Allen/Hex Wrenches, small screw driver etc.

Thread up and play the Buzz Track test film. This test film has modulation beyond the scanned optical areas. If the alignment is off, the error can be seen on the oscilloscope and also heard on a monitor. The goal is to align the film path so that the slit image is centered on the soundtrack area of the film. This results in either a null response or equal level on both tracks. While observing the oscilloscope, make adjustments to the projectors optics to achieve one of the examples shown below in Fig 9. Some adjustments are made by moving the projectors film guide laterally, while on others the lens and LED assembly is moved. Refer to the manufacturer’s procedure regarding the proper adjustment for your model projector.

	TITLE		NUMBER	REV	PAGE
	AP20 Optical Film Card (H338) Installation and Alignment		TN-H457	A	7 of 14
DEPARTMENT Engineering	CREATED BY: M. Smith/L. Brown	EFFECTIVE DATE October 28, 2010	APPROVED BY: F. Pflaum		

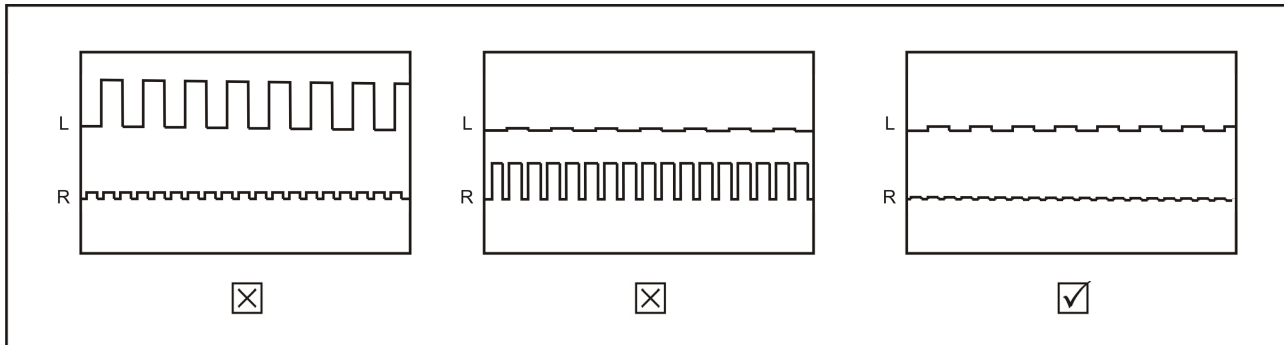

Fig 9: Cell alignment viewed on Oscilloscope using Buzz Track test film

Step 3: Cell Alignment

Items needed: Left/Right test film (CAT 97), oscilloscope and specific tools required to make adjustments, such as Allen/Hex Wrenches, small screw driver etc.

Thread up and play the Left/Right test film (CAT 97). This test checks for crosstalk between the Left and Right channels. The goal is to have both channels at equal level. If necessary, make adjustments to the solar cell by moving it left or right across the film path to achieve results as seen in Fig 10. Refer to the projector manufacturer's procedure for this

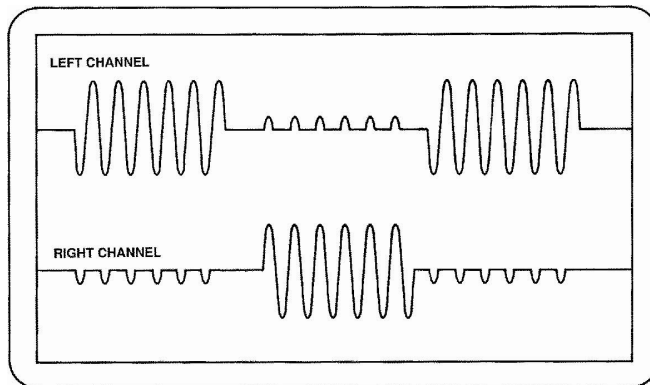



Fig 10: Crosstalk using Cat 97 test film

- Note: while running the CAT 97 test film you can also select Azimuth in the AP20's optical set up screen. If alignment is correct you should be able to observe a cross on the screen as shown in Fig 11. The same applies to viewing on the oscilloscope in X/Y mode.

	TITLE AP20 Optical Film Card (H338) Installation and Alignment		NUMBER TN-H457	REV A	PAGE 8 of 14
	DEPARTMENT Engineering	CREATED BY: M. Smith/L. Brown	EFFECTIVE DATE October 28, 2010	APPROVED BY: F. Pflaum	

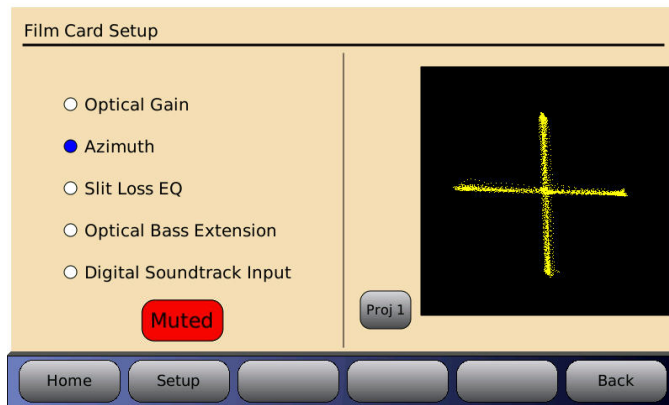

Fig 11: - Optimum LED to lens alignment

Step 4: Azimuth and Focus

Items needed: Pink Noise test film (CAT 69P) oscilloscope, RTA, and specific tools required to make adjustments, such as Allen/Hex Wrenches, small screw driver etc.

Thread Pink noise test film (CAT 69P) and start the projector. Using the oscilloscope in the XY mode, adjust the projector's optics (azimuth and focus controls) for the best diagonal trace, see Fig 12.

This can also be viewed on the AP20 screen by going to Menu → Formats → Format Options → Film Options → Film Setup and Selecting Azimuth.

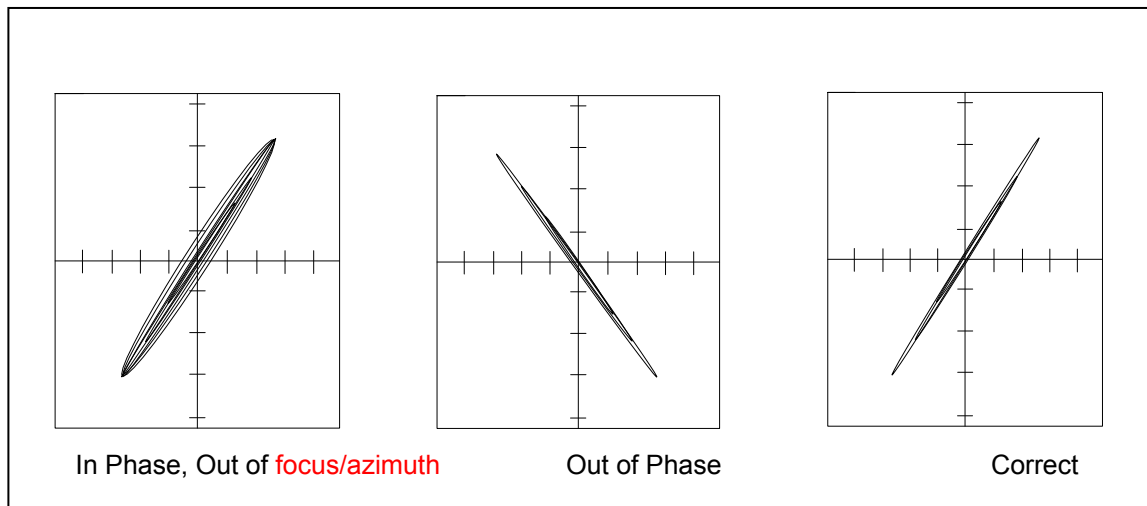



Fig 12 Azimuth

Connect the RTA to one of the test BNC connectors on the H338 preamp card. While observing the response on the RTA, adjust the projector optics for the flattest response. This is achieved by moving the optical lens in or out for the sharpest focus and gently rotate it for straight azimuth, Fig 13.

Once set, move the RTA to the other test point and the results should be the same. Final slit loss correction will be done in the next step. Depending on the design of the projector's optics, both focus and azimuth can interact; refer to the projector's manufacturer for proper adjustment procedure of azimuth and focus.

	TITLE AP20 Optical Film Card (H338) Installation and Alignment		NUMBER TN-H457	REV A	PAGE 9 of 14
	DEPARTMENT Engineering	CREATED BY: M. Smith/L. Brown	EFFECTIVE DATE October 28, 2010	APPROVED BY: F. Pflaum	

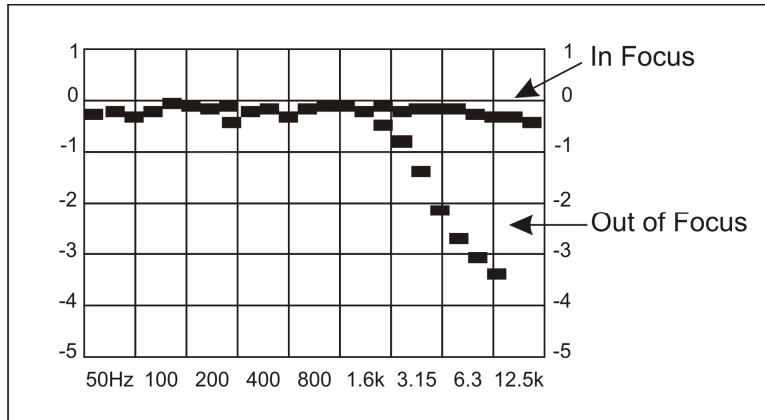

Fig 13 - Focus

After the flattest response is achieved by adjusting the projector optics, the final slit loss correction is made using the Parametric Filter Settings, see Figure 14.

Select Projector 1 or 2 is by pressing the <Proj> button, located below the graph. Left or Right is selected by pressing the button next to the <Proj> button. To adjust Freq, Q, and Gain on the parametric filter settings, simply press the button with the configuration you wish to change. Then use the fader knob to make changes, or the up and down arrows when using a laptop.

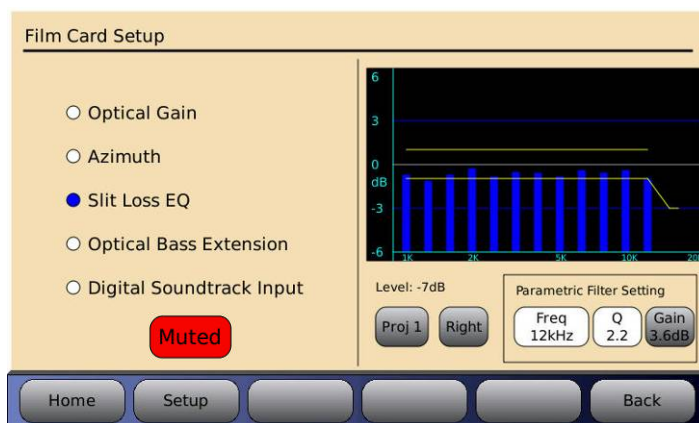



Fig 14 - Slit Loss

	TITLE AP20 Optical Film Card (H338) Installation and Alignment		NUMBER TN-H457	REV A	PAGE 10 of 14
	DEPARTMENT Engineering	CREATED BY: M. Smith/L. Brown	EFFECTIVE DATE October 28, 2010	APPROVED BY: F. Pflaum	

Optical Card Film Options

Select Menu → Formats → Format Options → Film Options. The screen shown in Fig 15 will appear.

- Note: when selecting Menu the last screen viewed will appear, it may be necessary to select the System button to follow path above. Also, you must have an optical format selected on the home screen.

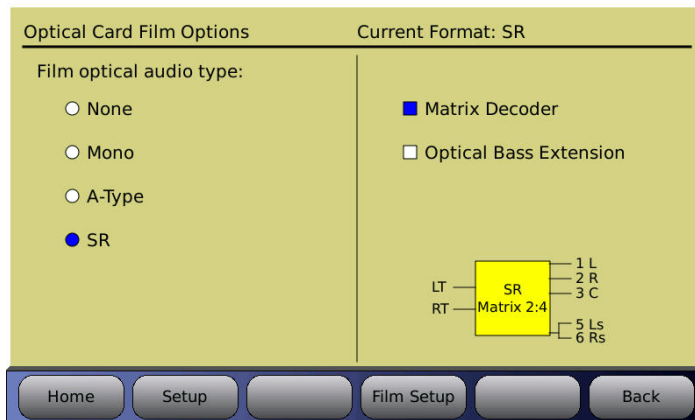

Fig 15 – Optical Card Options

The Current Format will appear in the upper right corner. The format audio type can be assigned by selecting it from the list on the left. The options of Matrix Decoding and Optical Bass Extension are on the right.

Step 5: (OBE) Optical Bass Extension

Items needed: Pink Noise test film (CAT 69P), RTA with Microphone

Go to Menu → Formats → Format Options → Film Options → Film Setup

You should now be in the Film Card Setup screen as shown in Fig 16.

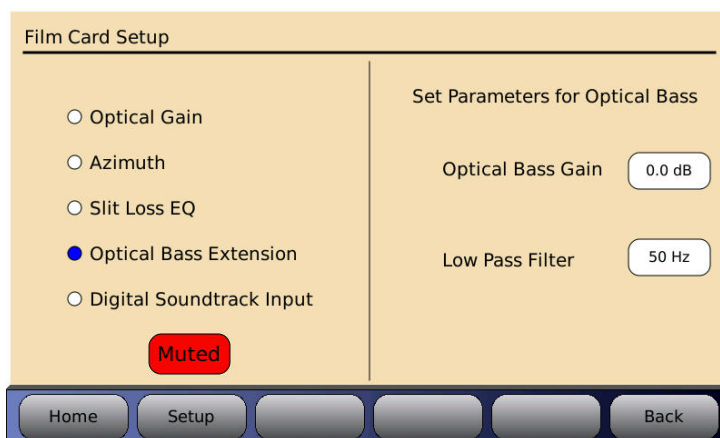



Fig 16 Film Card Setup screen

Once in the Film Card Setup screen, select Optical Bass Extension. Then set up a microphone in the auditorium. It is best to use a single microphone, or if using a multiplexer select single microphone only, and connect it to the RTA.

Thread (Pink noise) Cat 69P test film into the projector. Turn off all amplifiers except the Center channel. Select an optical format on the AP20, start the projector and note the level and low frequency roll off displayed on the RTA.

	TITLE			NUMBER	REV	PAGE
	AP20 Optical Film Card (H338) Installation and Alignment			TN-H457	A	11 of 14
DEPARTMENT Engineering	CREATED BY: M. Smith/L. Brown		EFFECTIVE DATE October 28, 2010	APPROVED BY: F. Pflaum		

Select the appropriate Low Pass Filter setting by pressing that button and using the fader knob to make any changes required to match the low pass filter to the roll off measured.

Next turn on the subwoofer channel, then select the Optical Bass Gain by pressing the <Gain> button. Use the AP20 fader knob, or up and down keys when using a laptop, to adjust the Optical Bass Gain to match the Center channel level previously noted on the RTA display. The Optical Bass Gain range is 0 to +10dBc. Don't forget to turn on all amplifiers when adjustment is complete.

Step 6: Optical Surrounds Delay Settings

To set surround delays, for the optical formats, a “Profile” must be created in the AP20 and assigned to the optical formats. Go to Menu → Formats → Channel Profile → Edit Profiles

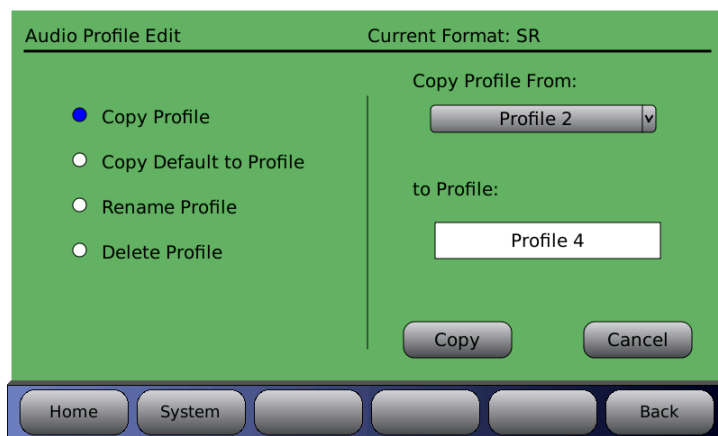

Fig 17. Audio Profile Edit

Select “Copy Profile” and choose a profile to copy from the drop down menu (in figure 17, “Profile 2” has been selected).

Type a profile name into the “to Profile” box (in figure 17, “Profile 4” has been entered). Press “Copy”.

Select “Channel Delays”. Enter the desired delay (in milliseconds) into the left and right surround channels. The delay is entered by selecting the delay box under the desired channel and then dialing in the correct value using the front panel rotary encoder. In figure 18, below, the left and right surround delays have been set to 40mS.

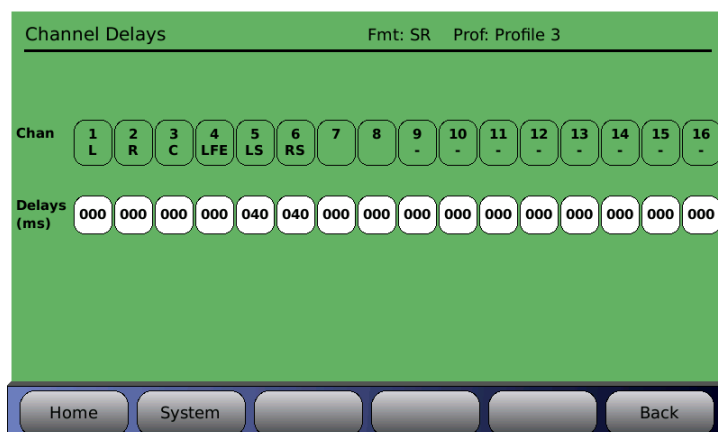



Fig 18. Channel Delays

	TITLE		NUMBER	REV	PAGE
	AP20 Optical Film Card (H338) Installation and Alignment		TN-H457	A	12 of 14
DEPARTMENT Engineering	CREATED BY: M. Smith/L. Brown	EFFECTIVE DATE October 28, 2010	APPROVED BY: F. Pflaum		

Step 7: Digital Soundtrack Input

This allows for a smooth cross fade from the optical playback to an analog or digital input source. If one of these inputs is being used, make the selection here. See Fig 19.

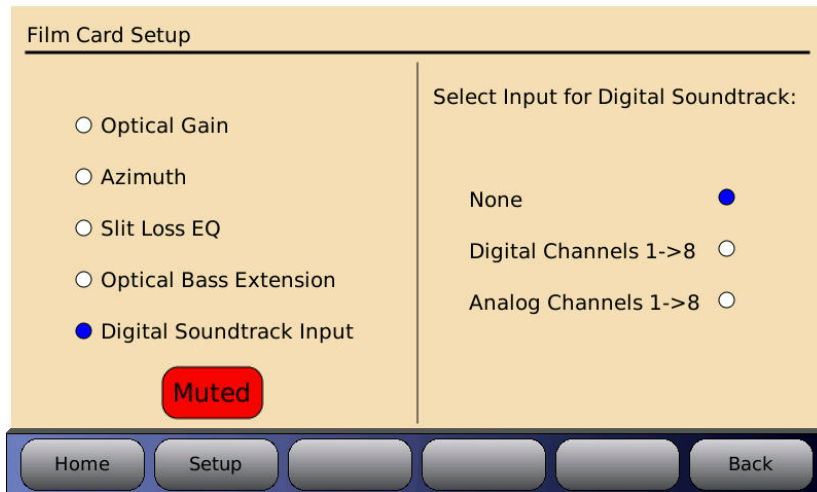
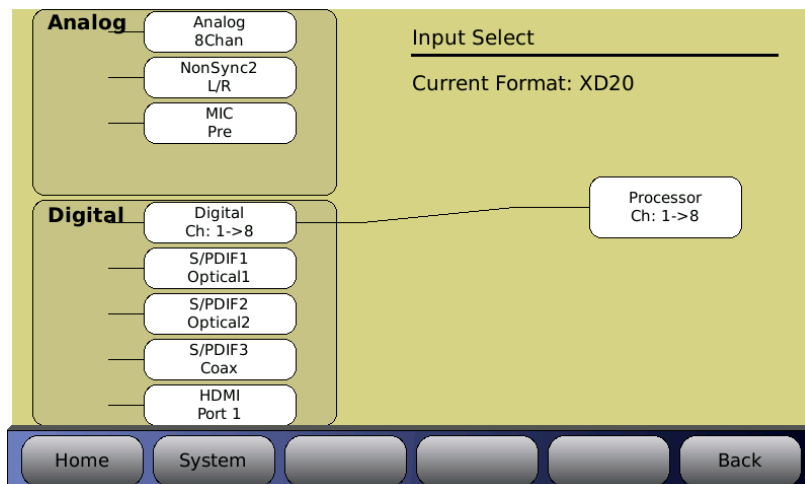

Fig 19 – Digital Soundtrack Input selection

- ☑ Note: When the Digital Channels input is used for the digital soundtrack you must make sure that the input selection is **Digital Ch: 1->8** as shown in the Input Select screen below. The other options, **Digital Ch: 1->16** or **Digital Ch: 9->16** should not be used because it eliminates the crossfade function between digital and optical. Pressing the **Digital Ch:** button repeatedly allows you to change the digital channel selection.



	TITLE		NUMBER	REV	PAGE
	AP20 Optical Film Card (H338) Installation and Alignment		TN-H457	A	13 of 14
DEPARTMENT Engineering	CREATED BY: M. Smith/L. Brown	EFFECTIVE DATE October 28, 2010	APPROVED BY: F. Pflaum		

Step 8: Recheck tone levels

See Step 1 above: Tone Level Adjustment. If any adjustments were made it may be necessary to set these levels again, follow the procedure in Step 1, this will complete the optical alignment.

Trouble shooting

No activity seen on AP20 Film Card Setup Screen.

Confirm projector optical LED is on, next check connections from Projector to H338 card, confirm which Projector input is being used, and check that LED light is on next to input, if not select an optical format on the home screen.

The AP20 mutes when switching from optical card to digital or analog input source

Go to the Film Card Setup screen and select Digital Soundtrack Input, in this menu choose the input source in use, analog or digital.

	TITLE		NUMBER	REV	PAGE
	AP20 Optical Film Card (H338) Installation and Alignment		TN-H457	A	14 of 14
DEPARTMENT Engineering	CREATED BY: M. Smith/L. Brown	EFFECTIVE DATE October 28, 2010	APPROVED BY: F. Pflaum		

Copyright Protection

Copyright 2010, Datasat Digital Entertainment. All rights reserved. Patent pending.

The content of this publication is subject to change without notice. Datasat Digital Entertainment assumes no obligation to notify you of any changes or updates. While Datasat Digital Entertainment believes this publication is accurate, due to ongoing improvements and revisions, Datasat Digital Entertainment cannot guarantee the accuracy of printed material, nor can it accept responsibility for errors or omissions. Datasat Digital Entertainment may periodically publish updates and revisions to this publication as it deems necessary.

Datasat Digital Entertainment Technical Support

Datasat Digital Entertainment Headquarters	DTS Digital Cinema Ltd
Email: techsupport@datasatdigital.com	Email: eusupport@datasatdigital.com
Tel outside USA: +1.818.401.4253	Tel: +44 (0) 118.934.9199
Tel in USA: 888.428.2268	Fax: +44 (0) 118.934.9198
Fax: +1.866.448.6802	www.datasatdigital.com
www.datasatdigital.com	