

# FILM-TECH

**THE INFORMATION CONTAINED IN THIS ADOBE ACROBAT PDF FILE IS PROVIDED AT YOUR OWN RISK AND GOOD JUDGMENT.**

**THESE MANUALS ARE DESIGNED TO FACILITATE THE EXCHANGE OF INFORMATION RELATED TO CINEMA PROJECTION AND FILM HANDLING, WITH NO WARRANTIES NOR OBLIGATIONS FROM THE AUTHORS, FOR QUALIFIED FIELD SERVICE ENGINEERS.**

**IF YOU ARE NOT A QUALIFIED TECHNICIAN, PLEASE MAKE NO ADJUSTMENTS TO ANYTHING YOU MAY READ ABOUT IN THESE ADOBE MANUAL DOWNLOADS.**

**[WWW.FILM-TECH.COM](http://WWW.FILM-TECH.COM)**

Filmosound  
**644Q**

**INSTRUCTION  
BOOKLET**

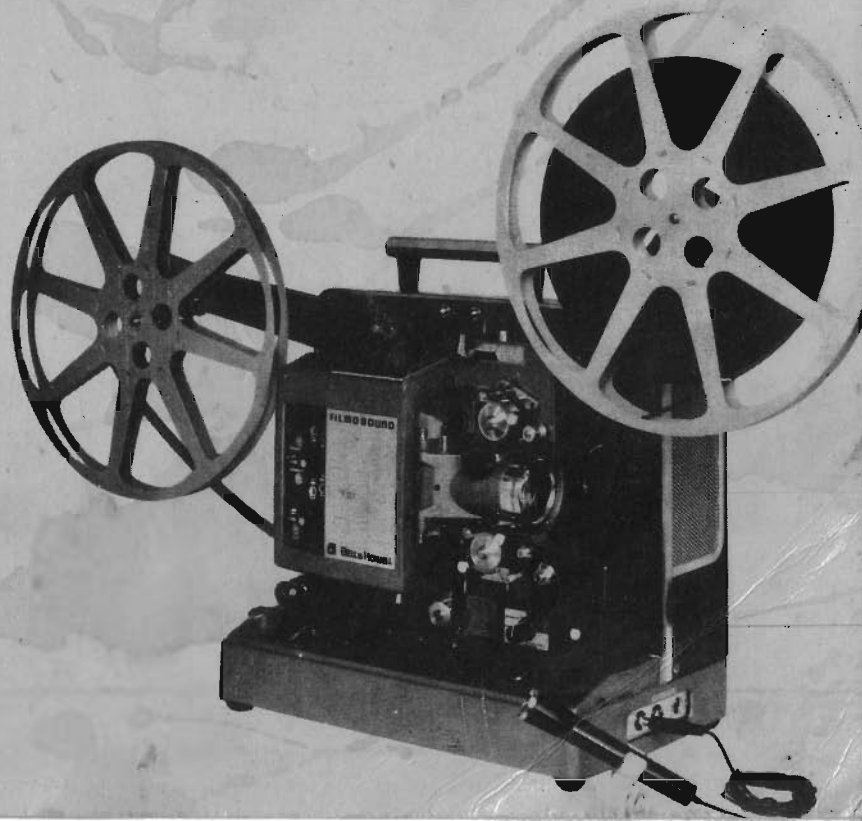

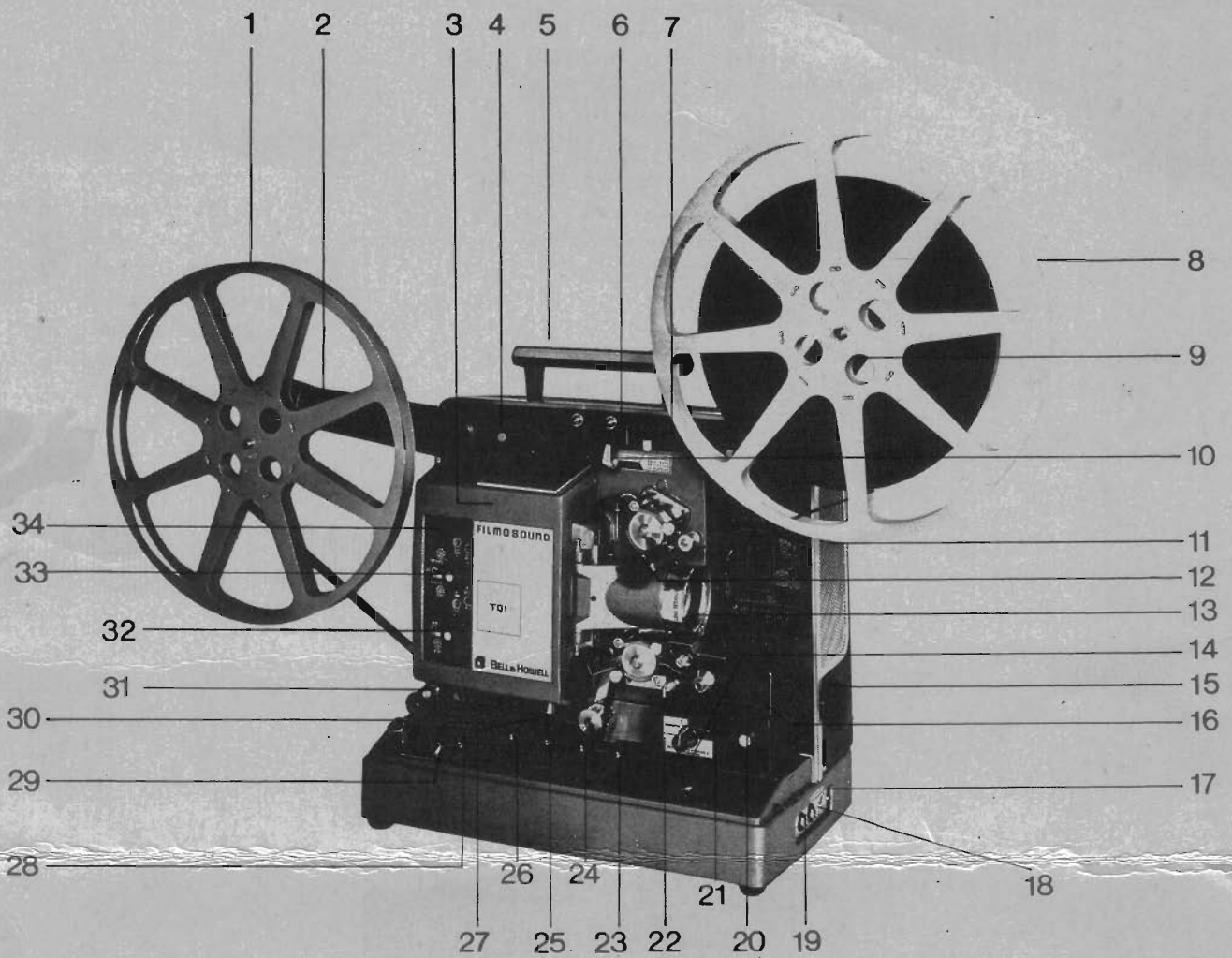

- |    |                    |    |                          |    |                           |
|----|--------------------|----|--------------------------|----|---------------------------|
| 1  | Take-up spool      | 11 | Loudspeaker              | 25 | Treble tone control       |
| 2  | Rear spool arm     | 12 | Focusing knob            | 26 | Bass tone control         |
| 3  | Lamphouse cover    | 13 | Projection lens          | 27 | Lamphouse knob            |
| 4  | Arm release button | 14 | Animation button         | 28 | Monitor socket            |
| 5  | Carrying handle    | 15 | Tilt control             | 29 | Recording level indicator |
| 6  | Framing control    | 16 | Exciter lamp door        | 30 | Record button             |
| 7  | Rewind button      | 17 | Accessory speaker outlet | 31 | Guide roller              |
| 8  | Front spool        | 18 | Gramophone input socket  | 32 | Still picture control     |
| 9  | Front spool arm    | 19 | Microphone input socket  | 33 | Direction switch          |
| 10 | Speed selector     | 20 | Securing screw           | 34 | Control panel             |
|    |                    | 21 | Exciter lamp cover       |    |                           |
|    |                    | 22 | Mag/opt selector switch  |    |                           |
|    |                    | 23 | Opt/phon volume control  |    |                           |
|    |                    | 24 | Mag/mic volume control   |    |                           |

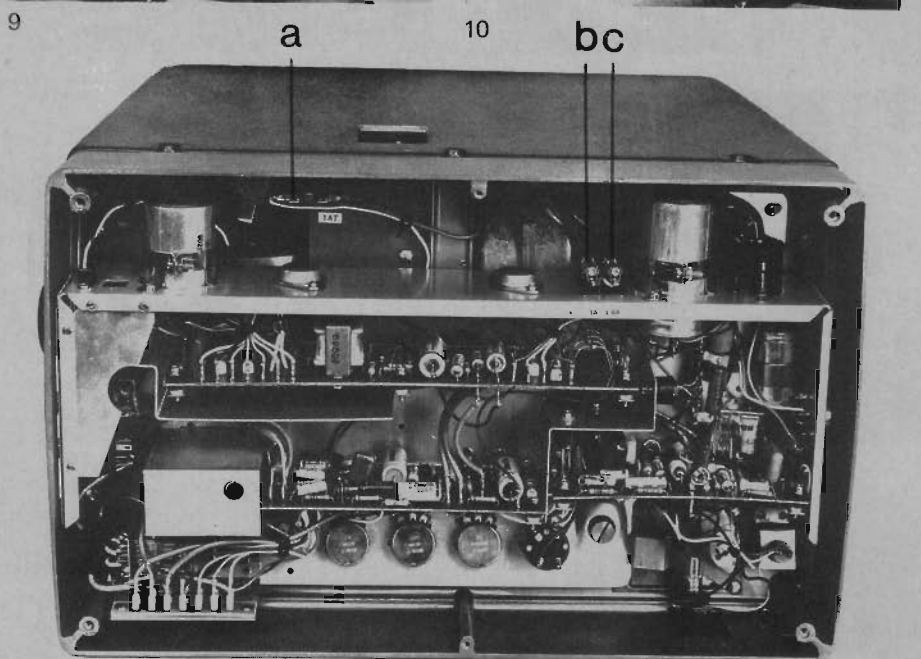
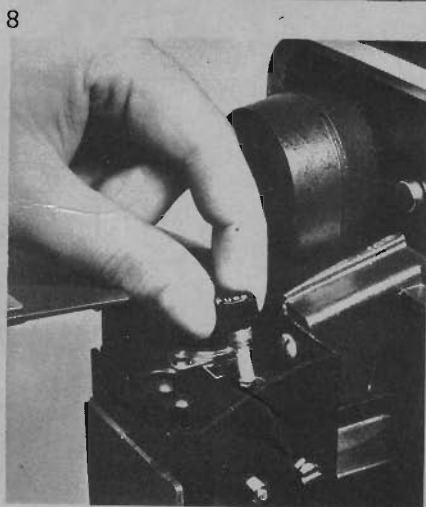
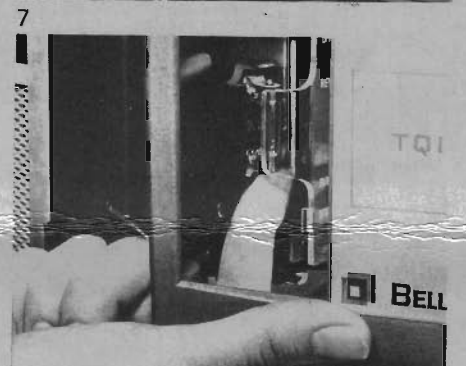
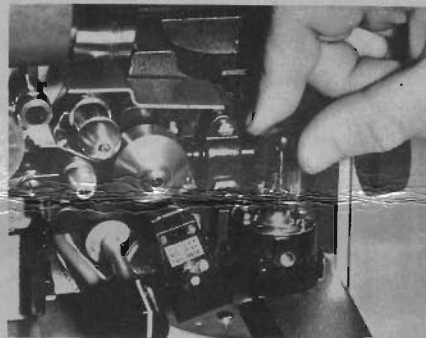
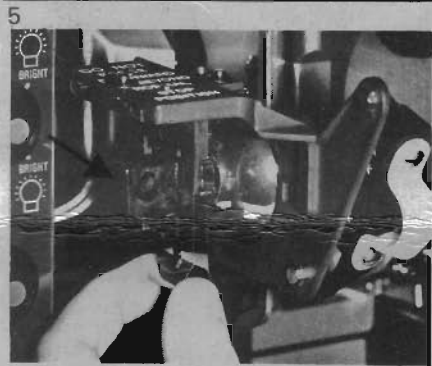
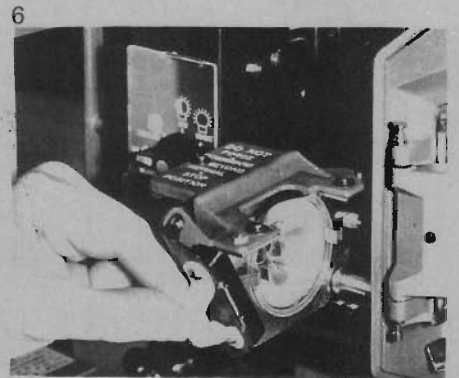
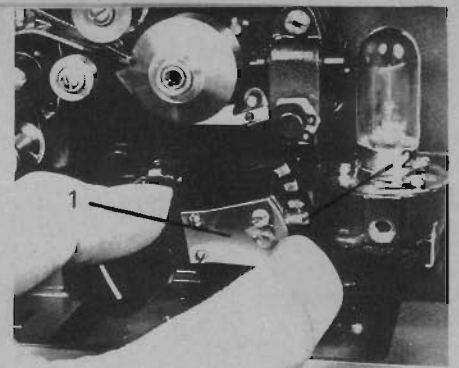
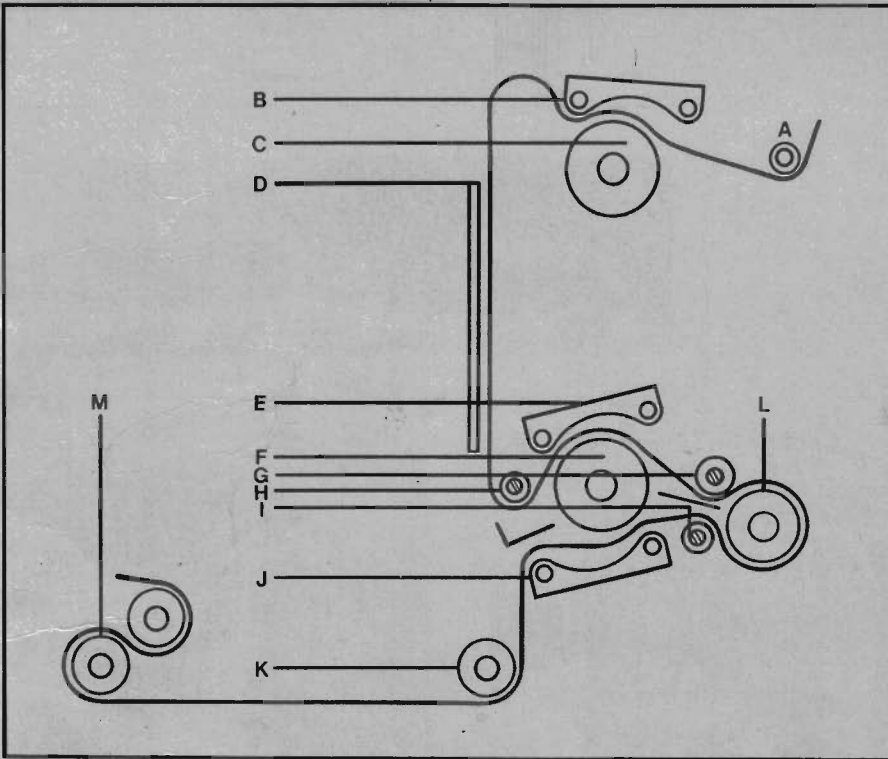

11

Projected picture widths

Lens focal length

	25 mm	32 mm	40 mm	50 mm	64 mm	80 mm	100 mm
*ft.	ft. in.	ft. in.	ft. in.	ft. in.	ft. in.	ft. in.	ft. in.
8	3 0	2 6	1 11	1 6	1 3	1 0	9
10	3 10	3 2	2 4	1 11	1 7	1 2	11
12	4 6	3 10	2 10	2 3	1 11	1 5	1 2
15	5 9	4 9	3 6	2 10	2 5	1 9	1 5
20	7 8	6 4	4 9	3 10	3 2	2 5	1 11
25	9 6	7 11	5 11	4 9	3 11	3 0	2 4
30	11 5	9 6	7 2	5 9	4 9	3 7	2 11
35	13 4	11 1	8 4	6 8	5 6	4 2	3 4
40	15 2	12 8	9 6	7 8	6 4	4 9	3 10
45		14 3	10 8	8 6	7 1	5 4	4 3
50		15 10	11 11	9 6	7 11	6 0	4 9
60			14 3	11 5	9 6	7 2	5 9
75				14 3	11 11	8 11	7 2
100					15 10	11 11	9 6
125						14 10	11 11

\*Distance from projector to screen

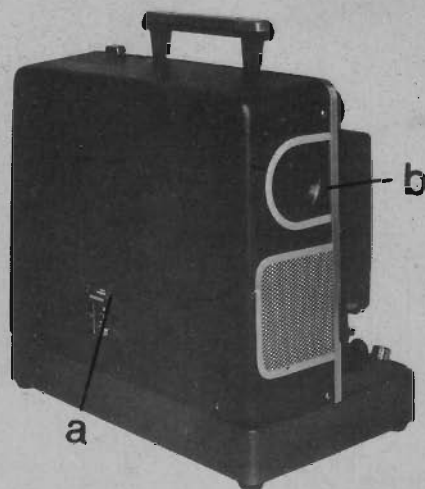
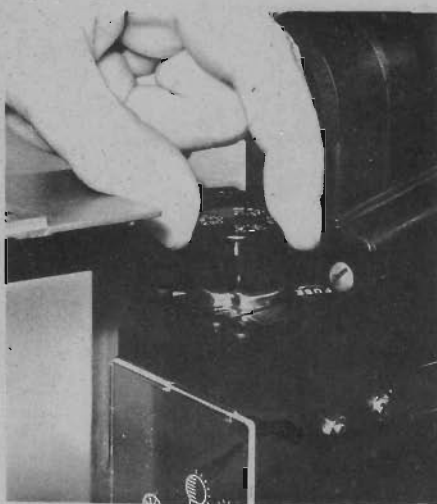

2

3

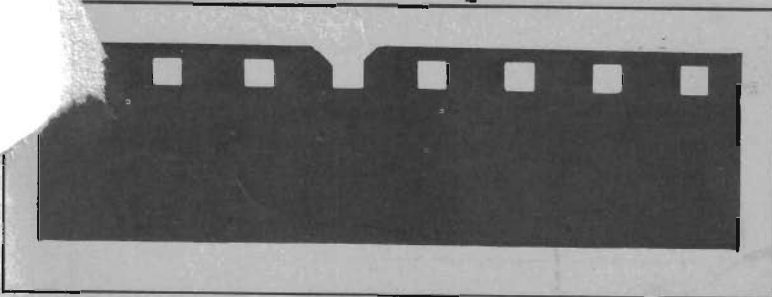

4

## INDEX

---

### TECHNICAL INFORMATION

#### NORMAL OPERATION

- 1-4 Preparation
- 5-9 Electrical connections
- 10-19 Preliminary test
  - Pre-threading checks
- 20-29 Threading procedure
  - Loss of loop
- 30-44 Sound film projection
- 45-46 Silent film projection
- 47 Still picture projection
- 48 Animation
- 49 Reverse projection
- 50-54 Rewinding
- 55 Closing the projector

#### SOUND TRACK RECORDING

- 56-66 Commentary recording
- 67-71 Commentary and music recording
- 72-73 Changing magnetic head

### SPECIAL APPLICATIONS

- 74-75 Public address and record player
- 76 Accessory loudspeaker
- 77 Auditorium loudspeaker

### CARE AND MAINTENANCE

- 78 Storage
- 79 Periodic inspection
- 80 Lubrication
- 81-88 Cleaning
- 89-92 Lamp replacement
- 93-94 Fuse replacement

### GUARANTEE

### FAULT FINDING

### PROJECTED PICTURE SIZES

---

## TECHNICAL INFORMATION

---

Power supply	200-250V. 50Hz. a.c. only
Input wattage	450W.
Projection lamp	Tungsten-halogen, Type A1/235, 24V., 250W.
Exciter lamp	Pre-aligned Type G/29. 4V., 0.75A.
Control panel lamp	Festoon. 24V., 5W.
Fuse, main	2.5A., time-lag, 5mm x 20mm
Fuses, auxiliary	1AT. (internal relays, control panel lamp) 1A. (exciter lamp) 1.6A. (amplifier)
Amplifier output	25W.
Output load impedance	8 and 16 Ohms
Weight	45.5lb./21kg.
Dimensions	Length: 15 $\frac{1}{2}$ in./40.3cm Width: 9 $\frac{1}{4}$ in./24.7cm Height: 15 $\frac{1}{2}$ in./39.4cm
Spool capacity	2,000ft./600m

---

# normal operation

---

## PREPARATION

Inside the front and back covers of this booklet are illustrations showing your Filmosound 644Q projector. The operating instructions will be easier to follow if you unfold these illustrations before reading any further. Numbers in brackets in the text below refer to the corresponding numbers on the illustration at the front.

- 1 Place the projector on a stand or other firm support with the tilt control (15) facing the screen.
- 2 Slide the cover latch button to the rear (see Fig. 1). Pull the top of the cover slightly towards you with the other hand and lift it away from the projector.
- 3 Raise the front spool arm (9) until a click is heard.
- 4 Raise the rear spool arm (2) until, just above the horizontal, a click is heard.

## ELECTRICAL CONNECTIONS

Your Filmosound projector is designed to operate on 50Hz alternating current supplies within a range of 200 to 250V. It can be used outside these limits only in conjunction with an external transformer.

- 5 Pull the lamphouse knob (27) and swing open the hinged lamphouse cover.
- 6 Set the voltage selector (see Fig. 2) to match the supply voltage by lifting the selector, rotating it until the arrow is pointing to the correct voltage range, and then pressing the selector firmly down again.
- 7 Close the lamphouse door. A click indicates that the lock has engaged.

- 8** Fit the moulded rubber plug of the mains lead into the socket (see Fig. 3a) at the other side of the projector. It will fit only one way.
- 9** If no mains plug has been fitted, attach a suitable plug to the three bare ends of the lead. These connections should be made with:-

GREEN/YELLOW to Earth  
 BROWN to Live  
 BLUE to Neutral

If a fused plug is used, the fuse should have a value of 5A.

## PRELIMINARY TEST

- 10** Set the direction switch (33) on the main control panel (34) to OFF and the still picture control (32) to RUN. Turn all the knobs on the sloping control panel fully anticlockwise. Set the mag/opt selector switch (22) to Position 3.
- 11** Connect the mains lead plug to the supply. The control panel lamp will light, indicating that the connections made are correct. (If the lamp does not light, see page 16.)
- 12** Turn the bass control knob (26) clockwise to switch on the exciter lamp. The lamp may be inspected by opening the exciter lamp door (16). (If it does not light, see page 16.)
- 13** Listen to the loudspeaker (11). A faint "hissing" noise will confirm that the sound system is functioning. (If no sound is heard, see page 16.)
- 14** Turn the direction switch (33) to FORWARD and the projector mechanism will start.
- 15** Turn the direction switch (33) one step further to "DIM". The projection lamp will now light. (If it does not, see page 16.)
- 16** With the projector running, set the speed selector (10) to the correct Silent or Sound setting for the type of film you intend to show. Do not attempt to alter the setting of the speed selector unless the projector is running.

- 17** Adjust the focusing knob (12) until the illuminated picture aperture on the screen has a sharp outline.
- 18** Turn the tilt control (15) and move the projector sideways until the illuminated "picture" is centred on the screen.

NOTE: The picture should just fill the screen without leaving an unlit white area around the outside of the screen. To achieve this, it may be necessary to alter the distance between projector and screen or change the projection lens (13). A table on the back cover of this booklet gives the relationship between picture size and projector lens at varying distances from projector to screen.

- 19** Return the direction switch (33) to OFF. The projector is now ready for the film to be threaded.

## PRE-THREADING CHECKS

Is the spool holding the film distorted? If so, straighten gently by hand. A badly warped spool may damage the film or fail to revolve properly on the projector.

Is the film correctly wound? With all sound (single-perforated) film, the perforations should be nearest the operator when the spool is mounted as in the illustration at the front of this booklet. With magnetic striped film, ensure in addition that the brown stripes beside the picture are facing away from the screen as the film leaves the front spool. Silent (double-perforated) film is correctly threaded when the picture in the gate is both upside-down and mirror-reversed (to check this, try to find a title or some other wording on the film); the less shiny, "emulsioned" side of the film should be nearer the screen.

If up to three consecutive perforations are torn, cut a notch with scissors, as shown in Fig. 4. If four or more are torn, the projector should be threaded only after the film has been unwound beyond the point of damage.

Remove from the film any adhesive tape, staples, grease-pencil marks, or anything else likely to do damage or introduce dirt into the film path.



## THREADING PROCEDURE

- 20 Firmly grasp the front of the projection lens (13) and swing it away from the projector until the lens mount is released from its catch and open fully.
- 21 Open all three sprocket guards (B, E and J in Fig. 5) until they lock in the open position. This requires upward pressure at the front of B and E, downward pressure at the rear of J.
- 22 Pull off about 4ft./1.5m of film from the front spool (8).
- 23 Following the path shown on the projector body immediately below the front spool arm (and also in Fig. 5), guide the film under the front roller (A) and then between the upper sprocket guard (B) and the sprocket wheel (C) until the teeth engage with the perforations. Close the sprocket guard by pressing it downwards at the front until a click is heard.
- 24 Leaving enough slack in the film so that it forms a curve corresponding to the line printed on the projector to the rear of the top sprocket wheel, seat the film centrally against the aperture plate (D).
- 25 Holding the film flat against the aperture plate with the left hand, loop it under roller (H) and ease it between the underside of the sprocket guard (E) and the top of the sprocket wheel (F). Lead the film forward and under the spring-loaded roller (G), which can be lifted upward while this is being done, to the top of the sound drum (L). Push the film into the space between the sound drum and the exciter lamp cover (21) as far as the three o'clock position, leaving the remainder free.
- 26 After ensuring that the perforations have engaged with the teeth at the top of the lower sprocket wheel, if necessary adjusting the position of the film until they do, close the lens mount firmly until it engages with its spring catch. Close sprocket guard (E) by pressing it downwards at the front until it clicks.
- 27 Continue threading the film around the sound drum (L), over the roller (I) and, without engaging the sprocket holes, between the

lower sprocket guard (J) and the sprocket wheel (F). Still without engaging the sprocket holes, lead the film downwards under roller (K) and horizontally towards the rear to the underside of the back roller (M).

- 28 Pull the film gently but steadily to the rear at (M) until the stabilising rollers (G and I) have opened to their extreme position and push the film inwards between the lower sprocket guard (J) and the sprocket wheel (F) until the perforations are in line with, but not entered by, the sprocket teeth. Release the tension at (M), allowing the film to be pulled backwards by the spring-loaded stabilising rollers (G and I) until, with a slight click, the perforations engage with the teeth on the sprocket wheel. Close the lower sprocket guard (J) by pushing it upwards at the rear.
- 29 Rotate the inching knob (see Fig. 3b) at the rear of the projector for a few turns in an anti-clockwise direction. If the threading procedure has been properly carried out, the loops of film above and below the gate will not change in size as the film passes through the projector and the two spring-loaded stabilising rollers (G and I) will move up and down together. (The two rollers should remain constantly about  $\frac{1}{8}$ in./6mm apart. If the gap is smaller, poor quality sound will result.) Loop the film over the roller (M) and round the guide roller (31) and attach it to the hub of the take-up spool (1). Rotate the spool clockwise to take up the slack.

## LOSS OF LOOP

Damaged perforations or poor splices may result in the tightening of the lower loop of film, below the projector gate. On Filmosound projectors, this loop is automatically and instantaneously restored by the small roller below the gate (H in Fig. 5). There is no need for any action on the part of the projectionist — unless the film is in such poor condition that the roller is constantly in action, in which case it may be wisest to rethread the projector beyond the worst damage.

## SOUND FILM PROJECTION – OPTICAL

- 30 Thread the film as described in Stages 20-29. Check that the speed selector (1) is set to the SOUND position. Remember that speed must be changed only when the projector is running. Check that the still picture control (32) is set to RUN.
- 31 Set all sound controls (on sloping control panel) fully anticlockwise.
- 32 Turn the base control (26) clockwise to switch on the exciter lamp and set to Position 5. The treble control (25) should also be set to Position 5.
- 33 Turn the direction switch (33) to FORWARD.
- 34 As soon as the first picture frame after the leader enters the gate, turn the direction switch to the "BRIGHT" (full light) position. For projection in small rooms, the "DIM" (reduced power) setting will probably be sufficient and the lamp will last longer.
- 35 Make final adjustments with the focusing knob (12) and tilt control (15).
- 36 If a frame line appears above or below the picture, turn the framing control (6) until the line disappears.
- 37 Make final sound adjustments with the opt/phon volume (23) treble (25) and bass controls (26).
- 38 At the end of the film, turn the direction switch (33) to FORWARD (switching off the lamp) and set the opt/phon volume control to zero. As soon as the film has run clear of the projector, turn the direction switch to OFF.

## SOUND FILM PROJECTION – MAGNETIC

Your model 644Q will reproduce sound tracks recorded magnetically on striped film in addition to optically recorded sound tracks. Such films are recognised by their having a band of brown oxide at the side

of the film, opposite the sprocket holes or, in the case of double-perforated film, on the outer edge of the film. (Both types of film have a second band on the edge opposite to the active magnetic sound track. This is solely to make the film stack evenly on the spool and does not carry a recording.)

Reproduction of magnetic sound is done by a magnetic head plug located below the sound drum (L in Fig. 5) and behind the exciter lamp cover (21). Although removeable (see Stage 72), this plug can be left in position when projecting optically recorded films.

NOTE: Films with magnetic sound tracks should always be threaded with the projector's selector switch (22) at Position 3. The switch should be moved to Position 2 (full- and half-width tracks) or Position 1 (quarter-width tracks) only when threading has been completed.

## REPRODUCING FULL-WIDTH MAGNETIC TRACKS

Full-width magnetic sound tracks are found only on single-perforated sound film.

- 39 Ensure that the full-track magnetic head plug, supplied with your Filmosound 644Q projector, is in position and that the mag/opt selector switch (22) is set to Position 3. Turn the opt/phon volume control (23) and mag/mic volume control (24) to Position 0.
- 40 Thread the film as in Stages 20-29.
- 41 Move mag/opt selector switch to Position 2.
- 42 Project film as in Stages 30-38 but with the opt/phon volume control at 0 and the mag/mic volume control set to give a satisfactory level of sound.

## REPRODUCING HALF-WIDTH MAGNETIC TRACKS

Half-width magnetic sound tracks are encountered mostly on films where it has been found necessary to provide an alternative commentary to the original, optical recording but without the optical recording being obliterated. A half-width magnetic track may be found on an education-

al or training film that requires commentaries at two levels of understanding, or on a film made for showing mainly in one country but also in others.

If desired, it is possible to reproduce sound from both the magnetic and optical sound tracks at once by simultaneously adjusting the two volume controls on the projector.

- 43** To project a film with a half-width magnetic track, proceed as in Stages 39-42. As half-width recordings require greater amplification than full-width tracks, it is necessary to set the mag/mic volume control (24) to a higher number than for a full-width recording.

NOTE: If projection (or recording) of half-stripe films takes place more than very occasionally, it is advisable to substitute the correct half-track magnetic head plug for the projector's own standard full-track head, which would otherwise suffer uneven wear and in time become useless for reproducing full-width sound tracks. See "Changing Magnetic Head Plug," page 11. Half-track magnetic head plugs of two types, for tracks on the inner and outer halves of the sound track area, are available as accessories (outer half, Bell & Howell part no. 9041548; inner, part no. 9041549). For details, ask your Bell & Howell dealer.

## REPRODUCING QUARTER-WIDTH (EDGE-STRIPE) TRACKS

Sound from quarter-width tracks, found almost only on double-perforated filmstock of the kind used for silent films, can be replayed only with the quarter-track magnetic head plug, which is available as an accessory (Bell & Howell part no. 9027043).

- 44** Proceed as in Stages 39-42, ensuring first that the quarter-track magnetic head plug is in position and moving the mag/opt selector switch (22) to Position 1 immediately after threading the film.

## SILENT FILM PROJECTION

- 45** Set the direction switch (33) momentarily to FORWARD and, while the projector is running, turn the speed selector (10) to SILENT. The speed selector should not be moved when the projector is at STOP.
- 46** Turn all sound controls fully anticlockwise. Then proceed as in Stages 20-29 and 33-36 above.

## STILL PICTURE PROJECTION

- 47** The film can be stopped at any time to project a still picture by moving the still picture control (32) to STOP. This automatically places a safety screen between the lamp and the film to protect it from heat damage; because of this, the brightness of the picture is inevitably reduced. It is necessary to refocus a still picture and to refocus again when normal operation is resumed.

## ANIMATION

- 48** The stationary picture obtained in Stage 47 can be changed by pressing the animation button (14). Brief pressure on this button will advance the film one frame at a time, allowing a detailed analysis of movement. This can be done in FORWARD and REVERSE directions.

## REVERSE PROJECTION

- 49** The movement of the film through the projector can be reversed. Turn the direction switch (33) to REVERSE, pausing briefly at OFF until the mechanism stops to prevent strain. To project reverse movement on the screen, move the switch past REVERSE to either of the bottom two lamp positions. (There is no need to turn the volume down during reverse running, as the sound is automatically switched off.)

## REWINDING

- 50** While supporting the rear spool arm (2) with your left hand, press the arm release button (4) and move the arm upwards. Remove pressure from the button and continue to raise the arm until it clicks in the vertical position.
- 51** Lead the free end of the film from the take-up spool (1) to the underside of the front spool (8) and engage it in the slot or other fixing device on the spool hub. Rotate the front spool two or three turns anticlockwise to ensure that the film does not become detached from it.
- 52** Turn the direction switch (33) to reverse and then press the rewind button (7), holding it down for a few seconds while an internal clutch engages and fast rewind begins. The button should be held down long enough for the tension exerted by the rear (full) spool to lock on the rewind clutch (4-5 seconds with a lightly loaded spool).
- 53** As soon as all film has been wound off the rear spool, switch to OFF. Remove the full spool from the front arm by inserting the fingers in two of the holes in the spool and pulling it off the spindle, at the same time pressing on the tip of the spindle with your thumb.
- 54** Press the rear arm release button (4) to unlock the rear spool arm and lower it to the normal (horizontal) operating position.

## CLOSING THE PROJECTOR

- 55** After the performance, remove both spools and, using the spool arm release buttons (4 and its feed spool equivalent), fold both arms downwards and inwards as far as they will go. Turn the tilt control (15) fully anticlockwise. Remove all leads from their sockets.
- Lift the cover and, holding it slightly away from the projector at the top, lower it on to the pedestal in such a way that the small

lugs at the front and rear of the pedestal enter the slots on the inside of the cover. Then close the gap at the top until, with a click, the cover latch engages.

---

# sound recording

---

Your Filmosound Model 644Q projector is capable of recording high-quality sound on any film bearing a satisfactory full-track, half-track or quarter-track magnetic stripe.

Speech, music and sound effects can all be recorded and, with a little care, "mixed" to provide a well-balanced sound track which you can replay immediately as often as you wish, or which a motion-picture laboratory can convert easily into a permanent optically recorded track. Sound recorded on a magnetic stripe can be erased and re-recorded at any time you want to make a change.

All that you need in order to record a commentary with your Model 644Q projector are a suitable microphone (one is supplied with the projector) and a magnetic "stripe" which any company offering a magnetic-stripping service will add to your film at a very moderate cost. Your Bell & Howell dealer will be glad to advise on this. Music and sound effects can be transferred from tape or disc, using suitable equipment of your own choosing.

The instructions below tell you how to record a simple commentary-only or speech-and-music sound track on your film. A little time spent on making yourself thoroughly familiar with the recording procedure and on rehearsing your commentary will greatly enhance your results.

**NOTE:** Your 644Q projector is supplied with a full-track magnetic head plug for recording and replaying sound tracks on full-width magnetic stripe. The same head will perform equally well with half-stripped

film (but see the note following Stage 43). Quarter-width stripe is normally applied only to film with perforations along both edges. To record and replay quarter-width tracks, a special quarter-track magnetic head is available as an accessory.

## COMMENTARY RECORDING

- 56** Ensure that the correct magnetic head plug is fitted for the kind of magnetic stripe on your film. (How to change a magnetic head is explained in Stages 72-73.) The recording procedure is otherwise similar for all widths of track.
- 57** Set the mag/opt selector switch (22) to Position 3 (optical sound) and thread the film as described in Stages 20-29, making sure that the magnetic stripe is facing away from the screen as the film leaves the front spool.
- 58** Move the selector switch to Position 2 for full-width or half-width stripe, to Position 1 for quarter-width stripe.
- 59** Set the still control (32) at STOP, switch on the amplifier (bass control knob), and turn the opt/phon volume control (23) to zero.
- 60** Connect the microphone (supplied with the projector) to the microphone input socket (19), and turn the direction switch (33) to FORWARD to start the projector motor.
- 61** Press the record button (30). The recording level indicator (29) will immediately start to glow, showing that the recording circuits are ready for operation.
- 62** To set a satisfactory recording level, speak into the microphone no louder than you intend to read your commentary and, at the same time, adjust the mag/mic volume control (24) until the swinging needle of the recording level indicator (29) reaches the shaded portion of the scale but at no time remains over it.
- 63** When you are ready to begin recording, restore the still picture control (32) to RUN, the direction switch (33) to one of the two

lamp positions, and read your commentary, keeping the microphone at the same distance from the mouth and speaking at the same level of loudness as in making the test described in Stage 62. If your commentary is to begin near the start of the first scene, it may be found helpful to project the final few seconds of leader to provide a starting cue.

NOTE: By using the headset supplied with the projector, it is possible to hear the actual sounds being recorded as recording takes place. The headset should be plugged into the socket labeled MONITOR (28), beside the recording level indicator.

- 64** If during recording you make a mistake, there is no need to go back to the beginning. Simply stop the projector, run the film back to a convenient pause in the commentary, and record afresh from then on. In fact, it may be found easier to run the film backwards to a point before the pause, restart forward projection and press the record button (30) only when the pause is reached. The record button must always be pressed when re-recording takes place as moving the direction switch to REVERSE automatically switches the recording circuits off. This is a safety interlock to prevent accidental erasure of an existing recording.
- 65** When the recording is complete, set the mag/mic volume control (24) to zero before switching off the projector.
- 66** To check the recording, rewind the film as in Stages 50-54, re-thread the projector in the normal way with the selector switch (22) at Position 3, and project the film with the selector switch reset to the position used for recording. This time, however, do not press the record button or your commentary will be erased.
- NOTE: The monitor headset supplied with your 644Q projector is not intended for listening to playback but an appropriate headset can be used instead of the loudspeaker for this purpose if fitted with a plug suitable for insertion in the loudspeaker socket (17).

## RECORDING COMMENTARY WITH MUSIC

Background music, carefully chosen and appropriately used, adds polish to most kinds of film. It is easy to record a "mixed" sound track with music and commentary by linking your Filmosound 644Q projector to a suitable gramophone or tape recorder.

Whichever you use (tape recorder or gramophone) to provide the music for your film, it must have a connecting jack plug of the right size to fit the projector's gramophone input socket (18) and, if it is a gramophone, a pick-up with an output of at least 300mV. Where the pick-up is fitted with a crystal or ceramic cartridge, the gramophone may be connected directly to the projector input. Moving-iron and moving-coil pick-ups have a smaller output and should be used only in conjunction with an equalising pre-amplifier. (Record-players with built-in loudspeakers and no provision for direct connection to the projector are not suitable for good quality recording.)

If you are in any doubt about the suitability of your sound-reproducing equipment, consult your dealer.

- 67 Set up the projector and thread the film as described in Stages 56-59.
- 68 Connect the microphone to the microphone input socket (19) and the gramophone or tape recorder to the gramophone input socket (18).
- 69 Press the record button (30), thus preparing the recording circuits for operation and bringing the recording level indicator (29) into action.
- 70 Using the headset to monitor the sound from microphone and tape or disc reproducer, set appropriate recording levels as described in Stage 62. Use the mag/mic volume control (24) to adjust recording level for commentary; use the opt/phon volume control (22) for the music. To help you achieve a well-balanced recording, with neither music too loud nor commentary too quiet, the gramophone input socket on the Model 644Q has been made less sensitive than the microphone input.

- 71 Record your sound track as described in Stages 63-65, using the monitor headset to listen to the recording as it is made and making appropriate sound-level adjustments by means of the two volume controls. (Best results will be obtained when an assistant is available, either to read the commentary or to manipulate the projector controls.)

NOTE: The microphone supplied with your Model 644Q projector is a moving-coil type with impedance of 50,000 Ohms at 1kHz. If required, any other microphone of medium impedance (i.e. from 10,000 to 60,000 Ohms) may be used instead, provided it is sensitive within the range -60 to -40dB.

## CHANGING MAGNETIC HEAD PLUG

Before removing or inserting a magnetic head plug, make sure that the magnetic/optical selector switch (22) is fully clockwise at position 3 (optical sound).

- 72 To remove a magnetic head plug, undo the securing screw (20) and take off the exciter lamp cover (21). Press the plug by means of the plate (numbered 1 in Fig. 6) as far as it will go and rotate the plug fully anticlockwise. Withdraw the plug from the projector locating pin.
- 73 To insert a magnetic head plug, hold the plug with the stud (2 in Fig. 6) horizontal and pointing to the right and engage the hole at the rear of the plug with the projector locating pin. Push the plug fully in, then rotate it clockwise as far as it will go. Remove pressure from the plug and pull it gently towards you to ensure that it locates in the correct working position.

# special applications

## PUBLIC ADDRESS SYSTEM

### 74 *Microphone*

To make announcements, or to speak a commentary for silent films, connect the microphone by inserting the jack plug into the microphone input (19). Adjust volume by means of the mag/mic volume control (24). If the system "howls" — caused by sound from the loudspeaker entering the microphone and being re-amplified — hold the microphone in such a position that it is shielded from the loudspeaker. If this is not sufficient, the volume setting should be reduced until stability is achieved.

NOTE: The two independent volume controls on the Model 644Q allow comments spoken into the microphone to be superimposed on the sound from the film. This facility can be useful for making urgent announcements or for adding supplementary explanations.

### 75 *Record Player*

A record player with a crystal or high-impedance dynamic pick-up may be used to provide music before and after the performance or during a silent film. It should be connected into the gramophone input socket (18) and the volume adjusted as for a microphone. If there is a separate volume control on the record player, it is worth experimenting with different settings of this and the projector's opt/phon volume control (23) to determine which combination gives the most satisfactory results.

## ACCESSORY LOUDSPEAKER

76 The 6in./15cm elliptical loudspeaker built into the Filmsound 644Q projector provides good-quality sound reproduction for

rooms and small halls but cannot take full advantage of the substantial power and frequency range of the amplifier. For optimum sound reproduction, an accessory speaker (obtainable from your Bell & Howell dealer) should be used. This is provided with a 50ft./17m lead terminating in a plug which is inserted in an accessory speaker output socket (17) of the projector amplifier. Insertion of this plug automatically disconnects the internal loudspeaker.

For the best sound quality, the accessory speaker should be located above or high up on one side of the screen and aimed towards the centre of the audience. It should not be below the level of the heads of the audience, nor behind the screen.

The lead to the accessory speaker should be positioned, on its run from the projector to the screen, so that it is not likely to become entangled with the feet of the audience. Keeping it above ground level eliminates this risk and also prevents the lead from becoming dirty.

## AUDITORIUM LOUDSPEAKER

77 The Filmsound projector can also be connected to an existing auditorium loudspeaker system if the total impedance of the speaker(s) is from 8 to 16 ohms. Such a connection requires a special plug (obtainable from your Bell & Howell dealer) to fit the accessory speaker output socket (17) on the projector.

NOTE: The 25W. amplifier of your Model 644Q projector delivers more power than a single accessory loudspeaker can handle. If the volume control is advanced beyond the point where distortion is heard, damage to the loudspeaker may result.

---

# care & maintenance

---

## STORAGE

- 78 Store the projector away from moisture and excessive heat and, whenever possible, keep it in a carton or other enclosure to prevent the entry of dust. A protective cover (obtainable from your Bell & Howell dealer) is available as an accessory and will keep your Filmosound projector clean and free from scratches.

## PERIODIC INSPECTION

- 79 It is recommended that periodic inspections be carried out by a Bell & Howell service agent. This will ensure that the equipment remains in first-class condition.

## LUBRICATION

- 80 Do not oil or lubricate in any way. Your Filmosound projector has a permanent factory-sealed lubrication system.

## CLEANING

### (a) Projection Lens

- The coated surfaces of a high-quality lens are easily damaged and it is best not to touch them until inspection of the exposed front and rear elements of the lens shows that cleaning is required.
- 81 To remove the lens, turn the focusing knob (12) anticlockwise until the lens stops moving; then, grasping the lens firmly, pull it out.
- 82 With a camel-hair brush, carefully remove dust from the front and rear surfaces. Polish the surfaces lightly with a fresh lens

tissue (obtainable from your dealer or any optician) or a clean, soft and lintless cloth; avoid excessive pressure on the glass, as scratching will impair definition. If marks are still present after polishing, a lens cleaning fluid may be used.

- 83 To replace the lens, insert it in its mount and, pressing it to the rear, rotate the focusing knob (12) clockwise to engage.
- 84 Avoid touching the glass with the fingers. Should this happen, however, remove any fingerprints; they will spoil definition and may, if allowed to remain, leave a permanent trace on the surface coating.

IMPORTANT. The high efficiency of the dichroic reflector around the projection lamp depends upon a surface coating which is extremely delicate. In no circumstances should this be touched with bare hands or cleaned by any of the usual lens-cleaning methods. After long periods of running, dust may be visible on the front surface. It can safely be removed by light strokes with a clean camel-hair or sable brush of the type made for cleaning lenses but no other method of cleaning should be used.

### (b) Pressure Shoe and Aperture Plate

- 85 Film is delicate and easily scratched if dirt, introduced by a previous film, is allowed to remain in the region of the picture gate. Always, before threading a film, open the lens mount and, with a gate brush or clean cloth, remove all foreign matter from the pressure shoe attached to the lens mount and from the aperture plate which guides the film past the projection aperture.
- 86 Occasionally, films will cause a deposit to accumulate in the pressure shoe/aperture area, especially on the runners. Inspect this area at intervals, or whenever the projector begins to run noisily, and remove any deposit with a piece of hard wood or plastic. NEVER USE METAL OBJECTS FOR THIS PURPOSE.

### (c) Magnetic Head

- 87 Particles from the magnetic coating on the film may in time



accumulate on the magnetic head on the underside of the "rocking" section of the plug, where they may affect reproduction. The head should therefore be cleaned with a soft brush to remove loose dirt. Dirt still adhering to the polished surface of the head after brushing can usually be eased off with a piece of sharpened wood or plastic but may, in obstinate cases, first need to be softened with one of the solvents made for cleaning the magnetic heads of tape recorders. NEVER USE A METAL OBJECT WHEN CLEANING THE MAGNETIC HEAD AND, BECAUSE OF ITS EXTREME PRECISION AND DELICACY, ALWAYS HANDLE THE HEAD WITH GREAT CARE.

(d) *Other Areas*

- 88 All other parts of the projector which the film touches should be kept clean. Follow the path of the film from spool to spool and from time to time remove all dust and dirt from rollers and stationary surfaces with which it makes contact. Remove the exciter cover (21) and wipe the curved surface that fits round the drum.

## LAMP CHANGE

### *Projection Lamp – Removal*

Take great care when changing a lamp not to touch the front surface of the special dichroic reflector, which could be irreparably damaged as a result. For instructions on cleaning this reflector, see the paragraph under Stage 84 above.

- 89 Switch off the projector and disconnect mains supply. Pull the lamphouse knob (27) and swing open the hinged lamphouse cover.

Pull the white handle above the lamp towards you and downward through 90°, allowing the lamp assembly to rest in a horizontal position against its stop (see Fig. 7).

Gently pull off the insulated connecting block (arrowed in Fig. 8)

from the pins at the rear of the lamp. Do this by grasping the block itself.

With the thumb and finger, pull down the plated retaining clip until it reaches its stop (see Fig. 8).

Holding the pins of the lamp with the left hand, pull the defective lamp to the rear and discard.

### *Projection Lamp – Replacement*

- 90 With the left hand, hold the new lamp by its contact pins in such a way that the notch in its circular plate is in the six-o'clock position. (Tungsten-halogen lamps may fail prematurely if their quartz bulbs are touched with bare fingers and they should therefore be handled only by their metal parts. If the bulb is inadvertently touched, wipe it gently but thoroughly with a soft, clean cloth, or a fresh paper tissue).

Insert lamp through the hole in the holder from the rear, ensuring that the notch in its circular plate corresponds to the "key" on the holder and that the plate is fully seated in its recess.

Keeping gentle forward pressure on the two pins, raise the retaining clip as far as it will go.

The lamp is now secure. Replace the connecting block, pushing it fully home. Then, using the white handle, raise the swing-down lamp assembly to its working position and push it inward gently but firmly until a click indicates that its spring catch has engaged.

Close lamphouse cover.

Reconnect power supply and continue projection.

### *Exciter Lamp*

- 91 If the sound fails during projection of a film with optical sound track, but electrical noise can still be heard in the loudspeaker when the volume is turned up, it may be that the exciter lamp has failed. To check, open the exciter lamp door (16).

To replace the exciter lamp, loosen the securing screw (20) and remove the exciter lamp cover (21). Push the lamp lock lever to

the right (see Fig. 9) to release the lamp, then rotate the lamp a few degrees anticlockwise until it can be lifted clear of the guide pins.

Locate the new lamp over the guide pins (it will fit in only one position), press it down and rotate it clockwise until the narrow ends of the slots reach the pins. Swing the lamp lock lever to the left, replace the exciter lamp cover and tighten the securing screw.

### Control Panel Lamp

- 92 Place the rear spool arm (2) in the rewind position and open the lamphouse cover (3) by pulling gently on the lamphouse knob (27). The lamp is mounted behind the curved extension of the control panel, held between two spring contacts which press inwards upon its metal ends (see Fig. 10). To remove the lamp, ease it out from between the contacts. To fit the replacement, locate it on one of the contacts and then, applying slight pressure, ease the other end into position at the other contact until it is secure. Close the lamphouse cover. The best working position when replacing this lamp is from the rear of the projector, through the aperture in the lamphouse cover. It may be found helpful to turn the projector on its side.

## FUSE REPLACEMENT

### Main Fuse

- 93 One 2.5A. cartridge fuse of the special time-lag type is located next to the voltage selector at the top of the lamphouse (see Fig. 11).

To remove, disconnect the equipment from the mains supply by pulling the power plug from the projector, open the lamphouse cover, unscrew the fuseholder and lift it out of its recess. Pull out the faulty fuse, replace it with a spare and, pressing lightly downward, screw the holder back into place. Close the lamphouse cover and reconnect the power lead.

### Auxiliary Fuses

- 94 To gain access to the auxiliary fuses, disconnect the projector from the mains by removing the power plug and lay the projector on its side. Unscrew the four rubber feet, the two screws in the centre of the bottom cover and the spreader bar of the tilt control. The bottom cover can now be lifted away.

The low-voltage supplies to the internal relays and the control panel lamp are protected by a 1A. tubular fuse, labelled "1AT". This fuse is removed by easing it from its clip (see Fig. 12a).

There is a separate fuse for the supply to the exciter lamp. Replace, by easing from its clips, the 1A. fuse marked "1A". (see Fig. 12b).

There is a third fuse, 1.6A., for the supply to the amplifier. Replace fuse marked "1.6A." (see Fig. 12c).

## GUARANTEE

This new Bell & Howell product is guaranteed to be free from imperfection in both material and workmanship for one year from date of original purchase. Should any part of this equipment be defective, it will be replaced or repaired free of charge (except for transportation), providing the equipment has been operated according to the instructions accompanying it. No liability is assumed for film which is damaged or is unsatisfactory for any reason and no liability is assumed for interruptions in operation of equipment.

This guarantee is void:

- A If equipment has been damaged by accident or mishandling.
- B If equipment has been serviced by other than the Bell & Howell approved service stations.
- C If adaptations or accessories other than Bell & Howell have been made or attached.

## FAULT FINDING

SYMPTOM	CAUSE/REMEDY
1 CONTROL PANEL LAMP DOES NOT LIGHT	Turn direction switch to FORWARD (a) If motor runs, lamp is faulty and should be changed (see Stage 92) (b) If motor does not run:- i Check mains supply and plug. ii Check seating of rubber plug in projector socket. iii Check main fuse in lamphouse (see Stage 93). iv Check auxiliary fuse "1AT" (see Stage 94).
2 NO SOUND	(a) Amplifier not switched on (see Stage 12). (b) Amplifier fuse blown. Change fuse "1.6A." (see Stage 94). (c) Exciter lamp burned out. Change lamp (see Stage 91). (d) Exciter lamp fuse blown. Change fuse "1A." (see Stage 94). (e) Obstruction of sound optical system by dirt. Clean. (f) Magnetic head not properly located (see Stage 73). (g) Defective transistors, photo diode or magnetic head.
3 PROJECTION LAMP DOES NOT LIGHT	Lamp burned out. Replace (see Stage 89).
4 INADEQUATE VOLUME	(a) Volume control insufficiently advanced or wrong control used. (b) Poor sound track on film (check with known film). (c) Obstruction of sound optical system by dirt. (d) Defective transistors or photo diode. (e) Defective, dirty or misaligned exciter lamp. (f) Incorrect magnetic head plug. Change (see Stages 39-44).

5	POOR QUALITY SOUND	<ul style="list-style-type: none"> <li>(a) Speed selector set in "silent" position. If so, change setting only with projector running.</li> <li>(b) Causes listed under "Inadequate Volume".</li> <li>(c) Film is slack around the sound drum. Rethread film (see Stages 20-29)</li> <li>(D) Unsuitable setting of tone controls.</li> <li>(e) Magnetic head plug not properly located (see Stage 73) or incorrect head fitted (see Stages 39-44).</li> </ul>
6	RUN/STOP NOT WORKING	Failure of fuse "1AT" (see Stage 94).
7	PICTURE DULL ON SCREEN	<ul style="list-style-type: none"> <li>(a) Low mains voltage.</li> <li>(b) Extraneous light on screen.</li> <li>(c) Dirty lamp or projection lens.</li> <li>(d) Dense film.</li> </ul>
8	PICTURE UNSTEADY ON SCREEN	Lost loop. Rethread film (see Stages 20-29).
9	SCRATCHES APPEARING ON FILM	Dirt in gate or elsewhere along film path (see Stage 85).
10	PROJECTOR NOT RECORDING	<ul style="list-style-type: none"> <li>(a) Selector Switch set in wrong position (see Stage 58).</li> <li>(b) Magnetic head plug not properly located (see Stage 73) or incorrect head fitted (see Stages 39-44).</li> <li>(c) Amplifier not switched on (see Stage 12).</li> <li>(d) Amplifier fuse blown. Change fuse "1.6A." (see Stage 94).</li> <li>(e) Microphone not properly connected (see Stage 60).</li> <li>(f) Record button not pressed (see Stage 61).</li> <li>(g) Mag/mic volume control set too low. Check recording level (see Stage 62).</li> </ul>