

FILM-TECH

THE INFORMATION CONTAINED IN THIS ADOBE ACROBAT PDF FILE IS PROVIDED AT YOUR OWN RISK AND GOOD JUDGMENT.

THESE MANUALS ARE DESIGNED TO FACILITATE THE EXCHANGE OF INFORMATION RELATED TO CINEMA PROJECTION AND FILM HANDLING, WITH NO WARRANTIES NOR OBLIGATIONS FROM THE AUTHORS, FOR QUALIFIED FIELD SERVICE ENGINEERS.

IF YOU ARE NOT A QUALIFIED TECHNICIAN, PLEASE MAKE NO ADJUSTMENTS TO ANYTHING YOU MAY READ ABOUT IN THESE ADOBE MANUAL DOWNLOADS.

WWW.FILM-TECH.COM

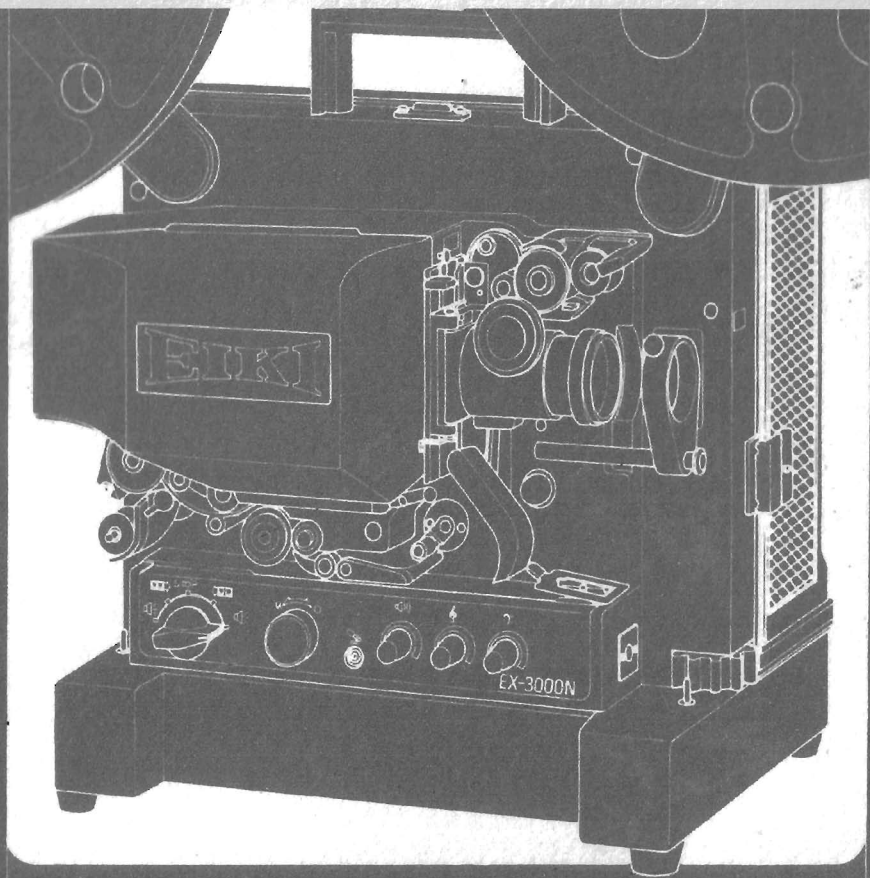

OWNER'S INSTRUCTION MANUAL

16mm Sound Projector

XENON

EX-3000-N



When the show must go on.

EX-3000-N XENON PROJECTOR

This Operator's Manual is easy to read, informative and helpful. Please read it carefully. Before you try it your way, please try it our way.

CONTENTS

	Page
Specifications	1
Main Parts of the Projector	2 ~ 4
Setting Up	5 ~ 8
Installing the Lamp	9 ~ 10
Adjusting the Lamp Focus	11 ~ 12
Threading Instructions	13
Projecting	14
Rewinding	15
Removing the Lens	16
Recommended Spare Parts and Accessories	17 ~ 18
Special Applications	19 ~ 22
(a) Using projector as a P.A. System	19
(b) Magnetic sound track playback-3000N2 only	19
(c) 50Hz to 60Hz conversions	20
(d) Universal voltage selection	21
(e) Silent film operation	22
Cleaning and Maintenance	23
Operator Trouble Shooting Guide	24 ~ 25

SPECIFICATIONS

Power source	Universal voltage: 100, 110, 120, 220, 240V. 50/60Hz
Power consumption	0.87kw
Lamp	New short-base 350w ozonefree Xenon lamp; 6000° K, 1000 hours.
Lamp brightness	1700 lumens
Exciter lamp	4V — 0.75A, BRK.
Standard lens	50mm (2") f/1.2, 6-element, coated.
Cinemascope lens holder	"C" size standard equipment ("D" size available).
Shutter	2 blade.
Construction	Modular.
Motor	Induction, with capacitor (plug-in module).
Film speed	24 fps sound. 18 FPS Available
Loop restorer	Automatic.
Control switch	Single rotary lockout switch for forward, reverse and lamp on/off.
Rewind	High speed. No reel or arm change required.
Reel capacity	2000 feet (6000 feet optionally available — supply and take-up — no rewind — deleting front cover with built-in speaker).
Speaker	One 8" speaker built into removable front cover, with 65' speaker cord. Separate 2-way speaker with 12" bass and 6.5" treble also available.
Sound	Optical or optical and magnetic.
Amplifier	Solid-state (plug-in module). 20w RMS continuous.
Tone controls	Separate treble and bass.
Wow & flutter	0.2% average combined weighted.
Size	14" x 12" x 14".
Weight	44 pounds (20kg).
Each projector is supplied with	Vinyl dust cover, cleaning kit, 9' power cord, 65' speaker cable and 2000' Eiki-matic take-up reel.

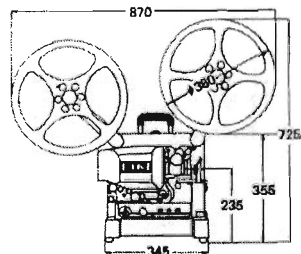

MAIN PARTS OF THE PROJECTOR

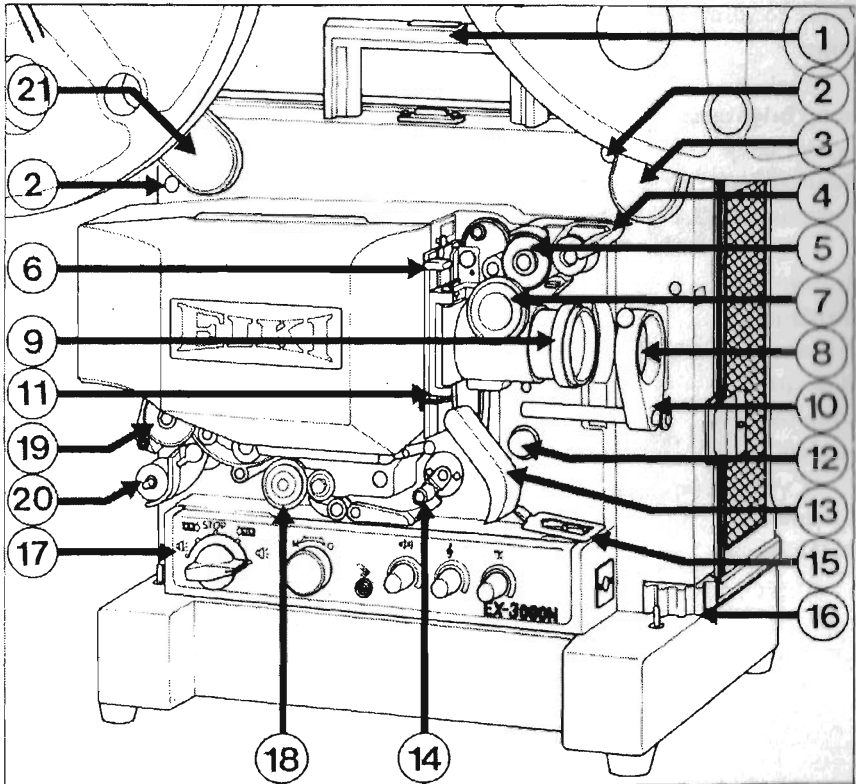

- | | |
|--------------------------------|---------------------------------------|
| 1. Handle | 12. Pilot lamp |
| 2. Arm lock | 13. Automatic threading control lever |
| 3. Supply arm | 14. Loop restorer |
| 4. Film channel & rewind lever | 15. Film trimmer |
| 5. No. 1 sprocket | 16. Elevator knob |
| 6. Stop lever | 17. Switch plate |
| 7. Focus knob | 18. Sound drum |
| 8. Inching knob | 19. No.2 sprocket |
| 9. Lens | 20. Tension guide roller |
| 10. Anamorphic lens holder | 21. Take-up arm |
| 11. Framing lever | 22. Lamp house |

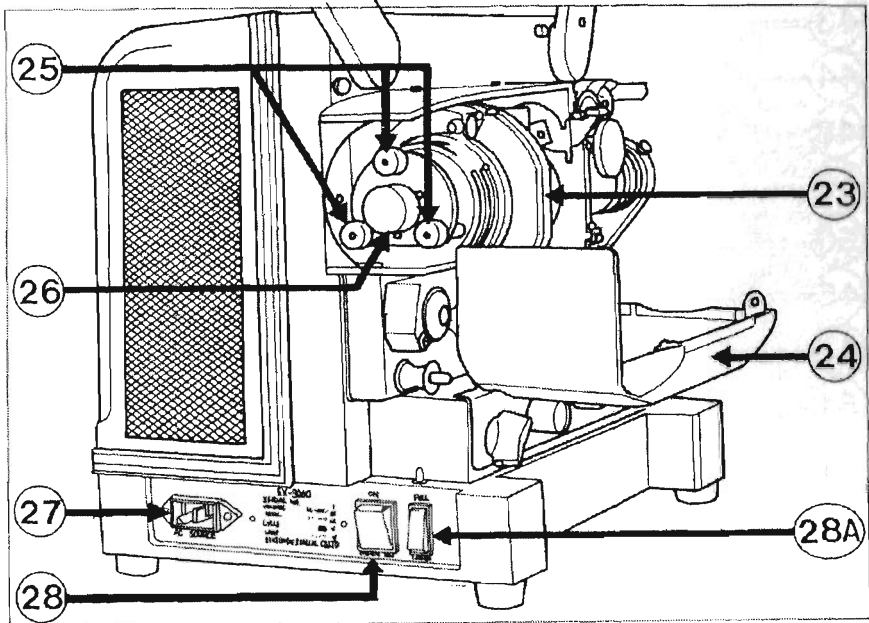

- 23. Mirror case
- 24. Lamp house cover
- 25. Lamp focusing screws

- 26. Insulation cap
- 27. AC receptacle
- 28. Main power switch
- 28A. Lamp intensity switch

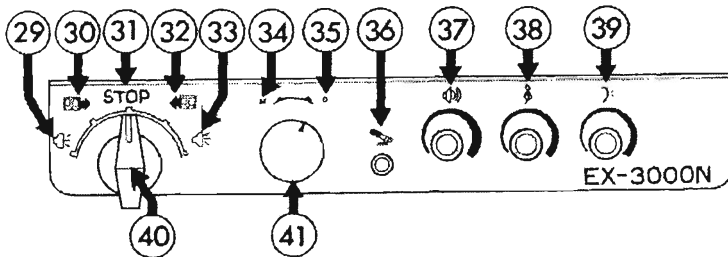

- 29. Lamp on (Reverse)
- 30. Reverse (On)
- 31. Stop (Off)
- 32. Forward (On)
- 33. Lamp on (Forward)
- 34. Magnetic playback
- 35. Optical playback

- 36. Microphone jack
- 37. Amplifier and volume knob
- 38. Treble control
- 39. Bass control
- 40. Function switch
- 41. Mag/Opt switch
(EX-3000N-2 only)

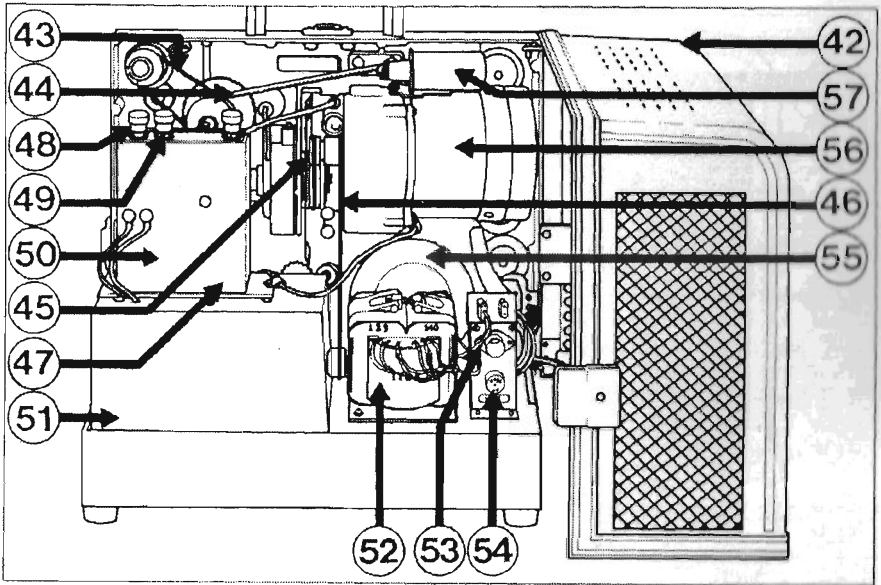

- | | |
|---------------------------------------|---------------------------|
| 42. Rear cover | 50. Starter high voltage |
| 43. Reverse belt (Same as motor belt) | 51. Rectifier |
| 44. Main drive belt | 52. Transformer |
| 45. Motor belt | 53. Voltage selector plug |
| 46. Rectifier fan belt | 54. Rectifier fuse (10A) |
| 47. Starter | 55. Flywheel |
| 48. Starter terminal (+) | 56. Motor |
| 49. Starter terminal (-) | 57. Motor condensor |

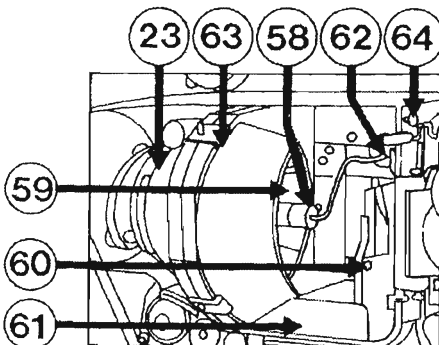

- | | |
|----|---------------------------|
| 23 | 58. Projection lamp |
| 63 | 59. Mirror |
| 58 | 60. Heat filter glass |
| 62 | 61. Exciter lamp cover |
| 64 | 62. Lamp terminal (+) |
| | 63. Lamp |
| | 64. Lamp house lock screw |

SETTING UP THE PROJECTOR

1. Lift latch to remove front cover

(CAUTION:

If lamp has not been installed proceed to the lamp installation instructions first before operating the projector.)

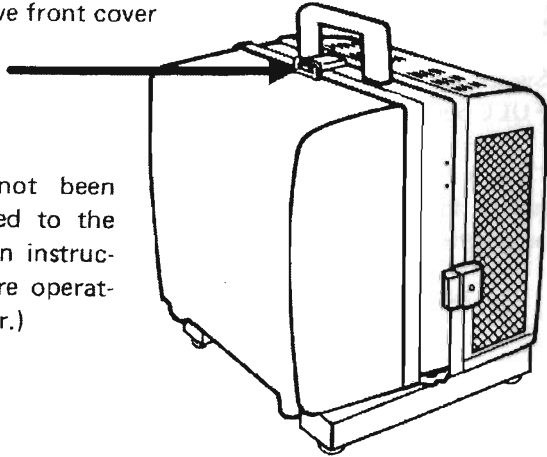

2. Raise both reel arms until they snap in place.

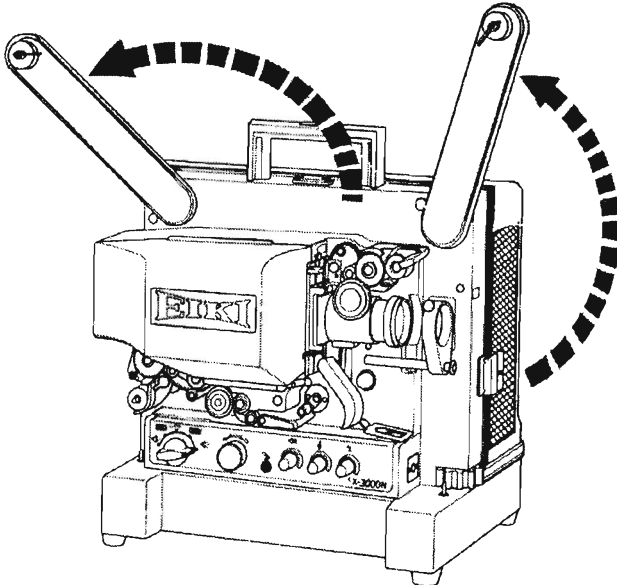

3. Connect power plug to proper outlet.



4. Switch "ON" main power

5. Switch Lamp Intensity Switch to FULL position

MAIN POWER SWITCH
LAMP INTENSITY SWITCH

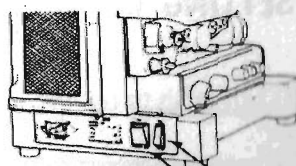

6. To turn lamp on, rotate function switch to the FORWARD lamp on position.

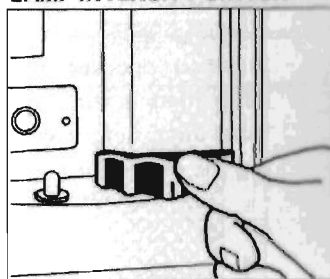
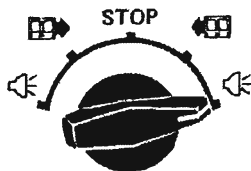

7. Position projector for the appropriate size image as desired. Adjust elevator knob to achieve the required image height. (See chart below for appropriate lens, distance and screen size.)

SCREEN SIZE CHARTS IN METERS

Distance		3m	5	10	15	20	25	30	40
Lens									
12.5mm	H	1.92	3.19	6.38	9.58				
	W	2.32	3.88	7.78	11.58				
25	H	1.96	1.80	3.19	4.79	6.38	7.98		
	W	1.16	1.93	3.86	5.79	7.72	9.65		
38	H	0.56	0.94	1.89	2.84	3.79	4.74	5.69	7.58
	W	0.76	1.26	2.53	3.80	5.07	6.34	7.61	10.15
50	H	0.43	0.72	1.44	2.16	2.88	3.60	4.32	5.76
	W	0.57	0.96	1.93	2.89	3.86	4.82	5.79	7.72
65	H	0.33	0.55	1.10	1.66	2.21	2.77	3.32	4.43
	W	0.44	0.74	1.48	2.22	2.96	3.71	4.46	5.93
76	H	0.28	0.47	0.94	1.42	1.89	2.37	2.84	3.79
	W	0.38	0.63	1.26	1.90	2.53	3.17	3.80	5.07
100	H	0.21	0.36	0.72	1.08	1.44	1.80	2.16	2.88
	W	0.28	0.48	0.96	1.44	1.93	2.41	2.89	3.86

SCREEN SIZE CHARTS IN INCHES

Distance		8'	10'	12'	16'	20'	25'	30'	35'	40'	45'	50'	60'	75'	100'
Lens															
.5"	H	4'0"	5'1"	6'1"	7'7"	10'2"									
	W	6'0"	7'7"	9'1"	11'4"	15'2"									
1"	H	2'2"	2'9"	3'4"	4'2"	5'7"	8'11"	8'4"	9'9"						
	W	2'11"	3'8"	4'5"	5'7"	7'5"	9'4"	11'3"	13'1"						
1.5"	H	1'8"	1'10"	2'2"	2'9"	3'8"	4'7"	5'7"	6'6"	7'5"	8'4"	9'4"			
	W	1'11"	2'5"	2'11"	3'8"	4'11"	6'2"	7'6"	8'9"	10'0"	11'3"	12'5"			
2.0"	H		1'4"	1'8"	2'1"	2'9"	3'6"	4'2"	4'10"	5'7"	6'3"	6'11"	8'4"	10'5"	13'11"
	W		1'10"	2'2"	2'9"	3'8"	4'8"	5'7"	6'6"	7'5"	8'5"	9'4"	11'3"	14'0"	18'9"
2.5"	H		1'0"	1'1"	1'6"	2'0"	2'6"	3'0"	3'8"	4'0"	4'6"	5'11"	6'1"	7'7"	10'2"
	W		1'6"	1'8"	2'3"	3'0"	4'6"	4'6"	5'3"	6'0"	6'10"	7'7"	9'1"	11'4"	15'2"
3.0"	H						2'3"	2'9"	3'3"	3'8"	4'2"	4'7"	5'7"	6'11"	9'3"
	W							3'1"	3'8"	4'4"	4'11"	5'7"	6'2"	7'5"	12'6"
4.0"	H							1'8"	2'1"	2'5"	2'9"	3'1"	3'5"	4'2"	6'11"
	W								2'3"	2'9"	3'3"	3'8"	4'2"	4'8"	7'0"

- 8. It is recommended that the projector be operated at an elevation not to exceed $\pm 10^\circ$ off the horizontal axis.
- 9. Adjust focus for clean and sharply illuminated screen.

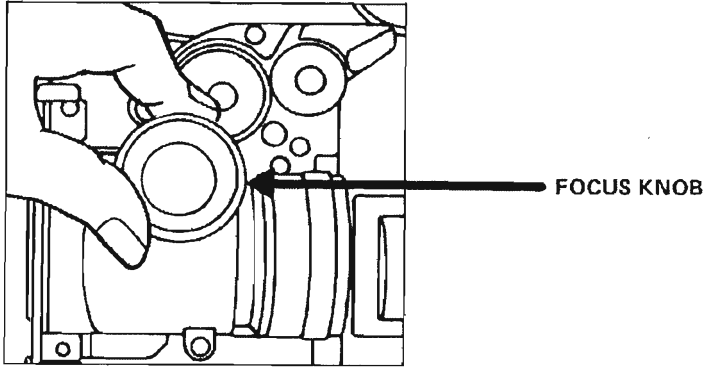

- 10. The lamp may be operated in either the FULL or HALF position depending upon the illumination requirements.

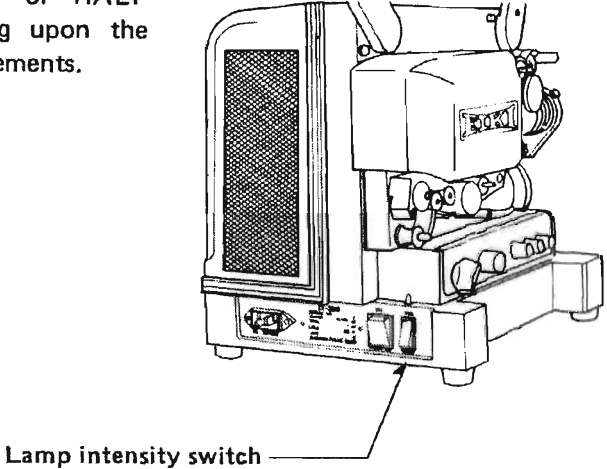

11. The extension 8" speaker located in the removable front cover may be placed near the screen and plugged into the jack marked "speaker" located on the front of the projector.

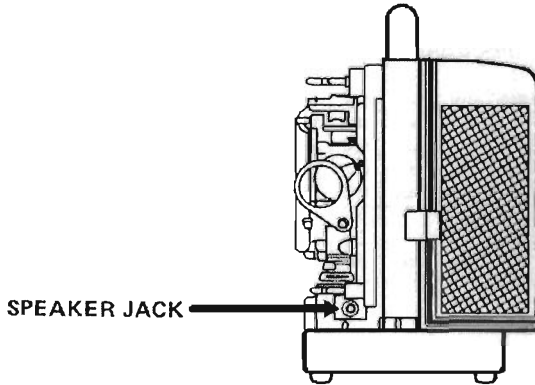
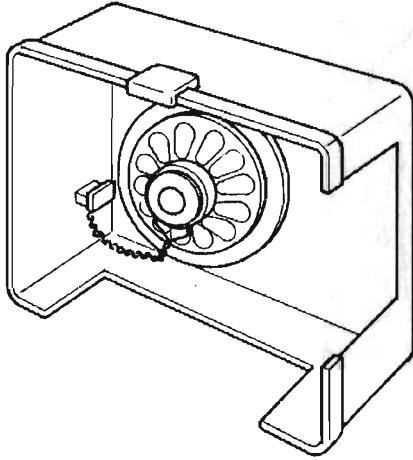

CAUTION: The 8 ohm speaker line must be maintained above electrical or earth ground to avoid a hum from a ground loop condition.

INSTALLING THE LAMP

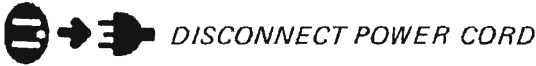

1. Loosen lamp house LOCK screw.

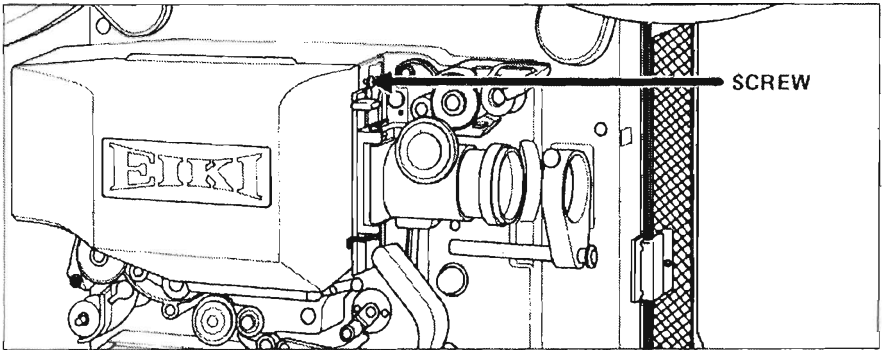

- 2. Open the lamp house cover by pulling from the top edge.
- 3. Remove the 7mm nut from the anode (+) terminal as shown using the nut driver provided.

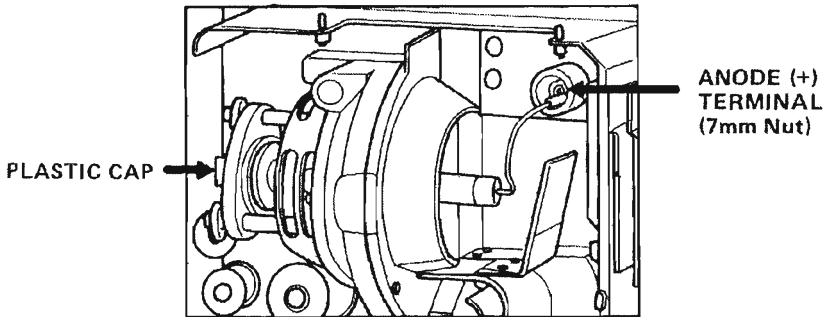

- 4. Unscrew the plastic cap from the cathode mounting terminal.
(**CAUTION:** XENON LAMPS ARE UNDER PRESSURE AND WILL EXPLODE IF HANDLED CARELESSLY. FINGER-PRINTS ON THE GLASS MAY LEAD TO EARLY LAMP FAILURE AND/OR PICTURE DEGRADATION. THEREFORE, PROTECT THE LAMP WITH A CLOTH OR HANDLE IT BY THE METAL ENDS ONLY.)

- Carefully remove the lamp from the carton.
- Holding the lamp by the metal ends, remove the knurled thumb nut from the cathode (-) end.

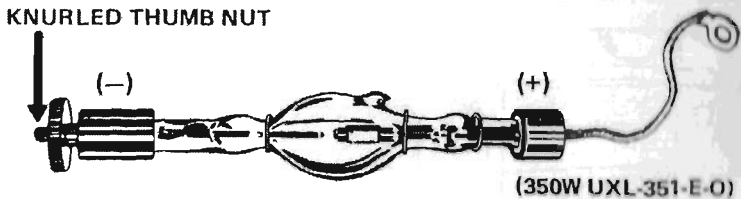

- With the fingers on the metal anode (+) end, insert the cathode (-) end into the center of the parabolic reflector.

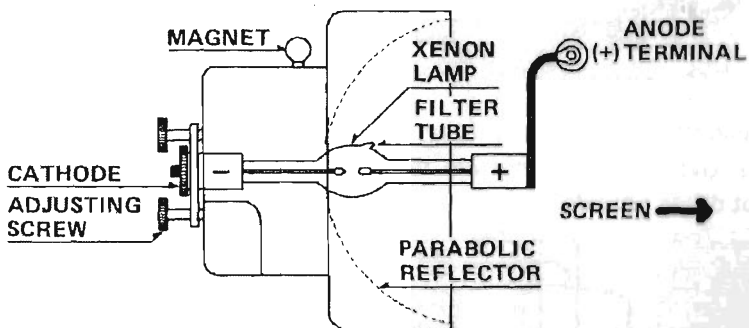

- The threaded cathode (-) end should now extend through the center hole in the rear of the reflector.
- Rotate the lamp until the filler tube points up.
- Locate the lug on the braided anode (+) lead and secure it to the anode (+) terminal using the 7mm nut previously removed.
- Secure the anode (+) lead with the nut driver provided.
- Position the braided anode cable (+) so that it forms a loop to the terminal away from the metal parts of the projector.
- Screw the knurled thumb nut on the cathode end (-) securing the lamp in the reflector.
- Should the glass have been touched accidentally, clean the touched area with the alcohol moistened towel provided.

ADJUSTING THE LAMP FOCUS

1. Position the projector for a screen image of at least 1m (3') wide.
2. With no film in the aperture, turn on the projector and lamp.
3. Adjust the focus for a clean, sharply illuminated screen.
4. Loosen the lamp house lock screw.
(CAUTION: Avoid looking directly at the Xenon lamp.)

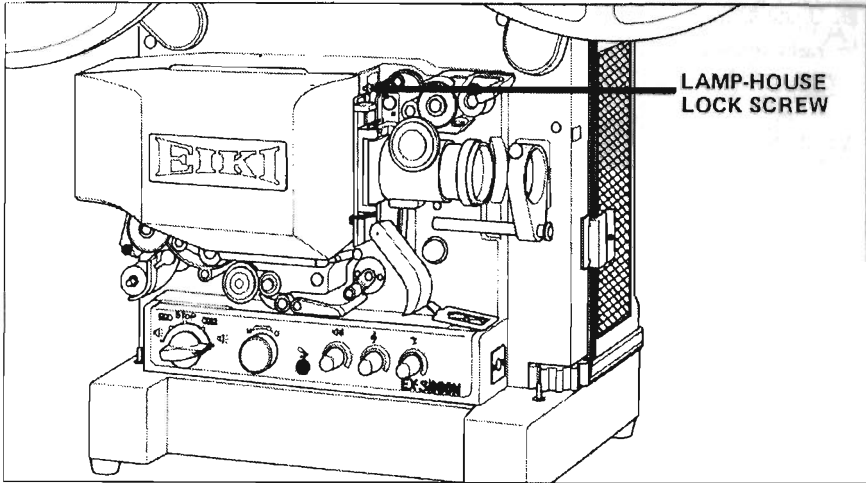

5. Open the lamp house cover by pulling from the top edge.
6. Locate the three knurled lamp adjusting screws behind the reflector.

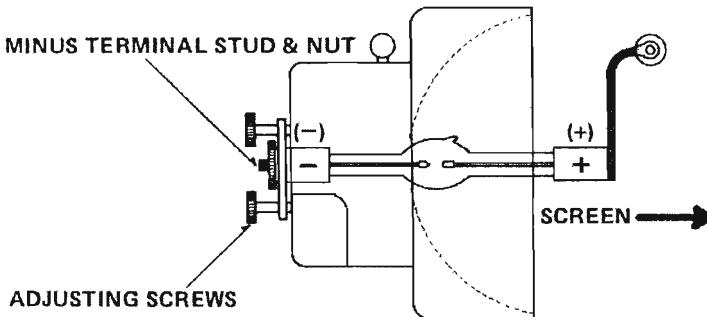

7. Turn the three adjusting screws, clockwise, one at a time until the maximum bright spot is located in the center of the screen.
8. Slowly turn each screw out, counterclockwise until the center bright spot is uniformly distributed over the entire screen with minimum reduction in brightness.
9. Once this adjustment has been made correctly, no further adjustment is necessary unless the lamp is removed or replaced.
(CAUTION: Focusing the bright spot through the lens for extended period of time may damage the lens.)

THREADING

1. Insert film in trimmer and cut.
(Fig. A)

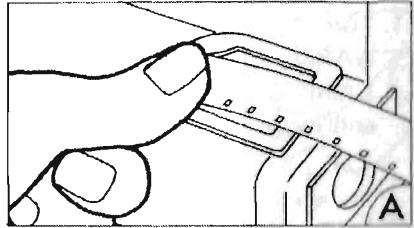

2. Turn function switch to FORWARD position ().

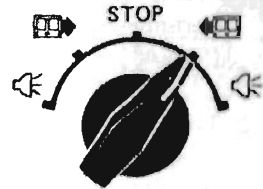

3. Push automatic threading control lever to SELF-THREAD position. Insert film leader into Film channel. (Fig. B) Film threads automatically.

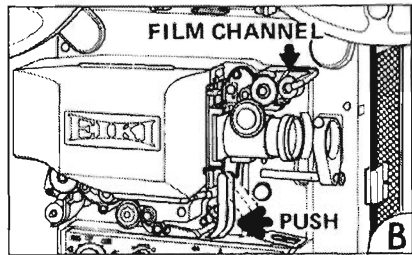

4. When a gentle tug is applied to film coming off last roller, the automatic threading guides will release.
(Fig. C)

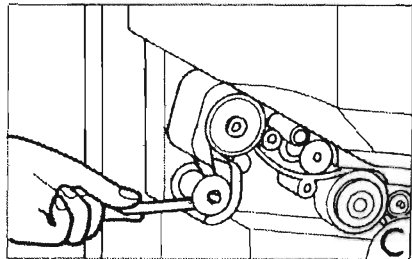

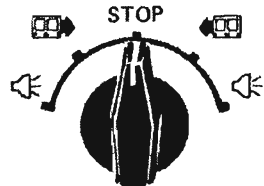

5. When sufficient film has passed through projector to reach take-up reel, return the function switch to STOP.



6. Attach leading edge of film on to take-up reel.

PROJECTING

1. Turn function switch to FORWARD position () and LAMP on position ( , ) and focus.

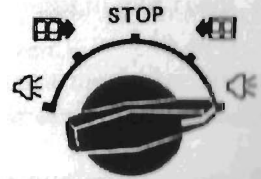

2. Frame film by adjusting the framing lever. (Fig. A)

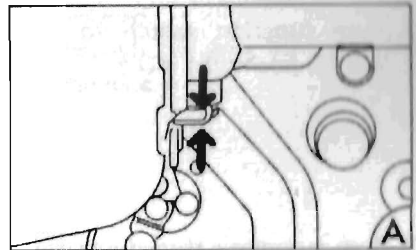



3. Turn volume switch on and adjust tone controls for a clear, pleasing sound.



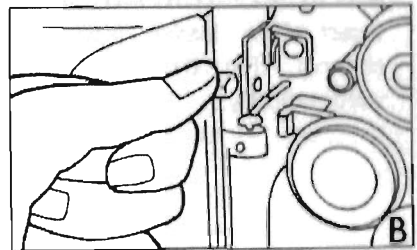

4. For pause, depress STOP LEVER (Fig. B).

NOTE: Stop lever is intended for short term cuing only.

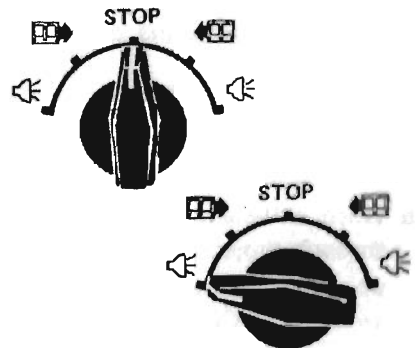

5. For REVERSE PROJECTION, turn function switch from STOP position to REVERSE () and LAMP on Position ().



6. When film is completed, turn function switch to FORWARD-position () and let motor run until all the film is on the take-up reel.

REWINDING

1. Attach tail end of film to the supply reel.
2. Move rewind lever DOWN to REWIND position (Fig. A) and turn function switch to REWIND (FORWARD) position (←↻). After rewinding, FIRST return rewind lever UP to OPERATE position and turn function switch to STOP position.

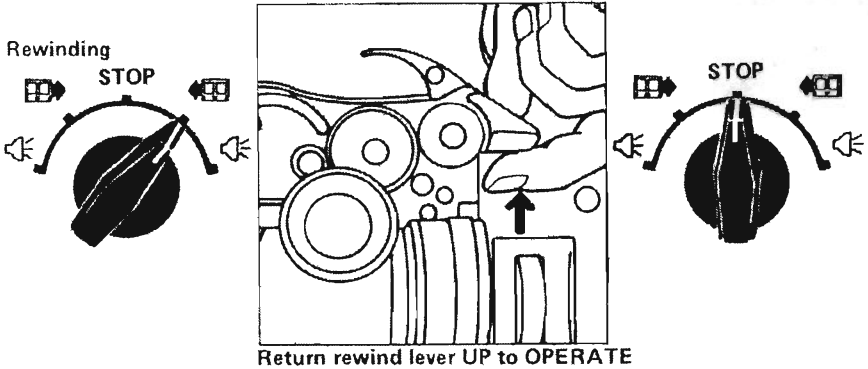
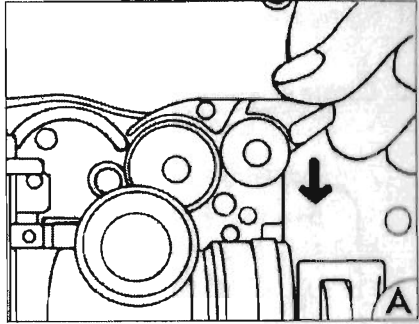

3. After removing reels from the arms, depress arm locking buttons (Fig. B) and lower arms.

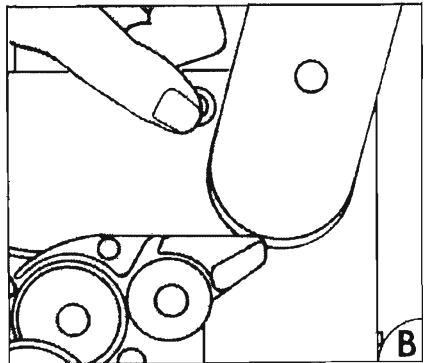

REMOVING THE LENS

(WITH ANTI-THEFT SCREWLOCK-U.S.A. only)

1. Swing open the lens holder and film gate.
2. Locate and remove the anti-theft screw.

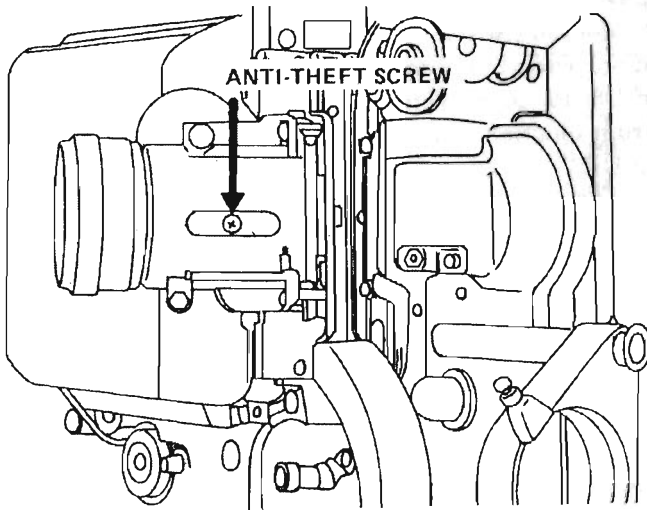

3. The lens can now be removed by turning the focus knob until lens is free.
4. To reinstall the lens, reverse the above procedure. Telephoto and wide-angle lenses can be installed in the same manner except that they do not have the anti-theft screw.

RECOMMENDED SPARE PARTS AND ACCESSORIES

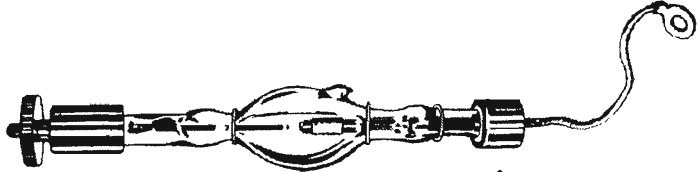

↑
Spare Xenon Lamp
350 Watt UXL-351-E-O
P/N 5107

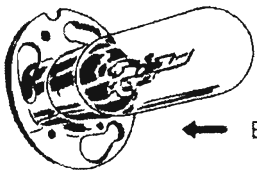

← Exciter Lamps BRK/4V 0.75 amp
P/N 5104



← Fuse 2 amp
(Exciter lamp)

P/N F02-5020



↑ P/N F02-6030
Fuse 2 amp (Amplifier)

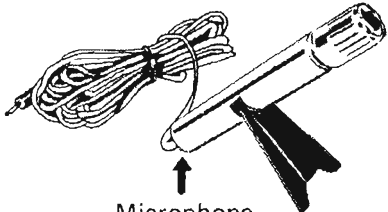

↑
Microphone
P/N 5460

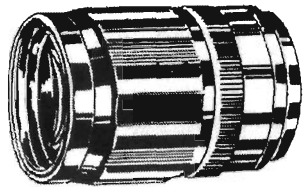

↑ P/N 5024

Zoom lens attachment
(Continuously variable from 38mm (1-1/2")
to 65mm (2-1/2") with standard prime lens)

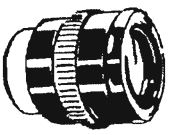

↑
Anamorphic lens
P/N 5030

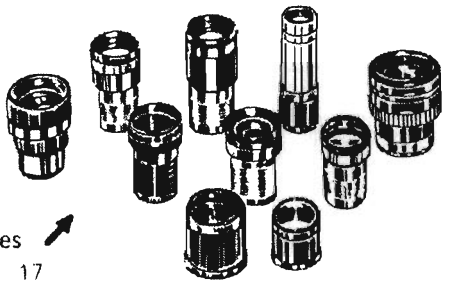

Additional lenses →

ORDER # ADDITIONAL LENSES AVAILABLE

5059	12.5mm (1/2")	F1.4
5060	25.0mm (1")	F1.5
5061	38.0mm (1-1/2")	F1.5
5019	50.0mm (2")	F1.2
5062	65.0mm (2.5")	F1.5
5063	75.0mm (3")	F1.8
5064	75.0mm (3")	F1.8 Tele-cine Lens
5066	100. mm (4")	F2.2
5024	Zoom Conversion Lens (.75 to 1.25 x Prime Lenses from 38mm to 75mm)	
5067	Zoom lens (.75 to 1.3 x Prime Lenses from 25mm to 75mm)	
5026	Wide-angle or Telephoto Conversion (.8 or 1.25 x Prime Lenses from 38mm to 75mm)	

SPECIAL APPLICATIONS

A. USING PROJECTOR AS A P.A. SYSTEM

Using projector as a P.A. system, simply plug an accessory microphone into the amplifier mic jack.

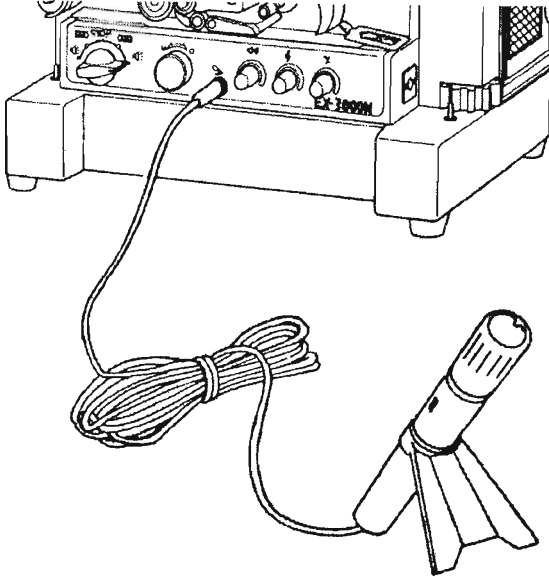

Turn on the amplifier and adjust the volume and tone controls as necessary.

NOTE: It is recommended that the P.A. mic be used with the projector plugged into the external speakers, and that the speakers be located away from the projector.

B. MAGNETIC SOUND TRACK PLAYBACK (EX-3000N-2 ONLY)

1. To reproduce a previously recorded magnetic sound track, turn the Opt/Mag switch to the (M) position. The projector may then be operated as usual.

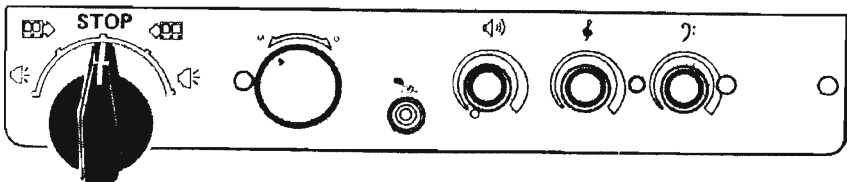

C. 50HZ TO 60HZ CONVERSION

The standard EX-3000N projector is available either as 50Hz or 60Hz sound speed operation. It is possible to change frequency by simply shifting the motor drive belt.

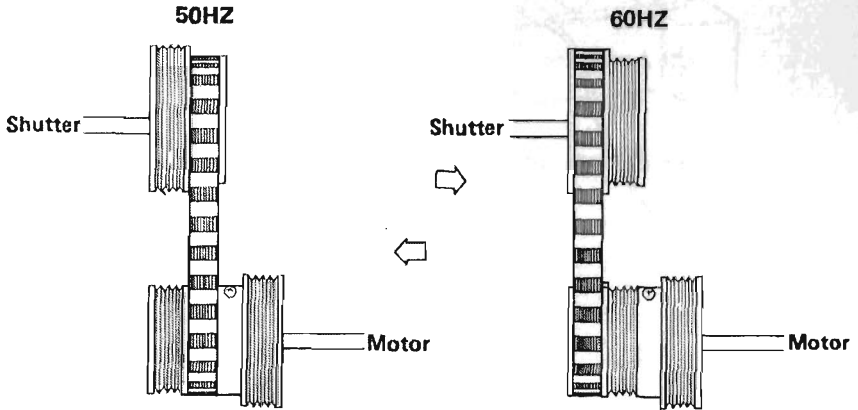



DISCONNECT POWER CORD

D. UNIVERSAL VOLTAGE SELECTION

- (1) Operating voltages for the projector may be selected from 100VAC to 240VAC.
- (2) To select the most appropriate voltage, open the rear cover, by first loosening the two lock screws and opening the latch.

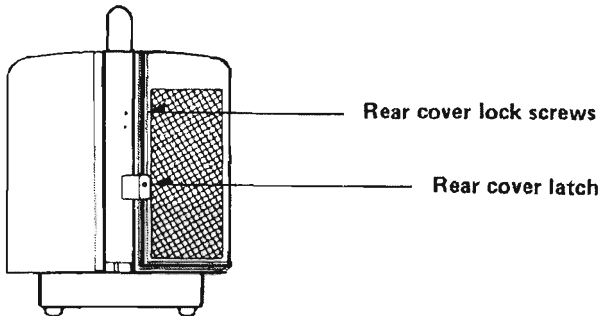

- (3) Locate the voltage selector bracket, select the proper range by the location of the two pin nylon connector.
- (4) Pull out the voltage selector plug, and re-position until the voltage value nearest the line voltage desired is displayed in the small notch.

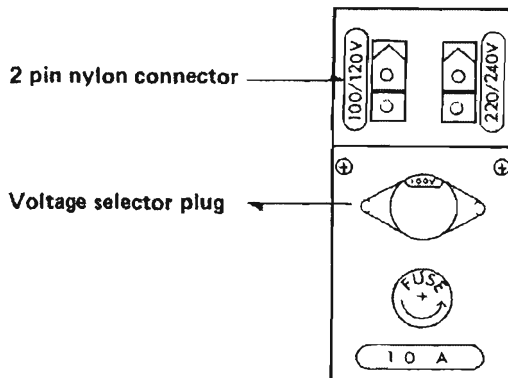

E. SILENT FILM OPERATION

Standard models are supplied with 50/60Hz pulleys, and optional 18 fps silent pulley is available for silent film operation.



1. DISCONNECT POWER SUPPLY CORD.

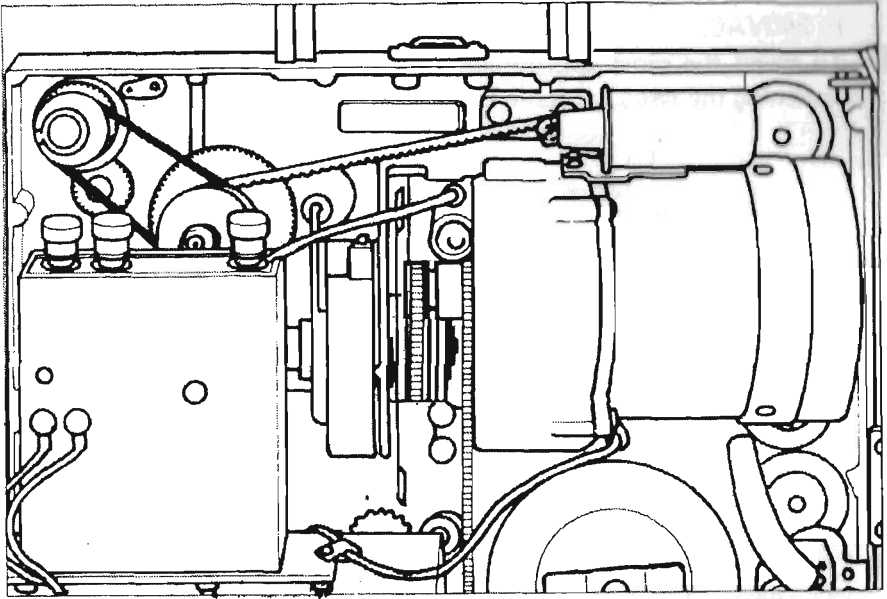

2. Open rear cover, Turn inching knob, at the same time guiding the belt first to the smaller motor pulley, then to the larger shutter pulley.
3. To change back to sound speed reverse the procedure.

NOTE; 50/60HZ models do not have silent speed.

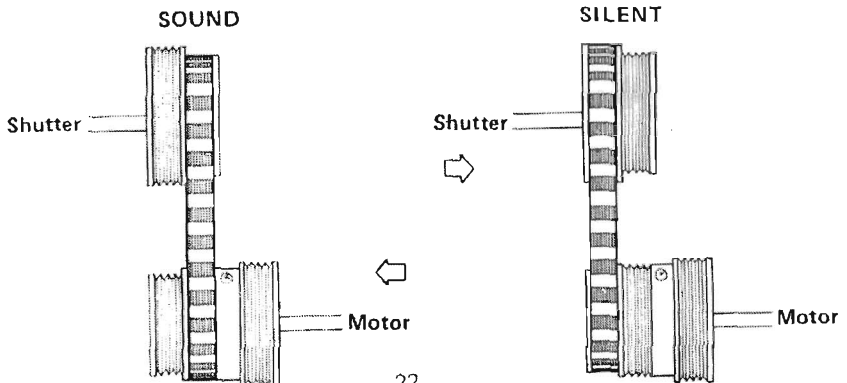

CLEANING AND MAINTENANCE

The EIKI projector has been designed to provide years of trouble free services.

All maintenance such as lubrications and adjustments should be referred to a qualified EIKI service technician.

To keep your projector looking and operating like new the following items should be checked and cleaned by the operator.

1. Lens – Clean with soft lens tissue.

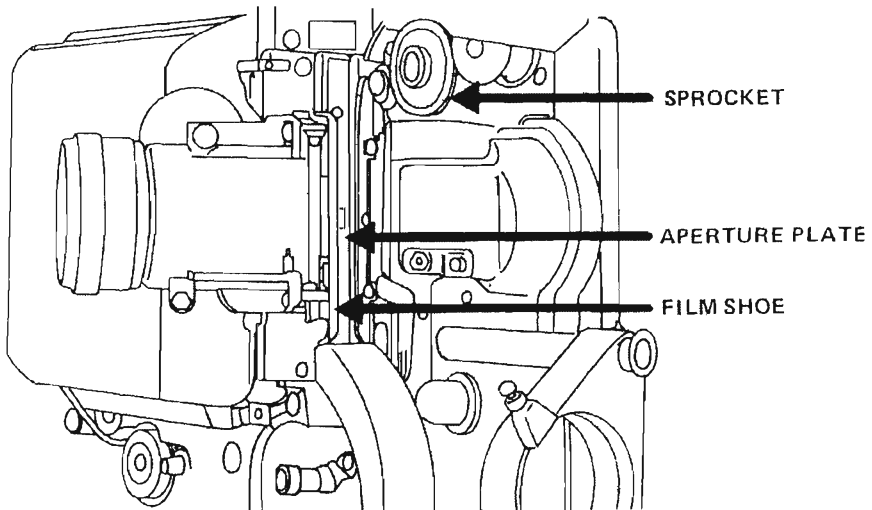

2. Film gate and aperture plate – Remove and clean with a soft brush.
3. Film rollers – Clean with isopropyl alcohol and wipe dry.
4. Sound focus lens – Brush or blow off dust and lint.
5. Projector: Wipe off with a damp cloth and keep closed when projector is not in use.

The front elevated feet should always be up before transporting or storing the projector.

Do not oil or lubricate any part of this projector. Refer to your authorized EIKI dealer.

OPERATOR TROUBLESHOOTING GUIDE

SYMPTOM	CHECK
No power to motor or lamp (Pilot lamp not on)	<ol style="list-style-type: none"> 1. Be sure projector is plugged in and the outlet has power 2. Check power cord 3. Check main power switch
Motor runs but film doesn't advance	<ol style="list-style-type: none"> 1. Motor belt off or broken 2. Check position of stop lever
Motor runs too fast or too slow	<ol style="list-style-type: none"> 1. Belt not on the correct motor pulley
Motor runs, film advances, lamp does not come on	<ol style="list-style-type: none"> 1. Function switch not in lamp position 2. Defective lamp 3. Check lamp rectifier circuit breaker 4. Check 10 amp lamp supply fuse 5. Defective lamp supply-Refer to authorized EIKI dealer
Won't thread properly	<ol style="list-style-type: none"> 1. Film channel and rewind lever not in the operate position 2. Film gate not properly closed 3. The automatic threading control lever not pushed to the thread position 4. Film not trimmer
No sound (Exciter lamp on)	<ol style="list-style-type: none"> 1. Amplifier volume control not turned up 2. On magnetic playback models make sure switch is in the correct position 3. 2 amp amplifier fuse defective
No sound (Exciter lamp not on)	<ol style="list-style-type: none"> 1. Amplifier volume control not turned on 2. Defective exciter lamp 3. 2 amp exciter lamp fuse defective 4. Amplifier not plugged in

SYMPTOM	CHECK
Poor sound	<ol style="list-style-type: none"> 1. Check position of volume control 2. Check position of tone controls 3. Check for correct exciter lamp (BRK) 4. Check for dirt in the solar cell 5. Check film, may be defective 6. Clean exciter lamp 7. Incorrect exciter lamp 8. Speaker defective
Poor picture	<ol style="list-style-type: none"> 1. Clean film gate and aperture 2. Clean lens with a soft tissue both front and rear 3. Refocus lens 4. Film may be defective
Poor Illumination	<ol style="list-style-type: none"> 1. Lamp incorrectly aligned (See lamp adjustment procedure) 2. Defective lamp
Excessive lamp flicker	<ol style="list-style-type: none"> 1. Defective lamp 2. Incorrect projector elevation

EIKI INDUSTRIAL CO., LTD.

C.P.O. Box 1229, Osaka 530-91, Japan

EIKI INTERNATIONAL, INC

27882 Camino Capistrano, Laguna Niguel, California 92677

Tel: 714/831-2511 · Telex: 685-638

PRINTED IN JAPAN

IMPORTANT SAFEGUARDS

When using your EIKI 16mm projector, basic safety precautions should always be followed, including the following:

1. Read and understand all instructions.
2. Close supervision is necessary when any equipment is used by or near children. Do not leave projector unattended while in use.
3. Xenon lamps are under extreme pressure. Care must be exercised when installing or removing the lamp. Do not remove while hot. Refer to lamp installation instructions.
4. Do not operate projector with a damaged cord or if the projector has been dropped or damaged — until it has been examined by a qualified service technician.
5. Do not let the cord hang over edge of the table or counter or touch hot surfaces.
6. If an extension cord is necessary, a cord with a suitable current rating should be used. Cords rated for less amperage than the projector may overheat. Care should be taken to arrange the cord so that it will not be tripped over or pulled.
7. Always unplug projector from electrical outlet when not in use. Never yank cord to pull plug from outlet. Grasp plug and pull to disconnect.
8. Let projector cool completely before putting away. Return cord to cord storage space provided when storing projector.
9. To protect against electrical shock hazards, do not operate this projector in the rain or when wet.

IMPORTANT SAFEGUARDS (cont'd)

10. To avoid electric shock hazard, do not disassemble this projector, but refer to a qualified service technician when service or repair work is required. Improper repairs or reassembly can cause electric shock hazard.
11. Do not remove lamphouse cover when projector motor is running.
12. Observe the caution plate by rear cover latch "DISCONNECT POWER SUPPLY BEFORE OPENING".
13. Do not look directly at an operating lamp with unprotected eyes.

SAVE THESE INSTRUCTIONS

EIKI



Hugh McCullough
Projector Drive Belts & Manuals
For 8mm - 9.5mm - 16mm machines

52. Ellis Road
Old Coulsdon
Surrey. CR5 1BZ
Phone:01737 554676

E-mail:kalee12@fsmail.net
Website:www.cineinfo.co.uk