

FILM-TECH

THE INFORMATION CONTAINED IN THIS ADOBE ACROBAT PDF FILE IS PROVIDED AT YOUR OWN RISK AND GOOD JUDGMENT.

THESE MANUALS ARE DESIGNED TO FACILITATE THE EXCHANGE OF INFORMATION RELATED TO CINEMA PROJECTION AND FILM HANDLING, WITH NO WARRANTIES NOR OBLIGATIONS FROM THE AUTHORS, FOR QUALIFIED FIELD SERVICE ENGINEERS.

IF YOU ARE NOT A QUALIFIED TECHNICIAN, PLEASE MAKE NO ADJUSTMENTS TO ANYTHING YOU MAY READ ABOUT IN THESE ADOBE MANUAL DOWNLOADS.

WWW.FILM-TECH.COM



MODEL 804, 805, 806 AND 807
DUO EIGHT MOVIE PROJECTOR
INSTRUCTIONS

automatic threading

PROJECTS EITHER STANDARD 8mm OR SUPER 8 FILM

IMPORTANT SAFEGUARDS

When using your photographic equipment, basic safety precautions should always be followed, including the following:

1. Read and understand all instructions.
2. Close supervision is necessary when any appliance is used by or near children. Do not leave appliance unattended while in use.
3. Care must be taken as burns can occur from touching hot parts.
4. Do not operate appliance with a damaged cord or if the appliance has been dropped or damaged—until it has been examined by a qualified serviceman.
5. Do not let cord hang over edge of table or counter or touch hot surfaces.
6. If an extension cord is necessary, a cord with a suitable current rating should be used. Cords rated

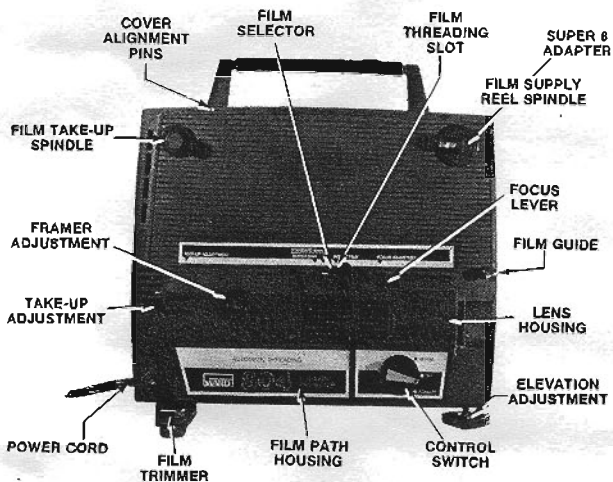

MODEL 804

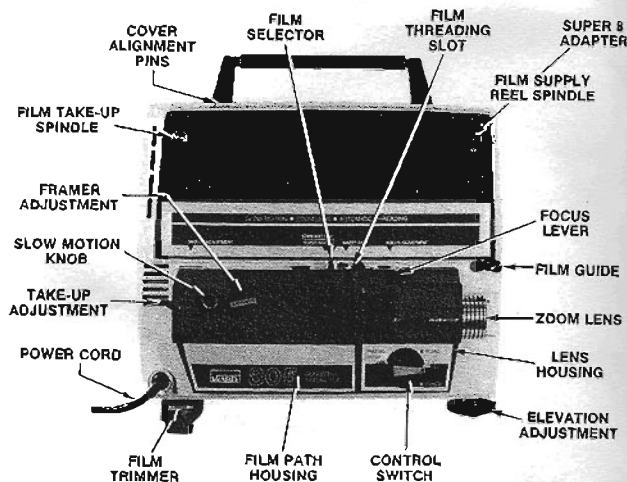

MODEL 805

for less amperage than the appliance may overheat. Care should be taken to arrange the cord so that it will not be tripped over or pulled.

7. Always unplug appliance from electrical outlet when

not in use. Never yank cord to pull plug from outlet. Grasp plug and pull to disconnect.

8. Let appliance cool completely before putting away. Loop cord loosely around appliance when storing.

9. To protect against electrical shock hazards, do not immerse this appliance in water or other liquids.

10. To avoid electric shock hazard, do not disassemble this appliance, but take it to a qualified serviceman when

some service or repair is required. Incorrect reassembly can cause electric shock hazard when the appliance is used subsequently.

SAVE THESE INSTRUCTIONS

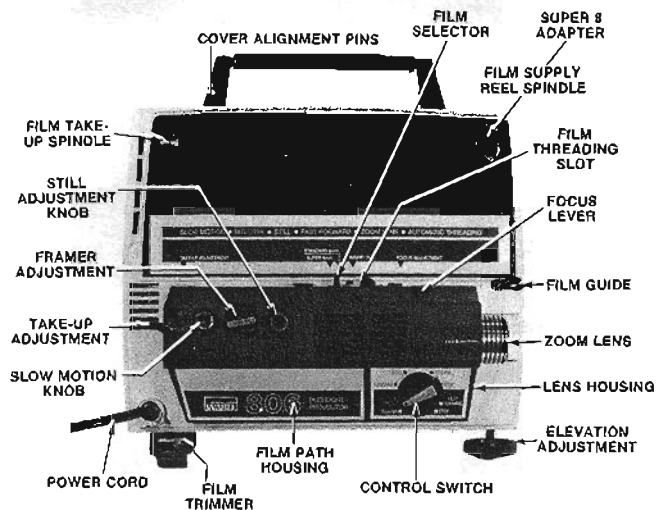

MODEL 806

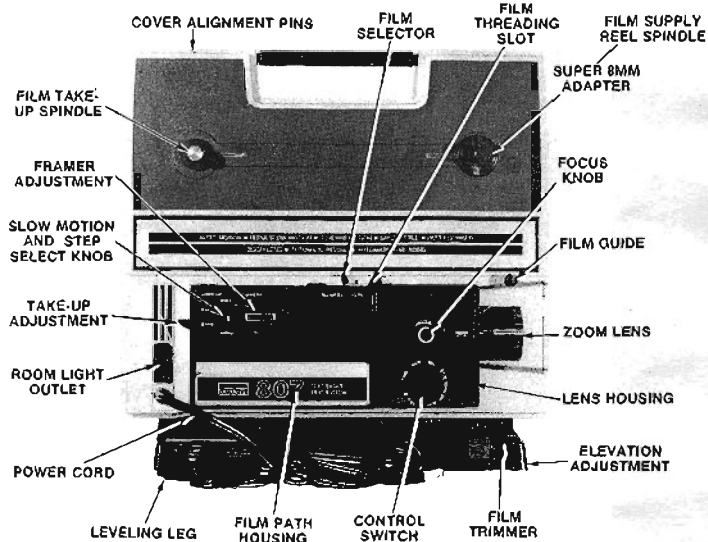

MODEL 807

SETTING UP YOUR PROJECTOR

1. Place projector on stand, table or other firm support of convenient height.
2. Remove cover by pushing up on bottom latch and pulling out on bottom of cover. Note that cover alignment pins at top of projector case fit into holes in projector cover.
3. Unwind power cord from reel spindles and plug into wall outlet. Use 110/120 volt, 60 cycle A.C. electrical outlets only.
4. Remove take-up reel from projector cover and place on film take-up spindle with slotted center hole of reel toward projector. Rotate reel and fit slot over the spindle key, then push firmly to lock in place.
5. Set up screen at desired projector distance.
6. Set film selector to Standard 8 or Super 8, depending on your film.
7. Turn control switch to FORWARD.
8. Center light area on the screen vertically by turning elevation adjustment knob and horizontally by moving the projector. Move the focusing lever (Fig. 1) (Models 804, 805 and 806) forward or backward or turn focus knob (Fig. 2) (Model 807) clockwise or counter-clockwise until margins of the lighted area

are sharp on the projection screen. Line up so both sides of projected image can be brought into sharp focus.

9. Turn projector OFF.

PROJECTION DISTANCE TABLE

Screen Width	PROJECTOR-TO-SCREEN DISTANCE			
	STANDARD 8		SUPER 8	
	Fixed Lens	Zoom Lens	Fixed Lens	Zoom Lens
24 in.	10 ft.	8 ft. to 13 ft.	9 ft.	7 ft. to 11 ft.
30 in.	13 ft.	10 ft. to 17 ft.	11 ft.	9 ft. to 14 ft.
40 in.	17 ft.	14 ft. to 22 ft.	14 ft.	12 ft. to 20 ft.
50 in.	21 ft.	18 ft. to 28 ft.	17 ft.	15 ft. to 25 ft.

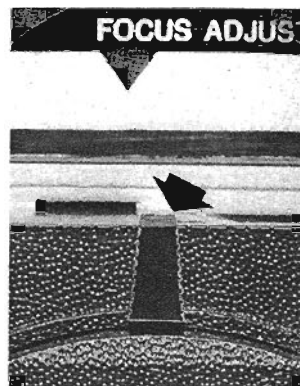

FIG. 1

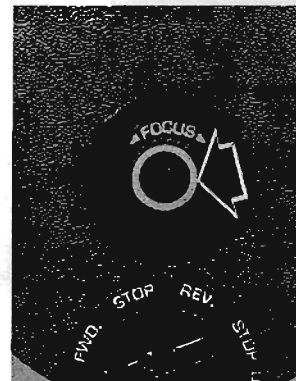
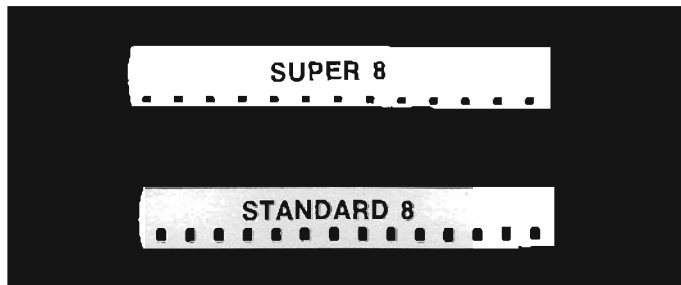

FIG. 2



FILM IDENTIFICATION GAUGE

Lay film on gauge to determine type. Film slots must line up with dots on gauge.

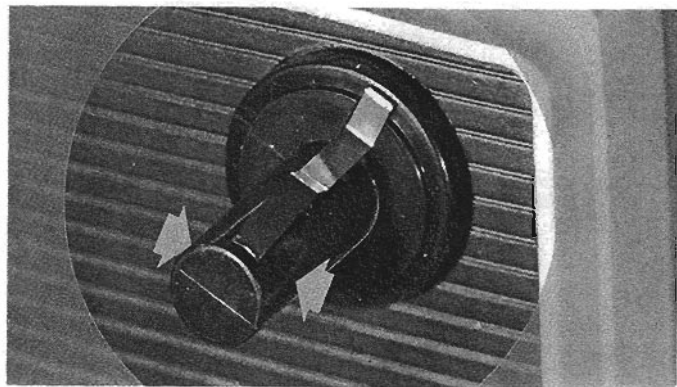

FIG. 3

PROJECT EITHER STANDARD 8MM OR SUPER 8 MOVIES

With just two simple adjustments, either standard 8mm or Super 8mm movies can be conveniently shown with the WARDS Movie Projector.

The same take-up reel is used for both standard 8mm and Super 8mm film. No adaptation is required.

TO SHOW STANDARD 8MM MOVIES

Move the film selector switch forward to the STANDARD position as marked on the projector.

Remove the adapter by first pushing slightly to release the spring catch, then pulling the adapter off (Fig. 3). With the adapter removed, the film supply spindle will take standard 8mm film reels. The projector is now ready to show standard 8mm movies.

TO SHOW SUPER 8 MOVIES

Move the film selector switch to the rear SUPER 8 position as marked on the projector.

Push the adapter *all the way* on the supply spindle. It will now accept Super 8 reels.

The same take-up reel is used for both standard 8mm and Super 8 film.

The projector is now ready to show Super 8 movies.

NOTE: THE SELECTOR MUST BE IN THE PROPER POSITION, OTHERWISE THE SELF-THREADING MECHANISM WILL NOT WORK PROPERLY AND DAMAGE TO THE FILM MAY RESULT. If standard 8mm film is projected with the selector switch in the Super 8 position, film perforations will appear on the left edge of the screen image. If Super 8 film is projected with the selector switch in the standard 8mm position, the edges of the picture will be cut off since the Super 8 image is larger than the standard 8mm image.

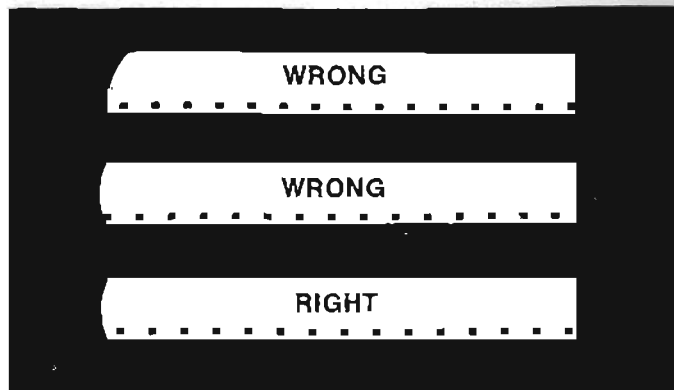

FIG. 4

AUTOMATIC FILM THREADING

1. Place reel of film on the front supply spindle so that the reel slot engages the spindle key when fully seated. Film will feed clockwise off of the reel with the perforated edge farthest from the body of the projector.
2. Trim end of film with trimmer on projector base (Fig. 5 and 6). Proper film trimming is essential for automatic threading (Fig. 4).
3. Bring end of film down from supply reel and under film guide (Fig. 7).
4. With projector in OFF position, feed about two inches of trimmed film into the threading slot (Fig. 7).

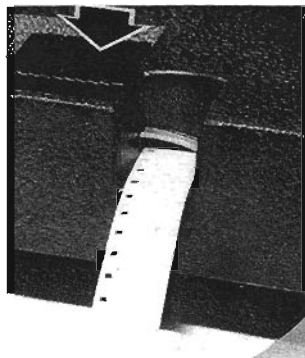

FIG. 5

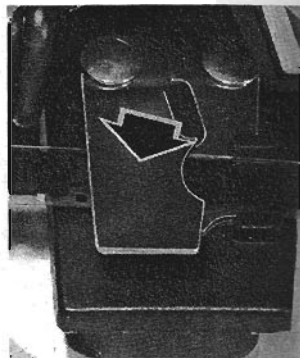

FIG. 6

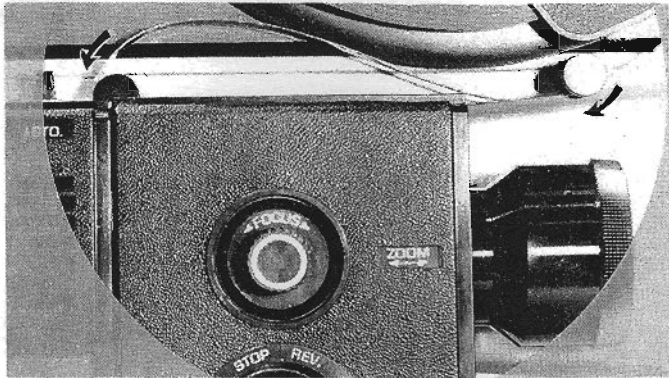

FIG. 7

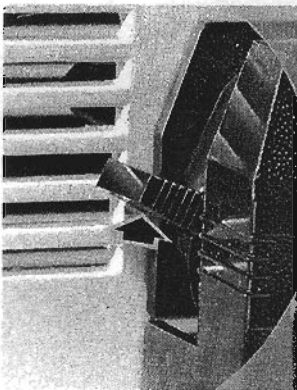

FIG. 8

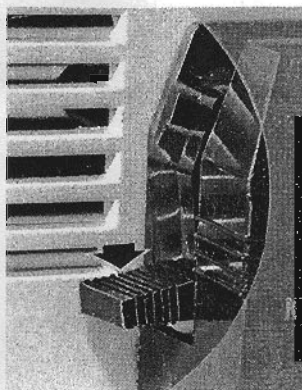

FIG. 9

5. Turn control switch to FORWARD position. Be sure that the slow motion knob is in NORM position.

IF THE FILM DOES NOT FEED INTO PROJECTOR, CHECK THE FOLLOWING:

- Film end not trimmed correctly.
 - Film selector in wrong position (Standard 8 or Super 8).
 - Film end not far enough into film threading slot.
 - Film path housing not latched in place.
 - Projector not in OFF position (see 4 above).
 - Slow motion knob not in NORM position.
6. Film will thread automatically through the film path on to the take-up reel.

If film comes out of take-up adjustment slot too straight to feed on core of take-up reel, push take-up adjustment lever up (Fig. 8).

If film comes out of take-up adjustment slot with too much curl and feeds below core of take-up reel, push take-up adjustment lever down (Fig. 9).

WARDS Projectors incorporate a unique film path buffer system which eliminates sprocket wheels and automatically adjust film tension. No film loops to form when threading or lost loops to reform during projection.

NOTE: Simplified instruction for film threading are printed inside projector cover for convenient reference.

FILM PROJECTION

1. Turn projector control switch to FORWARD position for normal movie projection.
2. Readjust focus until picture image is in sharp focus on the screen.
3. If a frame line or portion of next picture shows on the screen (Fig: 11), slowly turn framer adjustment knob (Fig. 10) until picture is centered.
4. If film stalls in the projector while operating, pull a few frames of film through projector by turning the take-up reel by hand.

CAUTION: Turn off projector immediately . . .

1. If film should break.
2. If film fails to feed properly.
3. At the end of projection if auto rewind fails to operate (Moael 807).

One frame of film may be damaged by heat if projection lamp is on with film stopped in other than STILL position (Model 806).

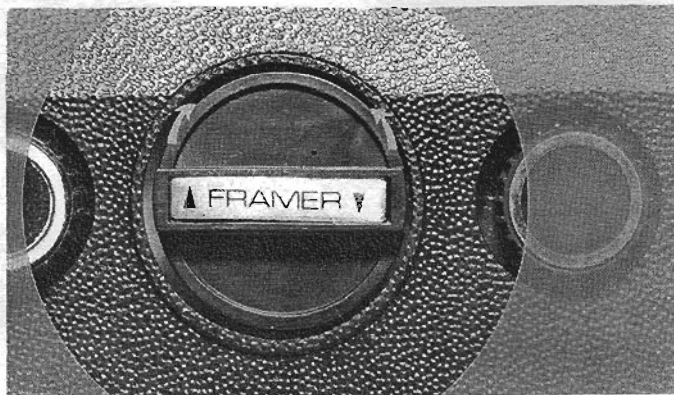

FIG. 10

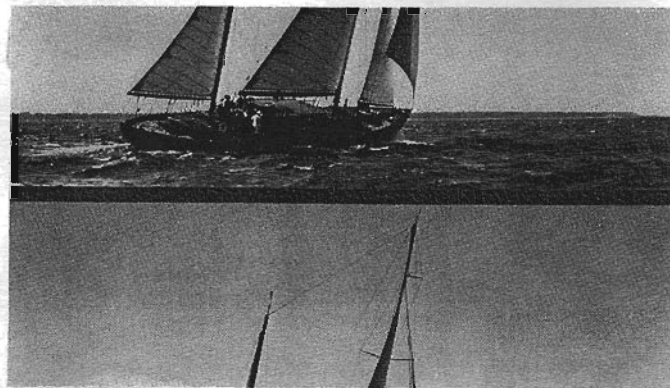

FIG. 11

STILL PROJECTION

(Model 806)

For still or single frame projection, turn control switch to STILL. If no picture appears on the screen or if the image is dim, turn the still adjustment knob (Fig. 12) in either direction until the picture is as bright as possible. Refocus the picture, if necessary. The still ad-

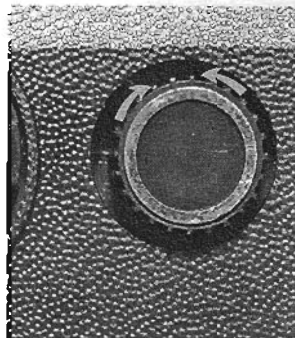

FIG. 12



FIG. 13

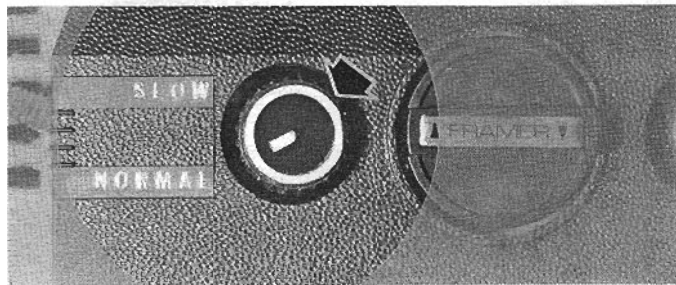

FIG. 14

justment knob may be used to advance the film one frame at a time when the control switch is in STILL position.

While individual frames are being viewed with still projection, a heat filter automatically protects the film from heat damage.

To resume normal projection turn the control switch to FORWARD or REVERSE as desired.

NOTE: The still adjustment knob rotates continually while the projector is operating.

SLOW MOTION PROJECTION

(Models 805 and 806)

Movies can be projected in slow motion at 6 frames per second, with one quick adjustment of the projector. Turn the film speed shift knob (Fig. 14) to SLOW while the projector is in FORWARD or REVERSE. To resume normal projection speed, turn the knob to NORMAL.

BRIGHT STILL AND STEP MOTION PROJECTION

(Model 807)

For still or single frame projection, turn knob (Fig. 13) to STILL and refocus the picture, if necessary. To resume normal projection turn the knob to NORM.

Movies can be projected in slow motion at 6 frames per second or 2 frames per second with one quick adjustment of the projector. Turn the film speed shift knob to 6 FPS or 2 FPS while the projector is in FORWARD or REVERSE. To resume normal projection speed, turn the knob to NORM (Fig. 13).

ZOOM LENS

(Models 805, 806 and 807)

With the zoom projection lens, the size of the picture can easily be adjusted without moving the projector or screen. First bring the picture into focus and then slide the zoom lens collar forward or backward (Fig. 15) to fill the viewing screen; refocus image if necessary.

ROOM LIGHT RECEPTACLE

(Model 807)

The room light receptacle (Fig. 16) turns off an external table or floor lamp when the projector is in FORWARD, STILL or REVERSE and automatically turns this lamp on when the projector is in OFF, STOP, FAST FORWARD or REWIND.

Room lights used with this receptacle should not exceed 150 total watts.

REVERSE PROJECTION

(Models 806 and 807)

Turn control switch to REVERSE. It may be necessary to re-frame the picture with the framer adjustment knob.

To resume normal projection, turn the control switch to FORWARD. To stop or shut off projector, turn the control switch to STOP or OFF.

NOTE: Use STOP position only temporarily.

Use OFF position when film is completed.

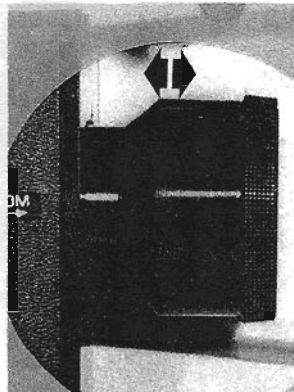

FIG. 15

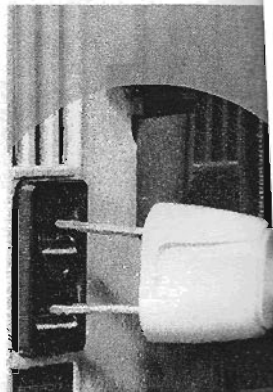

FIG. 16

FAST FILM ADVANCE

(Models 806 and 807)

To advance quickly to scenes remaining or to return to already projected scenes, turn control switch to FAST FORWARD or REWIND.

The projection lamp will be off in FAST FORWARD or REWIND positions.

NOTE: Turn the control switch positively from position to position, without stopping in between. This will prevent the film reels from free-wheeling and causing the film to spill.

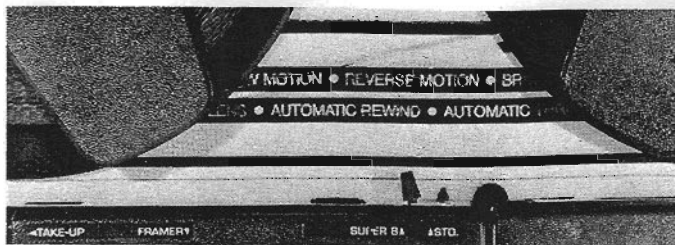

FIG. 17

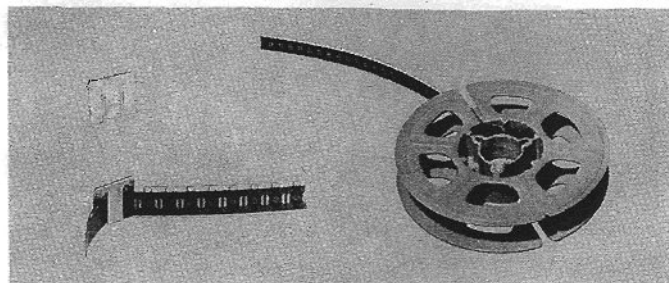
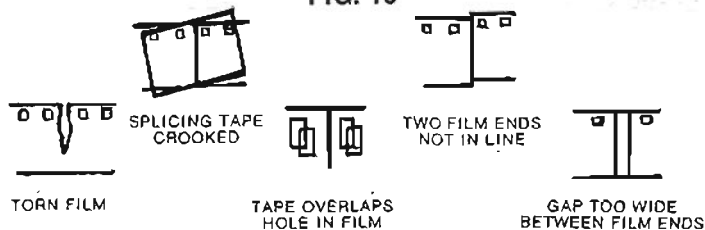

FIG. 18



INCORRECT FILM SPLICES

FIG. 19

REWINDING

After showing the film, rewind it back on the film supply reel so it is ready for the next showing.

If the end of film is still attached to supply reel, or to rewind film at any time during projection, turn control switch to REWIND.

If all of the film has passed through the projector, turn control switch to OFF or STOP (Models 806 and 807). By-pass the film path mechanism by threading film from take-up reel directly back to supply reel (Fig. 17). Attach film to supply reel by inserting film end into slot in reel core and rotating reel counterclockwise two turns. Turn control switch to REWIND. After film is completely rewound, turn projector OFF.

AUTOMATIC REWINDING

(Model 807)

Film can be projected and rewound automatically; the projector must be manually turned OFF after rewinding. For automatic rewinding, attach film to a supply reel and film tension will automatically trigger rewind cycle. If film is not secured to the supply reel, normal rewind procedures should be followed.

Attaching Film To Supply Reel With Film Clip: Attach rewind film clip to film end (Fig. 18). Extra clips are furnished with the projector or are available from your dealer. Insert end of film with film clip into side opening of supply reel and position clip inside reel core below core slot.

DAMAGED FILM

For trouble-free projection, film must be in good condition. Cut out bad sections of film which have torn perforations or are damaged. Make certain all splices are aligned and in good condition (Fig. 19).

AFTER THE SHOW

Do not jar the projector while the lamp is hot. Allow approximately one minute for the lamp to cool before moving the projector.

Remove reels and store take-up reel in front cover. Unplug room light (Model 807). Retract the power cord by pulling out and to the left and allow it to rewind into the projector base. Replace projector cover.

REPAIRING FILM BREAKS DURING PROJECTION

Turn control switch to OFF as quickly as possible, preventing further film damage. Use film trimmer on projector base to round off end of film from supply reel. Rethread film and turn control switch to FORWARD and run about a foot of film through projector. Turn projector OFF, splice film and resume projection.

BACKWARD ACTION AND UPSIDE DOWN PICTURES

If picture action is backward and pictures are upside down on the screen, the film has not been rewound after its last showing. Remove the full film reel from the supply spindle, place it on the take-up spindle, and rewind film on a spare supply reel. For correct projection, the film perforations must be farthest from the body of the projector. Emulsion or dull side of film should face the projection screen.

REMOVE FILM FROM AUTOMATIC THREADING MECHANISM

To remove film from film path of projector before all of the reel has been shown, first turn projector OFF and unplug power cord. Remove film path housing



FIG. 20

by squeezing simultaneously the top and bottom tabs and pulling out (Fig. 20). Carefully remove film from film path.

To install film path housing, position so top and bottom locking tabs are lined up with slots in projector body. Push firmly to secure tabs, making certain they snap into position.

CAUTION: Film may be damaged if film path housing is not latched in place.

CARE AND MAINTENANCE

1. CLEANING THE APERTURE PLATE AND FILM PATH

Turn projector OFF and unplug power cord. Remove film path housing (Fig. 20). Clean dust from aperture and film path (Fig. 21) with a soft brush, cotton swab or pipe cleaner.

2. CLEANING THE PROJECTOR LENS

A. Disassembly

(Models 804, 805 and 806)

Remove ribbed knob from focusing lever by pulling straight up. Pull off control knob, remove the screw and lift off lens housing. Unhook focus lever spring from notched hook on projector frame. Lift off focus lever and remove lens by pulling straight forward (Fig. 22).

(Model 807)

Remove lens by gently pulling out on the focus knob and at the same time pulling the lens toward front of projector. It is not necessary to remove the lens housing.

Clean the lens with a soft brush or carefully wipe with lens cleaning tissue. If moisture is required, breathe on the lens surface but do not use a wet cloth.

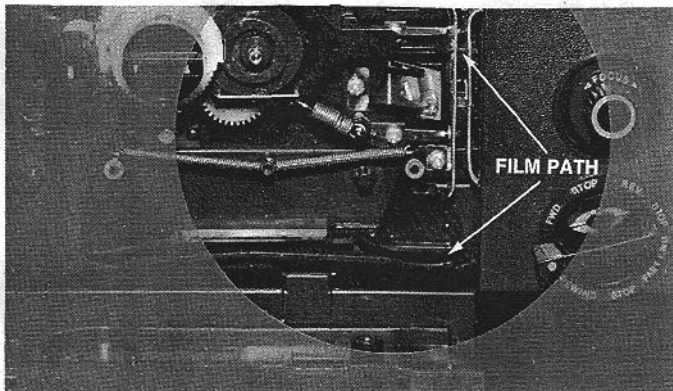

FIG. 21

B. Reassembly

Projectors with Fixed Focus Lens (Model 804)

Place focusing lever in vertical position, insert lens and hook spring under projector hook. Center threads on lens barrel directly under focusing lever (Fig. 22). Adjust focus for optimum projection distance by testing the projector about 12 feet from projection screen. Hold focusing lever in vertical position and rotate lens barrel until margins of lighted area are sharply defined on the screen. Replace lens housing and control knob.

Projectors with Zoom Lens (Models 805 and 806)

Replace the lens by sliding into place with flat side of collar against projector. Push lens as far to the rear as possible and assemble focusing lever in place with lever tilted all the way to rear, resting against film path housing. Hook spring under projector hook and move lever to a vertical position (Fig. 22). Be sure lens moves smoothly back and forth. Replace lens housing, screw and control knob and test the projector. If you cannot focus closer than six feet, turn off projector, remove knob, screw and lens housing, loosen spring and focus lever and pull lens forward one groove. Reassemble.

CAUTION: Make certain control switch knob is in the OFF position when reassembling projector. Push knob ALL THE WAY IN.

(Model 807)

Replace lens by gently pulling out on the focus knob and sliding lens into place.

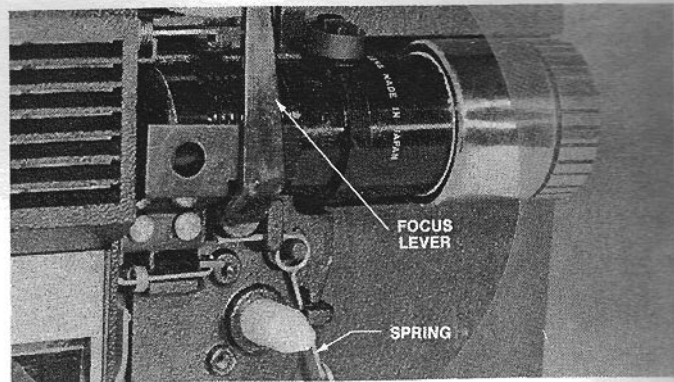

FIG. 22

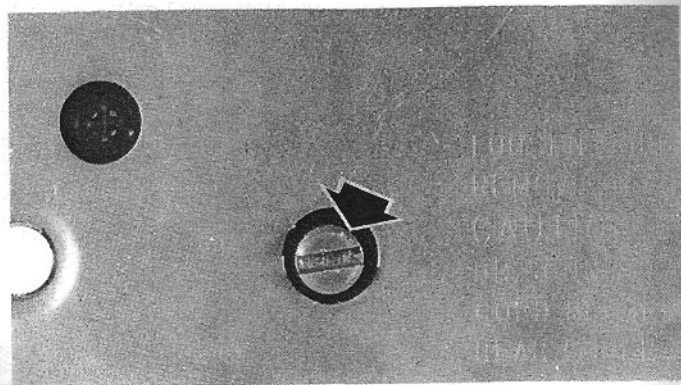

FIG. 23

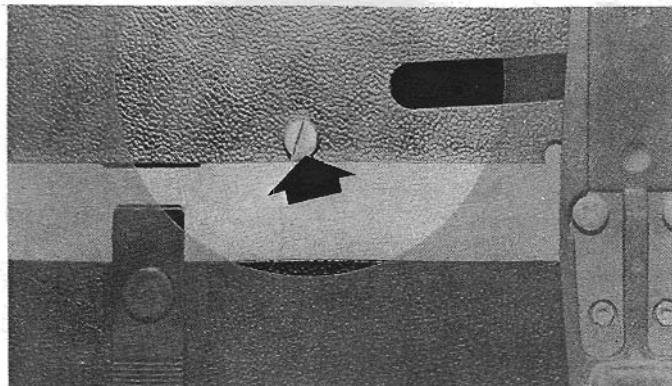

FIG. 24

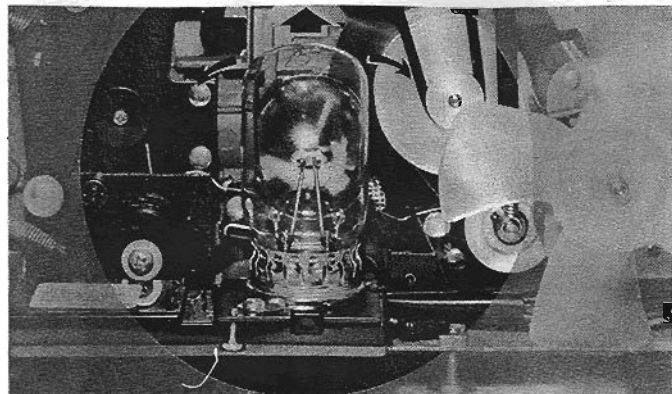

FIG. 25

3. REPLACING PROJECTION LAMP

Unplug power cord, loosen cover retaining screw on bottom of projector (Fig. 23 Model 807, Fig. 24 Models 804, 805 and 806) and lift off back cover to give access to the lamp. Be sure lamp is cool. Remove by pulling straight up—do not twist. If lamp is tight in the socket, rock it from side to side until it can be pulled straight up (Fig. 25). Replace lamp in socket and rotate until key on lamp base is aligned with keyway in receptacle. Push down firmly to seat. Use ASA Code DMD or DGB 80-Watt, 30 Volt Projection Lamp.

NOTE: Obtain replacement lamp from your WARDS store. If lamp is not available order direct from nearest WARDS service center listed on back cover of this book.

4. CLEANING THE MIRROR

The mirror is located behind the projection lamp and is accessible when the lamp is removed. Dust can be removed from the mirror with a small soft brush. Do not clean with lens tissue or other cleaners. Do not remove the mirror or touch it with fingers.

5. LUBRICATION

Your projector is lifetime lubricated by the manufacturer. No further lubrication is necessary.

**MONTGOMERY
WARD**

SERVICE CENTERS

- EAST COAST:** Berkey Repair Service
132 4th Avenue
New York, NY 10003
- SOUTHEAST:** Consumer Photo Service
Suite 340, Vantage Park
7094 Peachtree Industrial Blvd.
Norcross, GA 30071
- MID-WEST:** International Camera Corporation
844 West Adams Street
Chicago, IL 60607
- WEST COAST:** AAA Repair Service
16217 Kittridge Street
Van Nuys, CA 91406

**IF YOU WISH TO RESHIP THIS PROJECTOR
FOR ANY REASON, BE SURE TO REPACK
IN ITS ORIGINAL CARTON.**

SPECIFICATIONS

TYPE: 8mm automatic threading movie projector
FILM: Standard or Super 8, up to 400-ft. capacity
FILM THREADING: Automatic, reel to reel.

FEATURES:

- Forward only projection (Models 804 and 805)
- Still and Reverse projection (Models 806 and 807).
- Slow motion projection, 6 FPS (Models 805 and 806).
- Step motion projection, 2 and 6 FPS (Model 807).
- Fast Forward film advance (Models 806 and 807).
- Automatic rewinding (Model 807).
- Room light receptacle (Model 807).

PROJECTION LENS:

- 22mm f/1.6 (Model 804).
- 20-32mm f/1.5 zoom (Models 805 and 806).
- 20-32mm f/1.4 zoom (Model 807).

PROJECTION LAMP: DMD or DGB 80-Watt, 30 Volt.

POWER: 110-120 Volts, 60 Hz AC.