

# Film-Tech

The information contained in this Adobe Acrobat pdf file is provided at your own risk and good judgment.

These manuals are designed to facilitate the exchange of information related to cinema projection and film handling, with no warranties nor obligations from the authors, for qualified field service engineers.

If you are not a qualified technician, please make no adjustments to anything you may read about in these Adobe manual downloads.

[www.film-tech.com](http://www.film-tech.com)

BRENKERT BX-100

IB-24991



INSTALLATION INSTRUCTIONS  
and OPERATING MANUAL

# RCA-100

MOTION PICTURE PROJECTOR MECHANISM

Distributed by RCA Theatre Equipment Supply Dealers

Theatre Equipment

**RADIO CORPORATION OF AMERICA**

Engineering Products Department, Camden, N. J., U. S. A.

# TABLE OF CONTENTS

	<i>Page</i>
<b>Technical Summary</b> .....	4
<b>Description</b>	
General .....	5
Gear Train .....	5
Intermittent .....	7
Lubrication .....	8
Film Side .....	9
Framing .....	11
Lens Mount .....	11
Light Shutters .....	11
Changeovers .....	12
Screening Rooms .....	13
<b>Installation</b>	
Unpacking .....	13
List of Parts .....	13
Attaching to Soundhead .....	13
<b>Operation</b>	
Lubrication .....	17
Threading .....	18
Adjustments .....	19
Cleaning .....	19
<b>Maintenance</b>	
Housing Unit .....	20
Intermittent Unit .....	21
Intermittent Framing Unit .....	23
Lower Film Sprocket .....	23
Upper Film Sprocket .....	24
Light Shutters and Shutter Drive .....	25
Governor and Fan Unit .....	28
Main Drive Gear Unit .....	29
Oil Pump Unit .....	29
Shutter Compensator Unit .....	30
Lens Mount .....	31
Film Trap .....	31
Film Gate .....	33
Picture Changeover .....	33
Replacement Parts .....	35

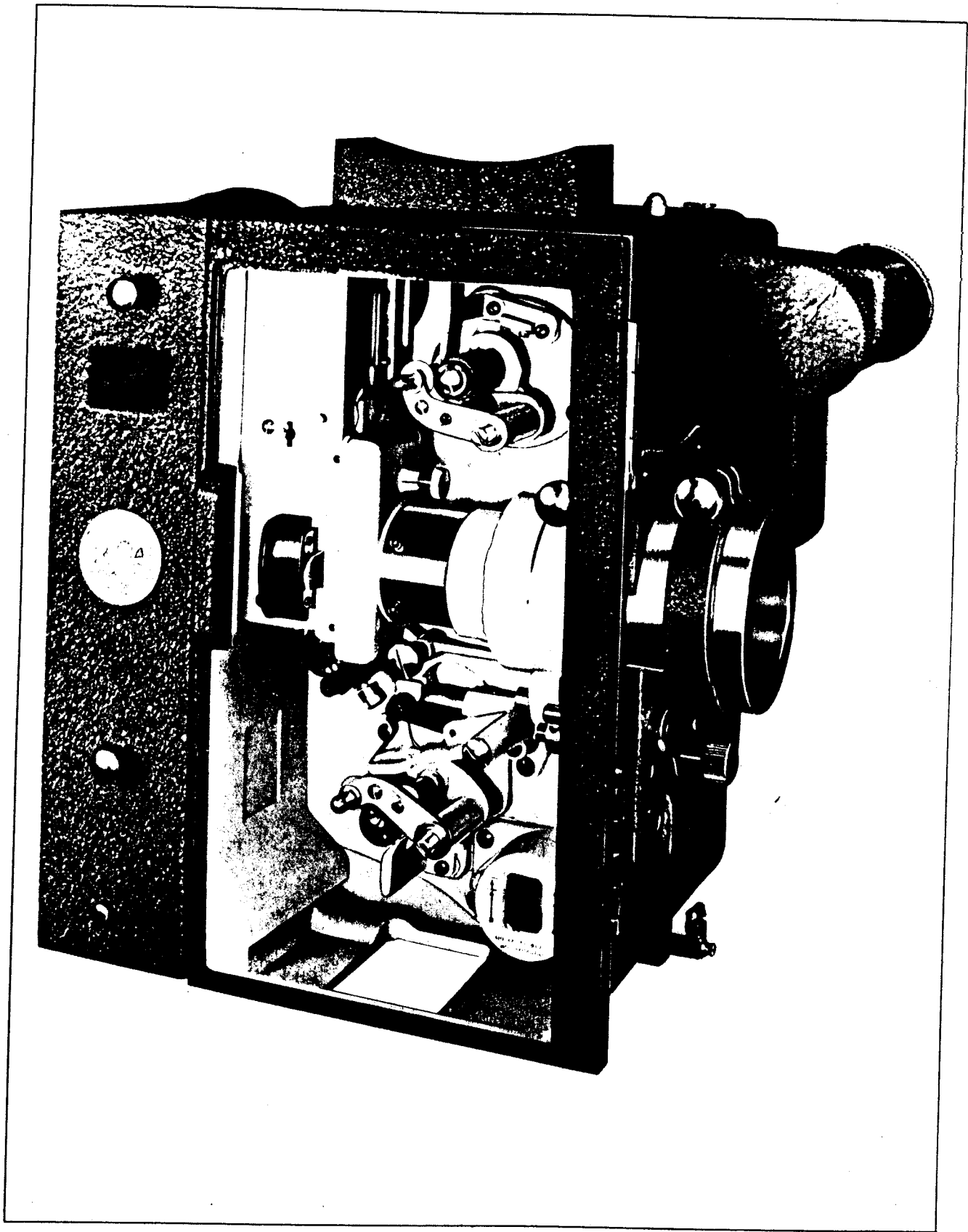

## TECHNICAL SUMMARY

<b>Overall Dimensions and Weights</b>	<b>Crated</b>	<b>Uncrated</b>
Length (inches) .....	25	16½
Width (inches) .....	17½	13
Height (inches) .....	26½	17½
Weight (pounds) .....	145	90

### **Electrical Requirements**

Electric changeover (*) (Sold as extra accessory) .....	110 volts, 60 cycles
Pilot lights .....	110 volts

### **Adaptability**

The RCA-100 can be used with all standard types of soundheads, arc lamps, pedestals and film magazines.

### **Projection Lens Accommodation**

All standard types and makes of projection lenses can be used with the RCA-100. The lens mount for the standard diameter projection lens is supplied unless lens mounts for the 4" diameter projection lenses are specified.

### **Projectors for Screening Rooms**

Projector mechanisms with three-bladed shutters and other modifications required for optimum results in screening rooms and film laboratories are available on special order.

---

(\*) Changeovers are also available on special order for operation on 110 volt DC, 110 volt 25 cycle, and 110 volt 50 cycle power supplies.

**APPROVED BY UNDERWRITERS LABORATORIES.**

## DESCRIPTION

The RCA-100 deluxe motion-picture projector mechanism is designed to meet the most exacting requirements for high quality projection in all types and sizes of theatres where 35mm motion-picture film is used.

Mechanical standards for adaptability already established in the motion-picture industry, have been incorporated in the design of this projector mechanism to make it compatible with all standard types of projector bases, soundheads, film magazines, and projection lenses without any field modifications.

A heavy one-piece metal casting, sturdily constructed and smartly styled, provides a housing and a main frame for the entire mechanism. This casting has been thoroughly and carefully heat treated so that it cannot warp out of shape. The sturdy non-warp main frame supports all of the working parts of the projector on accurately machined surfaces, assuring correct alignment of all shafts. All unpainted metal surfaces have been plated or chemically treated to protect them against rust and corrosion; all screws have been hardened and finished.

Unit construction is used throughout to facilitate easy, quick, and accurate servicing. All units are doweled to the main frame for correct alignment of all parts, thereby maintaining forever the original accuracy built into the mechanism. The accessibility for repair has been stressed beyond anything known in past practice, with the result that repairs can be made quickly and accurately by the projectionist, enabling him to maintain his mechanisms in peak operating condition at all times.

The film side of the projector mechanism is enclosed with a large glass door through which the projectionist can observe every nook and corner of the entire film compartment. Two lights, concealed so that they do not glare into the projectionist's eyes, illuminate evenly all parts of the film compartment. This aids in the accurate threading of the mechanism and in cleaning and inspecting all operating parts.

The interior of the film compartment has been finished in a soft light beige, attractive in appearance and making it easy to keep the film compartment neat and clean at all times. Plenty of space is provided between all operating parts in the film compartment for ease in threading quickly and accurately; cleaning and making operational adjustments can be accomplished in a minimum of time,

thereby allowing more time to the projectionist for the many other duties he must perform in the projection room.

Quick access to the shutter blades and rear of the film trap is accomplished by the removal of the rear panel on the film side which is held in place by two thumb screws. A colored glass is provided in this panel for viewing the light on the aperture.

A large oil gauge is located in the lower front corner of the main case, shielded against damage, yet in direct view of the projectionist each time he looks into the film compartment. The oil gauge is an integral part of the oil pump; large entrance and exit ports assure correct oil level indications.

The gear side of the mechanism is completely enclosed by a cover, held in place by three screws and quickly removable. An oil resistant neoprene gasket is attached to the rim of this cover making it absolutely dust tight as well as oil tight. A large heat treated glass in the cover permits viewing the entire gear train without removing the cover. All parts used in making up the gear train are of generous dimensions and high precision manufacture; the entire gear train is maintained clean and free from dirt and grit, and is lubricated by a shower of oil continuously so that wear is negligible even after many years of operation.

The design principles and operational features incorporated in the RCA-100 motion-picture projector mechanism resulted from a careful analysis of the requirements necessary for high quality projection over a long period of time, high efficiency of light transmission, ease of operation and servicing, and trouble-free performance. The text which follows describes in detail the main components making up the RCA-100 projector mechanism and describes some of its features. Complete information is also given on the procedure for installing, operating and servicing the mechanism.

### Gear Train

A correctly engineered gear train in a motion-picture projector mechanism is essential to high quality projection over a long period of time, smooth and quiet operation, dependability and low maintenance cost. Unless the gear train is correctly engineered and accurately manufactured, wear will soon take place and inferior projection and noisy operation will progressively increase after the projectors have been in use over a period of time.

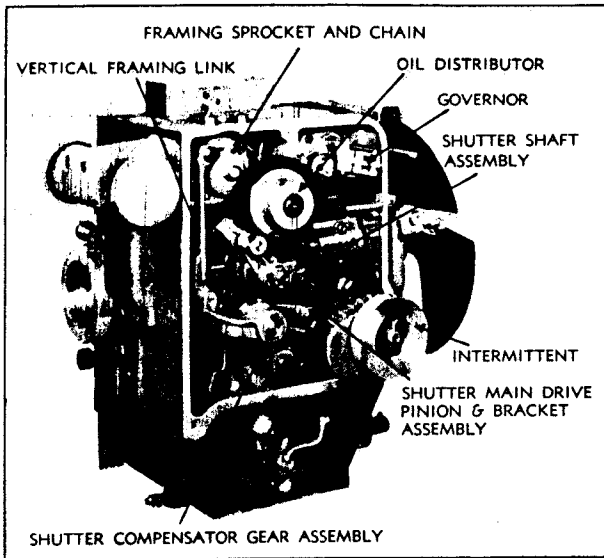

Figure 1—Gear Train with Main Assemblies Identified

The gear train in the RCA-100 projector mechanism has been designed to maintain the original high efficiency and perfection of performance for many years with a minimum of attention and low upkeep cost. Figures 1 and 2 show the gear side of the RCA-100 projector mechanism with parts and assemblies identified.

Helical gearing on parallel shafts is used throughout, except for the spiral bevel gears which drive the shutter shafts. Using this type of gearing, mating gears can be set up with negligible backlash and meshing teeth contact each other over the full width of the gear face. Negligible backlash is essential for smooth and quiet operation.

All gears are of large diameter with a  $\frac{3}{8}$ " wide gear face; the gear teeth are cut on an angle that will produce a minimum of lateral thrust. Large diameter gears result in greater radial accuracy and therefore smoother and quieter operation; a wide gear face provides a greater contact area between meshing teeth, which results in a longer life for the gears. Steel gears are mated with phenolic gears wherever necessary to increase the life of the gears and reduce gear noise to a very low level. Large diameter, high grade steel shafts and long bearings are used throughout to maintain the original accuracy of the gear alignment.

A low gear ratio is essential between the important drive assemblies in a projector mechanism for minimum wear and noise, and to prevent vibration traveling throughout the mechanism. A 2 to 1 gear ratio is maintained in the RCA-100 mechanism between the projector drive, the intermittent, and the shutter drive shafts.

The light-shutter-compensator gear assembly has

an important role in maintaining high quality projection in the RCA-100 mechanism. The purpose of this gear assembly is to enable framing the film at the picture aperture by swiveling the intermittent, while at the same time maintaining perfect timing between the shutters and the intermittent. Angular driven, or straight line sliding gears, which wear rapidly and cause noise and inferior projection, are not used in this assembly.

The shutter-compensator gear assembly is shown in figure 3. It is connected to the framing knob and the intermittent by a linkage system attached to bracket "A", and to the shutter drive shaft assembly by gear "E". When the framing knob is turned, the action is transmitted through the linkage system resulting in bracket "A" moving in an upward or downward direction (depending on which direction the framing handle was turned), and swiveling the intermittent movement in a corresponding direction.

When the position of bracket "A" is changed, the spline shaft "B" changes its position correspondingly in a lateral direction. Attached to the spline shaft "B" are spline nuts "C" and "D" upon which are mounted gears "E" and "F". These spline nuts are sleeves with multiple keyways cut into them in such a manner that the keyways in one spline nut meet those in the adjacent spline nut at an angle. The gear hubs are slotted to fit exactly into the keyways of its spline nut. When the spline shaft "B", therefore, is moved laterally, the spline nuts "C" and "D" are also moved laterally, causing gears "E" and "F" to change positions radially with respect to each other. The radial position of these gears is changed

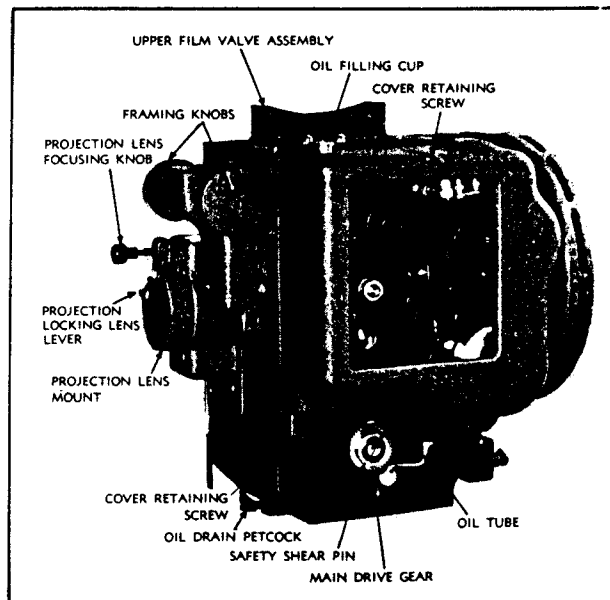

Figure 2—Gear Side of Projector with Main Assemblies Identified

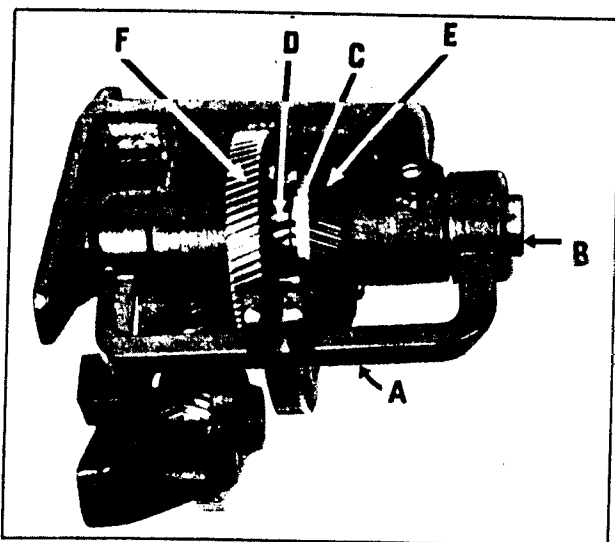

Figure 3—Shutter Compensator Gear Unit

exactly enough to keep the light shutters in perfect time with the intermittent after framing adjustments are made.

Since only the radial position of gears "E" and "F" is changed with respect to each other, they will mesh with identically the same teeth in their mating gears as before framing. With this type of shutter compensator it is not necessary to change the position of the framing knob periodically; the projector will run smoothly and quietly with the framing knob in any position; wear and backlash between gears is eliminated. The same perfect picture definition and high efficiency of light transmission obtained originally, is maintained throughout the life of the projector.

The light shutters are driven by two long, large diameter steel shafts, one rotating within the other. These shafts are held in perfect alignment by a heavy casting with three long bearings. Spiral bevel gears are used for driving the shutter shafts so as to obtain maximum tooth contact between mating gears. Since the shutters are not used as fans for cooling the aperture, and since the governor and no other parts are attached to the shutter shafts, the driving force required to turn the light shutters is very low, and wear on the shutter drive gears is negligible over a long period of time. The complete shutter drive shaft assembly can be removed quickly and easily for servicing, as shown in figure 4.

Automatic lubrication is provided continuously over the entire length of the shutter shaft assembly; openings in the bearings allow an abundance of filtered oil to flow continuously between the shafts and the bearing surfaces assuring complete lubrication, and at the same time keeping all parts of the shafts and bearing surfaces at a low temperature.

The governor unit is designed to work with equal accuracy at all projection angles. The design is

the loaded flyball type working in a horizontal plane. It operates against the weight of the fire shutter and associated linkage by means of a push rod. The governor unit is simple in design, sturdily constructed and continuously lubricated.

A mechanical fuse or shear pin located on the outside gear face at the bottom of the gear train, safeguards the entire gear train in the mechanism in case film breakage results in a film pile-up on any of the sprockets. In such an instance the pin will shear, disengaging the projector mechanism from the main drive gear. The pin can then be replaced easily in less than a minute.

### Intermittent Mechanism

The intermittent unit shown in figure 5 is used in the RCA-100 motion-picture projector mechanism; it is interchangeable with those used in all current RCA projectors. It is the most vital part of any projector mechanism and is commonly and correctly termed "the heart of the mechanism". The accuracy of engineering and design, and the precision of manufacture of this unit govern the original quality of projection, length of service, and upkeep cost. The importance of good engineering in its design, and the adherence to close tolerances in its manufacture are easily understood when one considers the function performed by this unit.

The intermittent must move the film a distance of one frame, or approximately  $\frac{3}{4}$  inch, in  $\frac{1}{96}$ th part of a second. This means that the film moved by the intermittent has an average speed of 360 feet per minute compared with a film speed of 90 feet per minute in other parts of the mechanism. However, the intermittent must start moving the film from complete rest and return it to a state of complete rest after it has been moved a distance of one frame. To accomplish this in  $\frac{1}{96}$ th part of a second, the film must reach a velocity of almost 900 feet per minute in approximately  $\frac{1}{200}$ th part of a second.

Each succeeding frame in the film moved by the intermittent must occupy exactly the same relative position in the film aperture. Any variation in the location of succeeding frames will show up as unsteady projection on the motion-picture screen. As an example, for each .001 inch variation in the location of succeeding frames in the film aperture with a projected picture 20 feet in width the picture will jump or weave approximately  $\frac{1}{4}$  inch. High quality projection over a long period of time therefore depends on a high degree of precision and accuracy in the manufacture of the parts making up this unit, and the design must be such that this accuracy is maintained.



The RCA intermittent shown in figure 5 is designed and manufactured so that the original accuracy is maintained over a period of many years. The star wheel, cam and cam pin are of large diameter with their shafts rotating in long bronze bearings; the use of large parts facilitates greater accuracy in manufacture and provides larger wearing surfaces, which in turn result in greater accuracy of operation and longer wear. The intermittent cam is driven by an external gear fitted to its mating gear with absolutely no backlash; the index pin on the cam is fitted with a hardened steel roller to prevent excessive wear and the development of flat spots. Each moving part in the intermittent is made of hardened steel, and held within microscopic tolerances.

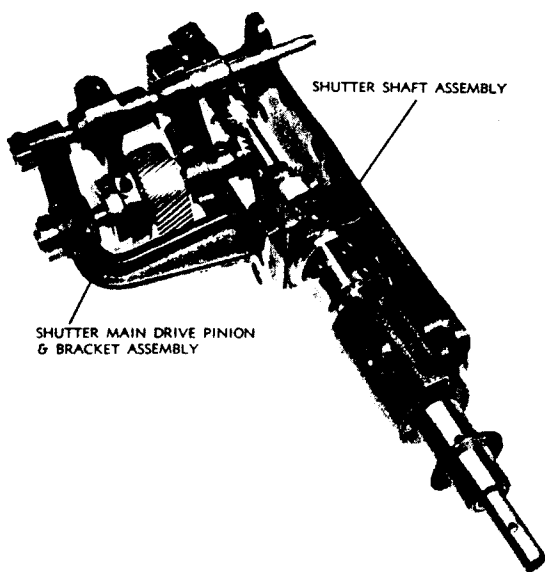

Figure 4—Shutter Main Drive and Shaft Assemblies

The star-wheel shaft in the RCA intermittent is  $6\frac{3}{8}$  inches long and  $7/16$  inch in diameter. It is supported by two long bronze bushings, one close to the star wheel and the other close to the film sprocket. The sprocket and star wheel, therefore, are both held rigidly and accurately in position, resulting in perfect film motion and quiet operation. Because of the large dimensions of this shaft and its two bronze bushings, wear is negligible and the original accuracy built into this unit is maintained over a long period of time.

An exclusive feature of this intermittent is the method used for attaching the intermittent sprocket. The sprocket can be removed for reversal or replacement in less than one minute; it is not necessary to remove the intermittent from the projector or dismantle it to replace the sprocket. This means quick, safe, and inexpensive sprocket replacement for

maintaining the high-quality projection standards built into this projector mechanism.

The complete intermittent mechanism can be removed and replaced as a unit easily, quickly, and safely in less time than is required for the running of an average reel of film.

#### Automatic Lubrication

A positive method of continuous lubrication is used in the RCA-100 projector mechanism to provide the right kind and the correct amount of lubrication at all places, thus assuring lasting high-quality performance, longer wearing of all parts and low upkeep cost. It is the same method of lubrication used so successfully in the DeLuxe BX-80 mechanism and which contributed so greatly in the tremendous acceptance of this projector mechanism by the motion-picture industry. Lubrication is continuous and completely automatic; no hand oiling is required. Fundamentally it is the same method of lubrication which has been used in automobiles for many years; today manufacturers of high-quality machine tools use this method of lubrication in their products wherever the highest precision of manufacture is required.

The lubrication in the RCA-100 projector mechanism is supplied from a reservoir in the base of the mechanism which holds approximately one pint of oil. A geared pump inside the housing delivers a continuous flow of filtered oil through a copper tube from the oil reservoir up to a rotary lubricator at the top of the gear train. This rotary lubricator is perforated at longitudinal spacings in such a manner that the various holes are in line with the plane of each gear and bearing in the gear train. Thus in operation oil is pumped from the reservoir to the rotary lubricator and then showered over all parts in the gear compartment, providing lubrication at the right places continuously.

With this method of lubrication, oil is circulated throughout the entire gear side of the projector mechanism several times a minute, and is filtered every time it passes through the intermittent unit and the oil pump. Not only is automatic lubrication provided continuously, but the flow of oil over the entire gear train maintains all parts at nearly the same low temperature. The heat generated in the intermittent is carried away by the circulating oil instead of remaining confined in the intermittent case. This automatic lubricating system thus also acts as an overall cooling system in distributing any local heat in the gear train throughout the whole mechanism; the overall temperature is thus kept at a very low value.

This method of lubrication is far superior to conventional manual methods such as the hand-oiled

system, or the pressure system fed from a common point, illustrated in figure 6. Using either of the latter two methods, oil is forced into the oil hole and is distributed over the surface of the bearing by the groove in the shaft. The groove, however, does not usually extend over the entire length of the bearing, otherwise the oil would soon flow from the ends of the bearings and the bearing would then have insufficient oil for safe lubrication. The shafts, therefore, are usually grooved up to within a short distance from each end of its bearing in an effort to keep oil inside the bearing for as long a time as possible. As a result, the ends of the bearings usually do not receive sufficient lubrication and soon start to wear rapidly. As soon as this wear occurs, oil flows readily from the ends of the bearings into the film compartment where it can become deposited on the film and cause inferior projection, or drop into the soundhead where it will eventually result in inferior sound. With the hand oiled or one-shot pressure method of lubrication, even when the projector mechanism is new, the leakage of oil from the ends of the bearings is exactly equal to the amount of oil forced into each oil hole every time the mechanism is oiled; eventually every bit of this oil will find its way into the film compartment, the soundhead, or deposited in the base of the projector mechanism.

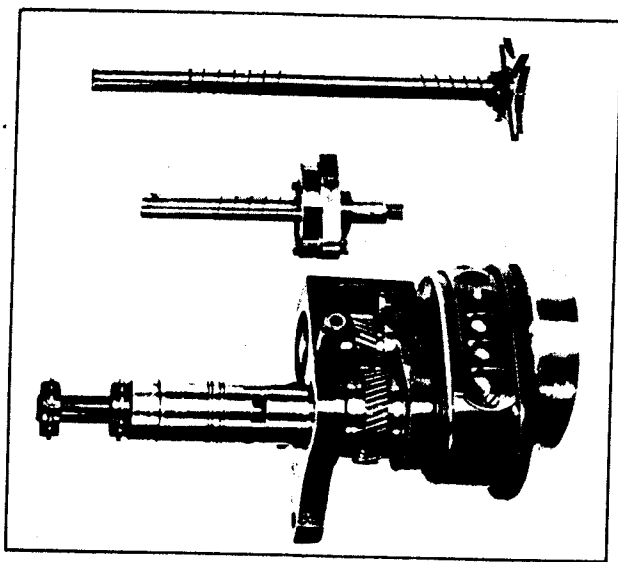

Figure 5—Intermittent Unit with Star Wheel and Cam Assemblies

All shafts and bearings in the RCA-100 projector mechanism are designed so that they are lubricated continuously over their entire length without any oil leaking from the gear compartment, as shown in figure 7. The oil which is showered throughout the gear compartment by the rotary lubricator flows

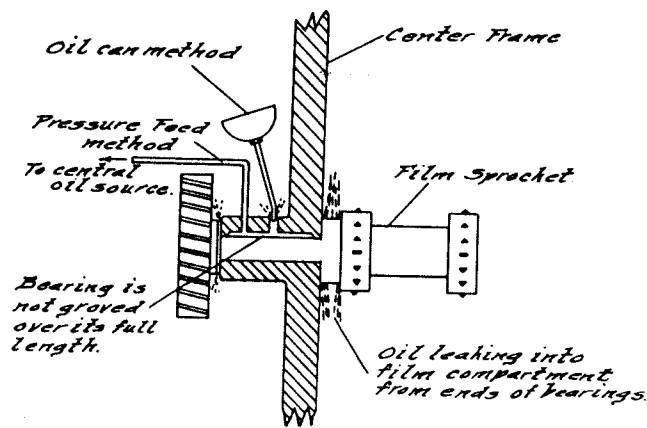

Figure 6—Manual Oiling System

over every part, and into all the oil holes provided in each bearing.

The shaft in each bearing is grooved over its entire length so that oil can flow continuously through these grooves and out at each end of the bearing, thereby providing at all times an abundance of oil to wash, cool, and lubricate correctly, the entire length of the bearing. Carefully designed oil baffles and oil slingers on the shafts which protrude from the gear compartment prevent the oil which flows from the ends of the bearings, from getting outside of the gear compartment or into the film side of the mechanism. This method of lubrication is reliable because it is automatic and starts instantly when the projector mechanism is started; it is best for a motion-picture projector mechanism because it is the most dependable; it is economical because wear on all moving parts is practically eliminated, so that the original accuracy built into the projector mechanism, and high quality projection is maintained over a longer period of time at low upkeep cost.

#### The Film Side of the Mechanism

The film side of the RCA-100 is shown in figure 8. The design and location of all components in the film compartment of the RCA-100 projector mechanism is such that plenty of space is provided between all units to facilitate rapid and accurate threading of the film, ease in making operational adjustments, and ease in keeping the film compartment neat and clean. All parts can be removed as complete assemblies for ease of servicing.

Oiling is not required on the film side of the mechanism because of the complete and automatic method of lubrication used as described above. Surplus oil, therefore, cannot get on the film or the projection lens or drop into the soundhead, resulting in inferior projection or poor sound. Considerable

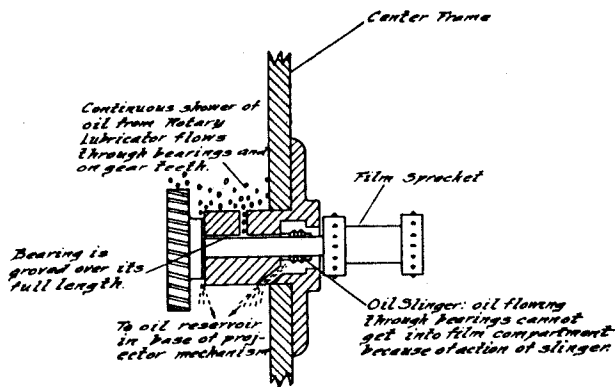

Figure 7—Automatic Oiling System

time is also saved for the projectionist because without surplus oil in the projector mechanism and soundhead, less time is required to keep the mechanism neat and clean.

All sprockets are hardened and then precision ground for smooth, quiet, and accurate running of all types of film. The sprockets are identical with those used in all current RCA projector mechanisms.

The intermittent sprocket as well as the upper and lower feed sprockets, can be removed and replaced in less than one minute by simply removing one screw and pulling the sprocket off of its shaft. If desired, the sprocket may be reversed to obtain double wear. The cost and the time required to replace sprockets is negligible; in addition, there is no danger of damaging or disrupting the adjustment of the various parts in the intermittent when replacing the sprocket, such as exists when it is necessary to disassemble the intermittent to replace the sprocket. Because of the ease, simplicity, and low cost to replace sprockets, there will be less hesitancy on the part of the projectionist and theatre owner to replace or reverse the sprockets before excessive wear takes place, thereby maintaining the original high quality of projection.

Double nylon pad rollers are used on both the upper- and lower-feed sprockets. These pad rollers are held in accurate alignment with the sprocket by a sturdily constructed bracket which provides a bearing surface at each end of the pad roller. These pad rollers may be removed easily for cleaning or the complete pad roller assembly can be taken out as a unit simply by the removal of one screw. These nylon rollers do not require oil, thereby eliminating the possibility of oil getting on the film from this point. The film strippers are of a new and special design so as to prevent the film from wrapping around the sprocket in the event of film breakage.

The film trap is constructed on a heavy one-piece iron casting specially heat-treated to prevent warp-

ing. It can be removed easily between reels for cleaning and inspection; replacement can be made quickly and accurately, as the entire unit is doweled to the main frame to insure perfect alignment with the intermittent sprocket and the optical axis. The film trap is completely interchangeable with replacement units. The film is guided the full length of the film trap to prevent film side sway. The film tracks and the film guides are made of highly polished steel, hardened and precision ground, and are interchangeable from one side of the trap to the other so that when they become worn, they can be interchanged and the opposite sides of them used, thereby obtaining double wear.

Standard removable film apertures .825 x .600 are available with either square or with round corners. In addition, removable apertures .800 x .600 are also available for use where a high-projection angle exists, so that the sides of the aperture can be filed to compensate for keystone. The picture aperture can be instantly removed for cleaning even while the picture is being projected. The entire film trap is cooled by the action of a rotary fan directly above the film trap drawing air up from the bottom of the projector through the film trap and past the heat baffle and picture aperture, exhausting it from the top of the main case. With this method of cooling it is not necessary to use vanes on the shutters which create a draft in the lamphouse and causes unsteady illumination. The use of vanes on the shutters also places an extra load on the shutter drive gears which cause them to wear more rapidly, resulting in noisy operation and inferior projection. Adequate cooling is provided so that even when high-powered arc lamps are used, the picture aperture will remain well within a safe operating temperature.

A framing aperture is built into the film trap exactly five picture frames above the picture aperture. The framing aperture is brightly illuminated by a framing lamp and is clearly visible even with the film gate in its closed position. This framing aperture facilitates accurate and rapid threading of the film.

Both the automatic fire shutter and the picture changeover dowser operate outside the film trap casting. The automatic fire shutter is operated through a linkage system by a push rod connected to the governor. The picture changeover dowser is operated by an electric changeover mechanism attached to the top of the main case.

The film gate is mounted on an accurately ground sub-base and operates on two large diameter guide rods which hold it in accurate alignment with the aperture plate at all times. The gate is held rigidly and accurately to its mounting surface by means of

two locating pins and a knurled thumb screw so that it can be removed and replaced quickly and accurately for cleaning and inspection. The gate in its open position allows plenty of room for threading the film in the mechanism, and for inspecting the film trap shoes and gate pressure pads.

In its closed position the gate is positively locked by a unique toggle lock and spring, thereby insuring against accidental openings during operation, and automatically taking out all play between the gate and the aperture plate.

Three sets of hardened, polished steel pressure pads are provided on the gate to insure steady motion of the film through the gate, and to hold the film firmly and accurately against the aperture plate when the picture is being projected. The tension on all of the film pressure pads is obtained through oil-tempered springs which are adjusted simultaneously by a single adjusting screw. The tension on the pads is applied centrally and distributed equally along both sides of the film so that the film travel is smooth and its positioning is accurately held.

The intermittent sprocket pressure pad is located on the lower part of the film gate. It is designed to hold the film firmly against the periphery of the sprocket. An adjustable thumb nut is provided on this pressure pad so that the tension can be adjusted for quietest running of film.

### Framing

The framing knobs on the RCA-100 mechanism are located at the front of the projector directly above the lens mount where they are easily accessible from both sides of the projector mechanism, and close to the observation port so that framing can be done accurately and quickly.

Framing the picture at the aperture is accomplished by swiveling the intermittent so that the sprocket is always in the same relative position with respect to the picture aperture regardless of the position of the framing knob. This is the most desirable method to use for framing because the film is always supported in the film trap directly to the sprocket, eliminating any possibility of film flutter and unsteady projection. One other advantage of this method of framing is that wear on the sprocket teeth is more uniform than if the framing were accomplished by moving the intermittent sprocket up and down with respect to the film trap. When the latter method is used for framing, the same four pair of sprocket teeth (90° apart) always do the maximum amount of work in pulling the film down, thereby resulting in rapid wear and excessive hooking of these teeth. The framing method used in the RCA-100 projector results in

longer life for the intermittent sprocket because all sprocket teeth wear uniformly.

### Lens Mount and Focusing Device

The RCA-100 is furnished with a standard size lens mount for projection lenses up to 2<sup>5</sup>/<sub>32</sub>" diameter. A large lens mount for the 4" diameter high speed, long focal length lenses is available and will be furnished with the projector mechanisms when requested in place of the standard type.

Both of these lens mounts are unit constructed and can be removed easily for servicing and inspection. They are designed to hold the projection lens firmly and in accurate optical alignment. A focusing knob on the front of the lens mount is easily accessible for adjustment from both sides of the projector mechanism. Absolutely no back lash exists in this adjusting screw so that once the projection lens is focused, the adjustment will be held accurately.

### Double Rear Shutters

The RCA-100 mechanism uses two rear disc-type light shutters rotating in opposite directions within <sup>3</sup>/<sub>8</sub>" of the same vertical plane. It is more desirable to have both shutters at the rear of the mechanism between the light source and the picture aperture, as in the RCA-100, because the heat from the light beam is on the picture aperture less time than if one front and one rear shutter were used. This is much more important now than ever before because of the powerful light sources being used at many of the large in-door theatres, and drive-in theatres. Another advantage in having both shutters at the rear of the mechanism is that it is easier to remove the projection lens for cleaning, than if it were obstructed by a front shutter and shutter guard. Thus, having both light shutters at the rear makes it easier for the projectionist to maintain high quality projection. The light shutters on the RCA-100 are not equipped with vanes for cooling the film aperture by pumping air against it. Thus, operation of the arc lamp is not disturbed by air drafts from the projector, making it unnecessary to place a glass baffle between the light source and the light shutters, which would reduce light transmission to the screen by approximately 8% in most cases.

Adjustments for increasing the width of the shutter blades on the RCA-100 mechanism are not necessary as the design of the gear train in the RCA-100 mechanism is such that wear, even after many years of operation, is negligible; adjustable light shutters, therefore, are not necessary.

It is extremely easy to "time" the shutters on the RCA-100 mechanism. Special aligning tools are not

required and it is not necessary to remove the projection lens when making this adjustment. Minor changes in the adjustment of the shutters can be made easily and quickly when the mechanism is operating by a micrometer adjusting screw.

Both shutters on the RCA-100 mechanism can be easily and quickly removed as complete units, and replaced without disturbing the timing.

#### Electric Changeover

The MI-14312 changeover mechanism was designed and styled especially for use with the RCA

projector. This changeover mechanism consists of a large one-piece casting in which are assembled the heavy duty coils of the solenoid. The light dower which is located behind the film trap main casting is operated by the changeover through a linkage system. The changeover coils are designed so that quick and positive operation will result when the changeovers are connected to either a 110 volt AC or DC power source. A six-foot length of three-wire BX-cable is provided with each changeover so that it can be connected to a junction box in the projection base. The complete changeover

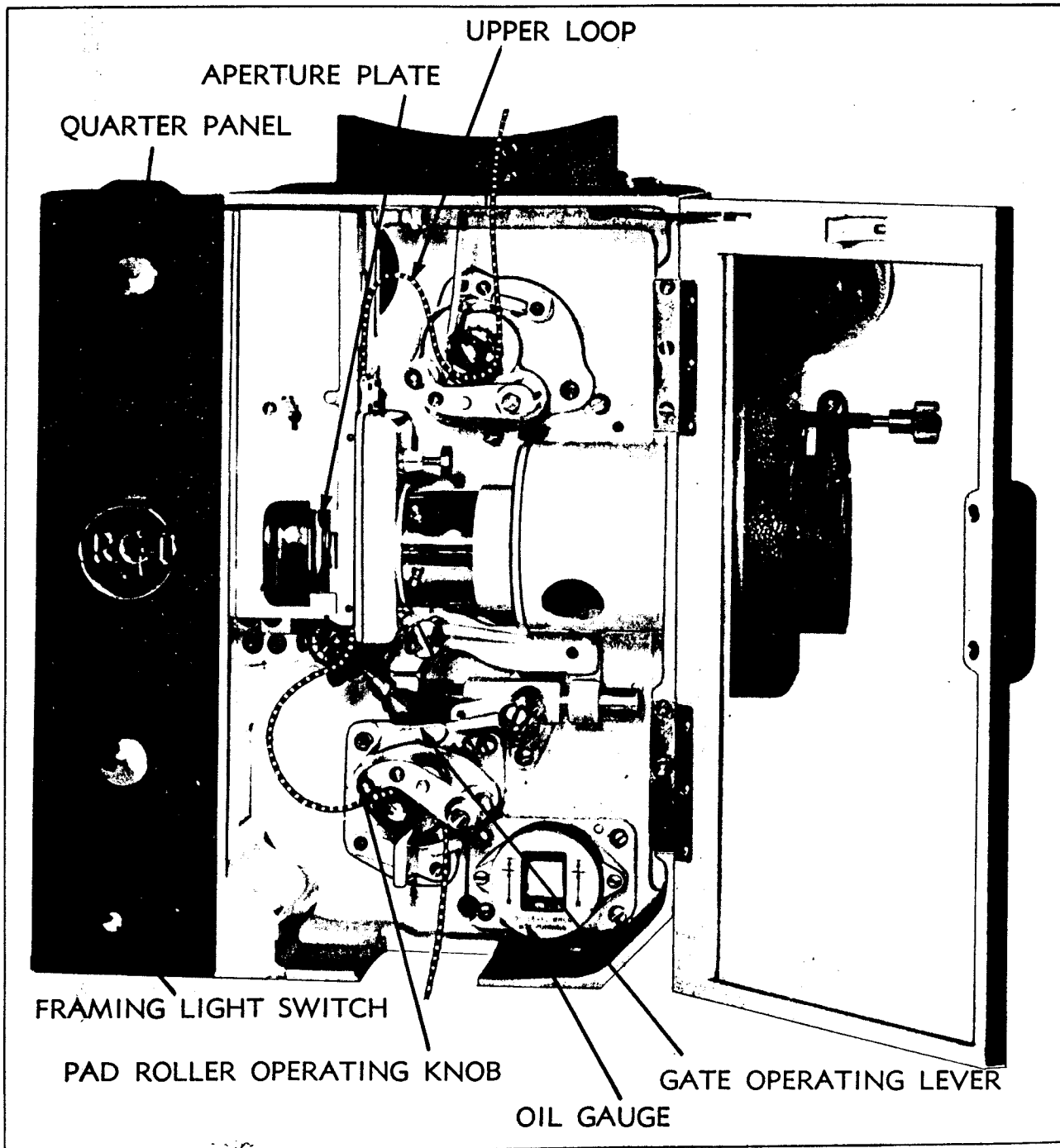

Figure 8—Film Compartment Showing Assemblies and Film Path

mechanism is attached to the top of the projector main case directly behind the upper magazine. It is held in place by two screws and is easily removed for servicing.

The MI-14313 picture changeover may also be used with the RCA-100 mechanism.

### Projectors for Film Preview and Screening Rooms

The RCA-100 projector is also available with special modifications to meet requirements when it is used in motion-picture screening rooms and film laboratories.

The size of the picture projected in screening rooms and film laboratories is usually relatively small and when regular suprex types of arc lamps are used with standard projector mechanisms the intensity of the light on the screen will be in excess of that required. The RCA-100 projectors furnished for this use are, therefore, equipped with three-bladed shutters so that the actual light transmitted to the screen is reduced by approximately 50% from that which would be transmitted if two-bladed shutters were used. This is the most desirable method to use for reducing the intensity of light on the screen because there is less heat on the film, and complete absence of shutter flicker within the recommended range of screen light intensity.

## INSTALLATION

The RCA-100 projector mechanism is packed in a sturdily built box and enclosed in an inner carton of corrugated fibre board, adequately braced and padded for protection. Excelsior and other loose packing material is not used. All projector mechanisms are carefully inspected, tested, and adjusted before leaving the factory. Unnecessary rough handling must be avoided when unpacking so as to avoid damage to any of its parts.

### Unpacking

Caution must be used in handling the projector during the unpacking operation so as not to damage the mechanism or lose any of its accessories. The unpacking should be done as closely as possible to where the installation is to be made to prevent excessive handling after the projector mechanism has been removed from its packing case. To remove the projector from its packing case, the procedure outlined below should be followed:—

1. Open the top lid of the shipping container.
2. Remove the corrugated fibre board bracing.
3. Lay the shipping container on one of its long sides and pull out the complete corrugated carton.

4. Set the carton in an upright position and open the top.
5. Remove the box of accessories found inside the carton; set this box in a safe place until ready to assemble the mechanism on the soundhead.
6. Lay the projector carton on one of its long sides.
7. Open the bottom of the carton and turn the flaps back against the sides.
8. Turn the complete carton on one of its adjacent sides or ends; make sure that all bottom flaps are turned out.
9. Set the carton in its upright position and then pull it from around the projector.
10. Remove the wooden boards from the top and the bottom of the projector.

### Projector Parts and Accessories

The following items are shipped with each projector mechanism and will be found packed in the corrugated accessories carton.

- 1—Pint projector oil (stock No. X-2437).
- 1—Upper film valve complete with mounting screws.
- 1—Flexible metal cable for framing light.
- 2—Upper magazine screws and washers.
- 2—Anti-short bushings.
- 2—Projector-drive X-1729 shear pins.
- 1—Instruction book. (One furnished with each pair of projectors.)
- 1—Picture changeover (when ordered).
- 1—Changeover footswitch (when ordered).

### Attaching the Projector to the Soundhead

Before setting the projector on the soundhead determine if the location of the oil drain petcock is correct. The petcock must be in the hole provided in the base at the front of the projector for standard theatre operation where a down tilt exists, and at the rear of the projector for drive-in theatre operations where an up tilt exists. Refer to the maintenance section, page 20, covering instructions for removing and changing the location of the petcock.

Three mounting holes are provided in the bottom of the projector mechanism main frame for attaching it to the soundhead or projector mounting plate. The two mounting holes under the gear side of the mechanism are blind-threaded holes  $\frac{1}{2}$  inch deep. The third mounting hole is located directly under the oil pump on the film side of the projector. All three mounting holes are threaded for a standard  $\frac{3}{8}$ -16 screw.

When the projector mechanism is to be attached to early types of soundheads it may not be possible to use the third mounting hole in the base of the projector. Clamping brackets are available for attaching the projector to the film side of these types of soundheads, and can be obtained at all RCA Theatre Equipment Supply dealers. The projector must always be attached to the soundhead at three points to insure absolute rigidity and freedom from vibration. Modern types of soundheads such as the RCA MI-9030 and MI-9050 are provided with projector mounting plates complete with the attaching screws.

Projector drive gears are available for driving the RCA-100 projector mechanism from all standard types of soundheads. Table No. 1 shows the type of project main drive gear and other accessories required for operation with several of the more common types of soundheads.

When the projector is to be attached to a soundhead equipped with a projector mounting plate, attach the plate securely to the base of the projector using the screws provided with the mounting plate; set the projector on the soundhead and attach the mounting plate to it with the screws provided but do not tighten them until after the main drive gear has been adjusted. Attach the projector drive gear assembly and tighten the P-1010 screw located at the rear of the projector against the flat on the shaft, allowing approximately .005 inch end thrust between the projector main drive gear and the projector main case. Move the projector mechanism forward or backward by means of the eccentric screw in the back of the projector mounting plate until the projector drive gear is meshed with the teeth of its mating soundhead gear, with .003 inch backlash between the gear teeth around the entire periphery of the gear. When this condition has been attained tighten the four Allen screws attaching the projector mounting plate to the soundhead and then check the backlash in the projector drive gear again to make sure that it did not change when the mounting plate screws were tightened. Accurate gear and sprocket alignment is taken care of automatically when the projector mechanism is attached to a modern soundhead with a projector mounting plate.

To attach the projector mechanism directly to a soundhead which does not have a projector mounting plate, care must be taken to make sure that the projector is set on the soundhead so that the sprockets in the soundhead and projector mechanism are in exactly the same vertical plane. If these units are not aligned accurately the film may not register correctly on the sprocket teeth,

resulting in film noise and possibly film damage. Care must also be taken to make sure that the projector main drive gear is meshed correctly with the gear on the soundhead with approximately .003 inch backlash between meshing teeth. In some cases it may be necessary to use shims between the projector mechanism and the top of the soundhead to attain proper backlash between the projector drive gear and the soundhead gear. Whenever shims are used they should be made from standard brass shim stock and placed as closely as possible to the projector mounting screws, extending from the gear side edge of the projector mechanism base to the film side; the shims must be placed in front of the front mounting screw, and behind the rear mounting screw.

It is essential that the mounting screws for attaching the projector mechanism to the soundhead do not protrude more than  $\frac{1}{2}$  inch from the top of the soundhead casting. Longer screws *MUST NOT* be used as they will "bottom" in the mounting holes in the base of the projector mechanism and prevent it from being pulled tightly and rigidly against the soundhead; the bosses which support these threads may also be damaged.

Before attaching the upper magazine to the projector check the P-1013 screws in the X-1016 magazine sub plate to make sure that it is screwed tightly to the projector. Two  $\frac{3}{8}$ -16 x  $\frac{3}{4}$ -inch filister head screws are supplied with the projector for attaching the upper magazine. These screws will be found in a cloth bag packed in the corrugated carton which accompanied the projector mechanism. Do not use a screw which extends beyond the magazine mounting bracket more than  $\frac{5}{16}$  inch, or the screw will "bottom" on the top of the projector mechanism and prevent the magazine from being drawn down tightly and rigidly. If it is found that the mounting screws protrude too far through the holes in the magazine bracket, the flat washers supplied with these screws should be used between the head of the screw and the magazine mounting bracket.

When electric changeovers are ordered with the projector mechanisms, they will be found packed in the accessory carton. Each changeover is complete with three six-foot lengths of wire leads in flexible metallic cable, long enough to reach a junction box located inside the projector base.

The MI-14312 changeover is attached to the top of the projector housing directly behind the upper film magazine with the two P-1008 screws provided with the changeover. Make sure that the X-4200 piston arm fork engages with the X-2005 lever pin which actuates the changeover shutter. Operate the

**Table 1.—Parts and Accessories Required for Installing Brenkert Projectors on Soundheads Originally Modified for Use With Other Makes of Projector Mechanisms.**

Soundhead	Simplex E-7 Super Simplex Std. Simplex	Motio AA	Motio K	Motio H-U	Century	Powers	Kaplan Superior Wenzel
RCA—PS-22A	B-2741S	B-2741S	B-2741S	B-2741S	B-2741S		B-2741S
RCA—PS-24	B-3741SM	B-3741SM	B-3741SM		B-3741SM		B-3741SM
RCA—PS-26				B-3741SM 1-27470			
RCA—MI-1040/1050	MI-9129A 1-X-4401	MI-9129A 1-X-4401	MI-9129A 1-X-4401	MI-9129A 1-X-4401	MI-9129A 1-X-4401	B-5741P	MI-9129A 1-X-4401
RCA—MI-9001	MI-9129A 1-X-4401	MI-9129A 1-X-4401	MI-9129A 1-X-4401		MI-9129A 1-X-4401	MI-9129A 1-26604	MI-9129A 1-X-4401
RCA—MI-9030	MI-9129A (See Note 3)	MI-9129A (See Note 3)	MI-9174 MI-9129A	MI-9161A MI-9129A	MI-9129A (See Note 3)	MI-9161A MI-9129A	MI-9129A (See Note 3)
RCA—MI-9050	MI-9129A (See Note 3)	MI-9129A (See Note 3)	MI-9174 MI-9129A	MI-9174 MI-9129A 1-27926	MI-9129A (See Note 3)		MI-9129A (See Note 3)
WE—Universal Base	1-29369	1-29369	1-29369	(See Note 4)	1-29369	(See Note 4)	1-29369
WE—206A Repr.	1-29370 1-X-4406	1-29370 1-X-4406	1-29370 1-X-4406		1-29370 1-X-4406		1-29370 1-X-4406
WE—208A Repr.	1-29371 1-X-4406	1-29371 1-X-4406	1-29371 1-X-4406		1-29371 1-X-4406		1-29371 1-X-4406
WE—209/211 Repr.	1-X-4400	1-X-4400	1-X-4400		1-X-4400		1-X-4400
WE—TA-7400 Repr.	(See Note 1)	(See Note 1)	(See Note 1)		(See Note 1)		(See Note 1)
Motio—7500 Repr.	(See Note 1)	(See Note 1)	(See Note 1)		(See Note 1)		(See Note 1)
Motio—MK	(See Note 1-2)	(See Note 1-2)	(See Note 1-2)		(See Note 1-2)		(See Note 1-2)
Century—Std. & DeLuxe	(See Note 1)	(See Note 1)	(See Note 1)		(See Note 1)		(See Note 1)
Simplex Four Star	MI-9129A (See Note 5)	MI-9129A (See Note 5)	MI-9129A (See Note 5)		MI-9129A (See Note 5)		MI-9129A (See Note 5)
Ballantyne	(See Note 6)	(See Note 6)	(See Note 6)		(See Note 6)	(See Note 7)	(See Note 6)

**Notes:**

- The existing 17-tooth spiral pinion gear may be used by relieving the hub to the depth of the gear teeth a distance of  $1\frac{1}{16}$  inches from the gear face. In many cases it will be found that the existing pinion has already been modified.
- A take-up pulley is not provided in the Motiograph MK soundhead. The hub of the soundhead flywheel will have to be grooved for a  $\frac{3}{8}$ -inch diameter leather belt and new X-2439 shafts and X-2440 bushings ordered from the RCA Theatre Equipment Supply Dealer.
- The existing projector mounting plate does not have a hole for the third mounting screw. This hole can be drilled on the job or a new MI-9174 mounting plate can be obtained from the RCA Theatre Equipment Supply Dealer.
- The following list of parts are required and can be obtained from the RCA Theatre Equipment Supply Dealer:
 

1—WE adapter plate (700A)	29775	1—Steel pinion	29369
1—Helical gear (P-220755)	29533	1—WE drive (712)	29524
- Replace the textolite gear on the MI-9129A with the rubber composition gear removed from the four-star main drive gear assembly.
- The existing projector drive gear may be used without any change.
- Obtain following parts from the RCA Theatre Equipment Supply Dealer:
 

1—RSM-64 Projector Drive Gear	1—RSM-68 Shaft Oiler Tube
1—RSM-65 Projector Drive Pinion	1—RSM-74 Gear Guard
1—RSM-66 Drive Attach. Shaft	1—RSM Motor Support Casting
1—RSM-67 Shaft Oiler Washer	



piston manually to make sure that all parts of the linkage and the shutter operates freely and without binding and then tighten the two P-1008 mounting screws. Refer to the maintenance and replacement parts section, page 33, for the location of parts and instructions on adjusting the changeover unit.

The MI-14313 changeover is attached to the projector and adjusted by following the procedure outlined below (See parts diagram 15A):—

1. Remove the changeover dowser from the end of the flexible shaft with the No. 6 Allen wrench provided with the changeover.
2. Attach the changeover mechanism to the BX-19 mounting bracket with the two screws and washers provided, but leave them loose enough so that the changeover mechanism can be moved on the bracket easily.
3. Insert the flexible shaft guide tube through the opening at the top of the projector main case and position the changeover assembly so that the holes in the mounting bracket are directly over the mounting holes in the top of the projector main case.
4. Attach the mounting bracket to the main case with the 1/4-20 x 5/8 round head screws and flat washers supplied with the changeover.
5. Tighten the two screws attaching the changeover mechanism to its mounting bracket.
6. Slide the light dowser into the rear chute in the film trap with the attaching boss toward the rear of the projector mechanism.
7. Insert the flexible steel shaft into the hole at the top of the attaching boss and adjust the shutter on the shaft so that when the changeover is in its open position, the aperture is not obstructed by the shutter, and when in its closed position, the shutter completely covers the aperture.
8. Tighten the No. 6 Allen set screw in the boss firmly against the flexible shaft.
9. Tighten the adjusting screw on the top of the changeover until the shutter will not open when the footswitch is operated. Then loosen the adjusting screw slowly so that the shutter will open when the footswitch is operated. Do not loosen the screw enough so that the shutter opens with such force that it hits the top of the film trap casting, rebounds and partially closes the aperture. Figures 11 and 12 show the wiring and connections to the changeover units for two- and three-projector operation.

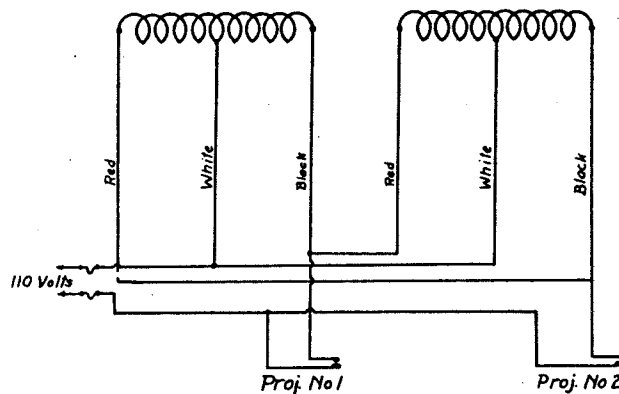

Figure 9—Wiring Diagram of MI-14312 Picture Changeover for Two Projector Operation

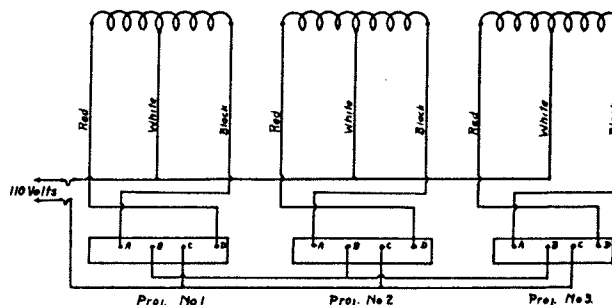

Figure 10—Wiring Diagram of MI-14312 Picture Changeover for Three Projector Operation

A piece of flexible metallic cable is packed in the accessory carton and is to be used for covering the two wire leads to the framing light junction box assembly. Care should be taken when covering the wires with the cable to prevent damage to the insulation. The two red anti-short bushings provided in the cloth bag packed in the accessory carton should be used, one at each end of the cable. Connect the two wire leads to a 110 volt power source.

The location of the picture aperture conforms with accepted and established standards. Standard arc lamps, therefore, can be mounted on the projector base and the proper working distance obtained without the necessity of any modifications. Care should be taken, however, to make sure that a clearance of at least 1/16 inch exists between the shutter guard and the end of the lamphouse cone. Also make sure that the optical axis of the arc lamp and projector mechanism are in perfect coaxial alignment by using the RCA #164835 aligning tool; this aligning tool is available at all RCA Theatre Equipment Supply dealer stores. When the projector and lamphouse are in correct alignment, tighten the screws attaching both of these units securely to the soundhead and projector base

respectively so that even though a very steep projection angle exists there will be no danger of either unit moving out of alignment.

All of the oil was thoroughly drained from each projector mechanism before it was packed for shipment; the shafts and bearings in the gear train and intermittent therefore may be dry and completely free of lubricating oil when the projector mechanism is received at the theatre for installation. It is important, therefore, before running the projector to apply RCA projector oil generously to all parts of the gear train and intermittent. This can be done using a clean Plews oil can, or any pressure type of oil can, filled with RCA projector oil, a supply of which will be found in the projector accessory carton. This oil is sealed in a can to prevent the possibility of foreign matter getting into it; the seal should be either punched or pried out of the can. The best method to use in applying oil to the gear train is to remove the gear cover so that all parts of the gear train are exposed and easily accessible. If a Plews oil can with a flexible nozzle can be obtained it will simply be necessary to insert the nozzle of the oil can in the large oil cup at the top of the gear cover and direct the oil to all parts of the gear train. Turn the projector over manually several times to make sure that the oil reaches all parts of the shafts and bushings. After the oil has been applied to all parts of the gear train and intermittent, pour enough additional oil into the gear side of the mechanism until the oil level, as shown in the indicator on the oil pump in the bottom of the film compartment, reaches a point between the two lines indicated on the cover of the pump. The oil cups on the projector main drive gears should then be lubricated with projector oil. These oil cups should receive one or two drops of oil daily.

*CAUTION: Before putting oil in the projector, make sure that the oil-drain petcock is closed.*

RCA projector oil can be obtained from all RCA Theatre Equipment Supply dealers. For best operation only genuine RCA projector oil should be used in RCA projector mechanisms. This oil was selected after extensive research in developing an oil that had all of the characteristics necessary for optimum performance.

Before turning on the soundhead drive motor, turn the projector mechanism over several times manually to make sure that it turns freely and without binding. After this has been checked, turn on the soundhead motor and allow the projector to run for several minutes until operating temperature has been reached.

Install the projection lens in the lens mount and clamp it into position. The standard mount is designed to take a Series No. 2 projection lens with an extension tube: Series No. 1 lenses may be used if provided with the proper type adaptor. Adaptors are available at all RCA Theatre Equipment Supply dealers. Adjust the lens focusing knob so that it is in the middle of its excursion. The projection lens can now be adjusted for approximate focus by projecting a light on the screen with the projector mechanism running, and adjusting the projection lens in the lens mount until a sharp focus of the aperture opening is obtained on the screen. After this approximate focus has been obtained clamp the projection lens firmly into position and align the projected image on the screen.

A motion-picture film may now be threaded in the projector; it is extremely important that the film be threaded accurately for proper operation. If the film does not engage correctly with the sprocket teeth and film gate, damage may result to the film. Care should be taken to make sure that the proper size loops exist both above and below the gate. When setting the loop above the gate it should be made so that the loop extends above the top of the gate approximately the width of two fingers. The loop between the intermittent sprocket and the lower take-up sprocket should be seven frames in length. See the film threading instructions in the operating section of this book for full details on threading film in the projector.

All RCA projector mechanisms are designed so that threading can be done easily, quickly and accurately; this will become apparent after the projectionist has become accustomed to them.

Before turning on the soundhead motor, turn the projector over manually a few times and check the threading to make sure that the sprocket teeth are engaged correctly in the film sprocket holes. Turn on the soundhead motor and watch the motion of the film through the projector mechanism to make sure that it is running properly through the gate and around the sprockets. Strike the arc and project the picture on the screen. Adjust the projection lens by means of the focusing knob for sharpest focus.

## OPERATION

### Lubrication

Once every 600 operating hours or after six months' use, whichever occurs first, the oil inside the projector mechanism should be completely drained from the oil-drain petcock and replaced with new RCA projector oil. The oil level must be maintained between the indicating lines on

the oil pump at all times when the mechanism is idle. It can not be checked when the projector mechanism is operating because most of the oil is then circulating throughout the gear compartment and the oil level at the pump is below the sight glass in the pump cover.

To replace the oil in the projector, drain the old oil by attaching a piece of medical hose to the oil-drain petcock so that the oil can be directed easily to a container placed on the projection room floor. Allow the oil to drain from the projector for a minute or two after the oil level has dropped below the sight glass in the oil pump cover. The oil filter screen in the oil gauge retaining housing should also be cleaned each time the oil is changed. To remove the oil filter screen simply remove the cover from the oil pump and the screen will be readily accessible; clean it thoroughly before replacing. When replacing the cover on the oil pump make sure that the round neoprene gasket is in good condition and set properly in place on the cover, otherwise an oil leak may develop. Before adding the new oil remove the rubber tubing from the oil-drain petcock and make sure that it is turned to its closed position. The new oil should be poured into the large oil cup on top of the gear-side cover.

The oil cups for the drive gear between the soundhead and projector mechanism should receive one or two drops of oil each day; use RCA projector oil for lubricating these parts.

**CAUTION:** When replacing the oil in the RCA projector mechanism use only genuine RCA projector oil. This is a special oil containing all characteristics necessary for optimum performance of the projector mechanism. Other types of oil may result in hard starting and possible damage to the mechanism.

### Threading

Good projection and assurance against film damage depends on correct and accurate threading of the film through the mechanism. The RCA-100 is so designed that threading can be done easily, quickly and accurately. Until the projectionist has become familiar with the threading, however, ample time and care should be used to make sure that it is done correctly.

Before threading the film through the mechanism open the film gate; move the upper and lower pad rollers away from their sprockets; turn on the framing light, and then turn the projector mechanism over manually until the intermittent sprocket is in its locked position. When the intermittent

sprocket does not turn with the rest of the mechanism it is in its locked position.

Pull the film down through the film trap until the starting mark on the film is directly opposite and completely covers the framing aperture located above the film gate. When the film is framed correctly in this aperture it will automatically be in frame at the picture aperture. Make sure that the film is wrapped snugly around the intermittent sprocket and then close the gate. Figure 8 shows the correct path of the film through the projector mechanism.

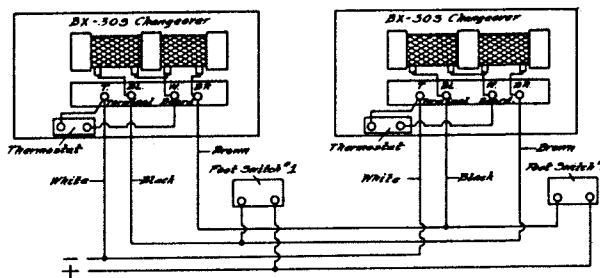

Figure 11—Wiring Diagram of MI-14313 Picture Changeover for Two Projector Operation

The loop of film above the film gate must be approximately the width of two fingers. The distance between the center of the picture aperture and the sound take-off must be  $14\frac{1}{2}$  inches or 19 picture frames; the loop between the intermittent sprocket and the lower take-up sprocket must be seven picture frames in length. Care should be taken in forming the film loops between the intermittent sprocket and the sound take-off to assure minimum film noise and prevent the possibility of film damage.

Wrap the film snugly around the upper and lower sprockets before closing the pad rollers against the film sprockets. Unless the sprocket teeth are engaged properly in the film-sprocket holes, damage may result to the film. Do not turn on the drive motor until the threading of the film has been checked carefully.

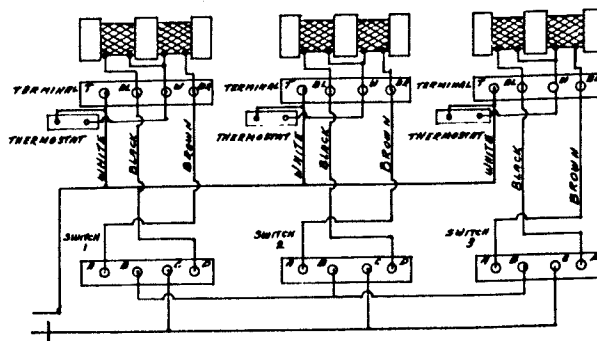

Figure 12—Wiring Diagram of MI-14313 Picture Changeover for Three Projector Operation

After the projectionist has threaded the film through the projector mechanism several times, the ease and simplicity of threading will become more apparent. In the beginning, however, the projectionist will be rewarded by taking extra time and care to make sure that this part of the operation is executed properly.

### **Operational Adjustments**

Several adjustments are provided which may be made when necessary, even while the mechanism is operating.

A shutter-timing vernier adjustment is provided inside the film compartment to the right of the upper sprocket assembly. The purpose of this adjustment is to compensate for any slight inaccuracy made when adjusting the timing of the shutters. Inaccuracy in the shutter timing adjustment manifests itself in the form of elongated white flashes commonly termed "travel ghost" which streak out from highlights in the picture. This streaking is most easily detected when running a film with white titles on a black background. If the streaking is upward from white objects, the adjusting stud should be turned to the left; if down, it should be turned to the right. This adjusting stud is easily turned with medium sized screwdriver. If sufficient latitude is not available in the adjusting screw to completely eliminate all "travel ghost", the shutters will have to be retimed. Instructions for making this adjustment are given in the section under "Maintenance."

The picture framing-knobs are located at the front of the projector mechanism and are easily and conveniently reached from either side. Turning the framing knob from one extreme to the other will move the film slightly more than the length of one full frame with respect to the picture aperture. Before threading the film in the mechanism the framing knob should be set so that the arrow on the knob points directly down. With the framing knob in this position it is midway between the extremes of its full excursion and ample latitude is provided for framing the film in both directions.

The lens focusing knob is located at the front of the lens mount and is easily accessible from both sides of the projector mechanism. During normal operation this adjusting knob should be set midway between the extremes of its full excursion so that ample latitude is available for moving the projection lens in either direction.

The film gate is designed so that an even and constant pressure is exerted on the film over the full length of the film gate. The amount of pressure against the film is controlled within a pre-

determined range by adjusting the X-1941 knurled thumb screw on the back of the gate. Changing the adjustment of this screw changes the pressure on all film tension pads simultaneously; the pressure cannot be increased or decreased beyond the limits where film damage might occur. The adjusting screw should be set for the minimum amount of tension on the film pads which will maintain a steady picture on the screen; keeping the tension on the pressure pads at a minimum will result in less wear on the intermittent sprocket teeth as well as on the film guides and shoes.

The only time that the tension on the film pressure pads may require readjusting is when unusual film conditions are encountered. In such a case the tension on the film pads should be adjusted to obtain the quietest operation consistent with a steady picture on the screen.

The tension on the intermittent sprocket pad should be adjusted for minimum film noise. This adjustment is set at the factory for average film conditions; readjustment in the field will be necessary only when unusual film conditions are encountered.

### **Cleaning**

Keeping the projector mechanism clean is one of the best ways of assuring highest quality projection. The interior of the film compartment of the RCA-100 is large and roomy; ample space is provided between all units to facilitate rapid and thorough cleaning of all parts. The light enameled interior of the main case aids in observing quickly dirt and other foreign matter, thereby making it easy for the projectionist to keep it clean.

The projectionist should cultivate the habit of cleaning all parts of the projector mechanism daily before the show starts. A clean rag and a small brush is all that is required to do a good cleaning job. The sprockets should be brushed around their entire periphery to remove all deposits of dirt and film emulsion; the pad rollers should also be brushed and then wiped clean with a rag; the film strippers should be checked and all dirt and emulsion deposits removed.

The most important unit in the film compartment to keep clean is the film trap and gate assembly. The film gate should be removed daily and thoroughly cleaned with a clean rag. The film shoes and guides on the film trap should be thoroughly cleaned with a clean rag making sure that all deposits of dirt and film emulsion are removed. Care should be taken when cleaning between the film guide rollers and the film trap main casting to remove all dirt and foreign matter which may prevent

their operating freely. Failure of the inner roller to turn when film is passing through the film trap may result in its becoming cut by the edges of the film. Once this roller has been cut it will be difficult to keep it turning and the only solution will be to replace it. The removable film aperture should be inspected daily and kept scrupulously clean. The film aperture is easily and quickly removed for cleaning. After the individual units in the film compartment are cleaned the entire interior of the film compartment should be wiped clean with a clean, dry rag.

*CAUTION: The mechanism should not be cleaned when it is running. Failure to adhere to this procedure may result in damage to the mechanism by getting the cleaning rag caught between the gears or tangled between the shutters and the shutter housing.*

The projection lens is easily and quickly removed for cleaning; it should be removed and cleaned daily so as to maintain maximum efficiency of light transmission and highest quality projection. Care should be used when cleaning the glass lenses to prevent scratching them, or coating them with a thin film of oil or grease. To guard against this use only lens tissue or a clean, soft rag.

#### Shear Pin

If abnormal strain such as a film pile-up is developed in the projector mechanism, the X-1729 shear pin shown in figure 2 will break and the projector mechanism will be mechanically uncoupled from the soundhead drive. In such a case, it is only necessary to remove the cause of the abnormal strain and replace the broken shear pin with a new one. To remove the broken parts of the shear pin, remove the X-1930 screw and pry them out with a screwdriver. The new shear pin will fit snugly into place and should be driven in its slot with the end of a screwdriver or a small hammer. Tighten the X-1930 screw against it.

## MAINTENANCE

The successful and efficient operation of any precision built machine such as a motion-picture projector mechanism depends on correctness of design, accuracy and precision of manufacture, and the care it is given during operation. If given only a reasonable amount of care the RCA-100 projector will perform over a period of many years with the same degree of accuracy as when new. It will actually run smoother and quieter after it has been run in for a few months, than when it was new.

## HOUSING UNIT

(See Parts Illustration No. 1)

There are only a few parts on the main case that will ever require adjustment or replacement, such as the glass parts in the door and covers, gaskets, and pilot lamps.

To replace the X-1003 neoprene gasket on the gear cover proceed as follows:—

1. Remove the gear cover from the main case and pull the old gasket from the cover.
2. Clean the mounting surface of the main case and the gear cover carefully; make sure that there is no foreign matter or burrs on either surface, otherwise oil leaks may develop.
3. Attach the new gasket to the gear cover, making sure that the edges of the gasket are in their normal position, and insert the three mounting screws in the gear cover.
4. Attach the gear cover to the main case, drawing all three screws up evenly and simultaneously. Do not tighten one screw all the way before drawing up the other two because it will then be difficult to draw the cover up evenly all around, and oil leaks may develop.

The large glass window in the gear cover is held in position with metal clips and can be removed simply by loosening the clips. A gasket is used against the window to prevent oil leaks; always make sure that this gasket is in good condition when replacing the glass, otherwise oil leaks may develop. The large glass in the film compartment door can be removed by first removing the two screws which attach the door handle.

The two pilot lights on the film side of the projector are easily accessible by removing the quarter panel and the shutter guard. Access to the pilot light on the gear side can be obtained by removing the gear cover.

#### Oil Drain Petcock

The X-7026 oil-drain petcock is attached to the front of the main case for standard theatre operation; for drive-in theatre operation, where an upward tilt exists, it should be attached to the rear of the projector. To remove the X-7026 petcock, proceed as follows:—

1. Drain all of the oil from the projector mechanism.
2. Remove the petcock, using a small adjustable end wrench.
3. If the petcock is to be moved to the rear of the main case for drive-in theatre operation, use the P-1225 brass plug removed from the rear of the main case to plug up the hole from which the petcock was removed.

4. When replacing the brass plug and the petcock, cover the threads with a thin layer of "Tite Seal" to prevent oil leaks.

### Upper Film Valve

The X-2231 and X-2232 film valve rollers in the X-3000 film valve must be kept clean and free from dirt so that they will turn freely at all times. If these rollers become clogged with dirt and stop turning, flat spots will develop and film damage may result.

These rollers can be removed for replacement or cleaning without removing the upper magazine by following the procedure outlined below:—

1. Insert a small diameter pin punch into the hole at the center of the roller.
2. Remove the X-2233 roller pivot screw.
3. The roller may now be lifted out of its housing.

### X-3701 INTERMITTENT UNIT

(See Parts Illustration No. 2)

A complete and detailed description of the RCA intermittent is given in the description section of this book; it was pointed out in this section that tolerances of less than a half of one ten-thousandth of an inch are held on most of the parts used in this unit. It is, therefore, extremely difficult to make major adjustments on this unit in the field; special tools and test equipment as well as experienced handling are essential. Listed below are the only adjustments that should be attempted in the field. Where any other work is required, obtain a loaner intermittent from the RCA Theatre Equipment Supply dealer and return the theatre's intermittent to the dealer for shipment back to the factory.

### Removal of Intermittent Sprocket

The intermittent sprocket can be replaced easily, accurately, and in less than one minute with no tools other than a large screwdriver. To remove the sprocket, proceed as follows:—

1. Remove the X-3014 quarter panel.
2. Bend the X-1959 film stripper away from the sprocket.
3. Turn the projector over manually to make sure that the intermittent is in its locked position.
4. Back out the X1-1109 left hand threaded retaining screw about a quarter of an inch by turning it to the right.
5. Place the middle and the forefinger of the right hand on opposite sides of the sprocket hub behind the outer flange, and the thumb against the X1-1109 sprocket retaining screw.

By pulling on the sprocket with the fingers and pushing inward on the head of the screw with the thumb, the sprocket will loosen from the shaft and come out as far as the screw.

6. Remove the X1-1109 screw and pull the sprocket from the shaft.

Before replacing the sprocket, make sure that the P-1054 screws are tightened firmly against the X1-1108A intermittent sprocket drive plate. When the sprocket is replaced on the shaft, make sure that the dogs in the X1-1108A drive plate engage in the slots in the end of the sprocket shaft. Replace the X1-1109 retaining screw and make sure that it is pulled up tightly against the sprocket.

To reverse the intermittent sprocket, remove the X1-1108A drive plate and attach it to the opposite end of the sprocket.

In every case make sure that the P-1054 screws are tight against the X1-1108A drive plate and that the X1-1109 retaining screw is pulled up tightly against the face of the sprocket, otherwise the intermittent will operate noisily.

*REMEMBER: the X1-1109 sprocket retaining screw has a left hand thread; turn it to the right to loosen it.*

### Removing Complete Intermittent

1. Remove the intermittent sprocket. (See above.)
2. Remove the X-3013 gear cover.
3. Loosen the P-154 lock nut and back off the X1-1112 screw releasing the X1-1111 steel clamp which locks the intermittent in position. (See Parts Illustration No. 3.)
4. Lift the X1-1111 steel clamp out of its casting with the left hand; pry the intermittent loose with a screwdriver placed so that it is resting on the main gear assembly shaft with the blade pushing the intermittent out.
5. When the intermittent is loose in its holding casting, swing it clockwise so that the lower casting clears the main frame and then pull it directly out.

### Replacing Complete Intermittent

1. Lift the X1-1111 steel clamp upward out of its casting.
2. Insert the sprocket shaft housing in the intermittent holding casting; make sure that the hole in the X-1114B yoke arm engages with the aligning pin in the X-3401 assembly.
3. Press the intermittent into its casting until the main casting of the intermittent unit is directly against its holding casting.

4. Press the X1-1111 steel clamp downward so that it drops into the retaining slot in the intermittent sleeve.
5. Tighten the X1-1112 screw in the steel clamp and lock in place with the P-154 nut.
6. Replace gear side cover and gasket. Make sure that both the gasket and the surface on the main case are wiped free of all dirt and oil.
7. Replace the intermittent sprocket and bend the X-1959 film stripper back into proper position.
8. Retime the light shutters.
9. Replace the quarter panel.

### Radius Adjustment

The adjustment of the star wheel with relation to the cam is referred to as the radius adjustment. It is set very carefully and accurately at the factory and adjustment in the field should rarely be necessary. If this adjustment is not made correctly, the intermittent may operate noisily.

Before attributing noisy operation of the intermittent unit to an incorrect radius adjustment, check the P-1054 and the X1-1109 screws on the sprocket locking plate to make sure that they are tight. Also check the inner edge of the sprocket to make sure that dirt has not built up between the sprocket and the main casting, thereby loading it and causing heavy indexing between the cam pin and the star wheel slots. Both of these conditions will result in excessive noise.

The radius adjustment can be checked very easily by quickly striking the periphery of the sprocket tangentially in the direction of its rotation with the side of the forefinger of the right hand while the projector is running without film. This should be done with the framing knob set at several different positions, ranging from one extreme to the other. The adjustment is correct when a slight clatter is heard each time the intermittent sprocket is struck with one's finger as described above.

The adjustment is too tight when a sharp clicking sound is heard continuously even when the projector is running with the film gate open and without film; no additional noise will be heard in this case when the periphery of the sprocket is struck with one's finger as described above. The radius adjustment is too loose when a pronounced clatter is heard each time the periphery of the sprocket is struck with one's finger. In this condition, the intermittent will usually be noisy when running either with or without film.

If the radius adjustment must be altered, refer to Parts Illustration No. 2 and proceed as follows:—

1. Remove the gear cover.
2. Loosen the P-155 nut with a thin  $\frac{3}{8}$ -inch end wrench. The thickness of the end wrench must be  $\frac{1}{8}$ -inch or less to fit into the recess where the nut is located.
3. Insert a 1/16-inch drift-pin punch in one of the holes around the shoulder on the X1-1127 cam bushing; the bushing should be rotated toward the star wheel shaft to tighten the adjustment, and away from the star-wheel shaft to loosen it. Do not turn the bushing more than 1/16-inch at the periphery before checking the adjustment again with the mechanism running. If the cam bushing is tight and can not be rotated as described above, place the end of the punch against the edge of one of the holes in the shoulder of the bushing and tap the punch sharply with a small machinist's hammer. Make sure that the bushing is not rotated more than 1/16-inch before checking the adjustment.
4. Tighten the P-155 lock nut and replace the gear cover.
5. Check the operation again by listening to the intermittent and by striking the periphery of the sprocket with the forefinger as described above.

If further adjustment is necessary the above procedure must be followed.

If the noise cannot be eliminated by changing the radius adjustment, arrangements should be made with the local RCA Theatre Equipment Supply dealer to have it repaired at the factory; the RCA dealer will furnish a loaner intermittent while these repairs are being made.

### Adjusting Sprocket Shaft End-Thrust

Excessive end thrust in the star wheel and sprocket can be eliminated by following the procedure outlined below:—

1. Remove the intermittent from the projector mechanism.
2. Remove the X-3106A oil scoop assembly.
3. Loosen the Allen screw in the star wheel shaft thrust collar. This collar can be reached by inserting a 3/32-inch Allen wrench through the round hole in the X-3109A intermittent sprocket sleeve.
4. Hold the star wheel tightly against the face of its bushing while at the same time pressing the thrust collar against the face of its bushing. The thrust collar can be pressed tightly against the face of its bushing by inserting the short end of a  $\frac{1}{8}$ -inch Allen wrench in the elongated hole in the X-3109A sprocket shaft and pressing it against the collar.

5. Tighten the Allen screw in the thrust bearing.
6. Replace the intermittent in the mechanism and retime the shutters.

### Adjusting Cam Shaft End-Thrust

There should be no perceptible end thrust in the cam shaft. To remove excessive end play, proceed as follows:—

1. Remove the intermittent unit from the mechanism.
2. Loosen the two P-1195 Allen head screws attaching the steel gear to the cam shaft.
3. Set the intermittent unit on its flywheel and tap the face of the gear snugly against its thrust bearing using a drift punch.
4. Tighten the two P-1195 Allen set screws attaching the steel gear to the cam shaft.
5. Turn the intermittent over manually several times to make sure that there is no binding; also check the end thrust in the cam shaft to make sure that all excess motion has been removed.
6. Replace the intermittent and retime the light shutters.
7. After the above adjustment has been made it is always a good idea to run the projector mechanism with the arc lamp operating for about fifteen minutes and then check the mechanism by turning it over manually to make sure there is no binding or tight spots.
8. If there is any binding or tight spots evident, remove the intermittent and tap the gear end of the cam shaft lightly with a small machinist's hammer to allow a small amount of clearance between the face of the gear and the face of its bearing.

### INTERMITTENT FRAMING UNIT

(See Parts Illustration No. 3)

#### Replacing X-1175 Framing Chain

1. Remove gear cover.
2. Remove upper sprocket drive gear and oil lubricator assembly.
3. Remove P-251 acorn nut and X1-1147 washer from X-1185A framing sprocket retaining stud.
4. Remove X-1930 screw which attaches X-1142 framing link to sprocket casting.
5. Remove X-1734 shoulder screw which attaches lower end of X-1142 framing link to X-1730 compensator arm.
6. Remove the two P-1010 and the two P-1005 screws which attach the X-3011 framing handle housing to the main case.

7. Slide the X-1194A framing sprocket casting from its stud and disengage the chain.
8. Drive out the P-190 pin which attaches each framing handle to the X-1176 small framing sprocket and disengage the framing handle assemblies from the sprocket. The chain will then be free.

When replacing the chain, make sure the framing handles are pinned to the X-1176 framing sprocket so that the arrow on each handle points in the same direction. Before attaching the X-3011 framing handle housing, clean the mounting surface on the main case and on the framing handle housing and then clean the X-1032 gasket and make sure the edges of it are not torn or cut, otherwise oil leaks may develop.

After all parts have been properly replaced, adjust the limiting screws on the top of the main case. These screws must be adjusted in the following manner.

1. Remove the acorn cap nuts and back out the screws several turns.
2. Frame the mechanism "downward" so that the X-1730 compensator arm is in its lowest position and rests against the X-1723 compensator main casting.
3. Adjust one limiting screw so that it is against the flat on the X-1194A sprocket casting, and then lock it in place with an acorn cap nut.
4. Frame the mechanism upward as far as it will go and then turn the mechanism over manually. If there is any trace of binding noticed frame it down slightly until it turns freely and then adjust the second limiting screw until it is against the flat on the X-1194A sprocket casting and lock it in place with an acorn cap nut.

### LOWER FILM SPROCKET UNIT

(See Parts Illustration No. 4)

Before removing the lower sprocket unit obtain a small tube of "Titesal" for applying to the mounting surface of the assembly and the main frame when the unit is being replaced. The entire assembly can be removed easily by following the procedure outlined below:—

1. Remove the X-1219 film stripper and the X-1221 locking spring.
2. Remove the three P-1000 mounting screws which hold the X-3203A assembly to the main frame.
3. Grasp the under side of the X-3200 sprocket, and X-1215 pad roller bracket and exert alternately an up, down, and sideward pressure



so as to free the assembly from the main frame.

4. Pull the assembly from the main frame.

### Replacing Lower Sprocket Assembly

1. Clean the mounting surfaces on the center frame of the main case and the sprocket assembly and apply a thin film of "Titesal" to both of these surfaces. The purpose of the "Titesal" is to prevent oil leaks from developing.
2. Insert the gear end of the assembly into the locating hole in the center frame so that the gears mesh properly.
3. Align the three mounting screw holes in the sprocket assembly with the three tapped mounting holes in the center frame and press the assembly firmly into position.
4. Cover the threads of the three P-1000 mounting screws with "Titesal" and then screw them evenly and firmly into their holes.
5. Replace the X-1219 film stripper and the X-1221 spring.

### Removing the Pad Roller Bracket Assembly

The X-3204 lower pad roller bracket assembly can be removed as a complete unit by removing the X-1217 retaining screw and pulling the bracket assembly away from its mounting stud.

The X-1245 pad rollers and the pad roller shafts can be removed from the bracket by removing the P-63 screw, turning the X-3206 shaft to the left and then pulling it out of the bracket; the X-1223 shaft can then be pulled out of the bracket and the X-1245 pad rollers will then be free.

### Pad Roller Adjustment

The distance between the pad rollers and the periphery of the sprocket is adjusted in the following manner:—

1. Loosen the P-155 nut on the pad roller bracket.
2. Move the pad roller bracket to its open position and wrap three thicknesses of film around the sprocket so that the sprocket teeth engage correctly with the sprocket holes in the film.
3. Close the pad roller bracket against the periphery of the sprocket and adjust the P-107 screw on the pad roller bracket until the pad rollers barely come in contact with the film. The pad rollers should be far enough away from the periphery of the sprocket so that they do not touch two thicknesses of film but just barely touch the film when three thicknesses are used.
4. Tighten the P-155 nut.

### Removing Sprocket

To remove the lower sprocket proceed as follows:—

1. Relieve the X-1219 film stripper by removing the front P-1035 screw and loosening the rear P-1035 screw.
2. Open the pad roller bracket by swinging it away from the sprocket.
3. Remove the X-1231 sprocket retaining screw. This screw has a left hand thread and must be turned to the right to remove it.
4. Pull the sprocket off of its shaft.

### UPPER FILM SPROCKET UNIT

(See Parts Illustration No. 5)

The upper sprocket assembly can be removed from the main frame easily by following the directions outlined below:—

1. Remove the cover from the gear side of the projector.
2. Remove the gear and lubricator assembly by first removing the X-1011 slotted cap nut. When removing this gear make sure that the P-1079 Woodruff key is in an upward position; otherwise, it may fall out and drop into the oil reservoir. The position of the key can be determined after the X-1011 slotted cap nut has been removed by checking the position of the key slot in the gear hub. If the key is not pointed upward, turn the complete mechanism manually by either the motor hand wheel or the flywheel.
3. Remove the P-78 screw and the X-1236 clamp which holds the oil tube in place. Take care not to drop them into the projector.
4. On the film side of the projector remove the X-1220 film stripper by removing the two P-1035 screws.
5. Remove the three P-1000 mounting screws which hold the sprocket assembly to the main frame.
6. Grasp the under side of the sprocket and pad roller bracket and exert alternate upward and sideward pressure to free the assembly from the main frame.

Before replacing this unit make sure that the mounting surfaces on the center frame as well as the sprocket assembly have been cleaned thoroughly. After these surfaces have been thoroughly cleaned spread a thin film of "Titesal" over one of these surfaces. The threads of the three P-1000 mounting screws should also be covered with "Titesal" before they are replaced. It is necessary that this precaution be taken to prevent oil leaks.

### Removing the X-3309 Pad Roller Bracket

The X-3309 upper pad roller bracket assembly can be removed as a complete unit by removing the X-1217 retaining screw and pulling the bracket assembly off its mounting stud.

The X-1245 pad rollers and the pad roller shafts can be removed from the bracket by removing the P-63 screw, turning the X-3206 shaft to the right, and then pulling it from the bracket; the X-1223 shaft can then be pulled out of the bracket and the X-1245 pad rollers will then be free from the bracket.

### Pad Roller Adjustment

The distance between the pad rollers and the periphery of the sprocket is adjusted in the following manner:—

1. Loosen the P-155 nut on the pad roller bracket.
2. Open the pad roller bracket by swinging it away from the periphery of the sprocket and wrap three thicknesses of film around the sprocket so that the sprocket teeth engage correctly with the sprocket holes in the film.
3. Close the pad roller bracket against the periphery of the sprocket and adjust the P-107 screw on the pad roller bracket until the pad rollers barely come in contact with the film. The pad rollers should be far enough away from the periphery of the sprocket so that they cannot touch two thicknesses of film but just barely touch the film when three thicknesses are used.

### Removal of Upper Film Sprocket

The upper film sprocket can be removed by following the procedure outlined below:—

1. Loosen the two P-1035 screws which hold the X-1220 film stripper in place.
2. Swing the pad roller bracket downward and away from the sprocket.
3. Remove the X-1231 sprocket retaining screw. This is a left hand thread and must be turned to the right to remove it.
4. Hold the X-1220 film stripper away from the periphery of the sprocket and pull the sprocket off of its shaft.

## LIGHT SHUTTERS AND SHUTTER DRIVE ASSEMBLY (See Parts Illustration No. 6)

### Removal of Shutter Blade Assemblies

The light shutter assemblies can be removed and replaced without disturbing the timing adjustment provided the shutter blades are not moved in their

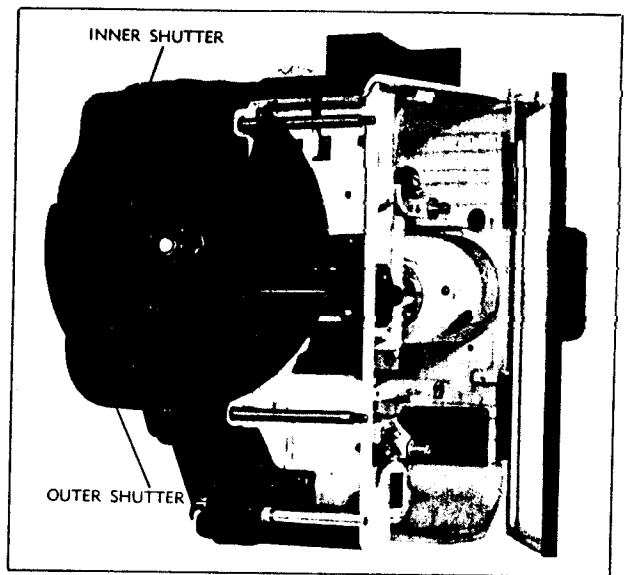

Figure 13—Position of Shutter Blades at Start of Intermittent Pull Down

flanges. To remove the light shutter assemblies, first remove the quarter panel and both sections of the shutter guard; loosen the X-1429 set screws in the shutter hubs and then pull the complete assemblies from their respective shafts.

### Retiming Shutters

Before retiming the light shutters set the X-3515 slotted adjusting stud at the center of its travel. This stud protrudes through the center frame into the film compartment directly opposite the upper sprocket casting. The center of its travel can be set by turning it as far as it will go in one direction and then turning it five full revolutions in the opposite direction. Proceed as follows to adjust the shutters:

1. Remove the quarter panels and both sections of the shutter guard.
2. Loosen the P-1032 and the P-1036 screws in the shutter hubs so that each shutter can be turned freely between its hub flanges.
3. Turn the projector over slowly by hand until the cam pin just starts to enter the star wheel slot. This is the point just before the intermittent sprocket starts to turn and can be determined quite accurately by wedging one's thumb lightly between the upper part of the sprocket and the lower edge of the film trap while turning the mechanism over slowly. It may be necessary to turn the mechanism past the point where the sprocket just starts to turn several times before being able to stop the mechanism exactly at that point.

4. Move the inner shutter blade in its flange, *being extremely careful not to turn the shutter shaft*, until the upper edge of the shutter blade cuts across the lower half of the picture aperture when looking across the edge of the shutter from the rear of the mechanism. It may be necessary to sight across the edge of the shutter blade from inside the lamphouse in order to obtain an accurate setting.
5. Tighten the P-1032 screws in the shutter blade flange being careful not to move the shutter shaft or change the position of the shutter blade in its flanges.
6. Move the outer shutter blade in a clockwise direction until the cutting edge of the blade is adjacent to the cutting edge of the inner blade, as shown in figure 13. In this position, the picture aperture will be completely covered.
7. Tighten the two P-1036 screws in the shutter hub.
8. Repeat step 3 and then check the position of the shutter blades. The blades should completely cover the aperture opening and the cutting edges should be adjacent to each other, as shown in figure 13, just as the cam pin enters the star wheel slot.
9. Replace the shutter guard and rear panel.
10. Project a picture on the screen, preferably one with titles, and check carefully for any trace of travel ghost. If a slight amount of travel ghost is noticed streaking upward, turn the X-3515 vernier adjusting screw to the left; if the streaking is downward, turn it to the right, until the ghost disappears. If the ghost cannot be eliminated with the X-3515 vernier adjustment, check the shutter timing again.

#### Removal of End Thrust—Inner Shutter Shaft

Excessive end thrust in the shutter shafts may cause longitudinal oscillation in the shafts and result in noise. To determine if excessive end thrust exists in the shutter shafts, remove the quarter panel and shutter guards and exert an alternate in-and-out pressure on each side of the shutter blade assemblies. There should be only a perceptible longitudinal movement in either shaft.

To take up excessive end thrust in the inner shutter shaft, remove the front 825142-1 plug in the framing handle housing and using a small drift punch, tap around the X-1428-B thrust collar lightly with a small hammer, while holding a heavy hammer or some other heavy metal object against the shutter end of the shaft, until a maximum of

.002" to .003" end thrust remains in the shaft. Turn the projector mechanism over manually and if there is any indication of binding, tap the front end of the shutter shaft very lightly while turning the projector over manually until it turns freely and without any trace of binding. It is always a good idea to run the projector for 15 or 20 minutes after making a shutter shaft adjustment to make sure that it will operate freely and quietly and does not develop any binds after it has reached normal operating temperature.

#### Removal of End Thrust—Outer Shutter Shaft

To remove excessive end thrust from the outer shutter shaft, proceed as follows:—

1. Remove the gear cover.
2. Remove the upper sprocket drive gear and lubricator assembly, the X-1142 vertical framing arm, and the X-3600D shutter main drive gear and bracket assembly.
3. Loosen the two P-1244 screws in the face of the slot in the X-1431B collar; these are the screws which are in the same radial plane and set 90° in relationship with each other.
4. Wedge a screwdriver between the lower P-1244 screw and the face of the slot in the X-1431B collar and tap the screwdriver with a small hammer until only a perceptible amount of end thrust remains.
5. Rotate the shaft to make sure it is not binding at any point. If binding is noticed, tap the X-1431B collar lightly while rotating the shaft and then tighten the P-1244 screws.
6. Replace all parts and retime the shutters.
7. Run the projector for 15 to 20 minutes with the arc lamp on to make sure that binding does not develop in the shutter shaft after the projector has reached its normal operating temperature.

#### Removing the Shutter Shaft Assembly

The complete shutter shaft assembly can be removed as a single unit by following the procedure outlined below:—

1. Remove the light shutter assemblies and the X-1426 shutter shaft oil slinger housing.
2. Remove the gear cover, the X-1142 vertical framing link, the upper sprocket drive gear and lubricator, and the X-3600D shutter shaft main drive gear assembly.
3. Remove the four P-1000 and the two P-1006 screws which attach the shutter shaft assembly to the housing.

4. Pull the complete shutter shaft assembly off of its dowels and away from the center frame. Move it through the hole in the back of the projector which was left open when the X-1426 shutter shaft oil slinger housing was removed, until the front end of the assembly is clear of the framing handle housing. The entire assembly can now be removed from the projector.

Before replacing this assembly, clean all mounting surfaces carefully on the center frame and on each unit. Coat the threads on all screws used for attaching units to the main frame with "Tite Seal" to prevent oil leaks developing. A thin coating of "Tite Seal" should also be applied to the mounting surface of the X-1426 shutter shaft oil slinger housing before it is attached to the main frame.

After all parts have been replaced, turn the mechanism over manually several times to make sure it turns freely and does not bind in any position. Retime the shutters and then allow the projector to run for several minutes.

#### Replacing Shutter Shaft Pinions

To remove the steel pinions from the shutter shafts, it is first necessary to remove the complete shutter shaft assembly by following the procedure outlined above. The X-1404A pinion on the inner shaft can then be removed by proceeding as follows:—

1. Remove the X-1428B collar from the end of the internal shaft.
2. Drive out the P-1078 taper pin which attaches the pinion to the shaft.
3. Insert a 1/8" drift punch into one of the holes in the external shaft directly behind its oil slinger and pry loose the X-1419 oil slinger on the internal shaft. It is important that this part be loose before driving out the internal shaft, otherwise the internal shaft may be damaged.
4. Push out the internal shaft and the X-1404A pinion will then be free.

To remove the X-1405B pinion on the outer shaft proceed as follows:—

1. Remove the X-3606 internal shaft, as described above.
2. Remove the two P-1244 screws which attach the X-1405B pinion to the X-1431B collar. These are the two screws which are in the same radial plane spaced 90° with each other.
3. Place a drift punch against the rear face of the 1/2" slot in the X-1431B collar and drive it off the X-1405B pinion. In some cases, the X-1431B collar can be driven up to the bear-

ing on the main casting, while still engaging the pinion. In such cases, insert a small metal object between the shoulder on the pinion and the face of the bearing on the main casting so that additional space will be provided for driving the collar.

4. To separate the X-3509 external shaft from the X-1431B collar, remove the remaining P-1244 screw, insert a drift punch in the X-1431B collar against the face of the shaft and drive it out of its bearing.

When reassembling the shutter shaft unit, apply a very thin coating of "Tite Seal" to the oil seal sleeve before pushing it into the external shaft. Adjust the thrust collars so that a perceptible amount of end thrust, approximately .002" to .003", is provided for each shaft. After the unit is completely assembled, oil it well and then turn it over manually several times to make sure it is not binding at any point. Approximately .003" to .004" backlash must be provided between the steel pinion gears and the X-3603C spiral bevel gear assembly which engages with the pinions. Instructions given in the following section covering the replacing of the X-3603C spiral bevel gear assembly give the procedure to follow in providing this backlash.

#### Replacing and Adjusting X-3603C Spiral Bevel Gear Assembly

It is necessary to remove the complete X-3600D drive assembly in order to replace the X-3603C gear assembly, but the end thrust and backlash between gears can be adjusted without the removal of the assembly. The procedure to follow when replacing the gear assembly is given below:—

1. Remove the gear cover.
2. Remove the upper sprocket drive gear and lubricator assembly and the X-1142 vertical framing link.
3. Remove the X-3600D drive unit from the shutter shaft casting by removing the four P-1000 screws and pulling the assembly off of its dowels.
4. Remove the X-1415B collar from the end of the X-3603C shaft and gear assembly and pull it directly out of the main casting. Be careful and do not lose the X-1456 Woodruff key in the shaft.

Before replacing the X-3603C assembly, slide the X-1415B collar on the shaft as closely as possible to the gear and then barely snug up on the P-1215 screw. Insert the X-1456 Woodruff key in the shaft and then slide the shaft into the main casting, guiding the Woodruff key into the keyway in the X-1406A gear. Mount the X-3600D drive assembly

on the shutter shaft main casting and fasten firmly with the four P-1000 screws. Adjust the position of the X-3603C gear assembly laterally so that approximately .003" to .004" backlash exists between the steel pinions and the celeron-gear, and then move the X-1415B collar next to the gear, firmly against the face of casting and tighten the P-1215 screw.

With .003" to .004" backlash between the spiral bevel drive gear and the pinions, a movement of between  $\frac{1}{8}$ " and  $\frac{3}{16}$ " will exist at the periphery of the shutter blades when the X-3603C gear is held absolutely stationary. After the X-1415B collar on the gear end of the shaft has been adjusted for the proper amount of backlash between gears, attach the X-1415B thrust collar to the end of the shaft, allowing .002" to .003" end thrust; this should be checked with the gear rotated to several different positions.

After all parts have been replaced, turn the mechanism over manually to make sure that it is not binding at any point, retime the shutters and then allow the projector to run for 15 to 20 minutes with the arc lamp on to make sure that binding does not develop when the projector is operating at normal temperature.

#### **Removing the X-1406A Shutter Timing Gear**

To remove the X-1406A shutter timing gear, remove the X-3600D unit and then proceed as follows:—

1. Remove the X-3603C spiral bevel gear assembly.
2. Loosen the P-1041 Allen screws in the X-1410A thrust collar and remove it from the X-1406A gear.
3. Turn the X-3515 stud to the left until the X-1432 shutter adjusting yoke becomes disengaged from the X-1406A gear.

After the gear has been replaced, snug up on the P-1032 friction screw in the X-1432 yoke so that the X-3515 shutter timing shaft is held firmly by the yoke but not so tight that it cannot be turned with a screwdriver. Turn the projector over manually several times to make sure it is not binding at any point and then retime the shutters.

#### **GOVERNOR AND FAN UNIT (See Parts Illustration No. 7)**

The governor and fan unit operates at a relatively high speed; care must be taken when servicing this unit to make sure that it rotates freely and shows no indication of binding after the projector mechanism has reached its normal operating temperature.

#### **Replacing X-3700 Governor Head**

The governor head can be replaced as a single unit by loosening the P-1026 screw under one of the weights and then pulling the complete assembly from its shaft. To replace this unit, place a screwdriver blade behind the X-3703 gear hub and exert a pressure to push this gear and shaft toward the governor head and then slide the governor head on its hub, allowing approximately .002" end thrust. The end thrust should be checked with the governor head rotated to several different positions.

#### **Replacing X-3506 Governor Assembly**

1. Remove the upper sprocket drive gear and oil distributor.
2. Loosen the P-1038 Allen set screw which attaches the X-1501 fan to the governor shaft.
3. Remove the three P-1000 screws holding the governor assembly in place and then remove the governor assembly.

Before replacing the governor assembly, make sure that the mounting surface on the main frame and on the governor assembly are cleaned thoroughly and then proceed as follows:—

1. Coat the mounting surface on the governor assembly and center frame with a thin film of "Titesal".
2. Replace the governor assembly on the main frame and at the same time slide the rotary fan in the governor shaft. Make sure that the mounting holes in the governor main casting line up with the screw holes in the main frame.
3. Apply "Titesal" to the threads of the three P-1000 mounting screws and screw them into their holes. Do not tighten them.
4. Locate the rotary fan on the governor shaft so that it is halfway between the sides of its housing in the main frame casting, rotate the fan so that the P-1038 Allen set screw is over the flat on the governor shaft and then tighten the P-1038 screw locking the fan to the shaft.
5. There must be no perceptible backlash between the X-3704 and X-3703 governor gears. The backlash between these gears can be removed by loosening the P-1188 Allen set screw which locks the X-1515A eccentric shaft into position, and then turning this shaft until all backlash has been removed. Do not mesh the gears too tightly or they may bind and become noisy. After the adjustment has been made, lock the X-1515A shaft into position by tightening the P-1188 Allen set screw.

6. Replace the upper sprocket drive gear, and check the mesh between it and the X-3704 governor idler gear to make sure that approximately .002" and .003" backlash exists between all teeth. To obtain the correct amount of backlash, move the entire governor assembly on its mounting screws and then tighten the three P-1000 mounting screws.

### **X-3907 MAIN DRIVE GEAR UNIT** (See Parts Illustration No. 8)

The X-3907 main drive gear unit couples the gear train in the projector mechanism to the soundhead. To remove the complete drive unit, proceed as follows:—

1. Drain the oil from the projector mechanism and remove the gear cover.
2. Remove the intermittent unit and the X-3903B shutter compensator gear unit by following the procedure outlined on page 30.
3. Loosen the P-1009 screw at the rear of the main case and remove the X-3906 gear and X-3913A shaft assembly.
4. Rotate the X-3907 gear assembly until the small end of the X-1759 pin is pointing upward and then drive the pin through the shaft using a 1/8" drift punch. When knocking the pin through the shaft, make sure that the drift punch is seated firmly on the end of the pin and then hit the punch with a clean, sharp blow using a small machinist's hammer so that the first blow will loosen the pin.
5. After the pin has been removed, pull out the X-1705 main drive shaft and the X-3905 gear. The X-1704 gear will then be free to be removed.
6. To remove the X-3912 bronze bearing, remove the three P-1025 screws and pry the bushing loose.

Before replacing the X-3907 main drive unit, wipe all of the mounting surfaces carefully so that they are absolutely clean, and proceed as follows:—

1. Mount the X-3912 bronze bearing in its mounting hole so that the three recesses along the periphery of the bushing line up with the screw holes in the main projector casting. Before pressing this bearing all the way into the housing, place the X-1705 shaft through the bearing and into the X-1707A bearing so it will act as a guide in correctly aligning the bearings concentrically as the X-3912 bearing is being pressed into position.
2. Replace the three P-1025 screws.
3. Hold the X-1704 gear in position and replace the X-1705 shaft and X-3905 gear.

4. Align the tapered hole in the X-1705 shaft with the tapered hole in the X-1704 gear and replace the X-1759 taper pin. Make sure the gears rotate freely and show no indication of binding.
5. Replace the X-3906 gear and X-3913A shaft and tighten the X-1009 screw against the flat on the shaft.
6. Replace the shutter compensator assembly and the intermittent. Turn the mechanism over manually to make sure that it is free from binding. Time the shutters and add a sufficient quantity of oil in the projector so the level will appear between the two indicator lines on the oil gage.

### **OIL PUMP UNIT** (See Parts Illustration No. 9)

One pint of Brenkert lubricating oil is required to fill the oil pump in the projector. When pouring oil in the projector a small funnel should be used so that oil will not spill over the gear cover. The oil should be removed and replaced with fresh oil after approximately 600 hours of operation. To drain the oil, slip a short length of gas or medical hose over the nozzle of the oil-drain petcock so that the lubricant can be directed easily to a container placed on the projection room floor.

Whenever the oil is changed the X-1621A oil filter screen in the X-3806A cover assembly should be removed and cleaned. This can be accomplished in the following manner:—

1. Remove the X-3806A cover assembly from the oil pump by first removing the two P-82 screws.
2. Remove the X-1621A bronze screen from the bottom of the pump and clean thoroughly with kerosene.
3. Insert the X-1621A screen in its housing in the X-3806A cover assembly and replace it on the oil pump.
4. Make sure that the X-1617 gasket is in good condition and set properly when the cover is replaced; otherwise, an oil leak may develop. If this gasket is stretched and does not fit snugly around the edge of the cover, a new gasket should be used.

### **Removing Oil Pump From Main Frame**

1. Drain oil from the projector.
2. Remove the four P-1000 mounting screws.
3. Grasp the X-3806A cover assembly and exert a slight alternate up and down pressure until the pump is free from the main frame.

4. Pull the pump away from the projector main frame as far as the X-1622 neoprene hose will allow.
5. The neoprene hose may now be removed from the pump by loosening the screw in the P-1109 clamp and pulling the hose from the copper tubing on the pump.

Before replacing the pump examine the X-1625 gasket carefully and if it is broken in any place it should be replaced with a new gasket. Proceed as follows when replacing the pump on the main frame:—

1. Clean the mounting surfaces on the main frame and the oil pump and then seat the X-1625 gasket on the dowel locators in the main frame.
2. Attach the neoprene hose to the copper tubing in the pump and tighten the screw in the P-1109 clamp.
3. Mount the oil pump in the main frame so that it is seated on its dowel locators and pressed firmly against the mounting surfaces of the main frame. Make sure that the oil pump gear is meshed correctly with its drive gear and that the X-1625 gasket is held in its correct position.
4. Cover the threads of the four P-1000 screws with a thin film of "Titesal" and then screw them into the mounting holes of the pump and draw them up evenly and tightly.
5. Close the oil drain petcock and pour fresh oil into the projector.
6. Turn the projector over by hand several times before starting the motor.

#### **X-3903 SHUTTER COMPENSATOR UNIT** (See Parts Illustration No. 10)

##### **Removal of Complete Unit**

To remove the complete X-3903D shutter compensator gear unit, proceed as follows:—

1. Remove the intermittent.
2. Remove the X-1142 vertical framing arm.
3. Remove the upper sprocket drive gear and oil distributor assembly. When removing this unit, be careful so that the Woodruff key in the shaft does not drop into the oil sump.
4. Remove the X-3600D shutter shaft drive assembly by removing the four P-1000 screws.
5. Disconnect the X-1170 horizontal framing link from the X-1730 bracket by removing the X-1734 screw.
6. Drive the P-182 pin out of the X-1717A shaft and X-3900A gear and pull the shaft out of its housing. The X-3900A gear assembly will then be free to be removed.

7. Remove the three P-1000 screws which attach the compensator to the main housing and then pull the compensator from its dowel pins.

##### **Replacing X-3901A and X-1719A Spline Gears**

1. Remove the X-3903B shutter compensator gear unit.
2. Drive out the P-1071 pin which attaches the X-1726 sleeve to the X-1712 spline shaft.
3. Pull out the X-1726 spline retaining sleeve and push the X-1712 shaft out of the assembly. The X-1730 compensator arm will then be free to be removed.
4. Remove the X-1731 washers and X-1721 and X-1722 spline nuts. These may be removed by inserting the little finger of one hand in the ends of the main casting and pulling the parts out.
5. The X-3901A and X-1719A gears are now free and can be removed.

To reassemble this unit, proceed as follows:—

1. Place the spline gears into position and insert the X-1721 and X-1722 spline nuts with a X-1731 thrust washer at each end. Make sure that the spline nuts are engaged with each other.
2. Replace the X-1730 bracket and hold it in its lowest position against the X-1723 main casting.
3. Insert the X-1712 spline operating shaft, engaging its splines with the grooves in the X-1730 bracket.
4. Replace the X-1726 spline retaining sleeve. If the hole in the X-1726 sleeve does not line up exactly with the hole in the X-1712 shaft, push the shaft slowly and carefully out of its housing until its splines disengage with the slots in the X-1730 compensator arm. When the spline shaft has become disengaged, rotate it sufficiently to allow the splines in the shaft to engage with the next set of slots in the X-1730 arm. Check again to see if the holes in the X-1726 sleeve and X-1712 shaft line up correctly; if they do not, repeat the above procedure until they are correctly aligned and then drive the P-1071 pin into the hole. Do not let either end of the pin protrude above the surface of the sleeve which would cause binding when it enters the end of the X-1730 arm.
5. Check the operation of the unit by swinging the X-1730 compensator arm from one extreme to the other. The travel in each direction should be limited by the arm striking the main casting.

6. Adjust the X-1754 screws to allow only a perceptible amount of end thrust, not over .002", and then lock the screws in place by tightening the P-154 nuts.

### **STANDARD LENS MOUNT** (See Parts Illustration No. 11)

The lens mount can be removed from the projector as a complete unit by removing the two P-1007 screws and sliding it out of the main case.

#### **Radial Adjustment of Lens Carriage**

There must be no perceptible radial movement in the lens carriage, yet it must slide freely in and out of its housing when the focus adjusting knob is turned. To remove radial movement in the lens carriage, proceed as follows:—

1. Remove the projection lens and disconnect the lens mount from the main case.
2. Loosen the P-1038 Allen set screw which locks the X-1812 guide pin.
3. Loosen the P-1033 screw which controls the friction on the X-4001A focusing screw.
4. Turn the X-1812 guide pin so as to remove all radial or side play from the lens carriage and then lock it into position with the P-1038 Allen set screw.
5. Check the movement of the lens carriage by turning the focus adjusting knob from one extreme to the other. The lens carriage should move freely in the lens mount without any binding and there should be no radial or side motion of the lens carriage at any setting in the lens mount casting.
6. Tighten the P-1033 screw which controls the friction on the X-4001A focusing screw until a comfortable amount of pressure is required to turn the focusing knob.
7. Attach the lens mount to the main case and replace the projection lens.

#### **Removal of Excess End Thrust in Lens Carriage**

There must be no perceptible backlash in the lens mount carriage. If backlash is present, it can be removed by following the procedure outlined below:—

1. Remove the lens mount from the projector.
2. Loosen the P-483 lock nut on the end of the focus adjusting screw and tighten the inner P-483 nut until all backlash is removed. Do not draw this nut up too tightly or it will prevent the focus adjusting screw from turning smoothly.
3. Tighten the rear P-483 lock nut and attach the lens mount to the main case.

#### **Adjusting Tension on Focusing Knob**

The amount of pressure required for turning the focus adjusting knob is controlled by the P-1033 screw in the split casting for the focus adjusting screw. This screw must be drawn up just tight enough so that the focus adjusting knob can be turned comfortably.

### **FILM TRAP AND GATE**

(See Parts Illustration No. 13)

#### **Removal of Picture Aperture**

The X-1908B picture aperture plate can be removed by swinging the X1-1924 aperture plate release handle toward the rear of the mechanism and then pulling the removable aperture toward the rear and straight out of its housing.

#### **Adjustment of Automatic Fire Shutter**

With the projector running, the fire shutter must rise sufficiently to expose the entire opening of the aperture. With the projector idle, the fire shutter must cover the aperture completely but without dropping far enough to strike the bottom of its housing casting.

If the fire shutter does not operate as described above, remove the film trap unit and inspect the bronze bushing on the end of the X-4110C operating rod. A slight amount of wear on the end of this bushing will do no harm, but if it is worn  $3/32$ " or more below the original surface, replace it with a new one.

After the X-4110C operating rod has been inspected and found to be satisfactory, or replaced with a new one, adjust the operation of the fire shutter by following the procedure outlined below:—

1. Replace the film trap in the projector mechanism.
2. Observe the location of the fire shutter with respect to the aperture opening. If the fire shutter does not drop low enough to cover the entire aperture when the projector is idle, force it downward sufficiently to completely cover the aperture but not enough to rest on the bottom of its housing casting; otherwise the governor weights will rattle when the projector is slowing down to a stop.
3. If the fire shutter drops all the way to the bottom of its housing when the power is turned off, prop the fire shutter to its open position, place a screwdriver against the knob on the X-4109 angle link and tap it lightly with a small hammer so as to bend the angle link slightly. Allow the fire shutter to drop



in its housing and observe if it completely covers the aperture without striking the bottom of the slot. If it does fall all the way to the bottom of the housing, repeat the above procedure until the correct adjustment is made.

4. Start the projector mechanism and observe the action of the fire shutter. It should move up quickly after the projector has reached approximately two-thirds normal speed, and expose the entire area of the shutter.

### Removing Film Trap

The film trap unit can be removed easily and quickly as one complete unit for cleaning and servicing. To remove the unit, follow the procedure outlined below:—

1. Remove the quarter panel and the adjacent shutter guard.
2. Remove the X1-1924 aperture plate release handle and the two P-63 screws which attach the X1-1928 shield to the film trap casting.
3. Remove the changeover shutter.
4. Remove the P-1000 screw at the bottom of the X-1903 sub casting and swing it backward so that the X-1959 stripper is clear of the intermittent sprocket.
5. Remove the P-1000 screws which attach the film trap casting to the center frame and lift the unit from its dowel pins. Do not allow the film trap to fall on the intermittent sprocket as it may burr the sprocket and cause film damage.

### Lateral Guide Roller Assembly

The X-4107 lateral film guide roller assembly can be removed easily without removing the film trap assembly from the main frame by following the procedure outlined below:—

1. Remove the quarter panel and shutter guard.
2. Remove the X1-1924 aperture plate release handle and the X1-1928 shield.
3. Loosen the P-1018 screw which holds the outer X-1958 guide roller center pin and pull it out of its bearing.
4. Remove the complete X-4107 guide roller assembly from the film trap casting.

When replacing and adjusting the lateral guide roller assembly proceed as follows:—

1. Replace the guide roller assembly in the film trap casting; make sure that the tension spring is toward the inside of the trap casting.
2. Slide the X-1958 center pin into its bearing and position the lateral guide roller assembly

so that it will be supported at its centers by the inner and outer X-1958 center pins.

3. Loosen the P-1018 screw which holds the inner X-1958 pin, hold a straight edge (such as a 6" steel scale) firmly against the X-1907A outer film guide and then move the X-4107 guide roller assembly laterally until the inside of the outer roller barely touches the straight edge.
4. Make sure that the X-1958 center pins engage with the X-4107 film guide assembly without allowing excessive end play and then tighten the P-1018 screws.

### Film Guide Adjustment

The X-1907A film guide strips can be adjusted without removing the film trap unit from the projector. An X-1993 aligning gage is necessary to make this adjustment accurately. To adjust the guide strips proceed as follows:—

1. Remove the projection lens mount assembly.
2. Remove the film gate and the intermittent sprocket.
3. Loosen the X-1989 screws on the X-1907A outer film guide strip and then draw them up until the film guide strip is held snugly but not tightly.
4. Loosen the two P-1053 screws in the side of the film trap casting and pull the outer film guide toward the edge of the casting.
5. Slide the X-1993 gage over the intermittent sprocket shaft and swing it between the film guide strips, making sure that it is held firmly against the inner film guide.
6. Tighten the P-1053 screw slowly while at the same time moving the X-1993 gage between the film guides until the gage starts to bind slightly between the guide strips. The guide strip must be adjusted so that the friction between it and the gauge is the same over its full length.

### Replacing Film Slide Strips

1. Remove the film trap unit from the main frame.
2. Remove the X-1989 and the X-1994 screws which attach the X-1904A film slide strips and the X-1907A film guide strips to the film trap casting.
3. Install the new X-1904A film slide strips (or the original strips may be reversed if they are worn on one side only) and the X-1907A film guides; snug up on the attaching screws but do not tighten them until after the X-1907A film guide strips have been adjusted.

4. Press the inner X-1907A film guide firmly against the shoulder on the main casting and tighten the X-1989 and the X-1994 screws.
5. Place the X-1993 film guide aligning gage between the film guides, adjust the outer guide until the full length of it fits snugly against the aligning gage and then tighten the X-1989 and X-1994 screws.

### FILM GATE

(See Parts Illustration No. 14)

The film gate can be removed by loosening the X-1943 knurled thumb screw and pulling the gate from its mounting bracket. When replacing the gate, position it on its mounting base so that the holes in the gate engage with the dowel pins in the sub base and then tighten the X-1943 screw.

### Adjustment of Film Tension Pads

The film tension pads must be adjusted for the minimum amount of tension on the film consistent with a steady picture on the screen. When projecting different types of film it may be necessary to change the tension on these pressure pads in order to obtain a steady picture on the screen. To increase the tension it is simply necessary to turn the X-1941 adjusting screw to the right; to decrease the tension, turn the screw to the left.

### Adjustment of X-1964A Intermittent Sprocket Pad

Adjust the X-1935-2 cap nut on the intermittent sprocket pad for the quietest running of film. Normal adjustment of this pad is to screw the X-1935-2 cap nut on the threaded stud until the top of the nut is flush with the end of the stud. It should not be necessary to change this adjustment after it is once set.

### Adjustment of the X-4114 Film Pad Springs

1. Remove the film gate from the projector mechanism.
2. Remove the X-1986 and X-1987 screws which attach the X-4113 front plate and lift this plate from the main gate casting.
3. The X-4114 spring assemblies can be replaced simply by removing the P-1054 screw which attaches them to the vertical shaft.
4. All of the film pad tension springs must be adjusted so that they are in the same plane as the X-1952 adjusting arm. To adjust the springs it is simply necessary to bend them.

### Replacement of X-1978 Gate Closing Spring

The X-1978 gate closing spring can be replaced without removing the film gate sub base unit by following the procedure outlined below:—

1. Remove the X-1942 toggle link swivel screw which attaches the spring to the sub base movable casting.
2. Remove the X-1930 gate lever retaining screw and pull the complete X-1916 gate operating lever from its mounting stud.
3. The spring can then be removed by removing the X-1934 toggle link connecting screw.

When replacing the spring make sure that the ends of the spring do not protrude beyond the normal plane of the spring. Also make sure that no burrs exist on the end of the spring. Attach the end of the spring to the gate operating lever using the X-1934 screw and then insert the X-1942 screw through the X-1944 gate closing link and X-1978 gate closing spring, making sure that the loop in the spring rests on the shoulder of the screw. Slide X-1916 gate operating lever on its stud, being careful that the loop in the gate closing spring does not fall off of the shoulder on the X-1942 screw, and then tighten the X-1942 screw firmly in position and replace the X-1930 gate lever retaining screw.

### MI-14312 PICTURE CHANGEOVER UNIT

(See Parts Illustration No. 15)

#### Replacing X-4200 Shutter Actuating Assembly

To replace this assembly, proceed as follows:—

1. Remove the changeover unit from the projector.
2. Remove the P-1085 headless screw, the X-2014 spring, and the P-212 ball.
3. Loosen the P-161 hex nut and screw the X-4209 out of the fork casting.

#### Removing the X-4203 Field Coil Assembly

To remove the X-4203 field winding assembly, proceed as follows:—

1. Remove the complete changeover unit.
2. Disconnect the wires from the coil.
3. Remove the X-4200 shutter actuating fork.
4. Unscrew the X-2004 end plate from the main housing and slide out the coil assembly.

A friction adjustment is provided to hold the X-4200 actuating guide fork in position and prevent the assembly from sliding forward, especially where a steep projection angle exists. To increase the friction, tighten the P-1085 screw.

To adjust the travel of the changeover shutter, proceed as follows:—

1. Loosen the P-161 hex nut.
2. Turn the X-4209 threaded shaft counter clockwise if the shutter is not dropping far enough or clockwise if the shutter falls too far.
3. Tighten the P-161.

## MI-14313 PICTURE CHANGEOVER UNIT

(See Parts Illustration No. 15A)

Instructions covering adjustment of this changeover unit are given on page 16.  
The MI-14313 changeover is manufactured by Essannay Electric Mfg. Company, Chicago, ILL.

## REPLACEMENT PARTS SECTION



## MAIN CASE UNIT

<i>Part No.</i>	<i>Description of Part</i>
X-1003	Gasket; gear compartment cover.
X-1006	Housing; shutters, rear.
X-1007	Housing; shutters, front.
X-1011	Nut; shutter housing studs.
X-1016	Sub plate; magazine.
X-1022	Clip; glass retainer.
X-1024	Clip; quarter panel glass retainer.
X-1028	Handle; film compartment door.
X-1029	Screw; door stop, shoulder.
X-1038	Cushion; glass.
X-1051	Window; quarter panel.
X-1052	Glass; gear cover, large.
X-1053	Glass; film compartment door.
X-1054	Glass; gear cover, small.
X-1058	Nut; quarter panel stud.
X-1059	Screw; gear cover retainer, long.
X-1061	Gasket; gear cover window, small.
X-1062	Hinge; film compartment door.
X-1063	Gasket; gear compartment window, large.
X-1064	Link; door stop.
X-2230	Casting; upper film valve.
X-2231	Roller; upper film valve, large.
X-2232	Roller; upper film valve, small.
X-2233	Screw; film valve rollers.
X-3000	Film valve assembly.
X-3012	Door assembly; film compartment.
X-3013	Gear cover assembly complete.
X-3014	Quarter panel assembly complete.
X-7016	Screw; gear cover retainer, short.
X-7026	Bib cork; oil drain.
24275	Monogram.
P-79	Screw; 8-32 x $\frac{3}{8}$ ", rd. hd.
P-81	Screw; 8-32 x $\frac{1}{2}$ " fl. hd.
P-83	Screw; 8-32 x $\frac{3}{4}$ ", rd. hd.
P-1009	Screw; $\frac{1}{4}$ "-20 x $3\frac{1}{4}$ ", fl. hd.
P-1010	Screw; $\frac{1}{4}$ "-20 x 4", fl. hd.
P-1013	Screw; $\frac{1}{4}$ "-20 x $\frac{5}{8}$ ", flat head.
P-1018	Screw; 6-32 x $\frac{1}{4}$ ", fl. head.
P-1018B	Screw; 6-32 x $\frac{1}{4}$ ", fl. head.
P-1030	Screw; 4-40 x $\frac{3}{16}$ ", flat head.
P-1100	Door latch.
P-1100A	Door strike.
P-1103	Washer.
P-1296	Pin; $\frac{3}{32}$ " x $\frac{5}{8}$ ", groove.
P-1312	Oil cup.

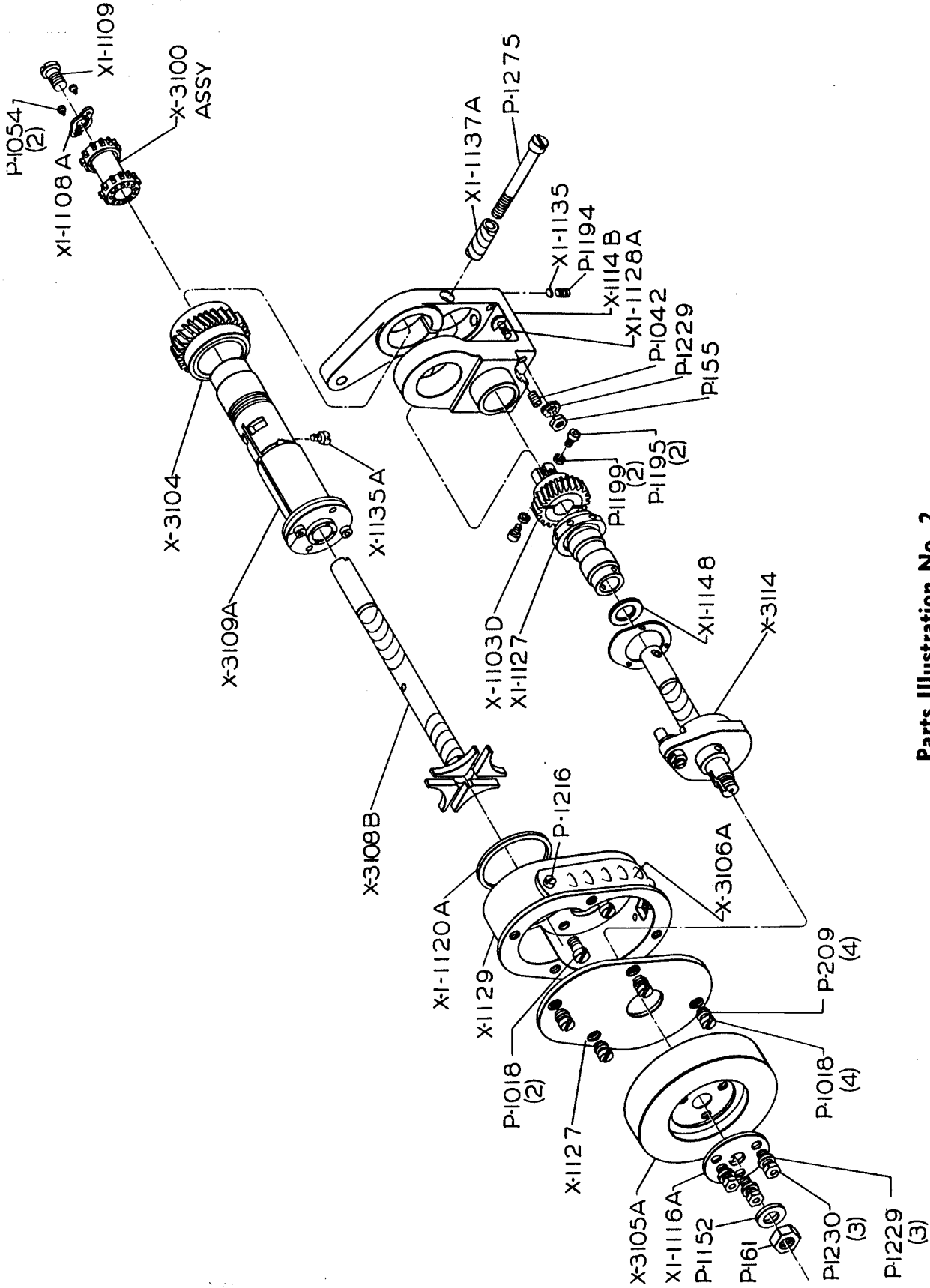

Parts Illustration No. 2  
 INTERMITTENT UNIT ASSEMBLY

## INTERMITTENT UNIT ASSEMBLY

<i>Part No.</i>	<i>Description of Part</i>
X-1103D	Gear; cam shaft.
X-1114B	Casting; main frame.
X-1127	Cover; oil box.
X-1129	Oil box.
X-1135A	Screw; sleeve lock.
X1-1108A	Plate; intermittent sprocket.
X1-1109	Screw; sprocket lock.
X1-1116A	Washer; flywheel.
X1-1120A	Gasket; oil box.
X1-1127	Bearing; cam shaft.
X1-1128A	Pin; cam shaft bearing lock.
X1-1135	Plug; lock screw.
X1-1137A	Spring; swivel pressure screw.
X1-1148	Washer; cam shaft thrust.
X-3100	Sprocket assembly.
X-3104	Gear assembly.
X-3105A	Flywheel assembly.
X-3106A	Scoop & screen assembly.
X-3107C	Intermittent unit complete.
X-3108B	Star & shaft assembly.
X-3109A	Quill and bushing assembly.
X-3114	Cam & shaft assembly complete with index pin and roller.
P-155	Nut; 10-24, hex.
P-161	Nut; 5/16-24, hex.
P-209	Lock washer.
P-1018	Screw; 6-32 x 1/4", fil. hd.
P-1042	Screw; 10-32 x 1/4", set.
P-1054	Screw; 2-56 x 1/8".
P-1152	Washer, <small>LOCK</small>
P-1194	Screw; 10-32 x 3/8", soc. set.
P-1195	Screw; 8-32 x 1/4", soc. head.
P-1199	Lockwasher.
P-1216	Screw; 6-32 x 1/8", fil. hd.
P-1229	Washer.
P-1230	Screw; 10-32 x 3/8", socket hd.
P-1275	Screw; 2 1/2 x 28 x 1/4", socket hd.



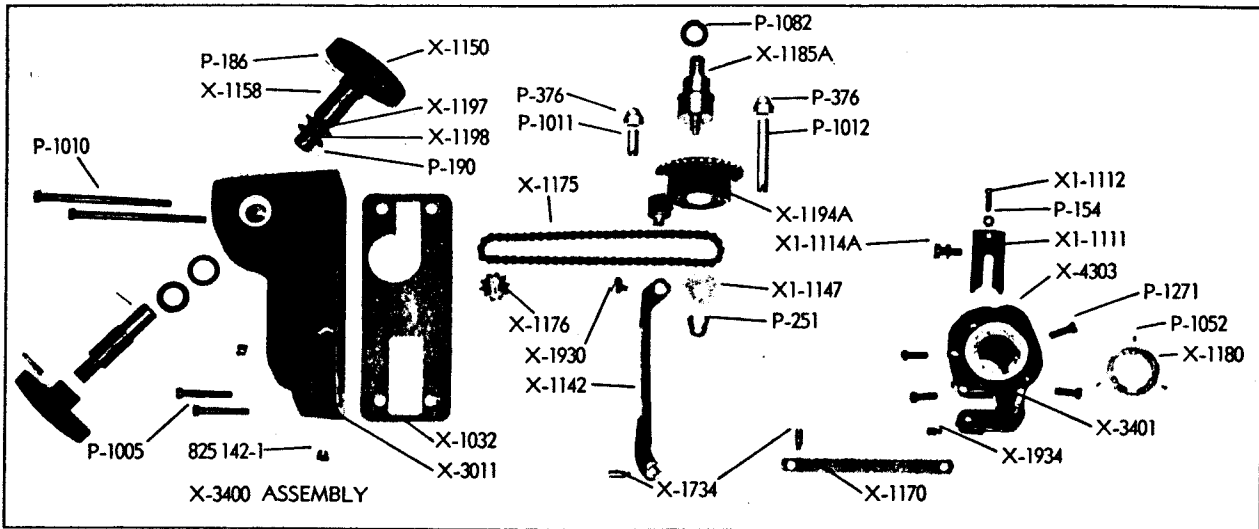

### Parts Illustration No. 3 FRAMING & INTERMITTENT HOLDING UNIT

<i>Part No.</i>	<i>Description of Part</i>
X-1032	Gasket; framing handle housing.
X-1142	Arm; framing, vertical.
X-1150	Knob; framing, right and left.
X-1158	Shaft; framing.
X-1170	Link; framing, lower.
X-1175	Chain, framing.
X-1176	Sprocket and shaft; framing, small.
X-1180	Washer; framing arm retainer.
X-1185A	Screw; framing swivel.
X-1194A	Housing; framing sprocket.
X-1197	Washer; framing shaft, thrust.
X-1198	Washer; oil seal.
X1-1111	Clamp; intermittent holding.
X1-1112	Screw; intermittent holding clamp.
X1-1114A	Screw; intermittent clamp.
X1-1147	Washer; framing sprocket thrust.
X-1734	Screw; framing arm swivel.
X-1930	Screw; vertical arm to sprocket.
X-1934	Screw; framing link, lower.
X-3011	Housing; framing knob.
X-3400	Housing assembly, complete with knobs and chain.
X-3401	Arm assembly; framing.
X-4303	Holding assembly; intermittent (less X-3401 arm)
P-154	Nut; 10-32, hex.
P-186	Pin; $\frac{1}{8}$ x $\frac{7}{8}$ " groove.
P-190	Pin; $\frac{1}{8}$ x $\frac{3}{8}$ " groove.
P-251	Nut; $\frac{3}{8}$ -24, acorn.
P-376	Cap nut; $\frac{1}{4}$ x 20.
P-1005	Screw; $\frac{1}{4}$ -20 x $1\frac{1}{2}$ " fil. hd.
P-1010	Screw; $\frac{1}{4}$ -20 x 4" fil. hd.
P-1011	Screw; framing stop, short.
P-1012	Screw; framing stop, long.
P-1052	Screw; 2-56 x $\frac{3}{16}$ " flat hd.
P-1082	Washer; $\frac{7}{8}$ " x $\frac{1}{2}$ " x $\frac{1}{8}$ ", lock.
P-1271	Screw; $\frac{1}{4}$ -20 x $\frac{3}{8}$ ", fil. hd.
825 142-1	Plug.

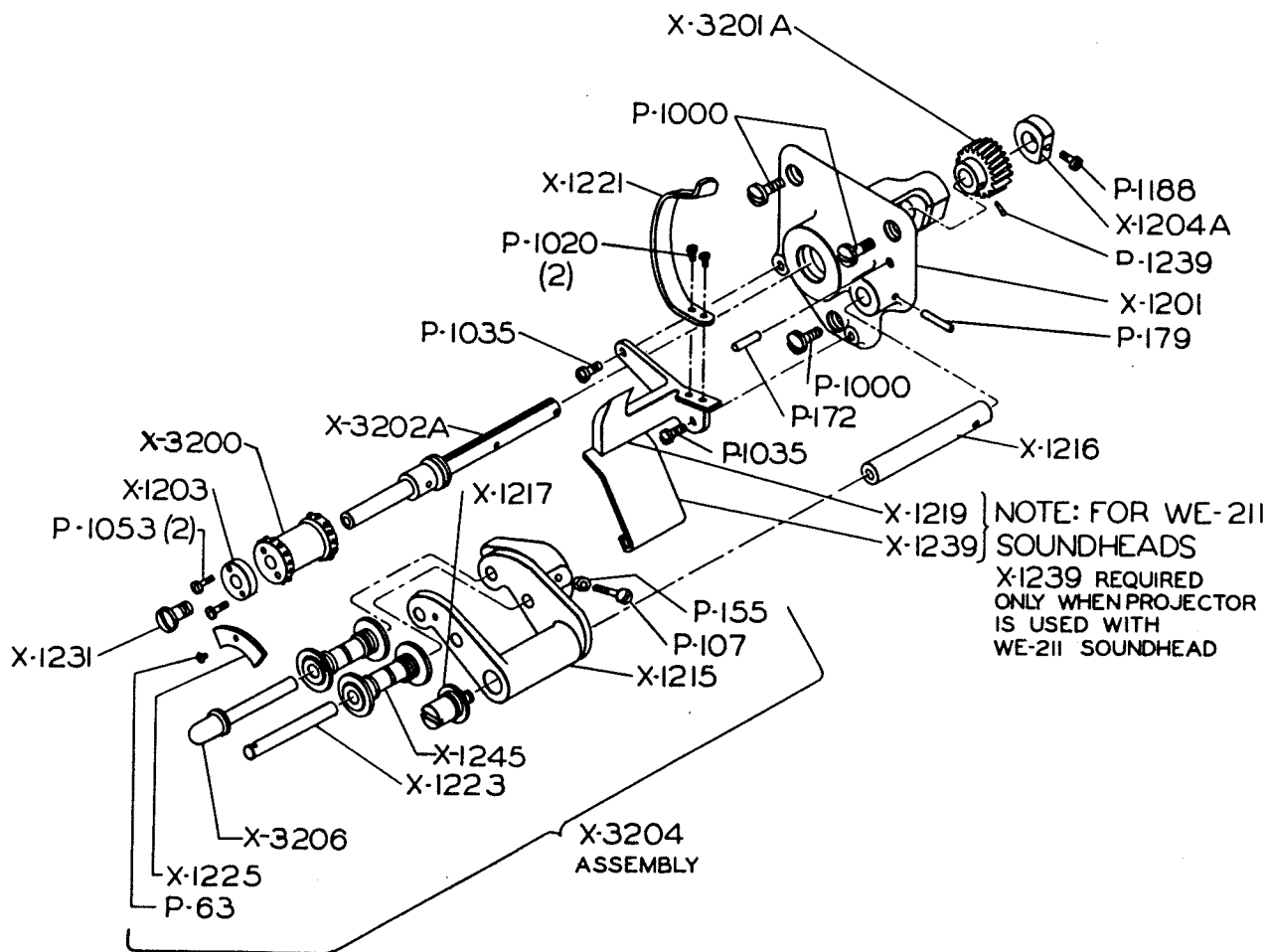

**Parts Illustration No. 4  
LOWER FILM SPROCKET UNIT**

<i>Part No.</i>	<i>Description of Part</i>
X-1201	Main casting.
X-1203	Plate; sprocket driving.
X-1204A	Collar; sprocket shaft.
X-1215	Bracket; pad roller retainer.
X-1216	Stud; pad roller bracket.
X-1217	Screw; bracket retainer.
X-1219	Stripper.
X-1221	Spring.
X-1223	Shaft; pad roller, rear.
X-1225	Plate; pad roller shaft retainer.
X-1231	Screw; sprocket retaining.
X-1239	Stripper (used with WE-211 soundhead only).
X-1245	Pad roller.
X-3200	Sprocket complete.
X-3201A	Gear; sprocket drive.
X-3202A	Shaft.
X-3207	Lower film sprocket drive, complete. (Less X-3204 and X-3200)
X-3204	Pad roller bracket assembly, complete.
X-3206	Shaft; front pad roller.

<i>Part No.</i>	<i>Description of Part</i>
P-63	Screw; 6-32 x $\frac{3}{16}$ ", oval head.
P-107	Screw; 10-24 x $\frac{3}{4}$ ", rd. hd.
P-155	Nut; 10-24, hex. hd.
P-172	Pin; $\frac{3}{16}$ " x $\frac{7}{8}$ ".
P-179	Pin; $\frac{3}{32}$ " x $\frac{3}{4}$ ".
P-1000	Screw; $\frac{1}{4}$ -20 x $\frac{3}{8}$ ", fl. hd.
P-1020	Screw; 6-32 x $\frac{3}{16}$ ", fl. hd.
P-1035	Screw; 10-24 x $\frac{3}{8}$ ", fl. hd.
P-1053	Screw; 2-56 x $\frac{1}{4}$ ", fl. hd.
P-1188	Screw; 8-32 x $\frac{3}{8}$ ", soc. hd.
P-1239	Pin; 3/0 x $\frac{3}{8}$ " taper.

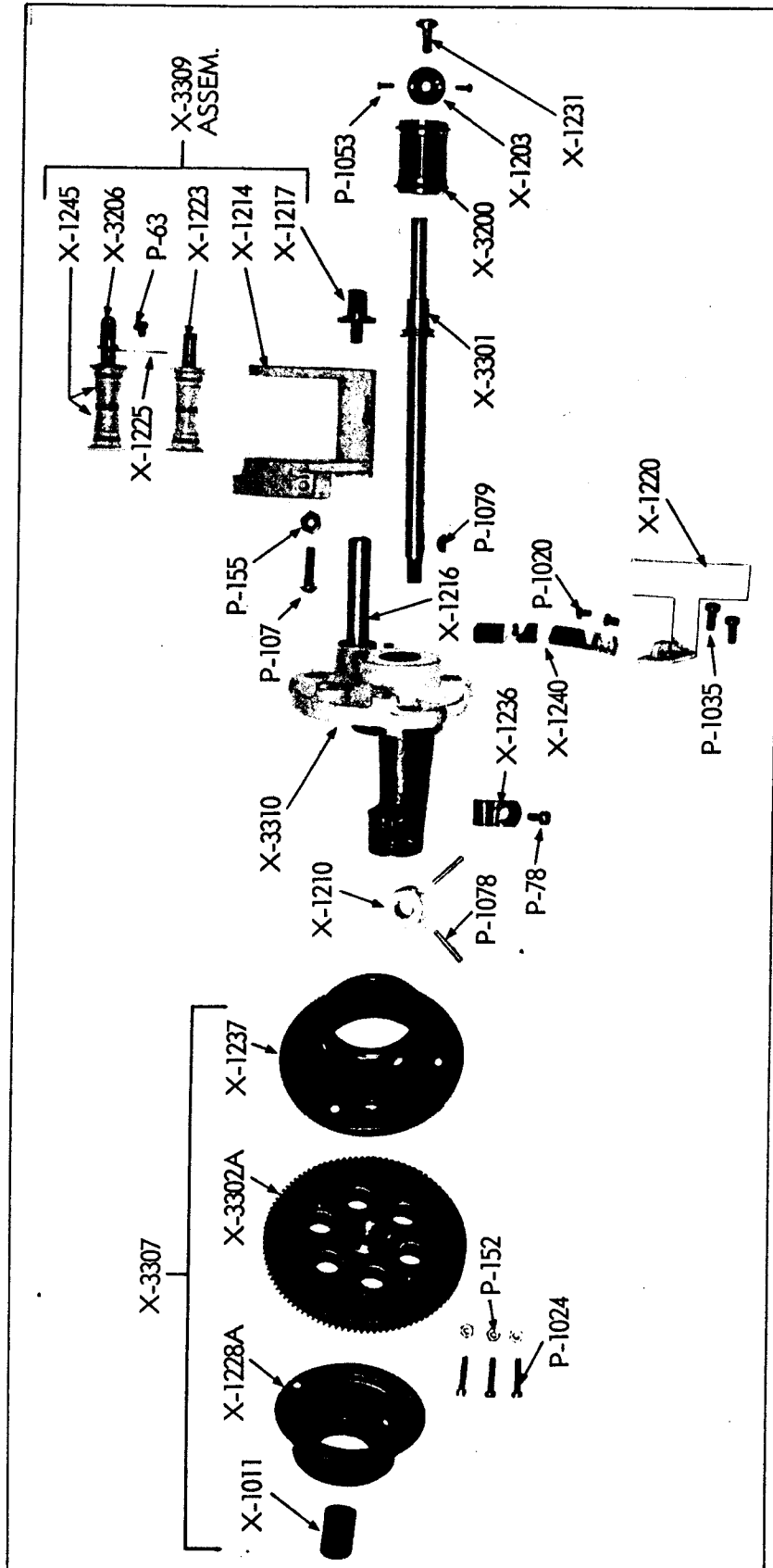

Parts Illustration No. 5  
 UPPER FILM SPROCKET UNIT

## UPPER FILM SPROCKET UNIT

<i>Part No.</i>	<i>Description of Part</i>
X-1011	Nut; upper sprocket drive gear retainer.
X-1203	Plate; sprocket drive.
X-1210	Collar; upper sprocket shaft thrust.
X-1214	Bracket; upper pad roller.
X-1216	Stud; pad roller bracket.
X-1217	Screw; bracket retaining.
X-1220	Stripper; upper sprocket, film.
X-1223	Shaft; pad roller, rear.
X-1225	Plate; pad roller shaft retainer.
X-1228A	Distributor; main oil, front.
X-1231	Screw; sprocket retaining.
X-1236	Clip; oil tube fastening.
X-1237	Distributor; oil, rear.
X-1240	Spring; upper pad roller bracket.
X-1245	Roller; film pad.
X-3200	Sprocket assembly.
X-3206	Shaft assembly; pad roller.
X-3301	Shaft assembly; upper feed sprocket.
X-3302A	Gear assembly; upper sprocket drive.
X-3305	Housing and upper sprocket shaft assembly; includes X-3301 and X-3310 assemblies.
X-3307	Gear and oil distributor assembly.
X-3309	Bracket assembly; upper pad roller.
X-3310	Housing and stud assembly.
P-63	Screw; 6-32 x 3/16", oval head.
P-78	Screw; 8-32 x 1/4", fl. head.
P-107	Screw; 10-24 x 3/4", round head.
P-152	Nut; 6-32, hex.
P-155	Nut; 10-24, hex.
P-1000	Screw; 1/4-20 x 3/8", fl. head.
P-1020	Screw; 6-32 x 3/16", fl. head.
P-1024	Screw; 6-32 x 3/8", fl. head.
P-1035	Screw; 10-24 x 3/8", fl. head.
P-1053	Screw; 2/56 x 1/4", fl. head.
P-1078	Pin; 3/0 x 3/4", taper.
P-1079	Key; woodruff #213.

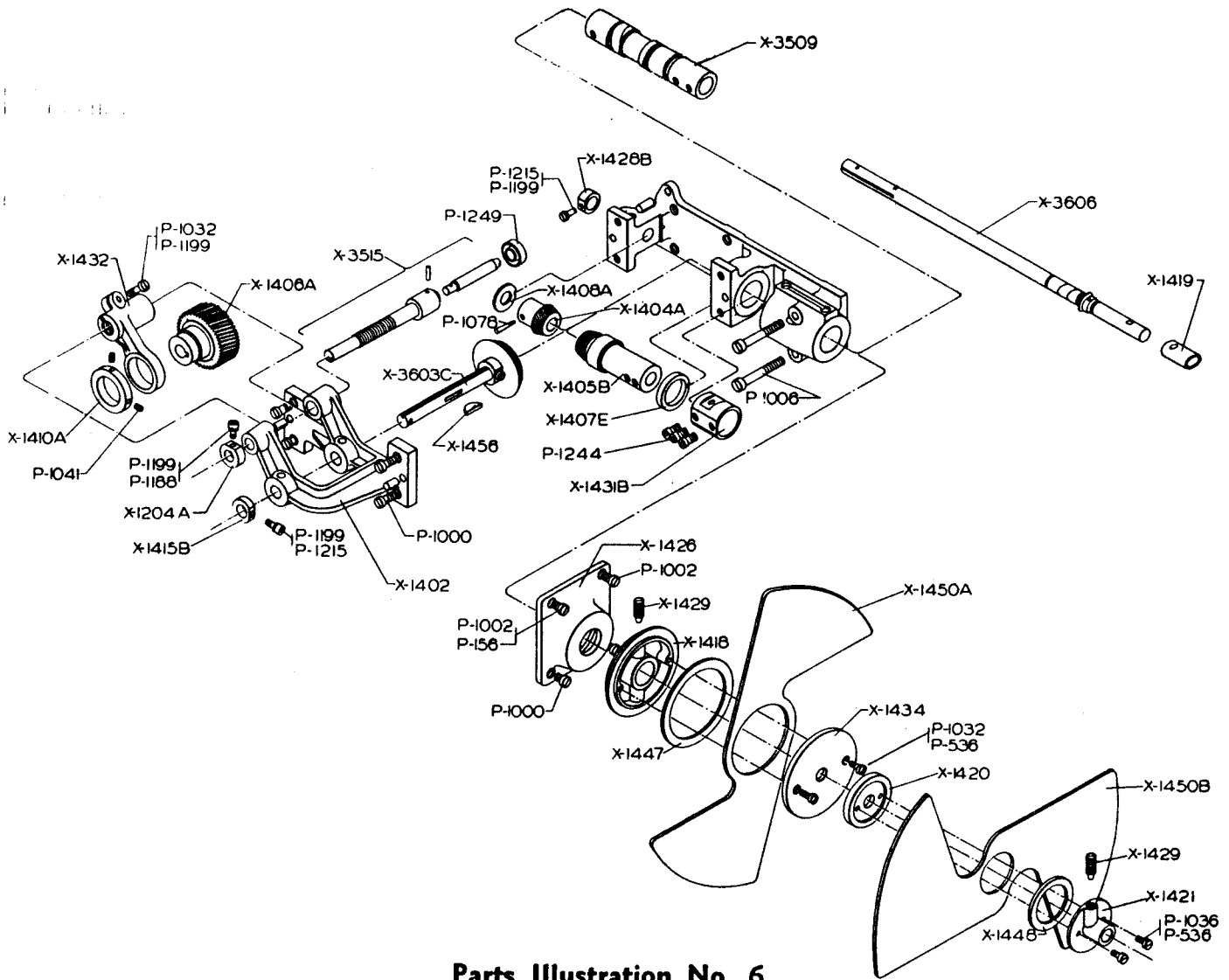

**Parts Illustration No. 6**  
**SHUTTER SHAFT ASSEMBLY**

<i>Part No.</i>	<i>Description of Part</i>
X-1204A	Collar; shutter adjusting vernier shaft.
X-1402	Casting; shutter drive shaft.
X-1404A	Gear; internal shaft, bevel.
X-1405B	Gear; external shaft, bevel.
X-1406A	Gear; double face adjustable drive.
X-1407E	Washer; bevel pinion thrust, large.
X-1408A	Washer; bevel pinion thrust, small.
X-1410A	Collar; double face gear.
X-1415B	Collar; bevel gear drive shaft.
X-1418	Flange; inner shutter.
X-1419	Oil slinger; internal shaft.
X-1420	Retainer; outer shutter flange.
X-1421	Flange; outer shutter.
X-1426	Housing; shutter oil slinger.
X-1428B	Collar; internal shaft thrust.
X-1429	Screw; cone point set.
X-1431B	Collar; external shaft.
X-1432	Yoke; shutter adjusting.
X-1434	Retainer; inner shutter flange.
X-1447	Gasket; inner shutter.
X-1448	Gasket; outer shutter.
X-1450A	Shutter; inner.
X-1450B	Shutter; outer.
X-1456	Key; shutter drive shaft.
X-3509	Shaft and bushing assembly; external shutter drive.

<i>Part No.</i>	<i>Description of Part</i>
X-3515	Shaft assembly; shutter timing.
X-3600D	Main drive pinion and bracket assembly.
X-3603C	Gear and shaft assembly, large spiral bevel.
X-3606	Shaft assembly; internal shutter drive.
X-3605D	Double shutter shaft unit, complete but less shutters.
175180	Shutter blade assembly; outer, complete with flanges.
175181	Shutter blade assembly; inner, complete with flanges.
P-156	Nut; 1/4-20, hex. hd.
P-536	Lockwasher.
P-1000	Screw; 1/4-20 x 3/8", fil. hd.
P-1002	Screw; 1/4-20 x 3/8", fil. hd.
P-1006	Screw; 1/4-20 x 1 3/4", fil. hd.
P-1032	Screw; 10-24 x 1/2", fil. hd.
P-1036	Screw; 10-24 x 3/8", fil. hd.
P-1041	Screw; 10-32 x 3/16", fil. hd.
P-1078	Pin; 3/0 x 3/4", taper.
P-1188	Screw; 8-32 x 3/8", soc. head.
P-1199	Lockwasher.
P-1215	Screw; 8-32 x 1/2", soc. hd.
P-1244	Screw; 10-32 x 1/4", soc. hd.
P-1249	Oil seal.

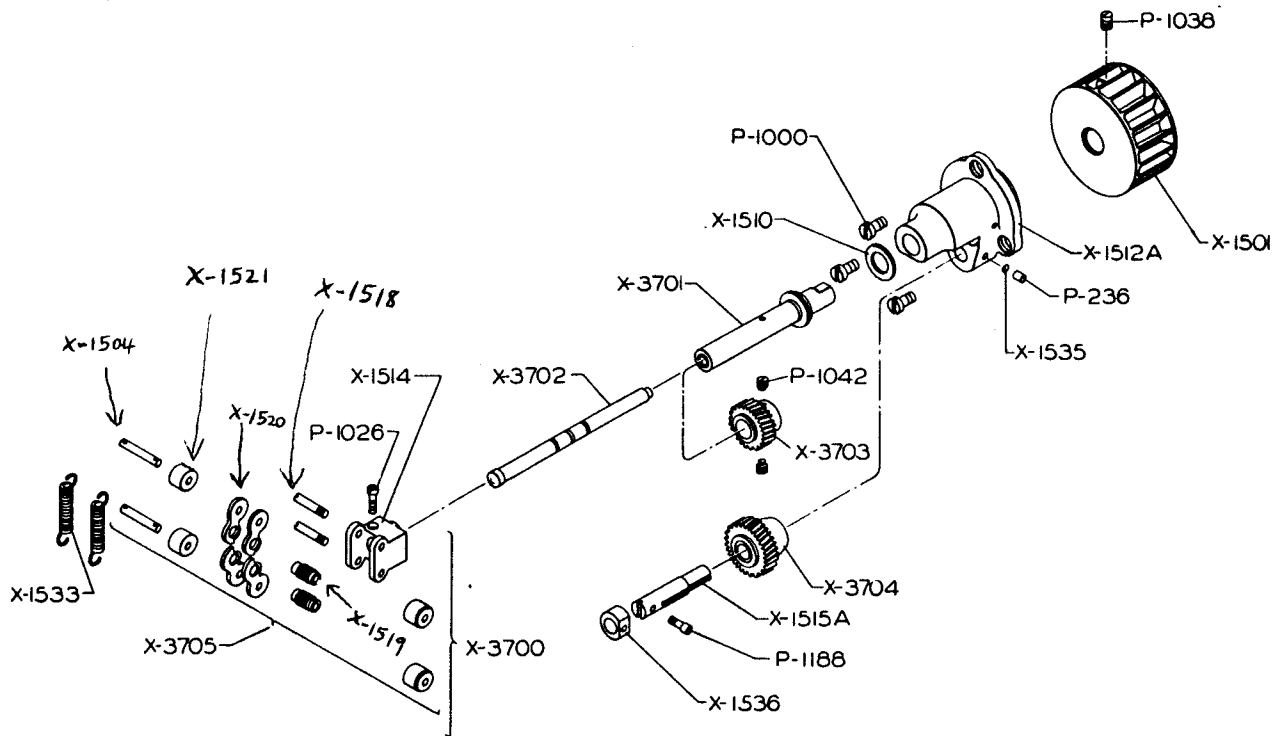

## Parts Illustration No. 7 GOVERNOR AND FAN ASSEMBLY

<i>Part No.</i>	<i>Description of Part</i>
X-1501	Blower.
X-1510	Washer; governor head thrust.
X-1512A	Main casting; governor assembly.
X-1514	Head; ball and lever mounting.
X-1515A	Shaft; idler gear mounting.
X-1533	Spring.
X-1535	Plug.
X-1536	Collar; idler gear thrust.
X-3700	Governor head assembly, complete.
X-3701	Sleeve and shaft assembly.
X-3702	Push rod assembly.
X-3703	Gear assembly; governor drive.
X-3704	Idler gear and brushing assembly.
X-3705	Weight and sleeve lever assembly.
X-3706A	Governor assembly, complete less blower.
P-236	Screw; 10-24 x 1/4", cup point.
P-1000	Screw; 1/4-20 x 3/8", fil. head.
P-1026	Screw; 6-40; socket head set.
P-1038	Screw; 10-24 x 1/4", cup point set.
P-1042	Screw; 10-32 x 1/4", headless set.
P-1188	Screw; 8-32 x 3/8", soc. head.
X-1504	PIN, GOVERNOR WEIGHT HOLDING
X-1518	SHAFT, BALL AND LEVER
X-1519	SLEEVE, WEIGHT SWIVEL
X-1520	WEIGHT AND SLEEVE LEVER
X-1521	WEIGHT

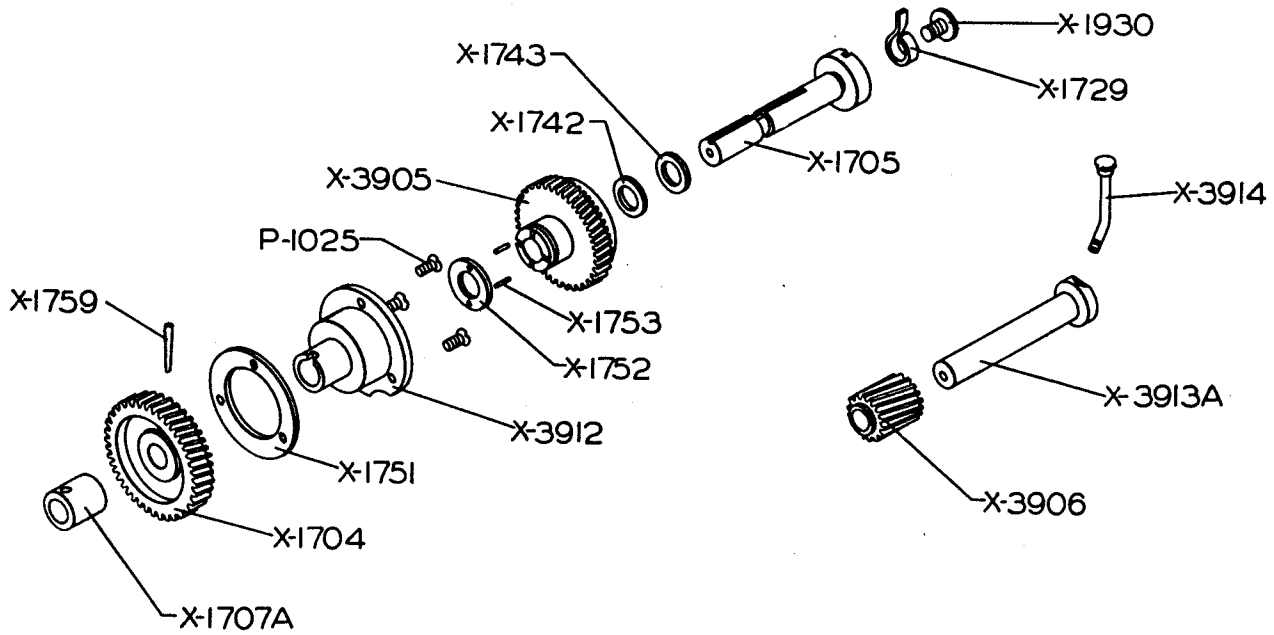

**Parts Illustration No. 8  
MAIN DRIVE GEAR UNIT**

<i>Part No.</i>	<i>Description of Part</i>
X-1704	Gear; main drive, inner.
X-1705	Main drive shaft.
X-1707A	Bearing; drive shaft, internal.
X-1729	Shear pin.
X-1742	Washer; main drive oil seal.
X-1743	Washer; oil stop.
X-1751	Gasket; main bearing oil seal.
X-1752	Washer; main bearing thrust.
X-1753	Pin; main bearing thrust washer.
X-1759	Pin; special taper.
X-1930	Screw; shear pin retainer.
X-3905	Gear assembly; main drive.
X-3906	Idler gear and bushing assembly.
X-3907	Main gear assembly, complete less X-3913A shaft and X-3906 gear assembly.
X-3912	Bearing assembly; drive shaft.
X-3913A	Shaft assembly; double-faced gear.
X-3914	Oil tube and cup assembly.
P-1025	Screw; 4-40 x 3/8", flat head.

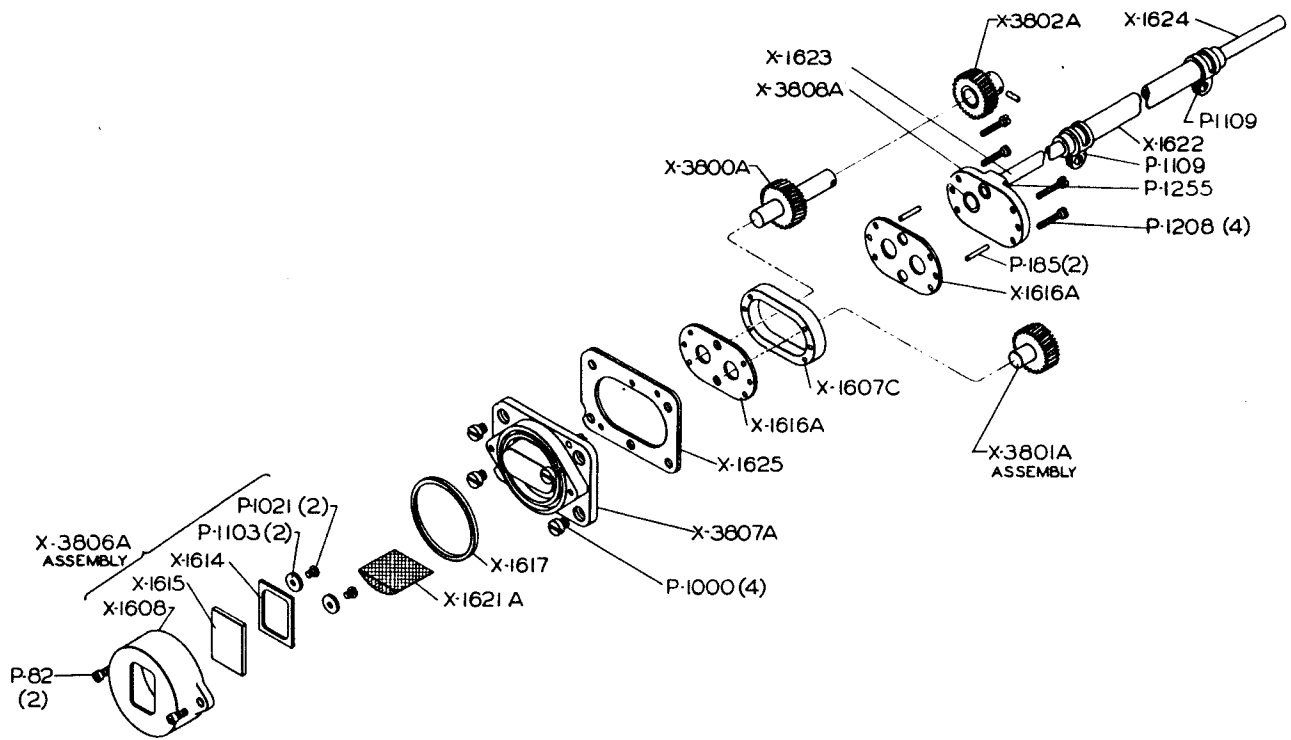

## Parts Illustration No. 9 OIL PUMP UNIT

<i>Part No.</i>	<i>Description of Part</i>
X-1607C	Spacer; oil pump body.
X-1608	Cover; oil pump, external.
X-1614	Gasket; sight glass.
X-1615	Glass; oil gauge.
X-1616A	Spacer; body gear thrust.
X-1617	Gasket; oil pump cover.
X-1621A	Screen.
X-1622	Hose; oil feed.
X-1623	Oil tube; lower.
X-1624	Tube; oil feed, upper.
X-1625	Gasket; pump body.
X-3800A	Main shaft and gear assembly.
X-3801A	Gear and shaft assembly.
X-3802A	Drive gear assembly.
X-3806A	Cover and glass assembly.
X-3807A	Main body assembly.
X-3808A	Gear cover assembly.
X-3810A	Oil pump, complete less connecting hose and oil tube.
P-82	Screw; 8-32 x 3/8", fil. hd.
P-185	Pin; 1/8" x 3/8", groove type #1.
P-1000	Screw; 1/4-20 x 3/8", fil. hd.
P-1021	Screw; 6-32 x 1/4", french head.
P-1103	Washer.
P-1109	Clamp; oil hose.
P-1208	Screw; 6-32 x 7/8", fil. hd.
P-1255	Screw; 4-36 x 5/16", rd. hd.



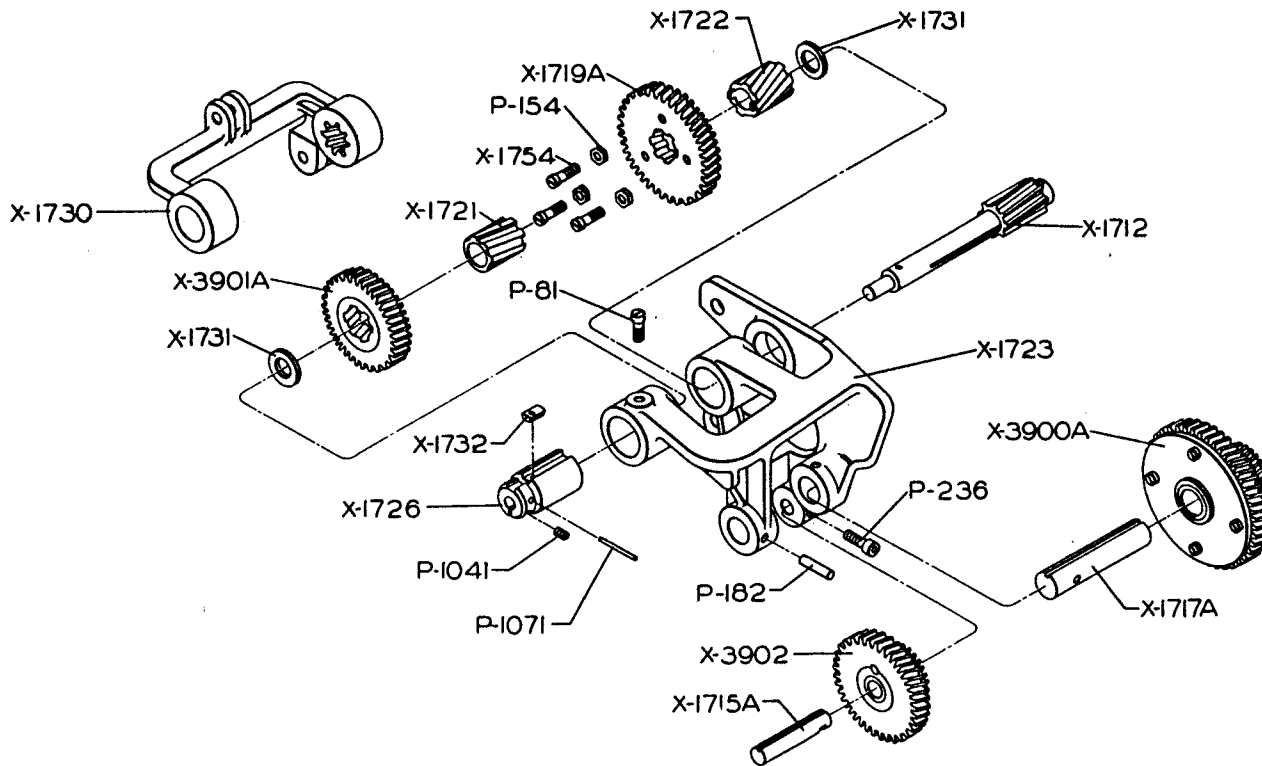

**Parts Illustration No. 10**  
**SHUTTER COMPENSATOR GEAR UNIT**

<i>Part No.</i>	<i>Description of Part</i>
X-1712	Shaft assembly; spline operating.
X-1715A	Shaft; idler gear.
X-1717A	Shaft; cluster gear.
X-1719A	Gear; spline shaft drive.
X-1721	Spline nut; inner.
X-1722	Spline nut; outer.
X-1723	Housing; main casting.
X-1726	Sleeve; spline retainer.
X-1730	Arm; framing compensator.
X-1731	Washer; spline shaft thrust.
X-1732	Key; sleeve guide, taper.
X-1754	Screw; thrust.
X-3900A	Drive gear assembly; intermediate.
X-3901A	Spline gear and shroud assembly.
X-3902	Idler gear cluster assembly.
X-3903B	Gear assembly complete; shutter compensator.
P-81	Screw; 8-32 x 1/2", fl. hd.
P-154	Nut; 10-32, hex.
P-182	Pin; 1/8" x 1/4" groove.
P-236	Screw; 10-24 x 1/4" set.
P-1041	Screw; 10-32 x 3/16", flat hd.
P-1071	Pin; 1/8" x 7/8", drive.

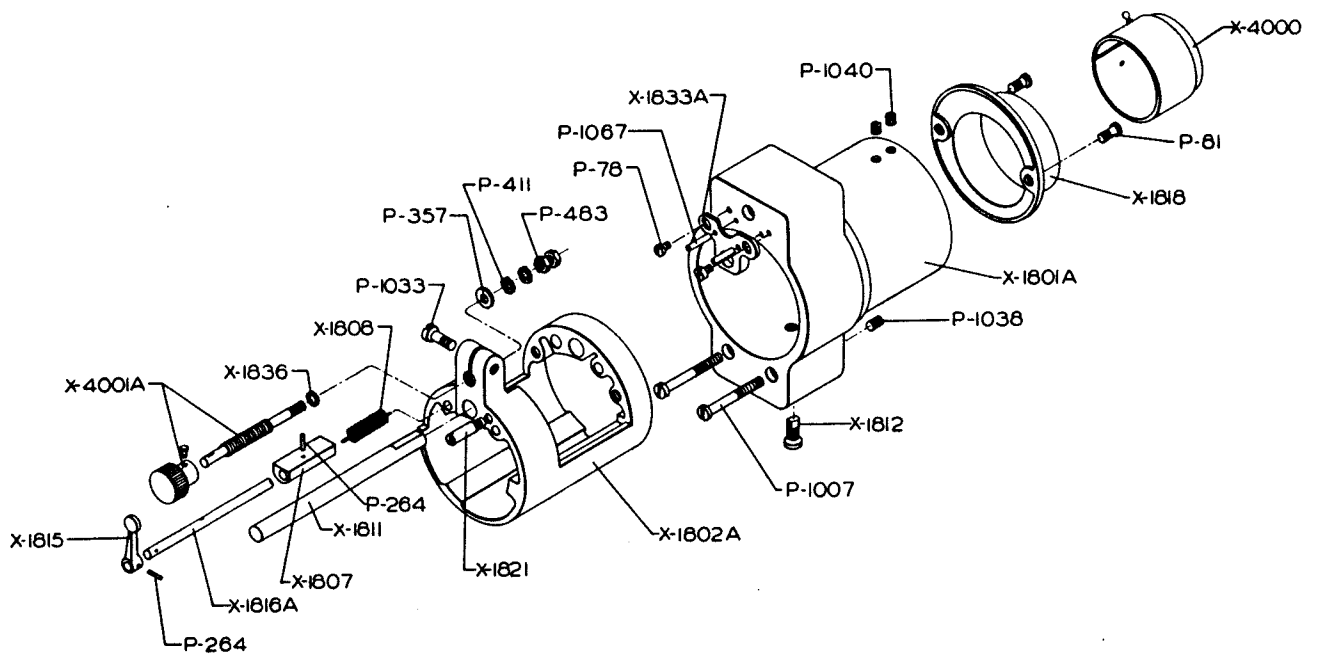

**Parts Illustration No. 11**  
**LENS MOUNTS**  
**(Standard Diameter)**

<i>Part No.</i>	<i>Description of Part</i>
X-1801A	Housing.
X-1802A	Sleeve.
X-1807	Cam; lens locking.
X-1808	Spring; cam tension.
X-1811	Shaft; inner sleeve guide.
X-1812	Pin; sleeve aligning.
X-1815	Lever; cam shaft.
X-1816A	Shaft; cam mounting.
X-1818	Collar; light shield.
X-1821	Pin; lens locating.
X-1833A	Plate; guide shaft adaptor.
X-1836	Washer; focusing shaft, thrust.
X-4000	Light shield.
X-4001A	Knob and shaft assembly; focusing.
X-4011	Lens mount assembly, complete less X-4000 light shield.
P-78	Screw; 8-32 x 1/4", fil. hd.
P-81	Screw; 8-32 x 1/2", fil. hd.
P-264	Pin; #1 groove.
P-357	Washer.
P-411	Washer.
P-483	Nut; 1/4-28, hex.
P-1007	Screw; 1/4-20 x 2", fil. hd.
P-1033	Screw; 10-24 x 3/4", fil. hd.
P-1038	Screw; 10-24 x 1/4", cup pt.
P-1040	Screw; 10-24 x 3/8", set.
P-1067	Pin; 1/8" x 3/8", groove.

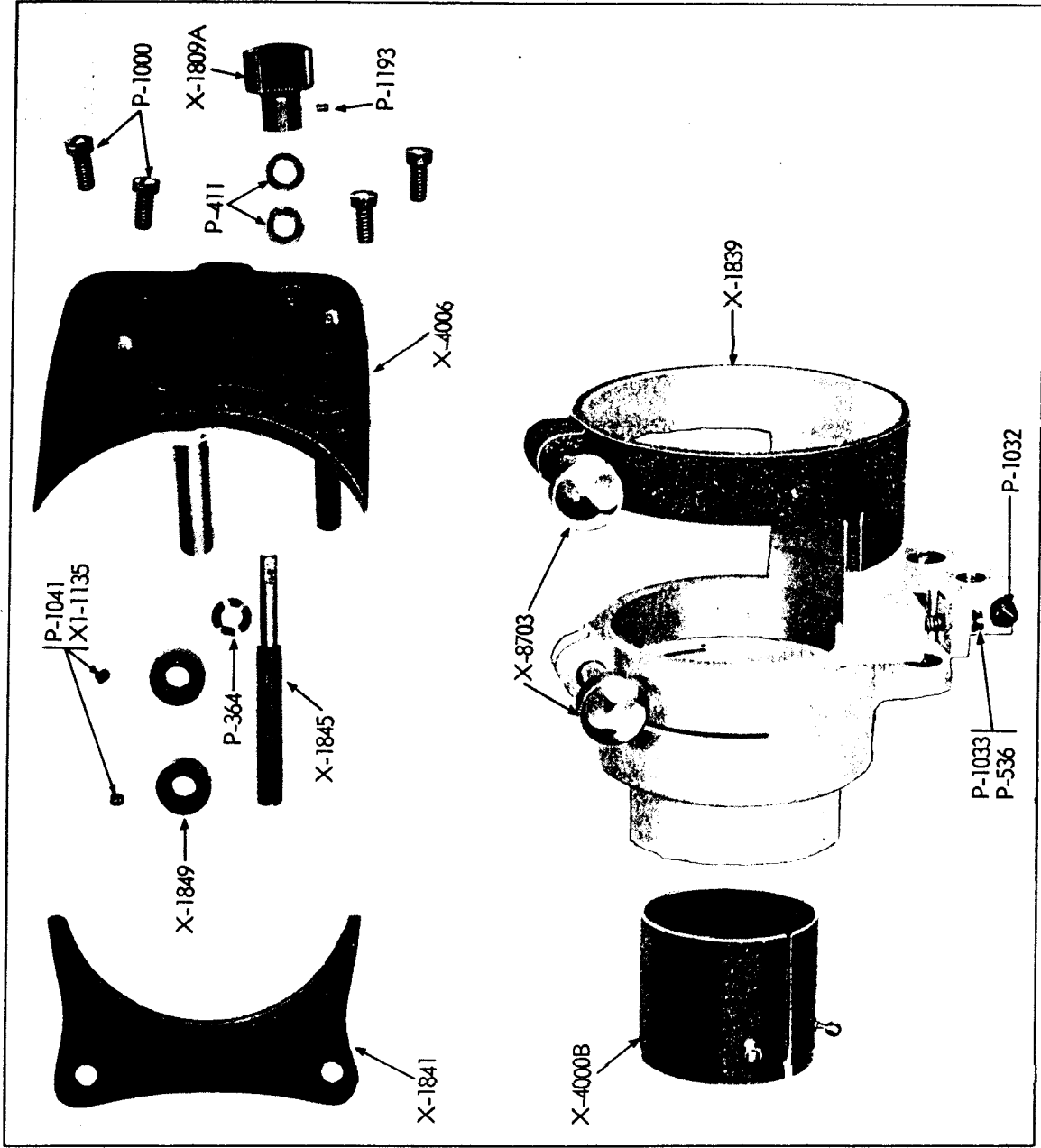

**Parts Illustration No. 12**  
**LENS MOUNT: 4" DIAMETER**

## LENS MOUNT: 4" DIAMETER

<i>Part No.</i>	<i>Description of Part</i>
X1-1135	Plug; lock screw.
X-1809A	Knob; lens focusing.
X-1839	Lens carrier.
X-1841	Light shield.
X-1845	Screw; focus adjusting.
X-1849	Nut; focus adjusting limit.
X-4000B	Split sleeve assembly.
X-4006	Support casting and shaft assembly.
X-4007	Lens mount assembly, complete (less X-4000B sleeve).
X-8703	Screw; lens clamping.
148053	Lens adaptor; 4" diameter to standard (not illustrated).
P-364	Washer.
P-411	Washer.
P-536	Lockwasher.
P-1000	Screw; 1/4-20 x 3/8", fil. hd.
P-1032	Screw; 10-24 x 1/2", fil. hd.
P-1033	Screw; 10-24 x 3/4", fil. hd.
P-1041	Screw; 10-32 x 3/16", soc. set.
P-1193	Screw; 6-40 x 1/8", soc. set.

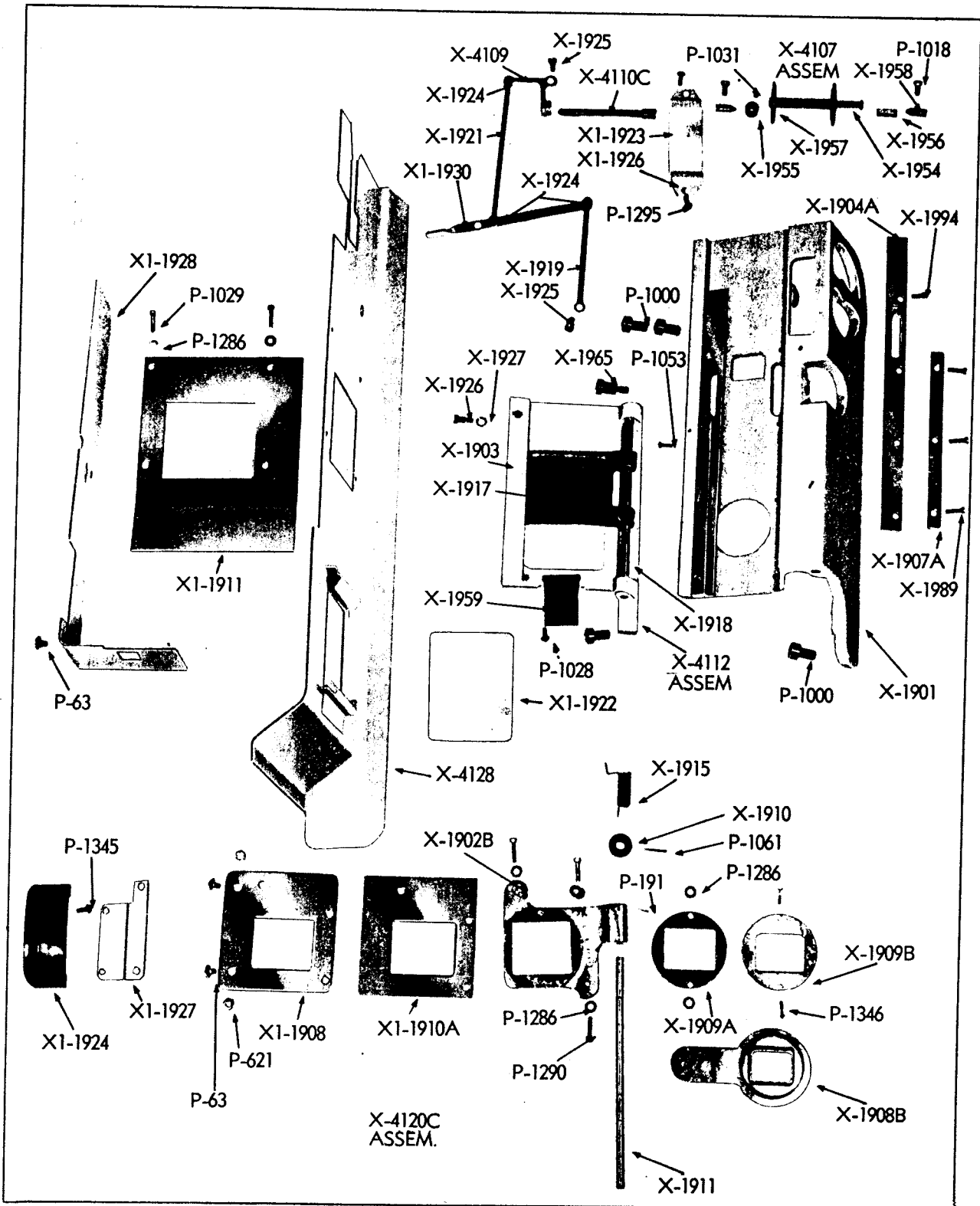

**Parts Illustration No. 13**  
**FILM TRAP UNIT**



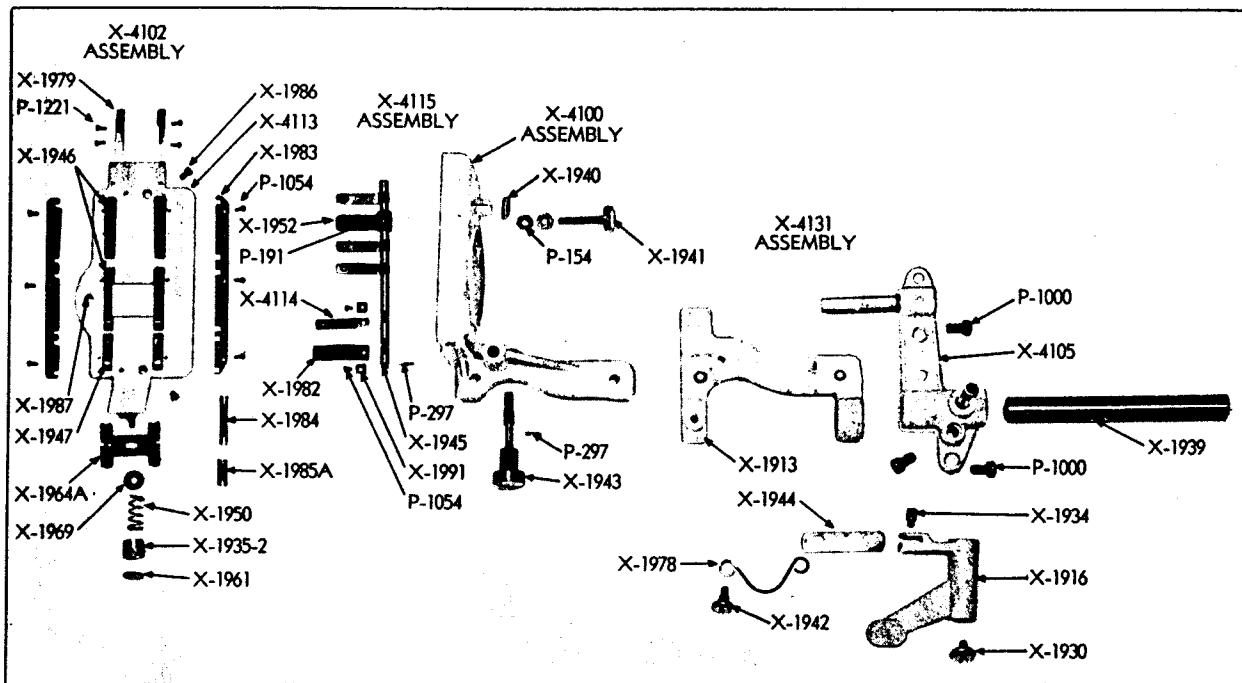

## Parts Illustration No. 14 FILM GATE UNIT

<i>Part No.</i>	<i>Description of Part</i>
X-1913	Base casting; film gate mounting.
X-1916	Lever; gate operating.
X-1930	Screw; gate operating lever, retaining.
X-1934	Screw; gate operating toggle link.
X-1935-2	Nut; intermittent sprocket tension pad.
X-1939	Shaft; gate guide.
X-1940	Nut; lock for pressure pad adjusting screw.
X-1941	Screw; pad spring adjusting screw.
X-1942	Screw; gate operating toggle link.
X-1943	Screw; gate mounting.
X-1944	Toggle link.
X-1945	Shaft; film pad tension adjusting.
X-1946	Pad; film pressure, large.
X-1947	Pad; film pressure, small.
X-1950	Spring; intermittent sprocket pad tension.
X-1952	Arm; pad adjusting.
X-1961	Nut; intermittent sprocket tension pad, lock.
X-1964A	Pad; intermittent sprocket tension.
X-1969	Seat; intermittent sprocket tension pad spring.
X-1978	Spring; toggle link pressure.
X-1979	Pad; film guide.
X-1982	Spring; pad tension.
*X-1983	Guide strip; film pressure pad.
X-1984	Spacer; film pressure pad, large.
X-1985A	Spacer; film pressure pad, small.
X-1986	Screw; 6-32, fil. hd.
X-1987	Screw; 6-32, fil. hd.
X-1991	Washer.
*X-4100	Gate casting assembly.

<i>Part No.</i>	<i>Description of Part</i>
*X-4102	Plate assembly; pressure pads and retainer.
*X-4103	Gate assembly, complete.
X-4105	Sub-plate assembly, complete with guide shaft and stud.
*X-4113	Shoe; film gate.
X-4114	Spring assembly.
*X-4115	Gate casting and pressure spring assembly.
X-4131	Sub-plate assembly, complete; gate mounting and operating.
P-154	Nut; 10-32, hex.
P-191	Pin; 1/16" x 3/8", groove.
P-297	Pin; 3/32" x 3/8", groove.
P-1000	Screw; 1/4-20 x 3/8", fil. hd.
P-1054	Screw; 2-56 x 1/8", fil. hd.
P-1221	Screw; 2-56 x 3/16", fil. hd.
*Not used where projectors are equipped with film cooling air jets. See below for similar parts used with air jet.	
X-4100A	Gate casting assembly.
X-4102A	Plate assembly; pressure pads and retainer.
X-4103A	Gate assembly, complete.
X-4113A	Shoe; film gate.
X-4115A	Gate casting and pressure springs assembly.
X-4123	Guide strip; film pad, upper inside.
X-4124	Guide strip; film pad, lower inside.
X-4125	Guide strip; film pad, upper outside.
X-4126	Guide strip; film pad, lower outside.

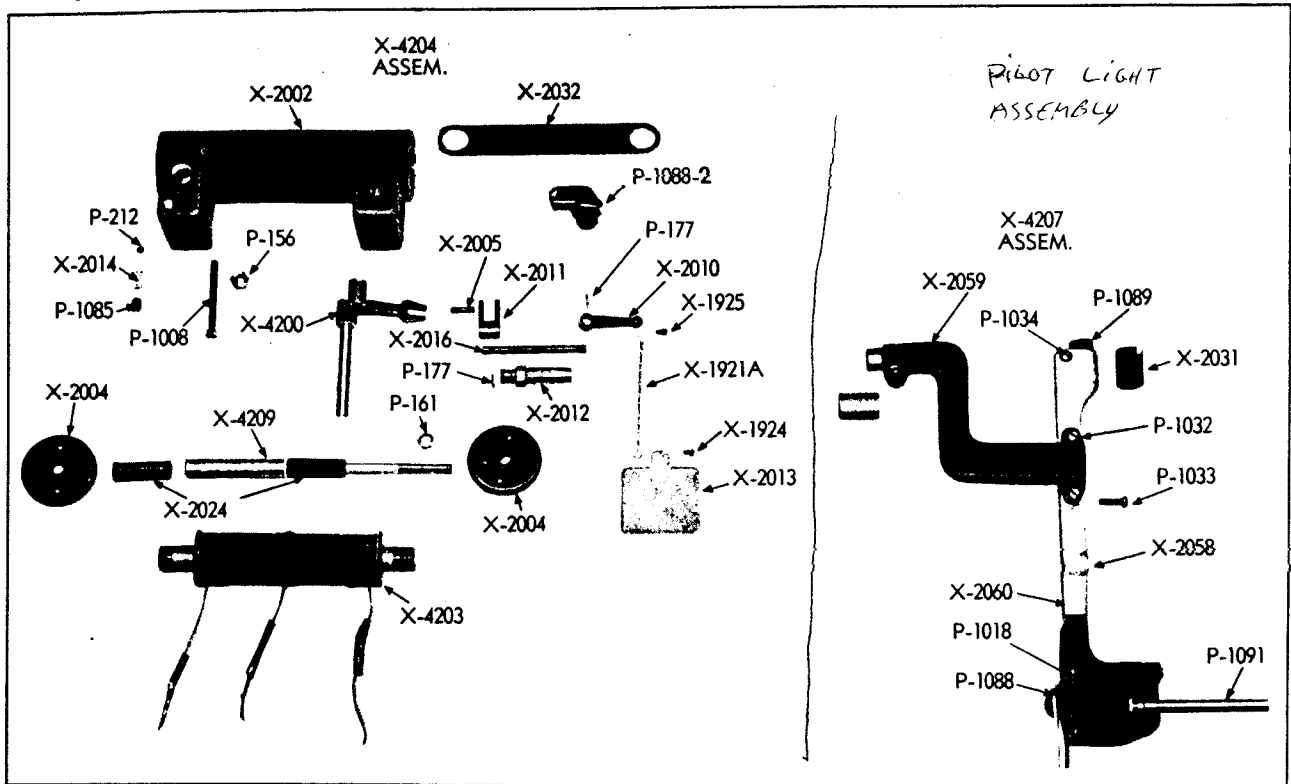

**Parts Illustration No. 15**

**PILOT LIGHT AND CHANGEOVER—ASSEMBLY**

Part No.	Description of Part
X-1921A	Link; shutter to crank connecting.
X-1924	Screw; shutter fastening.
*X-1925	Screw; link to crank fastening.
X-2002	Main housing; changeover.
X-2004	End plate; main housing, changeover.
X-2005	Pin; changeover operating.
X-2010	Crank; outer.
X-2011	Crank; inner.
X-2012	Bushing; main frame to swivel shaft (hex.).
X-2013	Shutter.
X-2014	Spring; guide shaft damping.
X-2016	Shaft; swivel.

Part No.	Description of Part
X-2024	Rubber bumper.
X-2031	Insulator; lamp socket.
X-2032	Bracket; cable support.
X-2058	Bracket; main.
X-2059	Bracket; rear.
X-2060	Plate; switch.
X-4200	Fork and shaft assembly; shutter actuating.
X-4201	Connecting linkage and shutter assembly.
X-4202	Changeover, complete, less X-4201 linkage.
X-4203	Field winding assembly.
X-4204	Changeover, complete with linkage.
X-4207	Pilot light bracket assembly, complete.

Part No.	Description of Part
X-4209	Armature and drive rod.
P-156	Nut; 1/4-20, hex.
P-161	Nut; 5/16-24, hex.
P-177	Pin; 3/32" x 1/2".
P-212	Ball.
P-1008	Screw; 1/4-20 x 2 1/4", fil. hd.
P-1018	Screw; 6-32 x 1/4", fil. hd.
P-1032	Screw; 10-24 x 1/2", fil. hd.
P-1033	Screw; 10-24 x 3/4", fil. hd.
P-1034	Screw; 10-24 x 3/8", fil. hd.
P-1085	Screw; headless.
P-1088-2	Angle connector.
P-1089	Socket; candelabra.
P-1091	Switch; pilot light.
P-1344	Lamp bulb (not illustrated).

**Parts Illustration No. 15A**

**MI-14313 CHANGEOVER UNIT—DETAIL PARTS**

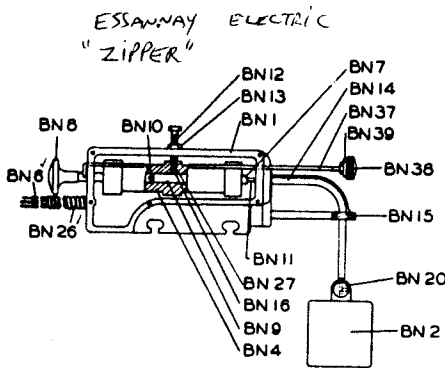

Part No.	Description of Part
BN-1	Main casting.
BN-2	Shutter.
BN4-60	60 cycle coil.
BN4-50	50 cycle coil.
BN4-25	25 cycle coil.
BN-5	D. C. coil.
BN-6	Three wire cable in conduit.
BN-7	Armature complete with flexible shaft and knob.
BN-8	Armature knob.
BN-9	Steel armature section.
BN-10	Brass armature section.
BN-11	Flexible shaft with connector.
BN-12	Armature speed adjustment screw.
BN-13	Armature speed adjustment screw nut.

Part No.	Description of Part
BN-14	Flexible shaft tube.
BN-15	Flexible shaft tube clamp.
BN-16	Armature speed adjustment screw ball.
BN-19	Mounting bracket.
BN-19a	Inside bracket.
BN-20	Shutter pivot with set screws.
BN-26	Conduit only.
BN-27	Armature speed adjustment screw spring.
BN-36	Thermostat.
BN-37	Right hand, hand rod.
BN-38	Right hand, hand rod knob.
BN-39	Nut; hand rod knob locking.
* For replacement order X-1933 screw and P-621 nut.	



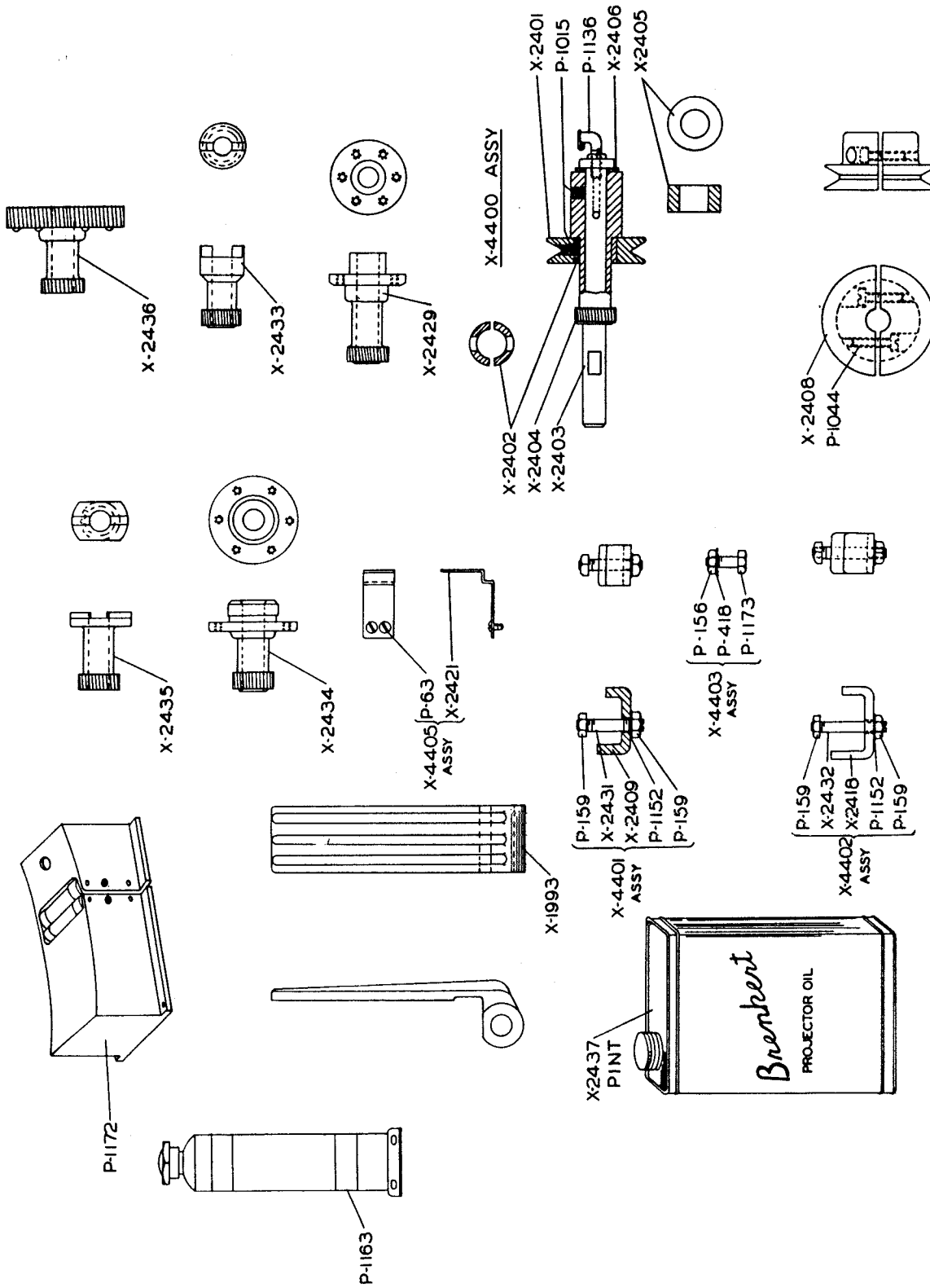

**Parts Illustration No. 16**  
**MISCELLANEOUS ACCESSORIES**

## MISCELLANEOUS ACCESSORIES

### 17-TOOTH DRIVE GEARS FOR RCA AND ERPI SOUNDHEADS

<i>Part No.</i>	<i>Description of Part</i>
X-2404	WE-209, WE-211 soundheads. (Also available from RCA as stock No. 29368.)
X-2434	RCA soundheads PS-22, PS-24, MI-1040, MI-1050, MI-9001, MI-9030, MI-9050. (Also available from RCA as stock No. 28666.)
X-2429	WE-7400 soundhead.
X-2433	WE Universal soundhead. (Also available from RCA as stock No. 29369.)
X-2435	WE-208A soundhead. (Also available from RCA as stock No. 29371.)
X-2436	WE-206A soundhead. (Also available from RCA as stock No. 29370.)

### PULLEYS REQUIRED ON WE-206A, 208A SOUNDHEADS FOR DRIVING TAKEUP REEL WHEN USED WITH BRENKERT PROJECTORS

<i>Part No.</i>	<i>Description of Part</i>
X-2408	Split pulley.
P-1044	Clamp screw.
X-4406	Pulleys and screws complete, includes parts X-2408 and P-1044 assembled.

### DRIVE GEAR AND TAKEUP PULLEY FOR WE-209/211 SOUNDHEADS

<i>Part No.</i>	<i>Description of Part</i>
X-2401	Pulley; takeup reel drive.
X-2402	Pulley bushing.
X-2403	Shaft for drive gear.
X-2404	17-tooth gear with long hub. (Also available from RCA as stock No. 29368.)
X-2405	Spacing collar for lower magazine shaft.
X-2406	Thrust washer.
P-1015	Set screw, headless $\frac{5}{16} \times 20$ .
P-1136	Oil cup.
X-4400	Drive gear, shaft, pulley, and spacer assembly required on WE-209, WE-211 soundheads when used with Brenkert projectors; includes all parts listed above.

### THIRD HOLE MOUNTING CLAMPS

#### RCA SOUNDHEADS PS-24

<i>Part No.</i>	<i>Description of Part</i>
X-2409	Clamp.
Z-2431	Bolt.
P-159	Nut.
P-1152	Lockwasher.
X-4401	Clamp and bolt assembly for third point mounting attachment for RCA PS-24 soundhead.

#### RCA SOUNDHEADS MI-1040, MI-1050

<i>Part No.</i>	<i>Description of Part</i>
X-2418	Clamp.
X-2432	Bolt.
P-159	Nut.
P-1152	Lockwasher.
X-4402	Clamp and bolt assembly for third point mounting attachment for above types of soundheads.

#### RCA SOUNDHEADS MI-9030/9050

<i>Part No.</i>	<i>Description of Part</i>
P-156	Nut.
P-418	Lockwasher.
P-1173	Bolt; $\frac{1}{4} \times \frac{3}{4}$ .
X-4403	Bolt and nut for third point mounting attachment for RCA MI-9030/9050 types of soundheads.

### TOOLS AND OPERATING SUPPLIES

<i>Part No.</i>	<i>Description of Part</i>
X-1993	Tool for aligning film guide strips of trap unit.
X-2437	Lubricating oil for Brenkert projectors (1 pint).
P-1163	Sealing compound for sealing assemblies to main frame.

### MASSACHUSETTS REQUIREMENTS

<i>Part No.</i>	<i>Description of Part</i>
P-63	Screw.
P-1172	Film valve assembly.
X-2421	Cover for slot of film valve.
X-4405	Cover for slot of film valve and attaching screws; includes parts X-2421, P-63.

\* For Replacement order X-1933 and P-621.