

Film-Tech

The information contained in this Adobe Acrobat pdf file is provided at your own risk and good judgment.

These manuals are designed to facilitate the exchange of information related to cinema projection and film handling, with no warranties nor obligations from the authors, for qualified field service engineers.

If you are not a qualified technician, please make no adjustments to anything you may read about in these Adobe manual downloads.

www.film-tech.com

Century

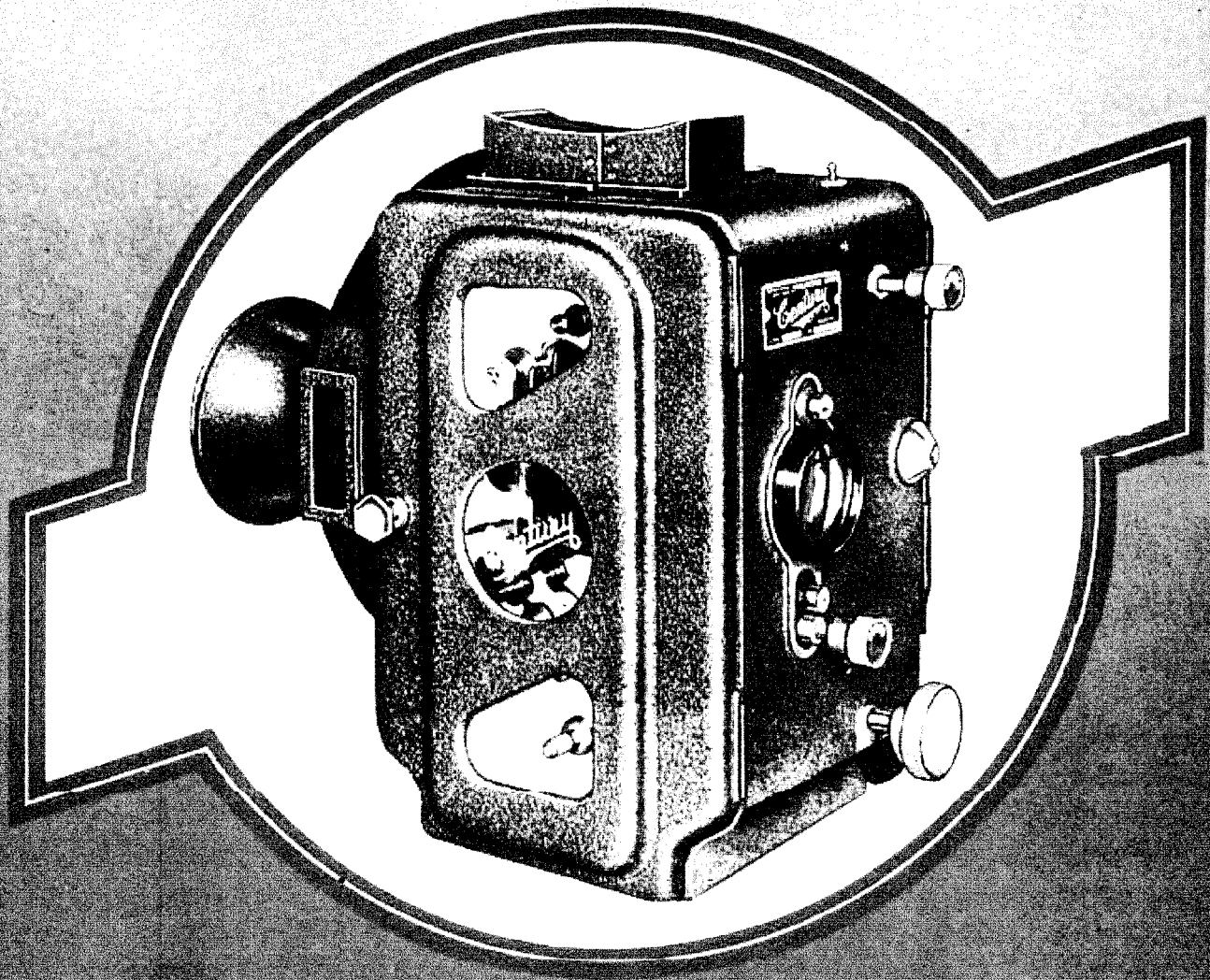

INSTRUCTIONS

CENTURY PROJECTOR MECHANISM

MODEL C

THE MODERN PROJECTOR

INSTRUCTIONS
 ASSEMBLY AND INSTALLATION
 OF
 CENTURY PROJECTOR MECHANISM
 MODEL-C

PAGE

INDEX

General	1
Installation	2
Mounting	2
Operating Instructions	3
The Gate.	3
Pad Rollers	4
Installing the Lens	5
Timing the Shutters	5
Oil the Projectors	6
Threading the Projector	7
Framing	7
Maintenance	7
Removing the Intermittent	8
Installing a new Intermittent Movement	8
Changing the Intermittent Sprocket.	9
Adjustment of the Cam Shaft Thrust Bearing	9
To Assemble the Intermittent.	10
Removing and Adjusting the Film Trap.	11
Replace or Reverse the Film Trap Shoes or Studio Guides	11
Replacing the Gate Knob	12
Replace the Gate Knob Spring	12
Replacing the Film Gate Pads	12
Replace the Pilot Light	13
Removing the Shutter Guards	13
Replace the Upper or Lower Sprocket	13
Take Out the Aperture Plate	13
Setting the Height of the Fire Shutter.	13
Clean the Threading Reflector	14
Removing the Upper or Lower Pad Rollers	14
Remove the Upper Pad Roller Arm Complete.	14
Replace the Lower Pad Roller Arm Complete	14
Replace the Intermittent Pad Shoe Assembly Complete	14
Removing the Shutter Shaft Complete	15
Removing the Vertical Shaft Complete	15
Removing the Main Drive Shaft and Gear.	15
Removing the Film Gate Support and Lens Holder.	16

DRAWING INDEX

Figure #1 - Operating Side.	17
Figure #2 - Driving Side.	18
Figure #3 - Intermittent Movement	19
Figure #4 - Intermittent Movement Adjustments	19

CENTURY PROJECTOR CORPORATION
 729 Seventh Avenue
 New York, N.Y.

INSTRUCTIONS
ASSEMBLY AND INSTALLATION
OF
CENTURY PROJECTOR MECHANISM
MODEL-C

The Century Projector has been designed and built by men of experience, after years of study and research, to meet with the modern demands for perfect projection in theatres. The highest degree of accuracy in manufacture and design is maintained so as to give the industry a projector mechanism of outstanding merit.

We would suggest that a careful study be made of this mechanism to become familiar with all the modern features and realize all the benefits of performance and durability which has been designed into it.

"NOTHING ROLLS LIKE A BALL." This is the reason why ball bearings have been adopted in the CENTURY Projector mechanism. These ball bearings are sealed against dirt and NEVER require lubrication of any kind. They are grease-packed at the factory with high temperature grease and will operate continuously at temperatures as high as 180 degrees without damage.

There are two slow speed shafts; (the feed and take-up sprocket shafts) which have been designed with oil-less type bearings. In shafts such as these ball bearings are not used because of the slow speed of rotation. The bearings used in the CENTURY Projector should be called OIL-PLUS instead of oil-less because they are actually porous and the pores have been filled with the highest quality lubricating oil. This oil is held within the bearing until needed and is automatically released in the required amounts. In addition, oil reservoirs are provided on each bearing which may supply the bearing with oil. It is therefore not necessary to channel the shafts, as all surfaces of the bearing are supplied with a constant supply of clean filtered oil at all times.

The intermittent movement is an outstanding example of precision workmanship. It is direct drive having no gears inside the case. Four bearings have been provided. Two of the bearings are on the starwheel shaft and two on the cam shaft. These four bearings assure accurate alignment of the working parts. All the bearings are supplied with oil thru scientifically designed oil holes drilled thru the case and cover of the intermittent. The outside bearings are the same OIL-LESS type which are used on the sprocket shafts. With the intermittent filled to the center of the gauge glass, from the operating side, it will continue to properly lubricate all bearings automatically.

The intermittent is removed from the operating side of the projector so that damage to the sprocket is minimized and the removal of gears unnecessary.

Other than filling the intermittent with oil and a drop of oil on each gear once a day, the whole projector may be considered OIL-LESS and should continue to operate satisfactorily for long periods with minimum attention.

The shutter shaft and vertical shaft, including their respective gears, collars, bearings, etc., are removable from the projector as complete units. These shafts may be replaced in the booth without the use of alignment tools or reamers.

The main frame, sides, top and bottom of the CENTURY Projector are of cast iron and cast in one piece. Thus the main frame is rigidly supported on all sides. All the working parts of the projector are supported on this main frame against carefully machined surfaces assuring accurate alignment of all shafts and maintenance of optical centers. This is one of the reasons why this projector produces steadier pictures.

The pressure pads at the intermittent sprocket are self aligning and are assembled as a unit on the intermittent movement. The gate can therefore be opened and closed without releasing the film from the intermittent sprocket. This feature makes it convenient to check the placement of the film between the trap shoes and at the aperture.

INSTALLATION

Unpacking the Projector

The excelsior should be taken out of the case and the inside wooden strip removed by drawing out the four nails holding same. Then the mechanism can easily be taken out of the case. The packing material should be removed from the projector very carefully. Care must be taken to remove every trace of packing material or other foreign matter which may have crept into the mechanism during shipment.

MOUNTING:

The CENTURY Projector is adaptable to all types of sound heads.

In addition to the two tapped holes usually provided for holding a projector, there are four other holes located in the base which may be used for additional support. Sound heads designed for this additional support will have corresponding holes.

In older types of sound heads it may be possible to re-drill the sound head and add spacers, thus taking advantage of greater stability between the sound head and the projector.

The height of the optical center above the mounting surface of the sound head is standard as well as the position of the aperture with respect to the mounting holes. This projector can therefore replace the Simplex type projectors with no adjustments necessary in lamphouse or sound head.

Referring to Fig. 2, which shows the construction of the main drive shaft and gear. No. 1 is the main drive shaft. No. 2 is the main drive gear. No. 3 is the shaft and coupling device to the sound head. No. 4 is the set screws clamping together the main shaft, main drive gear and coupling shaft from the sound head. The main drive shaft is designed for a 7/16 inch coupling shaft. The end of the main drive shaft is provided for coupling to a pinion drive such as is used on Simplex type projectors. When used with this type of drive the set screws No. 5 clamps the pulley No. 6 around the end of the split main drive shaft. This in turn clamps the outside of the pinion as well as the set screws clamping between the teeth of the pinion. The whole assembly including the sound head coupling rotates on the ball bearings No. 7.

OPERATING INSTRUCTIONS:

THE GATE:

The large nickel plated knob #1-Fig. 1, in the center of the projector on the operating side opens and closes the gate. To open the gate, give it a half turn to the right. The gate will open and the knob will remain in that position automatically locking the gate in open position.

To close the gate, push the center of the knob with the thumb or hand and the gate will close automatically. In the closed position the gate is locked and cannot be opened except by turning the knob as directed.

The gate is mounted at the rear of the lens holder on a sliding tube. This type of construction assures accurate alignment of the gate with the film trap and prevents displacement of the gate due to accidental bending.

To remove the gate for inspection; open the gate as described above and loosen the holding screw #2-Fig.1. The gate can now be pulled straight toward the trap. This will disengage the two supporting studs which hold the gate in the lens tube.

The gate pads are long and heavy and are designed to give uniform pressure against the film over their entire surface.

The lever design assures that exactly equal pressure is applied to both sides of the film which has been found so necessary in the elimination of picture jump and weave. The combination of the tension springs, levers and pads has been designed so that there is minimum disturbance of the pads as slices go thru the projector.

The tension of the pads is adjustable over a wide range thru tension springs #3 & #4 - Fig.1. After a little experimenting, the best operating pressure will be found for any condition of film. It is suggested that until these optimum values are found that the adjustment nuts be in about mid position. A safety feature on the adjustment will be found in the stops provided, so that the tension adjustment nuts cannot be tightened so far as to lock the film in the gate. It is desirable to operate with as little tension as possible on both the upper and lower pads and still maintain a steady picture. The lighter the tension, the less wear on sprockets, shoes, pads and etc.

PAD ROLLERS:

The upper and lower pad roller arms are opened by pushing the roller knobs toward the rear of the projector. The pressure pads on the intermittent sprocket are opened by pushing the knob downward.

The upper and lower pad rollers in open position provide for automatically setting the loops above and below the gate. The lower pad roller also provides a means of measuring the correct distance on the film between the picture aperture and the sound aperture, thus assuring exact synchronization of sound and picture.

Although there are no tension springs showing on the pad rollers each has a scientifically designed tension device built into the pad roller arm providing just the right amount of tension for optimum performance. Each pad roller arm has a positive stop in closed position, which prevents undue mutilation of the film. These stops are adjustable.

The upper and lower pad rollers should be adjusted so that there is a clearance of two thicknesses of film between the pad roller and the sprocket. This clearance is adjusted by means of the stop screw #5, shown in Figure 1.

The intermittent sprocket pad assembly is adjusted by loosening the set screw #7 Figure 3 and turning the shaft. The pad assembly should be turned so that the pads just make contact with the intermittent sprocket with little or no pressure being applied. When film is threaded thru the intermittent it will depress the pad shoes by an amount corresponding to the thickness of the film. This will be the correct amount of tension for best operation.

INSTALLING THE LENS:

The lens holder is designed for "half size" lenses including the latest F2 lens recently developed. (No change in the shutters has to be made for this high speed operation.) With the proper adapters the holder will fit any projection lens.

Care should be taken that the front of the lens is towards the screen, otherwise the quality of the picture will not be satisfactory.

The lens focusing knob should be turned so that the lens clamp is in the center of its full length of travel. Insert the lens into the holder and clamp it lightly in place with lens clamp knob #6-Fig.1. If the focus is not good, when the picture is projected, the lens may be shifted back and forth until a finer focus is obtained. The lens clamp is tightened and the final accurate focusing done with the focusing knob which extends thru the projector case toward the front.

TIMING THE SHUTTERS:

Each CENTURY Projector has been set up and run in the factory so that when it is received, the shutters should be in time. However, it is well to check this point as follows:

The spot sight aperture is located in the fixed shutter guard on the operating side of the projector. The red glass in the aperture is removable by pressing it in with the thumb and pushing it upward. After the red glass has been removed you will notice an indicator across the aperture which is used for timing the shutters.

When the projector is turned slowly by hand you will observe that the shutter blade has been notched at the edge #7 - Fig. 1. This is the blade which is used in timing the shutter with the intermittent sprocket.

Turn the projector slowly by hand and observe the intermittent sprocket. When the sprocket has advanced two teeth from its stationary position, stop the projector. This alignment must be done very accurately. If the shutter is in time with the intermittent the notch on the shutter blade will line up exactly with the indicator across the spot sight aperture. If this condition cannot be obtained, then the shutter should be loosened from the shutter shaft and rotated until this condition is obtained and the shutter locked in position.

Before changing any of the above settings be sure that the timing of the shutter cannot be corrected by adjusting the shutter timing knob on the front of the mechanism. If the shutters are moved on their shafts be sure that the shutter timing adjustment is set in the center of its full length of travel before locking them to their shafts.

After timing the shutter as explained above, the final adjustment may be made with the projector running. Any travel ghost which may be present can be eliminated by adjusting the shutter adjustment knob.

An easy and very satisfactory way of checking the shutter timing is to proceed as follows:

You will note that the hub of the flywheel on the intermittent movement is slotted. Turn the projector until this slot is parallel with the shutter shaft, at the same time the intermittent sprocket is moving. In this position the notch in the shutter blade should be directly opposite the wire indicator which is across the spot sight aperture.

OIL THE PROJECTOR:

DO NOT OIL THE BALL BEARINGS:

Place a drop of oil on each gear daily. An excessive amount of oil does no more good than just enough. Any excess of oil will be thrown off the gears and will eventually make the inside of the projector look very dirty if it is not cleaned away.

Put a drop of oil into the oil cups on the upper and lower sprocket shafts.

The intermittent should be filled with oil thru the oil cup #8-Fig. 1, on the operating side of the projector, so that the oil gauge will show about half full. If by chance too much oil is put into the intermittent, it will run out of the vent hole on the outer bearing near the flywheel. Otherwise no damage will result in running the intermittent too full of oil. To remove any excess oil from inside the intermittent, the bottom screw shown in #1-Fig. 3, can be removed and as much oil as is necessary drained out. A clean cloth should be placed under this screw, before it is removed, to catch the oil and prevent it from running down into the sound head. Replace the screw and refill the case if necessary.

It is better not to add oil to the intermittent while the projector is running unless this seems desirable in case of emergency. The intermittent cam acts as an oil pump so that while it is running the oil pumps from the bottom of the case and supplies the CAM, STARWHEEL and BEARINGS with a constant supply of fresh oil. There may therefore be no indication of oil level in the gauge glass while the projector is running.

Oil the projector before running. Oil can snouts have a habit of getting caught in the gears if this work is done with the projector running.

THE FOLLOWING OILING ROUTINE IS SUGGESTED

Once each day -- a drop of oil on each gear.

Once each week-- check the oil level in the intermittent and put a drop or two of oil in the oil cups on the sprocket shafts.

THREADING THE PROJECTOR:

Open the gate, the upper and lower pad roller arms and the intermittent sprocket pad. Thread the film thru the fire trap in the upper magazine; under the upper sprocket; over the upper pad roller; thru the gate; under the intermittent sprocket; around the lower pad roller; over the lower sprocket and down to the sound head as shown in Fig. 1.

Light the framing lamp by operating the pilot light switch on the top of the projector case. Place the film in the gate with the intermittent sprocket engaged with the film so that it is in frame. Close the intermittent pad assembly. Close the gate. The film may be observed in the gate thru the observation hole provided in the gate holder tube.

The film is now engaged with the upper sprocket with a tight loop. Close the upper pad roller.

A check of the proper framing may be made by observing the sprocket holes below the film trap shoes. With a frame line at the bottom of the trap shoes, the upper side of the sprocket hole of the upper hole next to the frame line will come exactly even with the bottom of the trap shoe.

The film is now engaged with the lower sprocket with a tight loop. Close the lower pad roller.

With the film properly threaded thru the sound head to the lower magazine, the projector is ready to run.

FRAMING:

The framing of the picture on the screen may be changed by turning the framing knob on the front of the projector. The degree of clamping of the framing shaft may be changed by tightening or loosening the screw #21-Fig.2, on the framing clamp.

MAINTENANCE:

Other than keeping the projector properly oiled and cleaned, the maintenance of this CENTURY Projector should be minimum. There are several new and important improvements which should be noted, and advantage taken of them in the regular maintenance routine. Do not use Benzine or other cleaning fluids on the gears or shafts where excess amounts might enter the sealed ball bearings.

Practically all the operating units of the machine are easily removed and replaced. Most of the removable parts are located by dowel pins making the replacement comparatively easy.

Included are the following: The main drive shaft; the vertical shaft assembly complete; the shutter shaft complete; the film trap; the film gate; the upper and lower sprocket shafts, the upper and lower pad roller arms, the intermittent movement and the intermittent sprocket pad assembly.

Spare parts including complete assemblies of the above may be kept in the booth at all times and replacement quickly made in case of an emergency.

INSTRUCTIONS COVERING THE REMOVAL AND REPLACEMENT OF PARTS ON THE PROJECTOR:

REMOVING THE INTERMITTENT:

Take off the flywheel of the intermittent on the driving side of the projector by taking out the screw #20 - Fig. 2, which holds it and slip it off the cam shaft. Frame the intermittent carriage all the way in its down position. Remove the film gate. On the operating side of the projector, loosen the four screws holding the intermittent shown in #9 - Fig. 1. Turn the intermittent about an eighth turn in a clock-wise direction until the cut-outs in the intermittent cover are even with the holding screws. Pull the intermittent straight out of its carriage. Care should be taken not to hit the intermittent sprocket against anything which would damage the teeth.

INSTALLING A NEW CENTURY INTERMITTENT MOVEMENT:

Refer to Figure 4.

Set the shutter adjustment mid-way of its full travel, open the film gate to maximum stop. Move the intermittent carriage to its down position. Remove the flywheel of the new movement by taking out the holding screw and slipping it off the cam shaft. Loosen the intermittent stop screw (A).

Remove the red glass from the spot sight aperture. Rotate the mechanism by hand until the notch in the shutter blade is even with the bottom of the spot sight aperture.

Take the movement in your hands and rotate the gear on the cam shaft until the sprocket advances exactly two teeth. Be careful not to move the gear from this position.

Insert intermittent with cut outs (B) matching the locking screws (C) and lower end of film trap shoe (D). Turn the movement counter clockwise so that the intermittent Gear (2) meshes with its driving Gear (1) on the vertical shaft. Continue turning the movement until these two gears press lightly together with no backlash or play. Tighten any two opposite screws (C). Push the stop plate (E) tight against the stop (F) and tighten

screw (A). Now loosen the two (C) screws which were previously tightened and turn the movement clockwise until there is a space of $3/64$ (.046) of an inch between stop plate (E) and its stop (F). Hold the movement in this position or insert a $3/64$ inch spacer between stop plate (E) and stop (F) and tighten all four screws. (Note: A dime is approximately $3/64$ " thick.)

Loosen screws (A), push stop plate (E) tight against its stop (F) and tighten screw (A). Replace the flywheel on the cam shaft. A slight amount of backlash should now be present between Gears 2 and 1. Put oil in movement (M), check oil level at red line (O), before running. Check the timing of the shutters. Loosen shutter hub screws (I) so that shutters turn on shaft. Turn the projector by hand so that flywheel screw (H) is in line with the vertical shaft, line up notches (K) with wire (L) being careful not to shift projector gears, tighten screws (I), replace guard.

If slight travel ghost is present with projection of picture, it may be removed by turning shutter adjusting knob right or left.

CHANGING THE INTERMITTENT SPROCKET:

Remove the intermittent movement from the projector in accordance with the instructions given above. Drain the oil from the case by removing the oil drain screw shown in #1 - Fig. 3. Do not attempt to save this oil to be replaced in the movement. Always use clean, fresh oil. Remove the other four screws in the cover. Under the heads of all these screws you will find copper washers. Save these washers for re-assembly.

Loosen the two set screws #2-Fig. 3. Hold the case of the intermittent with one hand and the cover with the other hand and carefully pull them apart. Extreme care must be used in this operation in order that the STAR or CAM should not be damaged.

Push the two taper pins out of the hub of the sprocket, using a tool made for this purpose. If such a tool is not available, place the hub of the sprocket into a "V" block and very lightly tap out the two pins. These pins should never be removed except in one of the two ways indicated. Loosen the two screws in the collar on the outside end of the starwheel shaft and remove the collar. The starwheel and shaft can now be pulled out allowing the sprocket to be removed.

All the above operations should be carried out with extreme care. It is not necessary to use force in removing any of the units. If any difficulty is encountered, the complete movement should be returned for repairs.

ADJUSTMENT OF THE CAM SHAFT THRUST BEARING:

While the intermittent is disassembled, the end play of the CAM SHAFT should be checked and if found to be excessive it

should be adjusted. You will note that at the end of the CAM SHAFT there is a thrust bearing #5-Fig.3. By loosening the locking screw #4-Fig.3, the thrust bearing may be tightened or loosened by screwing it in or out. It should be adjusted so there is no perceptible end play in the CAM SHAFT and yet not tight enough to cause the CAM SHAFT to drag or bind.

Tighten the locking screw #4. Fig. 3.

The end play of the cam shaft may also be adjusted after the movement is assembled by removing the large plug screw in the center of the movement case. This will expose the end of the thrust bearing #5-Fig.3. A screw driver slot is provided in the end of this bearing so that it may be tightened or loosened. The same adjustment will apply as described above.

TO ASSEMBLE THE INTERMITTENT:

Insert the starwheel shaft into the bearings of the cover and make sure that it turns smoothly in its operating position. Pull the shaft almost out of the inner bearing and place the sprocket in position. Push the shaft all the way thru until it is in place with the holes in the shaft lined up with the holes in the sprocket. These are tapered holes so care should be taken that the tapers line up properly.

Push the two pins into place with the tool which was used to remove them, but not too tight. Replace the collar at the outer end of the shaft. Hold the starwheel with the thumb and the collar with the first or second finger and gently squeeze the two together. Tighten the two set screws in the collar. The starwheel and sprocket should rotate without binding and with no drag; at the same time there should be no perceptible end play in the shaft.

Replace the gasket.

Hold the case of the intermittent in the right hand with the CAM PIN in the down position (out of engagement with the starwheel) and hold the cover in the left hand with the starwheel rotated so that the radius of the star will match the radius of the CAM. when the two are put together. Carefully place the locating hole over the locating pin #6-Fig. 3. Move the cover so that the starwheel radius is slightly above the Cam Ring and push the cover and case together slowly, all the way. Then gently lower the cover until the star and cam meet. Replace all the holding screws. If the job has been done correctly, it is now possible to rotate the cam by the flywheel and advance the intermittent sprocket.

The case should now be filled to the proper operating level with oil by means of the oil cup provided for that purpose in the end of the starwheel outer bearing. Revolve the flywheel a number of times making sure that there are no binds and that the cam pin

is moving in and out of the starwheel satisfactorily. Do not force the Cam Pin into the Star Wheel by turning the flywheel. It is well to check the intermittent sprocket for any looseness when the sprocket and starwheel are in locked position. If any play is found, it can be adjusted by lightly loosening the screws around the cover and tightening or loosening the two set screws #2-Fig.3. Loosening the upper screw and tightening the lower one a fraction of a turn will tighten the starwheel against the CAM. This operation is a most delicate one and should never be performed with the projector running.

As soon as everything has been checked and the intermittent is in good running condition, it may be replaced in the projector. It has been found desirable to "run-in" the intermittent for a little while after changing the sprocket or starwheel by mounting the intermittent in a holder and running it at normal speed with a belt drive to the flywheel.

REMOVING AND ADJUSTING THE FILM TRAP:

Remove the heat shield by taking out the two screws just above and in back of the film trap. Take out the three screws holding the film trap. One of these will be exposed when the heat shield is removed. The film trap can now be removed by pulling it straight out.

Note that there are two guiding pins which keep the film trap accurately in line and at right angles to the optical center line. These pins hold the trap in vertical alignment when it is moved backward and forward for adjusting the film trap shoes in the proper position to the intermittent sprocket. The film trap is set at the factory and will not require adjustment unless the trap is removed to renew the shoes or the studio guides.

If new shoes are installed, they should be lined up with the sprocket as follows: Loosen the two screws holding the film trap. Make two wraps of film around the intermittent sprocket. Place a straight edge against the face of the shoes and let it extend down to the sprocket. The film trap should now be moved forward or backward until the straight edge comes into contact with the film which is around the sprocket. Tighten the film trap holding screws.

REPLACE OR REVERSE THE FILM TRAP SHOES OR STUDIO GUIDES:

Remove the film trap. Take out the four screws holding the studio guides. This will allow the studio guides and the film trap shoes to be removed. The film trap shoes may be reversed from right to left giving double life.

The studio guides may be reversed from right to left as well as turning them over from inside to outside. This provides for four times normal wear.

After the changes have been made, the film trap should be replaced and adjusted as instructed under "REMOVING AND ADJUSTING THE FILM TRAP".

REPLACING THE GATE KNOB:

Loosen the two set screws, one on top and one below the knob assembly, on the lens tube and gate mounting. Pull the gate knob straight out.

The new gate knob should be turned in its hub, to the right, until it locks in the first stop. The gate tube should be moved to its "gate open" position. The knob assembly should then be inserted into its holder, with the oil hole up, so that the gate tube and the recesses in the gate knob hub coincide with the holding set screws. Tighten the holding set screws above and below the knob assembly.

TO REPLACE THE GATE KNOB SPRING:

Open gate to fullest open position. Remove the screws at the center of the gate knob. Remove the gate knob by pulling it straight off. Remove old spring.

Insert new spring so that the inner end engages in the hole at the bottom of the recess in the gate knob.

Hold the knob so that the slot is in 90 degree position to the cross pin in the gate knob shaft. Engage the outer end of the spring into the nearest hole in the knob. Holding the knob, securely on the shaft but not engaged with the cross pin, rotate it to the right one and a quarter turns and push the knob into engagement with the cross pin.

Replace the screw at the center of the knob and tighten securely.

If less knob tension is desired, proceed as above except when engaging the knob with the spring. Hold the knob so the slot is parallel to the cross pin and then engage the outer end of the spring into the nearest hole in the knob. Holding the knob securely as above, rotate it to the right one turn and push the knob into engagement with the cross pin.

Replace the screw at the center of the knob.

REPLACING THE FILM GATE PADS:

Remove the gate. There is one screw holding each of the four film pads. The screw should be removed from the pad being replaced and the new pad screwed into place. After replacing all the pads; they should be inspected to make sure they are free to move in and out.

TO REPLACE THE PILOT LIGHT:

Unscrew the pilot light shield shown in #11-Fig. 1, and remove it. Unscrew the pilot light from its socket and replace it with a 110 Volt 7.5 watt G.E. Candelabra base mazda lamp.

REMOVING THE SHUTTER GUARDS:

The shutter guard on the driving side of the projector is removed by taking out the two screws #10-Fig.2 - which hold it to the "fixed" shutter guard. One of these screws is at the top of the guard and the other is at the bottom.

The shutter guard on the operating side of the projector is removed as follows: On the driving side of the projector there are two holding screws #11-Fig.2 - for the shutter guard. These should be removed. On the operating side of the projector the large screw just below the heat shield #12-Fig.1, should be removed. The shutter guard can then be removed.

TO REPLACE THE UPPER OR LOWER SPROCKET:

Open the pad roller arm. Take out the screw #13-Fig. 1 - at the center of the sprocket hub and pull the sprocket off the shaft. You will note that the screw holding the sprocket goes all the way thru the sprocket and clamps the sprocket to the shaft. This feature prevents the shaft from bending under the strain of the set screw.

Both the upper and lower sprockets are reversible.

When the new sprocket is installed, the sprocket drive gear should be held tightly against its bearing and the sprocket held firmly against its bearing. The holding screw should now be tightened. This will take out the end play of the shaft.

TO TAKE OUT THE APERTURE PLATE:

Pull out the aperture retaining plate shown in #14-Fig.1, which is behind the aperture plate. This frees the aperture plate so that it can move a little toward the rear and then it can be pulled directly out of its holder.

It will be noted that the aperture plate is held in position by its specially designed shape. The four corners are carefully fitted into the film trap and keep the aperture plate accurately located.

SETTING THE HEIGHT OF THE FIRE SHUTTER:

At the top of the governor which is on the vertical shaft there is a set screw #12-Fig. 2, which locks the governor to the shaft. Loosen this screw and the governor may be raised or lowered; this will raise or lower the fire shutter. When the proper

shutter height is obtained the set screw should be firmly tightened. The height of the shutter should be adjusted so that it does not come into the light beam with the projector running and yet not high enough to touch the top of the heat shield.

TO CLEAN THE THREADING REFLECTOR:

Take out the heat shield and wipe the threading reflector with a soft cloth. If the reflector is very dirty it should be polished with a good metal polish.

REMOVING THE UPPER OR LOWER PAD ROLLERS:

Loosen the retaining screw in the pad roller arm and pull the shaft and roller straight out of the arm. When the roller is replaced, the shaft should be adjusted so that the roller turns freely but has very little end play.

TO REMOVE THE UPPER PAD ROLLER ARM COMPLETE:

Loosen the retaining screw #15-Fig. 1 - with a screw driver thru a hole #16-Fig. 1, in the front of the projector case. The complete pad roller arm will then pull straight out.

Installing the pad roller arm, insert the pad roller arm stud into its hole in the main frame. Loosen the adjusting screw #5-Fig. 1, and back it out of contact with its stop. Rotate the arm into firm contact with the sprocket by means of the stud knob #17-Fig. 1, and tighten the screw #15-Fig. 1. Adjust the adjusting screw #5- until it comes into contact with its stop. Place two layers of film between the sprocket and the pad roller. Adjust the adjusting screw until the pad roller holds the film lightly in place. Lock the adjusting screw with its lock nut.

TO REPLACE THE LOWER PAD ROLLER ARM COMPLETE:

The procedure is the same as with the upper pad roller arm except that the screw driver is inserted thru a hole #18-Fig. 1, in the projector case at the back of the projector to loosen set screw #19 - Fig. 1.

Installation of the lower pad roller arm is made in the same manner as the upper pad roller arm explained above.

TO REPLACE THE INTERMITTENT PAD SHOE ASSEMBLY COMPLETE:

Loosen holding screw #7-Fig. 3. The complete Pad assembly will now pull straight out.

To install a new pad assembly push firmly into the holding hole and turn the pads so that they just make contact with the intermittent sprocket with little or no pressure being applied. When film is threaded thru the intermittent it will depress the pad shoes by an amount corresponding to the thickness of the film. This will be the correct amount of tension for best operation.

REMOVING THE SHUTTER SHAFT COMPLETE:

Open the driving side door and loosen the screw #13-Fig. 2, holding the shutter knob. The knob will then slip off the end of the shutter shaft. Take off the driving side shutter guard. Take out the four screws holding the rear bearing bracket of the shutter shaft #14-Fig. 2. Take out the two screws holding the front bearing bracket of the shutter shaft #15-Fig. 2. This bearing is dowel pinned in position. Holding the shutter shaft in both hands, disengage from the dowel pins and remove the shutter shaft complete including the shutter.

Replacing the shutter shaft reverse the above procedure.

The two screws #15-Fig. 2, in the front bearing bracket are tightened first. It will be noted that the ball bearings are self aligning. Before tightening the four screws #14-Fig. 2, in the rear bearing bracket the gear mesh should be adjusted between the shutter shaft gear and the driving gear on the vertical shaft. These two gears should be meshed close enough to prevent an excessive amount of backlash but not sufficiently close to cause binding.

REMOVING THE VERTICAL SHAFT COMPLETE:

Remove the shutter shaft complete as explained above. Remove the intermittent movement. See "REMOVING THE INTERMITTENT". Take out the two screws in the upper bearing bracket #16-Fig. 2. Take out the two screws in the lower bearing bracket #17-Fig. 2. Take out the two bolts in the intermittent drive gear bracket #18-Fig. 2. Disengage this bracket from its holder. The upper and lower bearings brackets are dowel pinned in position. Holding the vertical shaft with both hands, disengage the brackets from the dowel pins and remove the vertical shaft.

To put in a new vertical shaft, reverse the above procedure.

REMOVING THE MAIN DRIVE SHAFT AND GEAR:

Refer to Fig. 2. Remove the two set screws #4. This will allow the removal of the main drive shaft #1, by pulling it straight out. The main drive gear #2, can now be removed from the projector.

To assemble the main drive shaft and gear, proceed as follows: If the main drive shaft ball bearing retainer #9 is not out, remove it by loosening the retainer holding screw #8 and push it out. Insert the outer ball bearing in its place. Working from the non-operating side of the projector push the main drive shaft thru the outer ball bearing; put on the steel and then the fibre washers. Put on the main drive gear and then the fibre and steel washers. Insert the inner ball bearing from the operating

side of the projector. Insert the main ball bearing retainer. Push the retainer firmly into place and tighten the retainer holding screw. There should be no end play in this shaft after the assembly is complete.

REMOVING THE FILM GATE SUPPORT AND LENS HOLDER:

Take the lens out of the holder. By means of the focusing knob move the lens clamp all the way forward. Remove the focusing knob by removing the screw which holds it and pull the knob straight off the focusing shaft. Close the gate. Take out the two screws which will be exposed on the back side of the holder. Open the gate. The lens holder and film gate are located by means of dowel pins. The holder may now be removed from the projector.

To replace the holder in position, reverse the above operation.

YEARLY:

1. Drain the intermittent oil. When removing the drain screw, note the sequence of installation of the (3) washers. Replace the oil using **only** genuine Century Projector Oil; **DO NOT OVERFILL**. Replace the drain screw and all (3) washers in the correct sequence illustrated (copper washer against intermittent case) to prevent oil seepage.

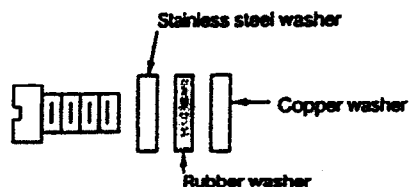

**MODEL C CENTURY PROJECTOR
OPERATING SIDE**

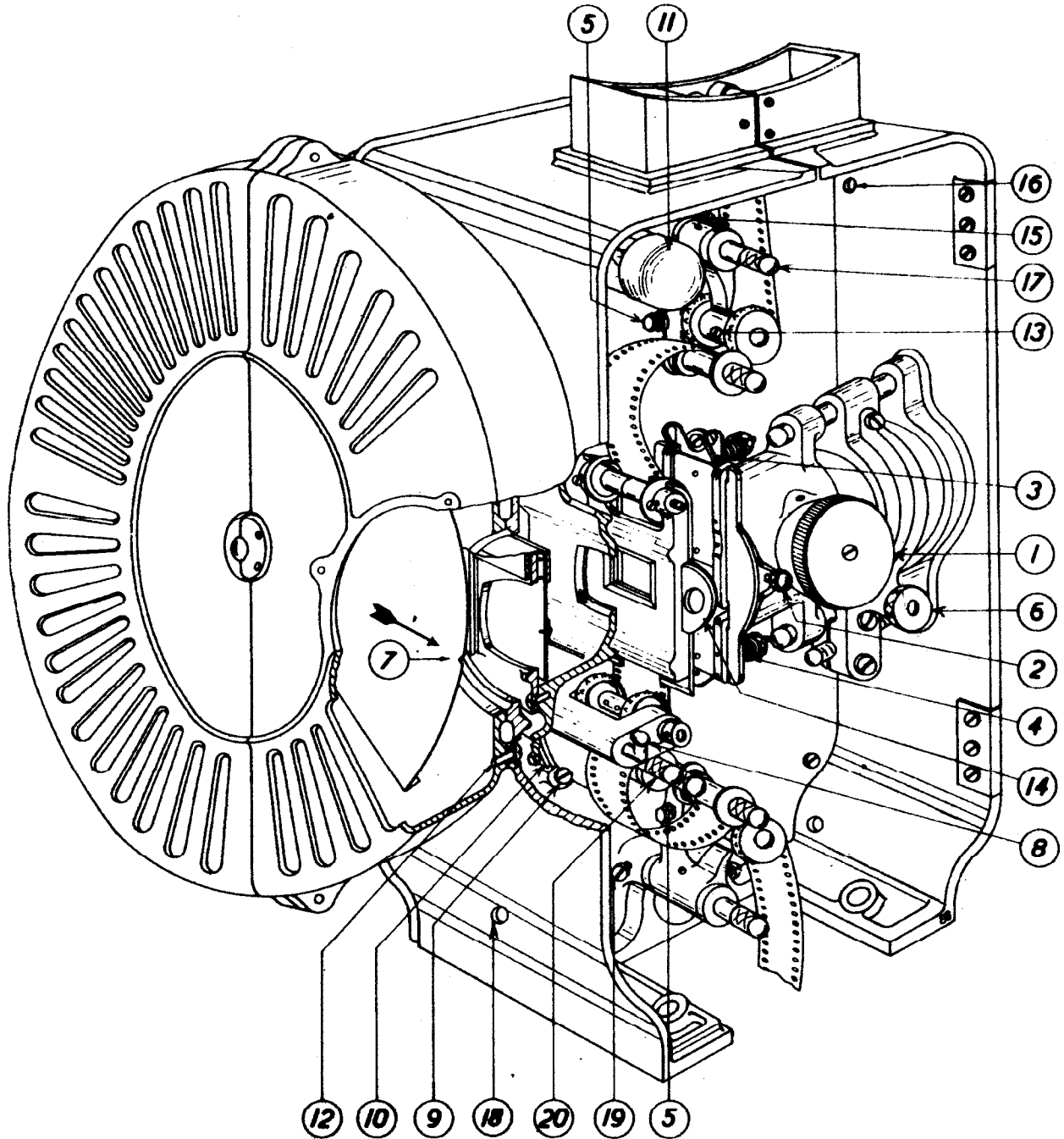

FIGURE 1

**MODEL C CENTURY PROJECTOR
DRIVING SIDE**

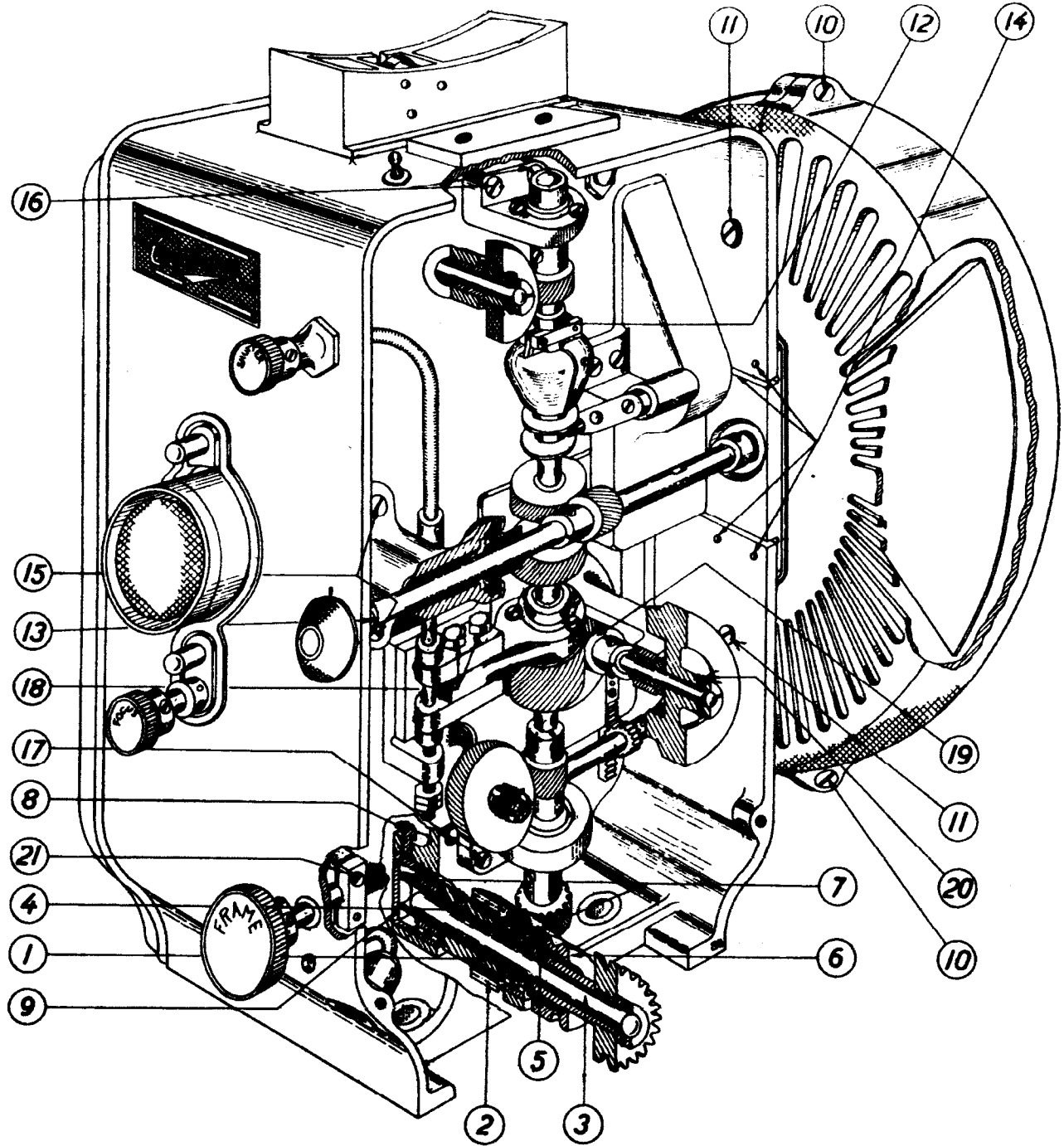

FIGURE 2

MODEL C CENTURY PROJECTOR INTERMITTENT MOVEMENT

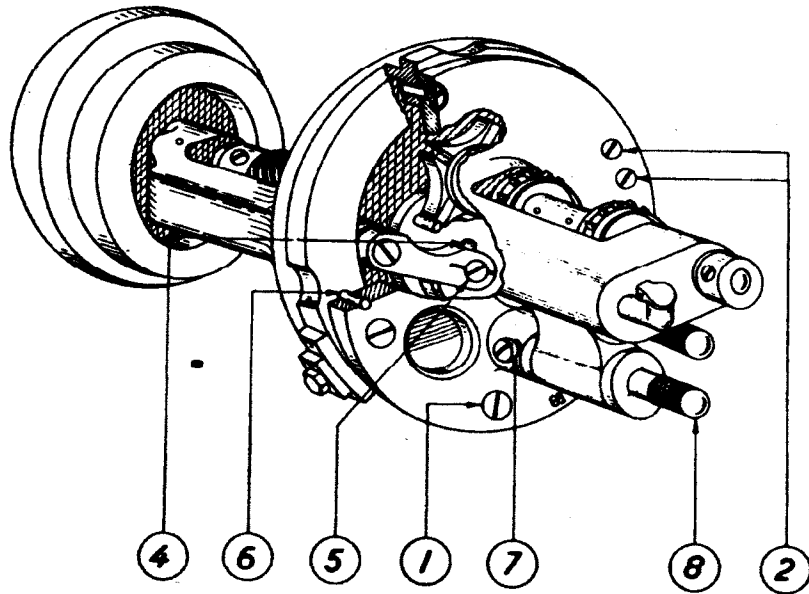

FIGURE 3

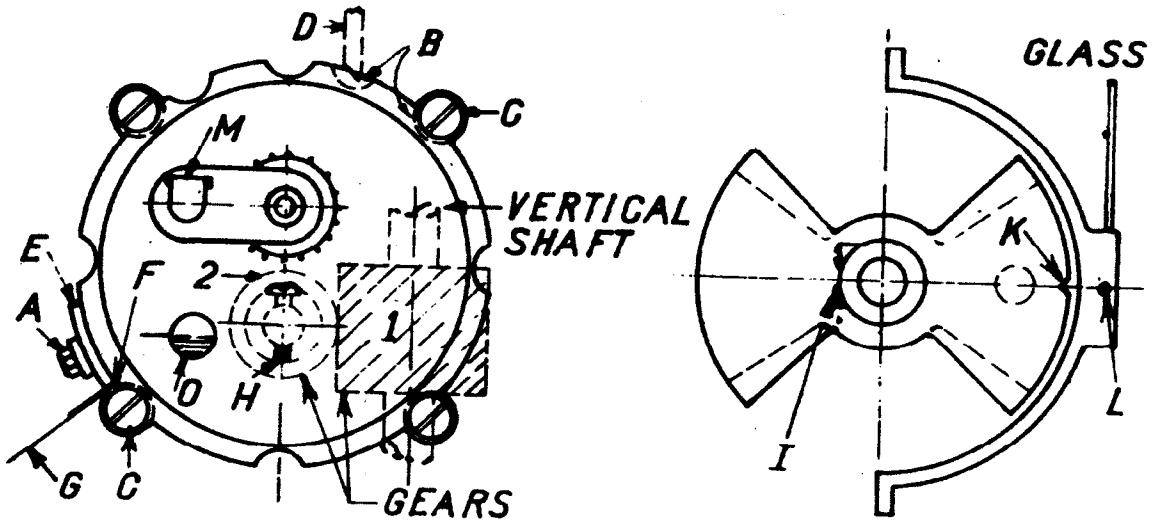

FIGURE 4



KELMAR

Systems Inc., 284 Broadway, Huntington Station, NY 11746 • 516.421.1230 • FAX 516.421.1274

Projector Upgrade Systems

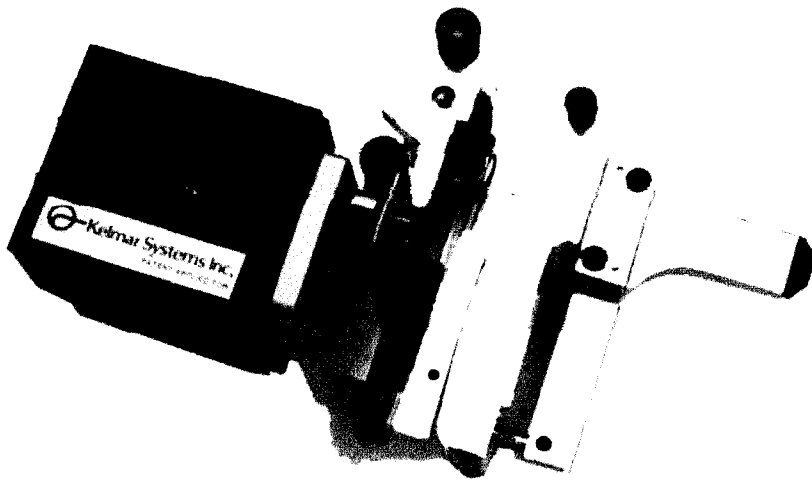

Retrofit Gate/Trap

Provides ideal film path geometry, extreme accuracy, automatic aperture change and unique field-replaceable runner plate surfaces. Gate and trap assemblies for both the Simplex and Century projectors retrofit directly to existing index pins and mounting holes.

Turret features ease of installation, fully automatic operation, vertical and lateral individual lens adjustment and micrometer focusing. DC drive and control logic accepts commands from all automation systems and accomplishes full lens change cycles in just two seconds.



CTC Century Model C Gate, Trap & Turret Net \$1,985.00

PARTS LIST

722



CENTURY FISHING CORPORATION

WATERBURY, CONNECTICUT

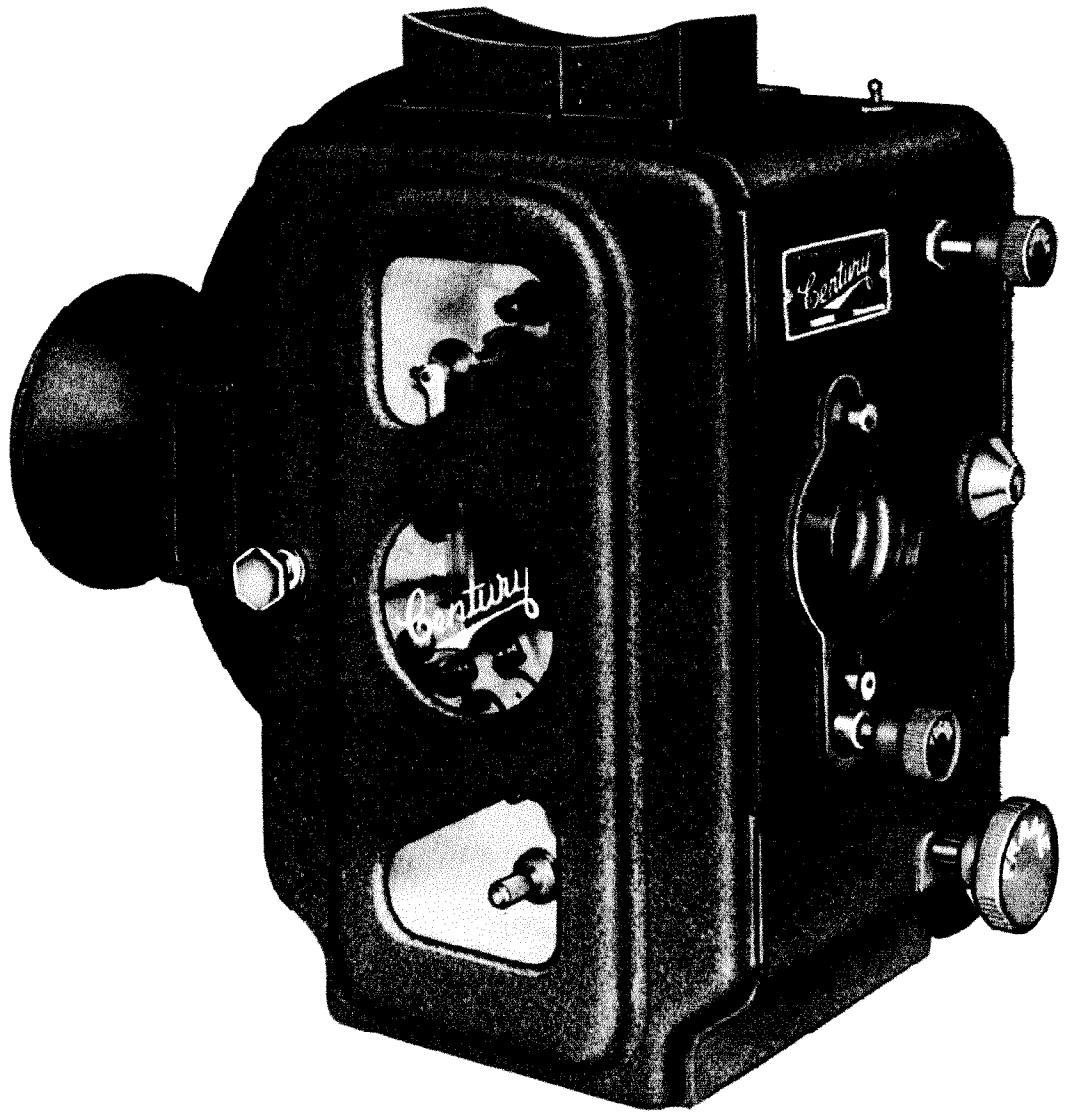

Century Model "C" Single Shutter Mechanism
Century Model "CC" Double Shutter Mechanism

The Century Single and Double Shutter Mechanisms are designed so that a large number of the parts in this catalogue are assembled into complete assemblies and sub-assemblies. The system of numbering used in the catalogue provides a simple and easy way to find the parts and sub-assemblies making up any complete assembly.

Each complete assembly performing a particular duty is assigned a number ending in "0" as C1-BB-20. This complete number designates that the assembly is for the Century Mechanism, (C1), the (BB) designates that it is the intermittent movement, the (20) designates that it is the complete intermittent movement. Sub-assemblies making up the movement will have a number ending in 1, 2, 3, etc. For example C1-BB-21 designates that it is the first assembly of the intermittent movement and belongs to the complete assembly C1-BB-20.

Each part has been assigned a number which designates what the part is, its number and the position of the part in the mechanism. For example BU-28-BB means that the part is a bushing (BU), the part number is (28) and it is used on the intermittent movement (BB).

The prefix denoting the name of the part is as follows:

AD	Adapter	GL	Glass	RO	Roller
AR	Arm	GR	Gear	RT	Retainer
BD	Blade	GU	Guide	RV	Rivet
BG	Bearing	HB	Hub	SA	Spacer
BL	Ball	HD	Hood	SB	Stop
BR	Bracket	HO	Holder	SC	Screw
BU	Bushing	KN	Knob	SD	Shield
CA	Carriage	KY	Key	SG	Spring
CG	Coupling	LE	Lever	SH	Shoe
CK	Crank	LI	Link	SK	Sprocket
CL	Collar	LO	Lock	SO	Support
CM	Cam	LT	Light	SP	Stripper
CP	Clamp	NU	Nut	ST	Shaft
CR	Cover	PA	Pad	SU	Stud
CS	Case	PE	Plate	SV	Sleeve
CU	Cup	PG	Plug	SW	Switch
DE	Deflector	PI	Pinion	SX	Starwheel
DO	Door	PN	Pin	TR	Trap
EC	Eccentric	PT	Pivot	TU	Tube
FR	Frame	PY	Pulley	WA	Washer
GA	Gasket	RD	Rod	WH	Wheel
GD	Guard	RE	Reflector	WI	Wire
GI	Gib	RK	Rack	WT	Weight

Page No. 26 of the price list gives the prices of the various assemblies and the remainder of the price sheets give the prices of the individual parts.

"A" Assemblies complete include the following:	Page No.
C1-A-10 Main Frame and Doors	
C1-A-20 Framing Shaft	11
C1-A-30 Intermittent Carriage and Shutter Adjustment	11
C1-A-40 Lens Holder and Film Gate Support	12
C1-A-50 Pilot Light, Socket and Plug	13
 "B" Assemblies complete include the following:	
C1-BB-20 Intermittent Movement	13
 "C" Assemblies complete include the following:	
C1-C-10 Upper Pad Roller Arm	15
C1-C-30 Lower Pad Roller Arm	15
 "D" Assemblies complete include the following:	
C1-D-10 Upper Sprocket Shaft	16
C1-D-20 Lower Sprocket Shaft	16
C1-D-30 Heat Shield	16
C1-D-40 Single Shutter Shaft and Guard	16
C1-D-50 Double Shutter Shaft and Guard	18
C1-D-60 Automatic Fire Shutter	19
 "E" Assemblies complete include the following:	
C1-E-10 Film Trap	20
C1-E-20 Film Gate	20
 "G" Assemblies complete include the following:	
C1-G-10 Main Drive	21
C1-G-30 Vertical Shaft and Governor	21
 "T" Assemblies complete include the following:	
C1-T-10 Conversion parts for use with Western Electric "D" Spec Reproducer	22
C1-T-20 Conversion Parts for Western Electric No. 209 and No. 211 Reproducers	22
C1-T-30 Conversion Parts for Western Electric No. 208 Reproducers	22
C1-T-40 Conversion Parts for Western Electric Universal Base Reproducers	23
C1-T-60 Conversion Parts for very Long Lenses	23
C1-T-120 Conversion Parts for Western Electric No. 206 Reproducers	23
C1-T-130 Conversion Parts for R. C. A. No. PS-8 Reproducers	23

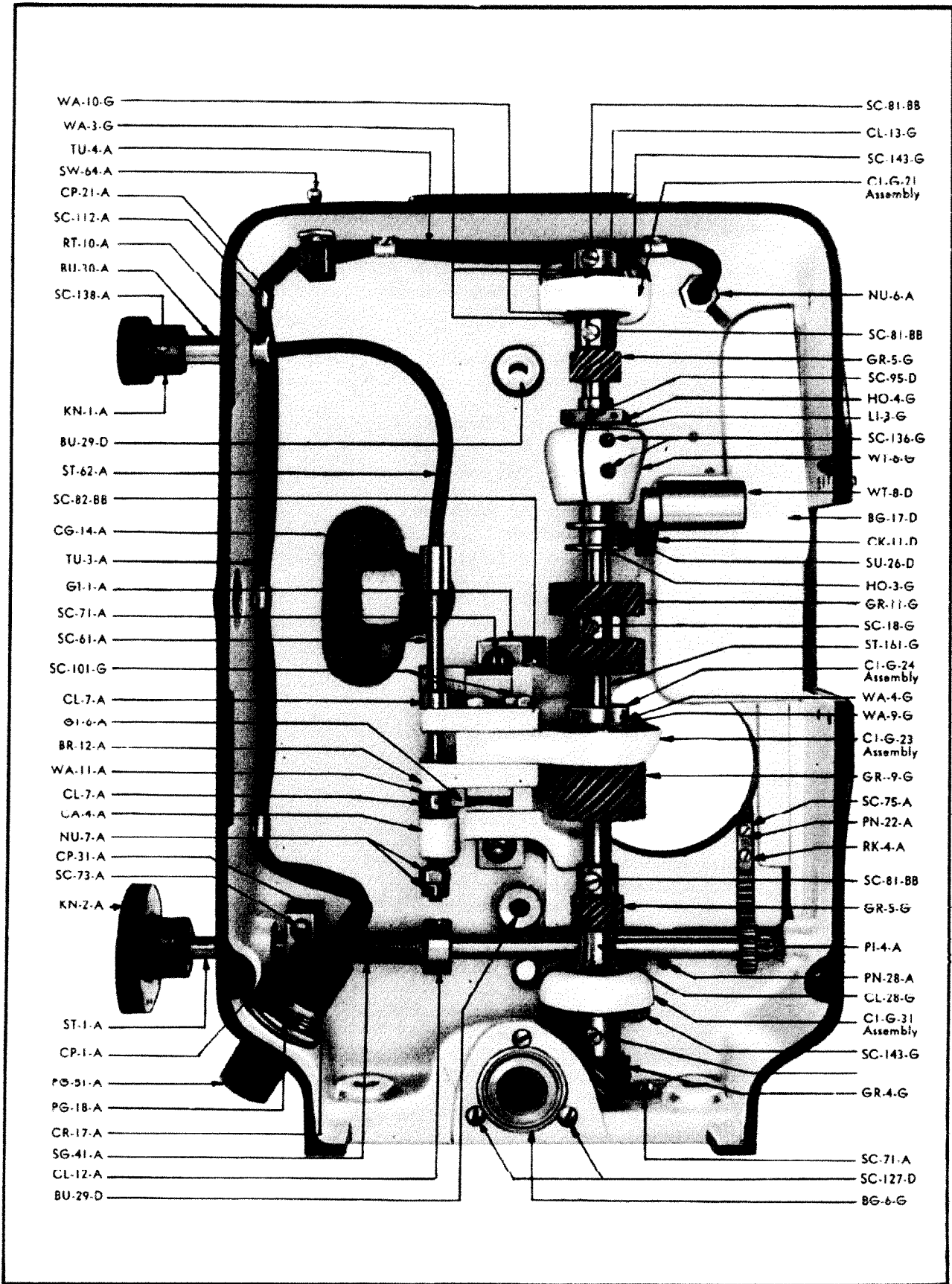

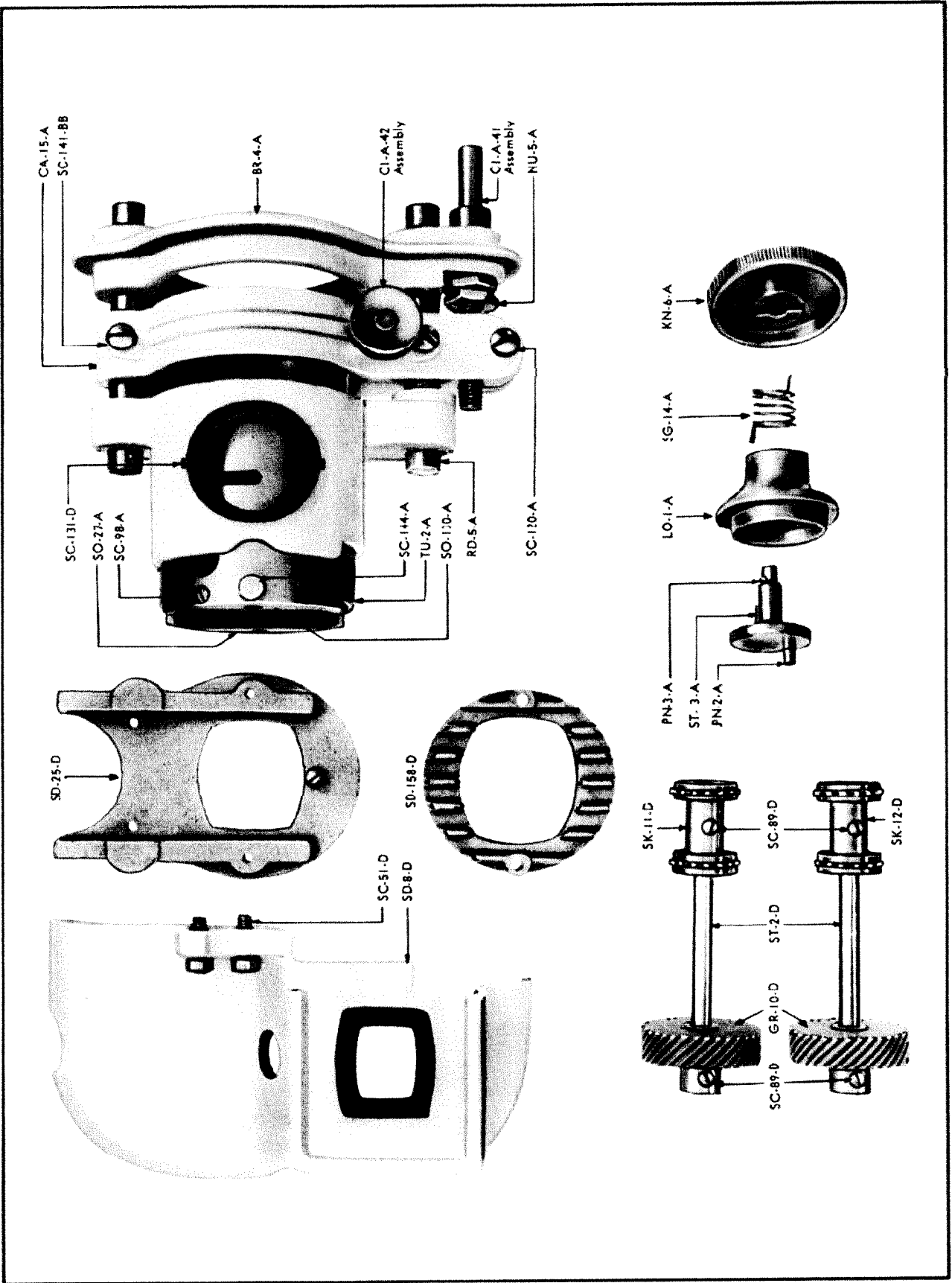

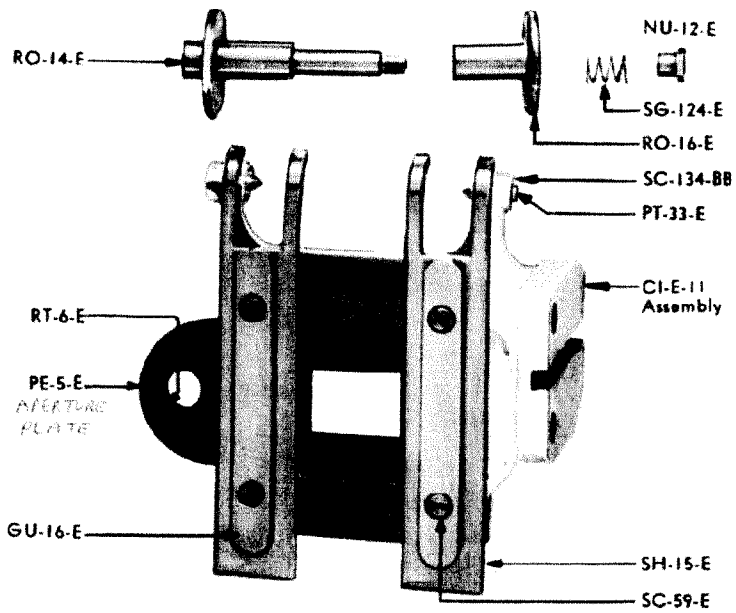
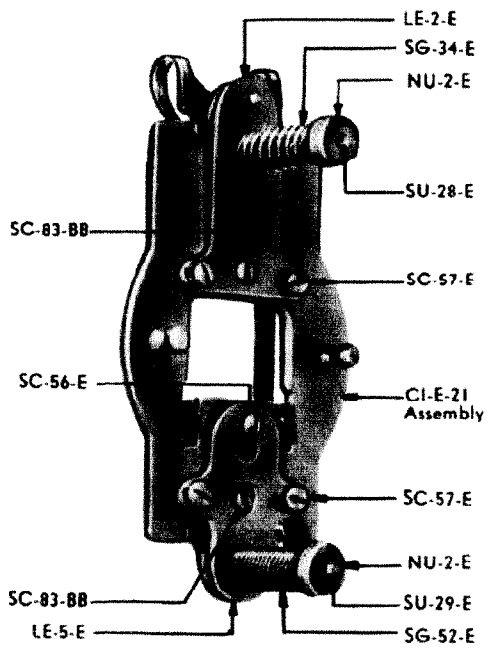
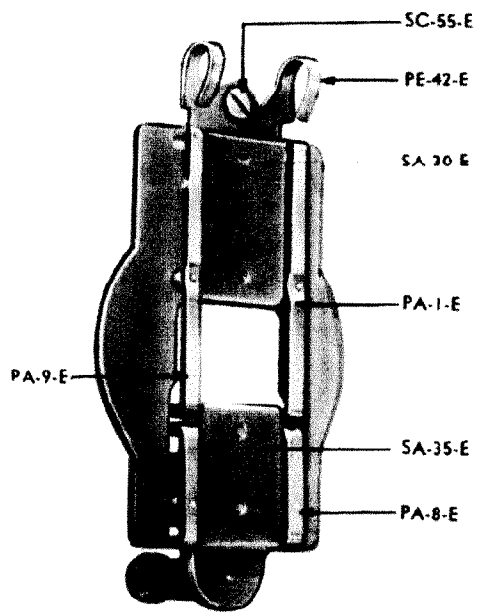

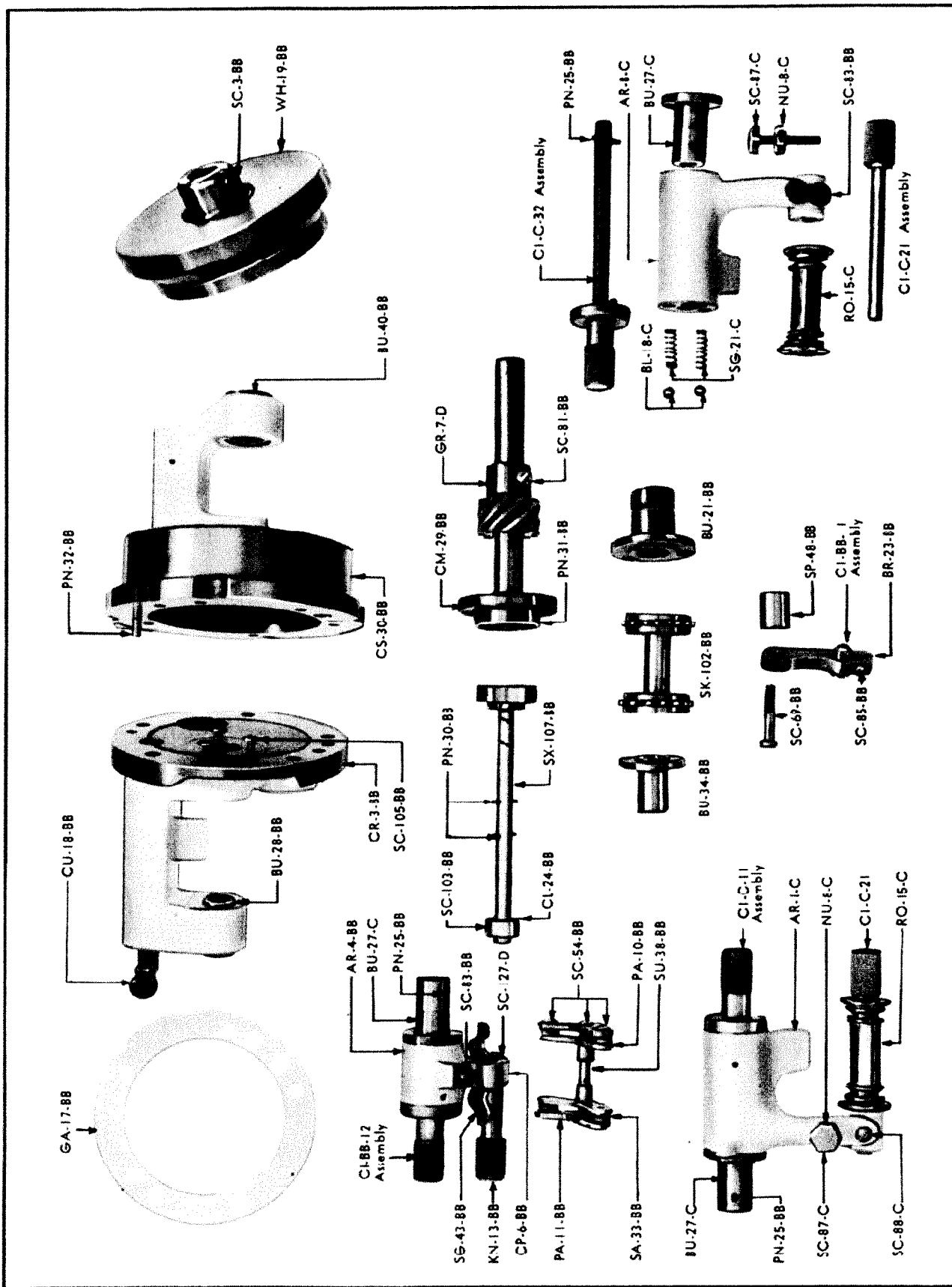

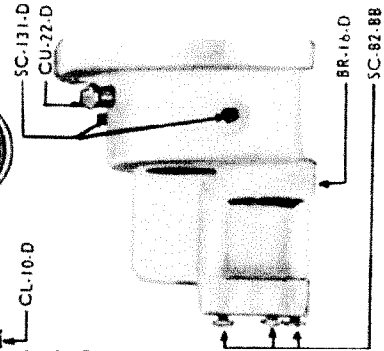
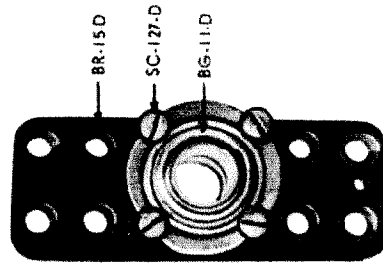
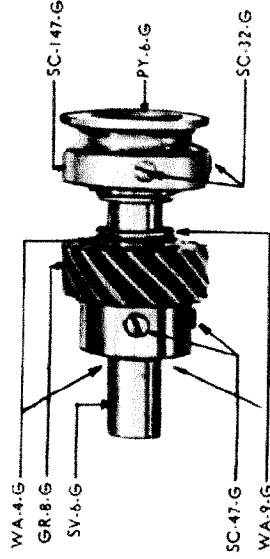
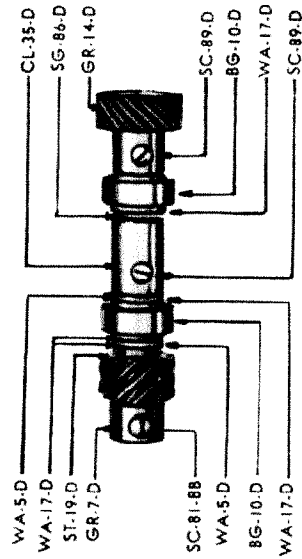
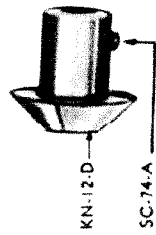
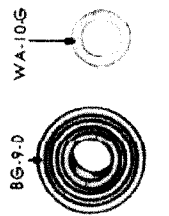
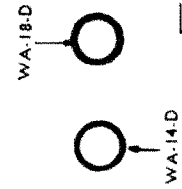
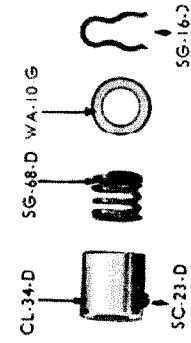
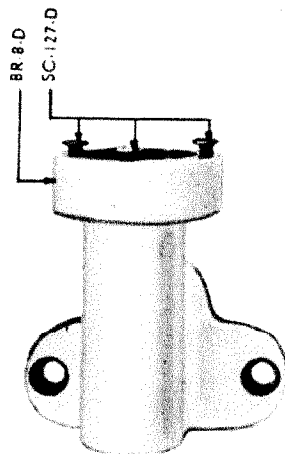
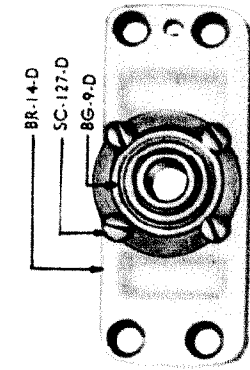

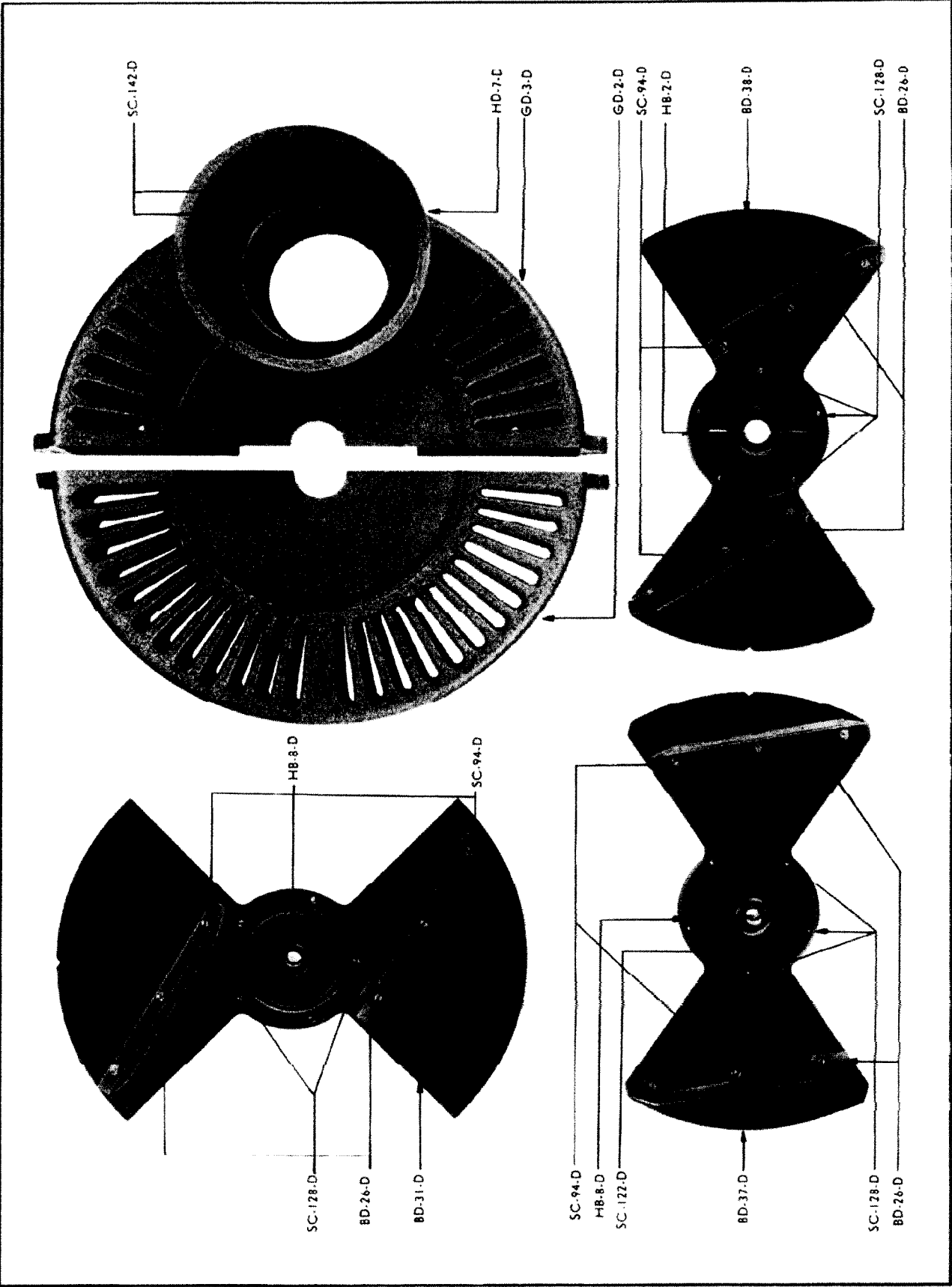

ORDER BY PART NUMBER

PART NO.	DESCRIPTION
CI-A-11	DOOR HINGE AND PIN ASSEMBLY
PE-15-A	Plate, Door Hinge (flat) *
PE-16-A	Plate, Door Hinge (bent) *
PN-17-A	Pin, Door Hinge *
CI-A-12	OPERATING SIDE DOOR ASSEMBLY
CI-A-11	Door Hinge Assembly (2)
CI-A-15	Door Lock Spring Assembly
CP-20-A	Clamp, Door Glass (6)
DO-1-A	Door, Operating Side
GL-15-A	Glass, Door
KN-8-A	Knob, Door
LI-7-A	Link, Door Stop
SB-60-A	Stop, Door Closing (felt) (2)
SC-70-A	Screw, Door Hinge (6)
SC-110-A	Screw, Door Stop Link
SC-111-A	Screw, Door Knob Fastening (2)
SC-123-A	Screw, Door Lock and Glass Clamp (8)
CI-A-13	NON-OPERATING DOOR ASSEMBLY
CI-A-11	Door Hinge Assembly (2)
CI-A-15	Door Lock Spring Assembly
DO-2-A	Door, Non-operating Side
KN-8-A	Knob, Non-operating Side Door
LI-7-A	Link, Door Stop
SB-60-A	Stop, Door Closing (felt) (2)
SC-70-A	Screw, Door Hinge (6)
SC-110-A	Screw, Door Stop Link
SC-111-A	Screw, Door Knob Fastening (2)
SC-123-A	Screw, Door Lock (2)
CI-A-14	UPPER MAGAZINE ROLLER HOLDER ASSEMBLY
HO-6-A	Holder, Upper Magazine Roller
RO-12-A	Roller, Upper Magazine (large)
RO-13-A	Roller, Upper Magazine (small) (2)
SC-115-A	Screw, Upper Magazine Roller (6)
CI-A-15	DOOR LOCK SPRING ASSEMBLY
BN-35-A	Button, Door Lock Spring *
SG-109-A	Spring, Door Lock *
CENTER FRAME PINS, SCREWS AND PARTS	
CR-5-A	Cover, Non-operating Side
PN-21-A	Pin, Film Trap and Vertical Shaft Bearing Bracket (3)
PN-24-A	Pin, Lens Holder and Inner Shutter Bracket (2)
PN-27-A	Pin, Film Trap and Carriage Stop
PN-28-A	Pin, Shutter Bracket and Carriage Stop (2)
SC-17-A	Screw, Non-operating Side Door Lock Stop
SC-70-A	Screw, Door Hinge Mounting (12)
SC-71-A	Screw, Vertical Shaft Drive Gear Safety
SC-108-A	Screw, Operating Side Door Lock Stop
SC-110-A	Screw, Door Stop Link (2)
SC-113-A	Screw, Non-operating Side Cover Fastening (2)
SC-116-A	Screw, Upper Magazine Roller Holder Fastening (long)
SC-117-A	Screw, Upper Magazine Roller Holder Fastening (short) (2)

*Parts Not Sold Separately

ORDER BY PART NUMBER

PART NO.	DESCRIPTION
C1-A-20	FRAMING SHAFT ASSEMBLY
C1-A-21	Framing Shaft and Pinion Sub-assembly
CL-12-A	Collar, Framing Shaft
CP-1-A	Clamp, Framing Shaft (with hole)
CP-31-A	Clamp, Framing Shaft (without hole)
KN-2-A	Knob, Framing
SC-73-A	Screw, Framing Shaft Clamp (upper)
SC-74-A	Screw, Framing Shaft Collar
SC-132-A	Screw, Framing Shaft Clamp (lower)
SC-140-A	Screw, Framing Knob
SG-41-A	Spring, Framing Shaft Tension
WA-11-A	Washer, Framing Shaft Clamp Spacer
C1-A-21	FRAMING SHAFT AND PINION ASSEMBLY
PI-4-A	Pinion, Framing Shaft
PN-29-A	Pin, Framing Shaft Pinion
ST-1-A	Shaft, Framing
C1-A-30	INTERMITTENT CARRIAGE AND SHUTTER ADJUSTMENT ASSEMBLY
C1-A-33	Intermittent Carriage Assembly
BU-30-A	Bushing, Shutter Adjustment Retainer
CG-14-A	Coupling, Shutter Adjustment
KN-1-A	Knob, Shutter Adjustment
RT-10-A	Retainer, Shutter Adjustment Flexible Shaft
SC-77-A	Screw, Shutter Adjustment Coupling (3)
SC-138-A	Screw, Shutter Adjustment Knob
ST-62-A	Shaft, Shutter Adjustment Flexible
C1-A-32	SHUTTER ADJUSTMENT SCREW AND COLLAR ASSEMBLY
CL-7-A	Collar, Shutter Adjustment Rod Thrust (2)
PN-23-A	Pin, Shutter Adjustment Rod and Collar (2)
SC-61-A	Screw, Shutter Adjustment
C1-A-33	INTERMITTENT CARRIAGE ASSEMBLY
C1-A-32	Shutter Adjustment Screw and Collar Assembly
CA-4-A	Carriage, Intermittent
BR-12-A	Bracket, Shutter Adjustment
GI-6-A	Gib, Shutter Adjustment Bracket
NU-7-A	Nut, Shutter Adjustment Rod Stop (2)
PN-22-A	Pin, Intermittent Carriage Rack
RK-4-A	Rack, Framing
RT-3-A	Retainer, Intermittent Carriage Spring (2)
SC-75-A	Screw, Framing Rack Fastening (2)
SC-78-A	Screw, Shutter Adjustment Bracket Gib (2)
SC-82-A	Screw, Intermittent Carriage Spring Retainer (2)
SC-101-G	Screw, Vertical Intermittent Drive Bearing Bracket (2)
SC-106-BB	Screw, Intermittent Fastening (4)
SG-100-A	Spring, Shutter Adjustment Bracket Tension
WA-11-A	Washer, Shutter Adjustment Screw
GI-1-A	Gib, Intermittent Carriage
SC-71-A	Screw, Intermittent Carriage Gib Fastening (2)
SG-58-A	Spring, Intermittent Carriage Gib

ORDER BY PART NUMBER

PART NO.	DESCRIPTION
C1-A-40	LENS HOLDER AND FILM GATE SUPPORT ASSEMBLY
C1-A-41	Focusing Screw and Collar Assembly
C1-A-43	Lens Carrier Assembly
C1-A-44	Film Gate Support and Tube Assembly
C1-A-45	Film Gate Lock, Knob and Shaft Assembly
BR-4-A	Bracket, Lens Holder and Film Gate
EC-1-A	Eccentric, Film Gate Alignment
KN-3-A	Knob, Lens Focusing
NU-5-A	Nut, Lens Focusing Screw Stop (2)
RD-5-A	Rod, Lens Carrier Guide (2)
SC-72-A	Screw, Lens Focusing Knob
SC-76-A	Screw, Film Gate Alignment Eccentric Lock
SC-131-D	Screw, Film Gate Lock Fastening (2)
SC-144-A	Screw, Gate Retaining Thumb
SC-79-A	Screw, Lens Holder Mounting (2)
C1-A-41	FOCUSING SCREW AND COLLAR ASSEMBLY
CL-25-A	Collar, Focusing Screw Thrust
PN-34-A	Pin, Focusing Screw Thrust Collar
SC-20-A	Screw, Focusing
C1-A-42	LENS CLAMP SCREW AND KNOB ASSEMBLY
KN-9-A	Knob, Lens Clamp *
PN-34-A	Pin, Lens Clamp Screw and Knob *
SC-118-A	Screw, Lens Clamp *
C1-A-43	LENS CARRIER ASSEMBLY
C1-A-42	Lens Clamp Screw and Knob Assembly
CA-15-A	Carrier, Lens
SC-120-A	Screw, Focusing Shaft Clamping
SC-141-BB	Screw, Lens Guide Rod Fastening (2)
WA-20-A	Washer, Focusing Shaft Clamping Screw Lock
WA-21-A	Washer, Lens Clamp Screw
C1-A-44	FILM GATE SUPPORT AND TUBE ASSEMBLY
SC-98-A	Screw, Gate Support Fastening (4)
SO-27-A	Support, Gate (inner)
SO-130-A	Support, Gate (outer)
TU-2-A	Tube, Lens Holder
C1-A-45	FILM GATE LOCK, KNOB AND SHAFT ASSEMBLY
C1-A-46	Film Gate Lock Shaft and Pin Assembly
KN-6-A	Knob, Film Gate Opening
LO-1-A	Lock, Film Gate
SC-99-A	Screw, Film Gate Knob Fastening
SG-14-A	Spring, Film Gate Opening
C1-A-46	FILM GATE LOCK SHAFT AND PIN ASSEMBLY
PN-2-A	Pin, Film Gate Locking *
PN-3-A	Pin, Film Gate Knob *
ST-13-A	Shaft, Film Gate Lock *

*Parts Not Sold Separately

ORDER BY PART NUMBER

PART NO.	DESCRIPTION
C1-A-50	PILOT LIGHT, SOCKET AND PLUG ASSEMBLY
C1-A-54	Pilot Light Switch and Wire Assembly
CR-17-A	Cover, Terminal
PG-18-A	Plug, Male with Plate and Locking Ring
PG-51-A	Plug, Female
C1-A-51	PILOT LIGHT SOCKET AND SUPPORT ASSEMBLY
SA-67-A	Spacer, Pilot Light *
SF-65-A	Socket, Pilot Light *
SO-36-A	Support, Pilot Light *
WA-30-A	Washer, Pilot Light *
C1-A-52	PILOT LIGHT SOCKET, BULB AND GUARD ASSEMBLY
C1-A-51	Pilot Light Socket and Support Assembly
C1-A-53	Pilot Light Guard Assembly
BU-22-A	Bushing, Pilot Light
LT-6-A	Bulb, Pilot Light
NU-6-A	Nut, Pilot Light
SC-172-A	Screw, Pilot Light Locating
C1-A-53	PILOT LIGHT GUARD ASSEMBLY
SD-37-A	Shield, Pilot Light (metal) *
SD-66-A	Shield, Pilot Light (glass) *
C1-A-54	PILOT LIGHT SWITCH AND WIRE ASSEMBLY
C1-A-52	Pilot Light Socket, Bulb and Guard Assembly
SW-64-A	Switch, Pilot Light
TU-3-A	Tube, Pilot Light Flexible Shield (long)
TU-4-A	Tube, Pilot Light Flexible Shield (short)
WI-13-A	Wire, Pilot Light Connecting
CP-21-A	Clamp, Wire (5)
SC-112-A	Screw, Wire Clamp (5)
C1-BB-20	INTERMITTENT MOVEMENT ASSEMBLY
C1-BB-11	Cam Ball Thrust Bearing Assembly
C1-BB-16	Cover Assembly
C1-BB-17	Case Assembly
C1-BB-22	Sprocket Pad Assembly
BR-23-BB	Bracket, Cam Thrust
CL-24-BB	Collar, Starwheel Thrust
CM-29-BB	Cam, (includes 1 PG-20-BB and 1 PN-31-BB)
GA-17-BB	Gasket, Case
GR-7-D	Gear, Cam Shaft
PE-38-BB	Plate, Stop (small)
PE-40-BB	Plate, Stop (large)
PG-20-BB	Plug, Cam Pin *
PN-30-BB	Pin, Starwheel & Sprocket Taper (2)
PN-31-BB	Pin, Cam
SC-3-BB	Screw, Flywheel Fastening
SC-39-BB	Screw, Adjusting (2)
SC-69-BB	Screw, Cam Thrust Bracket
SC-81-BB	Screw, Cam Shaft Gear Fastening
SC-85-BB	Screw, Cam Thrust Bearing

*Parts Not Sold Separately

ORDER BY PART NUMBER

PART NO.	DESCRIPTION
C1-BB-20	INTERMITTENT MOVEMENT ASSEMBLY (Continued)
SC-88-C	Screw, Intermittent Pad Arm Fastening
SC-103-BB	Screw, Starwheel Thrust Collar Fastening (2)
SC-104-BB	Screw, Cover Fastening (5)
SC-134-BB	Screw, Stop Plate
SC-141-BB	Screw, Pad Assembly Fastening
SK-102-BB	Sprocket, Intermittent (includes 2 PN-30-BB)
SA-48-BB	Spacer, Cam Thrust Bracket
SX-107-BB	Starwheel, Intermittent (includes 2 PN-30-BB)
WA-3-G	Washer, Intermittent Gear Thrust
WA-12-BB	Washer, Cover Fastening Screw (5)
WA-16-BB	Washer, Thrust
WH-19-BB	Flywheel
C1-BB-11	INTERMITTENT CAM BALL THRUST BEARING
BG-24-BB	Bearing, Cam Ball Thrust *
BL-18-C	Ball, Cam Shaft Thrust *
WA-7-BB	Washer, Cam Thrust *
C1-BB-16	INTERMITTENT COVER ASSEMBLY
BU-28-BB	Bushing, Cover (outer)
BU-34-BB	Bushing, Cover (inner)
CR-3-BB	Cover, (includes 2 PG-35-BB)
CU-18-BB	Cup, Cover Oil
GA-20-BB	Gasket, Oil Gauge (2)
GG-19-BB	Gauge, Oil
NU-10-BB	Nut, Oil Gauge
PG-35-BB	Plug, Cover Oil Hole (2)
SC-105-BB	Screw, Cover Inner Bushing Fastening (3)
C1-BB-17	INTERMITTENT CASE ASSEMBLY
BU-21-BB	Bushing, Case (inner)
BU-40-BB	Bushing, Case (outer)
CS-30-BB	Case (includes 3 PG-35-BB)
DE-3-BB	Deflector, Oil
PG-35-BB	Plug, Case Oil Hole (3)
PN-32-BB	Pin, Adjusting Pivot
PN-37-BB	Pin, Oil Deflector Retaining
SC-7-BB	Screw, Case Inner Bushing (3)
C1-BB-18	INTERMITTENT PAD STUD AND BUSHING ASSEMBLY
BU-27-C	Bushing, Pad
KN-7-C	Knob, Pad *
PN-25-BB	Pin, Pad Bushing
PN-36-BB	Pin, Pad Knob *
SU-4-BB	Stud, Pad *
C1-BB-21	INTERMITTENT SPROCKET PAD ARM AND SPRING ASSEMBLY
AR-4-BB	Arm, Sprocket Pad
KN-13-BB	Knob, Sprocket Pad
SC-45-BB	Screw, Sprocket Pad Retaining Spring
SC-127-BB	Screw, Sprocket Pad Knob
SG-43-BB	Spring, Sprocket Pad Retaining

*Parts Not Sold Separately

ORDER BY PART NUMBER

PART NO.	DESCRIPTION
C1-BB-22	INTERMITTENT SPROCKET PAD ASSEMBLY (Complete)
C1-BB-18	Sprocket Pad Stud and Bushing Assembly
C1-BB-21	Sprocket Pad Arm and Spring Assembly
C1-BB-23	Sprocket Pad Assembly
BL-18-C	Ball, Sprocket Pad Arm (2)
CP-6-BB	Clamp, Sprocket Pad Stud
SC-83-BB	Screw, Sprocket Pad Stud Clamp Fastening
SG-21-C	Spring, Pad Arm (2)
C1-BB-23	INTERMITTENT SPROCKET PAD ASSEMBLY
PA-10-BB	Pad, Sprocket (inner) (2)
PA-11-BB	Pad, Sprocket (outer) (2)
SA-33-BB	Spacer, Sprocket Pad (4)
SC-54-BB	Screw, Sprocket Pad Fastening (6)
SU-38-BB	Stud, Sprocket Pad
C1-C-10	UPPER PAD ROLLER ARM ASSEMBLY (Complete)
C1-C-13	Pad Roller Stud, Knob and Bushing Assembly
C1-C-21	Pad Roller Shaft and Knob Assembly
AR-1-C	Arm, Upper Pad Roller
BL-18-C	Ball, Pad Roller Bearing (2)
NU-8-C	Nut, Pad Roller Stop Screw
RO-15-C	Roller, Pad
SC-87-C	Screw, Pad Roller Stop
SC-88-C	Screw, Pad Roller Shaft Fastening
SG-21-C	Spring, Pad Roller (2)
SC-137-C	Screw, Pad Roller Assembly Fastening
C1-C-13	PAD ROLLER STUD, KNOB AND BUSHING ASSEMBLY
BU-27-C	Bushing, Pad Roller
KN-7-C	Knob, Pad Roller *
PN-25-BB	Pin, Pad Roller Bushing
PN-36-BB	Pin, Pad Roller Knob *
SU-49-C	Stud, Pad Roller (long) *
C1-C-21	PAD ROLLER SHAFT AND KNOB ASSEMBLY
KN-10-C	Knob, Pad Roller Shaft *
ST-50-C	Shaft, Pad Roller *
C1-C-30	LOWER PAD ROLLER ARM ASSEMBLY
C1-C-21	Pad Roller Shaft and Knob Assembly
C1-C-31	Pad Roller Stud, Knob and Bushing Assembly
AR-8-C	Arm, Lower Pad Roller
BL-18-C	Ball, Pad Roller Bearing (2)
NU-8-C	Nut, Pad Roller Stop Screw
HO-15-C	Roller, Pad
SC-83-BB	Screw, Pad Roller Shaft Fastening
SC-87-C	Screw, Pad Roller Stop
SG-21-C	Spring, Pad Roller (2)
SC-137-C	Screw, Pad Roller Assembly Fastening

*Parts Not Sold Separately

ORDER BY PART NUMBER

PART NO.	DESCRIPTION
C1-C-31	PAD ROLLER STUD, KNOB AND BUSHING ASSEMBLY
BU-27-C	Bushing, Pad Roller
KN-7-C	Knob, Pad Roller *
PN-25-BB	Pin, Pad Roller Bushing
PN-36-BB	Pin, Pad Roller Knob *
SU-40-C	Stud, Lower Pad Roller *
C1-D-10	UPPER SPROCKET SHAFT ASSEMBLY
GR-10-D	Gear, Upper Sprocket
SC-89-D	Screw, Sprocket and Gear Fastening (2)
SK-11-D	Sprocket, Upper
ST-2-D	Shaft, Sprocket
BU-29-D	Bushing, Sprocket Shaft (2)
CU-22-D	Cup, Sprocket Shaft Oil
C1-D-20	LOWER SPROCKET SHAFT ASSEMBLY
GR-10-D	Gear, Lower Sprocket
SC-89-D	Screw, Sprocket and Gear Fastening (2)
SK-12-D	Sprocket, Lower
ST-2-D	Shaft, Sprocket
BU-29-D	Bushing, Sprocket Shaft (2)
CU-22-D	Cup, Sprocket Shaft Oil
C1-D-30	HEAT SHIELD ASSEMBLY
SC-51-D	Screw, Heat Shield Fastening (2)
SD-8-D	Shield, Heat
SC-72-A	Screw, Baffle Plate Fastening (2)
SC-170-D	Screw, Baffle Plate (for Hi-Intensity) (2)
SD-25-D	Plate, Baffle and Change-over Slide
SD-158-D	Plate, Baffle (for Hi-Intensity)
C1-D-40	SINGLE SHUTTER SHAFT AND GUARD ASSEMBLY (Complete)
C1-D-41	Single Shutter Blade and Hub Assembly
C1-D-43	Shutter Guard Assembly
C1-D-44	Single Shutter Shaft and Bracket Assembly
HD-7-D	Hood, Light (3")
KN-12-D	Knob, Shutter Shaft Indicating
SC-74-A	Screw, Shutter Shaft Indicating Knob
SC-142-D	Screw, Light Hood Mounting (3)
SG-16-D	Spring, Shutter Shaft Hub Spacing
HD-10-D	Hood, Light (1")
C1-D-41	SINGLE SHUTTER BLADE AND HUB ASSEMBLY
C1-D-48	Single Shutter Blade and Draft Blade Assembly
HB-8-D	Hub, Single Shutter
SC-122-D	Screw, Single Shutter Hub Tightening (2)
SC-128-D	Screw, Single Shutter Blade and Hub Fastening (5)

*Parts Not Sold Separately

ORDER BY PART NUMBER

PART NO.	DESCRIPTION
C1-D-42	INNER SHUTTER SHAFT BRACKET AND BALL BEARING ASSEMBLY
BG-9-D	Bearing, Shutter Shaft Ball
BR-8-D	Bracket, Shutter Shaft (inner)
SC-127-D	Screw, Shutter Shaft Ball Bearing (3)
C1-D-43	SHUTTER GUARD ASSEMBLY
GD-2-D	Guard, Removable Shutter
GD-3-D	Guard, Fixed Shutter
GL-18-D	Glass, Spot Sight
HO 5-D	Holder, Shutter Guard Glass
PN-26-D	Pin, Shutter Guard Spring
PN-41-D	Pin, Shutter Guard Blade Setting
SC-91-D	Screw, Removable Shutter Guard Fastening (2)
SC-92-D	Screw, Spot Sight Holder Fastening (4)
SG-44-D	Spring, Spot Sight Glass
C1-D-44	SINGLE SHUTTER SHAFT AND BRACKET ASSEMBLY
C1-D-42	Inner Shutter Shaft Bracket and Ball Bearing Assembly
C1-D-45	Single Shutter Bracket and Ball Bearing Assembly
CL-34-D	Collar, Shutter Shaft Ball Bearing Tension
GR-7-D	Gear, Shutter Shaft
SC-23-D	Screw, Shutter Shaft Ball Bearing Tension Collar
SC-81-D	Screw, Shutter Shaft Gear Fastening
SG-68-D	Spring, Shutter Shaft Ball Bearing Tension
ST-10-D	Shaft, Shutter
WA-10-G	Washer, Ball Bearing Thrust (steel) (2)
WA-14-D	Washer, Shutter Shaft Spring Thrust
WA-18-D	Washer, Ball Bearing Thrust (fiber)
C1-D-45	SINGLE SHUTTER BRACKET AND BALL BEARING ASSEMBLY
BG-9-D	Bearing, Single Shutter Shaft Ball
BR-14-D	Bracket, Single Shutter Shaft (outer)
SC-127-D	Screw, Shutter Shaft Ball Bearing Fastening (4)
PN-24-A	Pin, Bracket Locating (inner)
PN-28-A	Pin, Bracket Locating (outer)
SC-79-A	Screw, Shutter Shaft Bracket Fastening (6)
SC-90-D	Screw, Shutter Guard Mounting (3)
C1-D-48	SINGLE SHUTTER BLADE AND DRAFT BLADE ASSEMBLY
BD-26-D	Blade, Shutter Blade Draft (2)
BD-31-D	Blade, Single Shutter
SC-94-D	Screw, Shutter Blade Draft Blade (6)

ORDER BY PART NUMBER

PART NO.	DESCRIPTION
C1-D-50	DOUBLE SHUTTER SHAFT AND GUARD ASSEMBLY (Complete)
C1-D-43	Shutter Guard Assembly
C1-D-51	Reverse Double Shutter and Hub Assembly
C1-D-52	Double Shutter Blade and Hub Assembly
C1-D-54	Double Shutter Shaft and Bracket Assembly
HD-7-D	Hood, Light (3")
KN-12-D	Knob, Shutter Shaft Indicator
SC-74-D	Screw, Shutter Shaft Indicator Knob
SC-142-D	Screw, Light Hood Fastening (3)
SG-16-D	Spring, Shutter Shaft Hub Spacing
C1-D-51	REVERSE DOUBLE SHUTTER BLADE AND HUB ASSEMBLY
C1-D-59	Reverse Double Shutter Blade and Draft Blade Assembly
HB 2-D	Hub, Inner Shutter
SC-122-D	Screw, Shutter Hub Tightening (2)
SC-128-D	Screw, Shutter Blade Hub Fastening (5)
C1-D-52	DOUBLE SHUTTER BLADE AND HUB ASSEMBLY
C1-D-58	Double Shutter Blade and Draft Blade Assembly
HB-8-D	Hub, Double Shutter (outer)
SC-122-D	Screw, Shutter Hub Tightening (2)
SC-128-D	Screw, Shutter Hub and Blade Fastening (5)
C1-D-53	DOUBLE SHUTTER BRACKET AND BALL BEARING ASSEMBLY
BG-11-D	Bearing, Double Reverse Shutter Ball (matched pair)
BR-15-D	Bracket, Double Shutter (small)
SC-127-D	Screw, Ball Bearing Fastening (4)
C1-D-54	DOUBLE SHUTTER SHAFT AND BRACKET ASSEMBLY
C1-D-42	Inner Shutter Shaft Bracket and Ball Bearing Assembly
C1-D-55	Double Shutter Intermediate Bracket Ball Bearing and Gear Assembly
CL-34-D	Collar, Shutter Shaft Ball Bearing Tension
GR-7-D	Gear, Shutter Shaft
SC-23-D	Screw, Ball Bearing Thrust Collar
SC-81-D	Screw, Shutter Shaft Gear Fastening
SG-68-D	Spring, Intermediate Shaft Ball Bearing Tension
ST-10-D	Shaft, Shutter
WA-10-G	Washer, Shutter Shaft Ball Bearing Thrust (steel) (2)
WA-14-D	Washer, Shutter Shaft Spring Thrust
WA-18-D	Washer, Ball Bearing Thrust (fiber)
C1-D-55	DOUBLE SHUTTER INTERMEDIATE BRACKET, BALL BEARING AND GEAR ASSEMBLY
C1-D-53	Double Shutter Bracket and Ball Bearing Assembly
BG-9-D	Bearing, Shutter Shaft Reverse Gear Ball
BG-10-D	Bearing, Intermediate Shutter Shaft Ball (2)
BR-16-D	Bracket, Double Shutter (large)
CL-10-D	Collar, Reverse Shutter
CL-35-D	Collar, Intermediate Ball Bearing Tension
CU-22-D	Cup, Oil
GR-7-D	Gear, Shutter Shaft
GR-13-D	Gear, Double Reverse Shutter (steel)
GR-14-D	Gear, Double Shutter Intermediate (fiber)
SC-79-A	Screw, Shutter Shaft Inner Bracket (4)

ORDER BY PART NUMBER

PART NO.	DESCRIPTION
C1-D-55	DOUBLE SHUTTER INTERMEDIATE BRACKET BALL BEARING AND GEAR ASSEMBLY (Continued)
SC-81-D	Screw, Shutter Shaft Gear Fastening
SC-82-BB	Screw, Intermediate Shutter Shaft Ball Bearing Retaining (3)
SC-89-D	Screw, Intermediate Shutter Shaft Collar and Reverse Gear Fastening (2)
SC-131-D	Screw, Reverse Double Shutter Collar and Ball Bearing Retaining (5)
SG-86-D	Spring, Intermediate Shaft Ball Bearing Tension
ST-19-D	Shaft, Intermediate Shutter
WA-4-G	Washer, Intermediate Drive Gear Thrust (fiber) (2)
WA-5-D	Washer, Intermediate Shutter Shaft Ball Bearing Thrust (fiber) (2)
WA-9-G	Washer, Intermediate Drive Gear Thrust (steel) (2)
WA-17-D	Washer, Double Shutter Thrust (steel) (4)
C1-D-58	DOUBLE SHUTTER BLADE AND DRAFT BLADE ASSEMBLY
BD-26-D	Blade, Shutter Blade Draft (2)
BD-37-D	Blade, Double Shutter
SC-94-D	Screw, Shutter Blade Draft Blade (6)
PN-24-A	Pin, Shutter Bracket Locating (inner)
PN-28-A	Pin, Shutter Bracket Locating (outer)
SC-79-A	Screw, Shutter Shaft Bracket Fastening (6)
SC-90-A	Screw, Shutter Guard Mounting (3)
C1-D-59	REVERSE DOUBLE SHUTTER BLADE AND DRAFT BLADE ASSEMBLY
BD-26-D	Blade, Shutter Blade Draft (2)
BD-38-D	Blade, Reverse Double Shutter
SC-94-D	Screw, Shutter Blade Draft Blade (6)
C1-D-60	AUTOMATIC FIRE SHUTTER ASSEMBLY
C1-D-62	Fire Shutter Arm and Reflector Assembly
C1-D-63	Fire Shutter Crank and Stud Assembly
BG-17-D	Bearing, Fire Shutter Dowser
SC-133-D	Screw, Fire Shutter Arm Fastening (2)
SC-79-A	Screw, Fire Shutter Assembly Fastening (2)
C1-D-61	FIRE SHUTTER ARM AND BUSHING ASSEMBLY
AR-5-D	Arm, Fire Shutter *
BU-19-D	Bushing, Fire Shutter *
RV-11-D	Rivets, Fire Shutter Fastening (2)
SR-22-D	Shutter, Fire *
C1-D-62	FIRE SHUTTER ARM AND REFLECTOR ASSEMBLY
C1-D-61	Fire Shutter Arm and Bushing Assembly
RE-9-D	Reflector, Fire Shutter
SC-96-D	Screw, Fire Shutter Reflector Fastening (2)
C1-D-63	FIRE SHUTTER CRANK SHAFT AND STUD ASSEMBLY
CK-11-D	Crank, Fire Shutter
SC-72-A	Screw, Fire Shutter Weight Fastening
SC-95-D	Screw, Fire Shutter Crank Fastening (2)
SC-97-D	Screw, Fire Shutter Lifting Stud
ST-24-D	Shaft, Fire Shutter
SU-26-D	Stud, Fire Shutter Lifting
WT-8-D	Weight, Fire Shutter

*Parts Not Sold Separately

ORDER BY PART NUMBER

PART NO.	DESCRIPTION
C1-E-10	FILM TRAP ASSEMBLY (Complete)
C1-E-11	Film Trap and Pin Assembly
C1-E-12	Lateral Guide Roller Assembly
GU-16-E	Guide, Lateral (2)
PE-5-E	Plate, Aperture
PT-33-E	Pivot, Lateral Guide Roller (2)
RT-6-E	Retainer, Aperture Plate
SC-59-E	Screw, Film Trap Shoe and Guide Fastening (4)
SC-134-BB	Screw, Lateral Guide Roller Pivot Fastening (2)
SH-15-E	Shoe, Film Trap (2)
C1-E-11	FILM TRAP AND PIN ASSEMBLY
PN-14-E	Pin, Aperture Stop
TP-1-E	Trap, Film
C1-E-12	LATERAL GUIDE ROLLER ASSEMBLY
NU-12-E	Nut, Lateral Guide Roller
RO-14-E	Roller, Lateral Guide (long)
RO-16-E	Roller, Lateral Guide (short)
SG-124-E	Spring, Lateral Guide Roller Tension
PN-27-A	Pin, Film Trap Locating (2)
SC-79-A	Screw, Film Trap Mounting (3)
C1-E-20	FILM GATE ASSEMBLY
C1-E-21	Film Gate Plate and Stud Assembly
LE-2-E	Lever, Film Gate Upper Pad
LE-5-E	Lever, Film Gate Lower Pad
NU-2-E	Nut, Film Gate Pad Spring (2)
PA-1-E	Pad, Film Gate (outer top)
PA-8-E	Pad, Film Gate Bottom (2)
PA-9-E	Pad, Film Gate (inner top)
PE-42-E	Plate, Film Stabilizing
SA-30-E	Spacer, Film Gate (upper)
SA-35-E	Spacer, Film Gate (lower)
SC-55-E	Screw, Upper Pad Lever Pivot
SC-56-E	Screw, Lower Pad Lever Pivot
SC-57-E	Screw, Film Pad Fastening (4)
SC-83-E	Screw, Film Gate Support Fastening (2)
SG-34-E	Spring, Upper Film Gate Pad
SG-52-E	Spring, Lower Film Gate Pad
SU-28-E	Stud, Upper Film Gate Tension
SU-29-E	Stud, Lower Film Gate Tension
C1-E-21	FILM GATE PLATE AND STUD ASSEMBLY
PE-7-E	Plate, Film Gate *
SU-145-E	Stud, Film Gate Locating (2) *

*Parts Not Sold Separately

ORDER BY PART NUMBER

PART NO.	DESCRIPTION
C1-G-10	MAIN DRIVE ASSEMBLY
BG-6-G	Bearing, Main Drive Ball (2)
GR-8-G	Gear, Main Drive
PY-6-G	Pulley, Main Drive
SC-32-G	Screw, Main Drive Pulley Set (pointed) (2)
SC-47-G	Screw, Main Drive Gear Set (2)
SC-147-G	Screw, Main Drive Pulley Set (flat) (2)
SV-6-G	Sleeve, Main Drive Gear
WA-4-G	Washer, Main Drive Gear Thrust (fiber) (2)
WA-9-G	Washer, Main Drive Gear Thrust (steel) (2)
RT-2-G	Retainer, Main Drive
SC-127-D	Screw, Main Drive Ball Bearing Retaining (3)
SC-137-C	Screw, Main Drive Retainer Fastening
C1-G-21	VERTICAL SHAFT BALL BEARING AND BRACKET ASSEMBLY (upper)
BG-9-D	Bearing, Vertical Shaft Ball
BR-1-G	Bracket, Vertical Shaft Upper Ball Bearing
SC-127-D	Screw, Vertical Shaft Ball Bearing Retaining (3)
C1-G-22	GOVERNOR WEIGHT ASSEMBLY
HO-3-G	Holder, Governor Weight Lower Link
HO-4-G	Holder, Governor Weight Upper Link
LI-3-G	Link, Governor Weight (4)
SC-95-D	Screw, Governor Weight Link Holder Fastening
SC-135-C	Screw, Governor Weight Link Pivot (short) (4)
SC-136-G	Screw, Governor Weight Link Pivot (long) (4)
SV-42-G	Sleeve, Governor Weight Stop
WT-6-G	Weight, Governor (2)
C1-G-23	VERTICAL INTERMITTENT DRIVE BEARING ASSEMBLY
BG-6-G	Bearing, Intermittent Drive Gear Ball
BR-3-G	Bracket, Intermittent Drive Gear Ball Bearing
SC-127-D	Screw, Intermittent Drive Gear Ball Bearing Retaining (3)
C1-G-24	VERTICAL INTERMITTENT DRIVE GEAR NUT ASSEMBLY
NU-1-G	Nut, Vertical Shaft Intermittent Drive Gear *
PG-13-G	Plug, Vertical Shaft Intermittent Drive Gear Nut (2)
SC-63-G	Screw, Vertical Shaft Intermittent Drive Gear Nut (2)
C1-G-30	VERTICAL SHAFT AND GOVERNOR ASSEMBLY
C1-G-21	Vertical Shaft Ball Bearing and Bracket Assembly (upper)
C1-G-22	Governor Weight Assembly
C1-G-23	Vertical Intermittent Drive Ball Bearing Assembly
C1-G-24	Vertical Intermittent Drive Gear Nut Assembly
C1-G-31	Vertical Shaft Ball Bearing and Bracket Assembly (lower)
CL-13-D	Collar, Vertical Shaft Thrust
CL-28-G	Collar, Lower Vertical Shaft Ball Bearing Protecting
GR-4-G	Gear, Vertical Shaft Driving
GR-5-G	Gear, Vertical Shaft Sprocket Drive (2)
GR-9-G	Gear, Vertical Shaft Intermittent Drive
GR-11-G	Gear, Vertical Shaft Shutter Drive
KY-15-G	Key, Vertical Shaft Intermittent Drive Gear (2)
SC-18-G	Screw, Vertical Shaft Shutter Drive Gear
SC-81-BB	Screw, Collar and Gear Fastening (4)
ST-161-G	Shaft, Vertical (includes 2 KY-15-G)
WA-3-G	Washer, Vertical Shaft Ball Bearing Thrust Collar (fiber) (3)
WA-4-G	Washer, Intermittent Drive Gear Thrust (fiber) (2)
WA-9-G	Washer, Intermittent Drive Gear Thrust (steel) (2)
WA-10-G	Washer, Vertical Shaft Ball Bearing Thrust Collar (steel) (2)
WA-14-D	Washer, Vertical Shaft Drive Gear Spring Thrust (2)

*Parts Not Sold Separately

ORDER BY PART NUMBER

PART NO.	DESCRIPTION
C1-G-31 BG-9-D BR-20-G SC-127-D	VERTICAL SHAFT BALL BEARING AND BRACKET ASSEMBLY (lower) Bearing, Vertical Shaft Ball Bracket, Vertical Shaft Lower Ball Bearing Screw, Vertical Shaft Ball Bearing Retaining (3)
PN-21-A SC-143-A	Pin, Vertical Shaft Bracket Locating (2) Screw, Vertical Shaft Bracket Fastening (4)
CONVERSION PARTS FOR USE WITH WESTERN ELECTRIC "D" SPEC. REPRODUCER	
C1-T-10 C1-T-11 C1-T-12	Running Drive Nut and Washer Assembly Sound Guide Roller Assembly
RUNNING DRIVE NUT AND WASHER ASSEMBLY	
C1-T-11 NU-3-T PG-44-T SC-23-D WA-2-T	Nut, Running Drive Plug, Running Drive Nut Screw Screw, Running Drive Nut Washer, Running Drive
SOUND GUIDE ROLLER ASSEMBLY	
C1-T-12 RO-15-C RT-8-T SC-127-D SU-53-T	Roller, Pad Retainer Ball Bearing (special) Screw, Pad Roller Retaining Stud, Pad Roller
CONVERSION PARTS FOR WESTERN ELECTRIC No. 209 and No. 211 REPRODUCERS	
C1-T-20 C1-T-12 C1-T-21 C1-T-22	Sound Guide Roller Assembly Lower Pad Roller Arm Assembly Lower Sprocket Stripper Assembly
LOWER PAD ROLLER ARM ASSEMBLY	
C1-T-21 C1-C-13 C1-C-21 AR-6-T BL-18-C NU-8-C RO-15-C SC-87-C SC-88-C SG-21-C	Pad Roller Stud Knob and Bushing Assembly Pad Roller Shaft and Knob Assembly Arm, Lower Pad Roller Ball, Pad Roller Bearing (2) Nut, Pad Roller Stop Roller, Pad Screw, Pad Roller Stop Screw, Pad Roller Shaft Fastening Spring, Pad Roller (2)
LOWER SPROCKET STRIPPER ASSEMBLY	
C1-T-22 SC-129-T SP-93-T	Screw, Stripper Stripper
CONVERSION PARTS FOR WESTERN ELECTRIC No. 208 REPRODUCERS	
C1-T-30 C1-T-12 C1-T-31 CR-8-T SC-113-A	Sound Guide Roller Assembly Non-operating Side Door Assembly Cover, Non-operating Side Screw, Non-operating Side Cover Fastening (2)

ORDER BY PART NUMBER

PART NO.	DESCRIPTION
CI-T-31	NON-OPERATING SIDE DOOR ASSEMBLY FOR WESTERN ELECTRIC No. 208 REPRODUCERS
CI-A-11	Door Hinge and Pin Assembly (2)
CI-A-15	Door Lock Spring Assembly
DO-5-T	Door, Non-operating Side
KN-8-A	Knob, Door
LI-7-A	Link, Door Stop
SB-60-A	Stop, Door Closing (felt) (2)
SC-70-A	Screw, Door Hinge Mounting (6)
SC-110-A	Screw, Door Stop Link
SC-111-A	Screw, Door Knob Fastening (2)
SC-123-A	Screw, Door Lock Spring (2)
CI-T-40	CONVERSION PARTS FOR WESTERN ELECTRIC UNIVERSAL BASE REPRODUCERS
CI-T-12	Sound Guide Roller Assembly
CI-T-41	Main Drive Sleeve Coupling Assembly
SC-119-T	Screw, Main Drive Gear Fastening (2)
CI-T-41	MAIN DRIVE SLEEVE COUPLING ASSEMBLY
BU-7-G	Bushing, Main Drive Sleeve Coupling *
CG-23-G	Coupling, Main Drive Sleeve *
CI-T-60	CONVERSION PARTS REQUIRED FOR VERY LONG LENSES
CI-T-61	Focusing Screw and Collar Assembly (special)
CI-T-62	Front Lens Carrier Assembly
KN-3-A	Knob, Lens Focusing
NU-5-A	Nut, Lens Focusing Screw Stop (2)
RD-19-T	Rod, Lens Carrier Guide (long) (2)
SC-72-A	Screw, Lens Focusing Knob
CI-T-61	FOCUSING SCREW AND COLLAR ASSEMBLY FOR VERY LONG LENSES
CL-25-A	Collar, Focusing Screw Thrust
PN-34-A	Pin, Focusing Screw Thrust Collar
SC-171-T	Screw, Focusing (long)
CI-T-62	FRONT LENS CARRIER ASSEMBLY
CI-A-42	Lens Clamp Screw and Knob Assembly
CA-38-T	Carrier, Front Lens
SC-141-BB	Screw, Guide Rod Fastening (2)
WA-21-A	Washer, Lens Clamp Screw
CI-T-120	CONVERSION PARTS FOR WESTERN ELECTRIC No. 206 REPRODUCERS
CI-T-30	Conversion Parts for Western Electric No. 208 Reproducers
CI-T-121	Pulley and Bracket Assembly
CI-T-121	PULLEY AND BRACKET ASSEMBLY
BR-48-T	Bracket, Take-up Pulley
BU-77-T	Bushing, Take-up Pulley (2)
PY-52-T	Pulley, Take-up Idler (2)
SC-178-T	Screw, Take-up Pulley Mounting (2)
CI-T-130	CONVERSION PARTS FOR R. C. A. No. PS-8 REPRODUCERS
CL-45-T	Collar, Main Drive *
SV-207-T	Sleeve, Main Drive *

*Parts Not Sold Separately