

Film-Tech

The information contained in this Adobe Acrobat pdf file is provided at your own risk and good judgment.

These manuals are designed to facilitate the exchange of information related to cinema projection and film handling, with no warranties nor obligations from the authors, for qualified field service engineers.

If you are not a qualified technician, please make no adjustments to anything you may read about in these Adobe manual downloads

www.film-tech.com

PARTS FOR WENZEL "ACE," SIMPLEX AND KAPLAN PROJECTORS

G.A. McLEOD ENTERPRISES
 THEATRE EQUIPMENT SERVICE, RENTALS
 258 MERTON ST. TORONTO, ONTARIO, CANADA
 M4S 1A7 (416) 465-4626

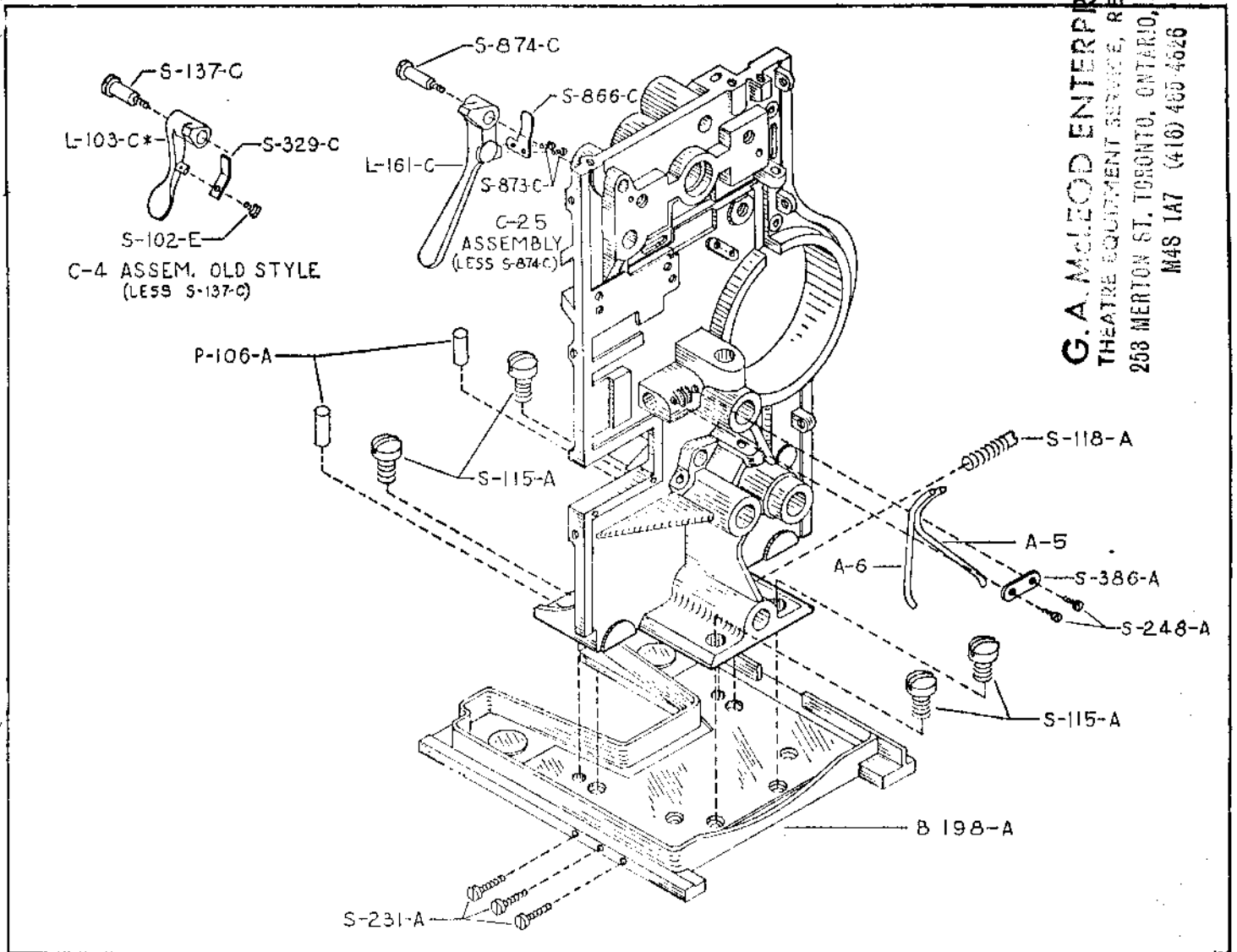

MAIN FRAME AND TRAP DOOR LEVER ASSEMBLY

Number	Description	Number	Description
C-4	FILM TRAP LEVER ASSEMBLY		
S-102-E	Film trap door trip lever spring screw.	A-5	Main drive shaft oil tube
L-103-C	Film trap door trip lever.*	A-6	Lower sprocket shaft oil tube
S-329-C	Film trap door trip lever spring	P-106-A	Base dowel pin
C-25	FILM TRAP LEVER ASSEMBLY (NEW STYLE)	S-115-A	Center frame fastening screws
L-161-C	Film trap door trip lever.*	S-118-A	Motor drive pinion shaft set screw
S-866-C	Film trap door trip lever spring	S-137-C	Film trap door trip lever pivot screw
S-873-C	Film trap door trip lever spring screw (2)	B-198-A	Center frame base
		S-231-A	Base oil drain screws (3)
		S-248-A	Oil tube clamp fastening screws (2)
		S-386-A	Oil tube clamp
		S-874-C	Film trap door trip lever pivot screw

PLEASE ORDER BY NUMBER

*THESE PARTS ARE NOT SOLD SEPARATELY

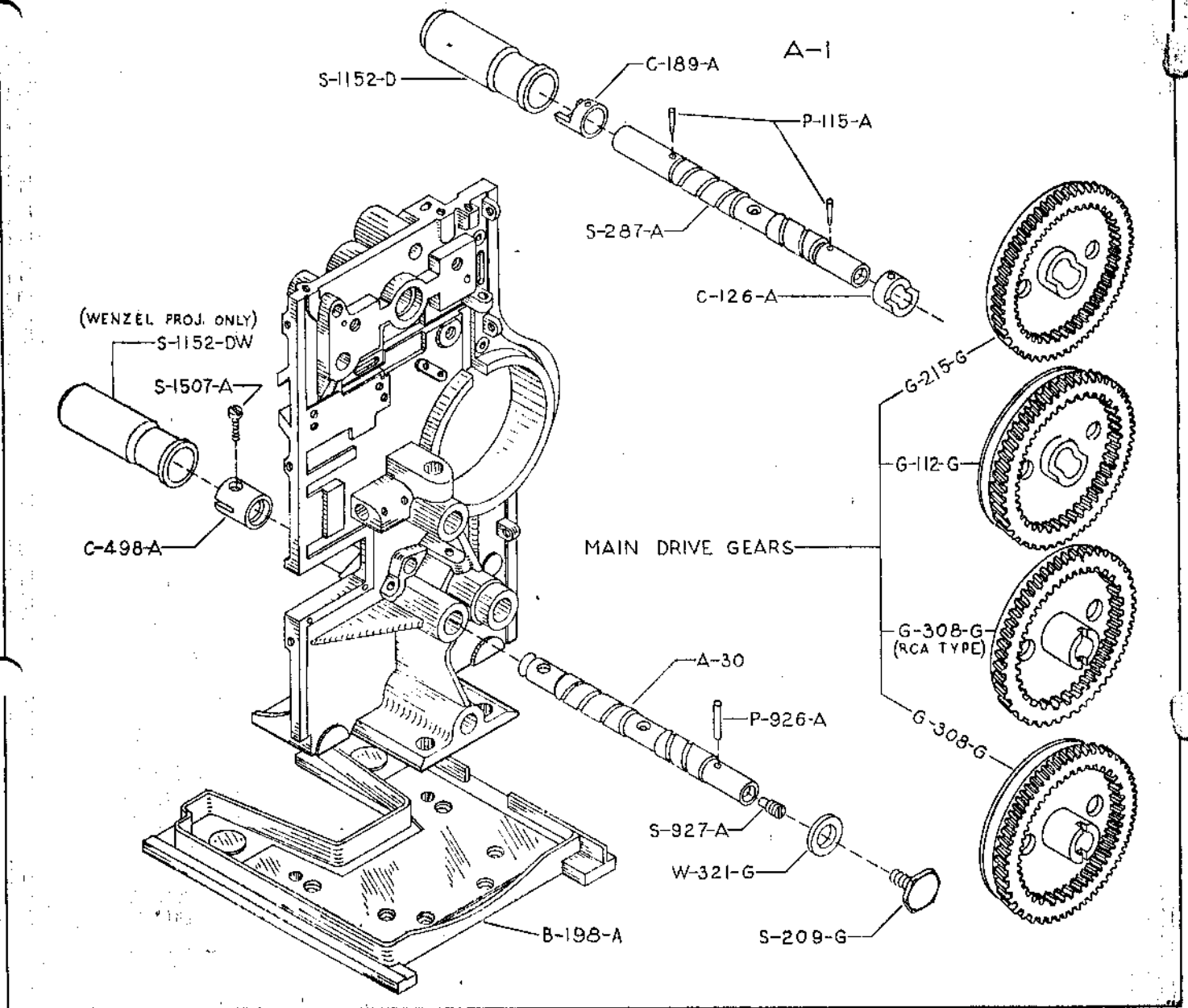

MAIN DRIVE SHAFTS AND GEARS

Number	Description
A-1	HANDLE SHAFT AND COLLAR
P-115-A	Handle shaft driving collar pin (2)
C-126-A	Main driving gear clutch
C-189-A	Handle shaft driving collar
S-287-A	Handle shaft
A-30	MAIN DRIVE SHAFT ASSEMBLY
A-30-A	Main drive shaft (only)
W-321-G	Main drive gear washer
C-498-A	Main drive shaft collar
P-926-A	Main gear driving pin
S-927-A	Gear driving pin stop screw
S-1507-A	Main drive shaft collar screw

Number	Description
MAIN DRIVE GEARS	
G-112-G	Main drive gear for A-1 shaft
G-215-G	Main drive gear, (R,C,A, style) for A-1 shaft
G-308-G	Main drive gear for A-30 shaft
G-308-G	(R, C, A, Type) Main drive gear for A-30 shaft

PARTS	
S-209-G	Main drive gear retaining screw
B-198-A	Center frame base
S-1152-D	Main drive shaft oil shield
S-1152-DW	Main drive shaft oil shield (Wenzel Projector only)

PLEASE ORDER BY NUMBER

*THESE PARTS ARE NOT SOLD SEPARATELY

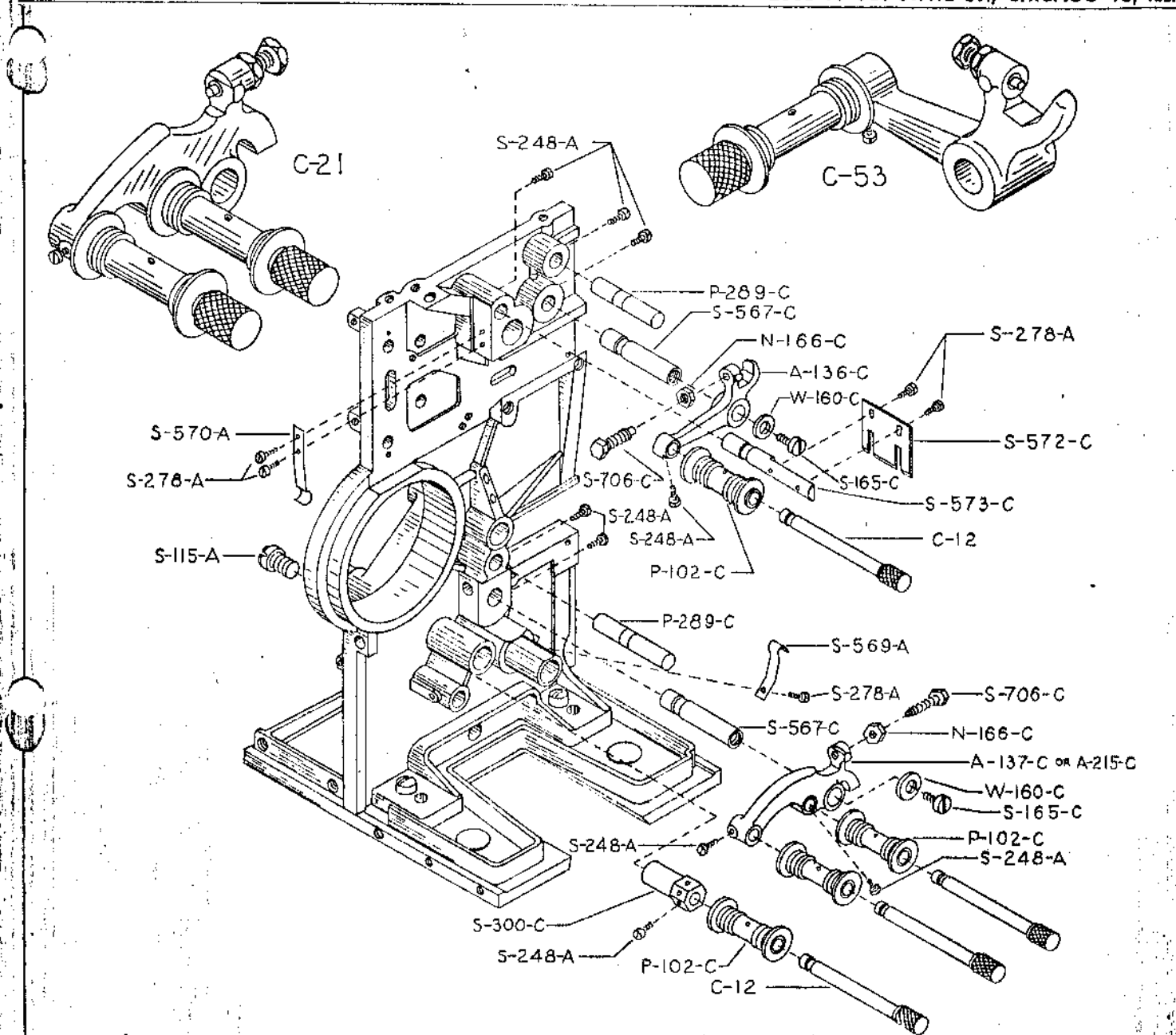

PAD ROLLERS, PAD ROLLER ARMS AND ASSOCIATED PARTS

Number	Description
C-12	PAD ROLLER STUD AND KNOB
C-21	LOWER PAD ROLLER ARM COMPLETE
C-12 - C-16	Pad roller stud & knob (2)
P-102-C	Pad roller (2)
A-137-C - A-215-C	Lower pad roller arm
W-160-C	Pad roller arm stud washer
S-165-C	Pad roller arm stud washer screw
N-166-C	Pad roller arm nut
S-248-A	Pad roller stud screw (2)
S-567-C	Pad roller arm stud
S-706-C	Pad roller arm screw
53	UPPER PAD ROLLER ARM COMPLETE
C-12	Pad roller stud and knob
P-102-C	Pad roller
A-136-C	Upper pad roller arm
W-160-C	Pad roller arm stud washer

Number	Description
S-165-C	Pad roller arm stud washer screw
N-166-C	Pad roller arm nut
S-248-A	Pad roller stud and knob holding screw
S-567-C	Pad roller arm stud
S-706-C	Pad roller arm screw

PARTS

S-115-A	Movietone stud fastening screw
S-193-C	Sprocket roller arm pivot screw
S-248-A	Stud holding screw
S-278-A	Pad roller arm tension spring fasten'g screw
P-289-C	Roller arm stop pin
S-300-C	Movietone stud
S-569-A	Lower sprocket roller arm spring
S-570-A	Upper sprocket roller arm spring
S-572-C	Upper and lower sprocket film stripper
S-573-C	Upper and lower sprocket film stripper stud

PLEASE ORDER BY NUMBER

*THESE PARTS ARE NOT SOLD SEPARATELY

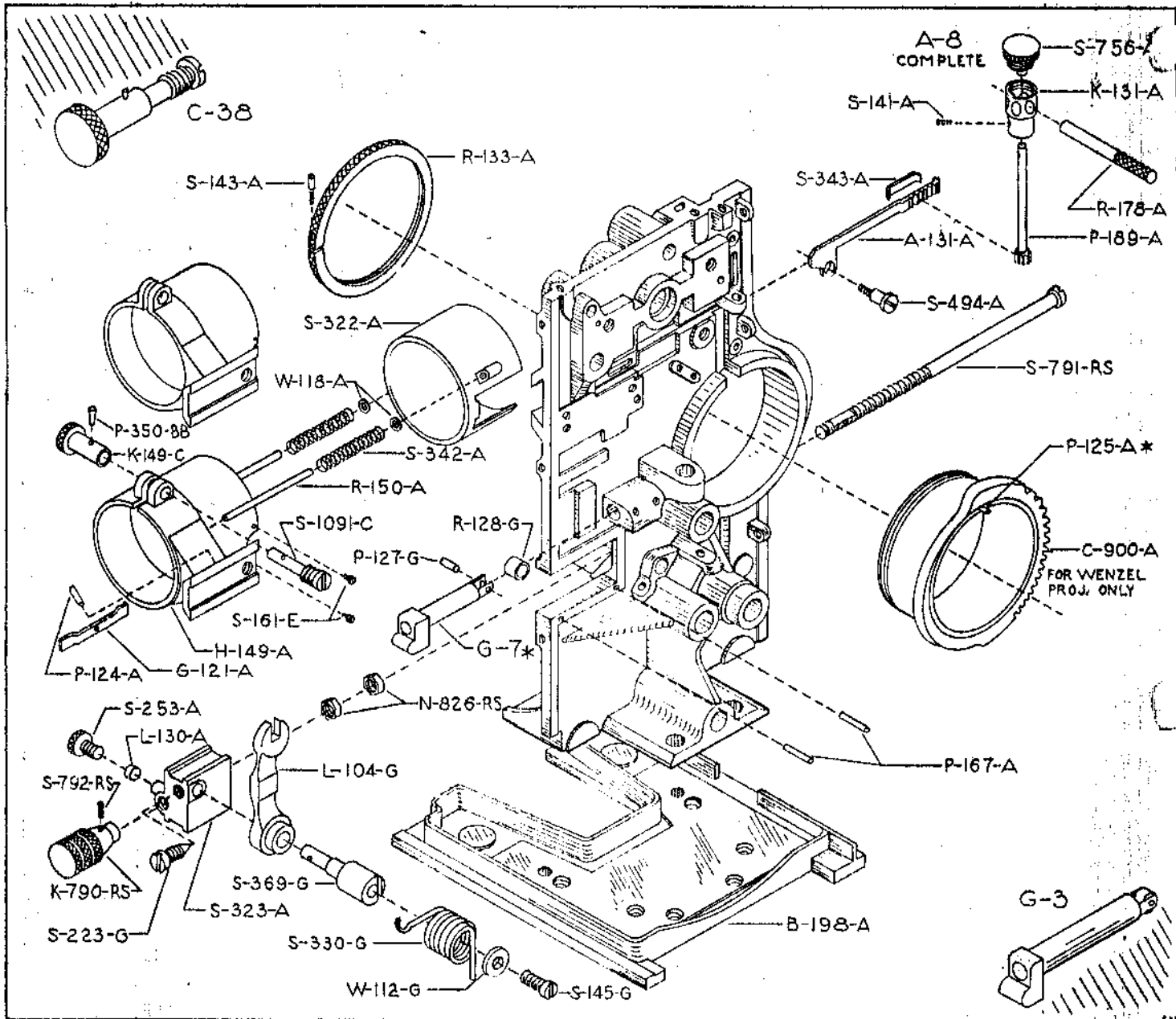

FRAMING AND FOCUSING DEVICES

Number	Description	Number	Description
G-3	FRAMING SLIDE ASSEMBLY	S-161-E	Projecting lens holder slide stop screw (2)
G-7	Framing arm and shoe assembly *	S-322-A	Projecting lens holder slide
P-127-G	Framing slide arm roller pin	S-342-A	Projecting lens holder slide guide rod spring (2)
R-128-G	Framing slide arm roller	S-494-A	Focusing rack retaining screw
A-4	PROJECTOR LENS HOLDER AND SLIDE	G-7	FRAMING ARM AND SHOE ASSEMBLY *
C-38	Lens holder clamp knob and screw assembly	A-110-G	Framing arm *
W-118-A	Projector lens holder slide guide rod washer (2)	S-312-G	Framing arm shoe *
P-124-A	Focusing gib pin	A-8	FOCUSING PINION KNOB
H-149-A	Projecting lens holder	K-131-A	Focusing pinion knob
R-150-A	Projecting lens holder slide guide rod (2)	S-141-A	Focusing pinion knob set screw
		R-178-A	Focusing pinion rod
		S-756-A	Focusing pinion screw

PLEASE ORDER BY NUMBER

*THESE PARTS ARE NOT SOLD SEPARATELY

Number	Description	Number	Description
S-14 SHUTTER ADJUSTING ASSEMBLY		L-130-A	Shutter adjusting slide lock screw brass plug
K-790-RS	Shutter adjusting screw knob	A-131-A	Focusing rack arm
S-791-RS	Shutter adjusting screw	R-133-A	Framing cam adjusting ring
S-792-RS	Shutter adjusting knob set screw	S-143-A	Framing cam adjusting ring screw
N-826-RS	Nut for shutter adjusting screw (2)	S-145-G	Shutter adjusting slide lever stud spring retaining screw
C-38 CLAMP KNOB AND SCREW FOR LENS ALIGNER		HW-149-A	Projecting lens holder for oversize lens
K-149-C	Clamp knob	P-167-A	Shutter adjusting slide stop pin (2)
P-350-BB	Clamp knob pin	P-189-A	Focusing pinion
S-1091-C	Clamp knob screw	B-198-A	Center frame base
		S-223-G	Shutter adjusting slide lever stud set screw
		S-253-A	Shutter adjusting slide lock screw
		S-323-A	Shutter adjusting slide
		S-330-G	Shutter adjusting slide lever spring
		S-343-A	Rack arm friction spring
		S-369-G	Shutter adjusting lever stud
		C-900-A	Framing cam (for Wenzel Projector only)

PARTS

L-104-G	Shutter adjusting slide lever
W-112-G	Shutter adjusting slide lever retaining spring washer
G-121-A	Focusing slide gib
P-125-A	Framing cam locating pin *

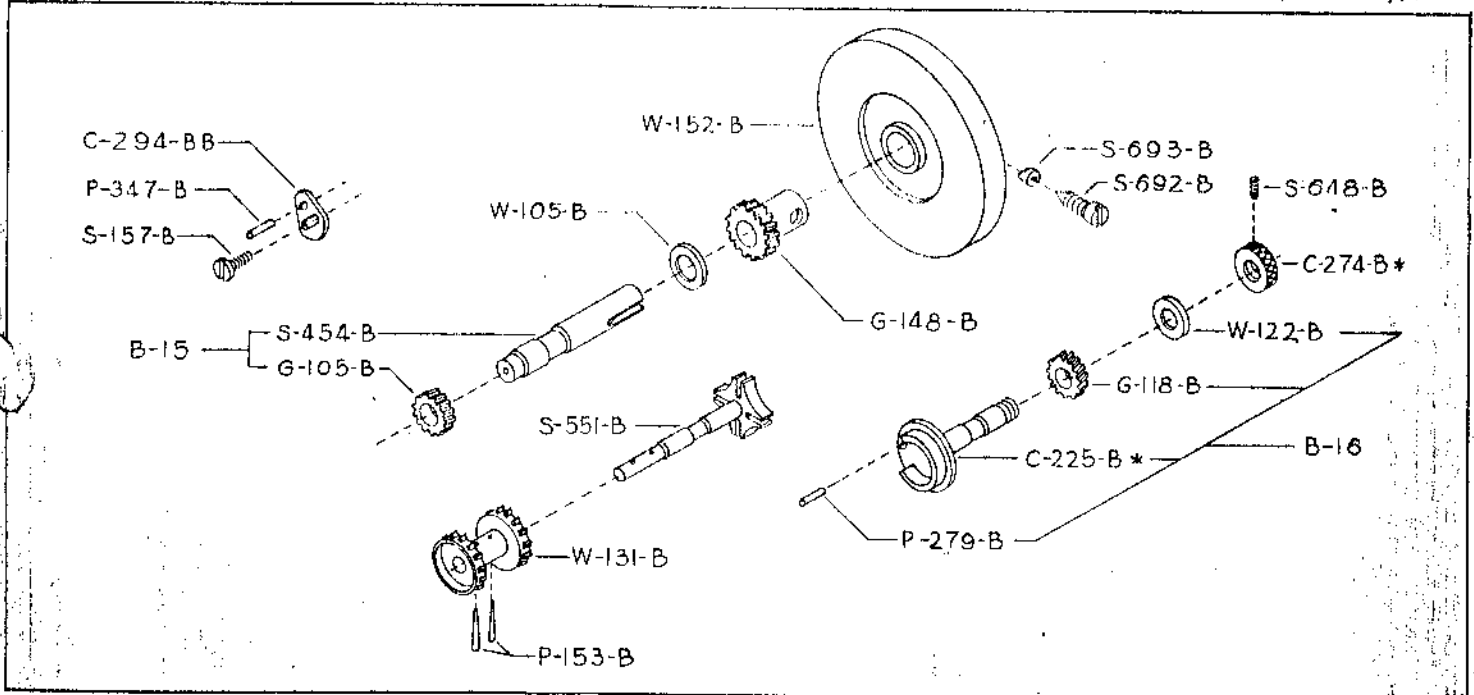

SINGLE BEARING INTERMITTENT PARTS

Number	Description	Number	Description
B-11 STAR WHEEL AND INTERMITTENT SPROCKET		B-16 STAR WHEEL CAM ASSEMBLY COMPLETE	
W-131-B	Intermittent sprocket hardened	B-19	Cam shaft collar and screw
P-153-B	Intermittent sprocket taper pin (2)	G-118-B	Star wheel cam gear
S-551-B	Star wheel and shaft	W-122-B	Star wheel cam washer
B-14 FLYWHEEL AND GEAR ASSEMBLY		C-225-B	Star wheel cam *
G-148-B	Flywheel gear (includes S-692-B and S-693-B)	P-279-B	Star wheel cam pin
W-152-B	Flywheel	B-19 CAM SHAFT COLLAR AND SCREW	
S-692-B	Flywheel set screw (new style)	C-274-B	Cam collar *
S-693-B	Flywheel set screw shoe	S-648-B	Cam collar shaft screw
B-15 FLYWHEEL SHAFT AND GEAR ASSEMBLY			
G-105-B	Flywheel shaft gear		
S-454-B	Flywheel shaft		
		PARTS	
		W-105-B	Flywheel washer
		S-125-B	Eccentric bushing screw (2)
		S-157-B	Intermittent case cover lock screw (2)
		C-294-BB	Intermittent case cover clamp (2)
		P-347-B	Intermittent case cover pin (2)

PLEASE ORDER BY NUMBER

*THESE PARTS ARE NOT SOLD SEPARATELY

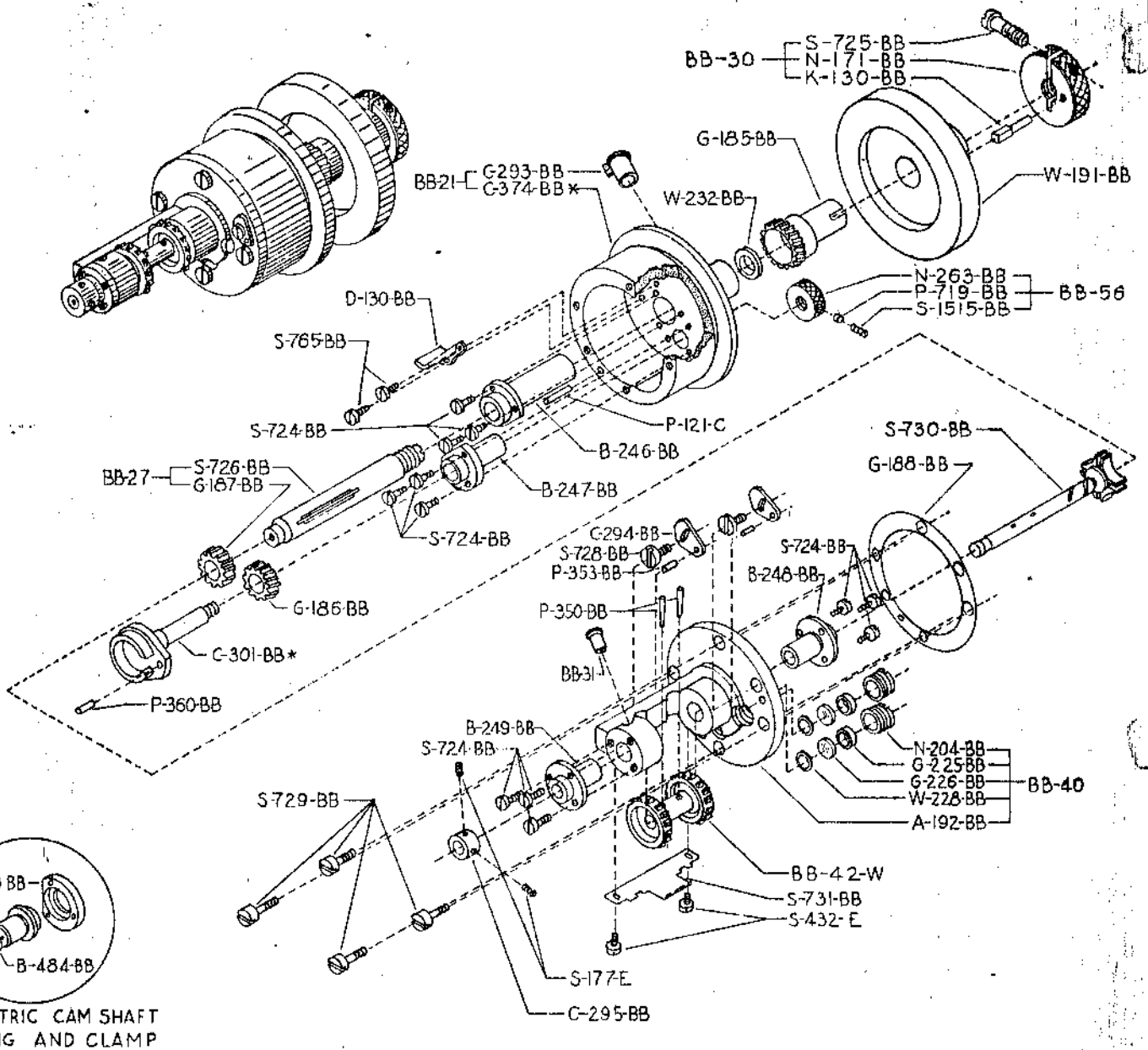

**DOUBLE BEARING INTERMITTENT MOVEMENTS FOR
"ACE" SIMPLEX AND KAPLAN PROJECTORS**

Number	Description	Number	Description
"BB" DOUBLE BEARING INTERMITTENT MOVEMENT COMPLETE, "BB" ASSEMBLIES		B-249-BB	Star wheel shaft outer bearing (oilite)
BB-21 INTERMITTENT CASE ASSEMBLY		C-295-BB	Star wheel shaft collar
P-121-C	Intermittent adjusting pivot	P-353-BB	Case retaining clamp pivot (2)
C-293-BB	Intermittent oil cup	S-432-E	Stripper screw (2)
C-374-BB	Intermittent case *	S-724-BB	Bearing screw (6)
BB-22 INTERMITTENT CASE COVER AND BEARING ASSEMBLY		S-731-BB	Intermittent film stripper
BB-40	Oil tight cover assembly	BB-26 STAR WHEEL SHAFT AND SPROCKET ASSEMBLY	
S-177-E	Collar set screw (2)	BB-42-W	Intermittent sprocket hardened and ground
B-248-BB	Star wheel shaft inner bearing	P-350-BB	Intermittent sprocket pin (2)
		S-730-BB	Star wheel and shaft

PLEASE ORDER BY NUMBER

*THESE PARTS ARE NOT SOLD SEPARATELY

DOUBLE BEARING INTERMITTENT MOVEMENTS FOR "ACE" SIMPLEX AND KAPLAN PROJECTORS

Number	Description	Number	Description
BB-27	FLY WHEEL SHAFT AND GEAR ASSEMBLY	BB-52	INTERMITTENT CASE COVER AND BEARINGS (includes BB-40)
	G-187-BB Fly wheel shaft gear	B-323-BB	Star wheel shaft inner bearing
	S-726-BB Fly wheel shaft	B-482-BB	Star wheel shaft outer bearing
BB-28	FLY WHEEL AND GEAR ASSEMBLY	C-295-BB	Star wheel shaft collar
	G-185-BB Fly wheel gear	S-177-E	Collar set screw (2)
	W-191-BB Fly wheel	S-432-E	Stripper screw (2)
BB-29	FLY WHEEL LOCK NUT AND SCREW	S-724-BB	Bearing screw (6)
	N-171-BB Fly wheel lock nut	S-731-BB	Film Stripper
	S-725-BB Fly wheel lock nut screw		
BB-30	FLY WHEEL LOCK NUT ASSEMBLY	BB-56	CAM SHAFT ADJUSTING NUT ASSEMBLY
	BB-29 Fly wheel lock nut and screw	N-263-BB	Cam retaining lock nut
	K-130-BB Fly wheel lock key	P-719-BB	Cam retaining nut stop lock
		S-1515-BB	Cam retaining nut lock screw
BB-31	OUTER BEARING OIL CUP COMPLETE		
BB-38	INTERMITTENT CAM ASSEMBLY		"BB" PARTS
	BB-56 Cam shaft adjusting nut assembly	W-227-BB	Oil retaining washer
	G-186-BB Cam gear	D-130-BB	Oil deflector
	C-301-BB Intermittent cam *	G-188-BB	Oil gasket
	P-360-BB Cam pin	G-241-BB	Case cover glass (old style)
BB-40	OIL TIGHT COVER ASSEMBLY	B-246-BB	Fly wheel shaft bearing
	BB-31 Outer bearing oil cup complete	B-247-BB	Cam shaft bearing
	A-192-BB Case cover and bearing arm	C-294-BB	Case retaining clamp (2)
	N-204-BB Oil sight nut (2)	B-484-BB	Cam shaft bearing with C-483-BB clamp
	G-225-BB Case cover glass gasket (2)	S-724-BB	Bearing screw
	G-226-BB Oil sight glass (2)	S-728-BB	Case clamp screw (2)
	W-228-BB Oil sight washer (2)	S-729-BB	Case cover screw (4)
	W-232-BB Fly wheel gear oil retaining washer	S-765-BB	Oil deflector screw (2)

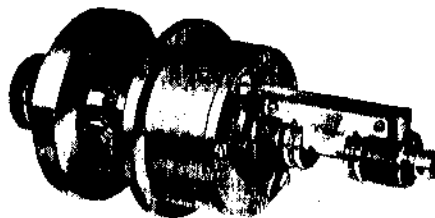

"BB" INTERMITTENT

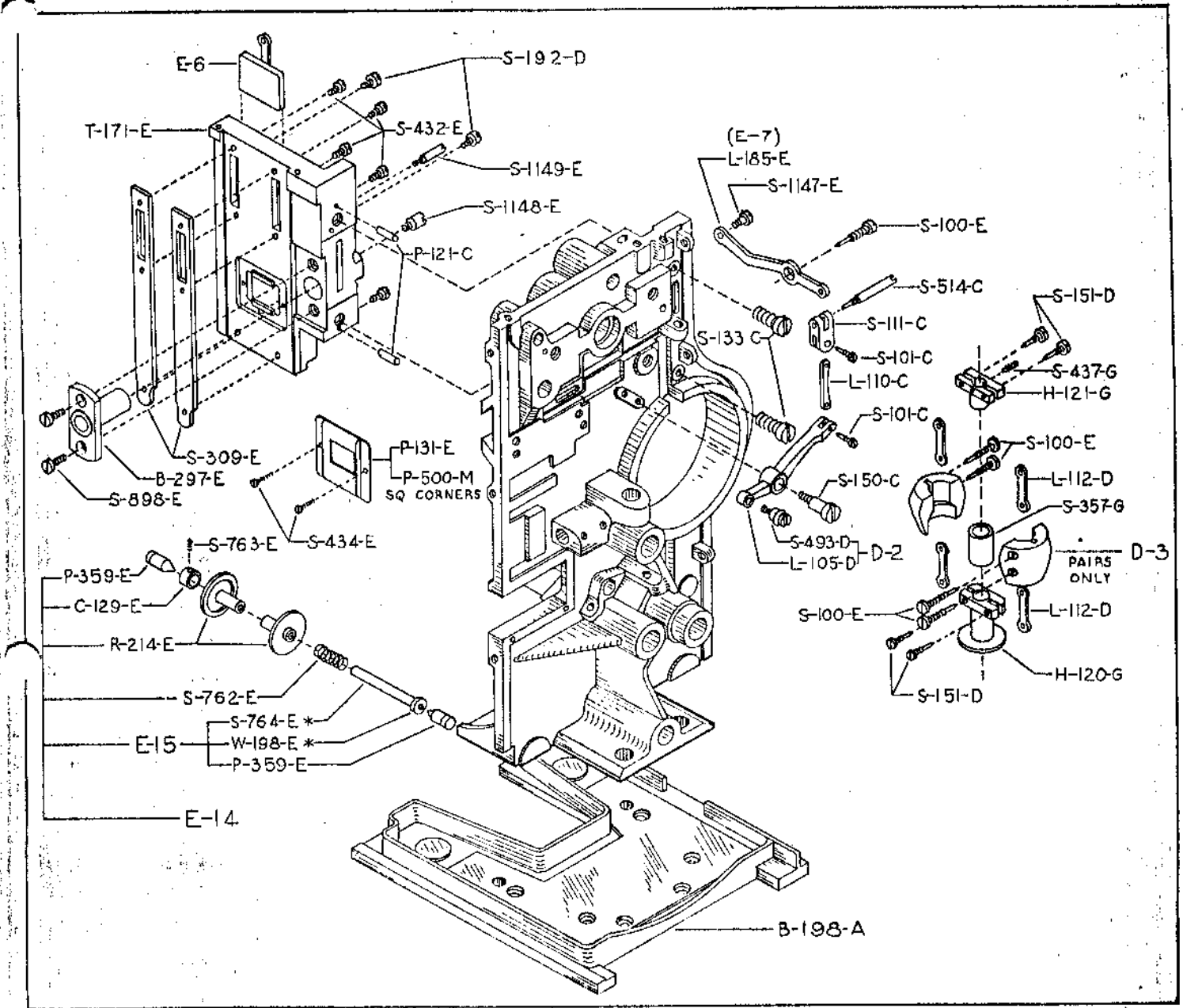

FILM TRAP ASSEMBLY AND AUTOMATIC FIRE SHUTTER DEVICES

"E" FILM TRAP ASSEMBLY COMPLETE (includes E-2 & E-10)

"EW" FILM TRAP ASSEMBLY COMPLETE, SLIP-IN TYPE (includes EW-2 & EW-10)

Number	Description	Number	Description
E-6	Automatic fire shutter assembly	S-309-E	Film trap shoe (2)
E-7	Automatic fire shutter lift lever	B-297-E	Film trap bushing
E-8	Automatic fire shutter and lever assembly	S-432-E	Film trap shoe screw (6)
E-14	Lateral guide roller assembly	S-898-E	Film trap bushing fastening screw (2)
171-E	Cast iron film trap for stationary plate and bushing assembly	S-1148-E	Automatic fire shutter stop screw
S-192-D	Lateral guide roller pivot retaining screw (2)	S-1149-E	Automatic fire shutter lift lever stop screw

PLEASE ORDER BY NUMBER

*THESE PARTS ARE NOT SOLD SEPARATELY

FILM TRAP ASSEMBLY AND AUTOMATIC FIRE SHUTTER DEVICES

Number	Description
E-6	AUTOMATIC FIRE SHUTTER ASSEMBLY
E-7	AUTOMATIC FIRE SHUTTER LIFT LEVER
E-8	AUTOMATIC FIRE SHUTTER AND LEVER ASSEMBLY
E-6	Automatic fire shutter assembly
L-185-E	Automatic fire shutter lift lever
S-1147-E	Automatic fire shutter lift link retaining screw
E-14	LATERAL GUIDE ROLLER ASSEMBLY
E-15	Lateral guide roller shaft and washer assembly
C-129-E	Lateral guide roller shaft collar
R-214-E	Lateral guide roller (2)
S-762-E	Guide roller spring
S-763-E	Lateral guide roller shaft collar screw
E-15	LATERAL GUIDE ROLLER SHAFT AND WASHER ASSEMBLY
W-198-E	Guide roller spring retaining washer *
P-359-E	Guide roller pivot (2)
S-764-E	Lateral guide roller shaft *
T-172-E	CAST IRON FILM TRAP FOR SLIDE IN TYPE ASSEMBLY
T-171-E	CAST IRON FILM TRAP FOR STATIONARY PLATE AND BUSHING ASSEMBLY
S-100-E	Automatic fire shutter lift lever pivot screw
L-185-E	Automatic fire shutter lift lever
B-297-E	Film trap bushing
S-898-E	Film trap bushing fastening screw (2)

Number	Description
PARTS	
P-121-C	Film trap locating pin (2)
P-131-E	Aperture plate for (E-16 trap)
S-133-C	Film trap fastening screw (2)
S-434-E	Aperture plate retaining screw (2)
P-500-M	Aperture plate

AUTOMATIC FIRE SHUTTER DEVICES

D-2	GOVERNOR LIFT LEVER ASSEMBLY
L-105-D	Governor lift lever
S-493-D	Governor lift lever screw
D-3	GOVERNOR WEIGHT AND LINKS ASSEMBLY (In Pairs Only)
S-100-E	Governor weight link screw (4)
L-112-D	Governor weight link (2)
W-126-D	Governor weights (sold in matched pairs only) *
C-9	GOVERNOR LIFT LEVER LINK ASSEMBLY
L-110-C	Governor lift lever link
L-111-C	Governor lift lever connecting link
S-101-C	Governor lift lever connecting link screw

PARTS

H-120-G	Governor lower link holder (specify hardened or soft)
H-121-G	Governor upper link holder
S-150-C	Governor lift lever pivot screw
S-151-D	Governor link holder screw (4)
B-198-A	Center frame base
S-357-G	Governor weight stop
S-437-G	Upper governor link holder set screw
S-514-C	Automatic fire shutter lifting stud

PARTS

L-101-E	Automatic fire shutter lift lever *
T-101-E	Film trap door thimble
S-134-E	Film trap door holding screw
S-310-E	Film trap door shoe left (old style trap gate)
S-311-E	Film trap door shoe left (old style trap gate)
S-327-E	Door holder spring
S-792-D	Fire shutter stop screw
S-787-D	Thumb plate screw

PLEASE ORDER BY NUMBER

15

*THESE PARTS ARE NOT SOLD SEPARATELY

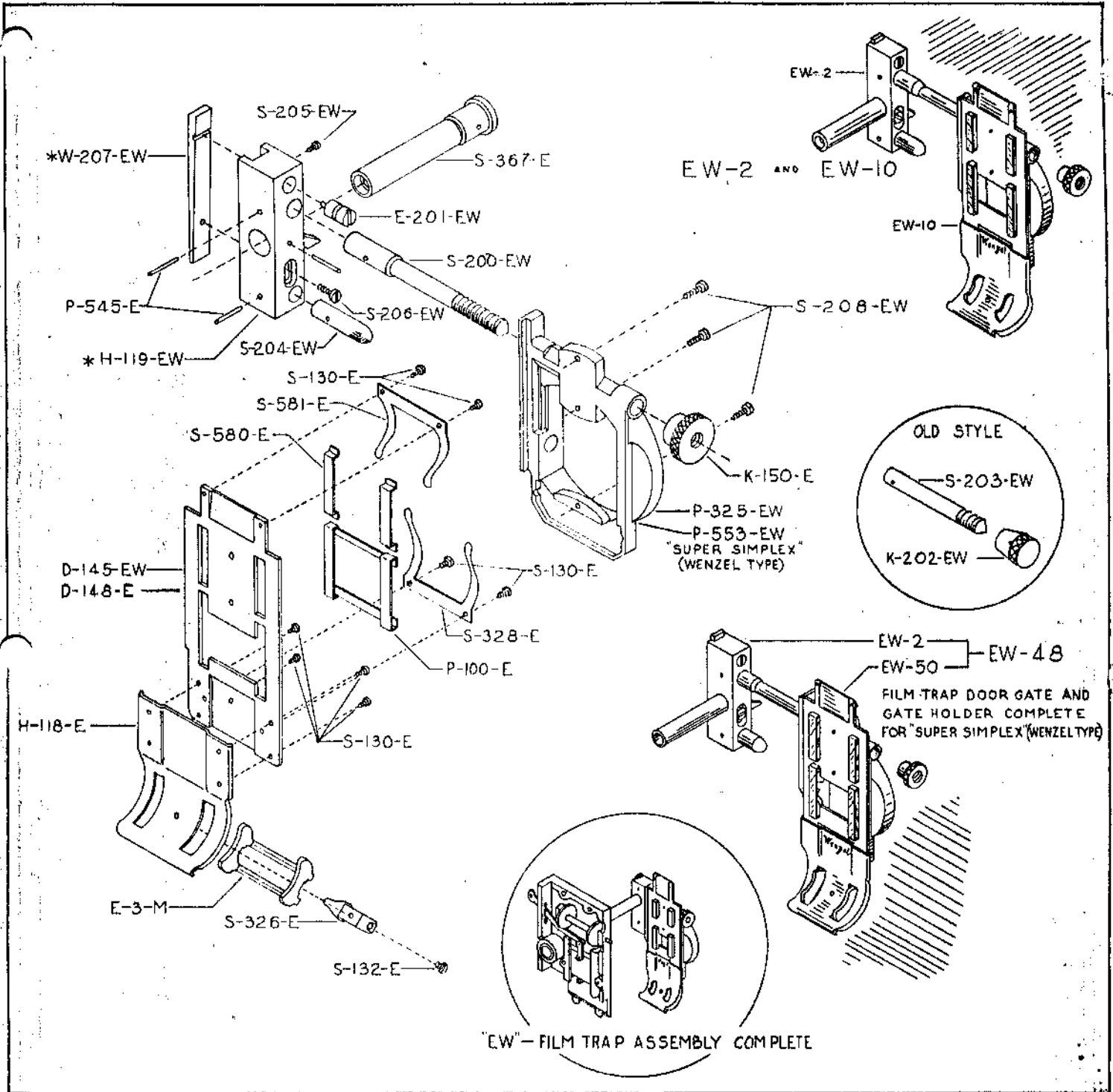

WENZEL FILM TRAP DOOR AND DOOR HOLDER ASSEMBLY
 "EW" WENZEL SLIP IN TYPE TRAP AND GATE ASSEMBLY
 "EW" SUB-ASSEMBLIES

Number	Description
EW-2	DOOR HOLDER ASSEMBLY
H-119-EW	Door holder *
E-201-EW	Eccentric for wedge assembly
K-150-E	Knob for upper gate stud
S-200-EW	Upper stud for gate
S-204-EW	Lower stud for gate

Number	Description
S-205-EW	Screw to lock eccentric
S-206-EW	Screw to lock wedge
W-207-EW	Wedge for door holder adjustment *
S-367-E	Door holder stud
P-545-E	Stud pin (3)

PLEASE ORDER BY NUMBER

*THESE PARTS ARE NOT SOLD SEPARATELY

WENZEL FILM TRAP DOOR AND DOOR HOLDER ASSEMBLY

Number	Description
EW-10	DOUBLE TENSION SLIP IN TYPE FILM TRAP DOOR ASSEMBLY
E-3-M	Film guide (one piece) or E-3 (specify)
P-100-E	Film trap door pad
H-118-E	Film guide holder
S-130-E	Film guide holder screw (8)
S-132-E	Film guide spring fastening screw
D-148-E	} Film trap door
D-145-EW	
S-208-EW	Film protector screw (3)
P-325-EW	Film protector
S-326-E	Film guide retaining spring
S-328-E	Film trap door pad spring
S-580-E	Double tension film trap door shoe (2)
S-581-E	Double tension film trap door shoe spring

EW-48 SLIP IN TYPE FILM TRAP DOOR GATE AND GATE HOLDER COMPLETE FOR SUPER SIMPLEX (WENZEL TYPE)

EW-2 DOOR HOLDER ASSEMBLY

H-119-EW	Door holder *
E-201-EW	Eccentric for wedge assembly

Number	Description
K-150-E	Knob for upper gate stud
S-200-EW	Upper stud for gate
S-204-EW	Lower stud for gate
S-205-EW	Screw to lock eccentric
S-206-EW	Screw to lock wedge
W-207-EW	Wedge for door holder adjustment *
S-367-E	Door holder stud
P-545-E	Stud pin (3)

EW-50 DOUBLE TENSION SLIP IN TYPE FILM TRAP DOOR ASSEMBLY

E-3-M	Film guide or E-3 (specify)
P-100-E	Film trap door pad
H-118-E	Film guide holder
S-130-E	Film guide holder screw (8)
S-132-E	Film guide spring fastening screw
D-148-E	Film trap door
S-208-EW	Film protector screw (3)
P-553-EW	Film protector
S-326-E	Film guide retaining spring
S-328-E	Film trap door pad spring
S-580-E	Double tension film trap door shoe (2)
S-581-E	Double tension film trap door shoe spring

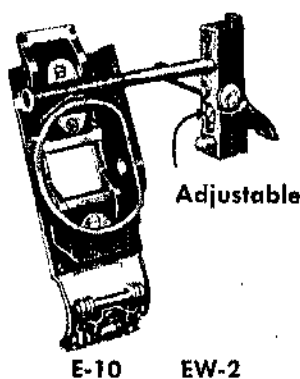

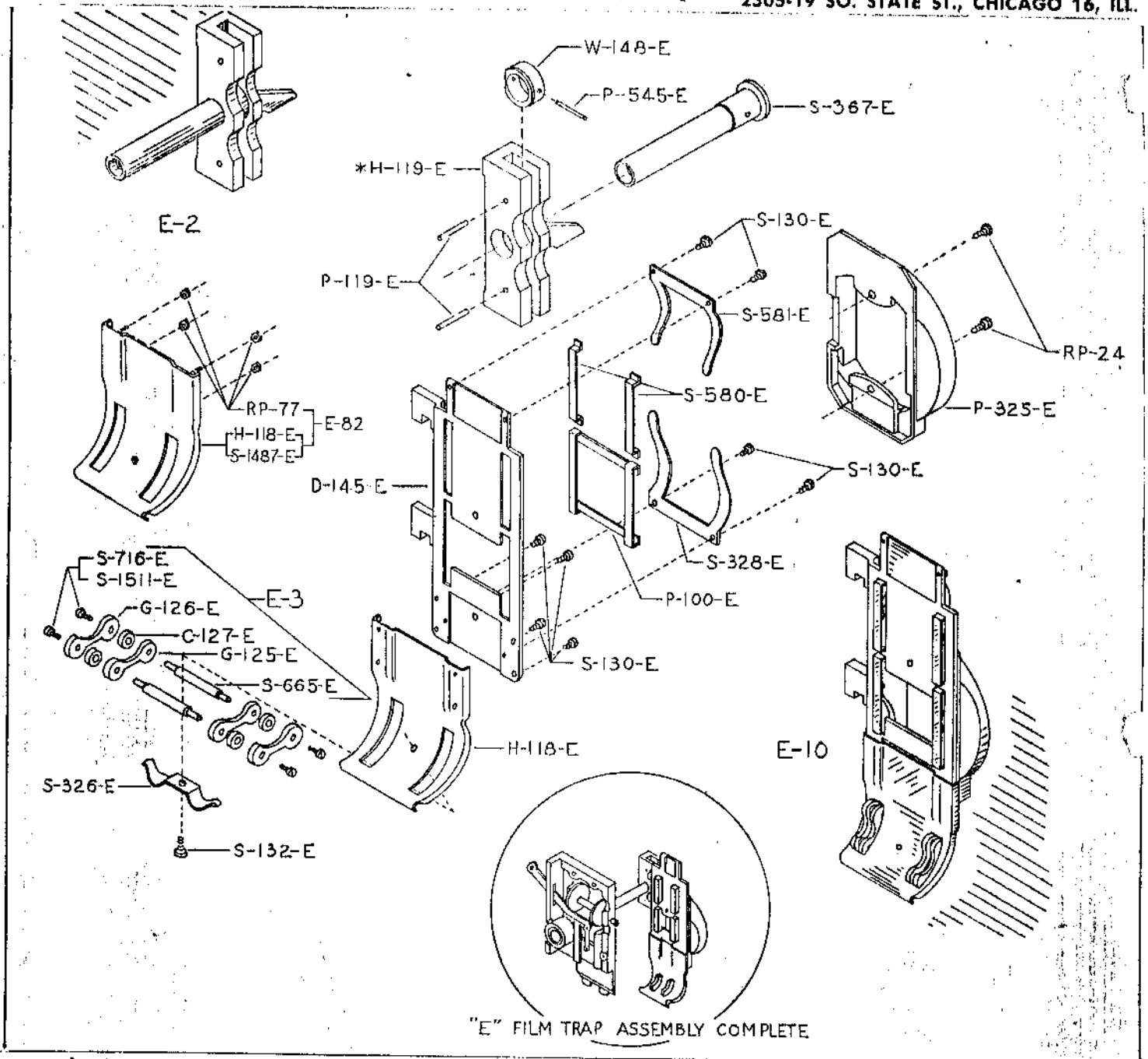

"E" FILM TRAP ASSEMBLY COMPLETE

FILM TRAP DOOR ASSEMBLY AND TRAP DOOR HOLDER ASSEMBLY

"E" FILM TRAP ASSEMBLY COMPLETE INCLUDES E-2 AND E-10

E-2 FILM TRAP DOOR HOLDER AND STUD ASSEMBLY

- H-119-E Door holder *
- P-119-E Door holder pin (2)
- W-148-E Film trap door holder stud spacer
- S-367-E Film trap door holder stud
- P-545-E Film trap door holder stud retaining pin

E-3 INTERMITTENT FILM GUIDE ASSEMBLY

- G-125-E Intermittent film guide (inside) (2)
- G-126-E Intermittent film guide (outside) (2)
- C-127-E Intermittent film guide distance collar (4)
- S-665-E Intermittent film guide stud (2)
- S-716-E-S-1511-E Intermittent film guide screw (4)

E-10 DOUBLE TENSION FILM TRAP DOOR ASSEMBLY (Includes E-3)

PLEASE ORDER BY NUMBER

- RP-24 Film protector fastening screw (2)
 - P-100-E Film trap door pad
 - H-118-E Film guide holder
 - S-130-E Film guide holder screw (8)
 - S-132-E Film guide retaining spring screw
 - D-145-E Film trap door
 - P-325-E Trap door protector
 - S-326-E Film guide retaining spring
 - S-328-E Film trap door pad spring
 - S-580-E Double tension film trap door shoe (2)
 - S-581-E Double tension film trap door shoe spring
- E-82 FILM GUIDE HOLDER ASSEMBLY**
- H-118-E Removable door film guide holder *
 - RP-77 Removable door guide holder nut (4)
 - S-1487-E Removable door guide holder screw (4) *

*THESE PARTS ARE NOT SOLD SEPARATELY

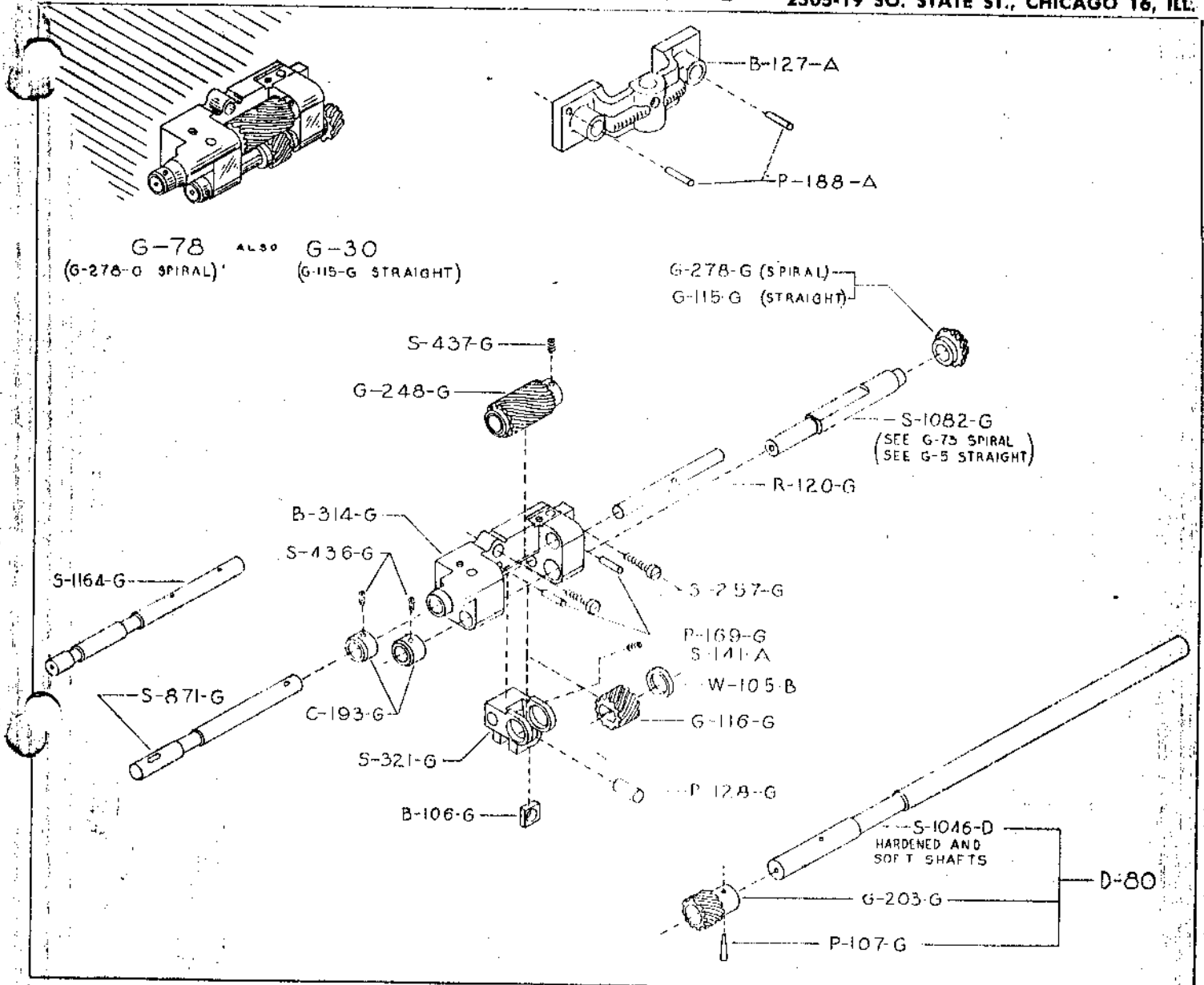

REAR SHUTTER BRACKET AND VERTICAL SHAFT BRACKET

Number	Description
* G-4 AND G-5 (See Page 24)	
G-30 SHUTTER GEAR BRACKET (straight bevel gear type) (Includes G-4 and G-5)	
W-105-G	Shutter driving gear shaft collar
G-116-G	Shutter drive gear
R-120-G	Framing slide guide rod
C-193-G	Shutter shaft collar
G-248-G	Shutter shaft spiral gear
B-314-G	Shutter gear bracket
S-436-G	Shaft collar set screw
S-437-G	Shutter shaft spiral gear set screw
S-871-G	Shutter shaft (rear)
G-73 SPIRAL BEVEL GEAR AND SHAFT ASSEMBLY	
C-193-G	Spiral bevel gear shaft collar
G-278-G	Spiral bevel gear
S-436-G	Shaft collar set screw
S-1082-G	Bevel gear drive shaft
G-78 SHUTTER GEAR BRACKET (spiral bevel gear type) (Includes G-4 and G-73)	

Number	Description
W-105-B	Spiral driving gear shaft washer
G-116-G	Shutter drive gear
R-120-G	Framing slide guide rod
C-193-G	Shutter shaft collar
G-248-G	Shutter shaft spiral gear
B-314-G	Shutter gear bracket
S-436-G	Shutter shaft collar set screw
S-437-G	Shutter shaft spiral gear set screw
S-871-G	Shutter shaft (rear)
D-80 SHUTTER SHAFT AND GEAR	
P-107-G	Shutter gear pin
G-203-G	Shutter shaft gear
S-1046-D	Shutter shaft (specify hard or soft)

PARTS

B-127-A	Vertical shaft bracket
P-169-G	Shutter gear bracket dowel pin
P-188-A	Vertical shaft bracket pin
S-257-G	Shutter gear bracket pin (2)
S-1164-G	Shutter shaft for (rear shutter)

*THESE PARTS ARE NOT SOLD SEPARATELY

PLEASE ORDER BY NUMBER

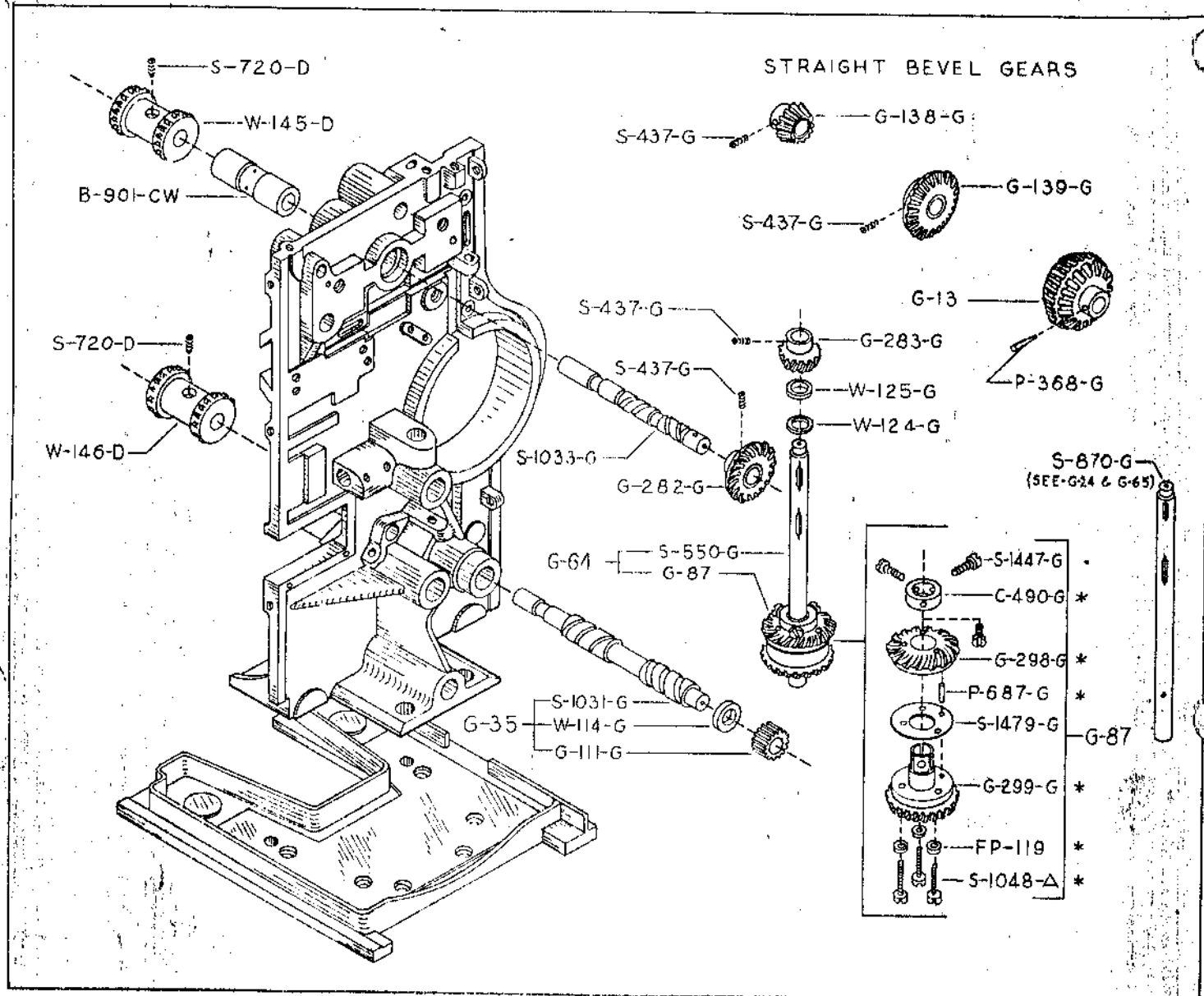

SPROCKET DRIVING GEARS WITH SHAFTS AND SPROCKETS

Number	Description	Number	Description
G-13	STRAIGHT FORMICA DOUBLE BEVEL GEAR AND PIN	G-24	STRAIGHT DOUBLE BEVEL GEAR AND SHAFT ASSEMBLY
P-368-G	Straight bevel gear pin	G-13	Straight double bevel gear
G-15	STRAIGHT FORMICA DOUBLE BEVEL GEAR AND VERTICAL SHAFT ASSEMBLED	P-368-G	Straight double bevel gear taper pin
G-13	Straight formica double bevel gear	S-870-G	Vertical shaft
S-550-G	Vertical shaft	G-35	LOWER SPROCKET SHAFT AND GEAR
		G-111-G	Lower sprocket shaft gear (Formica)
		W-114-G	Lower sprocket shaft washer
		S-1031-G	Lower sprocket shaft
		S-1031-G	Over size .001 .002 .003 .004 .005

PLEASE ORDER BY NUMBER

*THESE PARTS ARE NOT SOLD SEPARATELY

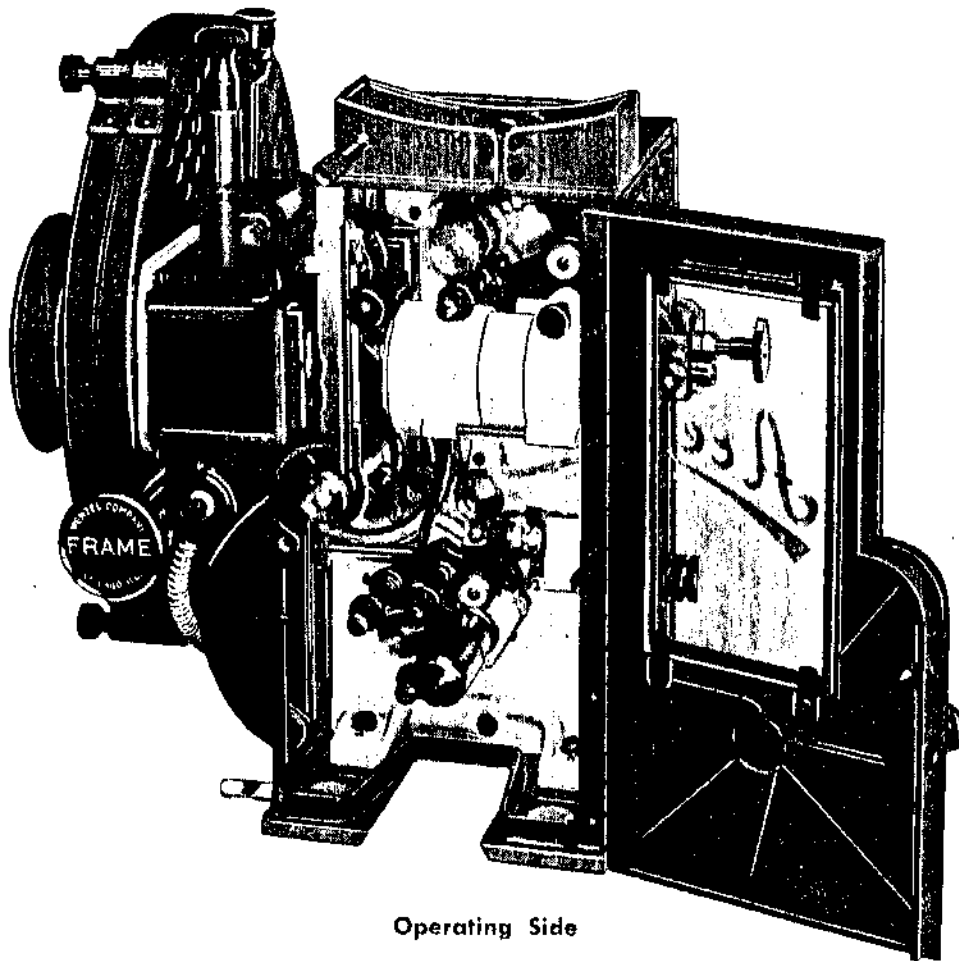

Operating Side

SPROCKET DRIVING GEARS WITH SHAFTS AND SPROCKETS

Number	Description
G-64	SPIRAL DOUBLE BEVEL GEAR AND SHAFT ASSEMBLY
G-87	Spiral bevel gear and clamp
S-550-G	Vertical shaft
G-65	SPIRAL DOUBLE BEVEL GEAR AND SHAFT ASSEMBLY
G-87	Spiral double bevel gear and clamp assembly
S-870-G	Vertical shaft
G-87	SPIRAL DOUBLE BEVEL GEAR AND CLAMP ASSEMBLY
G-298-G	Vertical shaft driving spiral bevel gear *
G-299-G	Vertical shaft driven spiral bevel gear *
FP-119	Double bevel gear fastening screw washer *
C-490-G	Double bevel gear clamp collar *
P-687-G	Double bevel gear locating dowel pin *

Number	Description
S-1048-A	Double bevel gear fastening screw (3) *
S-1447-G	Double bevel gear clamp collar screw
S-1479-G	Double bevel gear shim

PARTS

W-124-G	Vertical shaft washer (lower — .094)
W-125-G	Vertical shaft washer (upper — .0625)
G-138-G	Vertical shaft top straight bevel gear (No. 3)
G-139-G	Upper sprocket shaft straight bevel gear
W-145-D	Upper sprocket, hardened and ground
W-146-D	Lower sprocket, hardened and ground
B-262-G	Vertical shaft replacement bearing
G-282-G	Upper sprocket shaft spiral bevel gear
G-283-G	Vertical shaft top spiral gear
S-437-G	Bevel gear set screw
S-720-D	Upper and lower sprocket set screw
B-901-CW	Upper sprocket shaft bushing, hardened
S-1033-G	Upper sprocket shaft (regular)
S-1033-G	Over size .001 .002 .003 .004 .005

PLEASE ORDER BY NUMBER

*THESE PARTS ARE NOT SOLD SEPARATELY

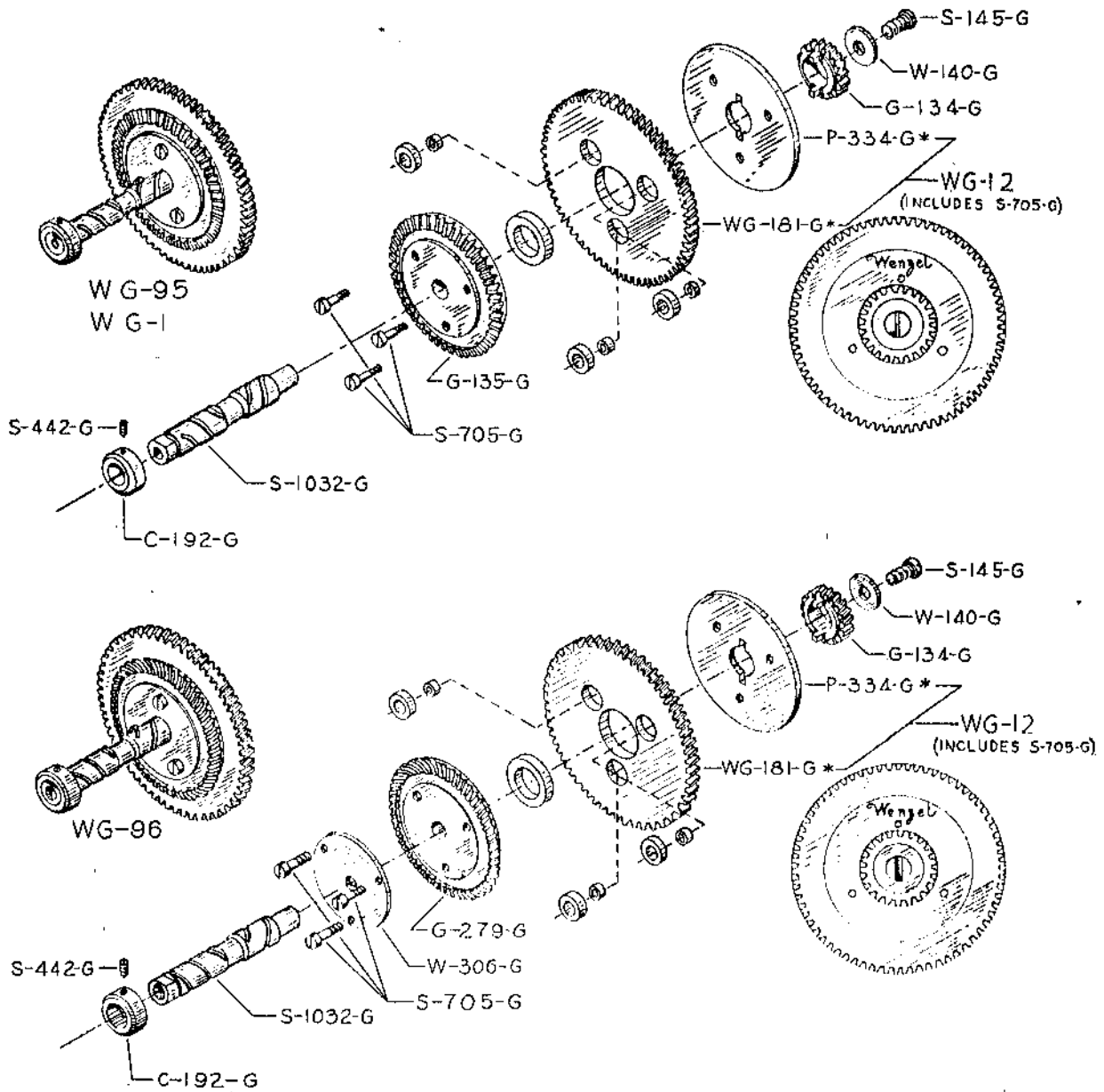

INTERMEDIATE GEARS AND SHAFT (Straight bevel gear shock proof type)

Number	Description
WG-12	SHOCK PROOF INTERMEDIATE GEAR AND PLATE ASSEMBLY
WG-181-G	Shock proof intermediate gear *
P-334-G	Intermediate gear plate *
S-705-G	Intermediate gear screw (3)
WG-95	SHOCK PROOF INTERMEDIATE GEAR AND SHAFT (straight bevel type)
WG-12	Shock proof intermediate gear and plate assembly
G-134-G	Intermediate small steel gear (No. 1)
G-135-G	Intermediate straight bevel gear
W-140-G	Intermediate gear retaining washer
S-145-G	Intermediate gear washer screw
C-192-G	Intermediate shaft gear collar
S-442-G	Intermediate shaft collar set screw

Number	Description
S-1032-G	Intermediate shaft
WG-96	SHOCK PROOF INTERMEDIATE GEAR AND SHAFT (spiral bevel type)
WG-12	Shock proof intermediate gear and plate assembly
G-134-G	Intermediate small steel gear (No.1)
W-140-G	Intermediate gear retaining washer
S-145-G	Intermediate gear washer screw
C-192-G	Intermediate shaft gear collar
G-279-G	Intermediate spiral bevel gear
W-306-G	Intermediate spiral gear spacer
S-442-G	Intermediate shaft collar set screw
S-1032-G	Intermediate shaft
S-1032-G	Over size .001 .002 .003 .004 .005

PLEASE ORDER BY NUMBER

*THESE PARTS ARE NOT SOLD SEPARATELY

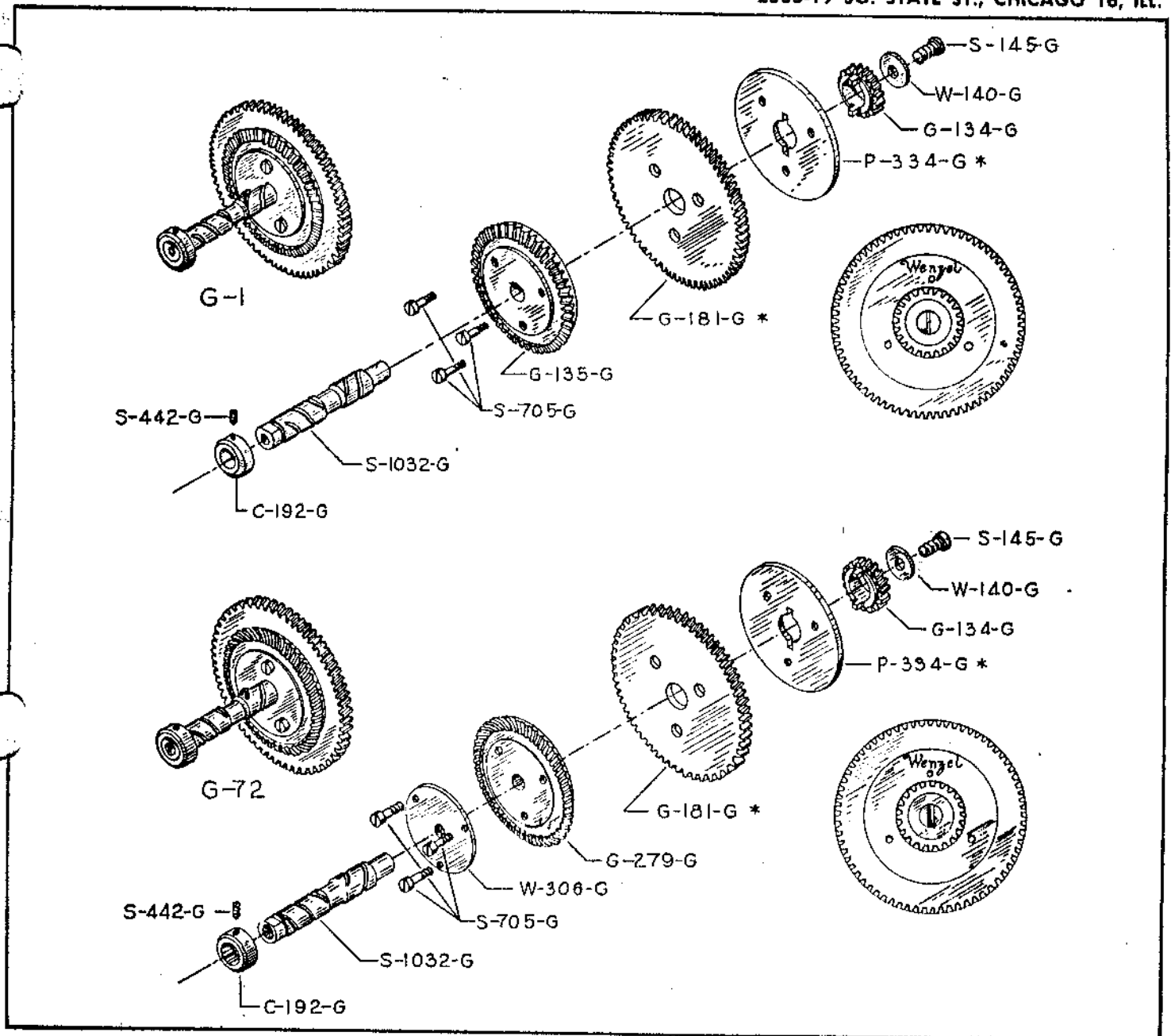

INTERMEDIATE GEAR AND SHAFT (straight bevel type)

Number	Description
G-1	INTERMEDIATE GEAR AND SHAFT
G-12	Formica intermediate gear & plate assy.
G-134-G	Intermediate small steel gear (No. 1)
G-135-G	Intermediate straight bevel gear
W-140-G	Intermediate gear retaining washer
S-145-G	Intermediate gear washer screw
C-192-G	Intermediate shaft gear collar
S-442-G	Intermediate shaft collar set screw
S-1032-G	Intermediate shaft
G-12	FORMICA INTERMEDIATE GEAR & PLATE ASS'Y.
G-181-G	Formica intermediate gear *
P-334-G	Intermediate gear plate *
S-705-G	Intermediate gear screw (3)

Number	Description
G-72	INTERMEDIATE GEAR AND SHAFT (SPIRAL BEVEL)
G-12	Formica intermediate gear & plate assy.
G-134-G	Intermediate small steel gear No. 1
W-140-G	Intermediate gear retaining washer
S-145-G	Intermediate gear washer screw
C-192-G	Intermediate shaft gear collar
G-279-G	Intermediate spiral bevel gear
W-306-G	Intermediate spiral bevel gear spacer plate
S-442-G	Intermediate shaft collar set screw
S-1032-G	Intermediate shaft
S-1032-G	Over size .001 .002 .003 .004 .005

PLEASE ORDER BY NUMBER

*THESE PARTS ARE NOT SOLD SEPARATELY

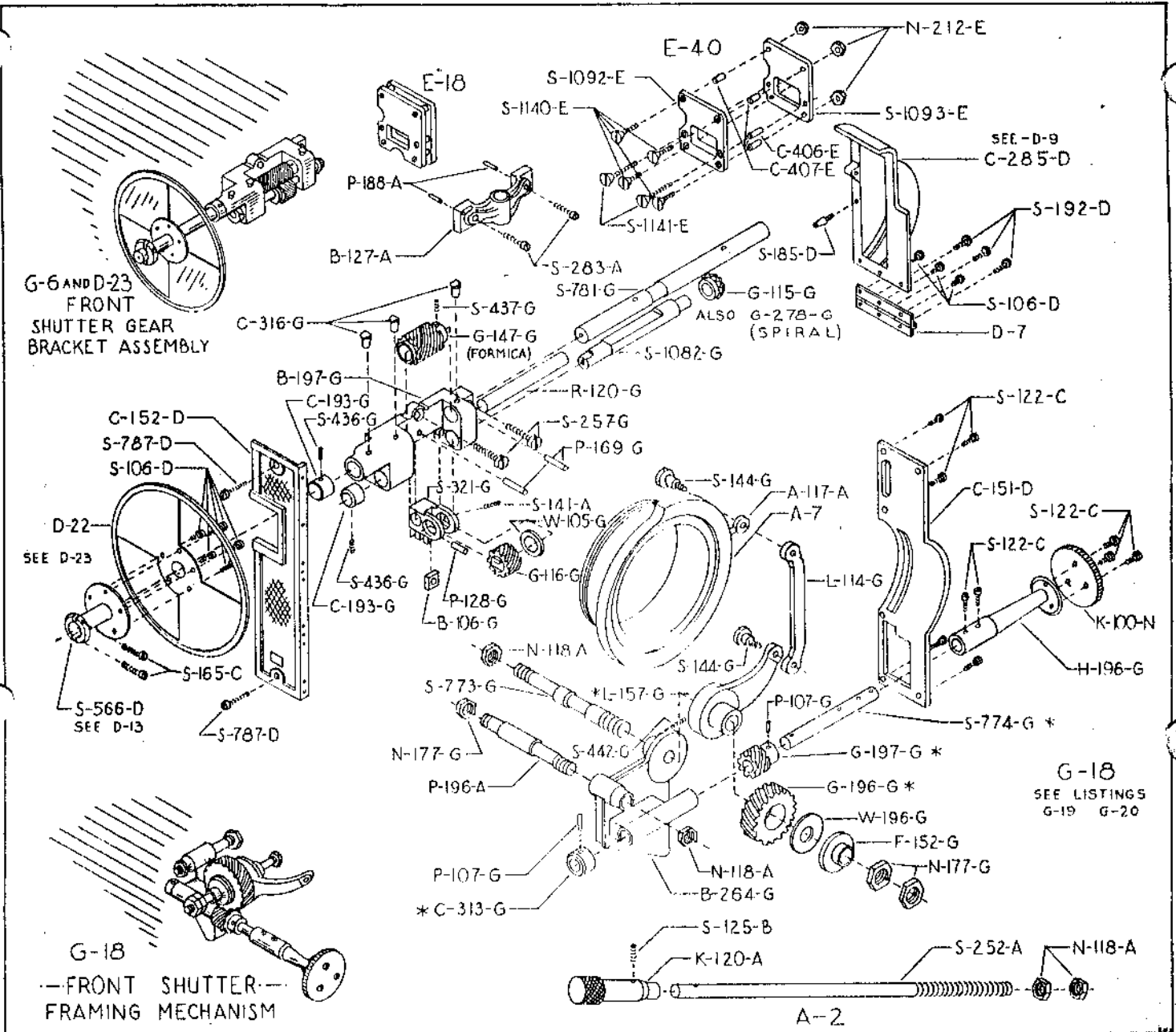

PARTS FOR FRONT SHUTTER MECHANISMS

Number	Description
A-2 SHUTTER ADJUSTING SCREW AND KNOB ASSEMBLY	
K-120-A	Shutter adjusting screw knob
S-125-B	Shutter adjusting screw knob set screw
S-252-A	Shutter adjusting screw
G-4 FRAMING SLIDE AND BLOCK ASSEMBLY	
B-106-G	Framing slide lever block
P-128-G	Framing slide lever pin
S-321-G	Framing slide
G-5 BEVEL GEAR AND SHAFT ASSEMBLY	
G-115-G	Bevel gear
C-193-G	Bevel gear collar
S-436-G	Shaft collar set screw
S-1082-G	Bevel gear drive shaft

Number	Description
G-6 SHUTTER GEAR BRACKET ASSEMBLY	
G-4	Framing slide and block assembly
G-5	Bevel gear and shaft assembly
G-116-G	Shutter driving gear with broached hole
B-197-G	Shutter gear bracket and oil cups
C-316-G	Oil cups (3)
G-147-G	Spiral gear (formica)
R-120-G	Framing slide guide rod
S-141-A	Framing slide set screw
S-437-G	Shutter spiral gear set screw
S-781-G	Front shutter shaft
W-105-B	Spiral drive gear shaft washer

PLEASE ORDER BY NUMBER

*THESE PARTS ARE NOT SOLD SEPARATELY

PARTS FOR FRONT SHUTTER MECHANISMS

Number	Description
A-7	FRAMING CAM, ARM, AND PIN ASSEMBLY
D-7	RIGHT DRUM COVER HINGE ASSEMBLY
D-9	FILMSIDE DRUM COVER ASSEMBLY
S-106-D	Hinge screw (3)
S-185-D	Lockstop screw
C-285-D	Film side drum cover
D-13	SHUTTER SPIDER ASSEMBLY
S-165-C	Shutter spider screw (2)
S-566-D	Shutter spider *
D-22	TWO WING OPAQUE SHUTTER (REGULAR)
D-23	TWO WING SHUTTER AND SPIDER ASSEMBLY
D-13	Shutter spider assembly
D-22	Two wing opaque shutter
S-106-D	Shutter screw (5)
G-18	HEAT SHIELD, OLD STYLE (with cut out for old style right back drum cover latch knob)
N-132-U	Heat shield nut (4)
S-651-E	Film trap back heat shield
S-652-E	Film trap front heat shield
S-653-E	Heat shield screws and spacers (6)
G-18	FRAMING MECHANISM (new style)
G-19	Framing mechanism driving shaft and collar
G-20	Framing lever and gear
K-100-N	Framing mechanism fibre knob
S-122-C	Framing mechanism screw (5)
F-152-G	Framing lever gear friction flange
H-196-G	Framing mechanism handle
W-196-G	Framing lever gear friction washer
N-177-G	Framing lever gear friction adjusting nut (2)
B-264-G	Framing mechanism support bracket
S-442-G	Framing mechanism set screw
S-773-G	Framing lever pivot stud

Number	Description
G-19	FRAMING MECHANISM DRIVING SHAFT GEAR AND COLLAR
P-107-G	Taper pin (2)
G-197-G	Framing mechanism driving shaft gear *
C-313-G	Framing driving shaft collar *
S-774-G	Framing mechanism driving shaft *
G-20	FRAMING LEVER AND GEAR
L-157-G	Framing lever *
G-196-G	Framing lever gear *
E-40	FILM TRAP ASBESTOS HEAT SHIELD
N-212-E	Heat shield screw nut (4)
C-406-E	Heat shield fastening screw spacer collar (2)
C-407-E	Heat shield spacer collar (4)
S-1092-E	Rear heat shield
S-1093-E	Front heat shield
S-1140-E	Heat shield spacer screw (4)
S-1141-E	Heat shield fastening screw (2)
R-15	DOUBLE APERTURE LIGHT SHIELD
G-180-R	Double aperture light shield glass (2)
N-135-W	Double aperture light shield nut (2)
S-427-U	Double aperture light shield screw (2)
S-700-R	Double aperture light shield only
S-755-R	Double aperture light shield spring
G-136-R	APERTURE LIGHT SHIELD GLASS FOR R-8

PARTS

W-106-G	Framing handle friction washer
L-114-G	Picture framing connecting link
N-118-A	Picture framing handle pivot nut
S-122-C	Cover fastening screw
N-123-A	Adjusting screw lock nut
B-127-A	Vertical shaft bracket
S-144-G	Picture framing link screw
S-142-G	Picture framing lever pivot screw
C-151-D	Gear side back cover (for front shutter only)
C-152-D	Gear side front cover
P-169-G	Shutter gear bracket dowel pin
P-188-A	Vertical shaft bracket dowel pin
S-192-D	Drum cover hinge fastening screw (3)
C-193-G	Shutter shaft collar
P-196-A	Picture framing handle pivot
S-222-G	Picture framing link screw
S-223-G	Picture framing connecting link screw
S-257-G	Shutter gear bracket screw
S-283-A	Vertical shaft bracket screw
S-436-G	Shaft collar set screw
S-787-D	Gear side front cover screw

PLEASE ORDER BY NUMBER

25

*THESE PARTS ARE NOT SOLD SEPARATELY

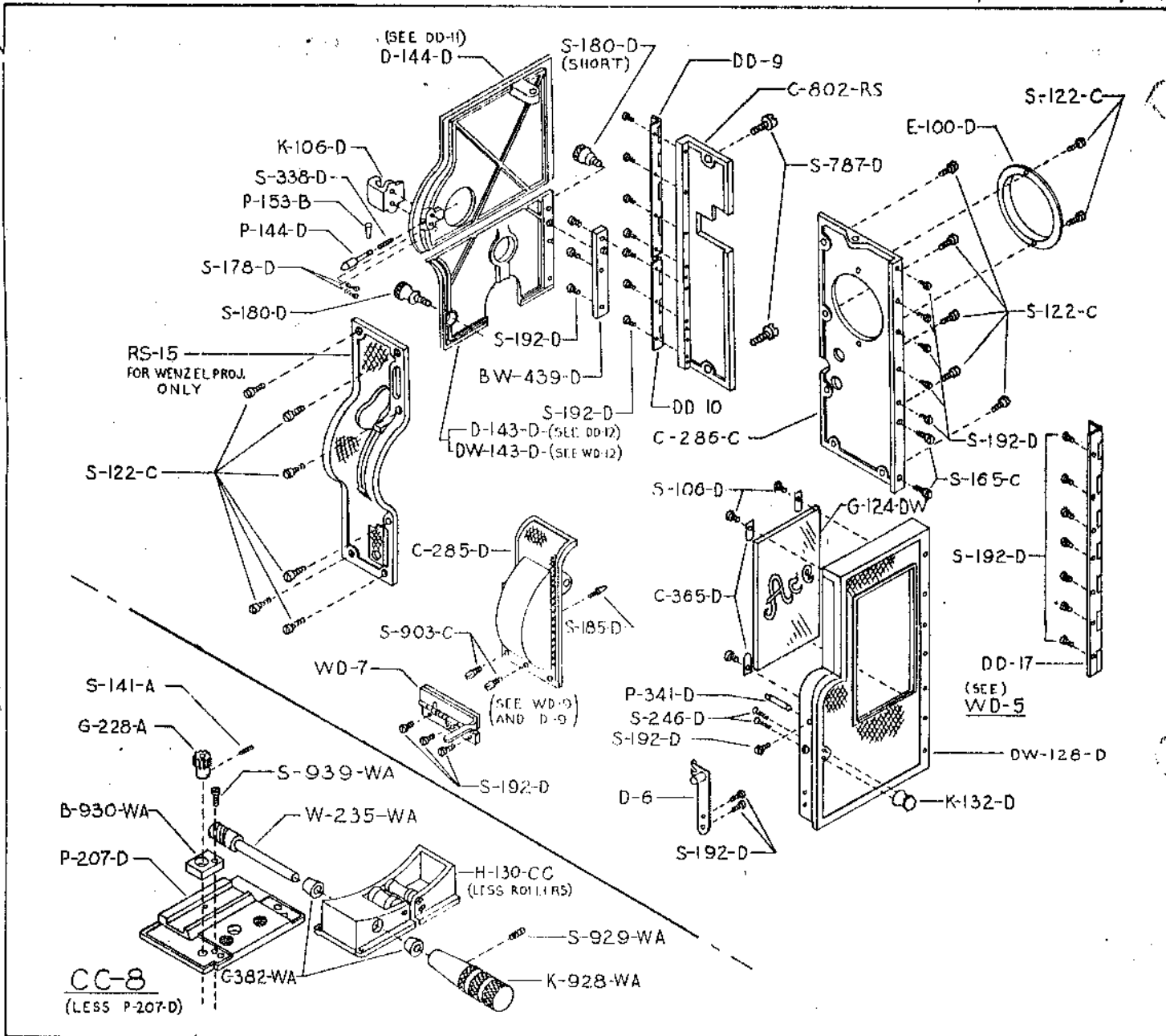

PROJECTOR COVERS AND UPPER MAGAZINE ROLLER HOLDER FOCUSING DEVICE

Number	Description
WD-5	FILM SIDE ONE PIECE DOOR ASSEMBLY
D-6	Film side door lock spring and button
DD-17	Film side door hinge assembly
DW-128-D	Film side one piece door
K-132-D	Film side door knob
S-192-D	Cover linkage locking pin fastening screw and D-6 fastening screw (2)
S-246-D	Film side door hinge screw (7)
P-341-D	Cover linkage locking pin
WD-7	FILM SIDE DRUM COVER FINGER ACTION RELEASING HINGE
S-192-D	Hinge fastening screw (3)

Number	Description
CC-8	UPPER MAGAZINE ROLLER HOLDER AND FOCUSING DEVICE (Wenzel "Ace" projector only)
H-130-CC	Upper magazine roller holder
S-141-A	Focusing gear set screw
G-228-A	Focusing gear
W-235-WA	Worm shaft for focusing device
C-382-WA	Adjusting knob collars (2)
K-928-WA	Knob for focusing
S-929-WA	Focusing knob set screw
S-930-WA	Focusing gear holding bracket
S-939-WA	Focusing gear holding bracket fastening screw

PLEASE ORDER BY NUMBER

*THESE PARTS ARE NOT SOLD SEPARATELY

PROJECTOR COVERS AND UPPER MAGAZINE ROLLER HOLDER FOCUSING DEVICE

Number	Description
DD-9	GEAR SIDE UPPER DOOR HINGE ASSEMBLY
WD-9	FILM SIDE DRUM COVER, SLIP IN TYPE ASSEMBLY
WD-7	Film side drum cover finger action cover releasing hinge
S-185-D	Film side drum cover spring lock screw
C-285-D	Film side drum cover
S-903-C	Film side drum cover locating screw (2)
DD-10	GEAR SIDE LOWER DOOR HINGE ASSEMBLY
DD-11	GEAR SIDE UPPER DOOR AND KNOB ASSEMBLY
DD-9	Gear side upper door hinge assembly
K-106-D	Gear side upper door knob
D-144-D	Gear side upper door
P-144-D	Gear side upper door lock pin
P-153-B	Gear side upper door lock pin retainer
S-178-D	Gear side upper door knob fastening screw (2)
S-192-D	Gear side upper door hinge screw (4)
S-338-D	Gear side upper door lock pin spring
DD-12	GEAR SIDE LOWER DOOR ASSEMBLY
DD-10	Gear side lower door hinge assembly
D-143-D	Gear side lower door
S-192-D	Gear side lower door hinge screw (3)

Number	Description
WD-12	GEAR SIDE LOWER DOOR COMPLETE WITH BRACKET AND HOLDING SCREW
DW-143-D	Gear side lower door for bracket
S-180-D	(short) Gear side lower door holding screw
S-192-D	Gear side lower door bracket fastening screw (3)
BW-439-D	Gear side lower door holding bracket
RS-15	GEAR SIDE BACK COVER (Wenzel projector only)
DD-17	FILM SIDE DOOR HINGE

PARTS

P-207-D	Top plate
E-100-D	Escutcheon
S-106-D	Film side door glass clamp fastening screw (4)
S-122-C	Cover screw
G-124-DW	Film side door glass for "Ace" projector
S-155-C	Film side door hinge fastening screw (2)
S-180-D	Gear side lower door lock screw
S-192-D	Hinge screws
C-286-C	Film side front cover
C-365-D	Film side door glass clamp (4)
S-787-D	Gear side front cover screw (2)
C-802-RS	Gear side front cover (Wenzel projector only)

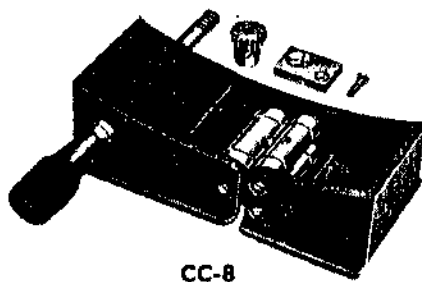

CC-8

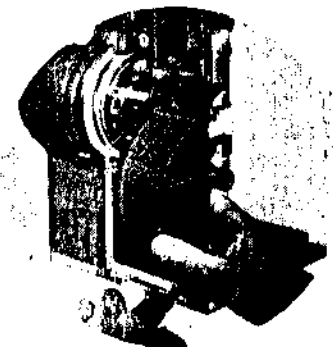

WD-9

PLEASE ORDER BY NUMBER

*THESE PARTS ARE NOT SOLD SEPARATELY

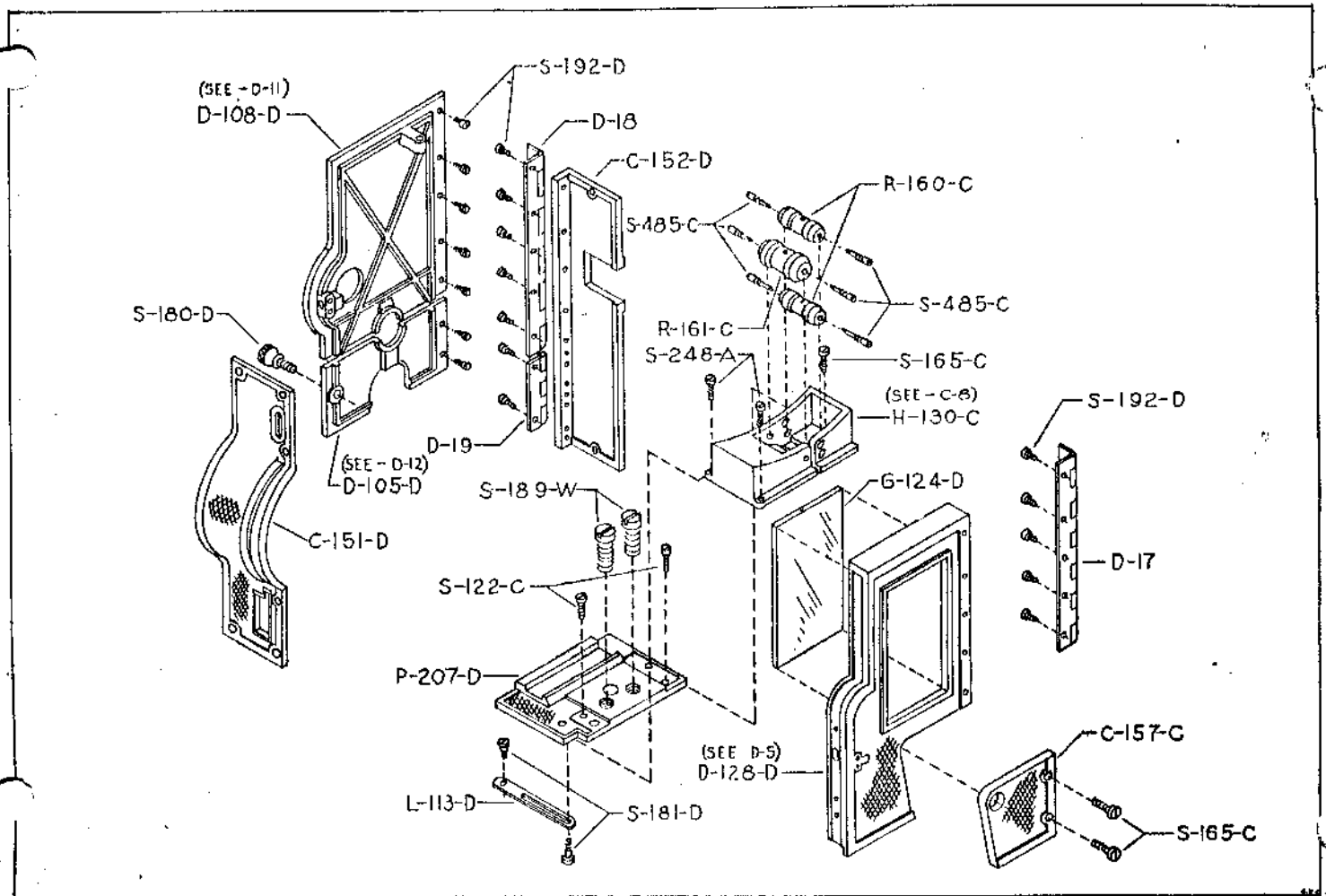

PROJECTOR COVERS (OLD STYLE)

Number	Description
D-4	FILM SIDE DOOR AND HINGE
D-17	Film side door hinge
D-128-D	Film side door
S-192-D	Film side door hinge screw (5)
D-5	FILM SIDE DOOR AND KNOB
D-4	Film side door and hinge
K-132-D	Door knob
S-246-D	Door knob screw (2)
D-11	GEAR SIDE UPPER DOOR AND KNOB ASSEMBLY
D-18	Gear side upper door hinge
K-106-D	Gear side upper door knob
D-108-D	Gear side upper door
S-178-D	Gear side upper door knob screw (2)
S-192-D	Gear side upper door hinge screw (5)
D-12	GEAR SIDE LOWER DOOR AND HINGE ASSEMBLY
D-19	Gear side lower door hinge
D-105-D	Gear side lower door
S-192-D	Gear side lower door hinge screw (2)
C-8	UPPER MAGAZINE ROLLER HOLDER ASSEMBLY
H-130-C	Upper magazine roller holder
R-160-C	Magazine roller small (2)
R-161-C	Magazine roller large
S-485-C	Magazine roller pivot screw (6)

Number	Description
D-17	FILM SIDE DOOR HINGE
D-18	GEAR SIDE UPPER DOOR HINGE
D-19	GEAR SIDE LOWER DOOR HINGE

PARTS

C-151-D	Gear side back cover
C-152-D	Gear side front cover
L-113-D	Gear side upper door stop link
S-122-C	Top plate cover screw (2)
G-124-D	Film side door glass
C-157-C	Film side lower cover
S-165-C	Front fastening screw for H-130-C and fastening screw for C-157-C
S-180-D	Gear side lower door lock screw
S-181-D	Gear side upper door stop link screw
S-189-W	Upper magazine bracket fastening screw (2)
P-207-D	Top plate
S-248-A	Upper magazine roller holder fastening screw (rear) (2)

PLEASE ORDER BY NUMBER

*THESE PARTS ARE NOT SOLD SEPARATELY

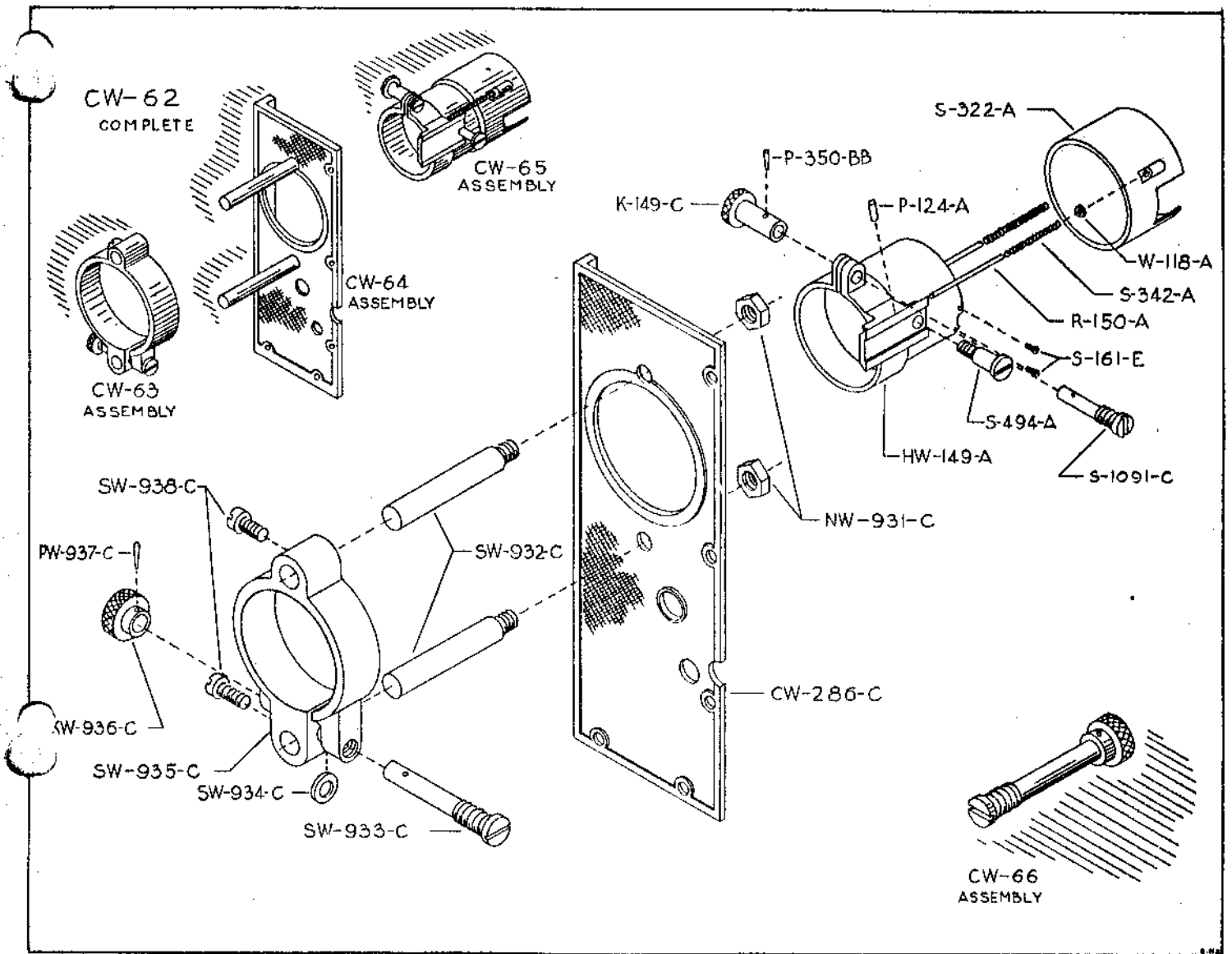

LENS HOLDER AND SUPPORT BRACKET ASSEMBLY FOR 2-3/16" LENS

Number	Description	Number	Description
CW-62	LENS HOLDER & SUPPORT BRACKET COMPLETE	HW-149-A	Projecting lens holder for 2-3/16" diameter lens
	CW SUB-ASSEMBLES	K-149-C	Clamp knob
CW-63	LENS SUPPORT BRACKET ASSEMBLY	R-150-A	Projecting lens holder slide guide rod (2)
	SW-933-C Clamp knob screw	S-322-A	Projecting lens holder slide
	SW-934-C Clamp knob screw washer	S-161-E	Projecting lens holder slide stop screw (2)
	SW-935-C Lens support bracket	S-342-A	Projecting lens holder slide guide rod spring (2)
	KW-936-C Clamp knob	P-350-BB	Clamp knob pin
	PW-937-C Clamp knob taper pin	S-494-A	Focusing rack retaining screw
	SW-938-C Support bracket stop screw (2)	S-1091-C	Clamp knob screw
CW-64	LENS SUPPORT BRACKET COVER ASSEMBLY	CW-66	CLAMP KNOB AND SCREW FOR SUPPORT BRACKET
	CW-286-C Lens support bracket cover		SW-933-C Clamp knob screw
	NW-931-C Support bracket stud nut		KW-936-C Clamp knob
	SW-932-C Support bracket studs (2)		PW-937-C Clamp knob taper pin
CW-65	PROJECTING LENS HOLDER AND SLIDE FOR 2-3/16" LENS (includes C-38)		
	W-118-A Projecting lens holder slide washer (2)		
	P-124-A Focusing gib pin		

PLEASE ORDER BY NUMBER

*THESE PARTS ARE NOT SOLD SEPARATELY

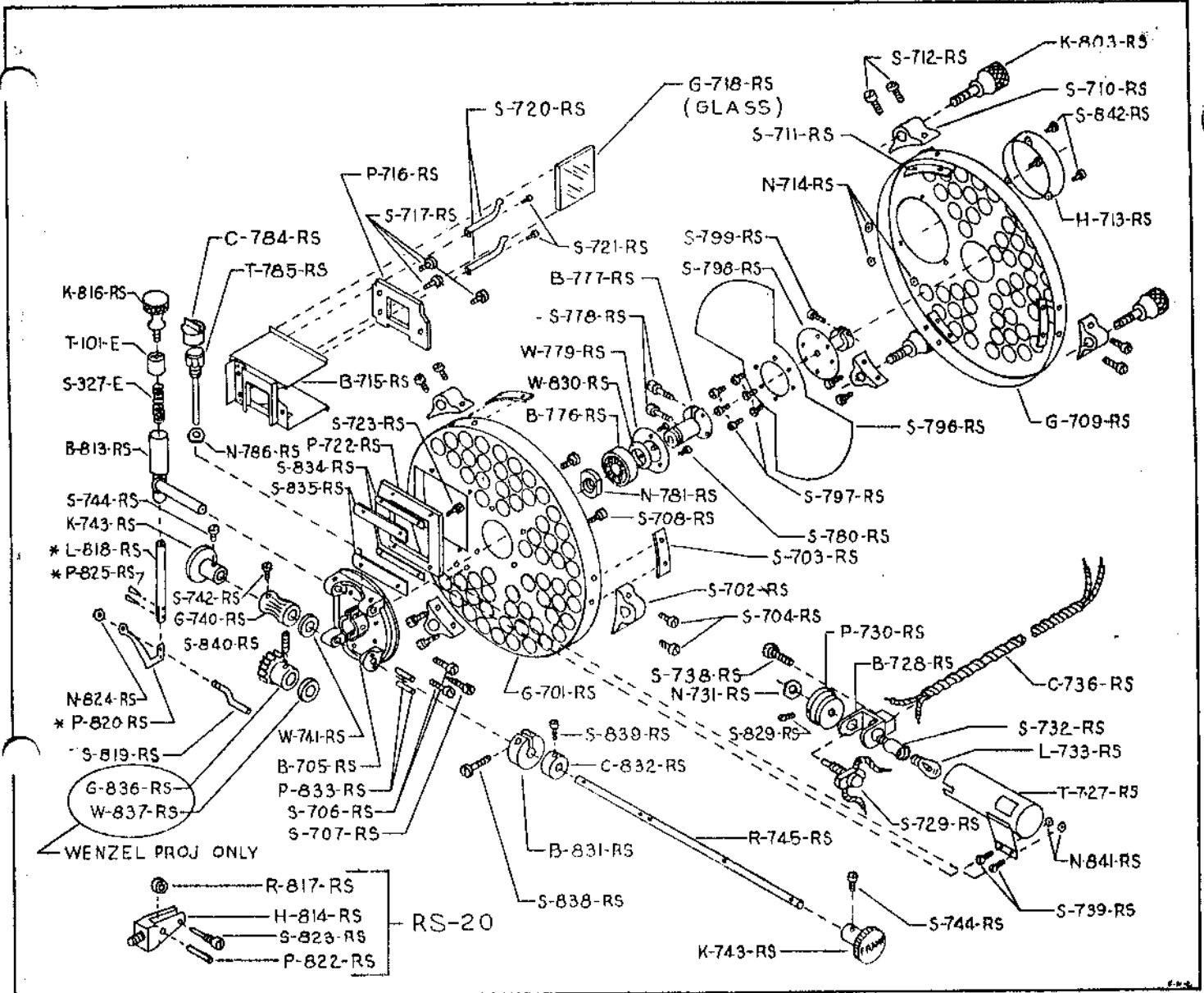

WENZEL "ACE" REAR SHUTTER

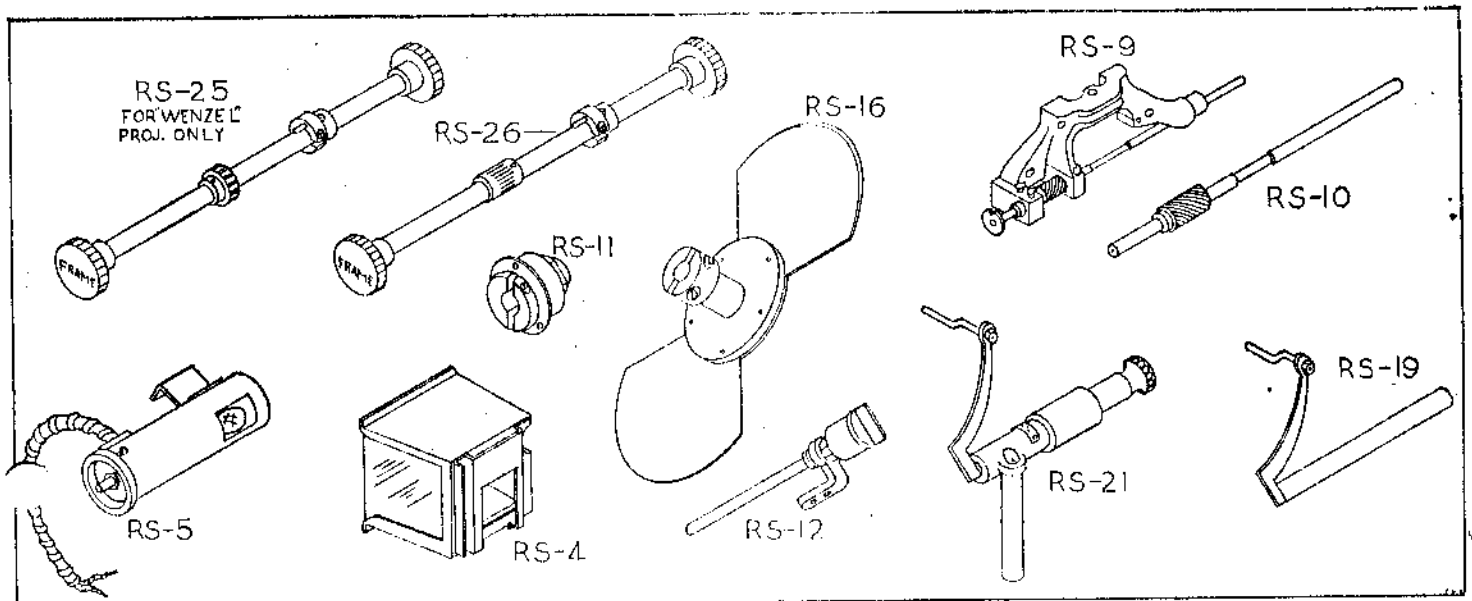

PLEASE ORDER BY NUMBER

*THESE PARTS ARE NOT SOLD SEPARATELY

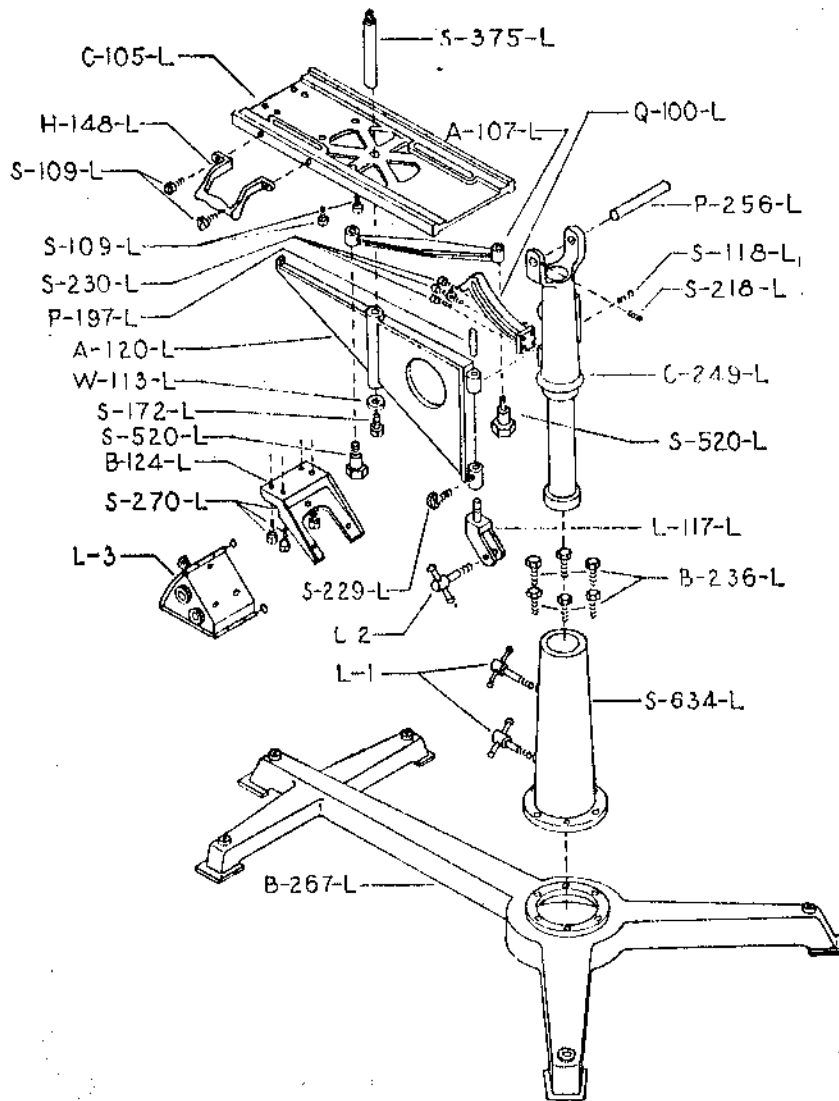

---FIVE POINT---
PEDESTAL ASSEMBLY

FIVE POINT PEDESTAL

Number	Description	Number	Description
"L" PEDESTAL COMPLETE WITH B-267-L FIVE POINT BASE			
L-1	PEDESTAL STAND HANDLE ASSEMBLY	A-107-L	Auxiliary arm
L-2	QUADRANT LOCK CLAMP HANDLE ASSEMBLY	S-109-L	Lamphouse carriage handle retaining screw
L-3	SWITCH BOX AND COVER	W-113-L	Lamphouse carriage washer
L-4	SIXTY AMPERE SWITCH BOX, SWITCH AND BRACKET ASSEMBLIES (Includes L-3)	L-117-L	Quadrant lock
B-124-L	Switch box bracket	S-118-L	Pedestal pivot set screw
N-132-U	Retaining nut (3)	A-120-L	Slide over arm
N-162-L	3/4" chase lock nut (4)	H-148-L	Lamphouse carriage handle
N-163-L	3/4" chase nipple (4)	S-172-L	Lamphouse carriage pivot
B-189-L	Switch box and cover	P-197-L	Slide over arm pivot
W-197-L	Retaining screw washer (3)	S-218-L	Pedestal arm pivot screw
B-240-L	3/4" chase bushing (4)	S-229-L	Quadrant lock retaining thumb screw
S-387-L	Sixty ampere switch	S-230-L	Quadrant stand screw
S-388-L	One hundred ampere switch	B-236-L	Pedestal base bolt (6)
S-408-Q	Retaining screw (3)	C-249-L	Pedestal column
PARTS			
Q-100-L	Quadrant	P-256-L	Pedestal arm pivot
C-105-L	Lamphouse carriage	B-267-L	Pedestal base (five point)
		S-270-L	Switch box screw (4)
		S-375-L	Lamphouse carriage pivot screw
		S-520-L	Auxiliary arm pivot screw
		S-634-L	Pedestal stand

PLEASE ORDER BY NUMBER

*THESE PARTS ARE NOT SOLD SEPARATELY

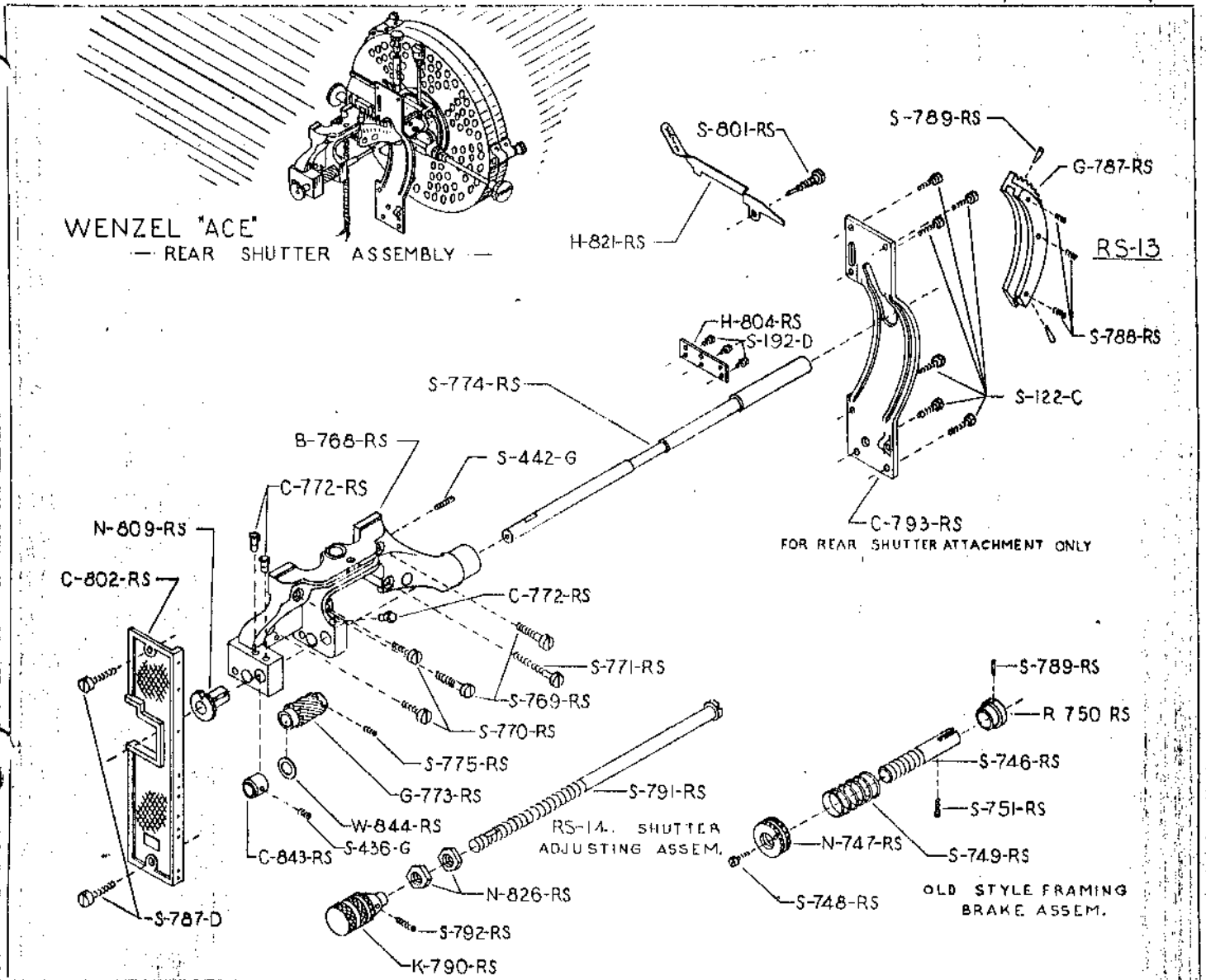

WENZEL BRACKET FOR REAR SHUTTER ATTACHMENTS

- | Number | Description |
|--------------|---|
| RS-9 | REAR SHUTTER BRACKET AND OIL CUPS |
| RS-10 | Shutter shaft assembly |
| B-768-RS | Rear shutter bracket |
| S-769-RS | Rear shutter bracket screw large (2) |
| S-770-RS | Rear shutter bracket screw small (2) |
| S-771-RS | Rear shutter bracket screw long |
| C-772-RS | Rear shutter bracket oil cups (3) |
| RS-10 | SHUTTER SHAFT ASSEMBLY |
| G-773-RS | Shutter gear (formica) |
| S-774-RS | Rear shutter shaft |
| S-775-RS | Rear shutter shaft gear set screw |
| N-809-RS | Rear shutter shaft framing nut |
| C-843-RS | Shutter shaft collar (oilite) |
| S-436-G | Shutter shaft collar set screw |
| W-844-RS | Shutter shaft gear spacer washer (oilite) |
| RS-13 | FRAMING CAM GEAR |
| G-787-RS | Framing cam gear (for rear shutter attachment only) |
| G-788-RS | Framing cam gear set screw (3) |
| S-789-RS | Rear shutter attachment stop stud (2) |

- | Number | Description |
|---|-------------------------------------|
| RS-14 | SHUTTER ADJUSTING ASSEMBLY |
| R-790-RS | Shutter adjusting screw knob |
| S-791-RS | Shutter adjusting screw |
| S-792-RS | Shutter adjusting knob set screw |
| N-826-RS | Nut for shutter adjusting screw |
| OLD STYLE FRAMING BRAKE ASSEMBLY | |
| S-746-RS | Framing rod friction device sleeve |
| N-747-RS | Friction device lock nut |
| S-748-RS | Lock nut set screw |
| S-749-RS | Friction device spring |
| R-750-RS | Framing gear friction sleeve ring |
| S-751-RS | Framing rod device sleeve set screw |

- PARTS**
- | | |
|----------|--|
| S-122-C | Gear side back cover fastening screw (6) |
| S-192-D | Fastening screw for H-804-RS hinge plate |
| S-787-D | Gear side front cover screw (2) |
| C-793-RS | Gear side back cover |
| S-801-RS | Fire shutter lift lever handle pivot screw |
| C-802-RS | Gear side front cover (special for rear shutter) |
| H-804-RS | Drum cover hinge (special for rear shutter) |
| H-821-RS | Handle to lift fire shutter |

PLEASE ORDER BY NUMBER

*THESE PARTS ARE NOT SOLD SEPARATELY