

# Film-Tech

The information contained in this Adobe Acrobat pdf file is provided at your own risk and good judgment.

These manuals are designed to facilitate the exchange of information related to cinema projection and film handling, with no warranties nor obligations from the authors, for qualified field service engineers.

If you are not a qualified technician, please make no adjustments to anything you may read about in these Adobe manual downloads.

[www.film-tech.com](http://www.film-tech.com)

# **SIMPLEX<sup>®</sup>**

## **X-L**

**Projector Mechanism  
Parts Catalog**

**GPL Division - GENERAL PRECISION, Inc.**

November 1, 1960

514E-70

1000

# Safeguard your most Valuable Assets

- GOOD PROJECTION
- PLEASED PATRONS

WHY BE SATISFIED WITH ANYTHING BUT THE BEST! GENUINE *Simplex* PARTS, MADE ONLY BY THE MANUFACTURERS OF FAMOUS *Simplex* PROJECTORS, SAFEGUARD THE PRECISION OF YOUR *Simplex* EQUIPMENT, ASSURING EXTRAORDINARY PERFORMANCE AND RUGGED DEPENDABILITY.

BETTER PROJECTION PAYS

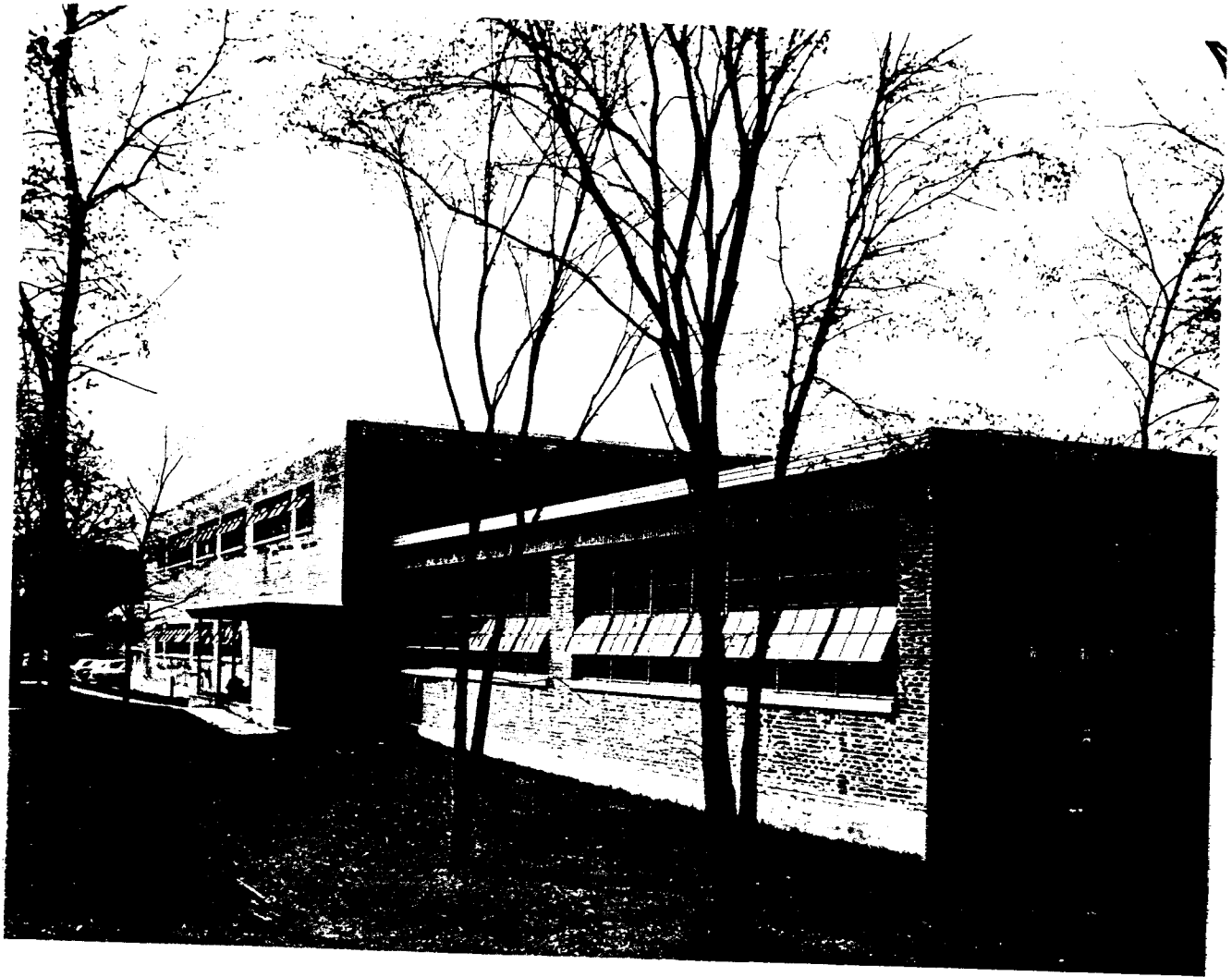

Simplex X-L projectors, formerly manufactured in the Bloomfield, N. J. plant of the International Projector Corporation, will now be produced by the GPL Division - General Precision, Inc., in its modern factory in Pleasantville, N. Y.

GPL Division - General Precision, Inc., a subsidiary of the General Precision Equipment Corporation, which has been associated with the International Projector Corporation for over thirty-five years, has excellent production and engineering facilities. GPL Division, therefore, is capable of maintaining international leadership in the field of motion picture projectors, and providing theatre owners with the finest equipment at the lowest cost.

The competence of our distributors, The National Theatre Supply Company, to advise in emergencies, to install new Simplex equipment, and to deliver genuine Simplex parts, is known to exhibitors throughout the world.

"BETTER PROJECTION PAYS"

# X-L PROJECTOR PARTS CATALOGUE INDEX

## SECTION I

	Page
Film Compartment Door Assembly	1-0
Curved Film Trap Assembly, G-2613	1-2
Aperture Plates	1-2
Curved Film Trap Gate Assembly, G-4318	1-4
Water Cooled Heat Shield Assembly, G-4310	1-5
Film Trap and Gate Mounting and Operating Assembly, G-1905	1-6
Fire Shutter and Associated Parts	1-8
Framing and Idler Gear Assemblies	1-10
Gear Compartment Cover Assembly	1-11
Heat Shield, Dowser and Associated Parts	1-12
Horizontal Main Drive Assembly	1-14
Intermittent Assembly (Regular) G-4312	1-15
Intermittent Assembly (Hi-Speed) G-4126	1-16
Lower Feed Sprocket Assembly, G-1809	1-17
Support for 4" Anamorphic Lenses	1-18
Main Frame, Lens Holder and Screen Scope	1-18
Main Frame, Framing Cam and Oil Gauge	1-20
Oil Pump Assembly, G-1822	1-22
Shutter and Framing Assembly, G-1815	1-24
Spot Sight Box and Lower Rear Cover	1-26
Vertical Shaft and Governor Assembly, G-1801	1-28

## SECTION II

Drive Kit for Simplex Sound Mechanisms, G-2086	2-0
Drive Kit for Century and Westrex R-2, R-6, and Westrex Master Soundhead, G-2195	2-0
Drive Kit for Motiograph SH-7500 and W.E. TA-7500 Soundhead, G-2069	2-1
Drive Kit for RCA MI-1040 to MI-1077 and MI-9030 to MI-9070 Soundhead, G-2068	2-2
Drive Kit for W.E. TA-7400 Reproducer Set, G-2129	2-2
Drive Kit for RCA PS-24 and MI-1023 to MI-1032 Soundhead, G-2130	2-2
Drive Kit for W.E. 206-208 Reproducer Set, G-2149	2-3
Drive Kit for W.E. Universal Base, G-2180	2-4
Lens Adapter Kit for 2 25/32" Diameter Lens, G-2156	2-5
Lens Adapter Kit for 4" Diameter Lens, F:2.0, G-2157	2-5
Lens Adapter Kit for 4" Diameter Lens, F:1.8, G-2423	2-5
Lens Adapter Kit for 2 1/32" Diameter Lens, G-2158	2-5
Lens Adapter Kit for 2.118" Diameter Lens, G-2159	2-5
Lens Adapter Kit for 2 1/8" Diameter Lens, G-2160	2-5
Projector Changeover for 115 Volts AC, G-2090	2-6
Projector Changeover for 115 Volts DC, G-2091	2-6

## SECTION III

X-L Upper Magazine and Roller Holder Assembly	3-0
X-L Lower Magazine and Roller Holder Assembly	3-2

## SECTION IV

Numerical List of Parts	4-0
-------------------------	-----

# SECTION I

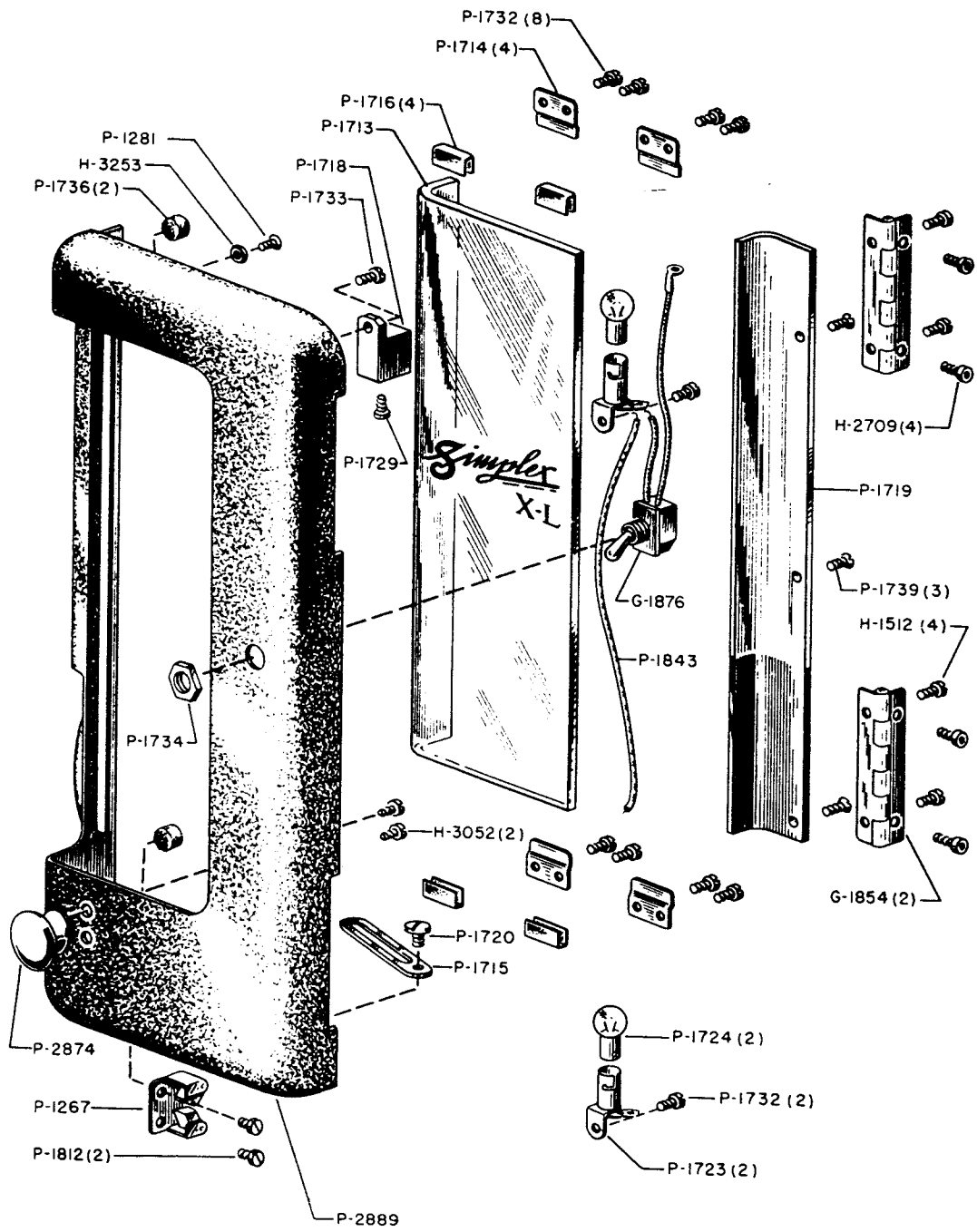

FILM COMPARTMENT DOOR

FILM COMPARTMENT DOOR PARTS

G-1854 Hinge and Pin (2)  
 G-1876 Threading Lamp Switch (SPDT) and Connecting Wires  
 H-1512 Hinge to Door Fastening Screw (4)  
 H-2709 Hinge to Main Frame Fastening Screw (4)  
 H-3052 Knob Fastening Screw (2)  
 H-3253 Framing Lamp Switch Contact Screw Lock Nut  
 P-1267 Door Catch  
 P-1281 Framing Lamp Switch Contact Screw  
 P-1713 Window Glass  
 P-1714 Glass Retaining Clip (4)  
 P-1715 Door Stay  
 P-1716 Window Glass Rubber Mounting (4)  
 P-1718 Terminal Block  
 P-1719 Threading Lamp Cover  
 P-1720 Door Stay Fastening Screw  
 P-1723 Threading Lamp Socket (2)  
 P-1724 Threading Lamp, 6-8V (2)  
 P-1729 Threading Lamp Wires Fastening Screw  
 P-1732 Glass Retaining Clip-Socket Fastening Screw (10)  
 P-1733 Terminal Block-Fastening Screw  
 P-1734 Switch Fastening Nut  
 P-1736 Door Bumper (2)  
 P-1739 Threading Lamp Cover Fastening Screw (3)  
 P-1812 Door Catch Fastening Screw (2)  
 P-1843 Socket Connecting Wire  
 P-2874 Knob  
 P-2889 Film Compartment Door

Allen Wrench No.

Required for

P-2711

H-2709



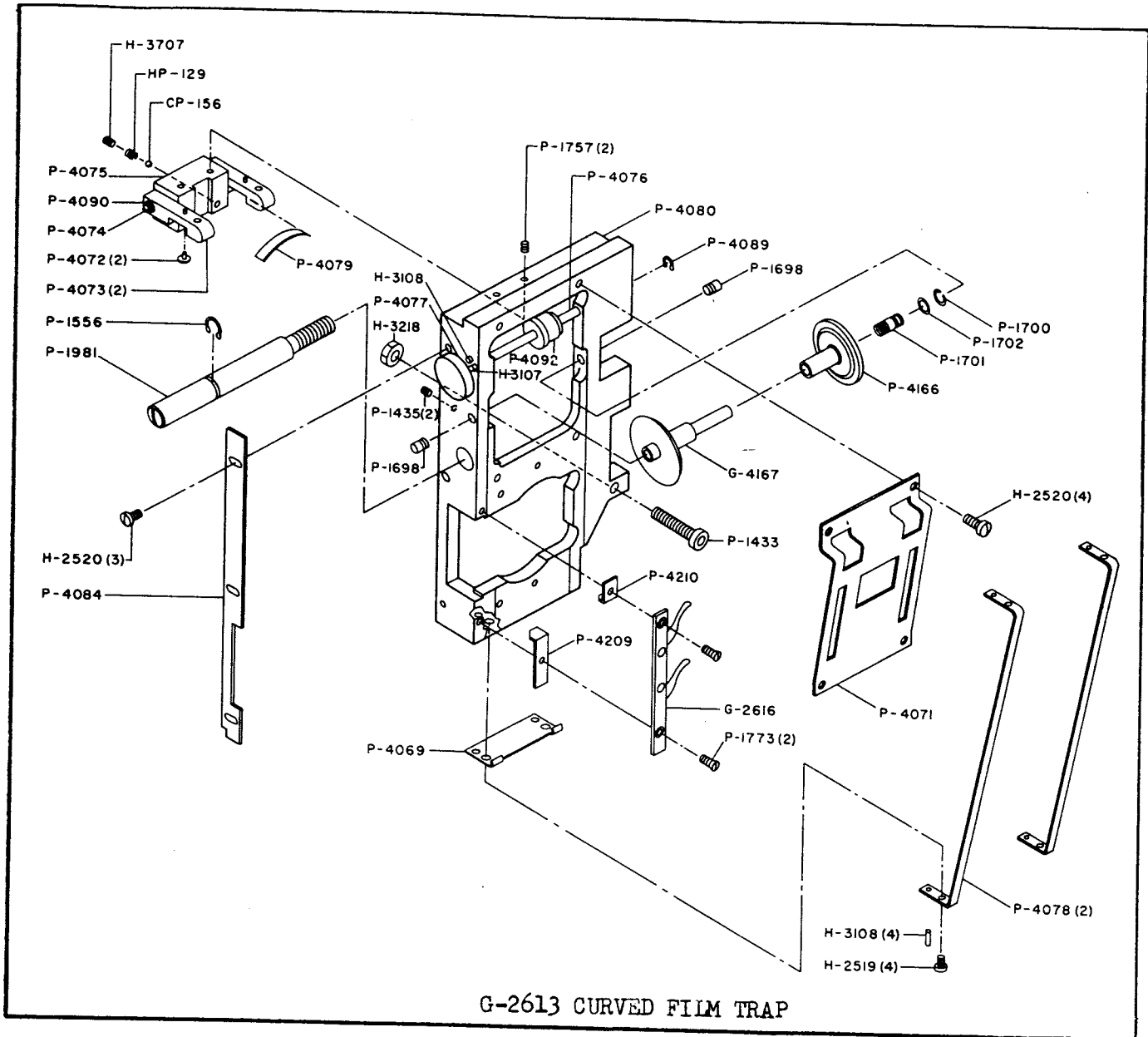

G-2613 CURVED FILM TRAP

APERTURE PLATES\*\*

Part No.	Aperture Size	Screen Ratio	* Filing Required	Type Lens	Sound Track	Type Screen
G-1852	.600 x .825 Sq. Corners	1.37:1	None	Regular	Standard Optical	Flat
G-2109	.600 x .825 Rd. Corners	1.37:1	None	Regular	Standard Optical	Flat
G-2110	.600 x .800 Sq. Corners	1.37:1	Width	Regular	Standard Optical	Flat
G-2111	9/16" x 3/4" Rd. Corners	Sub-Standard	Width & Height	Regular	Standard Optical	Flat
G-2302	.412 x .800 Sq. Corners	2:1	Width	Short Focal	Standard Optical	Flat
G-2303	.446 x .800 Sq. Corners	1.85:1	Width	Short Focal	Standard Optical	Flat
G-2304	.471 x .800 Sq. Corners	1.75:1	Width	Short Focal	Standard Optical	Flat
G-2305	.412 x .825 Sq. Corners	2:1	None	Short Focal	Standard Optical	Flat
G-2306	.446 x .825 Sq. Corners	1.85:1	None	Short Focal	Standard Optical	Flat
G-2307	.471 x .825 Sq. Corners	1.75:1	None	Short Focal	Standard Optical	Flat
G-2308	.497 x .825 Sq. Corners	1.66:1	None	Short Focal	Standard Optical	Flat
G-2309	.497 x .800 Sq. Corners	1.66:1	Width	Short Focal	Standard Optical	Flat
G-2402	.650 x .650 Sq. Corners	2:1	Width & Height	Anamorphic	4 Magnetic	Curved
G-2403	.715 x .715 Sq. Corners	2:1	None	Anamorphic	4 Magnetic	Flat
G-2412	.715 x .650 Sq. Corners	2:1	Width	Anamorphic	4 Magnetic	Flat
G-2414	.650 x .780 Sq. Corners	2.35:1	Width & Height	Anamorphic	Mag Optical	Curved
G-2436	.715 x .839 Sq. Corners	2.35:1	None	Anamorphic	Mag Optical	Flat
G-2468	.715 x .780 Sq. Corners	2.35:1	Width	Anamorphic	Mag Optical	Flat
G-2513	.715 x .715 Sq. Corners	2:1	None	Anamorphic	Mag Optical	Flat
G-2514	.715 x .650 Sq. Corners	2:1	Width	Anamorphic	Standard Optical	Flat
G-2515	.650 x .650 Sq. Corners	2:1	Width & Height	Anamorphic	Standard Optical	Curved
G-2475	BLANK		FOR SPECIAL RATIOS OR CONDITIONS			

\*To correct Keystone.

\*\*These parts are not furnished with G-2613 and must be ordered separately.

G-2613 CURVED FILM TRAP PARTS

G-2616 Aperture Plate Tension Spring and Plate  
 G-4167 Guide Roller and Shaft (Fixed Roller)

CP-156 Pressure Strap Tension Spring Cam Adjusting Locking Ball

HP-129 Locking Ball Pressure Spring

H-2519 Pressure Strap Fastening Screw (4)  
 H-2520 Threading Guide-Light Shield Fastening Screw (7)  
 H-3107 Adjustment Cam-Cam Shaft Knob Fastening Pin (6)  
 H-3108 Cam Shaft Knob Stop-Pressure Strap Anchor Pin (5)  
 H-3218 Gap Adjusting Screw Fastening Nut  
 H-3707 Locking Ball Pressure Spring & Ball Retainer Screw

P-1433 Gap Adjusting Screw  
 P-1435 Guide Roller Pivot Set Screw (2)  
 P-1556 Film Trap Fastening Screw Retaining Ring  
 P-1698 Guide Roller Shaft Pivot (2)  
 P-1700 Guide Roller Washer Retainer Ring  
 P-1701 Guide Roller Compression Spring  
 P-1702 Guide Roller Washer  
 P-1757 Pressure Block Fastening Screw (2)  
 P-1773 Aperture Plate Tension Spring & Plate Fast'g Screw (2)  
 P-1981 Film Trap Fastening Screw  
 P-4069 Pressure Strap Support  
 P-4071 Threading Guide  
 P-4072 Pressure Strap Arm Button (2)  
 P-4073 Pressure Strap Arm (2)  
 P-4074 Pressure Strap Arm Pivot Shaft  
 P-4075 Pressure Strap Arm Mounting Block  
 P-4076 Tension Spring Adjusting Cam Shaft  
 P-4077 Tension Spring Adjusting Cam Shaft Knob  
 P-4078 Pressure Strap (2)  
 P-4079 Pressure Strap Flat Tension Spring  
 P-4080 Curved Film Trap  
 P-4084 Light Shield  
 P-4089 Tension Spring Adjusting Cam Shaft Retaining Ring  
 P-4090 Pressure Strap Arm Pivot Shaft Retaining Ring (2)  
 P-4092 Pressure Strap Tension Spring Adjusting Cam  
 P-4166 Movable Guide Roller  
 P-4209 Long Aperture Plate Guide  
 P-4210 Short Aperture Plate Guide

Allen Wrench No.

Required for

P-2725  
 P-2794

P-1435  
 H-3707

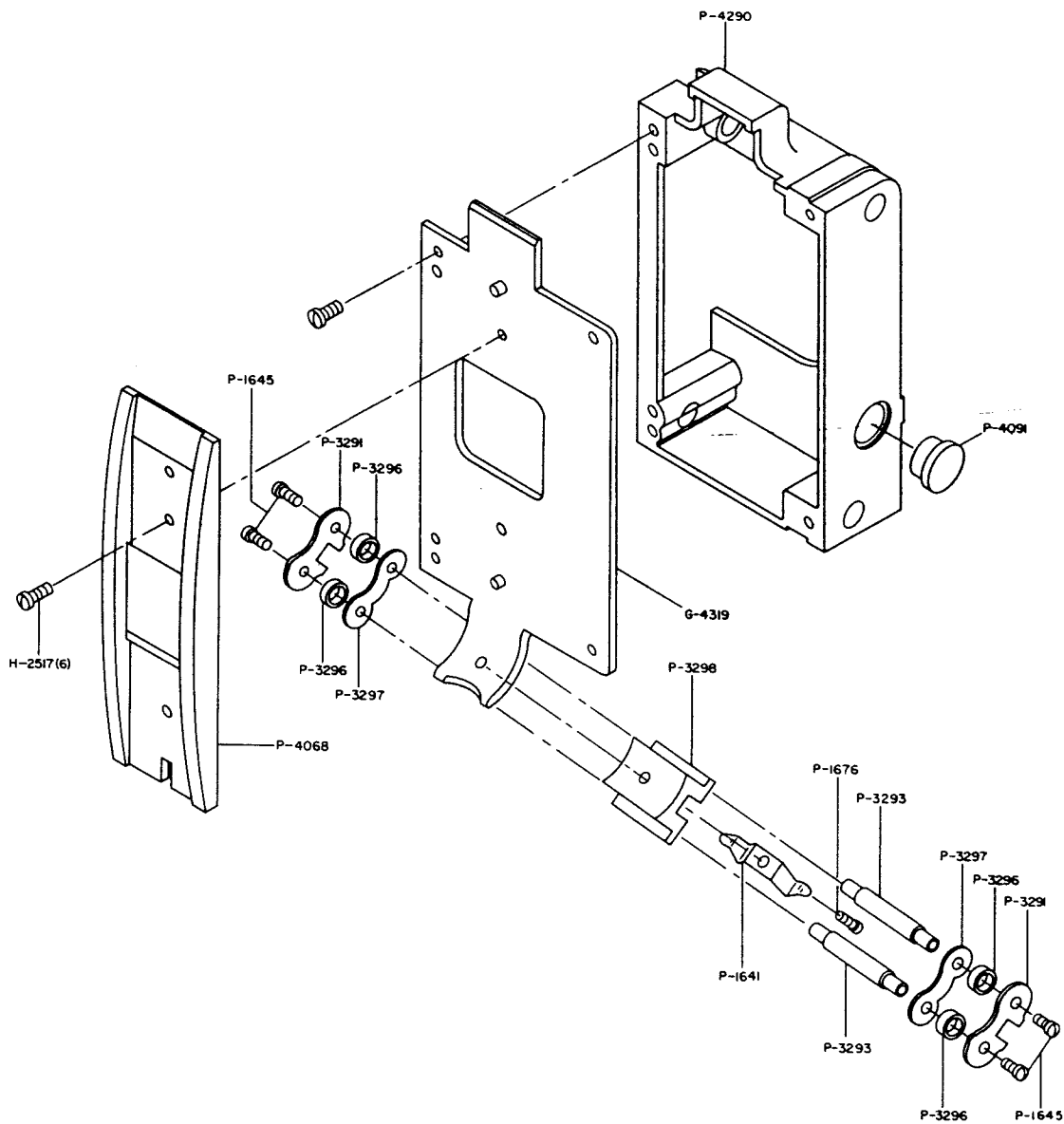

G-4318 CURVED FILM TRAP GATE PARTS

- G-4319 Door and Pin Assy (G-2622 on Mechanisms below 10,000)
- H-2517 Screw (6) (P-1663 on Mechanisms below 10,000)
- P-1641 Tension Shoe Pressure Spring
- P-1645 Tension Shoe Stud Fastening Screw (4)
- P-1676 Tension Shoe Spring Fastening Screw
- P-3291 Outer Tension Shoe (2)
- P-3293 Tension Shoe Stud (2)
- P-3296 Tension Shoe Spacer (4)
- P-3297 Inner Tension Shoe (2)
- P-3298 Tension Shoe Spacer Block
- P-4068 Runner
- P-4091 Cover Plug
- P-4290 Cover (P-1664 on Mechanisms below 10,000)

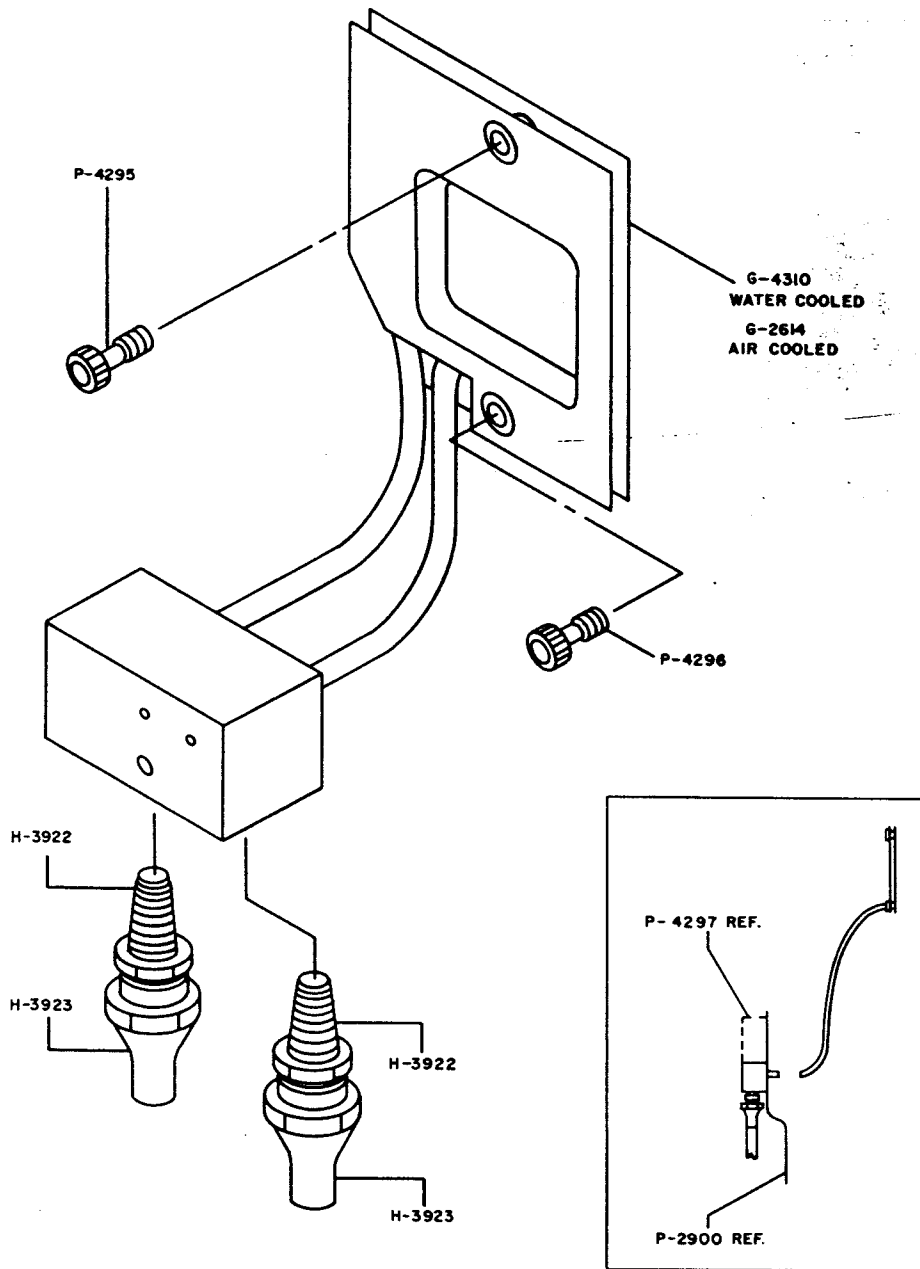

G-4310 WATER COOLED HEAT SHIELD PARTS

G-4310 Water Cooled Heat Shield (G-2614 Air Cooled)

H-3922 Water Tubing Connector (2)

H-3923 Water Tubing Connector Nut (2)

P-4295 Heat Shield Upper Fastening Screw

P-4296 Heat Shield Lower Fastening Screw

Allen Wrench No.

P-2794

Required for

P-4295, P-4296

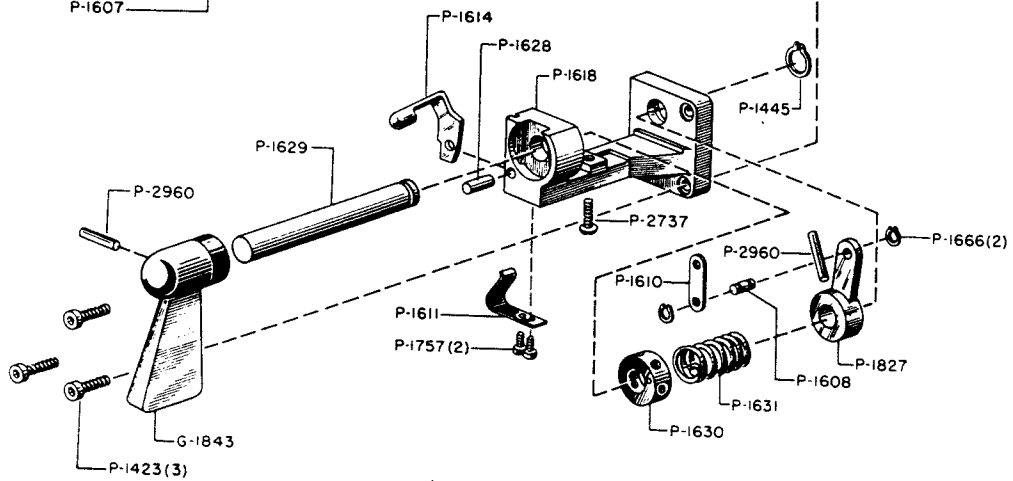
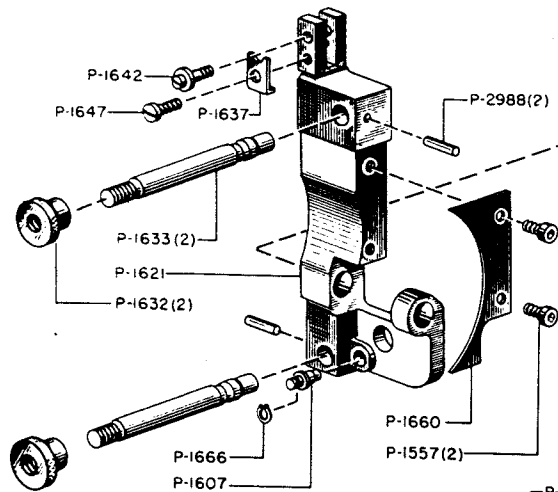
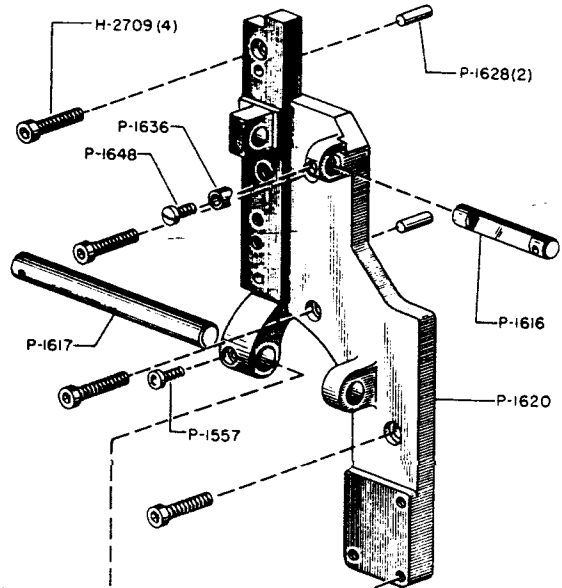
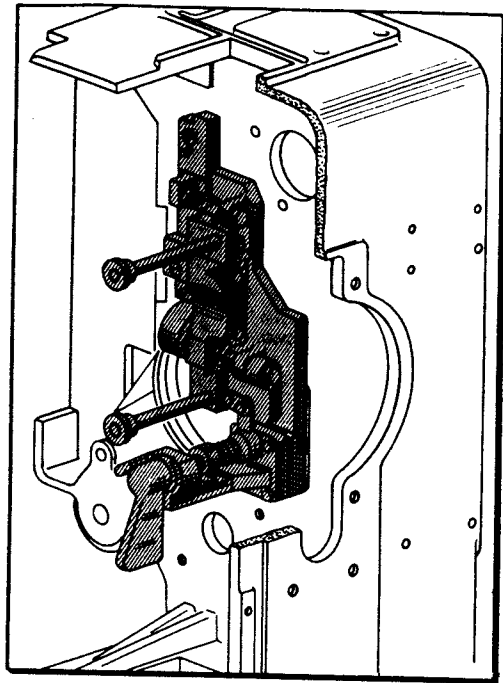

G-1905 FILM TRAP AND DOOR MOUNTING AND OPERATING ASSEMBLY

G-1905 FILM TRAP AND DOOR MOUNTING  
AND OPERATING ASSEMBLY PARTS

- G-1843 Operating Lever (Order G-1863)  
 \*G-1850 Support Bracket and Studs  
 \*\*G-1863 Operating Lever, Shaft and Collar  
 \*\*\*H-2709 Support Bracket Fastening Screw (4)  
 P-1423 Operating Lever Mounting Bracket Fastening Screw (3)  
 P-1445 Operating Lever Shaft Retaining Ring  
 P-1557 Light Shield-Lower Guide Rod Fastening Screw (3)  
 P-1607 Collar Link Stud  
 P-1608 Operating Lever Link Stud  
 P-1610 Operating Lever Collar Link  
 P-1611 Release Lever Tension Spring  
 P-1614 Release Lever  
 P-1616 Upper Guide Rod  
 P-1617 Lower Guide Rod  
 P-1618 Operating Lever Mounting Bracket  
 P-1620 Support Bracket  
 P-1621 Film Trap Door Support Bracket (Order G-1850)  
 P-1628 Support Bracket-Release Lever Pin (3)  
 P-1629 Operating Lever Shaft (Order G-1863)  
 P-1630 Spring Tension Adjusting Collar  
 P-1631 Operating Lever Tension Spring  
 P-1632 Knurled Fastening Nut (2)  
 P-1633 Support Stud (2) (Order G-1850)  
 P-1636 Upper Guide Rod Clamp  
 P-1637 Friction Adjusting Screw Clamp  
 P-1642 Upper Guide Rod Friction Adjusting Screw  
 P-1647 Friction Adjusting Screw Clamp Fastening Screw  
 P-1648 Upper Guide Rod Clamp Fastening Screw  
 P-1660 Light Shield  
 P-1666 Operating Lever Link Retaining Ring (3)  
 P-1757 Release Lever Tension Spring Fastening Screw (2)  
 P-1827 Operating Lever Collar Arm (Order G-1863)  
 P-2737 Adjusting Collar Retaining Screw  
 P-2960 Operating Lever-Collar Pin (2) (Order G-1863)  
 P-2988 Support Stud Pin (2)

\*Includes P-1607, P-1621, P-1633 (2) and P-2988 (2), P-1621 and P-1633 cannot be replaced separately.

\*\*Includes G-1843, P-1629, P-1827 and P-2960 (2) which cannot be replaced separately.

\*\*\*This part is not furnished with G-1905 and must be ordered separately.

Allen Wrench No.

Required for

P-1395  
 P-2711  
 P-2794

P-1423, P-1557  
 H-2709  
 P-1757

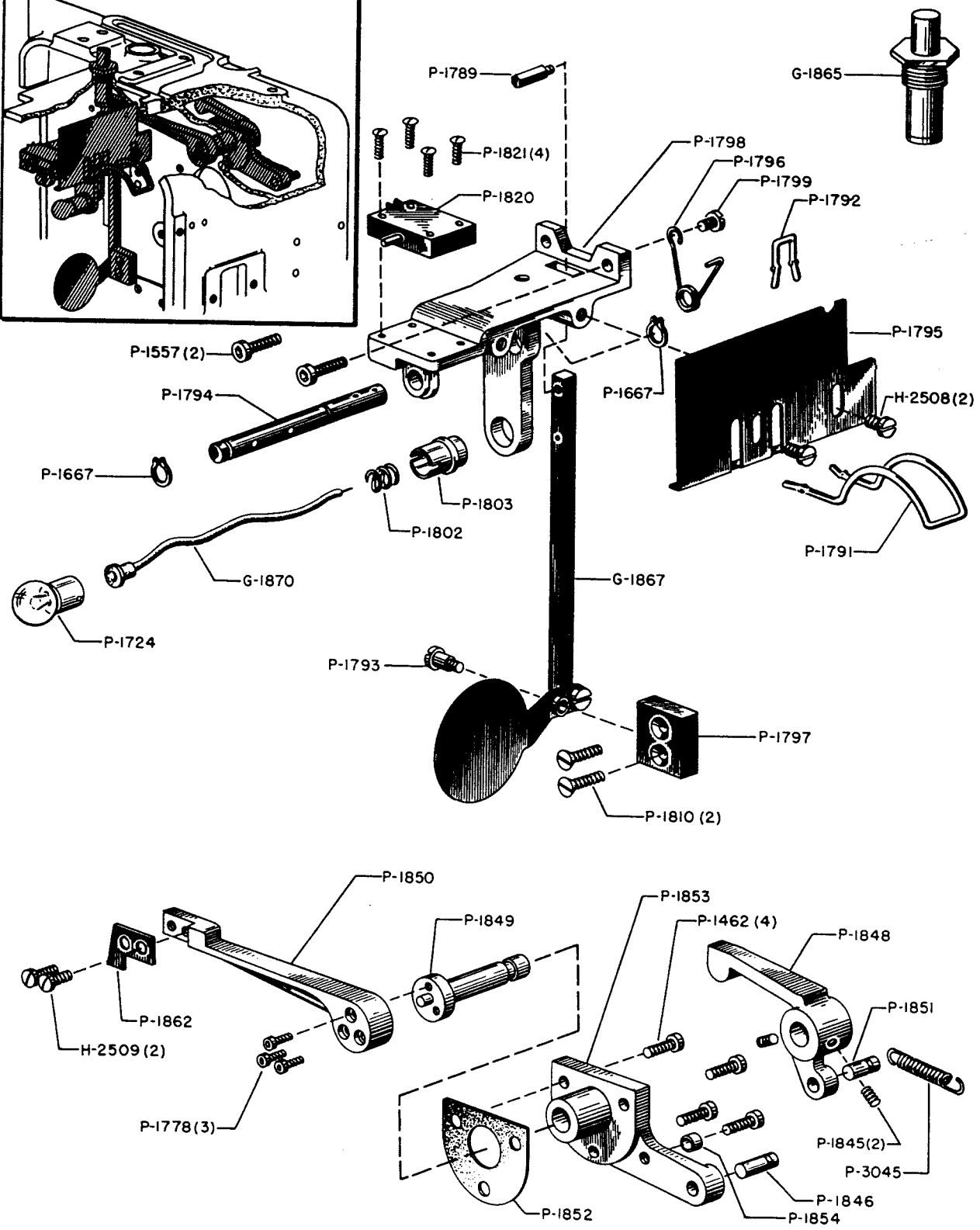
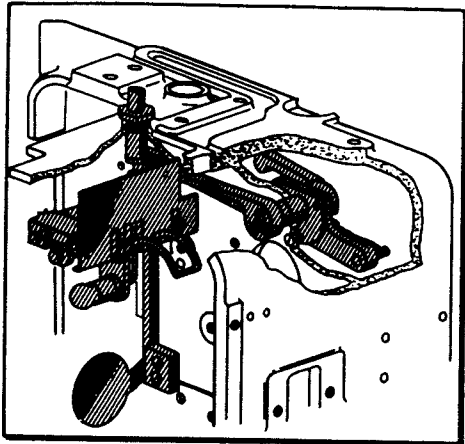

FIRE SHUTTER

FIRE SHUTTER PARTS

G-1865 Re-Set Button  
 G-1867 Fire Shutter and Rod  
 G-1870 Framing Lamp Socket Contact and Wire  
  
 H-2508 Partition Plate Fastening Screw (2)  
 H-2509 Operating Arm Adjusting Plate Fastening Screw (2)  
  
 P-1462 Support Bracket-Cam Fastening Screw (4)  
 P-1557 Mounting Bracket Fastening Screw (2)  
 P-1667 Trip Lever Shaft Retaining Ring (2)  
 P-1724 Framing Lamp, 6-8V  
 P-1778 Operating Arm Fastening Screw (3)  
 P-1789 Re-Set Stud  
 P-1791 Film Operated Trip Lever  
 P-1792 Fire Shutter Trip Lever  
 P-1793 Fire Shutter Pivot Screw  
 P-1794 Trip Lever Shaft  
 P-1795 Partition Plate  
 P-1796 Re-Set Spring  
 P-1797 Pivot Mounting Block  
 P-1798 Mounting Bracket  
 P-1799 Re-Set Spring Fastening Screw  
 P-1802 Lamp Socket Contact Spring  
 P-1803 Lamp Socket  
 P-1810 Mounting Block Fastening Screw (2)  
 P-1820 Framing Lamp Switch, SPST  
 P-1821 Framing Lamp Switch Fastening Screw (4)  
 P-1845 Governor Operated Arm Set Screw (2)  
 P-1846 Support Bracket Stud  
 P-1848 Governor Operated Arm  
 P-1849 Operating Arm Shaft  
 P-1850 Operating Arm  
 P-1851 Governor Operated Arm Stud  
 P-1852 Support Bracket Gasket  
 P-1853 Support Bracket  
 P-1854 Adjusting Cam  
 P-1862 Operating Arm Adjusting Plate  
 P-3045 Governor Operated Arm Spring

Allen Wrench No.

Required for

P-1395  
 P-2710

P-1462, P-1557, P-1845  
 P-1778



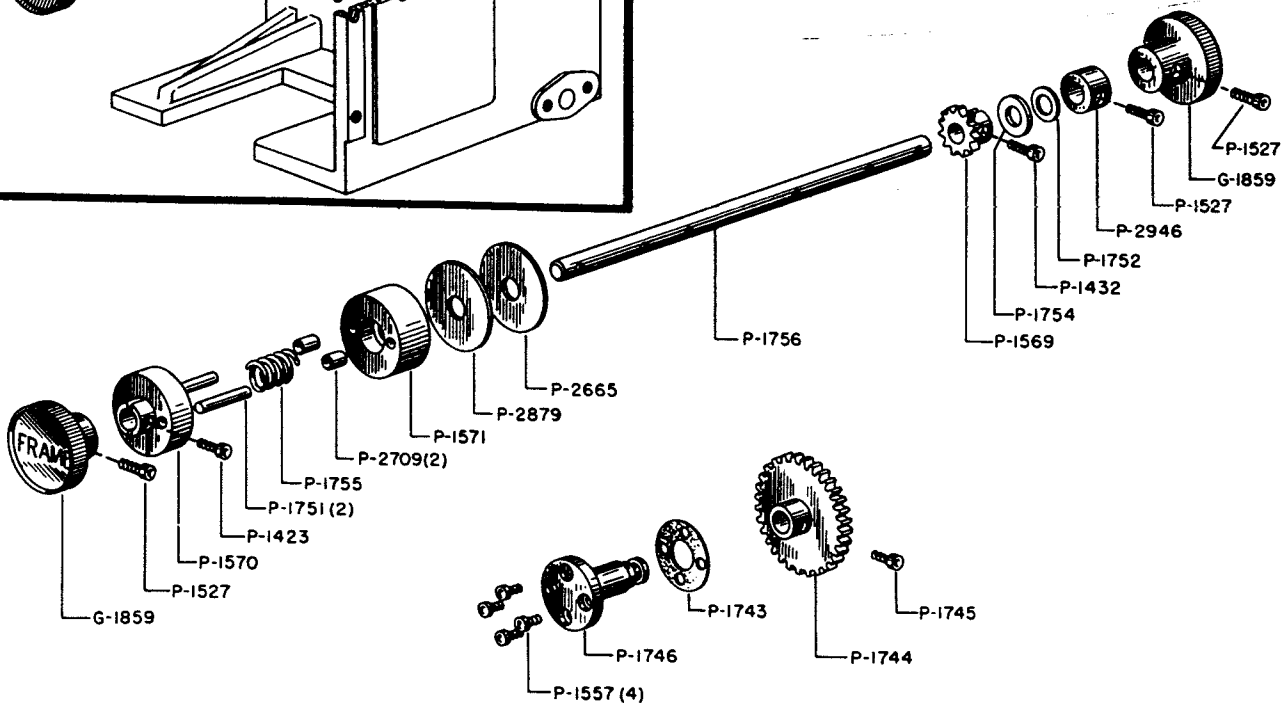
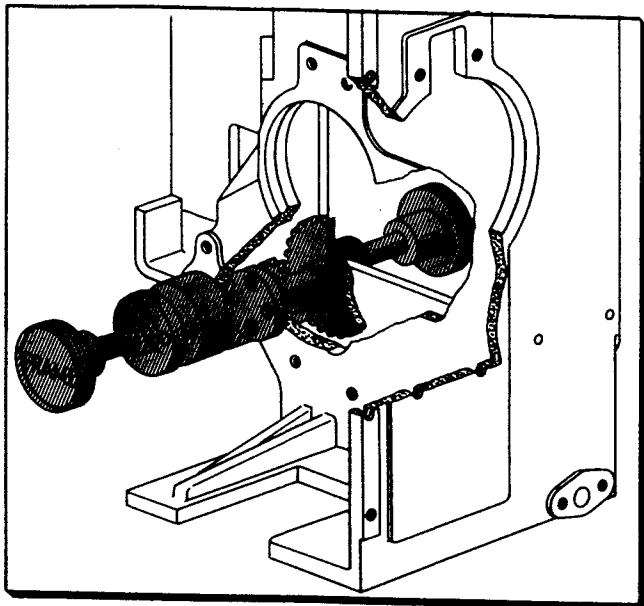

**FRAMING ASSEMBLY**

- |  |   |
|--|---|
| G-1859 Framing Knob (2)                        | P-1745 Idler Gear Fastening Screw         |
| P-1423 Friction Flange Fastening Screw         | P-1746 Idler Gear Shaft                   |
| P-1432 Framing Gear Fastening Screw            | P-1751 Friction Disc Pin (2)              |
| P-1527 Framing Knob-Collar Fastening Screw (3) | P-1752 Framing Shaft Friction Disc Washer |
| P-1557 Idler Gear Shaft Fastening Screw (4)    | P-1754 Framing Shaft Gasket               |
| P-1569 Framing Gear                            | P-1755 Framing Shaft Friction Spring      |
| P-1570 Friction Flange                         | P-1756 Framing Knob Shaft                 |
| P-1571 Friction Disc                           | P-2665 Oil Seal Washer                    |
| P-1743 Idler Gear Shaft Gasket                 | P-2709 Friction Disc-Flange Spacer (2)    |
| P-1744 Idler Gear                              | P-2879 Friction Washer                    |
|  | P-2946 Framing Handle Collar              |

Allen Wrench No.

- P-1395
- P-2711

Required for

- P-1423, P-1432, P-1557
- P-1527

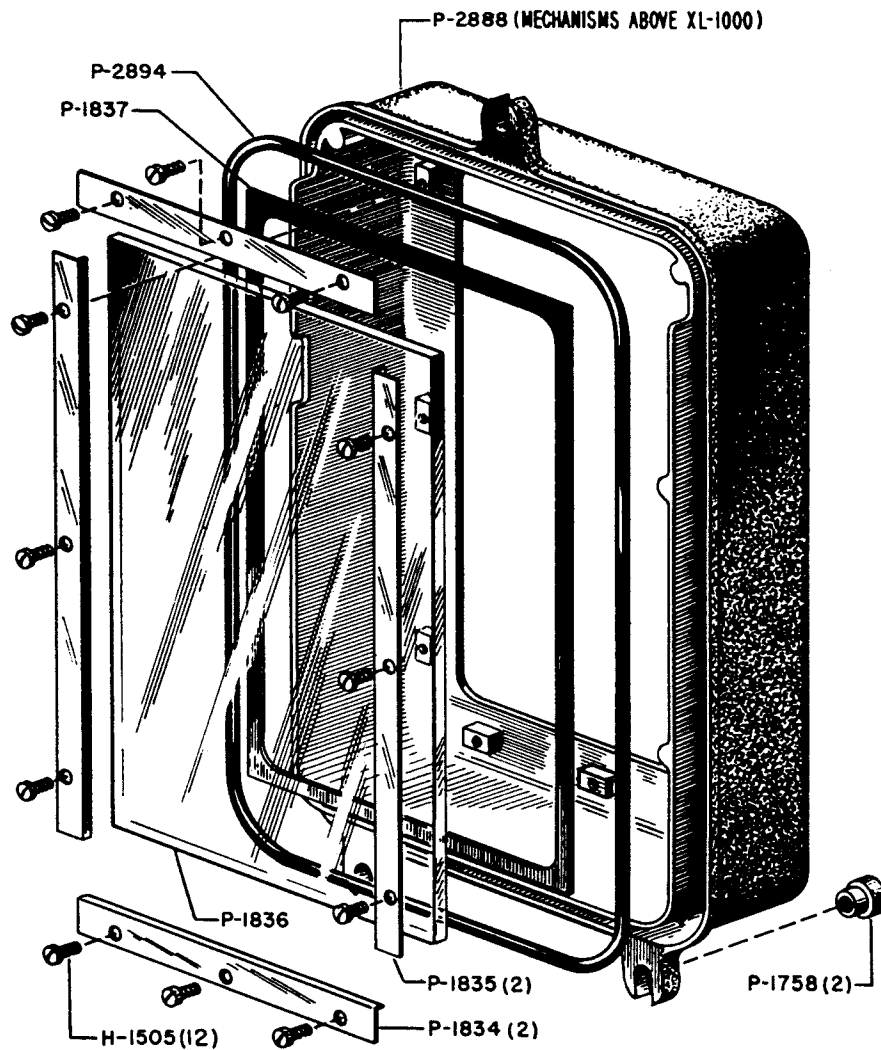

GEAR COMPARTMENT DOOR

- H-1505 Retaining Strip Fastening Screw (12)
- P-1758 Door Knurled Fastening Nut (2)
- P-1834 Horizontal Glass Retaining Strip (2)
- P-1835 Vertical Glass Retaining Strip (2)
- P-1836 Door Glass
- P-1837 Glass Gasket
- P-2888 Gear Compartment Door (Mechanisms above XL-1000)
- P-2894 Door Gasket

P-2890(MECHANISMS ABOVE XL-1000)

P-1557 (5)

P-1555

P-1277(2)

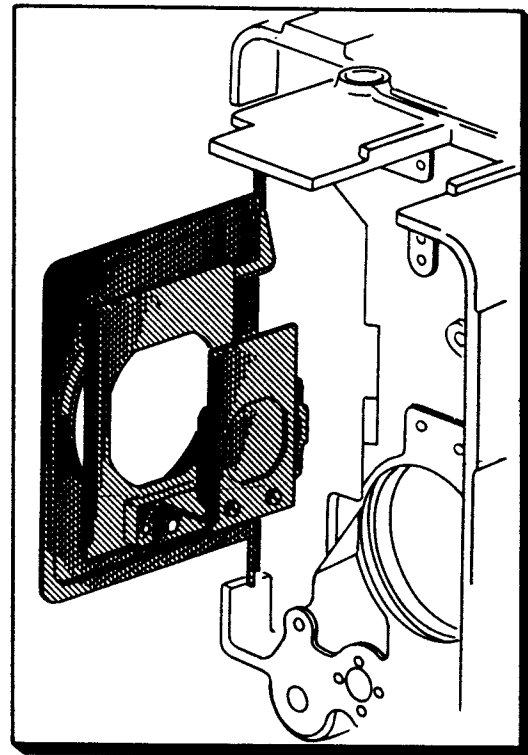

H-3218 (2)

H-3328(2)

P-3625

P-3314

P-1974 (2)

P-1990

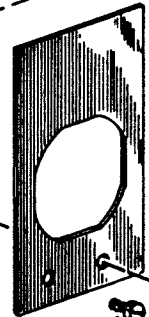
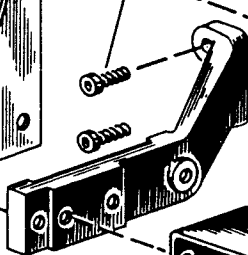
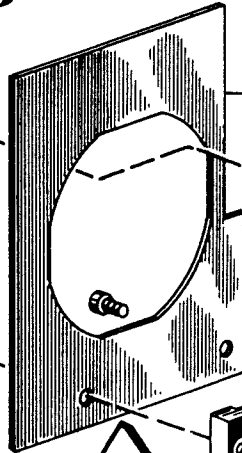
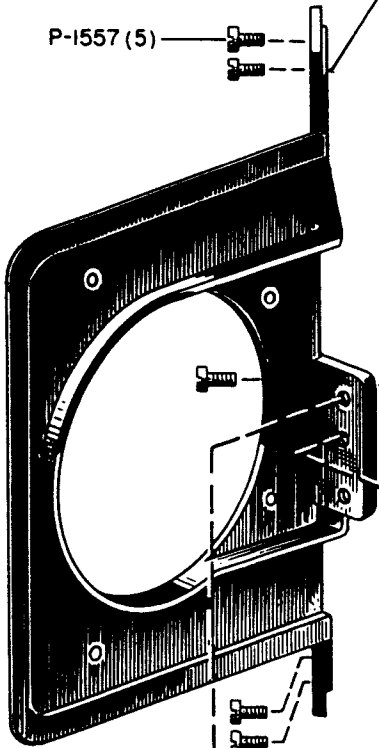

P-1527(2)

P-1985

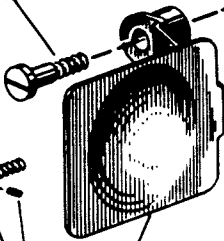

P-2015

G-1910

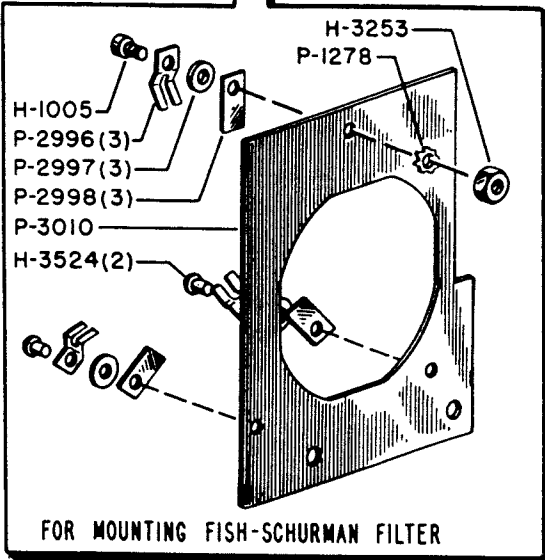

H-3253

P-1278

H-1005

P-2996 (3)

P-2997 (3)

P-2998 (3)

P-3010

H-3524(2)

H-1544(2)

P-3312

P-1527(2)

P-1983

FOR MOUNTING FISH-SCHURMAN FILTER

HEAT SHIELD AND DOWSER

### HEAT SHIELD AND DOWSER PARTS

G-1910 Dowser

\*H-1005 Clip Fastening Screw  
 H-1544 Front Heat Shield Fastening Screw (2)  
 H-3218 Dowser Stop Plate Fastening Nut (2)  
 \*H-3253 Clip Fastening Nut  
 H-3328 Dowser Stop Plate Fastening Nut Washer (2)  
 \*H-3524 Clip Rivet (2)

P-1277 Dowser Pivot Screw Fastening Nut (2)  
 \*P-1278 Clip Lockwasher  
 P-1527 Rear Heat Shield-Mounting Bracket Fastening Screw (4)  
 P-1555 Dowser Pivot Screw Fastening Nut Lockwasher  
 P-1557 Rear Cover Fastening Screw (5)  
 P-1974 Support Bracket Fastening Screw (2)  
 P-1983 Front Heat Shield Mounting Bracket  
 P-1985 Dowser Pivot Screw  
 P-1990 Heat Shield Support Bracket  
 P-2015 Dowser Cable Pivot Clamp and Set Screws  
 P-2890 Rear Cover (Mechanisms above XL-1000)  
 \*P-2996 Heat Filter Retaining Clip (3)  
 \*P-2997 Spacer Washer (3)  
 \*P-2998 Clip Spacer (3)  
 \*P-3010 Rear Heat Shield  
 P-3312 Front Heat Shield  
 P-3314 Rear Heat Shield  
 P-3625 Dowser Stop Plate

\*Heat Shield and Parts to Mount Fish-Schurman Heat Filter.

Allen Wrench No.

Required for

P-1395  
 P-2711

P-1557  
 P-1527, P-1974

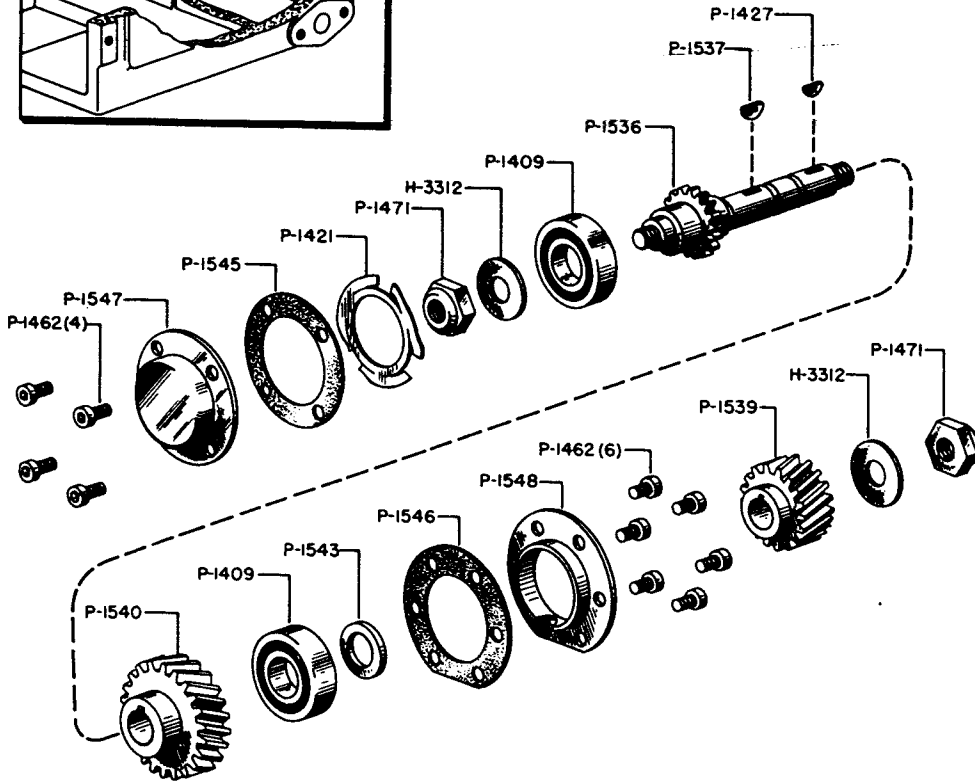
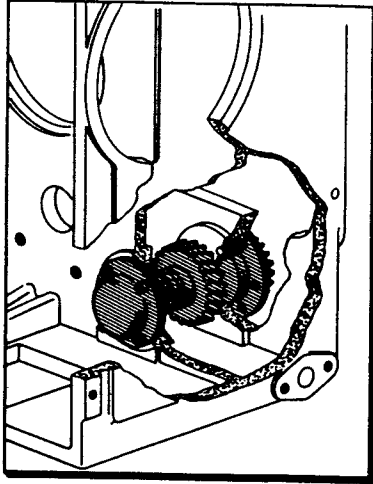

HORIZONTAL MAIN DRIVE

- |        |                         |         |   |
|--------|-------------------------|---------|---|
| H-3312 | Bearing Washer (2)      | P-1536  | Main Drive Shaft and Gear                               |
| P-1409 | Ball Bearing (2)        | P-1537  | Vertical Shaft Drive Gear Key                           |
| P-1421 | Spring Loading Washer   | *P-1539 | Projector Main Drive Gear<br>(Simplex Sound Mechanisms) |
| P-1427 | Main Drive Gear Key     | P-1540  | Vertical Shaft Drive Gear                               |
| P-1462 | Cover-Retainer Ring     | P-1543  | Ball Bearing Thrust Washer                              |
|        | Fastening Screw (10)    | P-1545  | Ball Bearing Cover Gasket                               |
| P-1471 | Ball Bearing-Drive Gear | P-1546  | Retainer Gasket   |
|        | Retainer Nut (2)        | P-1547  | Ball Bearing Cover                                      |
|        |                         | P-1548  | Ball Bearing Retainer                                   |

\*Projector Main Drive Gears used with other Soundheads are shown as part of the Drive Kit.

Allen Wrench No.

P-1395

Required for

P-1462

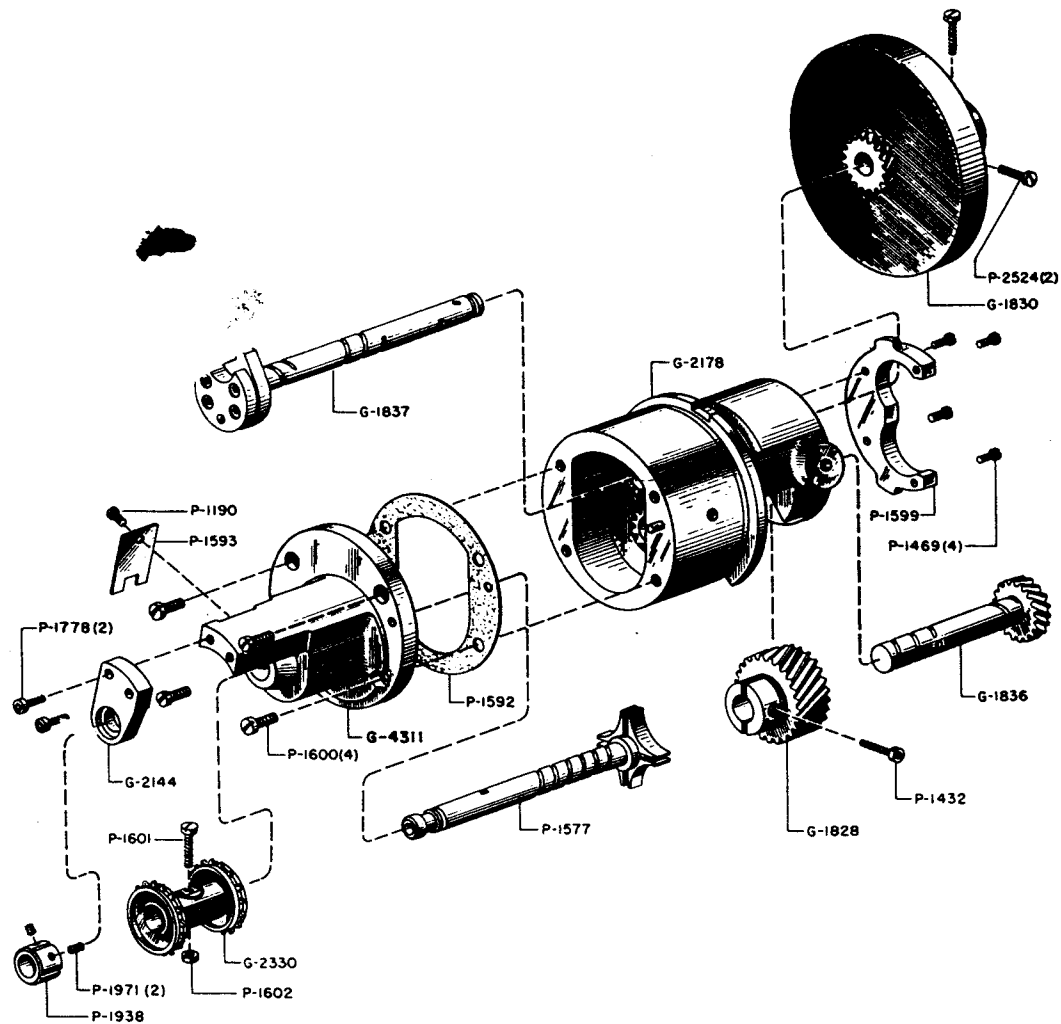

G-4312 INTERMITTENT ASSEMBLY (REGULAR)

G-1828	Main Drive Gear	P-1577	Starwheel
G-1830	Intermittent Flywheel and Gear	P-1592	Cover Gasket
G-1836	Main Drive Shaft and Gear	P-1593	Stripper Plate
G-1837	Cam, Pin and Flywheel Shaft	P-1500	Oil Trap
G-2144	Front Bearing Plate	P-1600	Cover Fastening Screw (4)
G-2178	Intermittent Case and Bearings	P-1601	Sprocket Fastening Screw
G-2330	Intermittent Sprocket	P-1602	Sprocket Fastening Nut
G-4311	Intermittent Cover	P-1778	Front Bearing Plate Fastening Screw (2)
P-1190	Stripper Plate Fastening Screw	P-1938	Starwheel Shaft Collar
P-1432	Intermediate Gear Fastening Screw	P-1971	Collar Set Screw (2)
P-1469	Oil Trap Fastening Screw (4)	P-2524	Flywheel Fastening Screw (2)

Allen Wrench No.

P-1395  
P-2710  
P-2726

Required for

P-1432  
P-1778  
P-1971

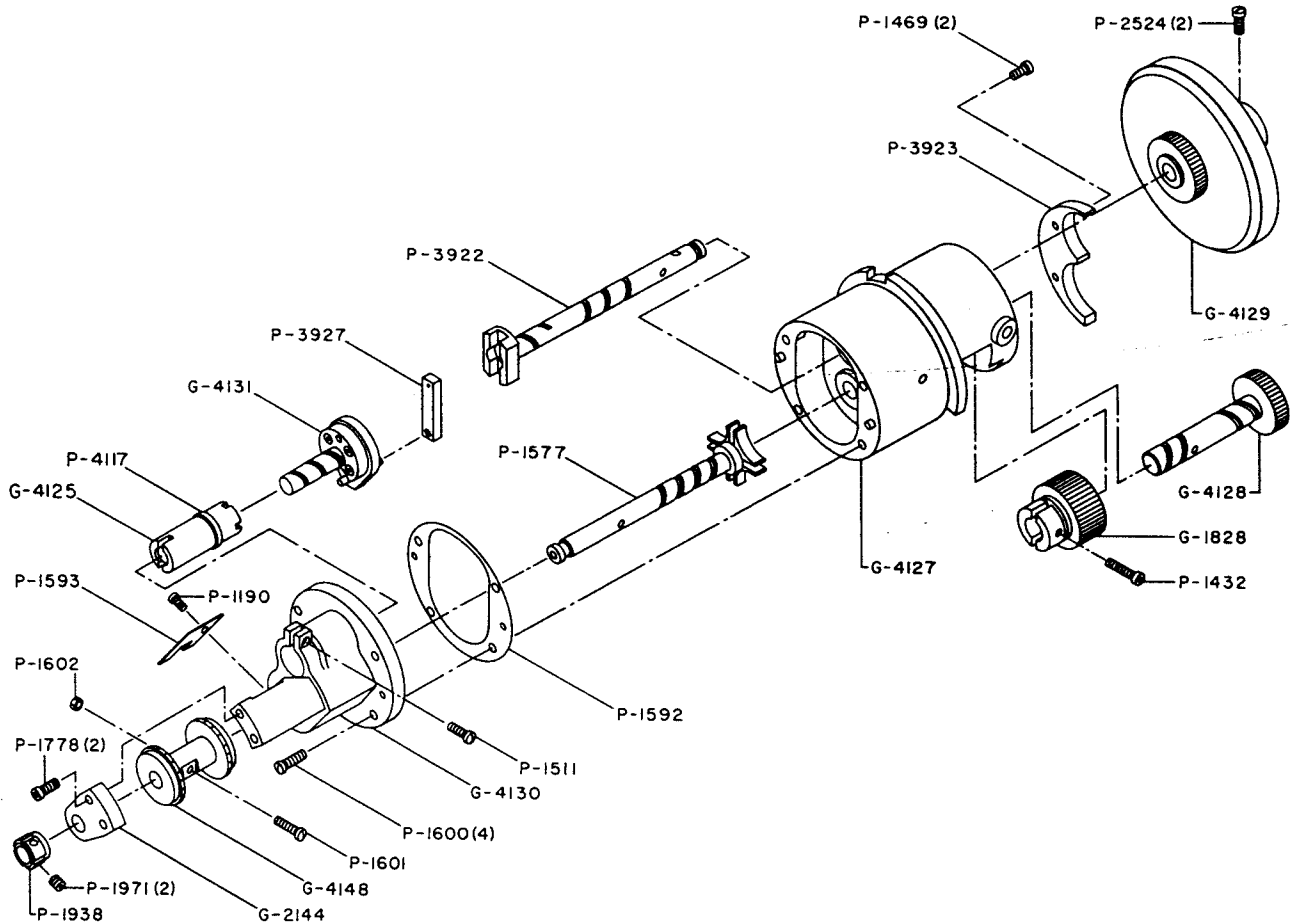

**G-4126 INTERMITTENT ASSEMBLY (HI-SPEED)**

- |        |  |        |   |
|--------|--|--------|---|
| G-1828 | Main Drive Gear                                      | P-1577 | Starwheel                               |
| G-2144 | Front Bearing Plate                                  | P-1592 | Cover Gasket                            |
| G-4125 | Intermittent Cam Eccentric Bearing (Includes P-3928) | P-1593 | Stripper Plate                          |
| G-4127 | Intermittent Case and Bearings                       | P-1600 | Cover Fastening Screw (4)               |
| G-4128 | Main Drive Shaft and Gear                            | P-1601 | Sprocket Fastening Screw                |
| G-4129 | Intermittent Flywheel and Gear                       | P-1602 | Sprocket Fastening Nut                  |
| G-4130 | Intermittent Cover                                   | P-1778 | Front Bearing Plate Fastening Screw (2) |
| G-4131 | Intermittent Cam, Pin and Plate                      | P-1938 | Starwheel Shaft Collar                  |
| G-4148 | Intermittent Sprocket (Includes P-1601 and P-1602)   | P-1971 | Collar Set Screw (2)                    |
| P-1190 | Stripper Plate Fastening Screw                       | P-2524 | Flywheel Fastening Screw (2)            |
| P-1432 | Main Drive Gear Fastening Screw                      | P-3922 | Flywheel Shaft and Slide Guide          |
| P-1469 | Oil Trap Fastening Screw (2)                         | P-3923 | Oil Trap                                |
| P-1511 | Cam Bearing Clamp Fastening Screw                    | P-3927 | Cam Driving Slide                       |
|        |  | P-3928 | Cam Bearing Oil Plug                    |
|        |  | P-4117 | Cam Bearing Outer Oil Seal - "O" Ring   |

Allen Wrench No.

Required for

- P-1395
- P-2710
- P-2726

- P-1432
- P-1778
- P-1971

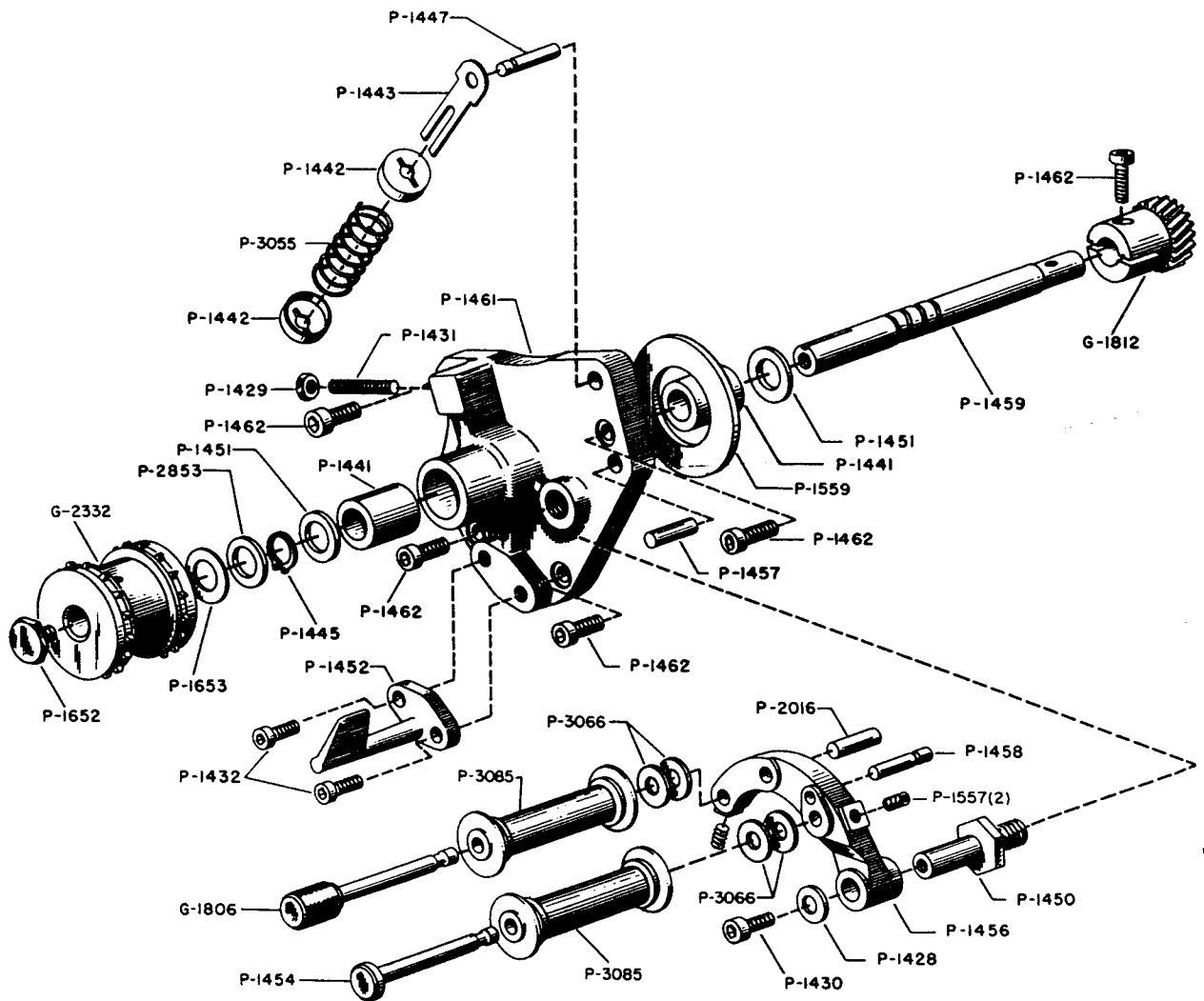

G-1809 LOWER FEED SPROCKET PARTS

G-1806	Pad Roller Knob and Stud	P-1454	Pad Roller Stud
G-1812	Drive Gear	P-1456	Pad Roller Arm
G-2332	Sprocket and Key Pin	P-1457	Pad Roller Travel Limit Pin
P-1428	Pad Roller Arm Washer	P-1458	Pad Roller Arm Spring Guide Retainer Pin
P-1429	Pad Roller Adjustment Lock Nut	P-1459	Sprocket Shaft
P-1430	Pad Roller Arm Fastening Screw	P-1461	Mounting Bracket
P-1431	Pad Roller Arm Adjusting Screw	P-1462	Drive Gear Fastening Screw
P-1432	Stripper Fastening Screw (2)	*P-1462	Mtg Bracket Fastening Screw (4)
P-1441	Sleeve Bearing (2)	P-1557	Pad Roller Stud Set Screw (2)
P-1442	Pad Roller Arm Spring Retainer (2)	*P-1559	Mounting Bracket Gasket
P-1443	Pad Roller Arm Spring Guide	P-1652	Sprocket Retaining Screw
P-1445	Bearing Washer Retaining Ring	P-1653	Spring Washer
P-1447	Pad Roller Arm Spring Guide Pin	P-2016	Pad Roller Arm Stop Pin
P-1450	Pad Roller Arm Pivot Stud	P-2853	Bearing Washer
P-1451	Bearing Washer (2)	P-3055	Pad Roller Arm Spring
P-1452	Stripper Plate	P-3066	Pad Roller Spacing Washer (4)
		P-3085	Pad Roller (2)

\*These parts are not furnished with G-1809 and must be ordered separately.

Allen Wrench No.

P-1395

P-2711

P-2794

Required for

P-1432, P-1462, P-1557

P-1430

P-1431



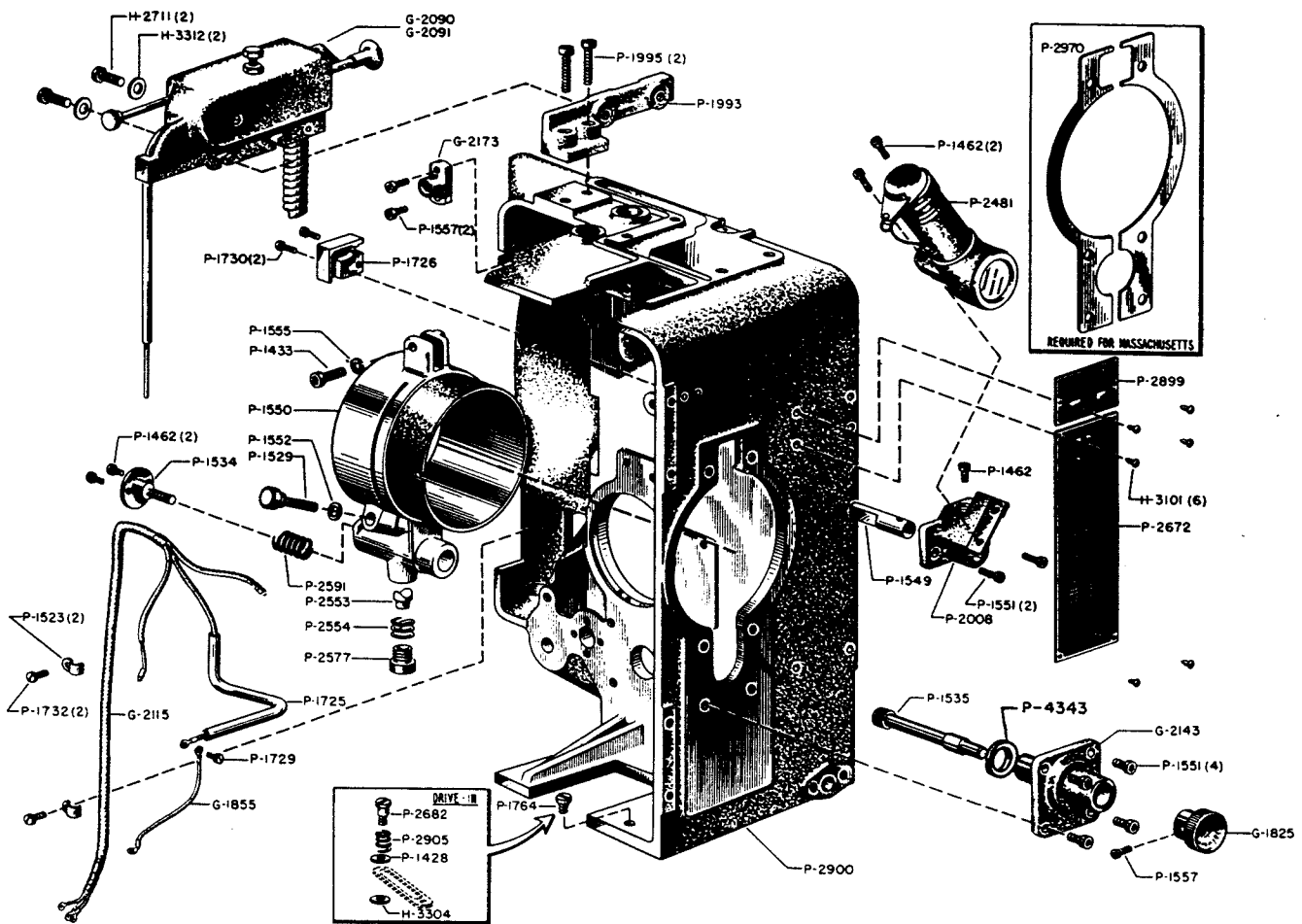

**\*G-2335 4" ANAMORPHIC  
LENS SUPPORT**

- \*P-3304 Lens Support Roller Stud
- \*P-3305 Upper Lens Holder Guide
- \*P-3306 Lens Support Roller
- \*P-3307 Lens Support Ring-Guide and Support Rod
- \*P-3308 Lens Support Ring
- \*P-3309 Upper Lens Guide-Screen Scope Mounting Bracket
- \*P-3544 Lens Support Rod Stop Screw
- \*P-1462 Screen Scope-Lens Holder Guide Lens Support Rod-Bracket Mounting Screw (6)
- \*P-1527 Lens Support Clamping Screw

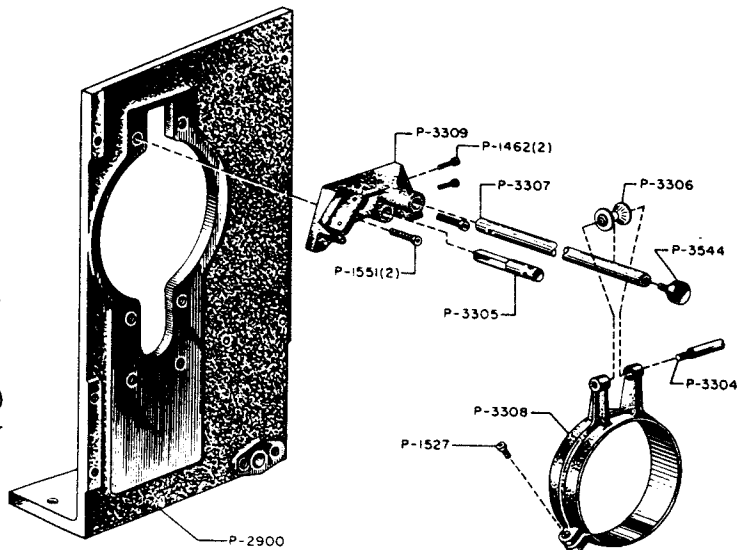

\*Not part of Main Frame and Lens Holder Parts and must be ordered separately.

**MAIN FRAME AND LENS HOLDER**

MAIN FRAME AND LENS HOLDER PARTS

G-1825	Lens Focusing Knob	P-1550	Lens Holder
G-1855	Threading Lamp Connecting Wire	P-1551	Lens Holder-Guide Bracket Fastening Screw (6)
*G-2090	Projector Changeover, 115 Volts AC	P-1552	Lens Holder Clamping Screw Washer
*G-2091	Projector Changeover, 115 Volts DC	P-1555	Clearance Adjusting Screw Lockwasher
G-2115	Cable Form	P-1557	Bracket-Knob Fastening Screw (3)
G-2143	Lower Lens Holder Guide Bracket and Sleeve	P-1725	Insulating Tubing
G-2173	Spot Sight Box Fastening Screw Bracket	P-1726	Connection Block
		P-1729	Connection Screw
		P-1730	Connection Block Fastening Screw (2)
		P-1732	Cable Clamp Fastening Screw (2)
H-2711	Changeover Fastening Screw (2)	P-1764	Door Stay Fastening Screw
H-3101	Patent-Nameplate Fastening Screw (6)	P-1993	Changeover Mounting Bracket
H-3304	Door Stay Lower Washer (Drive-In Theaters)	P-1995	Changeover Bracket Fastening Screw (2)
H-3312	Changeover Fastening Screw Washer (2)	P-2008	Upper Lens Holder Guide-Screen Scope Mounting Bracket
P-1428	Door Stay Upper Washer (Drive-In Theaters)	P-2481	Screen Scope
		P-2553	Lens Holder Adjustment Clamp
		P-2554	Clamping Screw Spring
		P-2577	Lens Holder Adjustment Clamping Screw
		**P-2591	Focusing Knob Shaft Spring
P-1433	Lens Holder Guide Clearance Adjusting Screw	P-2672	Patent Plate
P-1462	Screen Scope-Lens Holder Guide Flange Fastening Screw (5)	P-2682	Door Stay Fastening Screw (Drive-In Theaters)
P-1523	Cable Clamp (2)	P-2899	Nameplate
P-1529	Lens Holder Clamping Screw	P-2900	Main Frame
P-1534	Focusing Flanged Screw	P-2905	Door Stay Compression Spring (Drive-In Theaters)
P-1535	Focusing Knob Shaft	***P-2970	Lens Holder Opening Guard (Mass.)
P-1549	Upper Lens Holder Guide	P-4343	Washer, Spacer

\*See page 2-6 for parts.

\*\*Not used when P-1535 Shaft has Split Thread.

\*\*\*Part of G-2193 Adapter Kit.

Allen Wrench No.

P-1395  
P-2711  
P-2712

Required for

P-1462, P-1557  
P-1433  
H-2711, P-1551, P-1995

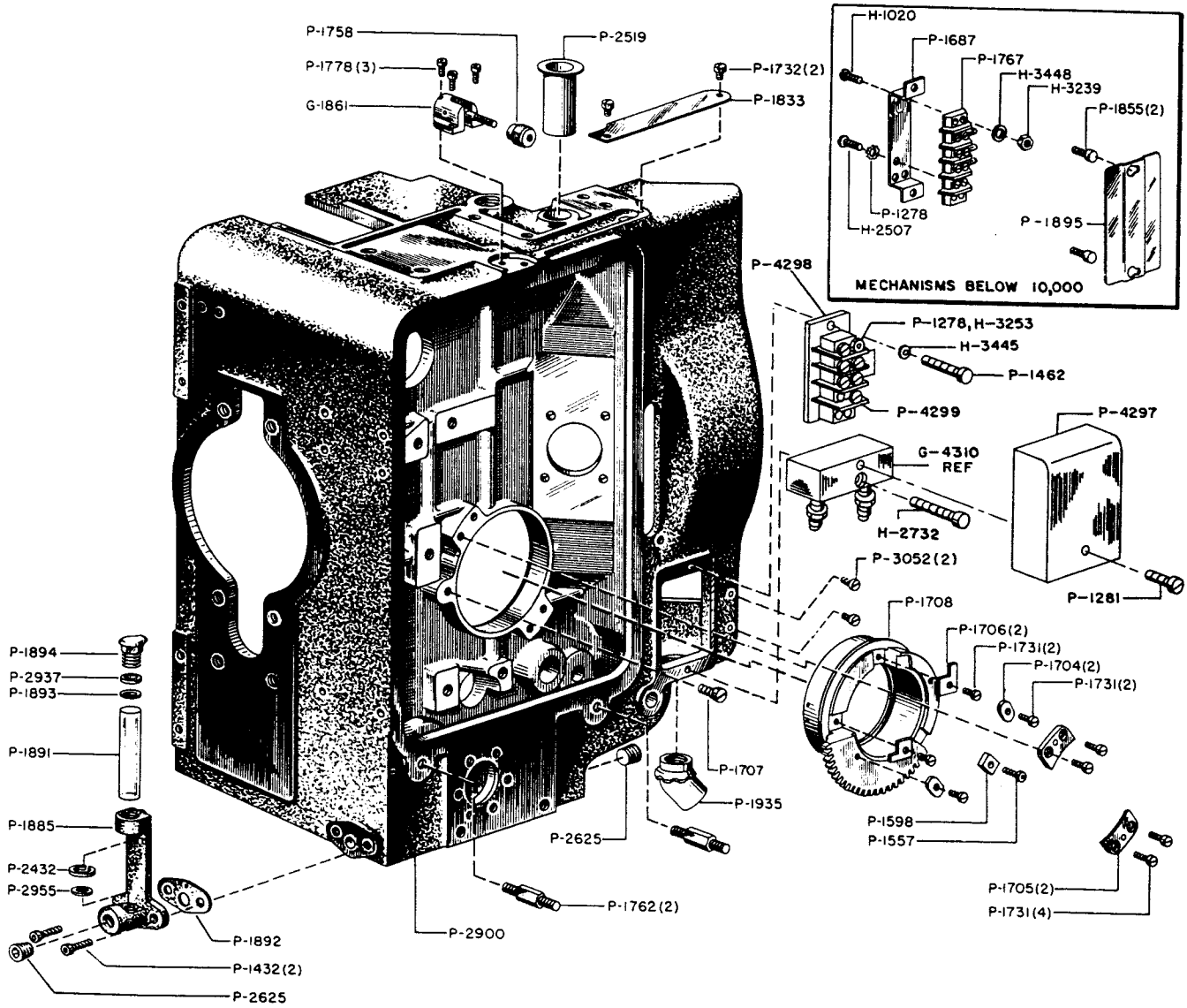
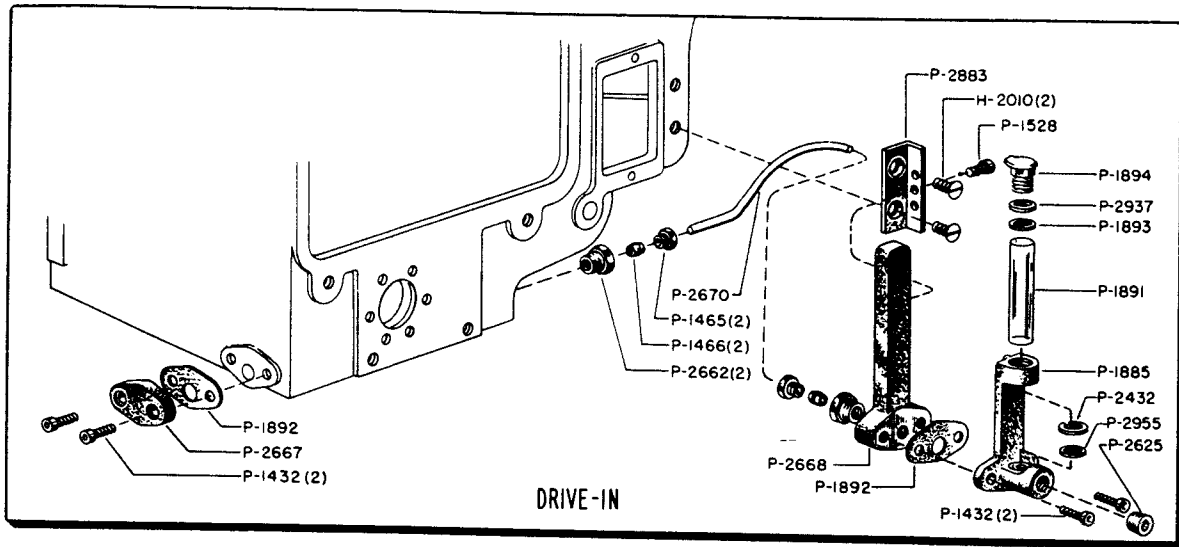

MAIN FRAME, OIL GAUGE AND FRAMING CAM  
ASSEMBLY PARTS

G-1861	Gear Compartment Door Swivel Fastening Stud	P-1708	Framing Cam
*G-1891	Oil Gauge Assembly	P-1731	Framing Cam-Intermittent Retaining Clip Fastening Screw (8)
**G-4310	Water Cooled Heat Shield Assembly	P-1732	Wire Channel Cover Plate Fastening Screw (2)
H-1020	Terminal Strip Upper Fastening Screw	P-1758	Gear Compartment Cover Fastening Nut (3)
H-2010	Oil Gauge Mounting Bracket Fastening Screw (Drive-In Theaters) (2)	P-1762	Gear Compartment Cover Mounting Stud (2)
H-2507	Terminal Strip Lower Fastening Screw	P-1767	Terminal Strip
H-2732	Junction Block Fastening Screw	P-1778	Swivel Fastening Stud Mounting Screw (3)
H-3239	Terminal Strip Fastening Nut	P-1833	Wire Channel Cover Plate
H-3253	Terminal Strip Fastening Screw (2)	P-1855	Terminal Strip Cover Fastening Screw (2)
H-3445	Terminal Strip Bracket Lockwasher (2)	P-1885	Oil Gauge Bracket
H-3448	Terminal Strip Washer	P-1891	Gauge Glass
P-1278	Terminal Strip Lockwasher (2)	P-1892	Oil Hole Cover Gasket
P-1281	Connection Box Cover Fastening Screw	P-1893	Upper Gauge Glass Gasket
P-1432	Oil Hole Cover-Oil Gauge Fastening Screw (2)	P-1894	Oil Cup
P-1462	Terminal Strip Bracket Fastening Screw	P-1935	45° Angle Connector
P-1465	Compression Nut (Drive-In Theaters) (2)	P-2432	Oil Level Ring
P-1466	Compression Bushing (Drive-In Theaters) (2)	P-2519	Oil Deflector
P-1528	Oil Gauge Mounting Plate Fastening Screw (Drive-In Theaters)	P-2625	Oil Drain Plug
P-1557	Intermittent Locating Key Fastening Screw	P-2662	Oil Hole Adapter (Drive-In Theaters) (2)
P-1598	Intermittent Locating Key	P-2667	Oil Hole Cover (Drive-In Theaters)
P-1687	Terminal Strip Mounting Bracket	P-2668	Oil Gauge Mounting Plate (Drive-In Theaters)
P-1704	Intermittent Retaining Clip (2)	P-2670	Oil Gauge Tube (Drive-In Theaters)
P-1705	Framing Cam Retainer Plate (2)	P-2883	Oil Gauge Mounting Bracket (Drive-In Theaters)
P-1706	Framing Cam Stop Plate (2)	P-2895	Terminal Strip Cover
P-1707	Intermittent Stop Screw	P-2900	Main Frame
		P-2937	Gauge Glass Washer
		P-2955	Lower Gauge Glass Gasket
		P-3052	Oil Gauge Mounting Bracket Holes Plug Screws (2)
		P-4297	Connection Box Cover
		P-4298	Terminal Strip Bracket
		P-4299	Terminal Strip

\*Includes P-1885, P-1891, P-1893, P-1894, P-2432, P-2625, P-2937, P-2955.  
\*\*See Page 1-6 for parts.

Allen Wrench No.

P-1395  
P-2710  
P-2711

Required for

H-2732, P-1432, P-1462, P-1557  
P-1778  
P-1528

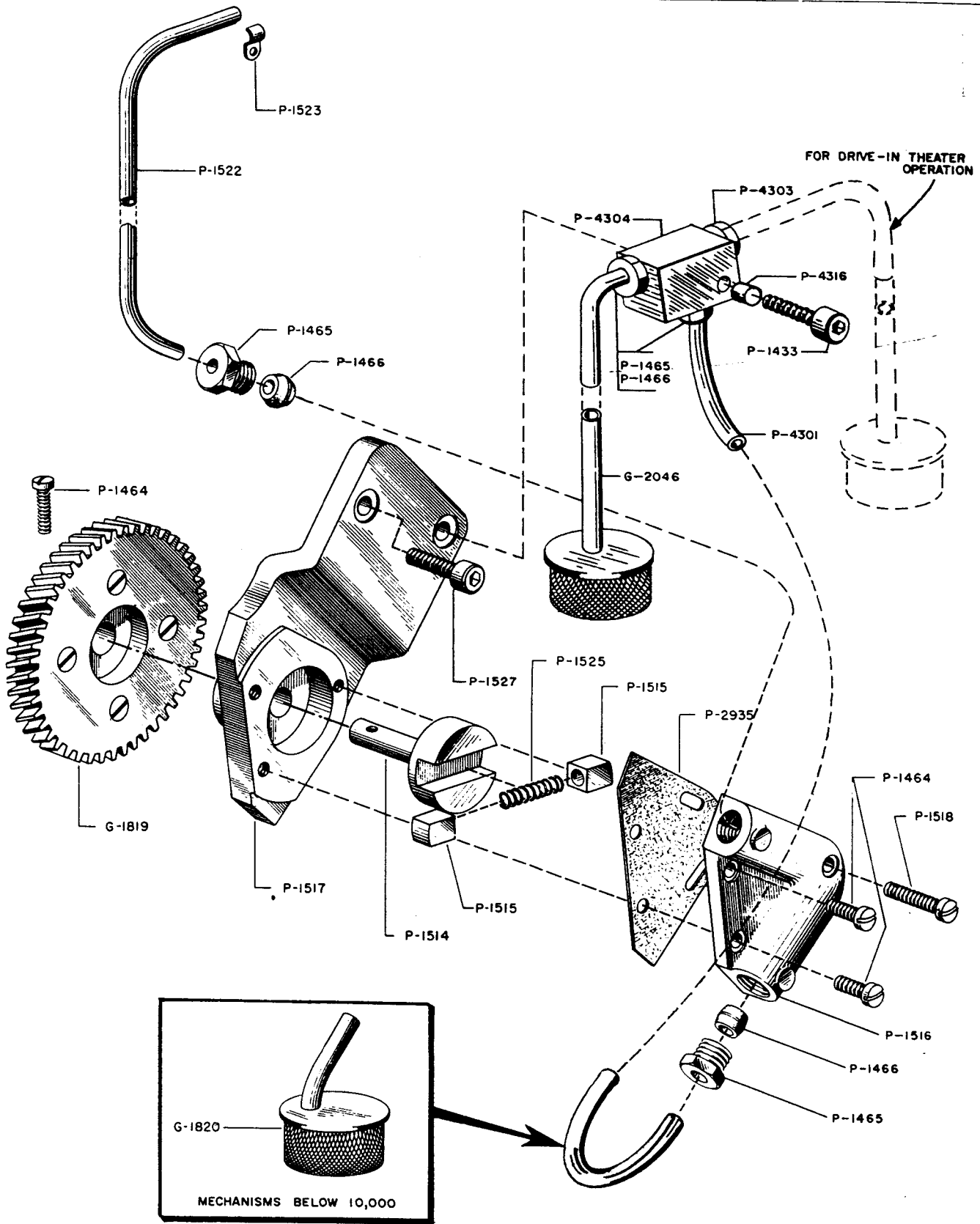

G-1822 OIL PUMP

G-1822 OIL PUMP PARTS

G-1819 Drive Gear  
G-1820 Filter and Oil Tube (Mechanisms below 10,000)  
G-2046 Filter and Oil Tube  
  
P-1433 Junction-3 Way Fastening Screw  
P-1464 Cover-Drive Gear Fastening Screw (Short) (3)  
P-1465 Compression Nut (4)  
P-1466 Compression Bushing (4)  
P-1514 Drive Shaft and Rotor  
P-1515 Vane (2)  
P-1516 Housing Cover  
P-1517 Housing  
P-1518 Cover Fastening Screw (Long)  
P-1522 Oil Tube  
P-1523 Oil Tube Clamp  
P-1525 Vane Spring  
P-1527 Pumping Fastening Screw  
P-2935 Cover Gasket  
P-4301 Connecting Oil Tube  
P-4303 Closure Plug  
P-4304 Junction-3 Way  
P-4316 Spacer (Junction Screw)

Allen Wrench No.

P-2711

Required for

P-1433, P-1527

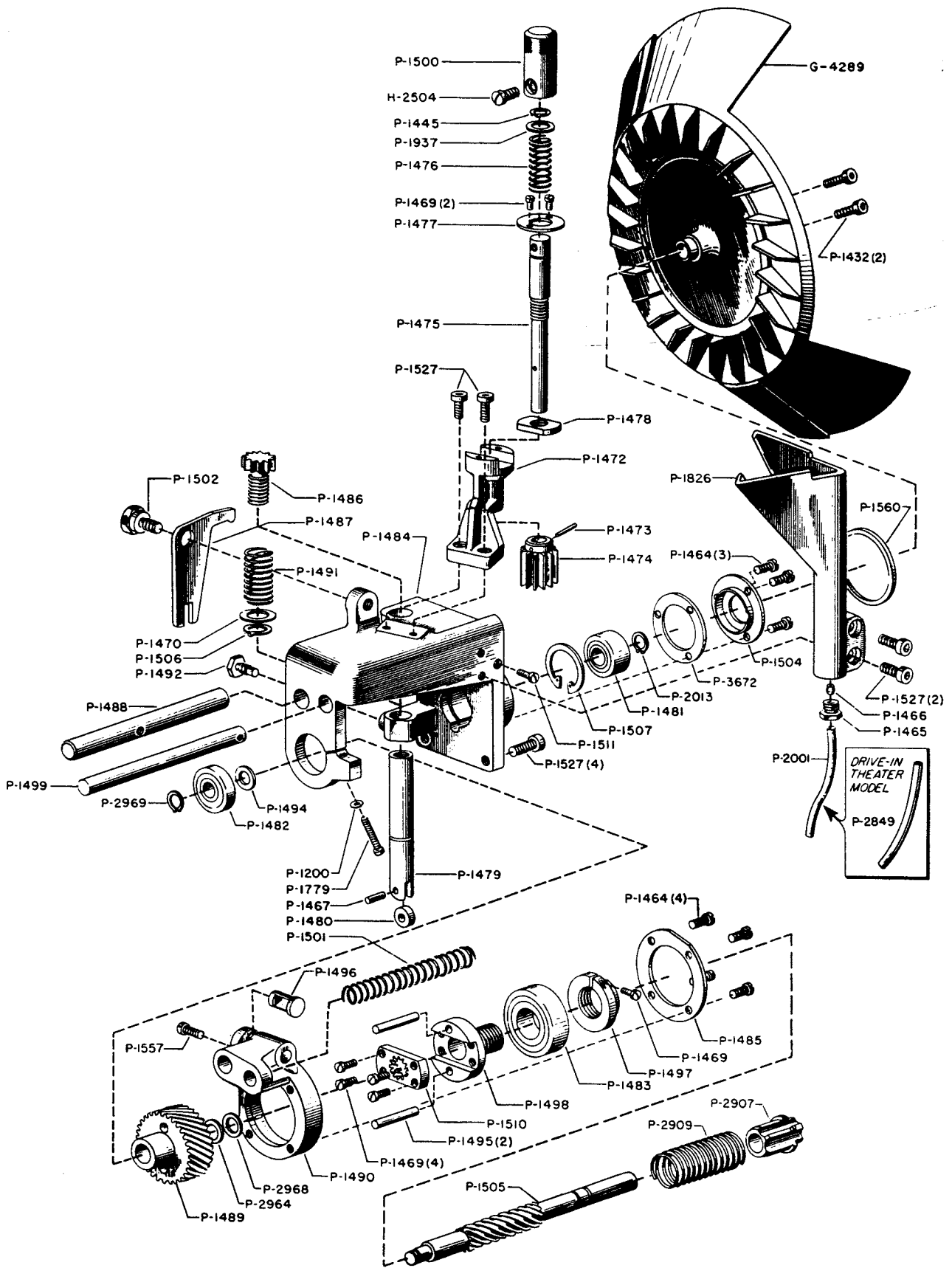

G-1815 SHUTTER AND FRAMING ASSEMBLY

G-1815 SHUTTER AND FRAMING ASSEMBLY PARTS

*G-4237	Shutter 3 Blade, 68° Movement	P-1488	Adjusting Spline Support Bracket Slide Rod
G-4289	Adjustable Shutter Assembly, 47° to 90°	P-1489	Shutter Shaft Drive Gear
H-2504	Shutter Adjusting Knob Fastening Screw	P-1490	Adjusting Spline Support Bracket
H-2523	Adjustable Shutter Screw (4)	P-1491	Framing Rod Compression Spring
H-3352	Adjustable Shutter Screw Washer (4)	P-1492	Framing Rod Guide Screw
P-1200	Ball Bearing Housing Clamping Screw Lockwasher	P-1494	Shutter Shaft Spacer
*P-1432	Shutter Clamping Screw (2)	P-1495	Shutter Shaft Driving Flange Pin (2)
P-1445	Shutter Adjusting Shaft Washer Retaining Ring	P-1496	Adjusting Lever Pin
P-1464	Ball Bearing Retaining Plate Fastening Screw (7)	P-1497	Spline Clamping Nut
*P-1465	Compression Nut	P-1498	Shutter Shaft Driving Flange
*P-1466	Compression Bushing	P-1499	Spline Support Bracket Guide Rod
P-1467	Framing Rod Roller Pin	P-1500	Shutter Adjusting Knob
P-1469	Stop Nut Retainer Plate-Spline Fastening and Clamping Nut	P-1501	Guide Rod Compression Spring
P-1470	Framing Rod Spring Retaining Washer	P-1502	Adjusting Lever Pivot Screw
P-1472	Shutter Adjusting Shaft Mounting Bracket	P-1504	Ball Bearing Outer Retainer Plate
P-1473	Shutter Adjusting Gear Pin	P-1505	Shutter Shaft
P-1474	Shutter Adjusting Gear	P-1506	Framing Rod Washer Retaining Ring
P-1475	Shutter Adjusting Shaft	P-1507	Rear Ball Bearing Inner Retaining Ring
P-1476	Shutter Adjusting Shaft Compression Spring	P-1510	Shutter Shaft Adjusting Spline
P-1477	Shutter Adjusting Shaft Stop Nut Retainer Plate	P-1527	Intermittent Oil Collector-Shaft Mtg. Bracket Fastening Screw (4)
P-1478	Shutter Adjusting Shaft Stop Nut	*P-1527	Shutter Shaft Mounting Bracket Fastening Screw (4)
P-1479	Framing Rod	P-1557	Slide Rod Fastening Screw
P-1480	Framing Rod Roller	*P-1560	Bracket Gasket
P-1481	Shutter Shaft Rear Ball Bearing	P-1779	Bearing Housing Clamping Screw
P-1482	Shutter Shaft Front Ball Bearing	P-1826	Intermittent Oil Collector
P-1483	Spline Ball Bearing	P-1937	Shutter Adjusting Shaft Compression Spring Washer
P-1484	Shutter Shaft Mounting Bracket	*P-2001	Intermittent Oil Tube
P-1485	Spline Ball Bearing Retaining Plate	P-2013	Rear Ball Rearing Outer Retaining Ring
P-1486	Framing Rod Screw Gear	*P-2849	Intermittent Oil Tube (Drive-In Theaters)
P-1487	Adjusting Lever	*P-2907	Shutter Shaft Spring Retaining Collar
		P-2909	Shutter Shaft Compression Spring
		P-2964	Shutter Shaft Loading Spring (Mechanisms above XL-1200)
		P-2968	Loading Spring Retaining Washer (Mechanisms above XL-1200)
		P-2969	Front Ball Bearing Outer Retaining Ring (Mechanisms above XL-1200)
		P-3672	Shutter Shaft Bracket Oil Seal Gasket (Rubber)

\*These parts are not furnished with G-1815 and must be ordered separately.

Allen Wrench No.

P-1395  
P-2711  
P-2725

Required for

P-1432, P-1557  
P-1527  
P-1779



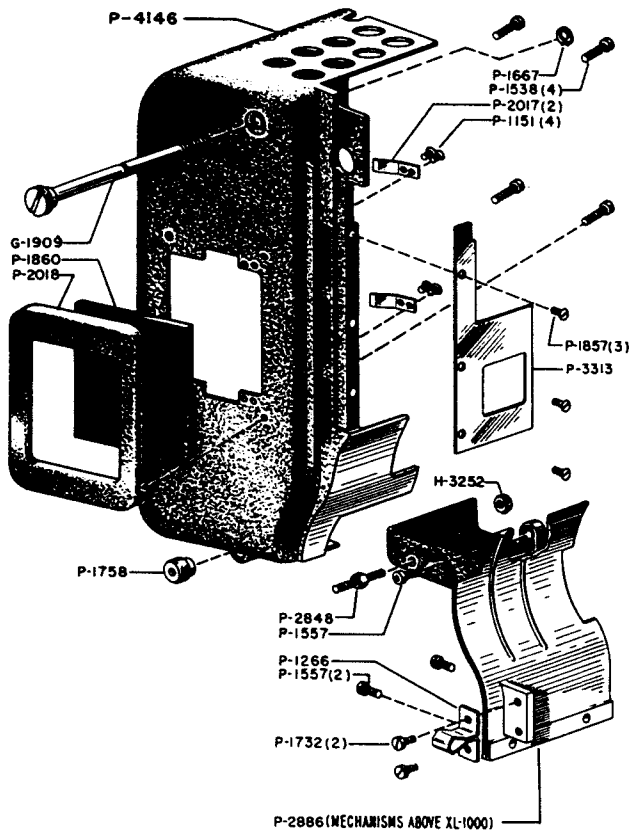

**SPOT SIGHT BOX AND LOWER REAR COVER**

- G-1909 Spot Sight Box Fastening Screw
- H-3252 Stud Fastening Nut
- P-1151 Window Retaining Spring Fastening Screw (4)
- P-1266 Film Compartment Door Strike
- P-1538 Window Frame Fastening Screw (4)
- P-1557 Cover Fastening Screw (3)
- P-1667 Sight Box Fastening Screw Retaining Ring
- P-1732 Door Strike Fastening Screw (2)
- P-1758 Spot Sight Box Fastening Nut
- P-1857 Heat Shield Fastening Screw (3)
- P-1860 Window Glass
- P-2017 Window Retaining Spring (2)
- P-2018 Window Frame
- P-2848 Spot Sight Box Fastening Stud
- P-2886 Lower Rear Cover (Mechanisms above XL-1000)
- P-4146 Spot Sight Box
- P-3313 Heat Shield

Allen Wrench No.  
P-1395

Required for  
P-1557

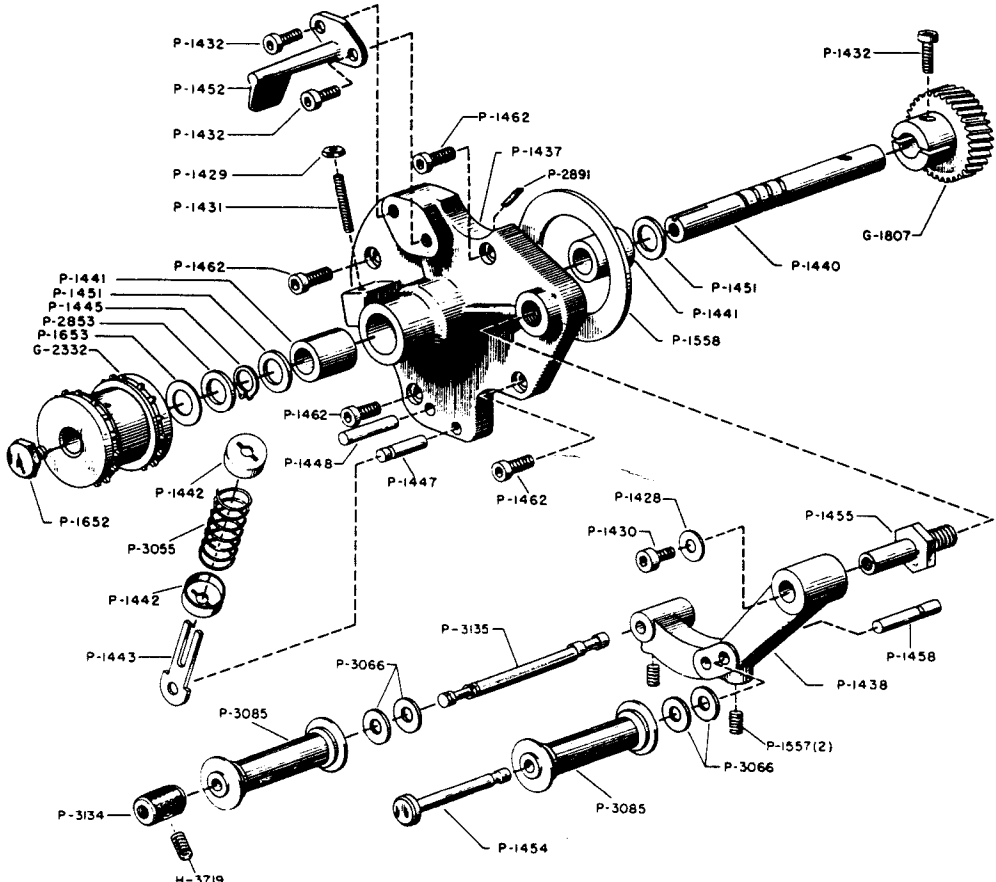

**G-1804 UPPER FEED SPROCKET**

G-1804 UPPER FEED SPROCKET PARTS

G-1807 Drive Gear  
 G-2332 Sprocket and Key Pin  
 H-3719 Pad Roller Stud Knob Set Screw  
 P-1428 Pad Roller Arm Washer  
 P-1429 Pad Roller Arm Adjustment Lock Nut  
 P-1430 Pad Roller Arm Fastening Screw  
 P-1431 Pad Roller Arm Adjusting Screw  
 P-1432 Stripper-Drive Gear Fastening Screw (3)  
 P-1437 Mounting Bracket  
 P-1438 Pad Roller Arm  
 P-1440 Sprocket Shaft  
 P-1441 Sleeve Bearing (2)  
 P-1442 Pad Roller Arm Spring Retainer (2)  
 P-1443 Pad Roller Arm Spring Guide  
 P-1445 Bearing Washer Retaining Ring  
 P-1447 Pad Roller Arm Spring Guide Pin  
 P-1448 Pad Roller Arm Travel Limit Pin  
 P-1451 Bearing Washer (2)  
 P-1452 Stripper Plate  
 P-1454 Pad Roller Stud  
 P-1455 Pad Roller Arm Pivot Stud  
 P-1458 Pad Roller Arm Spring Guide Retainer Pin  
 \*P-1462 Mounting Bracket Fastening Screw (4)  
 P-1557 Pad Roller Stud Set Screw (2)  
 \*P-1558 Mounting Bracket Gasket  
 P-1652 Sprocket Retaining Screw (4)  
 P-1653 Spring Washer  
 P-2853 Bearing Washer  
 P-2891 Bearing Wick  
 P-3055 Pad Roller Arm Spring  
 P-3066 Pad Roller Spacing Washer (4)  
 P-3085 Pad Roller (2)  
 P-3134 Pad Roller Stud Knob  
 P-3135 Pad Roller Stud (Eccentric)

\*These parts are not furnished with G-1804 and must be ordered separately.

Allen Wrench No.

Required for

P-1395  
 P-2711  
 P-2794

H-3719, P-1432, P-1462, P-1557  
 P-1430  
 P-1431

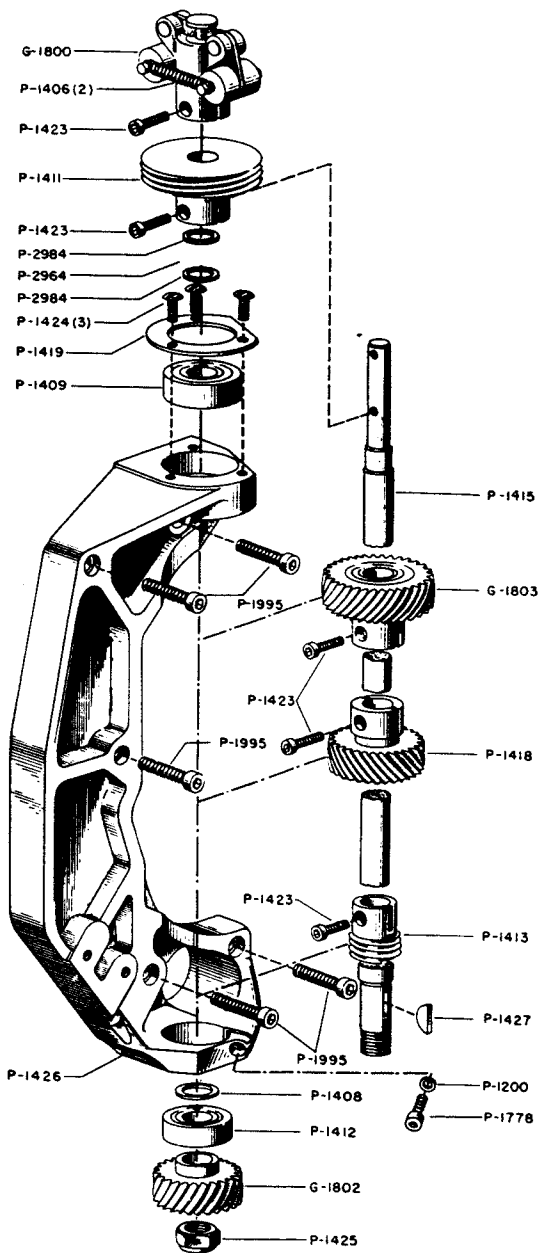

G-1801 VERTICAL SHAFT  
AND GOVERNOR

- G-1800 Governor Assembly (includes 2 P-1406)
- G-1802 Main Drive Gear
- G-1803 Shutter and Framing Assembly Drive Gear
  
- P-1200 Lower Ball Bearing Clamping Screw Lockwasher
- \*P-1406 Governor Spring (2)
- P-1408 Ball Bearing Retaining Washer
- P-1409 Upper Ball Bearing
- P-1411 Upper Feed Sprocket Assembly Drive Gear
- P-1412 Lower Ball Bearing
- P-1413 Lower Feed Sprocket Assembly Drive Gear
- P-1415 Vertical Shaft
- P-1418 Intermittent Assembly Drive Gear
- P-1419 Upper Ball Bearing Retaining Plate
- P-1423 Gear-Governor Fastening Screw (5)
- P-1424 Upper Ball Bearing Retainer Plate Fastening Screw (3)
- P-1425 Main Drive Gear Fastening Nut
- P-1426 Mounting Bracket
- P-1427 Main Drive Gear Key
- P-1778 Lower Ball Bearing Clamping Screw
- \*\*P-1995 Mounting Bracket Fastening Screw (5)
- P-2964 Loading Spring
- P-2984 Bearing-Gear Thrust Washer (2)

\*P-1406 is for individual replacement only. Two are furnished with G-1800 and G-1801.  
 \*\*This part is not furnished with G-1801 and must be ordered separately.

<u>Allen Wrench No.</u>	<u>Required for</u>
P-1395	P-1423
P-2710	P-1778

## SECTION II

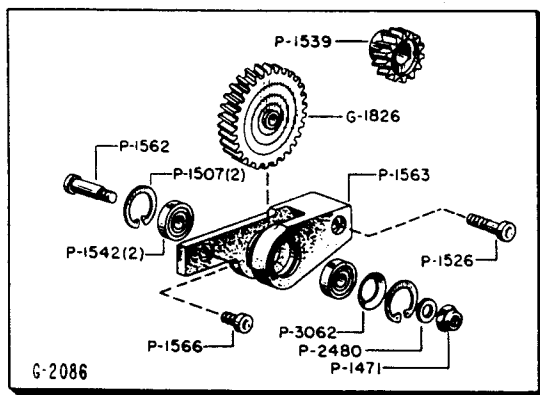

### G-2086 DRIVE KIT (Simplex Sound Mechanisms)

- |         |                                 |        |                                |
|---------|---------------------------------|--------|--------------------------------|
| G-1826  | Idler Gear                      | P-1542 | Ball Bearing (2)               |
| *G-1827 | Idler Gear and Bracket          | P-1562 | Idler Gear Shaft               |
| P-1471  | Idler Gear Shaft Fastening Nut  | P-1563 | Idler Gear Bracket             |
| P-1507  | Ball Bearing Retaining Ring (2) | P-1566 | Bracket Mounting Screw (Short) |
| P-1526  | Bracket Mounting Screw (Long)   | P-2480 | Ball Bearing Spacer            |
| P-1539  | Projector Main Drive Gear       | P-3062 | Loading Spring                 |

\* Includes G-1826, P-1471, P-1507, P-1542, P-1562, P-1563, P-2480, P-3062.

Allen Wrench No.

P-2712

Required for

P-1526

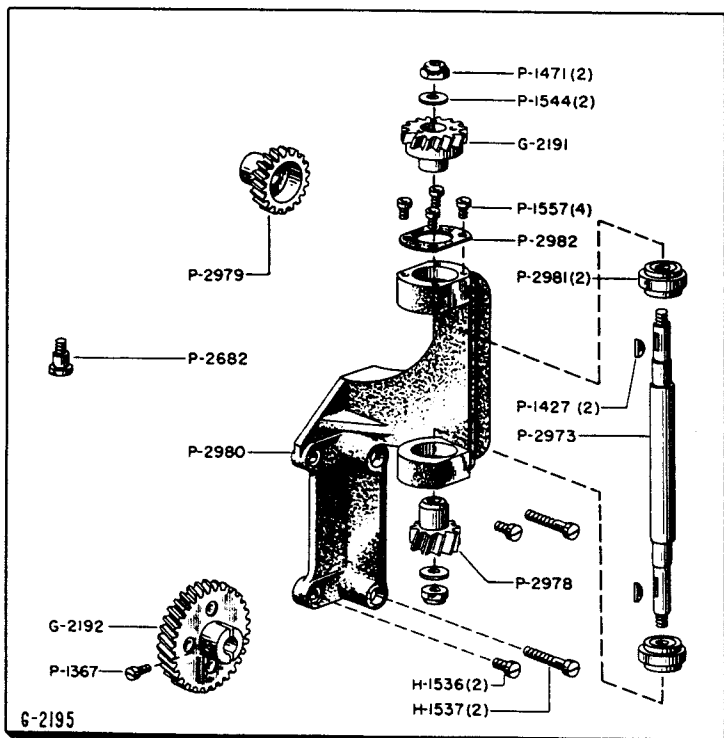

### G-2195 DRIVE KIT (Century R2, R6 and Westrex Master Soundheads)

- |        |   |
|--------|---|
| G-2191 | Upper Drive Gear                              |
| G-2192 | Horizontal Main Drive Gear                    |
| H-1536 | Vertical Bracket Fastening Screw (2)          |
| H-1537 | Vertical Bracket Fastening Screw (2)          |
| P-1367 | Horizontal Main Drive Gear<br>Fastening Screw |
| P-1427 | Lower—Upper Drive Gear Key (2)                |
| P-1471 | Vertical Drive Shaft Fastening Nut (2)        |
| P-1544 | Ball Bearing—Gear Retainer<br>Washer (2)      |
| P-1557 | Retainer Plate Fastening Screw (4)            |
| P-2682 | Cover Hinge Fastening Screw                   |
| P-2973 | Vertical Drive Shaft                          |
| P-2978 | Lower Drive Gear                              |
| P-2979 | Projector Main Drive Gear                     |
| P-2980 | Vertical Drive Bracket                        |
| P-2981 | Ball Bearing (2)                              |
| P-2982 | Ball Bearing Retainer Plate                   |

Allen Wrench No.

P-1395

Required for

P-1557

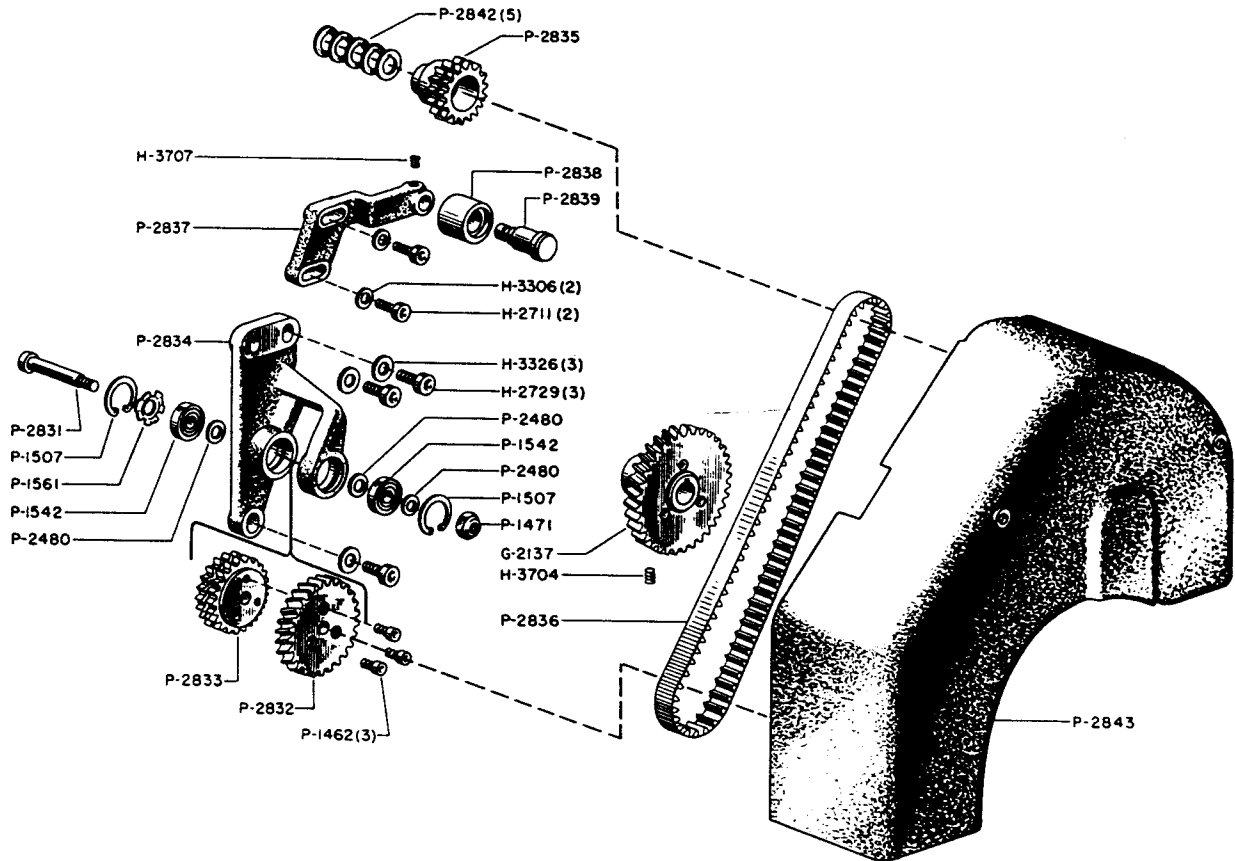

**G-2069 DRIVE KIT**  
**(Motiograph SH-7500, W.E. TA-7500 Soundheads)**

G-2137	Soundhead Main Drive Gear	P-1471	Shaft Fastening Nut
H-2711	Idler Roller Bracket Fastening Screw (2)	P-1507	Ball Bearing Retaining Ring (2)
H-2729	Intermediate Gear Bracket Fastening Screw (3)	P-1542	Ball Bearing (2)
H-3306	Idler Roller Bracket Washer (2)	P-1561	Loading Spring
H-3326	Intermediate Gear Bracket Washer (3)	P-2480	Intermediate Gear Washer (3)
H-3704	Projector Main Drive Sprocket Set Screw	P-2831	Intermediate Gear Shaft
H-3707	Idler Roller Set Screw	P-2832	Intermediate Gear
		P-2833	Drive Chain Sprocket
P-1462	Intermediate Gear-Chain Sprocket Fastening Screw (3)	P-2834	Intermediate Gear Bracket
		P-2835	Projector Main Drive Sprocket
		P-2836	Drive Chain
		P-2837	Idler Roller Bracket
		P-2838	Idler Roller
		P-2839	Idler Roller Stud
		P-2842	Main Drive Sprocket Shim (Set of 5)
		P-2843	Gear Side Cover

Allen Wrench No.

P-1395  
P-2712  
P-2794

Required for

H-3704, P-1462  
H-2711, H-2729  
H-3707

## G-2129 DRIVE KIT (W.E. TA-7400 Reproducer Set)

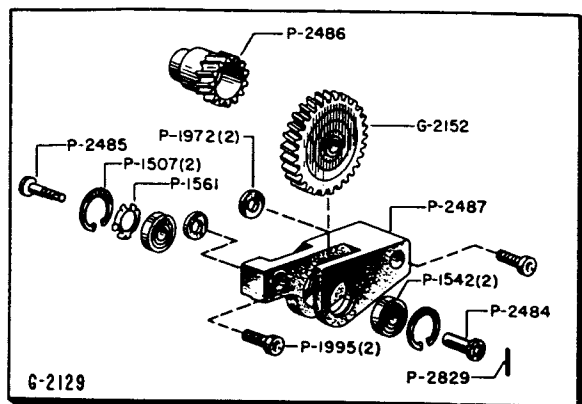

\* Only used when G-2152 and Soundhead Gear are not in line.

G-2152 Idler Gear

- P-1507 Ball Bearing Retaining Ring (2)
- P-1542 Ball Bearing (2)
- P-1561 Loading Spring
- \*P-1972 Spacing Washer (2)
- P-1995 Mounting Bracket Fastening Screw (2)
- P-2484 Idler Gear Shaft
- P-2485 Idler Gear Fastening Screw
- P-2486 Projector Main Drive Gear
- P-2487 Idler Gear Mounting Bracket
- P-2829 Fastening Screw Retaining Pin

Allen Wrench No.	Required for
P-2712	P-1995

## G-2130 DRIVE KIT (RCA PS-24, MI-1023 to MI-1032 Soundheads)

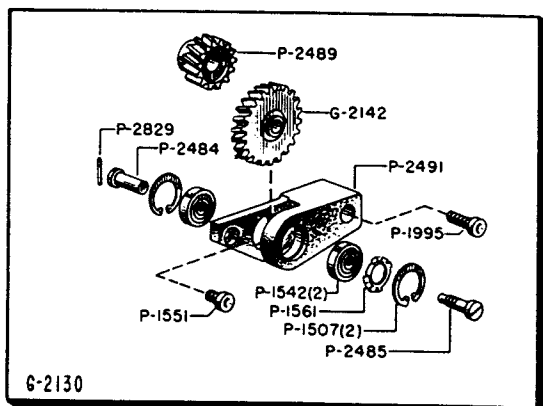

G-2142 Idler Gear

- P-1507 Ball Bearing Retaining Ring (2)
- P-1542 Ball Bearing (2)
- P-1551 Mounting Bracket Fastening Screw (Short)
- P-1561 Loading Spring
- P-1995 Mounting Bracket Fastening Screw (Long)
- P-2484 Idler Gear Shaft
- P-2485 Idler Gear Fastening Screw
- P-2489 Projector Main Drive Gear
- P-2491 Idler Gear Mounting Bracket
- P-2829 Fastening Screw Retaining Pin

Allen Wrench No.	Required for
P-2712	P-1551, P-1995

## G-2068 DRIVE KIT (RCA MI-1040 to MI-1077, MI-9030 to MI-9070 Soundheads)

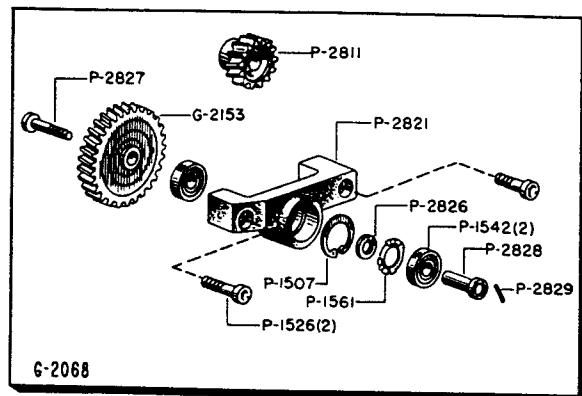

G-2153 Idler Gear

- P-1507 Ball Bearing Retaining Ring
- P-1526 Bracket Mounting Screw (2)
- P-1542 Ball Bearing (2)
- P-1561 Loading Spring
- P-2811 Projector Main Drive Gear
- P-2821 Idler Gear Bracket
- P-2826 Ball Bearing Spacer
- P-2827 Shaft Fastening Screw
- P-2828 Idler Gear Shaft
- P-2829 Shaft Fastening Screw Retaining Pin

Allen Wrench No.	Required for
P-2712	P-1526

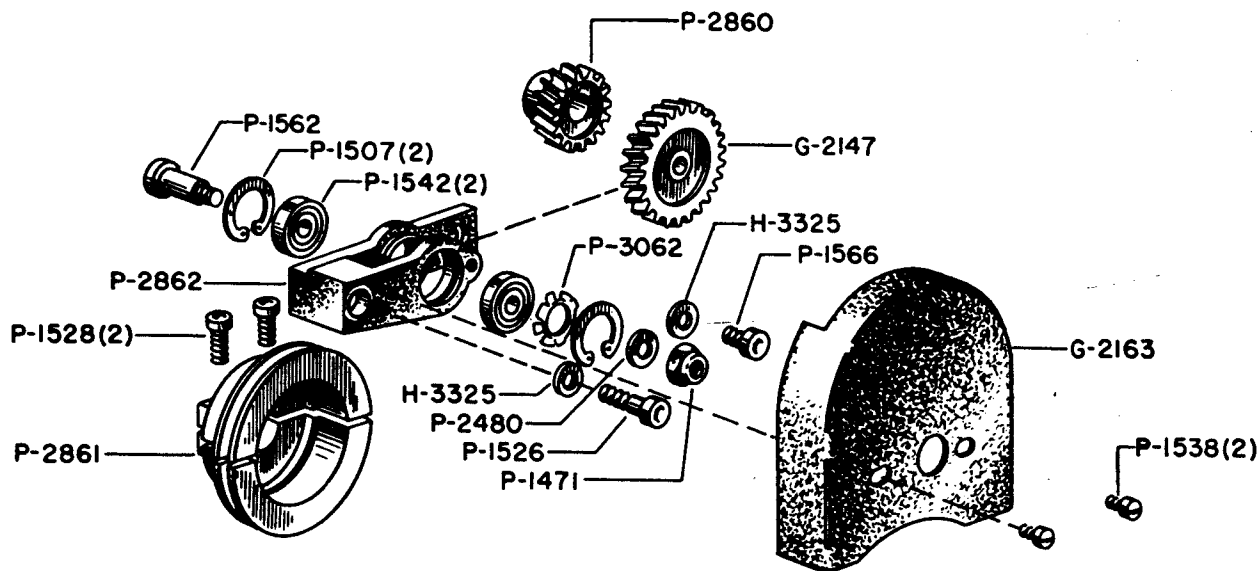

### G-2149 DRIVE KIT (W.E. 206-208 Reproducer Set)

G-2147 Idler Gear  
 G-2163 Gear Side Cover

H-3325 Bracket Washer (2)

P-1471 Idler Gear Shaft Fastening Nut  
 P-1507 Ball Bearing Retainer Ring (2)  
 P-1526 Bracket Fastening Screw (Long)  
 P-1528 Takeup Pulley Fastening Screw (2)  
 P-1538 Cover Fastening Screw (2)  
 P-1542 Ball Bearing (2)  
 P-1562 Idler Gear Shaft  
 P-1566 Bracket Fastening Screw (Short)  
 P-2480 Ball Bearing Retaining Washer  
 P-2860 Projector Main Drive Gear  
 P-2861 Takeup Pulley  
 P-2862 Idler Gear Bracket  
 P-3062 Loading Spring

Allen Wrench No.

P-2711  
 P-2712

Required for

P-1528  
 P-1526, P-1566



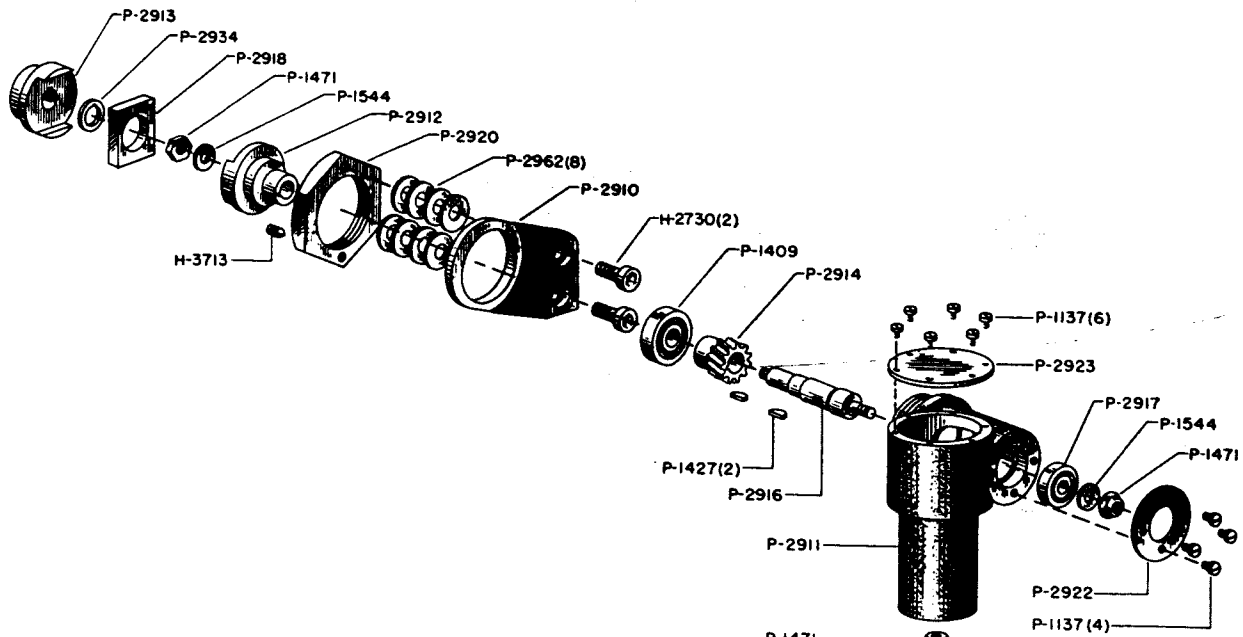

## G-2180 DRIVE KIT (W.E. Universal Base)

H-2730 Mounting Bracket Fastening Screw (2)  
 H-3713 Gear Box Fastening Nut Set Screw

P-1137 Retainer Plate-Cover Fastening Screw (14)  
 P-1409 Ball Bearing (3)  
 P-1427 Gear-Fork Key (3)  
 P-1471 Vertical—Horizontal Shaft Fastening Nut (3)  
 P-1544 Ball Bearing Retainer Washer (3)  
 P-2910 Gear Box Mounting Bracket  
 P-2911 Gear Box  
 P-2912 Flexible Coupling Drive Fork  
 P-2913 Flexible Coupling Driven Fork  
 P-2914 Horizontal Driven Gear  
 P-2915 Vertical Drive Gear  
 P-2916 Horizontal Driven Shaft  
 P-2917 Horizontal Shaft Ball Bearing  
 P-2918 Flexible Coupling Drive Block  
 P-2919 Vertical Shaft  
 P-2920 Gear Box Fastening Nut  
 P-2921 Ball Bearing Retainer Plate  
 P-2922 Bearing Retainer Flange  
 P-2923 Gear Box Cover  
 P-2924 Vertical Shaft Bearing Spacer  
 P-2934 Flexible Coupling Spacing Washer  
 P-2962 Mounting Bracket Shim Washer (Set of 8)

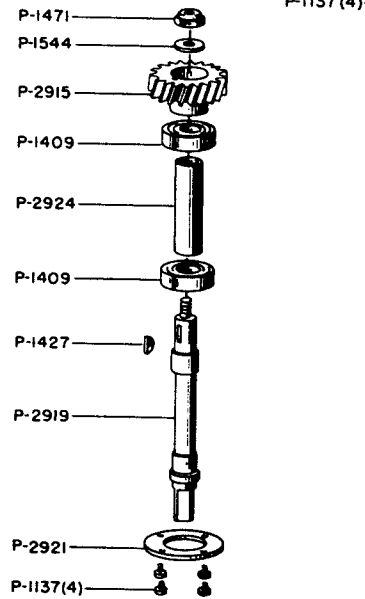

Allen Wrench No.

P-2794

Required for

H-3713

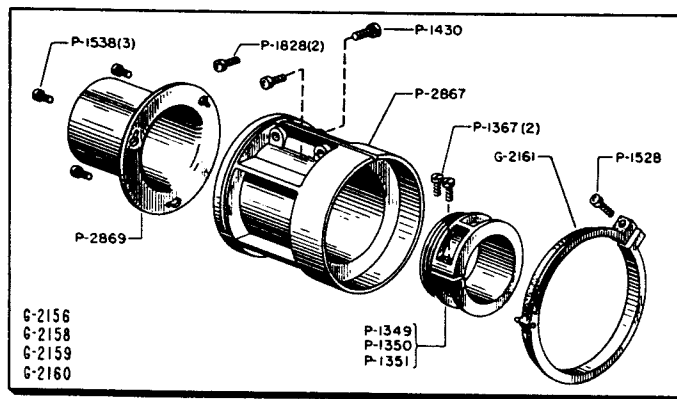
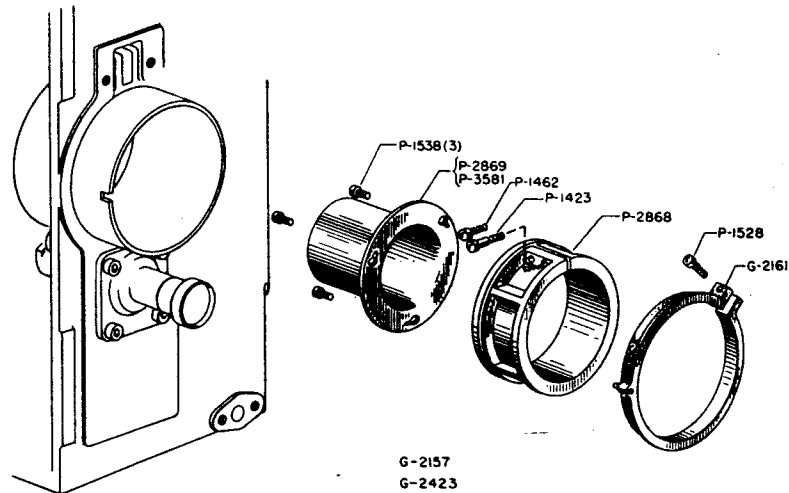

- G-2156 LENS ADAPTER KIT (2 25/32" Diameter Lens)  
 G-2157 LENS ADAPTER KIT (4" Diameter Lens—F:2.0)  
 G-2158 LENS ADAPTER KIT (2 1/32" Diameter Lens)  
 G-2159 LENS ADAPTER KIT (2.118" Diameter Lens)  
 G-2160 LENS ADAPTER KIT (2 1/8" Diameter Lens)  
 G-2423 LENS ADAPTER KIT (4" Diameter Lens—F:1.8)

G-2161 Lens Stop Ring (includes P-1528)

P-1462 Lens Adapter Expansion Screw (G-2157, G-2423)

P-1349 Reducing Adapter (G-2158)  
 P-1350 Reducing Adapter (G-2159)  
 P-1351 Reducing Adapter (G-2160)  
 P-1367 Reducing Adapter Clamping Screw (G-2158, G-2159, G-2160) (2)

P-1528 Lens Stop Ring Clamping Screw

P-1538 Light Shield Fastening Screw (3)

P-1828 Lens Adapter Clamping Screw (G-2156, G-2158, G-2159, G-2160) (2)

P-1423 Lens Adapter Clamping Screw (G-2157, G-2423)

P-2867 Lens Adapter (G-2156, G-2158, G-2159, G-2160)

P-2868 Lens Adapter (G-2157, G-2423)

P-1430 Lens Adapter Expansion Screw (G-2156, G-2158, G-2159, G-2160)

P-2869 Light Shield (G-2156 thru G-2160)

P-3581 Light Shield (G-2423)

Allen Wrench No.

P-1395  
 P-2711

Required for

P-1423, P-1462  
 P-1430, P-1528, P-1828

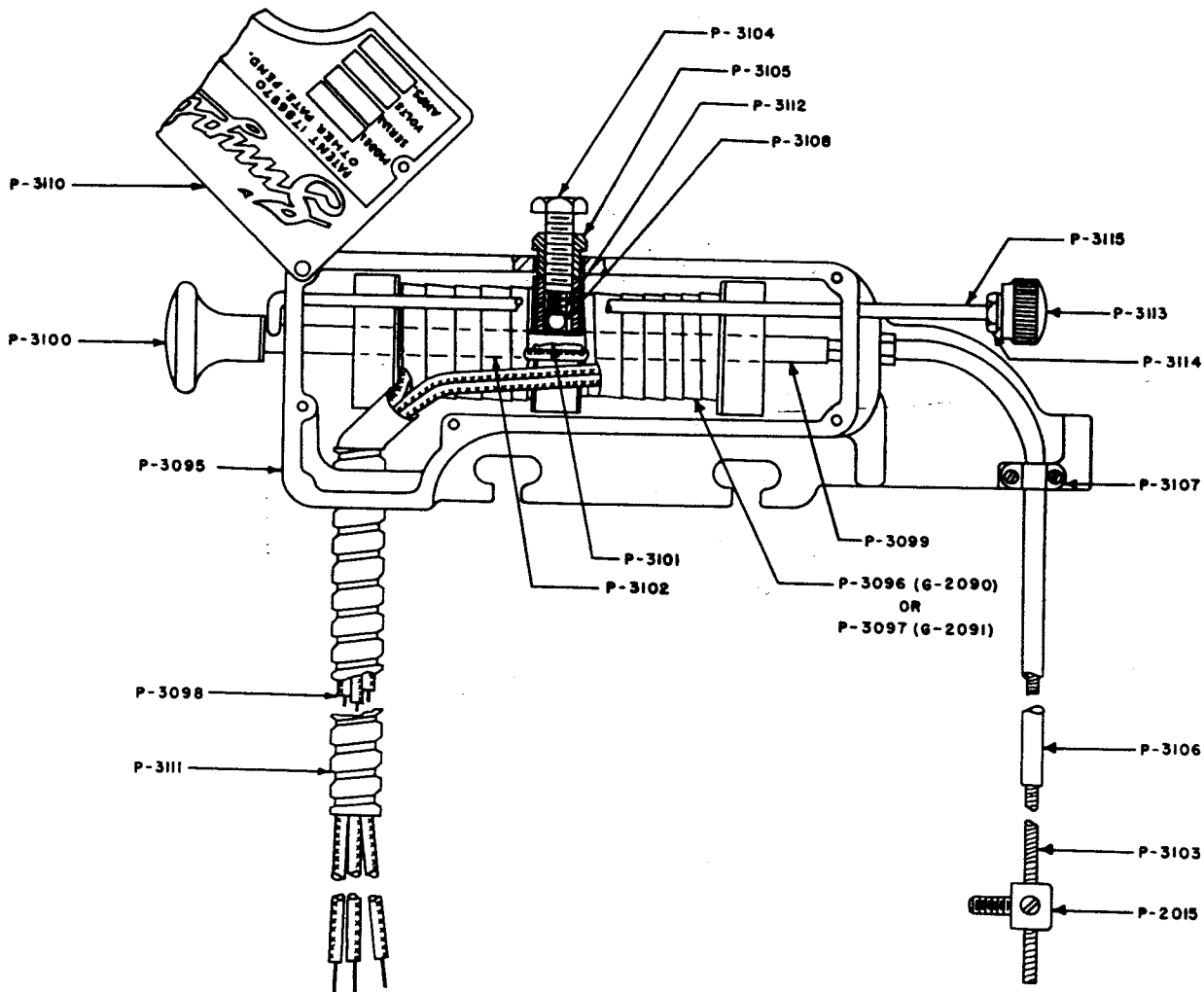

**G-2090 PICTURE CHANGEOVER (115 Volts AC)**  
**G-2091 PICTURE CHANGEOVER (115 Volts DC)**

- P-2015 Dowser Pivot Clamp and Set Screws
- P-3095 Housing
- P-3096 Coil—115 Volts AC
- P-3097 Coil—115 Volts DC
- P-3098 Three-Wire Cable (6 feet standard)
- P-3099 Armature, Flexible Shaft and Non-Operating Side Knob Complete
- P-3100 Non-Operating Side Knob
- P-3101 Steel Armature
- P-3102 Brass Armature Section
- P-3103 Flexible Shaft and Connector
- P-3104 Speed Adjusting Screw
- P-3105 Speed Adjusting Screw Locknut
- P-3106 Flexible Shaft Tube
- P-3107 Flexible Shaft Tube Clamp
- P-3108 Speed Adjusting Screw Ball
- P-3110 Cover and Nameplate
- P-3111 Flexible Conduit
- P-3112 Speed Adjusting Screw Compression Spring
- P-3113 Operating Side Knob
- P-3114 Operating Side Knob Locknut and Washer
- P-3115 Operating Side Rod

# SECTION III

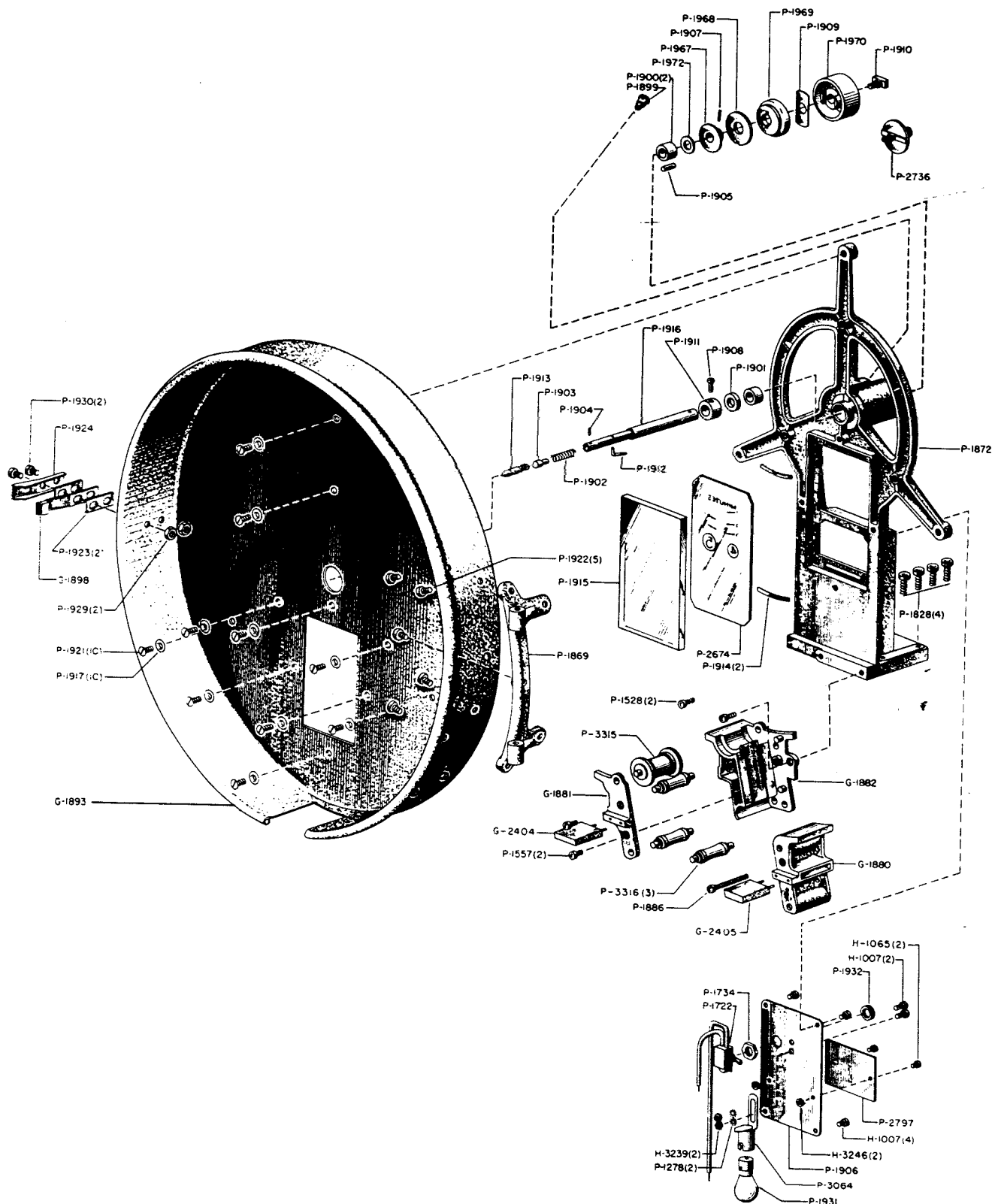

X-L UPPER MAGAZINE AND ROLLER HOLDER ASSEMBLY

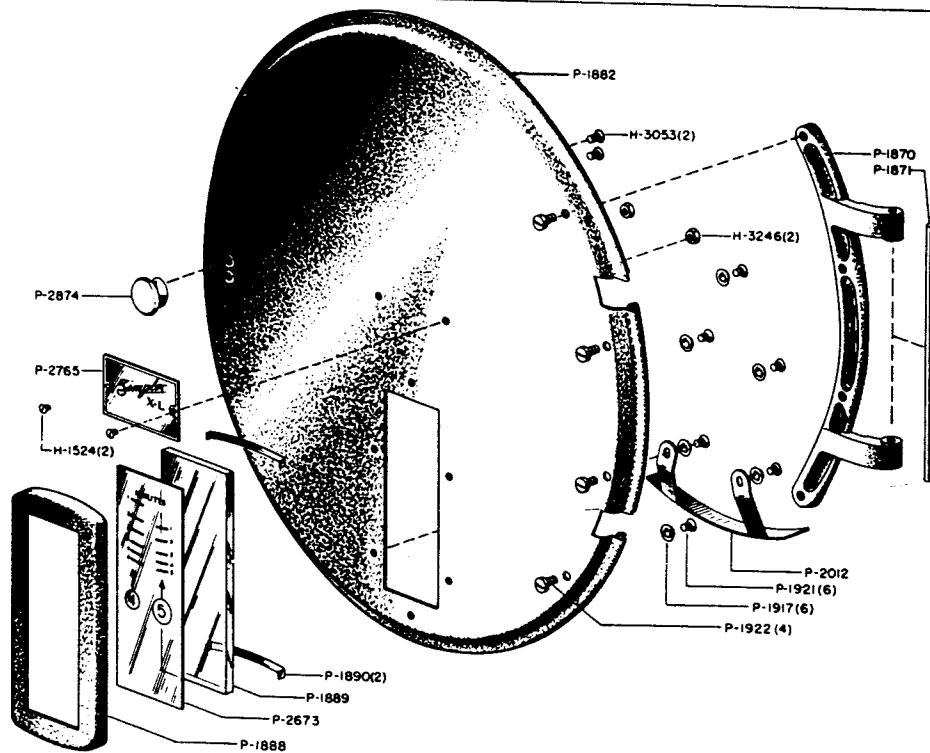

### X-L UPPER MAGAZINE AND ROLLER HOLDER ASSEMBLY PARTS

- |           |  |           |  |
|-----------|--|-----------|--|
| G-1880    | Roller Holder Right Cover                    | P-1905    | Friction Disc Stop Pin   |
| G-1881    | Roller Holder Left Cover                     | P-1906    | Pilot Light Cover Plate  |
| G-1882    | Roller Holder Case                           | ***P-1907 | Disc Flange Pin  |
| G-1893    | Magazine Case                                | P-1908    | Collar Fastening Screw   |
| G-1895    | Reel Shaft, Lock, Friction Flange and Disc   | P-1909    | Friction Spring  |
| G-1898    | Magazine Cover Latch                         | P-1910    | Tension Adjusting Knob Lock Screw                                  |
| *G-2404   | Roller Holder, Right Cover Extension         | P-1911    | Reel Shaft Collar  |
| **G-2405  | Roller Holder, Left Cover Extension          | P-1912    | Collar Pin   |
| H-1007    | Pilot Light Socket-Cover Fastening Screw (6) | ***P-1913 | Reel Lock  |
| H-1065    | Nameplate Fastening Screw (2)                | P-1914    | Magazine Case Window Retaining Spring (2)                          |
| H-1524    | Nameplate Fastening Screw (2)                | P-1915    | Magazine Case Window   |
| H-3053    | Cover Knob Fastening Screw (2)               | ***P-1916 | Reel Shaft (not sold separately—Order G-1895)                      |
| H-3239    | Pilot Light Socket Fastening Screw Nut (2)   | P-1917    | Window Frame—Support Bracket Cup Washer (16)                       |
| H-3246    | Nameplate Fastening Screw Nut (4)            | P-1921    | Window Frame—Support Bracket Fastening Screw (16)                  |
| P-1278    | Pilot Light Socket Lockwasher (2)            | P-1922    | Hinge Fastening Screw (9)  |
| P-1528    | Roller Holder Fastening Screw (2)            | P-1923    | Cover Latch Spring Spacer (2)                                      |
| P-1557    | Roller Holder Left Cover Fastening Screw (2) | P-1924    | Cover Latch Spring Guard   |
| P-1722    | Pilot Light Switch                           | P-1929    | Cover Latch Fastening Nut (2)                                      |
| P-1734    | Pilot Light Switch Lock Nut                  | P-1930    | Cover Latch Fastening Screw (2)                                    |
| P-1828    | Magazine Fastening Screw (4)                 | P-1931    | Pilot Light, 6-8 Volts   |
| P-1869    | Magazine Case Hinge                          | P-1932    | Pilot Light Switch Knurled Fastening Nut                           |
| P-1870    | Magazine Cover Hinge                         | ***P-1967 | Reel Shaft Friction Disc Flange (not sold separately—Order G-1895) |
| P-1871    | Hinge Pin                                    | ***P-1968 | Reel Shaft Friction Disc   |
| P-1872    | Support Bracket                              | P-1969    | Friction Spring Flange   |
| P-1882    | Magazine Cover                               | P-1970    | Tension Adjusting Knob   |
| P-1886    | Roller Holder Right Cover Fastening Screw    | P-1972    | Spacing Washer   |
| P-1888    | Cover Window Frame                           | P-2012    | Film Slot Shield   |
| P-1889    | Cover Window                                 | P-2673    | Magazine Cover Cue Scale   |
| P-1890    | Cover Window Retaining Spring (2)            | P-2674    | Magazine Case Cue Scale  |
| P-1899    | Oil Cup                                      | P-2736    | Reel End Alarm Screw and Flange                                    |
| P-1900    | Support Bracket Bearing (2)                  | P-2765    | Simplex X-L Nameplate  |
| P-1901    | Reel Shaft Spacer                            | P-2797    | National Theatre Supply Nameplate                                  |
| ***P-1902 | Reel Shaft Spring                            | P-2874    | Magazine Cover Knob  |
| ***P-1903 | Reel Shaft Plunger                           | P-3064    | Pilot Light Socket   |
| ***P-1904 | Reel Lock Pin                                | P-3315    | Large Roller   |
|           |  | P-3316    | Small Roller (3)   |

\* Part of G-1881—(not sold separately)  
 \*\* Part of G-1880—(not sold separately)  
 \*\*\* Part of G-1895

#### Allen Wrench No.

P-1395  
P-2711

#### Required for

P-1557, P-1886  
P-1528, P-1828

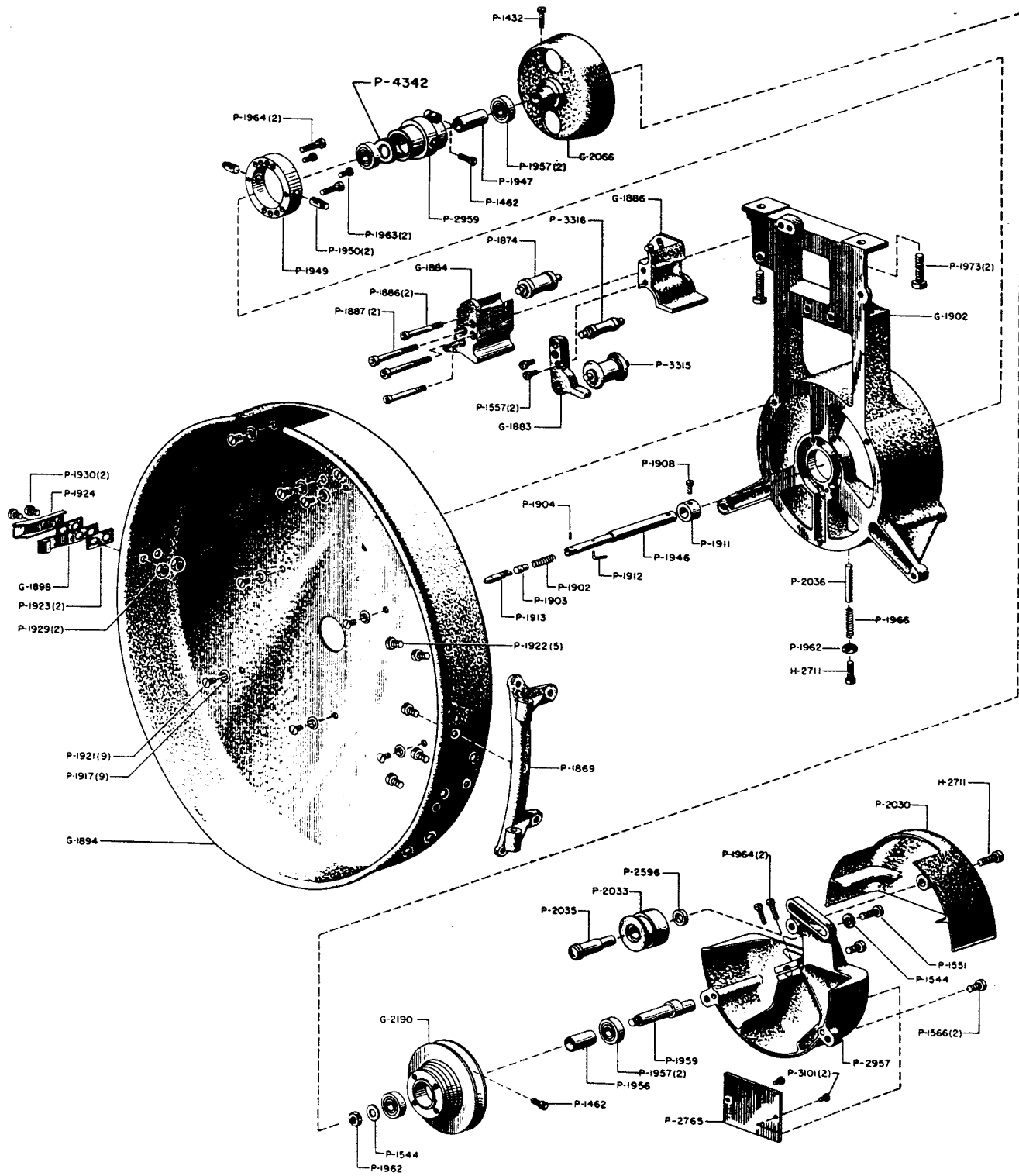

X-L LOWER MAGAZINE AND ROLLER HOLDER

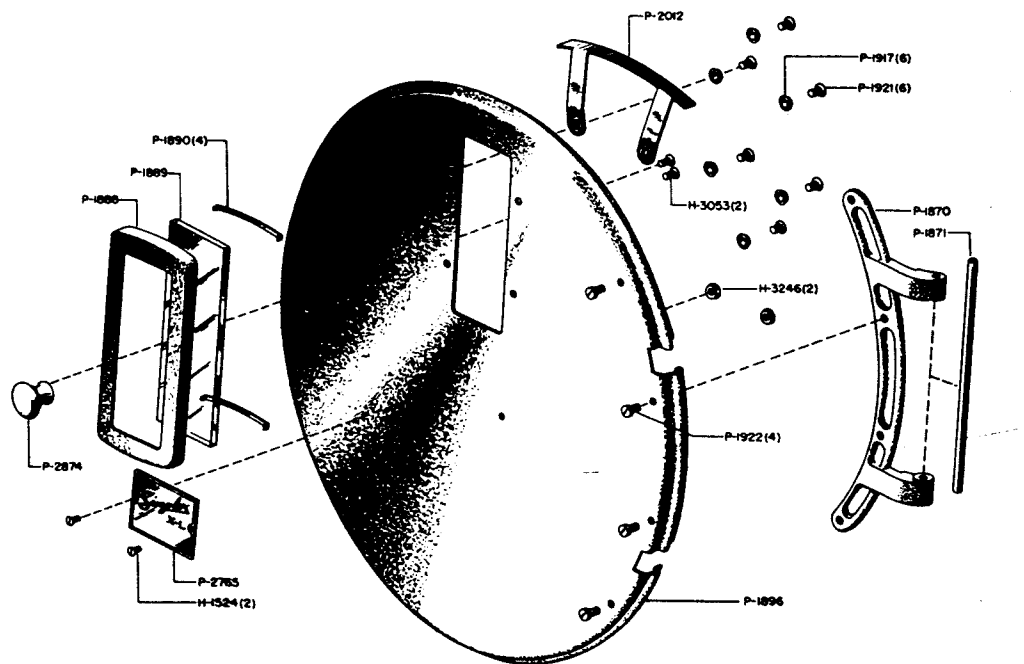

### X-L LOWER MAGAZINE AND ROLLER HOLDER

- |         |                                     |         |  |
|---------|-------------------------------------|---------|--|
| G-1883  | Roller Holder Right Cover           | P-1911  | Reel Shaft Collar                          |
| G-1884  | Roller Holder Left Cover            | P-1912  | Collar Pin                                 |
| G-1886  | Roller Holder Case                  | P-1913  | Reel Lock                                  |
| G-1894  | Magazine Case                       | P-1917  | Window Frame—Bracket Cup                   |
| G-1898  | Cover Latch                         |         | Washer (15)                                |
| G-1902  | Support Bracket and Pins            | P-1921  | Window Frame—Bracket Fastening             |
| G-2066  | Reel Shaft Drive Drum               |         | Screw (15)                                 |
|         |                                     | P-1922  | Hinge Fastening Screw (9)                  |
| G-2190  | Takeup Pulley and Discs             | P-1923  | Latch Spacer (2)                           |
|         |                                     | P-1924  | Latch Protector                            |
| H-1524  | Nameplate Fastening Screw (2)       | P-1929  | Latch Fastening Nut (2)                    |
| H-2711  | Pressure Adjusting—Upper Cover      | P-1930  | Latch Fastening Screw (2)                  |
|         | Fastening Screw (2)                 | P-1946  | Reel Shaft                                 |
| H-3053  | Knob Fastening Screw (2)            | P-1947  | Bearing Spacer                             |
| H-3101  | Nameplate Fastening Screw (2)       | P-1949  | Bearing Housing Flange                     |
| H-3246  | Nameplate Fastening Nut (2)         | P-1950  | Bearing Housing Flange Pin (2)             |
|         |                                     | P-1956  | Takeup Pulley Ball Bearing Spacer          |
| P-1432  | Drive Drum Fastening Screw          | P-1957  | Ball Bearing (4)                           |
| P-1462  | Takeup Pulley—Bearing Housing       | P-1959  | Takeup Pulley Eccentric Stud               |
|         | Clamping Screw (2)                  | P-1962  | Takeup Pulley Eccentric Stud—              |
| P-1544  | Takeup Pulley Eccentric Stud        |         | Pressure Adjusting Screw Nut (2)           |
|         | Washer                              | P-1963  | Bearing Flange Pin Retaining               |
| *P-1544 | Idler Roller Washer ("V" Belt Only) |         | Screw (2)                                  |
| *P-1551 | Idler Roller Stud Fastening Screw   | P-1964  | Bearing Flange—Eccentric Stud              |
|         | ("V" Belt Only)                     |         | Fastening Screw (4)                        |
| P-1557  | Roller Holder Right Cover           | P-1966  | Pressure Adjusting Spring                  |
|         | Fastening Screw (2)                 | P-1973  | Magazine Fastening Screw (2)               |
| P-1566  | Lower Cover Fastening Screw (2)     | P-2012  | Film Slot Shield                           |
| P-1869  | Magazine Case Hinge                 | P-2030  | Takeup Upper Cover                         |
| P-1870  | Magazine Cover Hinge                | *P-2033 | Idler Roller ("V" Belt Only)               |
| P-1871  | Hinge Pin                           | P-2034  | Round Takeup Belt—44"                      |
| P-1874  | Large Upper Roller                  | *P-2035 | Idler Roller Stud ("V" Belt Only)          |
| P-1886  | Roller Holder Left Cover            | P-2036  | Pressure Adjusting Plunger                 |
|         | Fastening Screw (2)                 | *P-2596 | Idler Roller Spacer ("V" Belt Only)        |
| P-1887  | Roller Holder Fastening Screw (2)   | P-2599  | Belt Hook                                  |
| P-1888  | Window Frame                        |         |  |
| P-1889  | Cover Window                        | P-2765  | Simplex X-L Nameplate (2)                  |
| P-1890  | Cover Window Retaining Spring (2)   | P-2874  | Cover Knob                                 |
| P-1896  | Magazine Cover                      | P-2957  | Takeup Lower Cover                         |
| P-1502  | Reel Lock Spring                    | P-2959  | Bearing Housing                            |
| P-1903  | Reel Lock Plunger                   | *P-2966 | "V" Takeup Belt—42" (Four Star Soundheads) |
| P-1904  | Lock Pin                            | *P-2967 | "V" Takeup Belt—44" (X-L Soundheads)       |
| P-1908  | Collar Fastening Screw              | P-3315  | Large Lower Roller                         |
|         |                                     | P-3316  | Small Roller                               |

\* These parts are furnished with the magazine only when "V" belts are specified and otherwise must be ordered separately.

#### Allen Wrench No.

P-1395  
P-2711  
P-2712  
P-2734  
P-2908

#### Required for

P-1432, P-1462, P-1557, P-1886, P-1964  
P-1887  
H-2711, P-1551, P-1566  
P-1963  
P-1973



# SECTION IV

NUMERICAL LIST OF PARTS

Part No.	Page No.	Part No.	Page No.	Part No.	Page No.
G-1800	1-28	G-2090	1-18, 2-6	G-2514	1-2
G-1801	1-28	G-2091	1-18, 2-6	G-2515	1-2
G-1802	1-28	G-2109	1-2	G-2622	1-4
G-1803	1-28	G-2110	1-2	G-4125	1-16
G-1804	1-26	G-2111	1-2	G-4127	1-16
G-1806	1-17	G-2115	1-18	G-4128	1-16
G-1807	1-26	G-2129	2-2	G-4129	1-16
G-1809	1-17	G-2130	2-2	G-4130	1-16
G-1812	1-17	G-2137	2-1	G-4131	1-16
G-1815	1-24	G-2142	2-2	G-4148	1-16
G-1819	1-22	G-2143	1-18	G-4237	1-25
G-1820	1-22	G-2144	1-15, 1-16	G-4289	1-24
G-1822	1-22	G-2147	2-3	G-4310	1-5, 1-20
G-1825	1-18	G-2149	2-3	G-4311	1-15
G-1826	2-0	G-2152	2-2	G-4318	1-4
G-1827	2-0	G-2153	2-2	G-4319	1-4
G-1828	1-15, 1-16	G-2156	2-5		
G-1830	1-15	G-2157	2-5	H-1005	1-12
G-1836	1-15	G-2158	2-5	H-1007	3-0
G-1837	1-15	G-2159	2-5	H-1020	1-20
G-1843	1-6	G-2160	2-5	H-1065	3-0
G-1850	1-6	G-2161	2-5	H-1505	1-11
G-1852	1-2	G-2163	2-3	H-1512	1-0
G-1854	1-0	G-2173	1-18	H-1524	3-0, 3-1,
G-1855	1-18	G-2178	1-15		3-3
G-1859	1-10	G-2180	2-4	H-1536	2-0
G-1861	1-20	G-2190	3-2	H-1537	2-0
G-1863	1-6	G-2191	2-0	H-1544	1-12
G-1865	1-8	G-2192	2-0	H-2010	1-20
G-1867	1-8	G-2195	2-0	H-2504	1-24
G-1870	1-8	G-2302	1-2	H-2507	1-20
G-1876	1-0	G-2303	1-2	H-2508	1-8
G-1880	3-0	G-2304	1-2	H-2509	1-8
G-1881	3-0	G-2305	1-2	H-2517	1-4
G-1882	3-0	G-2306	1-2	H-2523	1-24
G-1883	3-2	G-2307	1-2	H-2709	1-0, 1-6
G-1884	3-2	G-2308	1-2	H-2711	1-18, 2-1,
G-1886	3-2	G-2309	1-2		3-2
G-1891	1-21	G-2330	1-17	H-2729	2-1
G-1893	3-0	G-2332	1-17, 1-26	H-2730	2-4
G-1894	3-2	G-2335	1-18	H-2732	1-20
G-1895	3-0	G-2402	1-2	H-3052	1-0
G-1898	3-0, 3-2	G-2403	1-2	H-3053	3-1, 3-3
G-1902	3-2	G-2404	3-0	H-3101	1-18, 3-2
G-1905	1-6	G-2405	3-0	H-3218	1-12
G-1909	1-26	G-2412	1-2	H-3239	1-20, 3-0
G-1910	1-12	G-2414	1-2	H-3246	3-0, 3-1,
G-2046	1-22	G-2423	2-5		3-3
G-2066	3-2	G-2436	1-2	H-3252	1-26
G-2068	2-2	G-2468	1-2	H-3253	1-0, 1-12,
G-2069	2-1	G-2475	1-2		1-20
G-2086	2-0	G-2513	1-2	H-3304	1-18

Part No.	Page No.	Part No.	Page No.	Part No.	Page No.
H-3306	2-1	P-11424	1-28	P-11471	1-14,2-0,
H-3312	1-14,1-18	P-11425	1-28		2-1,2-3,
H-3325	2-3	P-11426	1-28		2-4
H-3326	2-1	P-11427	1-14,1-28,	P-11472	1-24
H-3328	1-12		2-0,2-4	P-11473	1-24
H-3352	1-24	P-11428	1-17,1-18,	P-11474	1-24
H-3445	1-20		1-26	P-11475	1-24
H-3448	1-20	P-11429	1-17,1-26	P-11476	1-24
H-3524	1-20	P-11430	1-17,1-26,	P-11477	1-24
H-3704	2-1		2-5	P-11478	1-24
H-3707	2-1	P-11431	1-17,1-26	P-11479	1-24
H-3713	2-4	P-11432	1-10,1-15,	P-11480	1-24
H-3719	1-26		1-17,1-17,	P-11481	1-24
H-3922	1-5		1-20,1-24,	P-11482	1-24
H-3923	1-5		1-26,3-2	P-11483	1-24
		P-11433	1-18,1-22	P-11484	1-24
P-1137	2-4	P-11435	1-2	P-11485	1-24
P-1151	1-26	P-11437	1-26	P-11486	1-24
P-1190	1-15,1-16	P-11438	1-26	P-11487	1-24
P-1200	1-24,1-28	P-11440	1-26	P-11488	1-24
P-1266	1-26	P-11441	1-17,1-26	P-11489	1-24
P-1267	1-0	P-11442	1-17,1-26	P-11490	1-24
P-1277	1-12	P-11443	1-17,1-26	P-11491	1-24
P-1278	1-12,1-20,		1-28	P-11492	1-24
	3-0	P-11445	1-6,1-17,	P-11494	1-24
P-1281	1-0,1-20		1-24,1-26	P-11495	1-24
P-1349	2-5	P-11447	1-17,1-26	P-11496	1-24
P-1350	2-5	P-11448	1-26	P-11497	1-24
P-1351	2-5	P-11450	1-17	P-11498	1-24
P-1367	2-0,2-5	P-11451	1-17,1-26	P-11499	1-24
P-1395	1-7,1-9,	P-11452	1-17,1-26	P-1500	1-24
	1-10,1-13,	P-11454	1-17,1-19,	P-1501	1-24
	1-14,1-15,		1-26	P-1502	1-24
	1-16,1-17,	P-11455	1-26	P-1504	1-24
	1-18,1-19,	P-11456	1-17	P-1505	1-24
	1-21,1-25,	P-11457	1-17	P-1506	1-24
	1-26,1-27,	P-11458	1-17,1-26	P-1507	1-24,2-0,
	1-28	P-11459	1-17		2-1,2-2,
P-11406	1-28	P-11461	1-17		2-3
P-11408	1-28	P-11462	1-8,1-14,	P-1510	1-24
P-11409	1-14,1-28,		1-17,1-18,	P-1511	1-16,1-24,
	2-4		1-20,1-26,	P-1514	1-22
P-11411	1-28		2-1,2-5,	P-1515	1-22
P-11412	1-28		3-2	P-1516	1-22
P-11413	1-28	P-11464	1-22,1-24	P-1517	1-22
P-11415	1-28	P-11465	1-20,1-22,	P-1518	1-22
P-11418	1-28		1-24	P-1522	1-22
P-11419	1-28	P-11466	1-20,1-22,	P-1523	1-18,1-22
P-11421	1-14		1-24	P-1525	1-22
P-11423	1-6,1-10,	P-11467	1-24	P-1526	2-0,2-2,2-3
	1-12,1-28,	P-11469	1-15,1-16,		1-10,1-12,
	2-5		1-24		1-18,1-20
		P-11470	1-24		1-22,1-24

Part No.	Page No.	Part No.	Page No.	Part No.	Page No.
P-1528	1-20, 2-3, 2-5, 3-0	P-1608	1-6	P-1729	1-0, 1-18
P-1529	1-18	P-1610	1-6	P-1730	1-18
P-1534	1-18	P-1611	1-6	P-1731	1-20
P-1535	1-18	P-1614	1-6	P-1732	1-0, 1-18, 1-20, 1-26
P-1536	1-14	P-1616	1-6	P-1733	1-0
P-1537	1-14	P-1617	1-6	P-1734	1-0, 3-1
P-1538	1-26, 2-3, 2-5	P-1618	1-6	F-1736	1-0
P-1539	1-14, 2-0	P-1620	1-6	P-1739	1-0
P-1540	1-14	P-1621	1-6	P-1743	1-10
P-1542	2-0, 2-1, 2-2, 2-3	P-1628	1-6	P-1744	1-10
P-1543	1-14	P-1629	1-6	P-1745	1-10
P-1544	2-0, 2-4, 3-2	P-1630	1-6	P-1746	1-10
P-1545	1-14	P-1631	1-6	P-1751	1-10
P-1546	1-14	P-1632	1-6	P-1752	1-10
P-1547	1-14	P-1633	1-6	P-1754	1-10
P-1548	1-14	P-1636	1-6	P-1755	1-10
P-1549	1-18	P-1637	1-6	P-1755	1-10
P-1550	1-18	P-1641	1-4	P-1750	1-10
P-1551	1-18, 2-2, 3-2	P-1642	1-6	P-1757	1-6
P-1552	1-18	P-1645	1-4	P-1758	1-11, 1-20, 1-26
P-1555	1-12, 1-18	P-1647	1-6	P-1762	1-20
P-1556	1-2	P-1648	1-6	P-1764	1-18
P-1557	1-6, 1-8, 1-10, 1-12, 1-17, 1-18, 1-20, 1-24, 1-26, 2-0, 3-0, 3-2	P-1652	1-17, 1-26	P-1767	1-20
P-1558	1-26	P-1653	1-17, 1-26	P-1773	1-2
P-1559	1-17	P-1660	1-6	P-1778	1-8, 1-15, 1-16, 1-20, 1-28
P-1560	1-24	P-1663	1-4	P-1779	1-24
P-1561	2-1, 2-2	P-1664	1-4	P-1789	1-8
P-1562	2-0, 2-3	P-1666	1-6	P-1791	1-8
P-1563	2-0	P-1667	1-8, 1-26	P-1792	1-8
P-1566	2-0, 2-3, 3-2	P-1676	1-4	P-1793	1-8
P-1569	1-10	P-1687	1-20	P-1794	1-8
P-1570	1-10	P-1698	1-2	P-1795	1-8
P-1571	1-10	P-1700	1-2	P-1796	1-8
P-1577	1-15, 1-16	P-1701	1-2	P-1797	1-8
P-1592	1-15, 1-16	P-1702	1-2	P-1798	1-8
P-1593	1-15, 1-16	P-1704	1-20	P-1799	1-8
P-1598	1-20	P-1705	1-20	P-1802	1-8
P-1599	1-15	P-1706	1-20	P-1803	1-8
P-1600	1-15, 1-16	P-1707	1-20	P-1810	1-8
P-1601	1-15, 1-16	P-1708	1-20	P-1812	1-Q
P-1602	1-15, 1-16	P-1713	1-0	P-1820	1-8
P-1607	1-6	P-1714	1-0	P-1821	1-8
		P-1715	1-0	P-1826	1-24
		P-1716	1-0	P-1827	1-6
		P-1718	1-0	P-1828	2-5, 3-0
		P-1719	1-0	P-1833	1-20
		P-1720	1-0	P-1834	1-11
		P-1722	3-0	P-1835	1-11
		P-1723	1-0	P-1836	1-11
		P-1724	1-0, 1-8		
		P-1725	1-18		
		P-1726	1-18		

Part No.	Page No.	Part No.	Page No.	Part No.	Page No.
P-1837	1-11	P-1921	3-0,3-1,	P-2432	1-20
P-1843	1-0		3-2,3-3	P-2480	2-0,2-1,2-3
P-1845	1-8	P-1922	3-0,3-1,	P-2481	1-18
P-1846	1-8		3-2,3-3	P-2484	2-2
P-1848	1-8	P-1923	3-0,3-2	P-2485	2-2
P-1849	1-8	P-1924	3-0,3-2	P-2486	2-2
P-1850	1-8	P-1929	3-0,3-2	P-2487	2-2
P-1851	1-8	P-1930	3-0,3-2	P-2489	2-2
P-1852	1-8	P-1931	3-0	P-2491	2-2
P-1853	1-8	P-1932	3-0	P-2519	1-20
P-1854	1-8	P-1935	1-20	P-2524	1-15,1-16
P-1855	1-20	P-1937	1-24	P-2553	1-18
P-1857	1-26	P-1938	1-15,1-16	P-2554	1-18
P-1860	1-26	P-1946	3-2	P-2577	1-18
P-1862	1-8	P-1947	3-2	P-2591	1-18
P-1869	3-0,3-2	P-1949	3-2	P-2596	3-2
P-1870	3-1,3-3	P-1950	3-2	P-2599	3-3
P-1871	3-1,3-3	P-1956	3-2	P-2625	1-20
P-1872	3-0	P-1957	3-2	P-2662	1-20
P-1874	3-2	P-1959	3-2	P-2665	1-10
P-1882	3-1	P-1962	3-2	P-2667	1-20
P-1885	1-20	P-1963	3-2	P-2668	1-20
P-1886	3-0,3-2	P-1964	3-2	P-2670	1-20
P-1887	3-2	P-1966	3-2	P-2672	1-18
P-1888	3-1,3-3	P-1967	3-0	P-2673	3-1
P-1889	3-1,3-3	P-1968	3-0	P-2674	3-0
P-1890	3-1,3-3	P-1969	3-0	P-2682	1-18,2-0
P-1891	1-20	P-1970	3-0	P-2709	1-10
P-1892	1-20	P-1971	1-15,1-16	P-2710	1-9,1-15,
P-1893	1-20	P-1972	2-2,3-0		1-16,1-22,
P-1894	1-20	P-1973	3-2		1-28
P-1896	3-3	P-1974	1-12	P-2711	1-1,1-7,
P-1899	3-0	P-1981	1-2		1-10,1-13,
P-1900	3-0	P-1983	1-12		1-17,1-18,
P-1901	3-0	P-1985	1-12		1-19,1-21,
P-1902	3-0,3-2	P-1990	1-12		1-23,1-25,
P-1903	3-0,3-2	P-1993	1-18		1-27,2-3,
P-1904	3-0,3-2	P-1995	1-18,1-28,	P-2712	2-5,3-1,3-3
P-1905	3-0		2-2		1-19,2-0,
P-1906	3-0	P-2001	1-24		2-1,2-2,
P-1907	3-0	P-2008	1-18		2-3,3-3
P-1908	3-0,3-2	P-2012	3-1,3-3	P-2725	1-3,1-25
P-1909	3-0	P-2013	1-24	P-2726	1-15,1-16
P-1910	3-0	P-2015	1-12,2-6	P-2736	3-0
P-1911	3-0,3-2	P-2016	1-17	P-2737	1-6
P-1912	3-0,3-2	P-2017	1-26	P-2765	3-0,3-2,3-3
P-1913	3-0,3-2	P-2018	1-26	P-2794	1-5,1-7,
P-1914	3-0	P-2030	3-2		1-17,1-27,
P-1915	3-0	P-2033	3-2		2-1,2-4,3-3
P-1916	3-0	P-2034	3-3	P-2797	3-0
P-1917	3-0,3-1,	P-2035	3-2	P-2811	2-2
	3-2,3-3	P-2036	3-2	P-2821	2-2

Part No.	Page No.	Part No.	Page No.	Part No.	Page No.
P-2826	2-2	P-2921	2-4	P-3110	2-6
P-2827	2-2	P-2922	2-4	P-3111	2-6
F-2828	2-2	P-2923	2-4	P-3112	2-6
F-2829	2-2	P-2924	2-4	P-3113	2-6
P-2831	2-1	P-2934	2-4	P-3114	2-6
F-2832	2-1	P-2935	1-22	P-3115	2-6
F-2833	2-1	P-2937	1-20	P-3134	1-26
F-2834	2-1	P-2940	1-10	P-3135	1-26
P-2835	2-1	P-2955	1-20	P-3291	1-4
F-2836	2-1	P-2957	3-2	P-3293	1-4
P-2837	2-1	P-2959	3-2	P-3296	1-4
P-2838	2-1	P-2960	1-6	F-3297	1-4
P-2839	2-1	P-2962	2-4	F-3298	1-4
F-2842	2-1	P-2964	1-24, 1-28	P-3304	1-18
P-2843	2-1	F-2966	3-3	F-3305	1-18
P-2848	1-26	P-2967	3-3	F-3306	1-18
P-2849	1-24	P-2968	1-24	F-3307	1-18
P-2853	1-17, 1-26	P-2969	1-24	F-3308	1-18
P-2860	2-3	P-2970	1-18	P-3309	1-18
P-2861	2-3	P-2973	2-0	P-3312	1-12
P-2862	2-3	P-2978	2-0	F-3313	1-26
P-2867	2-5	P-2979	2-0	P-3314	1-12
P-2868	2-5	P-2980	2-0	F-3315	3-0, 3-2
P-2869	2-5	P-2981	2-0	P-3316	3-0, 3-2
P-2874	1-0, 3-1, 3-3	P-2982	2-0	F-3544	1-18
P-2879	1-10	P-2984	1-28	P-3581	2-5
P-2883	1-20	P-2988	1-6	P-3625	1-12
P-2886	1-26	P-2996	1-12	P-3672	1-24
P-2888	1-11	P-2997	1-12	P-3922	1-16
F-2889	1-0	P-2998	1-12	P-3923	1-16
P-2890	1-12	P-3010	1-12	P-3927	1-16
F-2891	1-26	P-3045	1-8	P-3928	1-16
P-2894	1-11	P-3052	1-20	F-4068	1-4
P-2895	1-20	P-3055	1-17, 1-26	P-4091	1-4
P-2899	1-18	P-3062	2-0, 2-3	P-4117	1-16
P-2900	1-18, 1-20	P-3064	3-0	P-4146	1-26
P-2905	1-18	F-3066	1-17, 1-26	P-4290	1-4
F-2907	1-24	P-3085	1-17, 1-26	P-4295	1-5
P-2908	3-3	P-3095	2-6	P-4296	1-5
P-2909	1-24	P-3096	2-6	P-4297	1-20
P-2910	2-4	P-3097	2-6	P-4298	1-20
P-2911	2-4	P-3098	2-6	F-4299	1-20
P-2912	2-4	P-3099	2-6	P-4301	1-22
P-2913	2-4	P-3100	2-6	P-4303	1-22
P-2914	2-4	P-3101	2-6	P-4304	1-22
P-2915	2-4	P-3102	2-6	P-4316	1-22
P-2916	2-4	P-3103	2-6	P-4343	1-18
P-2917	2-4	P-3104	2-6		
P-2918	2-4	P-3105	2-6		
P-2919	2-4	P-3106	2-6		
P-2920	2-4	P-3107	2-6		
		P-3108	2-6		

NATIONAL THEATRE SUPPLY COMPANY

Branches

ALBANY 4, NEW YORK	962 Broadway
ATLANTA 3, GEORGIA	187 Walton Street, N.W.
BALTIMORE 2, MARYLAND	417 St. Paul Place
BOSTON 16, MASSACHUSETTS	37 Winchester Street
BUFFALO 2, NEW YORK	500 Pearl Street
CHARLOTTE 1, NORTH CAROLINA	304 S. Church Street
CHICAGO 5, ILLINOIS	1325 S. Wabash Avenue
CINCINNATI 10, OHIO	1714-16 Logan Street
CLEVELAND 14, OHIO	2128 Payne Avenue
DALLAS 1, TEXAS	300 S. Harwood Street
DENVER 5, COLORADO	2111 Champa Street
DETROIT 1, MICHIGAN	2312 Cass Avenue
INDIANAPOLIS 4, INDIANA	436 N. Illinois Street
KANSAS CITY 8, MISSOURI	233 W. 18th Street
LOS ANGELES 7, CALIFORNIA	1961 S. Vermont Avenue
MEMPHIS 2, TENNESSEE	412-414 S. Second Street
MILWAUKEE 3, WISCONSIN	1027 N. 8th Street
MINNEAPOLIS 3, MINNESOTA	56 Glenwood Avenue
NEW ORLEANS 12, LOUISIANA	220 S. Liberty Street
NEW YORK 36, NEW YORK	356 W. 44th Street
OKLAHOMA CITY 2, OKLAHOMA	700 W. Grand Avenue
PHILADELPHIA 7, PENNSYLVANIA	1225 Vine Street
PITTSBURGH 19, PENNSYLVANIA	86 Van Braam Street
ST. LOUIS 3, MISSOURI	3212 Olive Street
SAN FRANCISCO 2, CALIFORNIA	225 Golden Gate Avenue