

Film-Tech

The information contained in this Adobe Acrobat pdf file is provided at your own risk and good judgment.

These manuals are designed to facilitate the exchange of information related to cinema projection and film handling, with no warranties nor obligations from the authors, for qualified field service engineers.

If you are not a qualified technician, please make no adjustments to anything you may read about in these Adobe manual downloads.

www.film-tech.com

Simplex[®] 35

PROJECTOR MECHANISM
INSTRUCTION BOOK

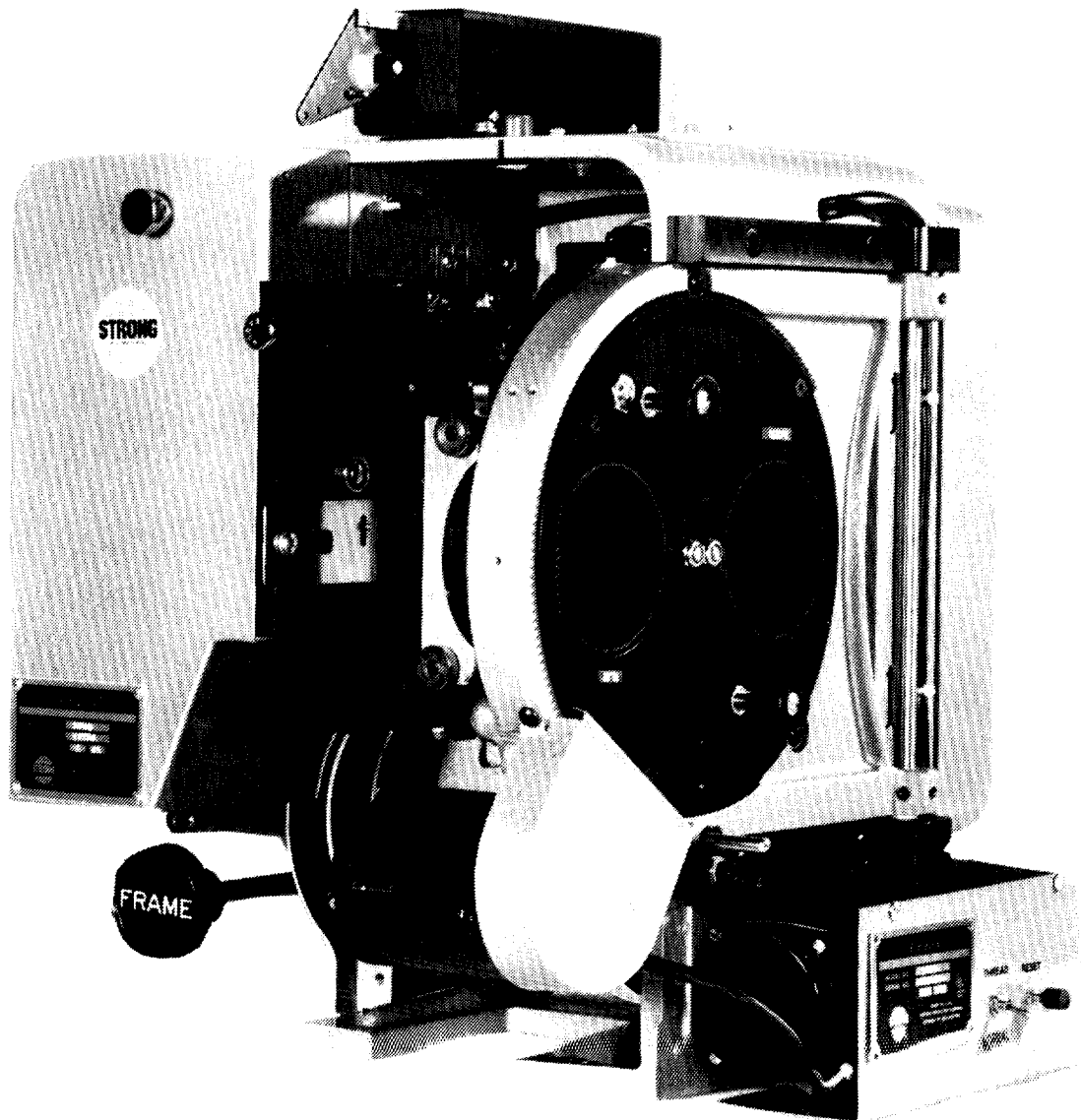

STRONG
INTERNATIONAL, INC.
4350 McKinley St.
Omaha, Nebraska 68112
402/453-4444 Telex 484481

MODEL 1050

with TU2000 Turret

TABLE OF CONTENTS

PREFACE	1
FIGURE 1	3
FIGURE 2	4
INSTALLATION	
Unpacking	5
Mounting	5
Lamphouse Alignment	6
Framing Lamp Transformer	6
Picture Changeover	6
Lens Turret	6
Lamphouse Light Shield	6
START-UP PROCEDURES	
Initial Oiling	7
Threading	8
Initial Operation	9
MAINTENANCE	
Lubrication	10
Sprockets	10
Pad Rollers	10
Fastening Hardware	10
Film Gate	10
Film Trap	10
Overall Appearance	10
FIGURE 3	11
FIGURE 4	12
FIGURE 5	13
FIGURE 6	14

TABLE OF CONTENTS (con't.)

ADJUSTMENTS & REPLACEMENTS

Intermittent Shoe Replacement	15
Intermittent Shoe Alignment	15
Film Gate Closure	15
Film Trap	15
Film Trap Lateral Rollers	16
Pressure Strap Replacement	16
Studio Guide Replacement	16
Gear Compartment Cover	16
Intermittent Movement	16
Shutter Timing	18
Framing Lamp	18
Oil Pump Feed Reversal	18
Film Sprocket Assemblies	19
Pad Roller Assemblies	19
Shutter Replacement	20

STRONG INTERNATIONAL, INC.
Engineering/Sales
April, 1991

PREFACE

THE SIMPLEX 35 PROJECTOR, Model 1050, combining rugged construction with ease of operation, provides theatre owners with a superior mechanism, engineered to the high standards set for all Strong International products. The following design features illustrate why the Simplex 35 Projector is able to provide continuously excellent performance throughout its long operating life:

UNIT DESIGN

Unit method of design simplifies part replacement and maintenance. All units may be quickly removed and replaced. Components within a particular unit are just as easily handled.

SOUNDHEAD

Although the Simplex 35 Projector was designed for use with the Simplex 5-Star Soundhead, other soundheads may be used without loss of quality.

MAIN DRIVE AND IDLER GEAR ASSEMBLIES

The main drive gear and idler assemblies are easily installed, insure proper driving from the soundhead, and are adjustable.

OPTICS

A conical shutter, positioned close to the picture aperture, provides very high light efficiency. Optical design is compatible to modern xenon lamphouse systems.

LENS TURRET

The TU2000 Lens Turret is available in either Automatic (TU2000E) or Manual (TU2000M) configurations. The turret accommodates (1) each 2-25/32" Wide Screen (flat) and Anamorphic (CinemaScope) lens without use of a MagnaCom. Two focus controls permit concise focusing of each lens independently. A dual aperture plate is filed for each format.

FILM COMPARTMENT

The roomy film compartment permits ease of threading and cleaning. The THREAD switch on the TU2000E swings the lens turret open for added convenience.

GEAR COMPARTMENT

The gear compartment has a removable cover, rounded corners, and an enameled finish which facilitates cleaning.

MAIN FRAME

The main frame forms a single unit with the base, top, and front that is noteworthy for its simplicity and strength.

FILM SPROCKETS

The upper feed, and lower holdback sprockets, having twenty-four teeth each, reduce shaft speeds to prolong operating life, permit smoother wrap-around, and lessen the danger of splice breakage. Exclusive use of VKF[®] sprockets insures minimum film wear. The pad rollers are made of durable, lightweight nylon.

FILM TRAP

The film trap conforms to the curved film gate, and accommodates the dual aperture plate used with the TU2000. The trap is easily removed and replaced for routine cleaning and maintenance.

FILM GATE

The curved gate, together with the film trap, controls the movement of the film past the aperture by five different tension settings. Gate curvature provides compensation for heat-induced warping of the film at the aperture, thus insuring a sharper image on the screen. The gate is easily removed, cleaned, and replaced.

INTERMITTENT MOVEMENT

The intermittent movement features a webbed starwheel for high strength, long life, and positive registration. The VKF[®] intermittent sprocket is adjustable, making absolute alignment possible.

LUBRICATION

A Spray-O-Matic Lubrication System, with a gear-driven oil pump, completely lubricates all moving components. The moving parts inside the gear compartment are visible through the glass panel in the full-vision oil-sealed cover. The intermittent movement lubricates itself by pump action, and the Spray-O-Matic system. An oil level sight glass in the film compartment permits a visual check of the oil level.

COOLING

The Simplex 35 Projector includes a standard air cooled trap. Water cooled traps may be ordered as an option, factory installed or field retrofit.

VKF[®] is a registered trademark of LaVezzi Precision, Inc.

Elmhurst, Illinois

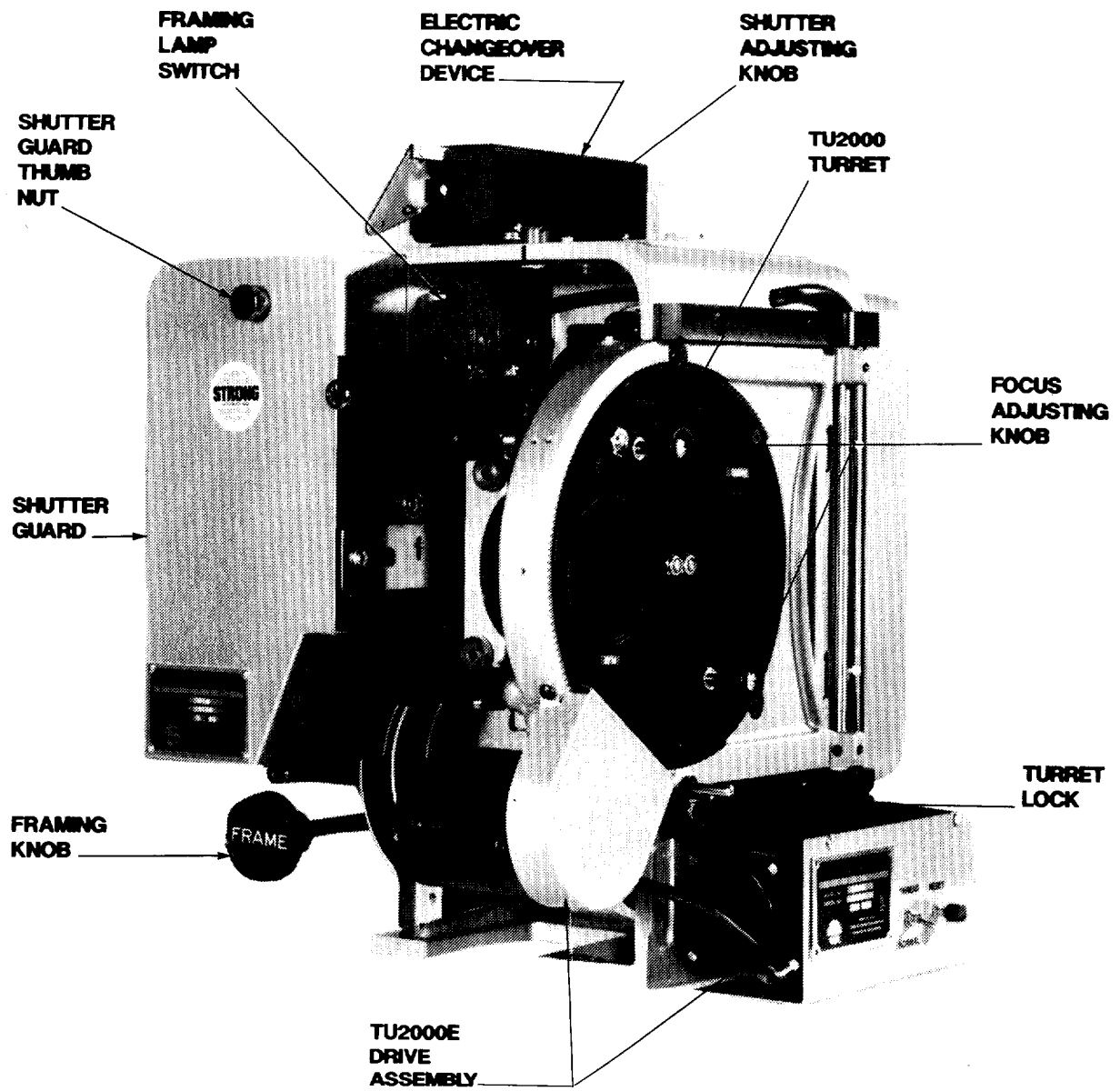

FIGURE 1

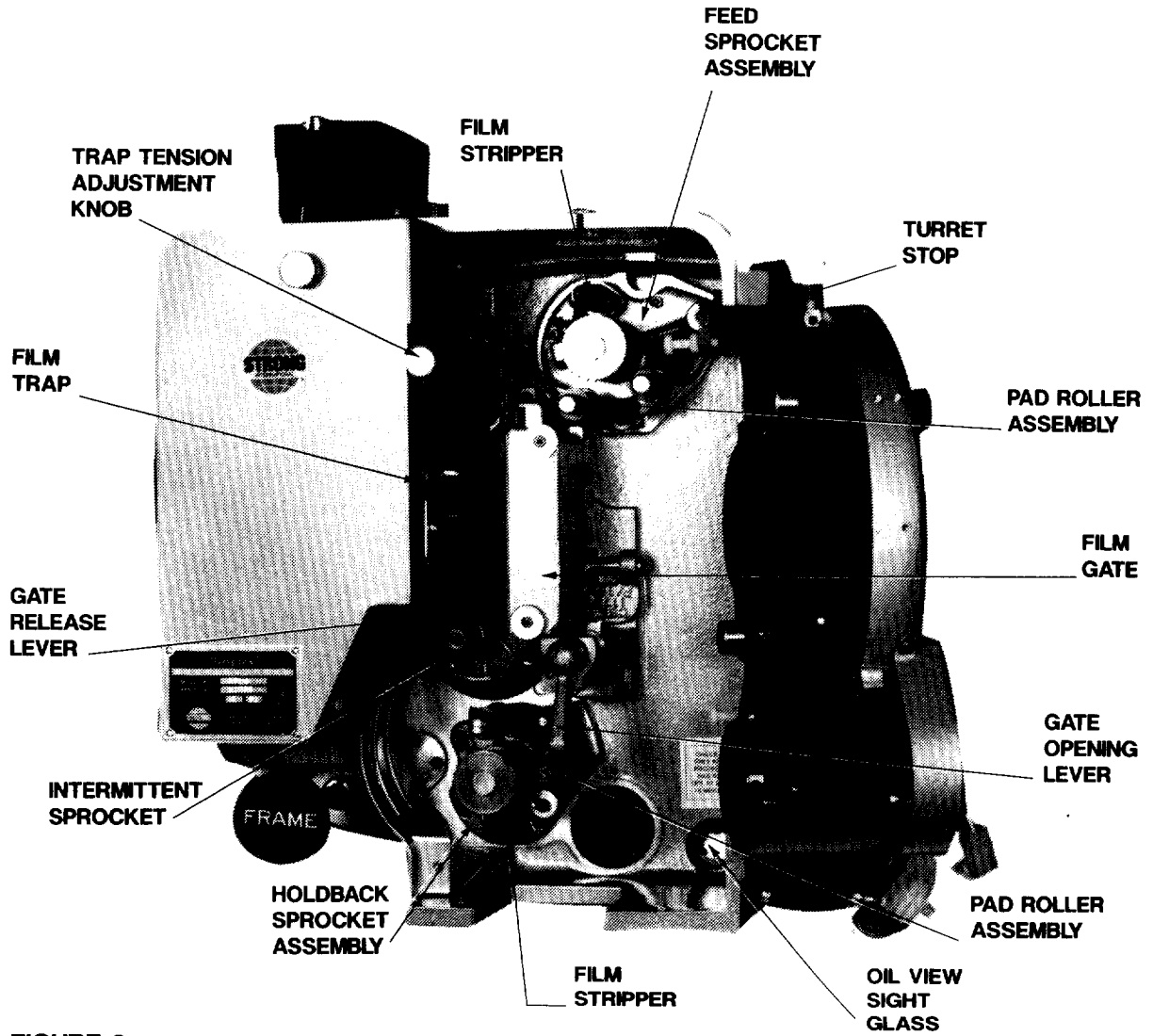

FIGURE 2

INSTALLATION

EACH SIMPLEX 35 PROJECTOR is carefully inspected and film tested before leaving the factory. Carefully inspect the unit on receipt for any shipping damage, and file any damage claims with the carrier **immediately**. It is the responsibility of the consignee, not Strong International, to file such claims.

THE FOLLOWING RECOMMENDATIONS should be studied carefully prior to installation. Your Strong International Dealer may wish to assist in installing those items supplied by him.

UNPACKING

The Simplex 35 Projector is shipped in a sturdy wooden crate. TOP and OPEN THIS SIDE are marked on the carton. The projector is mounted to the base of the crate with (2) 3/8-16 hex head screws. If shipped as an "All-In-One" system (including 5-Star soundhead), the soundhead is mounted to the base with (2) 5/16-18 hex head screws.

An accessory kit is shipped with each Simplex 35 Projector. The kit includes the following:

- (1) Can Simplex Projector Oil
- (1) Oiler
- (1) Set Allen Wrenches
- (1) Framing Lamp Transformer

The tools and accessories are required for adjustments and maintenance after installation. Keep them in a secure location in the projection booth.

MOUNTING

When not shipped as an "All-In-One" system, the projector must be mounted to the soundhead, after the soundhead has been installed to the projection pedestal or console. See Soundhead Manual.

The projector mounting bar is shipped with the 5-Star Soundhead. Mount the bar to the base of the projector using the (2) 3/8-16 socket head screws provided. Mount the projector to the top of the soundhead with the mounting bar in the channel on the top of the soundhead casting. Attach the mounting bar to the soundhead casting using the (2) 5/16-18 hex head screws and washers supplied. A slight degree of tolerance between the mounting bar and the soundhead casting permit positioning the projector for smooth film feed between the projector and soundhead. When correctly positioned, securely tighten all mounting fasteners. Run the drive belt to the projector and tension the belt with soundhead idler assembly.

LAMPHOUSE OPTICAL ALIGNMENT

Carefully follow the lamphouse manufacturer's instructions regarding correct optical alignment between the lamphouse and projector. The lamphouse is generally aligned to the projector aperture, but some consoles require positioning the projector and soundhead to the optical center of the lamphouse. DO NOT alter the film path between the projector and soundhead in the course of these adjustments. DO NOT operate the lamphouse with the douser open unless the projector is running.

FRAMING LAMP TRANSFORMER

Connect the (2) yellow leads of the transformer to the framing lamp leads running from the 90 degree connector at the top of the projector on the shutter housing. Shield leads in flexible conduit as required. Supply 120 V.AC to the (2) black transformer leads. The framing light switches ON and OFF by means of the pushbutton switch above the film trap inside the film compartment.

PICTURE CHANGEOVER

The Simplex 35 is normally supplied with either a G-2090 (Essannay) or G-2095 (Kelmar) 120 V.AC picture changeover device. Connect the changeover leads as follows:

G-2090

Blk - OPEN
Brn - CLOSE
Wht - COMMON

G-2095

Blk - OPEN
Red - CLOSE
Wht - COMMON
Grn - GROUND

NOTE: These changeover devices require a 120 V.AC **pulse** to operate. Connecting the changeover to a **sustained** 120 V.AC supply will destroy the electrical coil. Check carefully the instructions supplied with the automation controller or the (installer supplied) switching circuit.

LENSES, LENS TURRET

See the attached TU2000E Manual for wiring installation of the automatic turret assembly. Lens installation for either Manual or Automatic turret is detailed on Page 6 of the turret manual.

LAMPHOUSE LIGHT SHIELD

Light shields, or nose cones, supplied by the lamphouse manufacturer, may be installed between the projector shutter guard and the lamphouse snood. Make certain that the nose cone does not obstruct the rotation of the shutter. Trim or otherwise modify as required.

START-UP PROCEDURES

ALL SIMPLEX PROJECTORS are carefully "run-in" at the factory prior to shipping. No "run-in" period at the installation site is required. Some gear whine may be noticed initially, but should disappear after a few hours of operation.

INITIAL OILING

One quart of Simplex Projector Oil is included in the accessory kit supplied with new equipment. **USE ONLY GENUINE SIMPLEX PROJECTOR OIL IN THE MECHANISM.** Use of other lubricants may inhibit pump operation and damage moving parts. Additional oil is available through authorized Strong International Dealers; order Part No. R-0059 for (1) quart quantities.

DO NOT, at any time, operate the projector without oil.

Add oil through the filler located at the top of the gear compartment cover. The oil level is visible through the sight glass inside the film compartment at the base of the main frame. When the projector is level (0 degree projection angle), the correct oil level should be nearly to the top of the sight glass, with a small air bubble visible at the top.

As the machine is tilted to a downward projection angle, the air bubble will disappear. When the machine is started, the visible oil level will drop, indicating that the pump is drawing the oil from the reservoir and circulating it throughout the gear compartment.

If the machine is to be used in an extreme upward projection angle, the oil level will drop, and may disappear when the machine is running. In this event, it is recommended to install a G-4350 Drive-In Oil Gauge Mounting Kit (see Parts Catalogue, Page 1-18). The main frame is drilled to accept use of this kit.

Rotate the soundhead flywheel by hand to turn the projector mechanism. It should turn freely and smoothly. Start the projector motor and run for at least one minute. Check for an oil splash against the gear compartment cover glass.

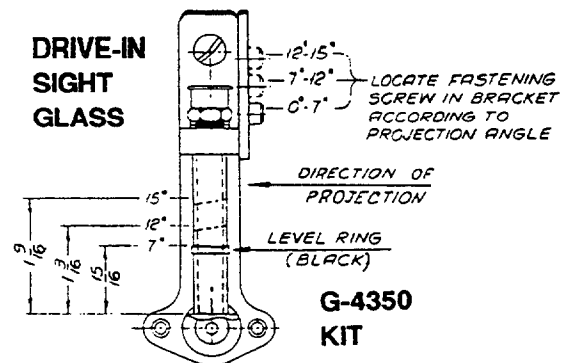
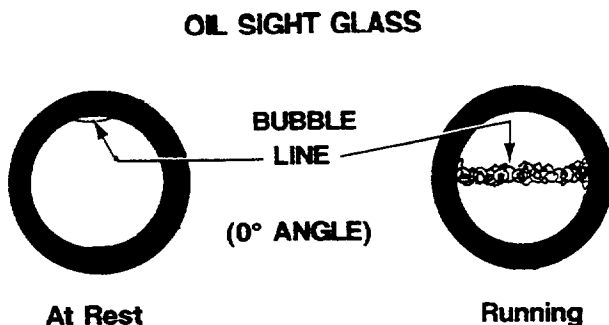

THREADING

Threading the projector correctly is one of the operator's most important duties. Careful attention during this operation pays off in improved performances and long print life.

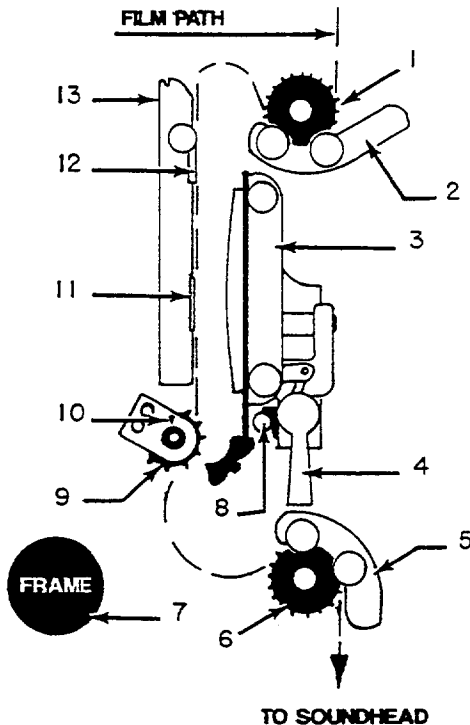

Rotate the framing knob (Item 7) to its center position (FRAME reading level, as shown). Using the soundhead flywheel, turn the mechanism by hand to place the intermittent sprocket (Item 9) in its "rest" position. In the "rest" position, the index mark (Item 10) will align with one of the painted white index marks on the intermittent shaft collar when stopping after sprocket rotation.

Open the pad roller assemblies (Items 2, 5). Open the film gate (Item 3) by moving the gate opening lever (Item 4) forward. The gate will lock in the open position (as shown).

At this time, it is advisable to dismount the film gate by removing the (2) chrome knurled nuts. Use a clean, dry cloth to wipe down all film bearing surfaces of the gate and trap (Item 13). Replace the film gate and nuts. This should be performed at each threading operation.

Thread the film as illustrated. Engage first the intermittent sprocket (Item 9), and check for correct framing at the framing aperture (Item 12). When correct, close the gate by tripping the gate release (Item 8). Form loops above and below the gate as illustrated, and close the pad roller assemblies (Items 2, 5).

Turn the mechanism by hand to advance a few frames of film. Run fingers over each sprocket (Items 1, 6, 9) to insure that the sprocket teeth are centered in the film perforations, and the film is centered in the sprockets. Check again the position of the film in the framing aperture (Item 12). A correct frame image in the framing aperture insures correct frame positioning in the picture aperture (Item 11). Use the framing knob (Item 7) to correct misframes.

Thread the soundhead as instructed in the soundhead manual. A slight degree of film tension is required above the feed sprocket (Item 1) and below the soundhead. This prevents the film from snapping on motor start.

CLEAN ALL FILM BEARING SURFACES BEFORE EACH THREADING OPERATION. Check all sprocket teeth for hooks or burrs; replace if required. Keep all pad rollers clean and operating freely.

INITIAL OPERATION

The Film Trap Tension Knob is located at the top of the film trap, and is numbered 1 - 5. Rotate this knob counterclockwise to its stop. This setting ("1") indicates minimum trap tension. Thread film into the projector, ignite the lamp, and project a picture to the screen. Use of RP-40 test film is highly desirable for this stage of machine set-up. This test film may be purchased directly from the Society of Motion Picture and Television Engineers:

SMPTE Test Film Department
595 West Hartsdale Avenue
White Plains, New York 10607

Order: 35 PA-50 (50 ft.)
or 35 PA-200 (200 ft.)

Install the lenses and set focus as detailed in the TU2000 Manual. File the apertures to fit screen parameters.

If the projected picture is unsteady, rotate the film trap tension knob clockwise **one step at a time**, while the film is running. Always adjust for the **minimum** tension required to project a steady picture. Excessive tension not only increases wear on parts, but in extreme cases may cause torn perforations and film breakage.

Check the projected picture for travel ghost. "Travel Ghost" is the term commonly applied to vertical streaking of lighter areas against a darker area, and is particularly noticeable during opening or closing titles and credits. If ghosting is apparent, rotate the shutter adjustment knob on the top of the projector until the ghosting disappears. If the ghost cannot be eliminated, see "Shutter Timing" in the ADJUSTMENTS AND REPLACEMENTS section of this manual.

MAINTENANCE

THE ENTIRE PROJECTOR MECHANISM should periodically undergo a careful and thorough inspection. A regular schedule of adjustments and replacement of wearing parts will insure long life and minimize downtime.

LUBRICATION

Drain and discard the projector oil at least annually. Clean the intake filter and the oil reservoir. Replace with genuine Simplex Projector Oil.

SPROCKETS

Examine each sprocket carefully for wear, undercutting ("hooks"), and/or looseness. Replace as required. Assuming the projector is used for forward-running only, hooked sprockets can be re-used by reversing the sprocket on its shaft. Check the alignment of the intermittent sprocket.

PAD ROLLERS

Check pad rollers for grooves, flat spots, and/or looseness. Clean rollers thoroughly to relieve binding; replace as required. Check alignment of pad rollers to sprockets; centered, flanges not rubbing, (2) film thicknesses above sprocket face.

FASTENING HARDWARE

Check all fasteners for tightness. Normal operating vibration may cause fasteners to loosen. Tighten as required.

FILM GATE

Remove all foreign matter (dirt, wax) by cleaning thoroughly. Examine film runners and intermittent shoes for wear; replace if required. Check alignment of intermittent shoes to intermittent sprocket faces. Check gate opening and closing levers for smooth operation; clean guide rods to relieve binding.

FILM TRAP

Examine lateral guide rollers for grooves and binding. Clean carefully, adjust, or replace. Remove all foreign material from tension straps. Inspect for wear; replace if required.

OVERALL APPEARANCE

Clean all enameled surfaces of the projector regularly. Oily surfaces will attract and hold dust and film particles.

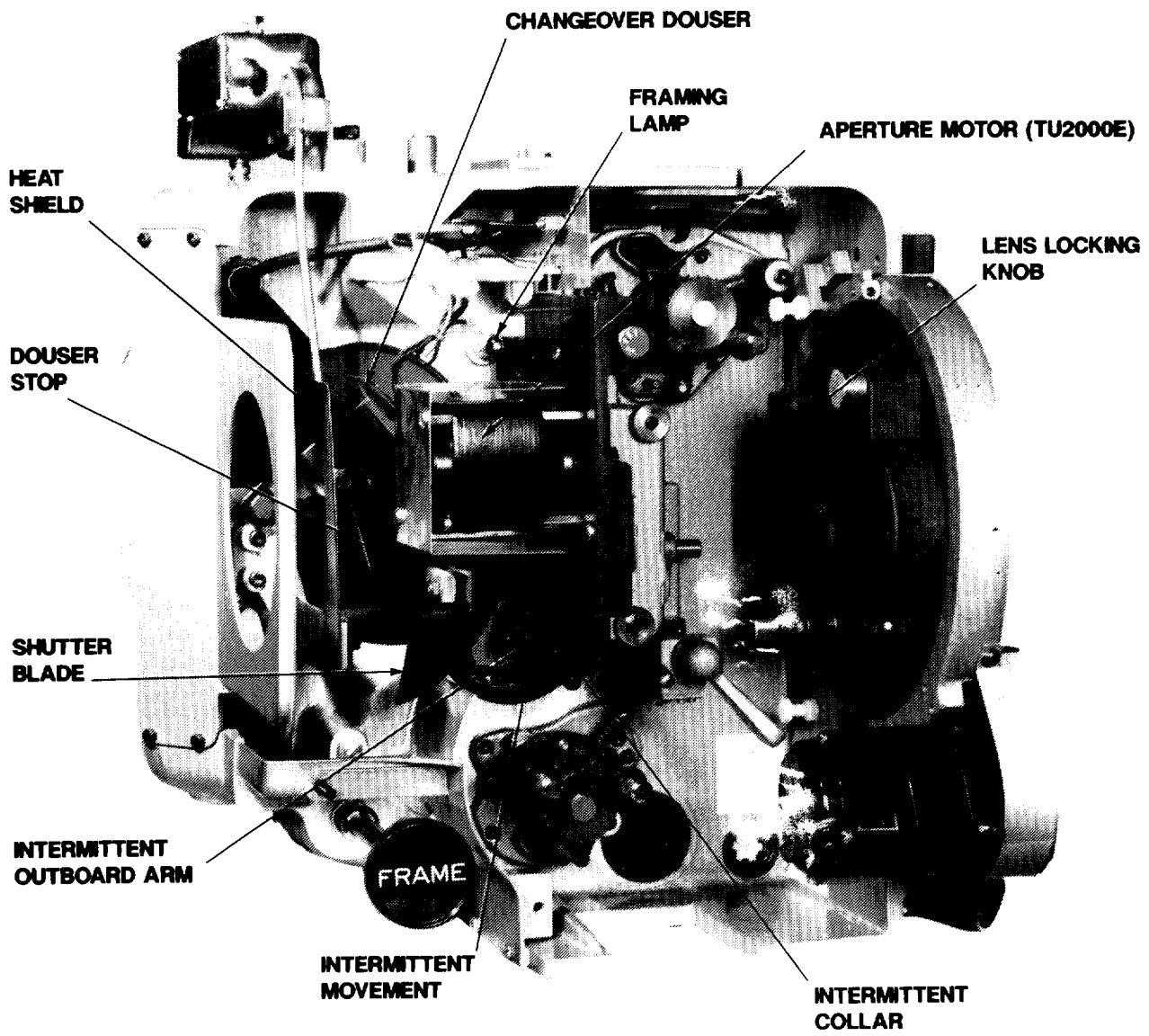

FIGURE 3

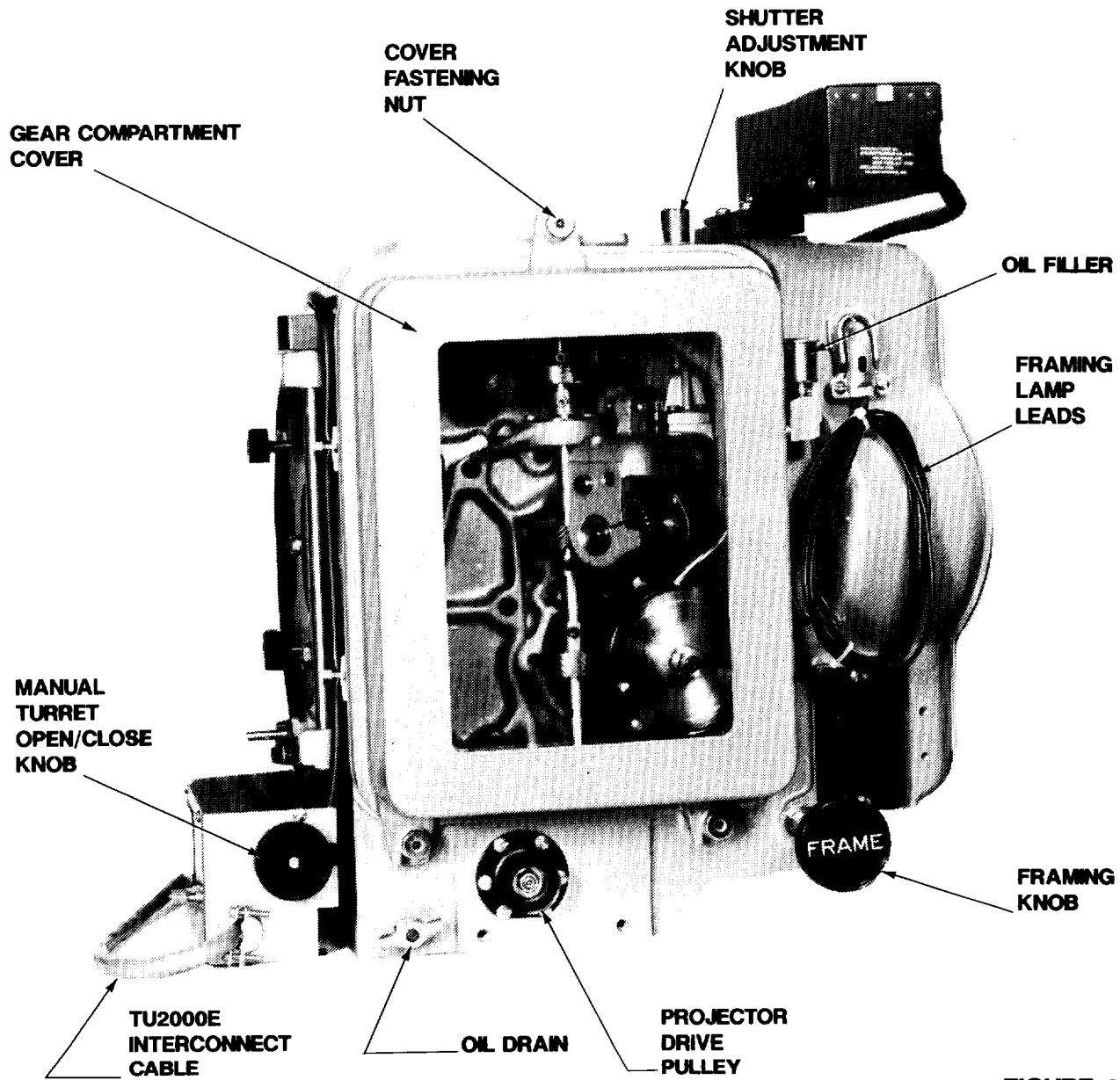

FIGURE 4

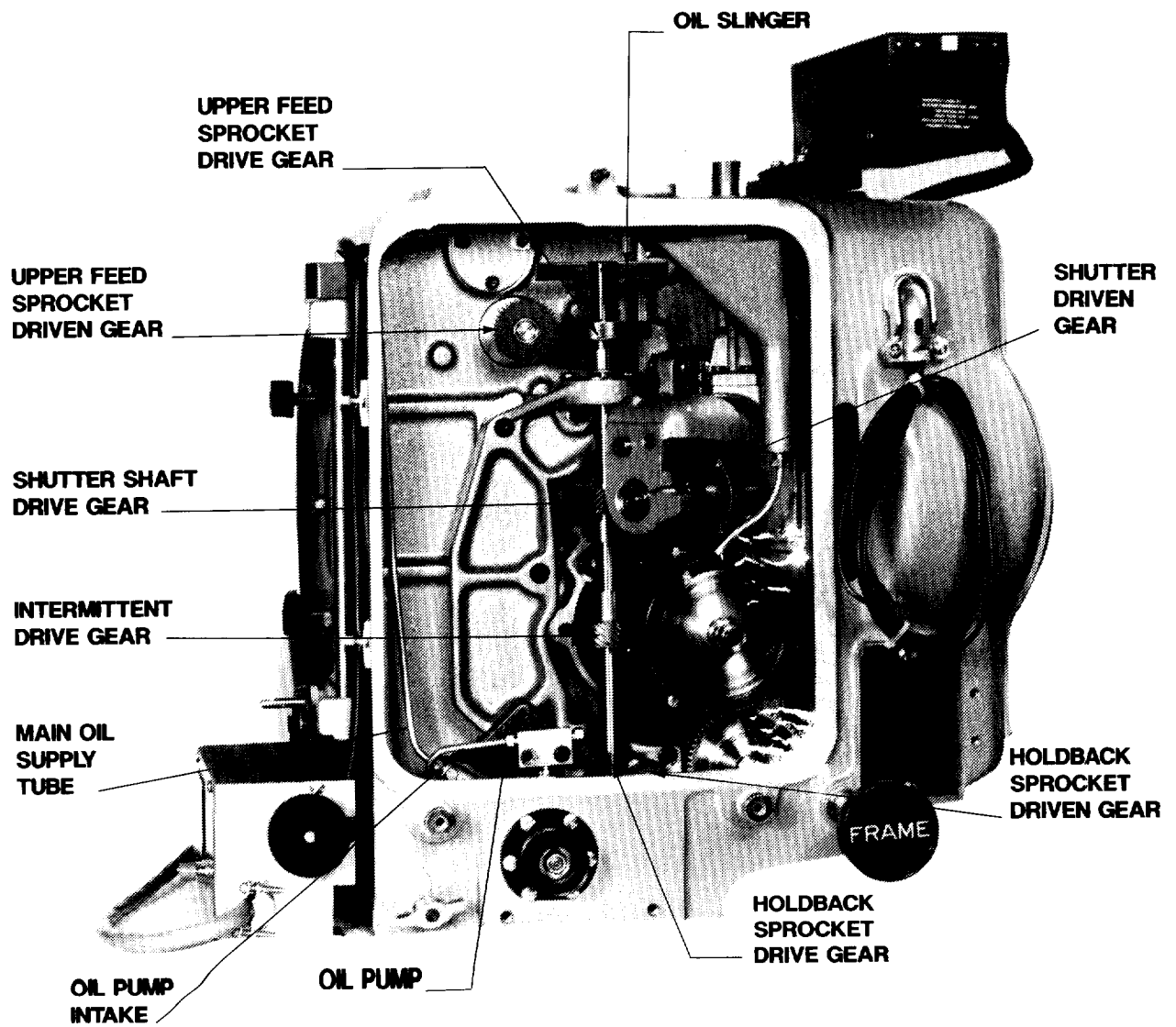

FIGURE 5

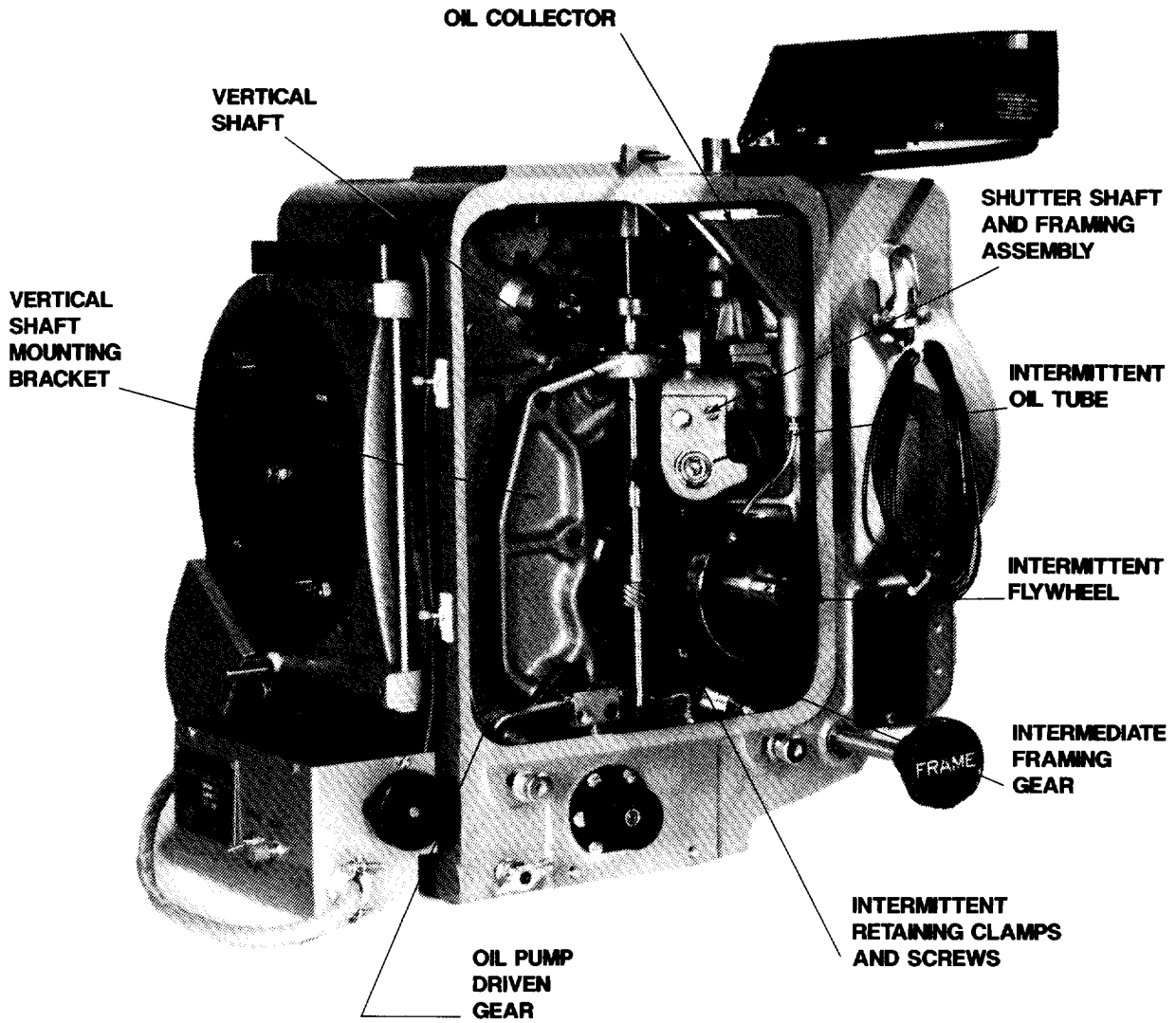

FIGURE 6

ADJUSTMENTS AND REPLACEMENTS

REFER TO THIS SECTION in conjunction with following the instructions in the MAINTENANCE section. Conscientious maintenance and service of the Simplex 35 will insure many years of excellent performance.

ADJUSTMENTS are quickly accomplished, and replacements performed, as all units and components are readily removed. Adjustments and replacements described below may be performed by qualified projection booth personnel. Any elements of maintenance and service not detailed below should be referred to an authorized Strong International Dealer.

INTERMITTENT SHOE REPLACEMENT

Remove film gate. Dismount the shoe assembly by removing the mounting screw and leaf spring. Replace worn components as required; check leaf spring for adequate tension. Reassemble and remount.

INTERMITTENT SHOE ALIGNMENT

Place a straight edge across the outboard face of the intermittent sprocket and the outer face of the the tension shoe. Loosen the intermittent shoe assembly mounting screw, and slide the shoe assembly, as required, for exact alignment. Tighten mounting screw securely.

FILM GATE CLOSURE ADJUSTMENT

Open the lens turret and dismount the film gate. Insert a pin or allen wrench in one of the holes in the tension collar on the operating lever shaft. Loosen the locking screw in the bottom of the operating lever assembly bracket, located through the casting below the tension collar. Rotate the collar counterclockwise using the pin or allen wrench until the next hole is aligned to the locking screw. Tighten the locking screw. Repeat this adjustment procedure until proper closing tension is obtained.

FILM TRAP AND APERTURE CHANGER ASSEMBLY

Dismount the film gate and the shutter guard. Turn off power to the TU2000E turret. Loosen the single captive film trap mounting screw located between the trap tension knob and the sliding dual aperture plate. Unplug the aperture change motor (TU2000E only). Pull the trap assembly straight out from the projector main frame. To replace, make certain that the contacting surfaces on both the main frame and the trap casting are clean. Slide the film trap in so that it registers with the (2) dowel pins on the main frame. Securely tighten the captive screw. Plug in the aperture change motor (TU2000E only). Check the alignment of the intermittent sprocket to the film trap (see INTERMITTENT MOVEMENT section following).

FILM TRAP LATERAL GUIDE ROLLERS

Dismount film trap and associated components (see above). Loosen the (2) lateral roller pivot set screws. Slide the lateral roller pivots out of the casting and remove the lateral rollers and spring. Replace worn parts and reassemble. NOTE: For ease of threading, the spring-loaded lateral roller should be installed inboard. Position the fixed (outboard) lateral roller to the outboard edge of the film path. The horizontal positioning of the lateral rollers is determined by sliding the rollers and pivots in the trap casting. Center the rollers in this manner to the film path. Leave enough end play in the pivots to permit free rotation of the lateral rollers, and tighten the (2) pivot set screws.

PRESSURE STRAP REPLACEMENT

Dismount the film trap and associated components. Rotate the trap tension knob fully counterclockwise to position "1". Remove the (2) screws from each strap, and remove the straps. Replace with new straps and reassemble. NOTE: Reset trap tension with film projected (see START-UP PROCEDURES).

STUDIO GUIDE REPLACEMENT

Remove the film gate and open the turret assembly. Remove the (2) flat socket head screws and dismount the studio guide. Position and install the replacement studio guide; close the turret and replace the film gate.

GEAR COMPARTMENT COVER REMOVAL

Only when absolutely necessary, remove the gear compartment cover and only after the machine has been at rest for at least (10) minutes to allow all oil to settle into the reservoir. Remove the (3) cover fastening thumb nuts. Make certain no foreign material deposits in the gear compartment while the cover is removed. Before replacing the cover, wipe all oil from the cover gasket and the mating surface on the projector main frame. Any oil remaining on these surfaces will provide an oil seepage path after the cover is replaced. Tighten all (3) thumb nuts equally and fingertight, just enough to form an oil-tight seal.

INTERMITTENT MOVEMENT REPLACEMENT

1. Open the film gate. Rotate the framing knob (on the gear side) fully counterclockwise.
2. Set the shutter adjusting knob in mid-position. To locate mid-position, rotate the knob to its stop, and reverse 1-1/2 turns.
3. Remove the gear compartment cover (see above).
4. Rotate the vertical shaft until the intermittent drive gear mounting screw is visible. Remove the mounting screw and slide the gear downward.
5. Loosen the (2) intermittent retaining clamp screws on the framing cam and position the clamps to clear the intermittent case.

INTERMITTENT MOVEMENT REPLACEMENT (con't.)

6. Withdraw the intermittent assembly from the gear compartment side, taking care not to strike the intermittent oil feed tube positioned above the intermittent assembly.
7. Slide the replacement intermittent movement into position. The keyway in the intermittent case is aligned with the key in the framing cam.
8. Rotate the intermittent retaining clamps to retain the intermittent assembly and tighten the fastening screws securely.
9. Rotate the shutter counterclockwise (from rear of projector) until its leading edge is exactly in line with the upper edge of the picture aperture (aperture just completely blocked).
10. Rotate intermittent flywheel until the intermittent sprocket turns clockwise (1) of the (4) index lines on the outboard collar is aligned with the index line on the outboard bearing support arm.
11. Continue to rotate the flywheel in the same direction until the intermittent sprocket just begins to move.
12. Reverse rotation of the flywheel until the sprocket stops. Then, rotate the flywheel counterclockwise until the start of sprocket rotation is felt.
13. Continue to rotate the flywheel until the precise point at which the sprocket is about to move is reached. Retain that setting.
14. Raise the intermittent drive gear and rotate it tooth by tooth until it meshes with the intermittent driven gear. At this time, the mounting hole in the drive gear should align with the hole in the vertical shaft. Do not rotate the vertical shaft or driven gear. Replace the gear mounting screw.
15. Align the intermittent sprocket with the film trap (see below).

INTERMITTENT SPROCKET ALIGNMENT

Loosen the intermittent sprocket fastening screw and slide the sprocket, as required, until the outside face of the sprocket is flush with a straight edge placed on the outside face of the lower holdback sprocket. Securely tighten the intermittent sprocket fastening screw.

INTERMITTENT SPROCKET REPLACEMENT

1. Remove film gate. Dismount shutter guard and film trap.
2. Rotate the framing knob to its extreme clockwise position to expose the intermittent sprocket film stripper mounting screw. Remove the screw and stripper.
3. Turn the projector mechanism by hand so that one of the collar index lines aligns with the index mark on the outboard arm, and the sprocket mounting screw is exposed.
4. Remove the intermittent sprocket mounting screw and nut.
5. Loosen the (2) intermittent outboard collar set screws and remove the collar.
6. Remove the (2) outboard arm socket head mounting screws and dismount the outboard arm.
7. Remove the intermittent sprocket. Slide replacement sprocket onto shaft.

INTERMITTENT SPROCKET REPLACEMENT (con't.)

8. Position the intermittent outboard bearing arm on intermittent sprocket and start the (2) socket head mounting screws finger tight. Adjust the bearing arm, as required, so that the bearing is precisely centered with respect to the intermittent shaft. Tighten the (2) mounting screws.
9. Fasten the replacement intermittent sprocket to the intermittent shaft using the screw and nut supplied.
10. Slide the intermittent outboard collar on the intermittent shaft and align one of its index lines to the index mark on the outboard bearing arm. Pull the intermittent sprocket OUT while pressing the outboard collar IN, so that shaft end play is just perceptible.
11. Securely tighten the (2) collar set screws. Check that the shaft end play is just perceptible.
12. Replace intermittent sprocket film stripper.
13. Align the intermittent sprocket (see above).
14. Replace film trap and shutter guard. Install the film gate and align the intermittent shoe assembly as required.

SHUTTER TIMING

Place the shutter adjusting knob in its mid-position (see INTERMITTENT MOVEMENT REPLACEMENT, Step 2). Remove the shutter guard. Turn the projector mechanism by hand so that the index mark on the intermittent outboard bearing arm is centered between two of the collar index lines. Loosen the (2) socket head shutter hub clamping screws. Rotate the shutter to the fully closed position (one blade completely covering the film aperture). Tighten the (2) clamping screws. Replace the shutter guard. Check projected picture; fine adjustment of the shutter adjustment knob may be required to eliminate travel ghost (see START-UP PROCEDURES).

FRAMING LAMP BULB REPLACEMENT

Remove shutter guard. Remove framing lamp bulb. Insert replacement bulb into socket; twist to seat. Replace shutter guard.

FRAMING LAMP SWITCH REPLACEMENT

Remove shutter guard. Desolder switch leads from switch terminals. Replace switch and resolder leads to replacement switch. Replace shutter guard.

OIL PUMP FEED REVERSAL (Drive-In Theatre Operation)

See PARTS CATALOGUE, Page 1-20. Remove gear compartment cover. Remove compression nut, compression bushing, and oil line and filter from the left-hand side of the oil tube connector. Reconnect parts in sequence on the right-hand side, and tighten. Install the Drive-In Oil Gauge Assembly (G-4350) if desired (see PARTS CATALOGUE, Page 1-18).

FEED AND HOLDBACK SPROCKET ASSEMBLIES REMOVAL

From the film compartment side, remove the (4) socket head mounting screws retaining the sprocket assembly to the projector main frame. Withdraw the assembly from the film compartment. Make certain that the gasket is in the groove in the sprocket assembly casting. When replacing, start the mounting screws finger tight. Position the assembly so that there is slight backlash between the meshing gears. The (4) mounting holes in the casting are sufficiently oversize to permit this adjustment. Tighten the mounting screws and check gear backlash. Adjust as required.

FILM SPROCKET REPLACEMENT

1. Remove (1) of the (2) film stripper mounting screws. Loosen the other mounting screw and rotate the stripper to clear the sprocket.
2. Open the pad rollers.
3. Remove the hex head sprocket fastening screw from the outboard end of the sprocket shaft and slide the sprocket from the shaft. Leave the spring washer and flat washer on the shaft.
4. Slide the replacement sprocket (G-6611) onto the sprocket shaft, aligning the key in the sprocket with the keyway in the shaft. Secure with the sprocket fastening screw.
5. Replace the film stripper.

FILM SPROCKET DRIVEN GEAR REPLACEMENT

1. Remove film sprocket assembly as a unit (see above).
2. Remove gear fastening screw and slide gear from shaft.
3. Slide replacement gear onto shaft. Insert the fastening screw, position the gear to allow slight end play, and securely tighten fastening screw.
4. Replace sprocket assembly and adjust for backlash (see above).

PAD ROLLER ASSEMBLY REPLACEMENT

1. Remove film sprocket assembly as a unit (see above).
2. Open pad rollers, compress actuating spring on the sprocket assembly so that the small hole in one arm of the forked spring guide is accessible. Pass a pin or paper clip through this hole to relieve the spring tension.
3. Remove pad roller assembly mounting screw and dismount pad roller arm.
4. Replace worn components as required, reassemble, and remove the pin from the spring guide. Spacer washers, if used, are retained in their original positions. Make certain that the pad rollers are centered directly over the film sprocket.
5. Position pad roller arm adjusting screw on the sprocket assembly casting so that, with (2) thicknesses of film between the sprocket and pad rollers, both pad rollers just rotate. Ensure that the adjusting screw locknut is then securely tightened.
6. Reinstall sprocket assembly and adjust for backlash (see above).

SHUTTER REPLACEMENT

Remove the shutter guard. Disconnect the linkage to the changeover douser. Remove the (4) socket head mounting screws from the rear cover, and dismount the cover. Loosen the (2) shutter hub clamping screws and dismount shutter. Install replacement shutter and set shutter time as detailed above. Replace the rear cover, douser linkage, and shutter guard.

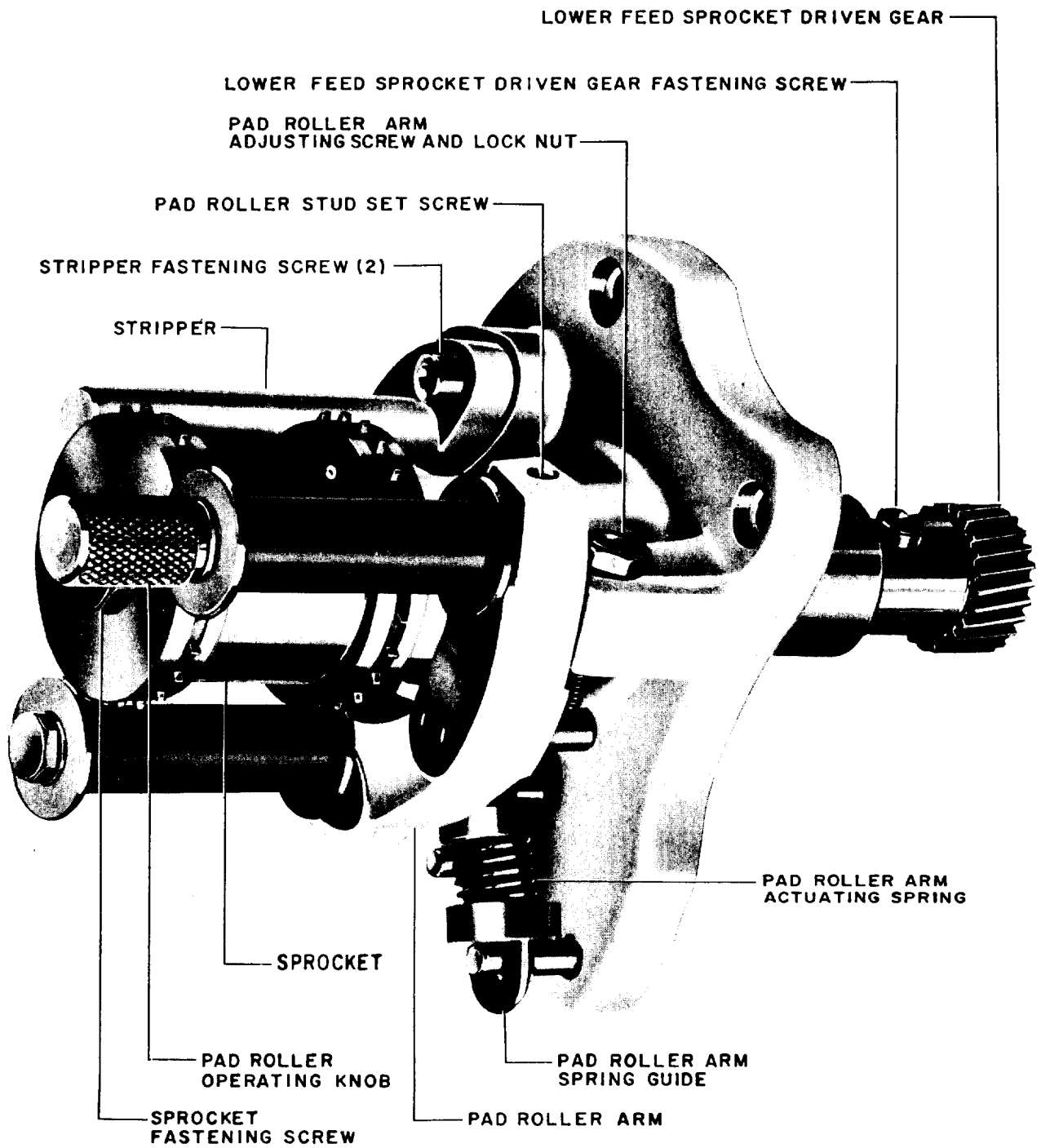

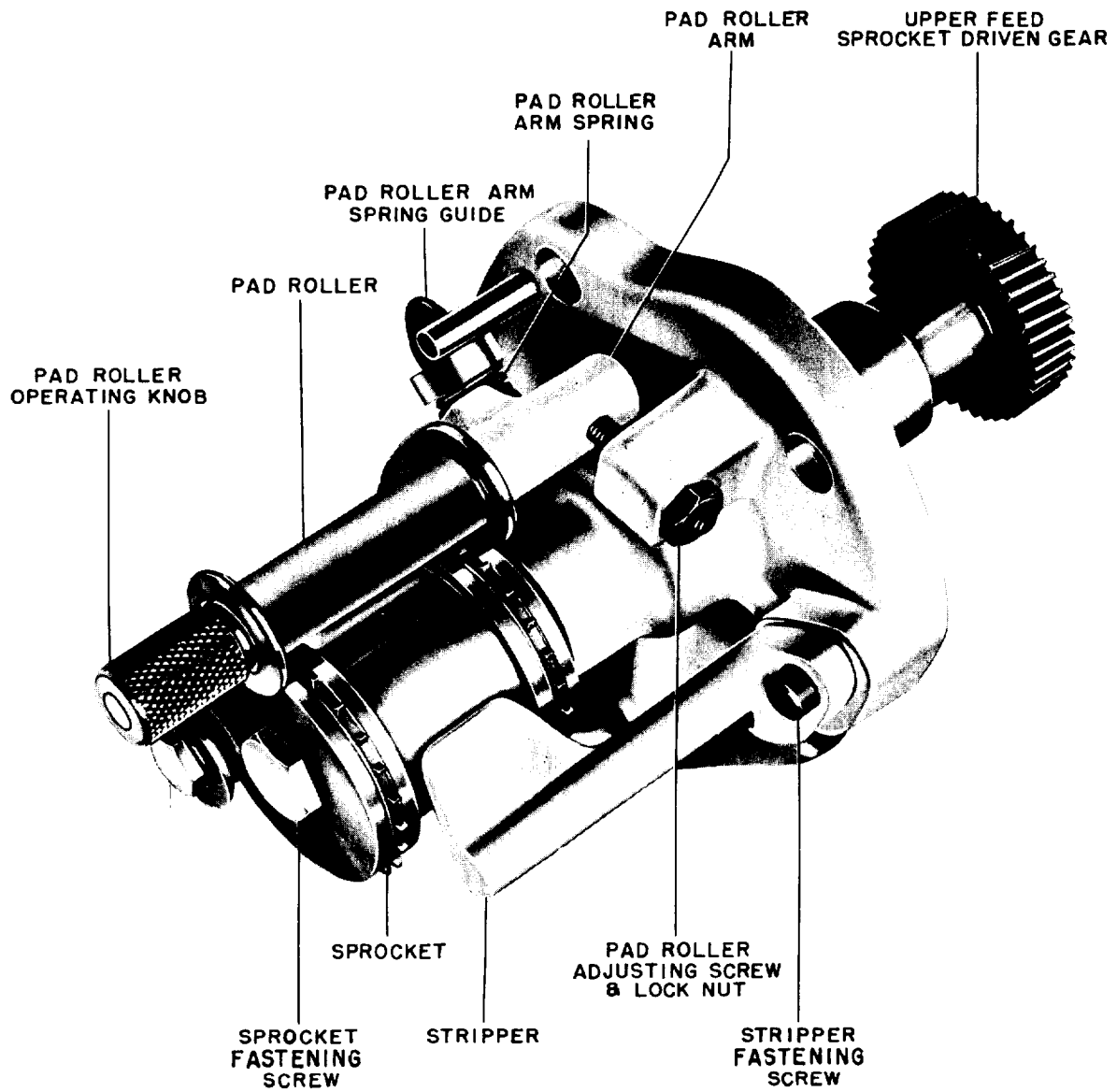

**LIMITED WARRANTY
FOR
SIMPLEX® PRODUCTS**

Ballantyne of Omaha, a wholly owned subsidiary of Canrad-Hanovia, (referred to as the "Seller") warrants any Simplex products, sold to the original Buyer only, to the extent necessary to correct any defects in materials or workmanship in any parts thereof under normal use and service for a period of one year from date of shipment to Buyer.

Seller's obligation is limited to the repair or replacement of such parts when examination shall disclose them, to Seller's satisfaction, to have been defective. Such parts shall be returned to Seller within a reasonable period of time after occurrence of the alleged defect, transportation charges prepaid by Buyer. The replacement or repaired part will be returned to the Buyer at the Buyer's expense. It is understood that no allegedly defective part is to be returned to the Seller unless such return has been authorized by the Seller.

This warranty does not apply to the parts of any Simplex products which have been opened, disassembled, repaired or altered by anyone other than Seller or its authorized agent or subjected to misuse or abuse.

THE FOREGOING WARRANTIES ARE IN LIEU OF ALL OTHER WARRANTIES, EXPRESS OR IMPLIED, INCLUDING, WITHOUT LIMITATION, WARRANTIES OF MERCHANTABILITY AND FITNESS FOR ANY PARTICULAR PURPOSE. IN NO EVENT WILL SELLER BE LIABLE FOR INCIDENTAL, CONSEQUENTIAL OR SPECIAL DAMAGES FOR ANY BREACH ARISING OUT OF THE SALE OF ANY SIMPLEX PRODUCTS OR PARTS THEREOF TO BUYER.

This warranty gives you specific legal rights, and you may also have other rights which vary from state to state.

Return Authorization Required for All Returned Items.

Contact Strong International Customer Service Department for R.A.