

Film-Tech

The information contained in this Adobe Acrobat pdf file is provided at your own risk and good judgment.

These manuals are designed to facilitate the exchange of information related to cinema projection and film handling, with no warranties nor obligations from the authors, for qualified field service engineers.

If you are not a qualified technician, please make no adjustments to anything you may read about in these Adobe manual downloads

www.film-tech.com

Victoria 8

70-35

*Istruzioni per installazione,
funzionamento e manutenzione*

*Instructions pour installation,
fonctionnement et entretien*

*Installation, operation and
maintenance manual*

I N D E X

Page

- Equipment Picture	2
- Index	3
- Figures Index	4
- General Description	5
- Projection Room Layout	8
- Hints on Installation	
Specification of Dual Equipment	9
Cases Contents	10
Standard Tools	11
- Equipment Assembly	
Pedestal Stand - Projector Base - Lamphouse beam	12
Projector - Spool Boxes	13
Sound Head and preamplifiers	14
Electrical and water cooling connections	15
- Preparing projectors for operation	17
- Adjustments	24
- Projector running checks	27
- Maintenance	29
- Lubrication	30
- Defects and Causes	31
- Replacement of the Intermittent Unit	32

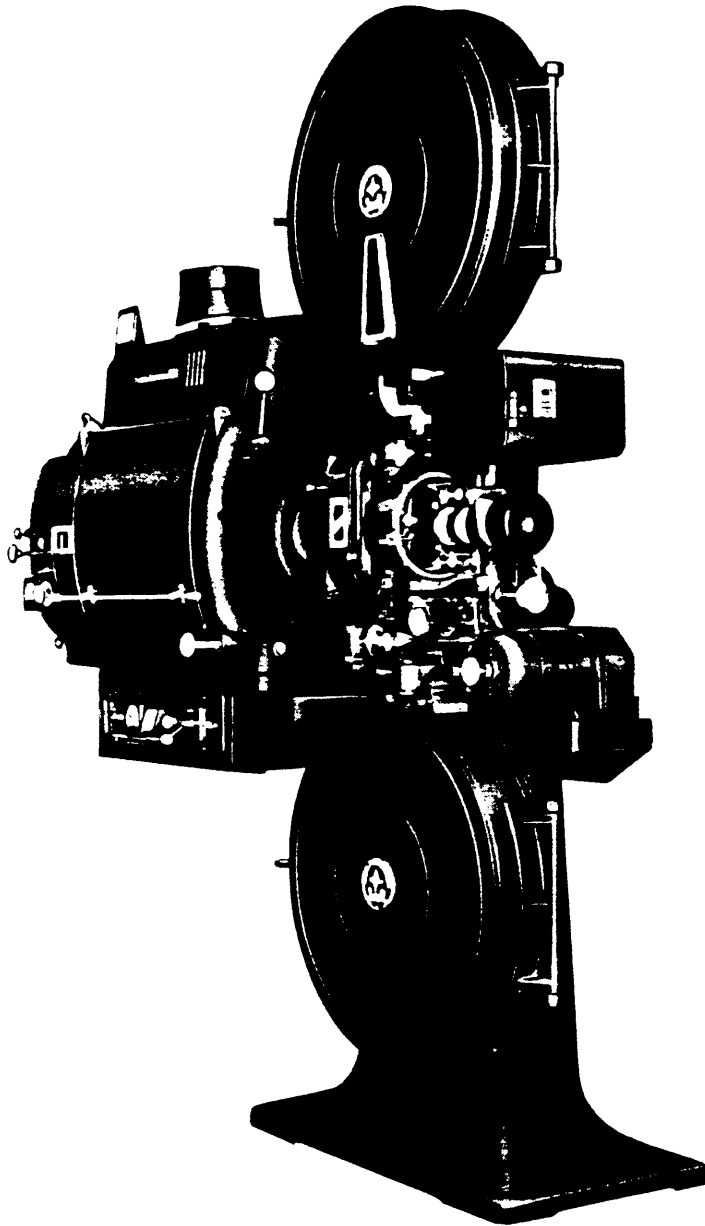

Apparecchio sonoro *Victoria 8*
per film 70 e 35 mm. - tipo aperto con tourelle
con arco a specchio SuperZenith 450

Appareil sonore *Victoria 8*
pour film 70 et 35 mm. - type ouvert avec tourelle
avec lanterne SuperZenith 450

Victoria 8 projector for 35/70 mm.
films, open model with lens turret
and SuperZenith 450 arc lamp

FIGURES INDEX

Figures	Page
1 - Overall dimensions	51
2 - General Installation Wiring Diagram	52
3 - Recommended Portholes layout	53
4 - Pedestal Stand	54
5 - Projector Base	54
6 - Lamphouse Beam	54
7 - Projector operating side (right hand)	55
8 - Projector non-operating side (left hand)	55
9 - Spool Boxes	56
10 - Magnetic Soundhead	56
11 - Enclosures	56
12 - Exciter lamp power Units	57
13 - Lens Holder Turret	58
14 - Single Lens Holder	58
15 - Gate Bracket	58
16 - 35 and 70 mm. Gates	59
17 - Air and Water cooling	59
18 - Shutter Housing and Controls	59
19 - Change over Controls	60
20 - Picture Change over Control	60
21 - Lubrication	61
22 - Optical Soundhead	61
23 - Film Threading: 35 Optical - 35 Magnetic and 70mm.	62
24 - Instructions for changing from 70mm. projection to 35mm.	63
25 - Intermittent Unit Replacement	64

GENERAL DESCRIPTION

The VICTORIA 8 Equipment is designed to project any standard 35 mm. and 70mm. film.

When supplied as a 35mm. unit, it will project normal, wide screen, CinemaScope, Vista Vision films with optical and magnetic single or multi track sound.

When supplied as a 70mm. unit, it will project all standard 70mm. films with provision for reproduction from 6 or more magnetic sound tracks.

It can be connected both mechanically and electrically with other soundheads or other equipment.

It will accomodate all types of lamphouses, either Xenon Lamps or Carbon Arcs, manufactured by Cinemeccanica as well as by other makes.

Equipment Main Assemblies

Pedestal stand manufactured from cast iron is designed to provide complete stability when in use. On the non-operating side (left hand) a rear cover is fitted which, when removed, allows full access to the various terminal boards and power supply units, mounted inside the stand base. There are two holes at each of the four corners of the base. One is to accommodate the stand levelling bolts and the other for providing fixing to the floor should this be required. On the upper part of the stand the elevating screw assembly is fitted for adjusting the projection angle.

The beam is attached to the pedestal stand by two pivot screws located towards the front of the pedestal stand and can be locked by two screws located towards the rear of the pedestal stand. The pivot movement provided will give control over a projection angle of 5° positive and 18° negative. The beam supporting the lamphouse is secured to the projector beam with bolts and according to the specification, adaptors can be supplied to provide variable optical heights to the projector centre according to the type of lamphouse to be used. On the lamphouse beam, the control panel is fitted on the operating side and fuses and terminals on the non-operating side. Variations in the type of controls required can be made to meet customer's requirements. Upon request, a special adjustable lamphouse table support can be supplied for use with various types of American Arc Lamps.

Top and bottom spool boxes will accommodate a spool having a capacity of 1,800 metre (approximately 6,000 ft) and are constructed with a main cast aluminium back plate and sheet steel housing. The bottom spool box back plate is secured to the projector base and carries the take-up spindle, clutch and drive pulley, and is driven from the projector by means of a timing belt.

Projector mechanism

The projector drive motor is fitted into the front end of the projector base and the drive to the projector mechanism is by means of a timing belt which ensures complete freedom from any vibration. Changes can be made to the motor drive pulley to meet variations in the frequency of the supply available. The complete projector mechanism is totally enclosed in a Silumin casting fitted with an easily removable rear cast cover. The parallel helicoidal gears are hobbled on a Red Ring machine and the selection of different materials makes the gears completely noiseless in operation.

The sprockets are manufactured on a special machine which allows the metal between the teeth to be under-cut so that the film, when passing over the sprocket is in contact with the drum of the sprocket and not the root of the teeth.

The Maltese cross and cam assembly are standard and are as used on all Cinemeccanica projectors, a design which has proved to be completely reliable over many years.

The Maltese cross movement turns the intermittent sprocket 90° allowing the maximum acceleration possible to maintain film in first class condition.

The gate plate and the curved gates are readily interchangeable according to the type of film to be projected.

The gate plate is rigidly constructed from steel. The areas in contact with the film are mirror polished as are also the four adjustable pressure pads in the gate frame. The gate frame is the parallel opening type.

The aperture plates are readily interchangeable for different ratios and can be exchanged, if required, with the projector running.

The two-bladed conical shutter provides the highest possible light efficiency.

A safety dowser is fitted between the light source and the conical shutter and operates automatically if the film breaks. This safety dowser is also used for picture changeover between projectors and also sound change control.

It can also be fitted with a solenoid control to provide automatic operation when required.

Lubrication

The projector mechanism carries an oil sump. The oil is circulated to all moving parts of the mechanism by an oil pump. The oil passes through two separate filters, and an oil flow and oil level windows are provided.

Lens holders

Two types of lens holders are available. One, carrying three lenses (two 62.5mm. diameter and one 70,6mm. diameter) in a rotary turret which also carries a supplementary bracket for the anamorphic lens. The three lenses can be easily rotated for projection of any film ratio. Each lens is independently focussed. The other one is a single lens holder for lenses having a maximum diameter of 5". Suitable lens sleeves are available so that all types of lenses can be accommodated. The lens mount can be fitted with motorised remote focus control if required. An anamorphic hinged lens bracket is available and can be adapted for use with different types of lenses.

Cooling

An independent motor blower is fitted to the projector providing direct air cooling to the film. The projector gate and shutter housing are also water cooled.

Optical Soundhead

The soundhead unit is mounted directly onto the projector and is complete with a reproducing drum fitted with oil damper and flywheel, the optical objective lens is adjustable, the exciter lamp has a prefocussed socket; the soundhead can be supplied with photoelectric cell or with a photojunction alternatively.

Magnetic Soundhead

This is fitted on the front wall of the projector casting and carries a flywheel assembly and an oil damper.

It is supplied as a standard unit with 10-track magnetic cluster on the Victoria 8 - 70/35mm. model and with 4-track magnetic cluster on the Victoria 8 - 35mm. Six-track and special clusters are available if required.

Electrical Installation

The wiring of the Projector stand and control units can be made in accordance with Customer's local regulations and requirements.

PROJECTION ROOM LAYOUT

It is recommended that the section "Hints on Installation" be read before proceeding with any work.

The layout of the projection room will vary according to the specification of the equipment being installed and the local projection conditions.

Drawing Fig. 1 Projector, Overall Dimensions

Drawing Fig. 2 General Installation Wiring Diagram

Drawing Fig. 3 Recommended porthole layout

refer to standard 35mm. projection equipment and the information given is provided to facilitate the design and layout of the projection room.

The projectors, the sound system and the master electrical panel are to be located in accordance with booth size and shape, with projection distances and angles and with the sound system type.

Fig. 3 - This drawing shows the suggested position of the projection and observation ports. (Porthole locations are shown from inside booth facing screen).

Fig. 1 - A table is shown giving the variations in projection port centres (h) according to the projection angle at which machines will operate. Height of observation ports may also be determined and adjusted accordingly.

Fig. 2 - This diagram shows a recommended conduit layout for a standard electrical installation covering the supply to projectors, amplifiers, speakers, generators and/or rectifiers for Arc supply.

The number of cables and sizes required are also shown.

Stranded wires are recommended for the booth wiring.

Electrical conduits should be located beneath the projector stand within the area marked (A) (Fig.3). Water cooling pipes, if required, must protrude 10 cmts (B) from beneath the stand Fig.3. The water supply must circulate freely (See Fig.17), and a regulating tap must be fitted in the feed pipe.

Pipe fittings should be 10mm. diameter, the connections between the pipes set in the floor to the projector mechanism, should be made in flexibles with securing clips at both ends.

The water flow should be adjusted by using the tap in the feed pipe so the water from the outlet is lukewarm.

An exhaust duct should be fitted to each lamphouse to carry away arc fumes. This exhaust duct should be kept as short as possible. When lamphouses are not coupled to an exhaust system, it is suggested the booth be ventilated by fitting a fan having blades of 130mm. diameter with a 1/5 HP - 2 pole motor.

HINTS ON INSTALLATION

It is recommended that no work should be carried out relating to the installation of the projection equipment until all other work relating to the installation of electrical wiring, water systems and construction work has been completed and the operating chamber is completely clean.

It is recommended that the Chief Projectionist should be present from the time that the installation of the equipment commences.

Ensure that all the required equipment assemblies have been received.

Specification of Dual Equipment (35 mm.)

A standard dual equipment comprises:

- two projectors complete with driving motor - blower - flywheel and optical soundhead oil damper - lens holder - firetraps (Magnetic soundheads if specified);
- two pedestal stand complete with beams for projector and lamphouse with exciter lamp power supply - wiring and tools;
- two upper spool boxes and two lower spool boxes for 1800 mt. spools complete with clutches and take-up units.
- two sets of parts as per specification page 11 Section 1 - 3 Inclusive;
- two lamphouses according to the required type with mirrors;

Additional assemblies for Victoria 8 35mm. 70mm.:

- two wood cabinets containing parts necessary for changing from 35mm. to 70mm. projection (See page 11 Section 4)

The above mentioned material is carefully packed into cases numbered as follows:

- 1 to 8 A Dual Equipment, with open type projector mechanism less lamphouses
- 1 to 11 A Dual Equipment, with open type projector mechanism with lamphouses
- 1 to 12 A Dual Equipment, with enclosed type projector mechanism with lamphouses.

All assemblies and components for No. 1 equipment are clearly marked with a yellow spot (.); those for No.2 equipment are clearly marked with two yellow spots (..); and, if a third equipment is supplied, all assemblies for No. 3 equipment will be marked with three yellow spots (...).

Cases Contents

Cases

- No. 1 - Projector mechanism (.) complete with driving motor, blower, flywheel, oil damper, 2 firetraps, 4 belts, exciter lamp, 1 tin of oil, 2 cans of "S" fluid, nameplate, set of tools for two machines, and spare parts for one equipment, see sheet No. 11
- No. 2 - Projector mechanism (..) complete with driving motor, blower, flywheel, oil damper, 2 firetraps, 4 belts, exciter lamp, 1 tin of oil, 2 cans of "S" fluid, including only spare parts for one equipment, see sheet No. 11.
- No. 3 - Pedestal stand (.) with technical information folder
- No. 4 - Pedestal stand (..)
- No. 5 - Projector beam (.) lamphouse beam, lower take-up, belt cover, exciter lamp supply, elevating screw and support bracket, 70/35 conversion parts cabinet, 11 screws for projector and beam assemblies.
- No. 6 - Projector beam (..) same as above
- No. 7 - Upper and lower spool boxes (.), magnetic soundhead
- No. 8 - Spool boxes (..) same as above
- No. 9 - Lamphouse (.)
- No. 10 - Lamphouse (..)
- No. 11 - Lamphouse mirrors (.) (..)
- No. 12 - Enclosed model only, 2 projector doors with glass panels (.) (..), 2 optical soundhead enclosures, 2 anamorph lens holders, 2 enclosed type magnetic soundheads, 2 lower supports for doors.

Unpacking

Ensure that all cases are kept under cover, and dry, until such a time as unpacking commences. Care must be exercised when opening cases and a nail extractor should be used. Remove all packing material from the cases and make quite sure that smaller packages are all removed. Then when taking out all the parts be careful not to damage the paint. Do not remove any plastic cover from any equipment until you have removed all wood wool packing material.

Standard Tools

Tools (per dual equipment)

- No. 7 Allen Keys (size 2mm. - 3mm. - 4mm. - 5mm. - 6mm. - 8mm. - 10mm.)
- No. 1 Double Head Hexagonal Spanner (14mm. - 22mm.)
- No. 1 Box Hexagonal Spanner (14mm.)
- No. 1 Oil-flow Sight Window Removal Tool
- No. 1 Philips Head Screw Driver No. 1
- No. 2 Standard Screw Drivers
- No. 1 Circlips Pliers
- No. 1 Oiler
- No. 1 Oil Funnel
- No. 1 Swab

Accessories (per equipment)

- No. 1 Tin of Cinematograf Oil (1 Kg)
- No. 1 Tin of "S" fluid (25 grammes)
- No. 1 Tin of "S" fluid (50 grammes)

Spare parts (per equipment)

- No. 6 6mm. diameter Circlips
- No. 6 8mm. diameter Circlips
- No. 6 6x10mm. diameter Roller Washers
- No. 6 6x15mm. diameter Roller Washers
- No. 4 5 Amp Fuses
- No. 1 1 Amp Fuse
- No. 1 1 Timing Belt type 220XL100
- No. 1 Timing Belt type 510L050
- No. 1 35mm. Double Aperture Plate (2.35:1 - 1.66:1)
- No. 1 35mm. Double Aperture Plate (1.37:1 - 2.35:1)
- No. 1 35mm. Double Aperture Plate (1.85:1 - 1.66:1)
- No. 1 16 teeth 35mm. Intermittent Sprocket

Moreover for Victoria 8 - 70/35

Components (per equipment) for changing from 35 to 70 mm. projection.

- No. 1 Wooden Cabinet
- No. 1 70mm. Film Gate
- No. 1 70mm. Gate Plate
- No. 1 70mm. Under-size Aperture Plate (47x20)
- No. 1 70mm. Under-size Aperture Plate (43x16)
- No. 2 35mm. Spool Spindles Spacers
- No. 1 35mm. Corrugated Heat Shield

EQUIPMENT ASSEMBLYNotes

All references to Left or Right are made facing the screen from the operating booth, reference to No. 1 machine is always the left hand projector facing screen.

References quoted in brackets, the number refers to the index and the following letter refers to the part.

The Victoria 8-70/35mm. projectors are always despatched ready for 35mm. projection.

Certain main assemblies are fitted with dowel pins and care should be taken when fitting such components.

All unpainted components are coated with anti-rust oil or grease, which must be removed when installation is being carried out.

All mating surfaces must be thoroughly cleaned before parts are assembled together.

Pedestal Stand (Fig. 4)

Place the Pedestal Stand in the correct running position with the smaller aperture on the right hand side. Remove folder from inside. All electrical connections and water pipes should be so positioned that they rise from the floor immediately beneath the pedestal (see Fig. 3 - A).

Fit the beam elevating screw assembly (4F) with the head of the elevating screw pointing downwards and bolt the bracket to the pedestal stand using the four screws (4 G), use the four lower holes where the projection angle does not exceed 10° negative and the four upper holes when the angle exceeds 10° negative.

The four 60mm x 60mm x 3mm steel plates should be placed under the levelling screw holes in the base.

Projector Base (Fig. 5)

Remove the four screws from the holes (5K). Place the base horizontally over the top of the pedestal stand.

Locate and fix the two pivot pins (5H) and then the elevating slot screws (5F).

Ensure that the special square head screw (5F) on the right hand hole is correctly located with the head inside the slot and locking this from the inside of the stand with the nut provided.

Lamphouse beam (Fig. 6)

Remove the bottom cover to this assembly (6L).

Place the beam onto the projector base at the same time passing the cables from the beam through the hole provided on the projector base and then down into the Pedestal Stand.

Secure this beam with the three long screws provided (6N) on the top side and with the two shortest screws (6M) through the vertical face of the beam.

Projector (Fig. 7 - 8)

Inside the projector mechanism packing case No. 1 will be found a bar (7S) with holes for attaching this bar to the top of the projector mechanism for carrying purposes. This bar is to be fixed cross-wise onto two of the four studs. The bar is to be bolted securely to these studs with the nuts provided before lifting out the projector.

Where the projector being assembled is an enclosed model, mount the exciter lamp cover (11D) and the front cover door support (11F) which have been aligned and correctly located by dowel pins in the projector casing.

Lift the projector onto the projector base.

Take care to pass the exciter lamp cable through the hole provided.

Secure the projector using the four screws (7M) to the base without tightening them down.

Insert the two dowel pins (7N) inside the small bag attached to the projector, then tighten the four mechanism holding studs. Remove cover (8P), lubricate the flywheel spindle using oil hole in casting, clean flywheel (8Q) and fit on to spindle, tighten holding nut on to spring washer (8R).

Check flywheel rotates freely, replace flywheel cover.

Mount the oil damper assembly (7F) using four screws (7G).

Remove plug in projector base, screw oil extension tube (8G) into hole and fit plug (8H) on end of oil tube.

Mount the blower (8S) with 4 screws (8T).

If supplied, mount the anamorphic lens holder support spindle (14F) securing it with the fixing screw (14E).

Mount the motor support casting (8B) onto the projector base using the dowel pins and the screws (8C).

Passing the motor cables through the slot provided into the mechanism beam casting: slacken the adjusting screw (8D) on the motor support.

Fit the belt (8F) between the motor pinion (8E) and the mechanism pulley (8L). Adjust belt tension so that this may be depressed 0.5 cm. in the middle, then lock adjusting screw (8D) and also the upper screw.

Bottom and Top Spool Boxes (Fig.9)

Secure the top spool box assembly (9A) to the studs (7R), fitted on the top of the mechanism assembly and by the dowel pins in the spool box base (9D): Mount the fire trap (7A) with two screws (7B).

Mount the take-up spool box assembly (9M) locking the back-plate (9H) to the projector base with the four screws provided (9N).

The screw (4E) is provided to adjust the spoolbox assembly to a vertical position.

Mount the firetrap (7I) with 2 screws (7Y).

Fit the take-up assembly (9F) with the lubrication hole (9Q) in vertical position.

The spacers (9G) must be placed between the flange of the take-up assembly and the rear of the back plate bracket (on the stand side). These spacers are provided to ensure correct alignment as at the time of factory inspection.

Fit the take-up drive belt (9P) between the projector drive pulley (8N) and take-up pulley.

Adjust the belt so that this may be depressed 1 cm. in the middle, using the slotted holes in the spoolbox back plate to secure correct tension, then re-locking the three screws (9L).

Magnetic Soundhead (Fig.10)

Remove the cover from the left side.

When an enclosed model is being used, locate the front cover plate (11C).

Screw the soundhead assembly to the front part of the mechanism face, correctly locating the dowel pins and fixing with the three screws (10E).

Lubricate flywheel spindle, clean flywheel (10B) and locate on spindle with the shallow cut-away section on the outside, secure with spring washer and nut (10A). Check flywheel assembly rotates freely.

Magnetic Preamplifier (Fig.10)

Mount the Magnetic pre-amplifier (10P) on to the magnetic soundhead left hand side taking care to pass the magnetic soundhead socket through the slot provided. Secure amplifier to soundhead with the 4 screws provided.

The cable should be passed into the stand through the rear big aperture in the projector base and connected to the terminal board (4H) in accordance with the wiring diagram included into case No. 3.

Lamphouse

Refer to the Instructions which vary according to the model supplied.

All lamphouses if supplied with the projector have been correctly aligned and dowelled at the factory.

The cone and the other parts, removed for transit purposes, are to be re-assembled to the lamphouse.

Connecting wires should be passed through the apertures provided in the lamphouse beam.

Secure the lamphouse with the four bolts, inside the bag attached to the projector.

Assemble the mirrors and if Xenon, the bulb according to the instructions provided.

On Cinemeccanica lamphouses the dowser controls the Mascarini switch and when other types of lamphouses are used, a switch should be fitted which remains in the open position when the dowser is closed. Cables should be connected in accordance with wiring diagram provided in Case No. 3.

Electrical Connections

The exciter lamp, framing lamp, safety device and change-over controls are supplied from a compact unit fitted inside the pedestal.

Fig. 12 (1) is supplied as a standard unit but alternative assemblies No.2-3-4 and item 5 (Smoothing Choke) can be supplied on request.

All cables supplied are made up into cable forms with the terminal ends marked with numbers corresponding to the numbers on the terminal boards and should be connected in accordance with the wiring diagrams contained into Case N.3. The cable with the flexible lead coming from the changeover control should be passed through the big aperture in the base. Before switching on, check that all adjustable voltage tappings on the equipment have been set correctly to correspond to the input main voltage.

Water cooling connections (Fig. 17)

The water outlet (17D) must be free running, that is water should run without pressure and the outlet must be visible, if possible. Water pipes for flow and return fetched underneath the projector stand must be passed through the big hole on the projector base (3A).

Carefully mount the connectors and rubber plastic hoses (17B) between the incoming water pipes and the connectors on the projector shutter housing.

Check connections at a flow rate higher than the normal operational requirement, afterwards, reducing the flow of water to a minimum required to obtain efficient cooling without causing condensation.

Covers

Fit the belts cover on the projector (5L) using the locking screw (5M). Fit the pedestal stand cover (4B). Replace the lamphouse beam cover (6L), the preamplifier cover and the magnetic soundhead cover.

Enclosed Equipment (Fig. 11)

Mount the top frame extensions (11A-B) and the front extension (11 E).

Line up the edges of the supplementary frame extension castings and the door so that they are set to the main mechanism body and tighten all the screws.

Second Equipment

Carry out the same sequence of operation for the assembly of the second equipment (..).

PREPARING PROJECTORS FOR OPERATION

Remove all protecting grease by using a small brush and a cloth dipped in Carbon-tetrachloride.

Ensure that all sprocket teeth are clean. Ensure the soundhead objective lens assembly is kept clean.

Unscrew the filler cap mounted at the top of the rear cover and using the funnel provided pour in sufficient "Cinematograf" oil until the level indicated by the red pointer in the lower window on the operating side is reached (run the projector for a short while and add sufficient oil until the level again reaches the centre red point).

Remove the damper pots from the oil damper assemblies on both the magnetic (23M) and optical (23N) and fill with the special "S" fluid supplied, up to 1 cm. from the rim of the pot which must then be replaced with care.

Insert the pre-focussed exciter lamp (22A) into the holder. Position this so that the protrusion at the end of the vertical spring (22B) attached to the exciter lamp support bracket locates into the dimple placed in the exciter lamp barrel.

The exciter lamp control switch (6G) is on the lamphouse beam. Check on the ammeter provided (6C) and adjust using the rheostat (6E) the exciter lamp current in order that the maximum current is:

3,5 Amps for photojunction (T)

5 Amps for photocell (V).

Check that there are no leaks in the water circulating system. Check that the Mascarini switch is lined up with the white indicator.

Check that all switches are "OFF".

Projector running checks

Close master switch on main control panel.

Use the inching knob on the motor to check that mechanism is free running.

Switch the projector on using the motor start switch (6F) retaining this in the intermediate position () for a short while before going over with the switch control to the red dot. Check that the projector is running in the right direction. If running the wrong way, change over two of the 3 phase connections to the motor.

Check that the lubrication system is working correctly. The upper oil sight window must fill and remain filled the whole time the projector is running. Check that the motor drive belt and the take-up belt are running correctly on the centre of the pulleys. Check that the blower (17A) and lamphouse exhauster rotation is correct.

Check the operation of both the safety dowsers and Mascarini switches.

Carbon or Xenon Lamphouses

Check the polarity of the supply to either the Xenon bulb or Carbon Arc (on the Xenon bulb, the positive connection must be at the top and on a Carbon Arc, to the front Carbon i.e. the one furthest from the mirror).

The motor generator or the rectifier must be set, whilst testing is being carried out, to provide a medium current according to the bulb or carbons used.

Close the switch (6A) to start either the motor generator or the rectifier. The pilot lamp (6B) on the stand beam should light. Strike and switch off the Xenon or Carbon Arc a few times to establish that a reliable performance is being obtained.

Lens

Concentric lens adaptors must be used if it is desired to employ lenses having a barrel diameter of 52.5mm. in the 62.5mm. apertures. Should it be required to use the 70.6mm. diameter aperture for normal, wide screen or optical CinemaScope film then an eccentric lens sleeve will have to be employed in this position.

Three lens holder (turret) (Fig.13)

Two of the lens holders have a diameter of 62.5mm. and are centered for normal, wide screen and optical CinemaScope projection. The remaining lens holder has a diameter of 70.6mm. and is centered for 70mm. or CinemaScope magnetic films. Lenses are located by means of screws (13A) visible through the hole provided (13B) on the outside of the rotating assembly. To change over from one lens to another press the lever (13C) and rotate the assembly in the required direction until relocked by lever (13C). To open the turret assembly operate lever (13D) and push forward. To shut turret, just turn this towards the gate and make sure that this locks into position.

Single lens holder (Fig. 14)

This lens holder is supplied with an eccentric lens sleeve reducing the 5" diameter mount to 4" (101.6mm.). This sleeve can be rotated in the mount and locked in position by means of the screw (14A).

For normal, wide screen and optical CinemaScope films, release lock screw (14A), rotate sleeve using stud (14B) in clockwise direction to stop (14J).

This will place sleeve in correct position as indicated by engraving "35mm. Optic" on lens mount.

For magnetic CinemaScope and 70mm. films, rotate sleeve anti-clockwise using stud (14B) until white line (14K) lines up with white spot on right hand side of stop (14J). Sleeve will be correctly placed in position as indicated by "70-35 MAG." engraving on lens mount.

Tighten screw (14A).

Lenses of various diameters and types having a diameter lower than 4" may be used by employing lens sleeves (14D). Upon request, we are able to supply sleeves reducing from 4"/70.6mm. - from 4"/62.5mm. - from 4"/52.5mm.

These sleeves are provided with two nylon locking screws (14L) to locate the lens in the sleeve.

On each sleeve a line is marked. This should always be aligned with the stop ring line (14Q).

To ensure that the lens and its sleeve can be removed from the mount and returned to the same correct position, the notch in the stop ring (14C) must always be engaged with the stud (14B).

To set the lens in a near focus position release lock screw (14M), slide the lens along the guide (14N) until approximate focus is secured, lock screw (14M) and carry out final focus by using control knob (14P).

Anamorph Lens Holder

Triple lens holder (Turret) (Fig. 13)

Insert the anamorphic lens into ring (13G) and lock with screw (13F).

By releasing holding screw (14H) the anamorphic lens holder (13G) can be adjusted backwards and forwards.

Single Lens Holder (Fig. 14)

Insert the anamorphic lens into the holding ring (14T) and lock with screw (14S).

Turn the anamorphic lens holder into the projection position, depress lever (14R) and pull towards the main projection lens holder.

The anamorphic lens holder can be adjusted along the length of the shaft (14F) by loosening the locating collars secured by screws (14G and 14H).

To centre the anamorphic lens to the centre of the main projection lens adjust the screw (14V).

Aperture plates, pressure pads and gate frame (Fig.15)

The Victoria 8-70/35 projection equipment is always delivered ready for projection on 35mm.

The following instructions should be followed to change from 70mm. to 35mm. projection.

35mm. Projection

Insert the corrugated shield (15M) with the small hole towards the operating side. Rest this on the bottom of the aperture and locate the dowel pin into the hole in the shield.

Insert the aperture plate guide (15N) with the small hole towards the non-operating side of the mechanism. Locate this on the dowel pin provided.

Insert into the aperture plate guide the ratio of the aperture plate required (15P). The mask plate is retained by lever (15B) which must be raised to insert or withdraw the mask plate according to the aperture to be used.

Insert the 35mm. gate plate (15Q) in the lateral guides on the gate frame (sliding it down between the guides until it rests upon the two lower locating screws at the bottom of the lateral guides) and lock the gate plate with screw (15A). Care must be taken to ensure that the bottom of the gate plate does not come into contact with the teeth on the intermittent sprocket. Under any circumstances, no exchange of gate components should ever be carried out with the projector running.

Before fitting the gate frame, check that the pressure pads are clean and if it is necessary to clean them thoroughly remove them from the frames.

This may be carried out by removing the cover (16C), then unscrew but do not remove screw (16H), push the pressure pads upwards and remove from the frame.

To fit the gate frame, turn the gate control knob (15D) to the open position by turning on the right, locate gate frame on to the guides, push down until located on the holding pins. Check that frame is correctly located, then close gate by pressing lever (15C).

Check that all roller assemblies are in the 35mm. projection position (see notes Fig. 24), i. e. red indicator at the top. Set the 35mm. spool spindle spacers over the top and bottom spindles.

70mm. Projection

To change to 70mm. remove the 35mm. gate plate, the mask plate, the mask plate guide (lifting the ends slightly to free from the locating dowel pin), the corrugated shield.

Insert the 70mm. mask plate which again is located by the lever (15B).

Mount the 70mm. gate plate and the 70mm. gate frame (See note under 35mm.).

Check that all roller cradles are in the 70mm. film projection position (see Fig. 24), i.e. yellow indicator at the top.

Remove the spool spindle spacers.

Projector Alignment

After the lamphouse has been fitted in accordance with the instructions after the Arc or Xenon bulb strike test, after the exhaustor or the exhausting system operation control, pass on to the projectors alignment.

Select the shortest focal length lens to be used. Run the Carbon Arc or Xenon bulb lamp at a low amperage with projector running. Care should be taken not to damage the lens by too long an exposure to the heat either using a heat screen or opening and shutting the lamphouse dowsor from time to time whilst these adjustments are being made.

With projector running lift the safety shutter (18C) pressing control knob (18L).

Make a first adjustment.

The light path should be centered through the port hole. Centre the projected aperture horizontally on to the screen. For vertical adjustment use the elevating screw (4F) to position the projected aperture on to the screen, lock the 4 screws on the beam (5F-H). The four levelling screws in the stand box (4N) may be used to square up the projected image on to the screen.

Carry out adjustments to obtain maximum light and even distribution on the screen (refer to lamphouse instructions).

Lacing Test Film

Check that the projector is set for 35mm. film projection.

The installation Engineer should ensure that the projectionist running the equipment is fully informed concerning the method of adjustments (see page 24).

Check that the cradle roller assemblies are all in the correct position (See Fig. 23). Lace film as directed (Fig.23)

It is suggested that the projectionist should carry out tests with the various types of films to become familiar with the different systems.

Check that the take-off and the take-up spool spindle clutches are working correctly.

Safety Device (Mascarini) (Fig. 18)

The film loop (18G) situated just above the film gate and the intermediate sprocket will operate the safety device in the following cases:

A) Film breaking in the gate

The film jams in the gate and causes a loop to form underneath the Mascarini lever (18F), lifting the lever, which in turn operates the Mascarini switch (6D) by means of a built-in relay closing the projector down.

B) Incorrect Film speed

A centrifugal governor operates the rotating disc (18E) releasing the Mascarini safety lever (18F) and opening the switch only when projector reaches the correct film speed.

The Mascarini lever (18F) is coupled to connecting lever (18H) so when the control knob (18L) is operated, the lever will engage and hold the safety shutter (18C).

C) If the lamphouse dowsler is opened when the projector is stationary

The switch turns off the safety device circuit.

The device is so connected that it will switch off the supply to the motor and to the lamphouse and can also be arranged and connected so that the auditorium lights and other similar types of controls can be fetched into operation.

The device is operational when the control handle covers the white silhouette.

Framing

Framing lamp is controlled by switch (6H). The horizontal slot above the aperture (15R) is illuminated by framing lamp (15T) to allow the correct location of the picture frame over the aperture. To ensure correct framing of film in the picture gate, rotate the motor using the inching knob on the motor shaft until the intermittent sprocket is in the stop position. Film may then be placed locating correctly as described over the aperture around the intermittent sprocket, closing the sprocket roller cradle (15H). The red indicator spot on the masking knob (7T) must always be inclined towards the operator.

The intermittent unit assembly must always be located with the two red spots (15L) in line.

Undersize Mask Plate Apertures

Undersize mask apertures are supplied for 35mm. ratios so that corrections can be made after the projectors have been correctly set in position and the position of the screen finalised, curtains arranged, which should all be carried out using test film.

With the film correctly focussed on the screen (it is the film which is focussed and not the outline of the mask aperture), arrangements can be made to file the mask plates to compensate for any keystoneing of the image which may occur due to projection angles on the vertical side lines of the mask aperture and any curvature distortion which may occur on the horizontal lines due to the use of curved screens.

Careful adjustment of the mask plates by filing will enable a completely uniform frame to be projected.

Frame dimensions for different ratios are as follows:

Aspect	Ratio	Film		Mask Plates	
		width	height	width	height
Normal	1.37:1	20.96	15.24	20.5	14.8
Wide screen	1.66:1	20.96	12.62	20.5	12.3
	1.75:1	20.96	12	20.5	11.7
	1.85:1	20.96	11.33	20.5	11
CinemaScope	2.35:1	21.37	18.16	20.8	17.5
	2.55:1	23.16	18.16	22.5	17.5
70mm. Film	2.2:1	48.56	22	47	20
				43	16

Change-over Control (Fig. 18 - 19 - 20)

To change over picture and sound from one machine to the other, lift the safety dowser (19B) which will operate two micro-switches. One micro-switch (19A) will change over the picture and cause the safety dowser to drop on the outgoing projector, the other (19C) will change over the sound by operating the relay fitted in the change over box.

For projectors supplied with change-over control (type ZIPPER) (Fig. 20) to change over from one machine to the other, lift the safety dowser (19B) and push the button (20H) which will operate the Solenoid (20F), lift the safety dowser (20G) and operate the sound micro-switch (20E) fitted in the change-over box.

The external control knobs are only used in case of an emergency. After making a changeover, check that picture and sound are satisfactory, close lamphouse dowser on outgoing projector and switch off.

ADJUSTMENTS

Adjustments to be carried out are the same both for 35mm and 70mm projections.

Pads Pressure (Fig. 16)

All pressure applied to the film should be kept to an absolute minimum and should not exceed that necessary to keep a steady picture.

For 35mm Film

On the 35mm gate, screw (16D) adjusts the pressure of the four gate runners onto the film. Turning this screw c.w. will increase pressure. The engraved numbers are only used as references.

For 70mm Film

The 70mm gate knurled nuts (16G-H) adjust the spring tension applied to the pressure pads. The top knurled nut (16G) adjusts the runners controlling the film entering the gate.

Optical and Magnetic Damper (Fig. 23)

Whilst running projector check loops are as for Diagrams shown (Fig. 23).

Optical

Rotate screw (22R) until the lower edge of the damper cone (23P) is in line with the top of the gauge (23 I).

Magnetic

Adjust the control knob (23B) until the axis of the roller (23A) is in line with the red spot (23C).

Sound Synchronisation35mm Optical Film

The synchronisation distance between picture and sound is 20 frames. Sound preceding picture.

35mm Magnetic Film

The picture to sound synchronisation distance is 28 frames. Sound following picture.

70mm Film

The picture to sound synchronisation distance is 24 frames. Sound following picture.

The sound synchronisation roller (10F) on the magnetic sound head permits the synchronisation distance to be adjusted. Loosening the screw the roller arm assembly can be rotated to shorten or lengthen the film path. The film can be laced also as marked on the soundhead cover to secure standard synchronisation.

Pressure rollers on optical and magnetic soundheads

Check whether the film travels between the flanges of the sound drum. The pressure lay-on roller is on an articulated mount which allows it to be self-aligning to the face of the drum. Make sure that the pressure exerted does not bias the film towards either of the flanges on the sound drum.

Optical Soundhead

Release screw (7D) of the control knob (7E), rotate the knob in the required direction bearing in mind that when turned anti-clockwise tension will increase.

Magnetic Soundhead

Release screw (10H) of control knob (10L), rotate the knob in the required direction bearing in mind that when turned anti-clockwise tension will increase.

Roller Arm Assemblies

Make sure that a film joint can pass round the sprocket freely. To adjust the position of the rollers in relation to the sprockets release the lock nut (7P) and rotate screw (7Q) in the required direction locking screw again after completing adjustment.

Intermittent sprocket roller arm assembly

To adjust this assembly, release screw (15F) and rotate the control knob (15G) in the required direction. Rotation anti-clockwise will increase the tension.

To adjust clearance between the rollers and the sprocket, release lock nut (15 I) and rotate screw (15 Y) in the required direction, relocking the screw upon completion of the adjustment.

Optical soundhead Objective Lens (Fig.22)

The line (22H) should be in line with the centre of the oval hole of the soundhead bracket. Lock with screw (22 L).

To adjust the light beam use a constant frequency test loop (Example an A9Kc SMPTE track).

To focus rotate the knurled mount (22 F) secured with screw (22G).

To carry out the horizontal adjustment of the slit rotate the objective lens assembly with special key locating in the slot (22E), until maximum signal level is obtained, then lock screw (22L).

For correct centering use a film loop of ABZT (Buzz track) and adjust using knurled screw (22C).

To adjust the scanning of the soundtrack rotate the knurled nut (22N) and lock by screw (22M).

Top Clutch

The top clutch must be adjusted so that a spool will not over-run. Should the film, in passing over the top sprocket, make a noise, this indicates that the clutch is too tight and could ultimately lead to damage the perforations. Adjustment of the clutch may be carried out by turning the control knob (9B), rotation clockwise will increase the tension applied to the clutch assembly.

Bottom Clutch

Should the take-up be noisy in operation, this indicates that the tension on the bottom clutch is excessive and film perforation damage could be caused. However, the take-up clutch tension must not be too slack. The clutch can be adjusted as required, rotating the control knob (9E). Tension on the clutch is increased by rotating this knob in a clockwise direction.

Focussing

(Please refer to page 18 concerning Lenses)

Framing

(Please refer to page 22 concerning Framing)

Lamphouses

(Please refer to Lamphouse Instructions).

PROJECTOR RUNNING CHECKS

It is essential that the people responsible for carrying out the installation make quite sure that the projectionist is completely informed about all the various controls and adjustments which are necessary to keep the equipment operating in an efficient manner. In this respect we are setting out herewith a summary of special points requiring attention.

Film Threading

Take care not to lace an optical film on a magnetic soundhead or alternatively a magnetic film through the optical soundhead.

35mm. Optical Film

Lace the film "35mm. OPTIC" (as shown in Fig. 23)

35mm. Magnetic Film

Lace the film "35mm. MAGNETIC" (as shown in Fig.23)

70mm. Magnetic Film

Thread the film "70mm. MAGNETIC (as shown in Fig.23).

Mount the spool in the top spool box and fold the shaft hinged tip.

Pull out the leader and thread this through the top firetrap assembly (7C). Proceed with the lacing of the film through the projector opening and shutting the roller arm assemblies as they come starting from the top sprocket.

Check that the loop is the correct size between the intermediate sprocket and the gate entry.

When lacing the film through the magnetic soundhead, the film must not be put under tension by depressing the damper roller (23A).

The Loop (23K) between the last tooth of the intermediate sprocket and the entrance to the gate plate must be 17 perforations long for 35mm. film and 13 perforations long for 70mm. film.

Too big a loop will cause noisy running and too small a loop may cause film damage.

The loop (23H) between the last tooth of the intermittent sprocket and the idler roller axis must be 15 perforations long for 35mm. and 11 perforations for 70mm. film.

The film must be laced through the lower firetrap (17H).

Insert the bottom spool, fold the shaft hinged tip and wind the film round the hub using the slots provided or by means of adhesive tape should slots not be provided, then shut both top and bottom spool box doors.

Take up all slack between the lower sprocket and the spool and between the top spool and the top sprocket+.
Check that all roller assemblies are closed and are set for either 35mm. or 70mm. film with the same colour upwards.
Rotate the projector employing the inching knob on the motor.
To start projection take the following action:

Strike the Xenon Lamp or Arc (1 - 2 minutes)
Switch on the projector with the starter (6F) slowly rotating the lever and remaining in the mid-position () for at least one second whilst the projector gathers speed and before going into the run position (red point).
Open the lamphouse dowsers.
Watch the film for start signal and open the safety dowsers (18C) by pushing control knob (18L) and holding for at least half a second.
In case of projectors provided with picture change-over (Fig.20) lift the safety dowsers (18C) before the film start signal and at the signal push the control knob (20H).

Instructions for changing from 35mm. projection to 70mm. are given on page 24.

MAINTENANCE

After projecting one film spool

Thoroughly clean the pressure pads and the gate plate.

Daily Attention

With the projector mechanism stationary, clean the sprocket teeth, taking care not to damage the teeth. A medium stiff tooth-brush is ideal for this purpose. Clean the magnetic soundhead. Check that all rollers rotate freely and are free from deposit on the film contact surfaces. Should it prove necessary to remove rollers for the purpose of cleaning spindles and the bore of the rollers, remove, clean and replace one roller at a time. Clean both the sound-drums on the magnetic and optical soundheads.

Once a week

Clean the entire projector and the spool boxes with a soft clean cloth.

Remove and clean the two firetrap rollers retained with screws.

When reassembling, replace the stop plate (7C-H) back in the correct position.

Clean the air blower filter.

Once a month

Check drive and take-up belt tension, readjust if these have stretched.

Clean safety dowser (18C) to maintain reflective surface in good condition.

L U B R I C A T I O N

FIG.21

Drain the oil and replace it after the first running week and the first month running. Afterwards, replace the oil every six months.

To drain the oil from the sump remove the oil plug (8H) on the end of the extension tube (8G).

Check the oil level each day through the lower sight window bearing in mind this level must be maintained at the red indicator spot with the projector running.

Check that the oil pump is working correctly through the top sight window. This window should be completely filled with oil with projector running.

Every six months, when changing oil, clean the oil filter and the magnetic filter of the top sight window.

For this purpose, remove the knurled cap (21B) using the special spanner supplied (21A). Remove the magnet and clean it. Remove the gauze filter and clean with petrol (gauze only). When reassembling take care not to damage the sealing gaskets.

Once a month, place a few drops of oil into the holes (marked red) for the top clutch bearing (9R) and the bottom take-up (9Q), in the optical soundhead lubrication oil cap (18D) and on the lens mount control screws, on the large 70mm. firetrap roller, the projector motor (8A), and the blower motor (8V), on the gate assembly guide rods (15V).

DEFECTS - CAUSES

Projector motor does not start

- Master switch open
- Safety device open
- Motor starter contacts are dirty or defective
- Starter fuses blown or resistors burnt out

Film breakage or damage

- Upper clutch to be adjusted
- Bottom clutch to be adjusted
- Entrance and output gate loops too short
- Incorrect film threading
- Locked rollers and roller arm assemblies without clearance
- Defective or incorrectly aligned film sprockets
- Unsuitable spool hub

Lack of sound synchronisation

- Incorrect film threading
- Film lacing on the magnetic soundhead to be adjusted with the 2 roller arm assemblies

Sound flutter

- Varying film speed
- Oil dampers out of adjustment or lacking oil
- Soundhead flywheel does not turn regularly
- Pressure pads to be checked
- Optical soundhead objective lens to be cleaned

Noisy film operation

- Gate entry and lower loop to be corrected
- Gate pressure plates to be adjusted or to be cleaned

Noisy projector operation

- Lubrication to be checked
- Slack screws on the covers
- Belt misaligned

Safety device does not close

- Lamphouse dowsel left open
- Pieces of film have jammed the lever

REPLACEMENT OF THE INTERMITTENT UNIT (Fig.25)

In the unlikely event that it should prove necessary to replace an Intermittent Unit, the instructions set out herewith, if followed closely, will enable an exchange to be carried out quickly and efficiently.

First, remove the Gate Bracket and the Gate Plate. Turn the Projector slowly by hand until the Intermittent Sprocket is in the 'locked' position and then remove it from the spindle. Remove the Intermittent Sprocket Roller Arm Assembly (25M), Steel Circlip for Collar (25L), the Roller Arm Stop Collar (25G), Clutch Spring Bush (25H), Clutch Spring and Plate (25F) the Screw Cover (25D) and the Holding Screw (25E) with washer.

If fitted, remove the Magnetic Preamplifier which in turn will allow the rear Main Cover of the Projector to be removed complete with Blower Motor Assembly.

Slacken off the Screw Locating the Racking Shaft (25B) and draw this forward until the end of the Shaft disengages with the rear Bearing inside the Projector housing. When carrying out this operation note the position of the red mark dot (25A).

Rotate the Intermittent Unit until this is clear of the Gear Train, then withdraw from the mechanism body.

The replacement Intermittent Unit must first be set so that the Intermittent Sprocket Spindle is in the "locked" position and should then be inserted into the main casting turned until such time as the drive gear is meshed with the driving gear. The unit may then be locked with Screw (25E). Re-set the Framing Control Spindle, then the Clutch Disc (25F) ensuring that the red spot on the disc and the red spot on the Main Casting are in line. Re-place the spring and the spring bush (25H) which should be screwed up tightly then unscrewed 1/4 of a turn. Without running the projector, check the Framing Movement, operating this to the extreme Full Rack Top Position and the Extreme Full Rack Bottom Position, rotating the mechanism by using the Inching Knob on the Motor whilst this Rack check is being carried out to ensure that the mechanism rotates freely, irrespective of the position of the Racking Movement.

Re-assemble the screw cap (25D) the Roller Arm Assembly Spring, the stop Collar with Ring, the Roller Arm Assembly (25M), re-adjusting the tension on the roller arm. Replace the Intermittent Sprocket. Locate the Key Washer in the groove cut in the Sprocket Spindle and lock with the Fixing Screw.

Replace the rear Cover of the Projector and if fitted the Magnetic Preamplifier Assembly.

Should the Shutter be out of Phase, rotate the Intermittent Sprocket until the point is reached when the movement of the film is about to commence. Slacken the Shutter Holding Screws (18P) and move the Shutter Blade round to a position to correspond with the Bottom line of the Aperture (18N) and lock the screws.

The Shutter rotates clockwise when viewed from the Lamphouse position. When running a test film, (for instance C.T.C.) should travel "ghost" appear on the top of the picture, move the shutter forward in a clock-wise direction. If Shutter travel "ghost" appears on the bottom, move the Shutter anti-clockwise.

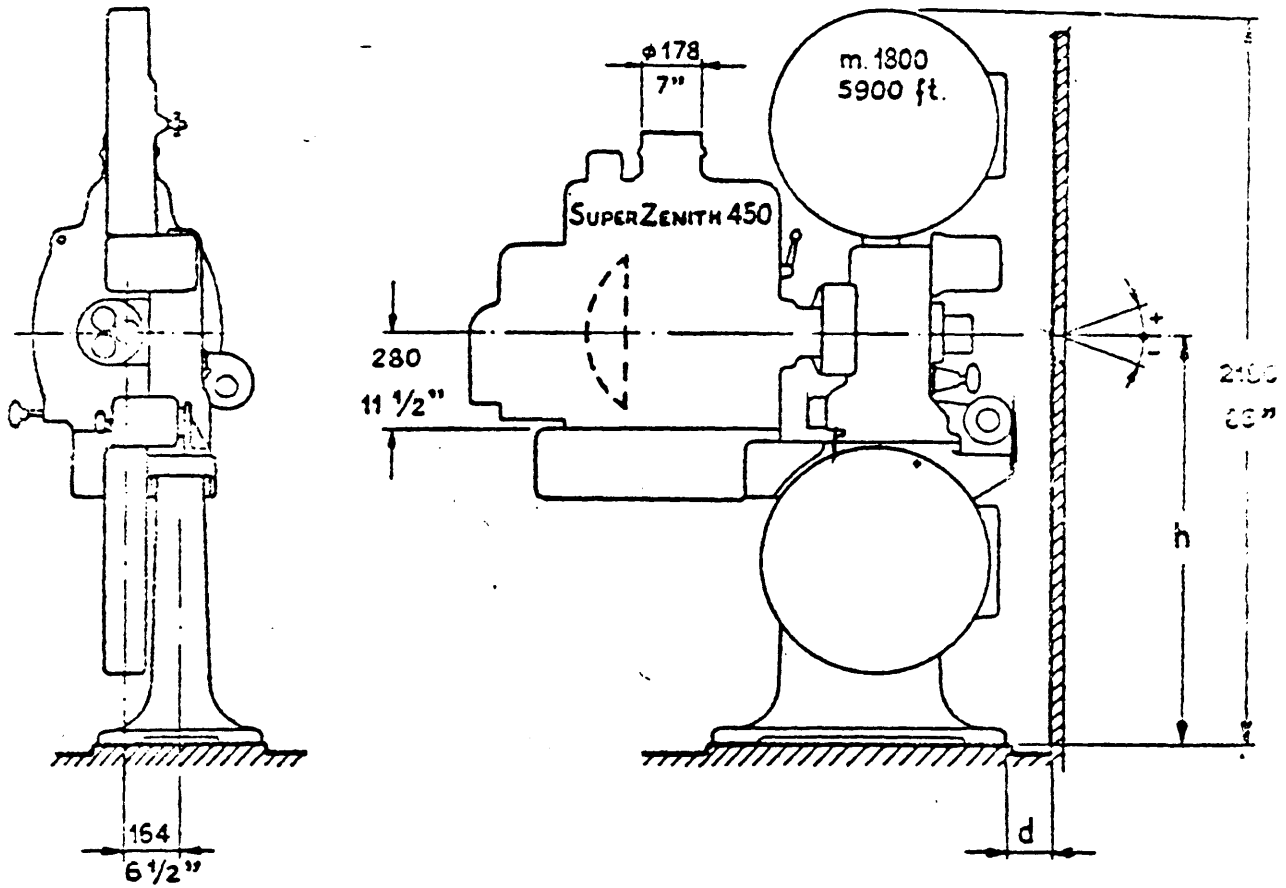

angolo angle	d	h	d	h
	mm		inches	
+ 5°	115	1235	4 1/2	48 3/4
+ 4°	115	1225	4 1/2	48 1/2
+ 2°	115	1215	4 1/2	47 3/4
0°	115	1200	4 1/2	47 1/4
- 2°	155	1185	6	46 3/4
- 4°	195	1170	7 3/4	46
- 6°	235	1150	9 1/4	45 1/4
- 8°	270	1130	10 1/2	44 1/2
- 10°	310	1105	12 1/4	43 1/2
- 12°	350	1080	14	42 1/2
- 14°	393	1050	15	41 1/2
- 16°	420	1020	16 1/2	40
- 18°	455	985	18	38 3/4

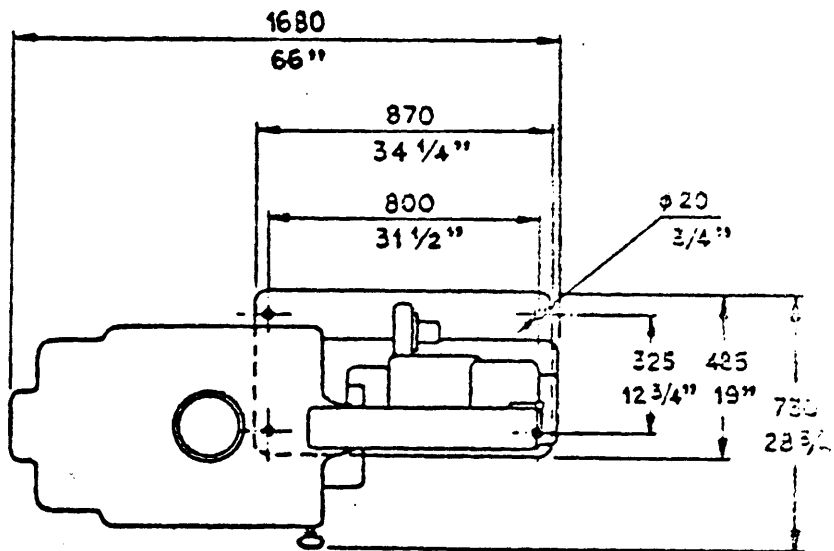
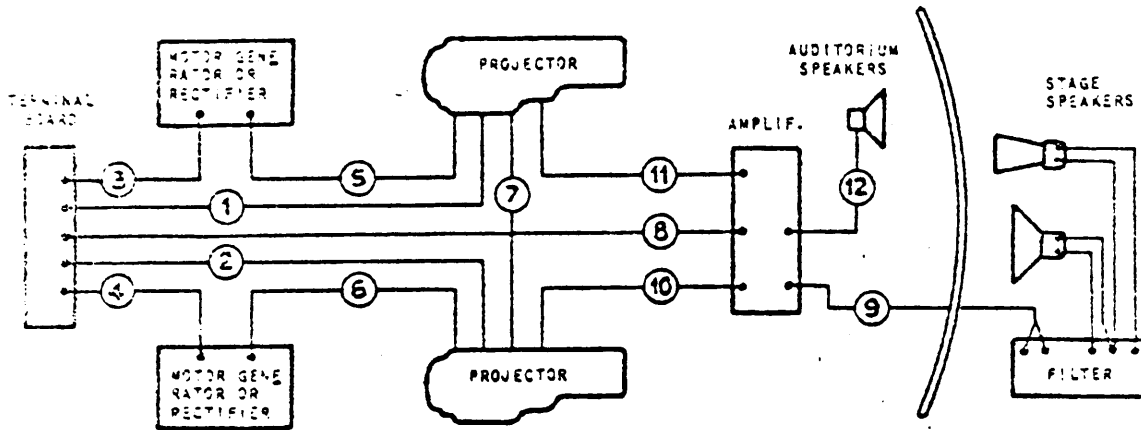

FIG. 1



CONDUIT	CABLES NO	WIRE GAUGE AND DIAM.	D U T Y		F E E D I N G
			AMP. MAX.	VOLTS	
1 - 2	3	3/.036	3	Line P.	Projector motor
	2	3/.036	3	Line P.	Contactor (only for motor generators)
	2	7/.029			Mascarini device house lights
	2	3/.036	0.5	Line L.	Lighting
	1	3/.036			Ground connection
3 - 4	3	7/.044	20	Line P.	Motor generator or rectifier
	1	7/.044			Ground connection
5 - 6	2	19/.064	120	90	Lamphouse power supply
	2	7/.029	8	90	Field winding or starter
7	4	3/.036	6	140	Picture change-over
8	2	3/.036	3	Line P.	Amplifier line
	1	3/.036			Ground connection
9	2	7/.029			Stage speakers line
10 - 11	4	3/.036			Power supply
	1	22/.0676		Shielded	Audio signal line trans. preamplifier
12	2	7/.029			Auditorium speakers

FIG. 2

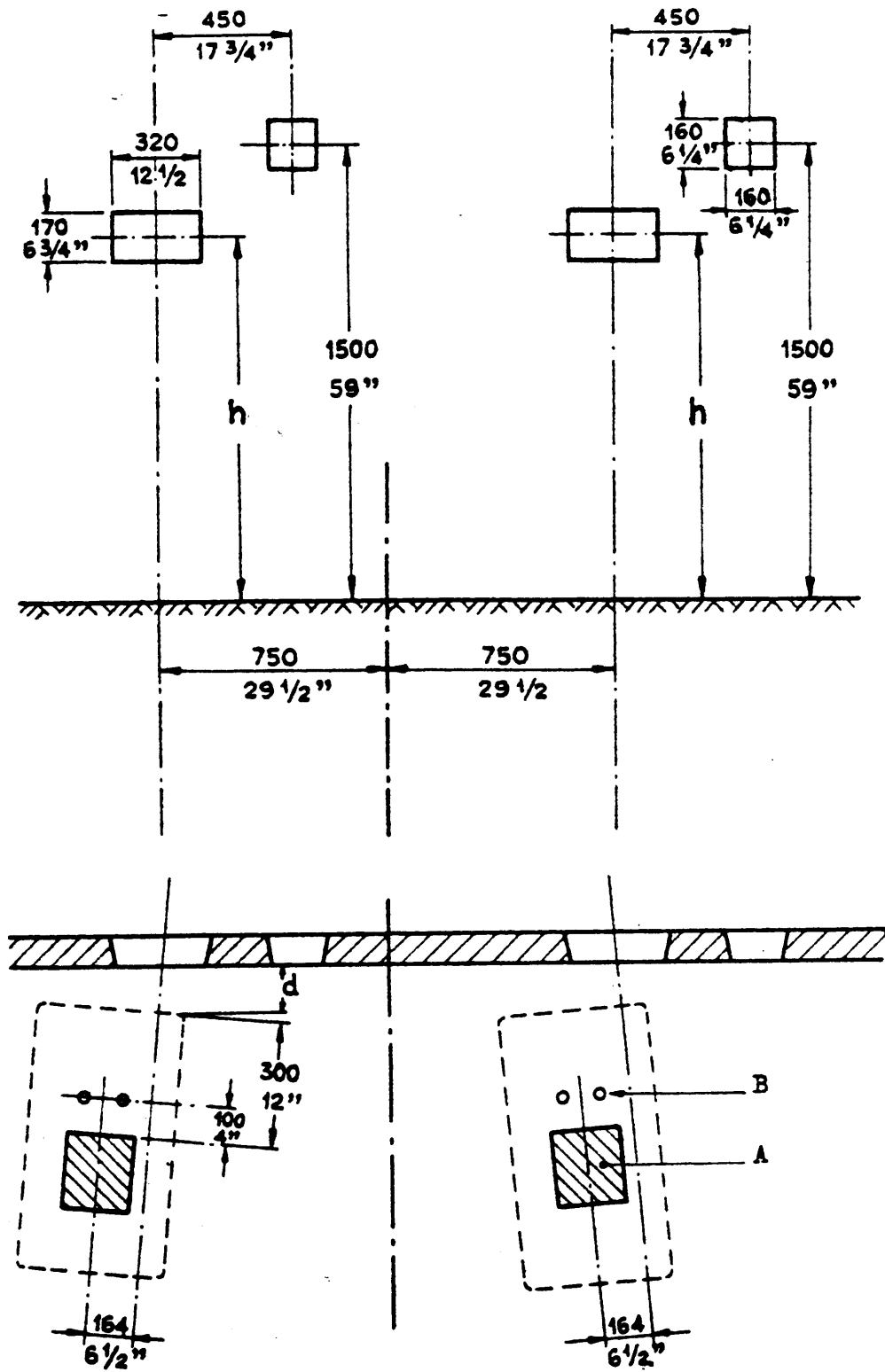

FIG. 3

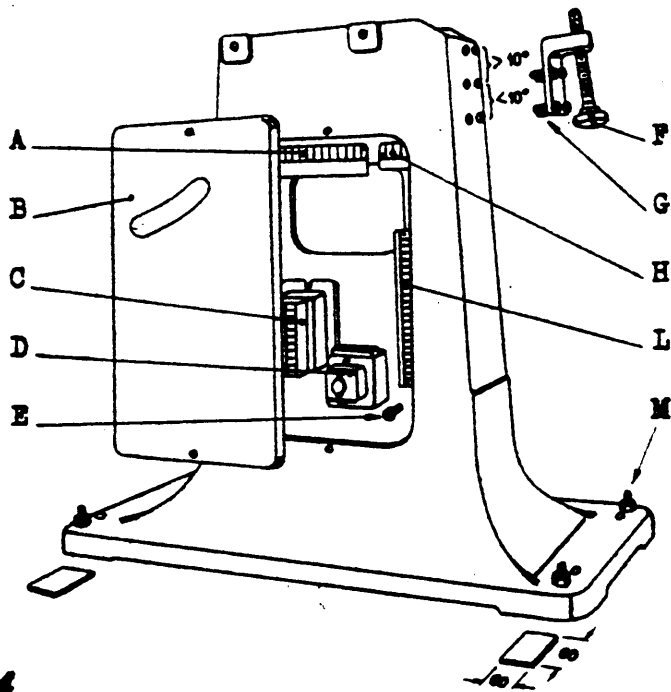

FIG. 4

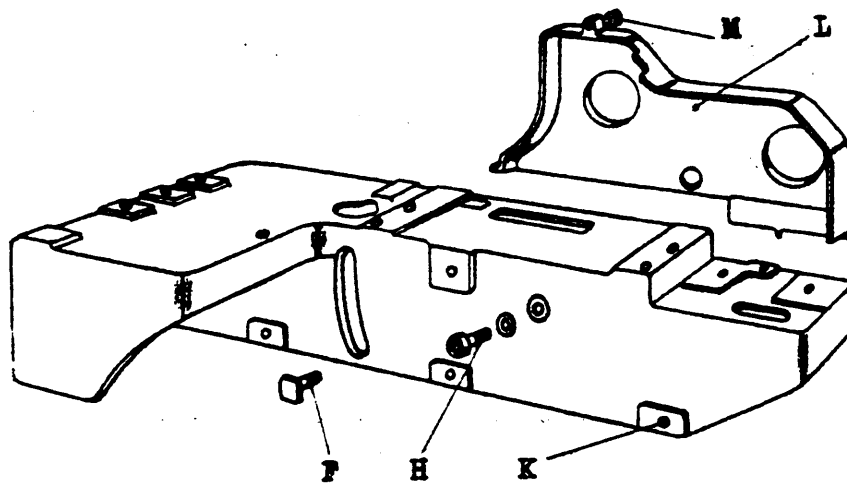

FIG. 5

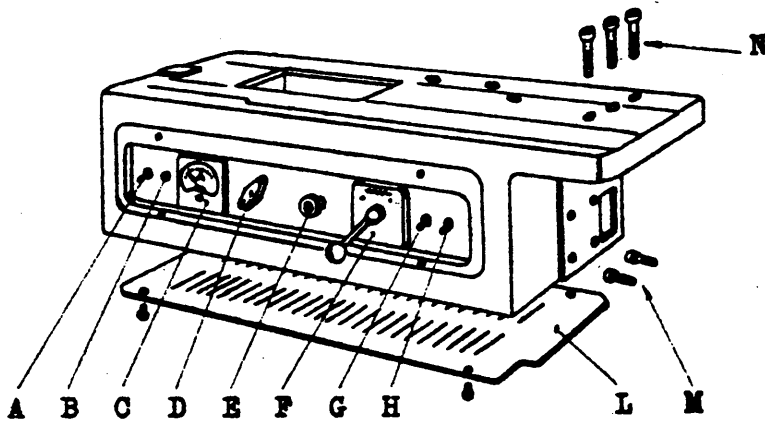

FIG. 6

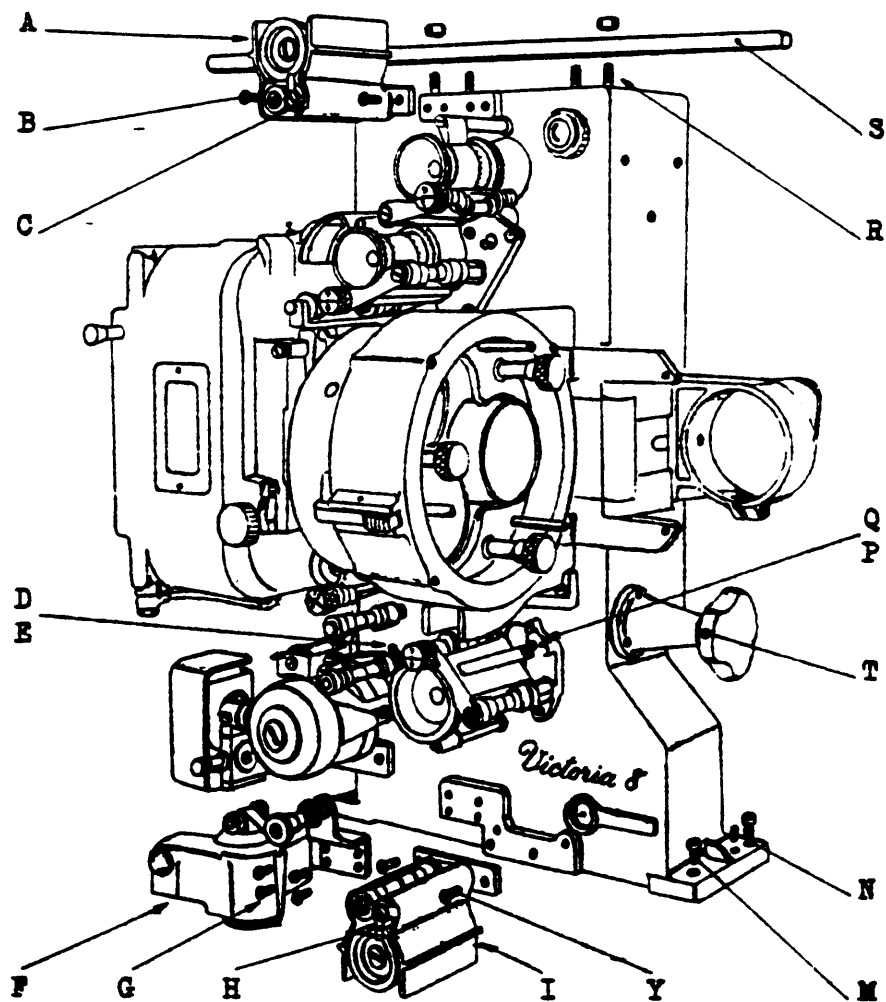

FIG. 7

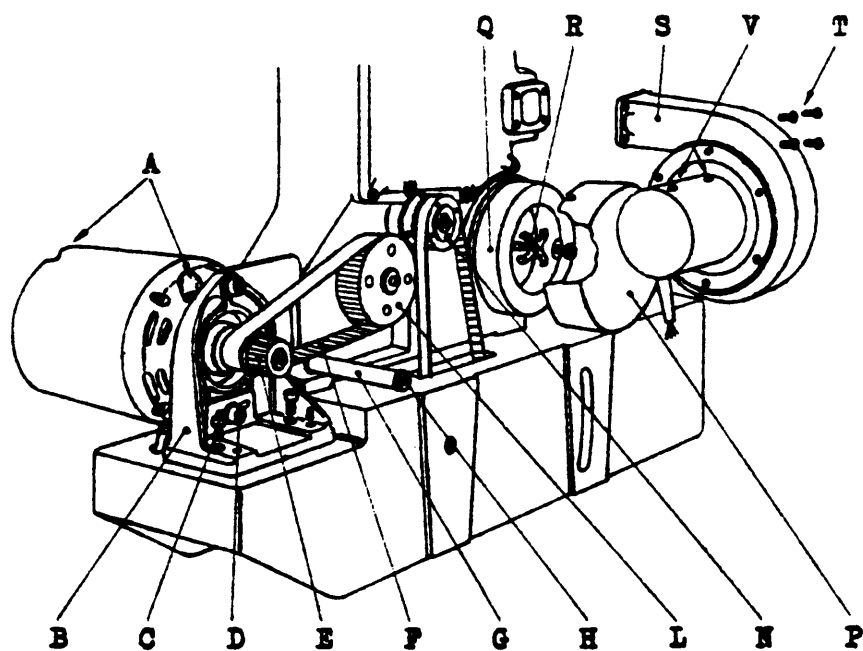

FIG. 8

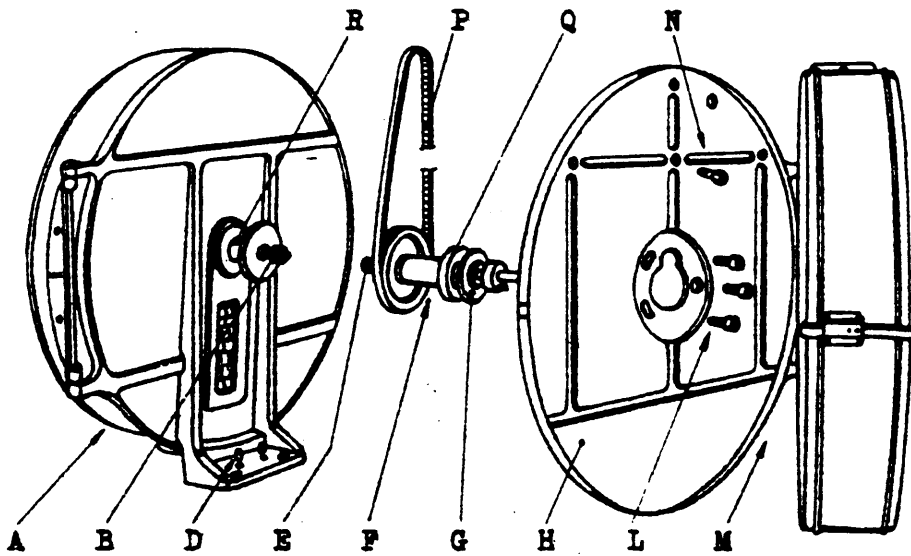

FIG. 9

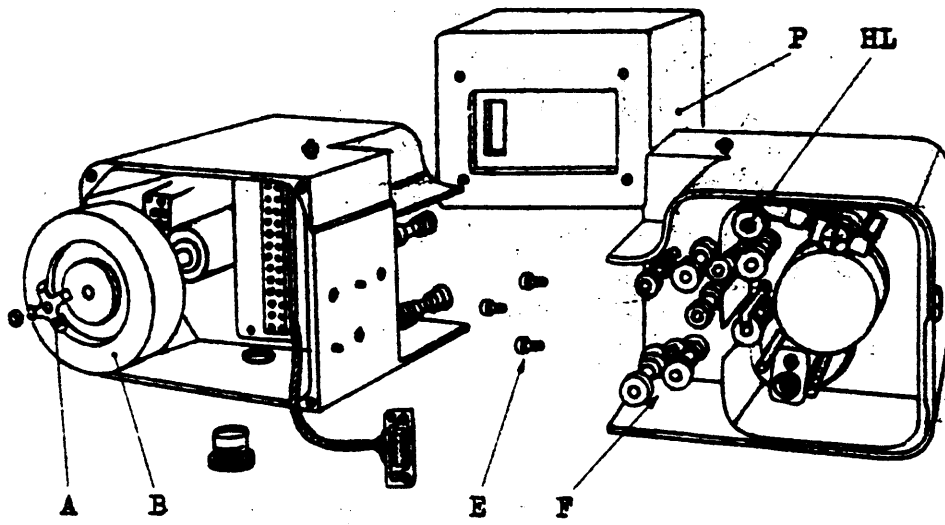

FIG. 10

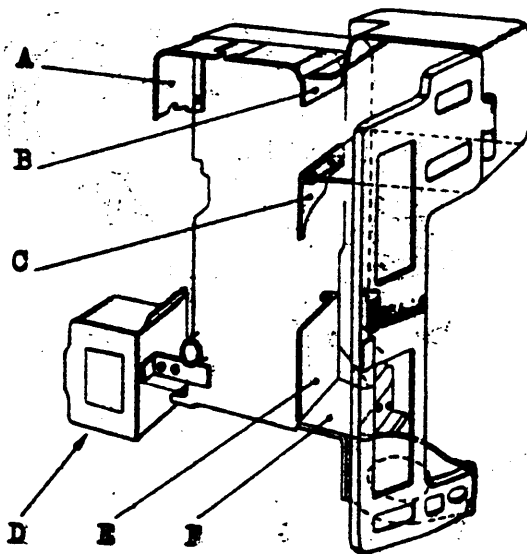
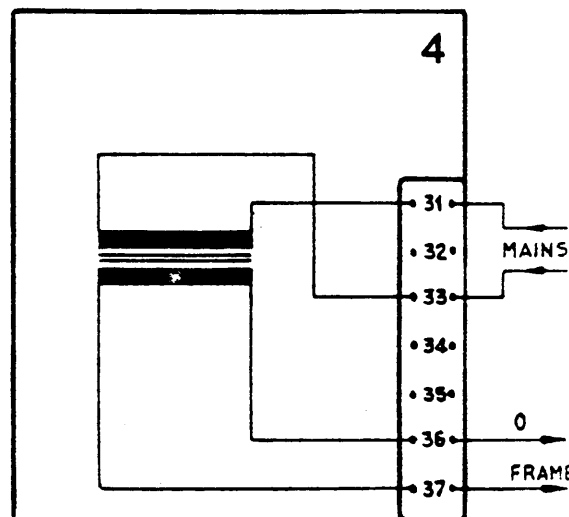
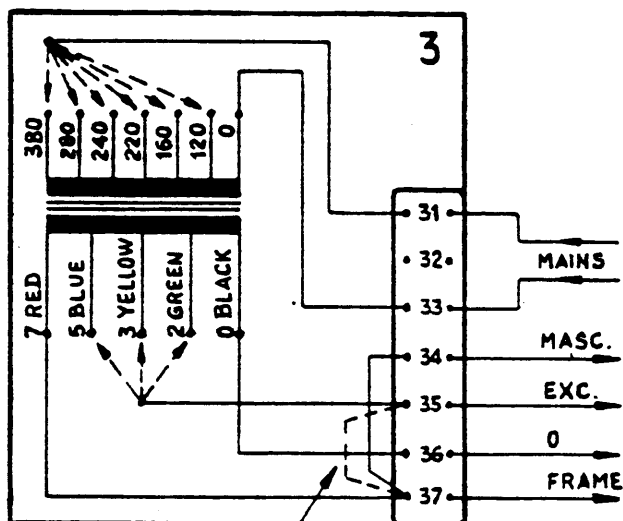
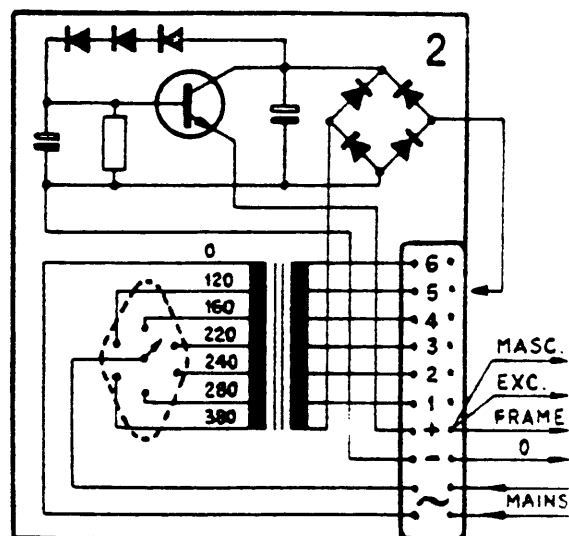
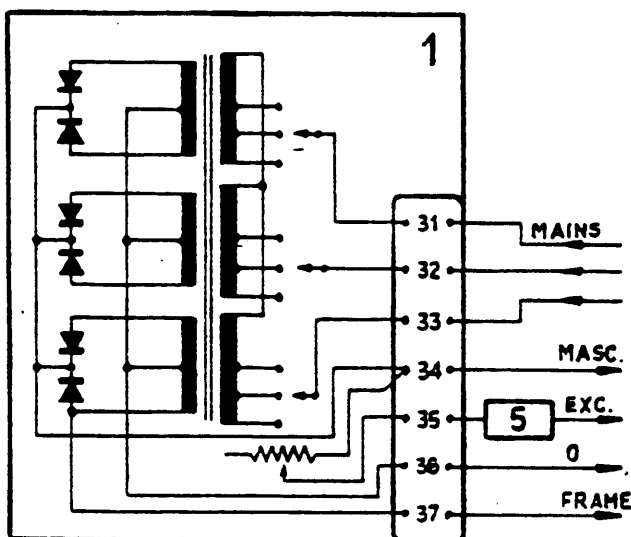
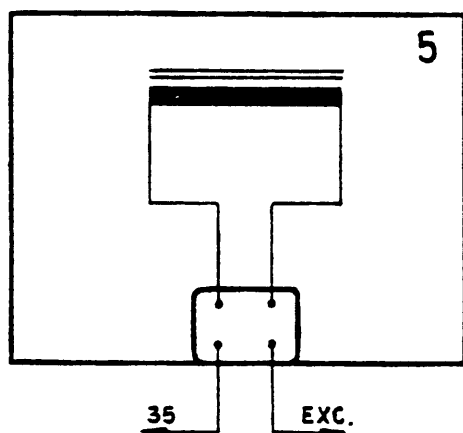

FIG. 11



With rheostat and P.E. Cell



- 1 - D.C. power supply for exciter and framing lamps: threephase mains
- 2 - D.C. power supply for exciter and framing lamps: singlephase mains
- 3 - A.C. power supply for exciter and framing lamps
- 4 - A.C. power supply for framing lamps
- 5 - Smoothing choke for exciter lamp current (on request)

FIG. 12

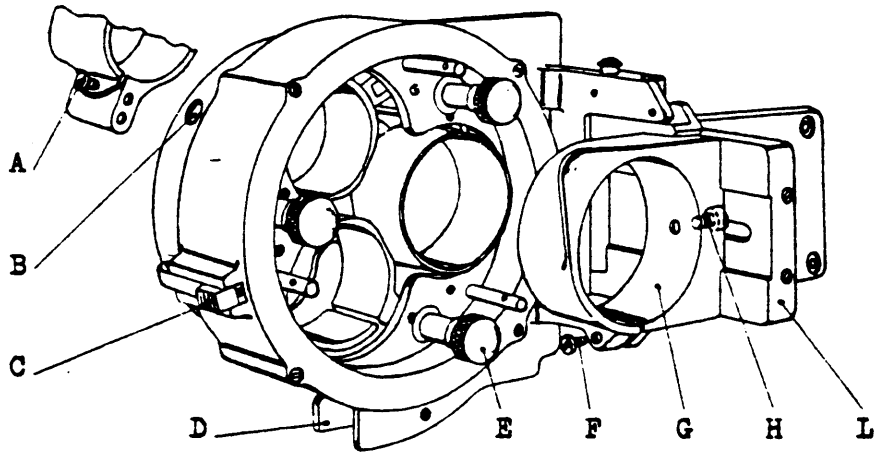

FIG. 13

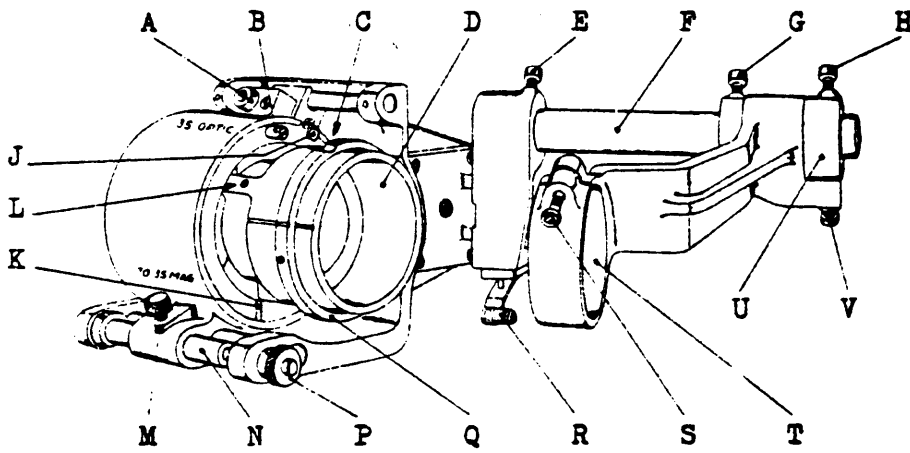

FIG. 14

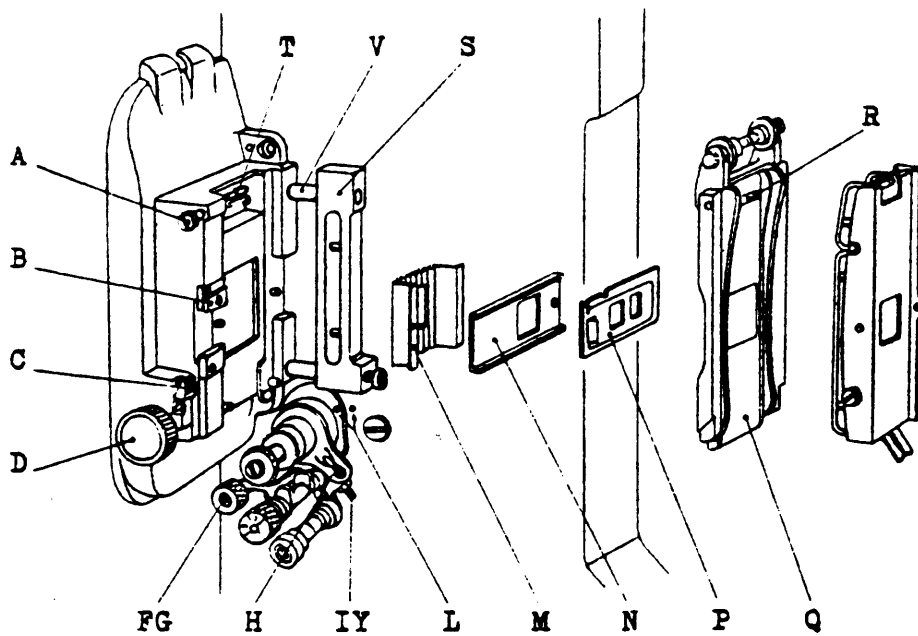

FIG. 15

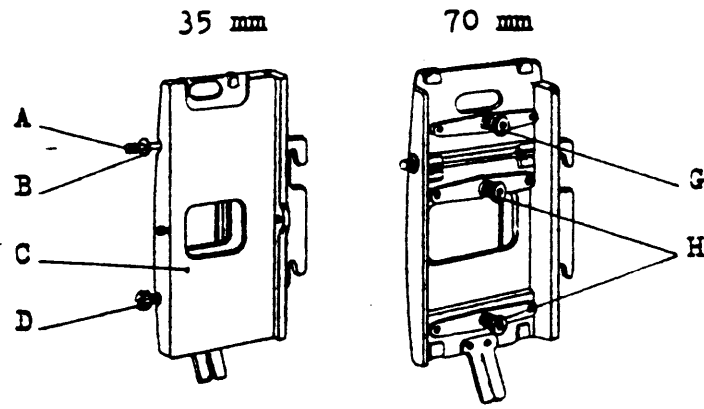

FIG. 16

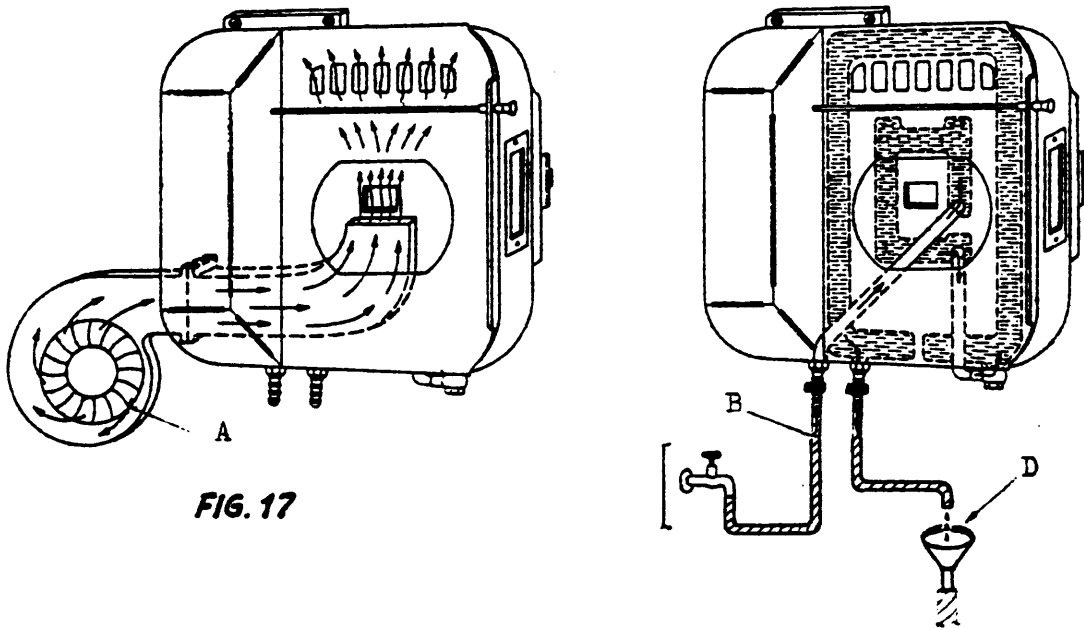

FIG. 17

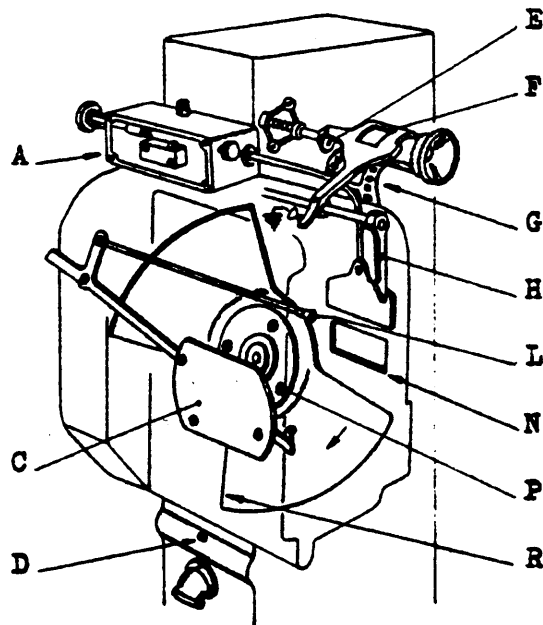

FIG. 18

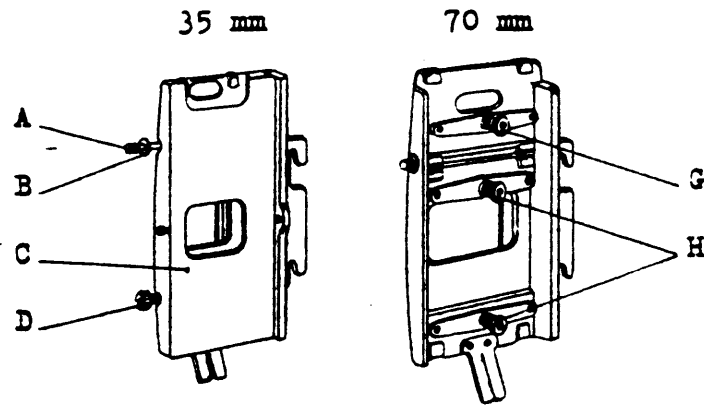

FIG. 16

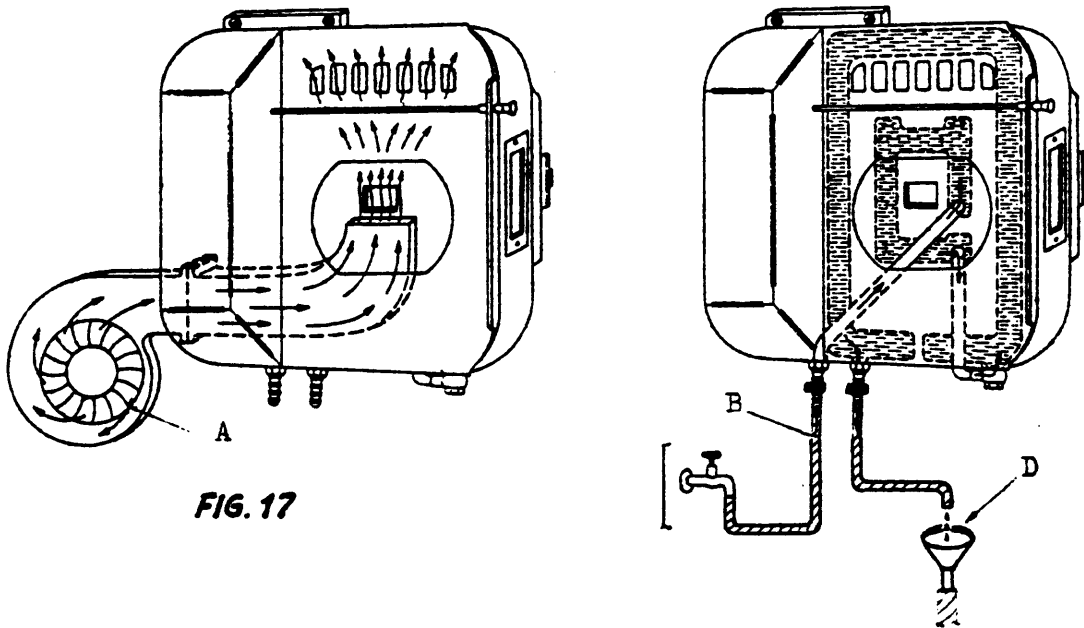

FIG. 17

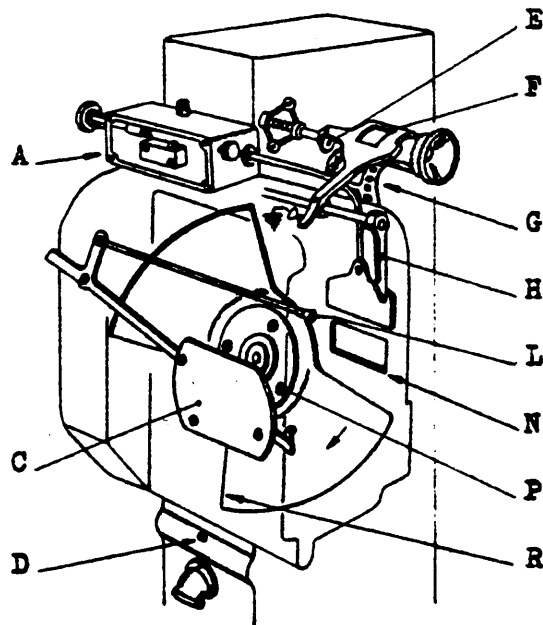

FIG. 18

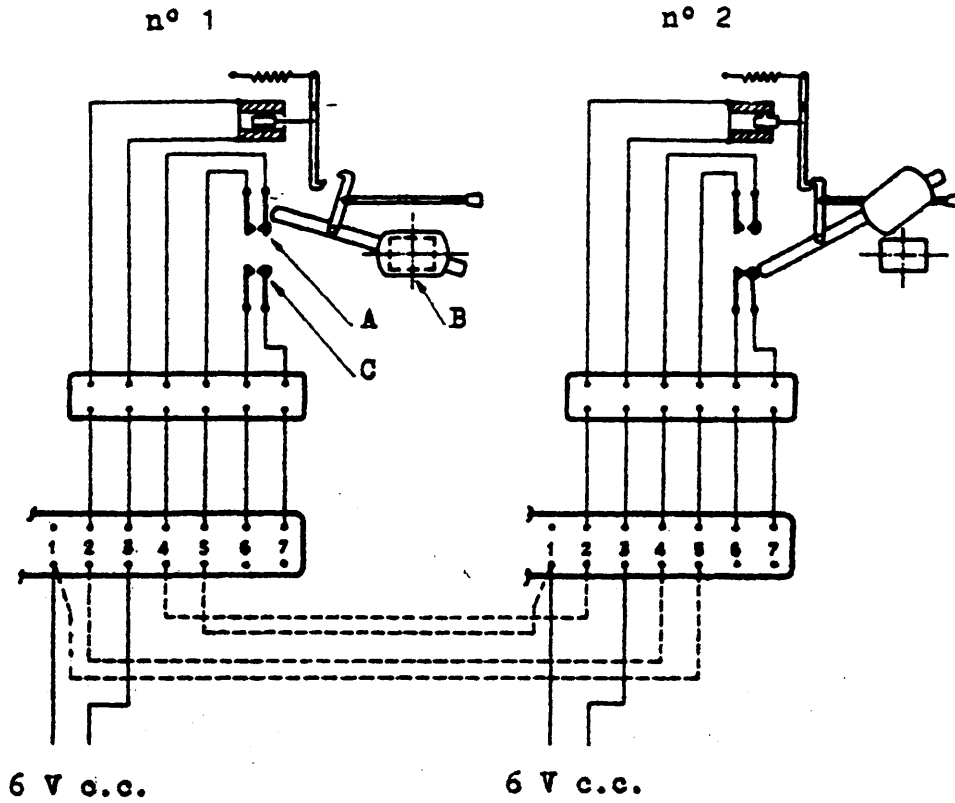

FIG. 19

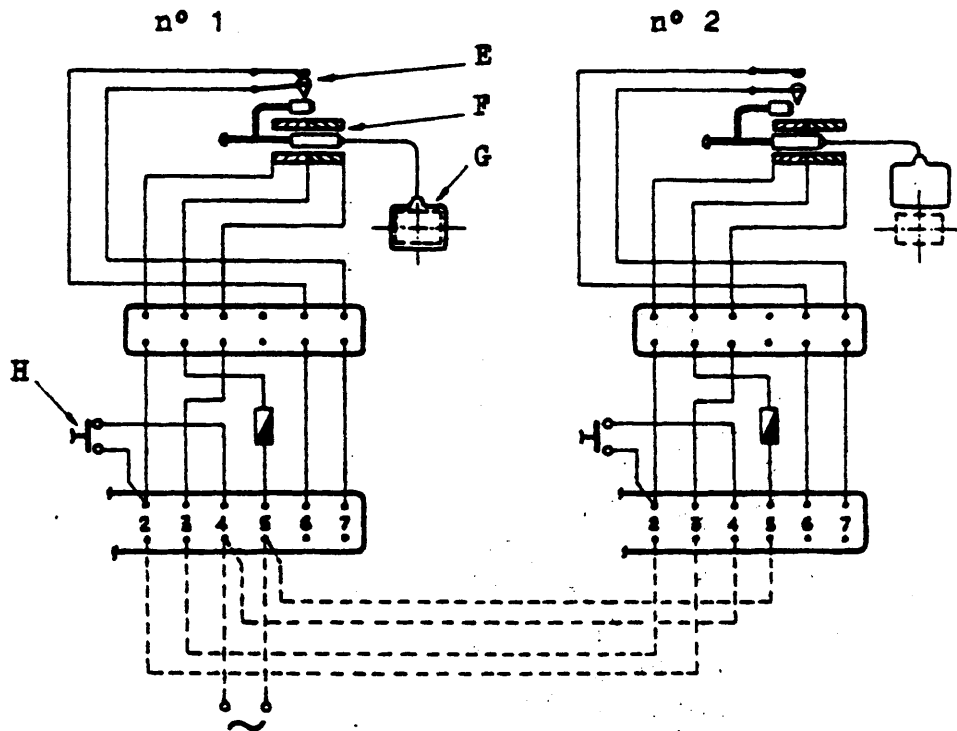

FIG. 20

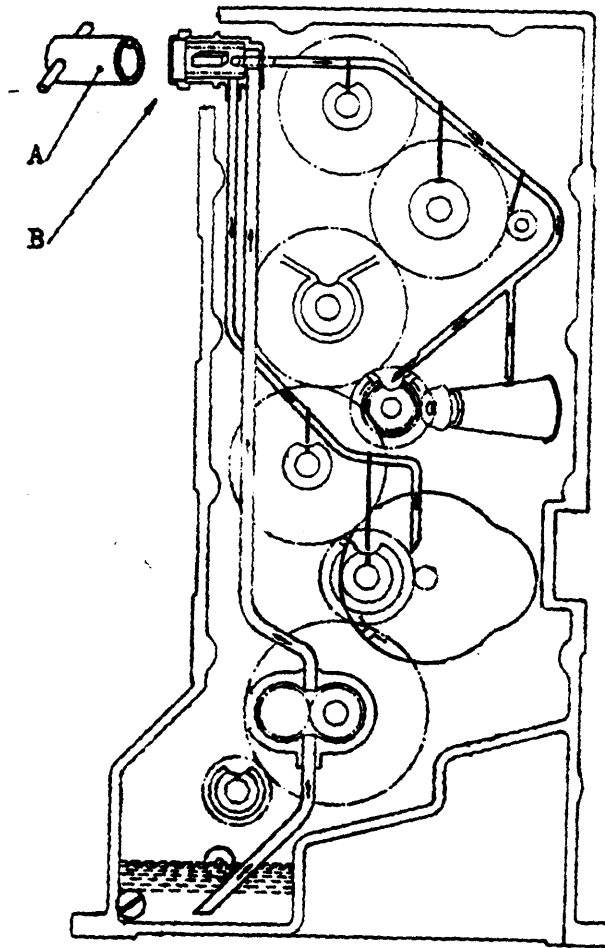

FIG. 21

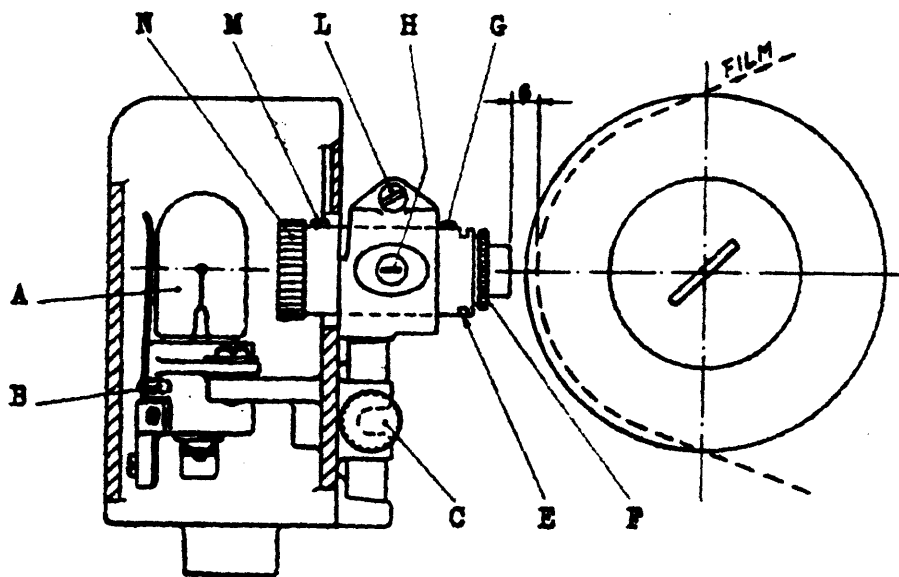

FIG. 22

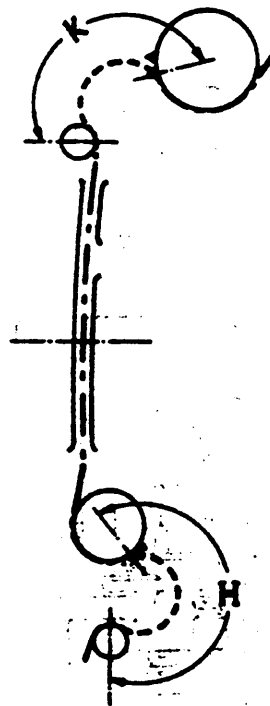
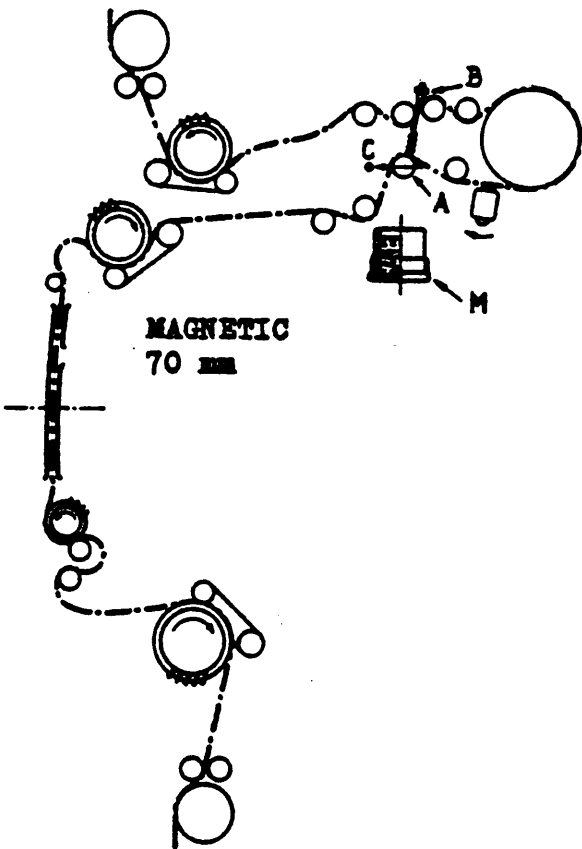
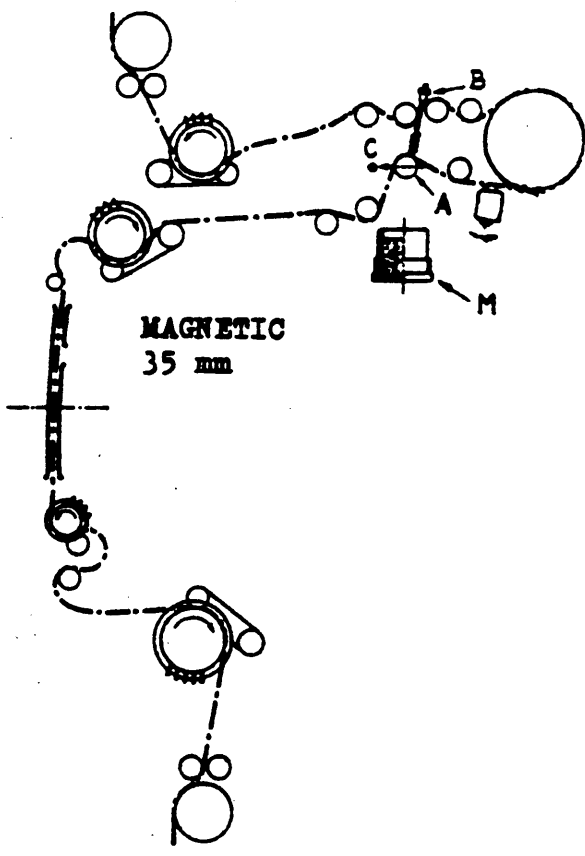
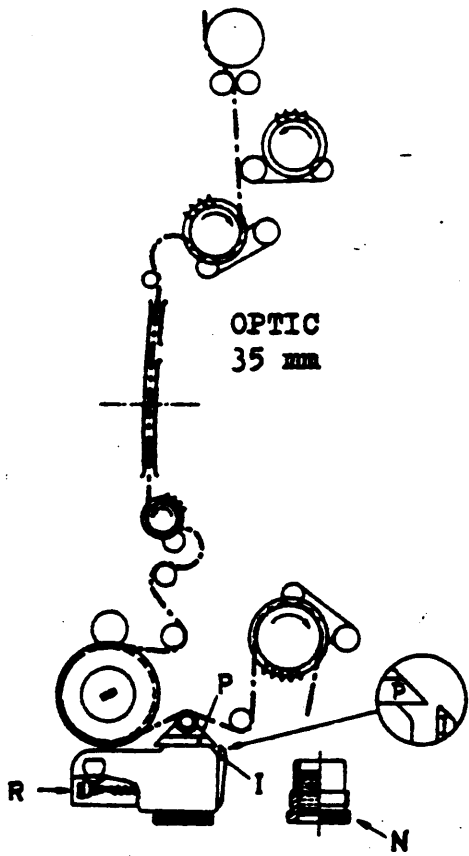
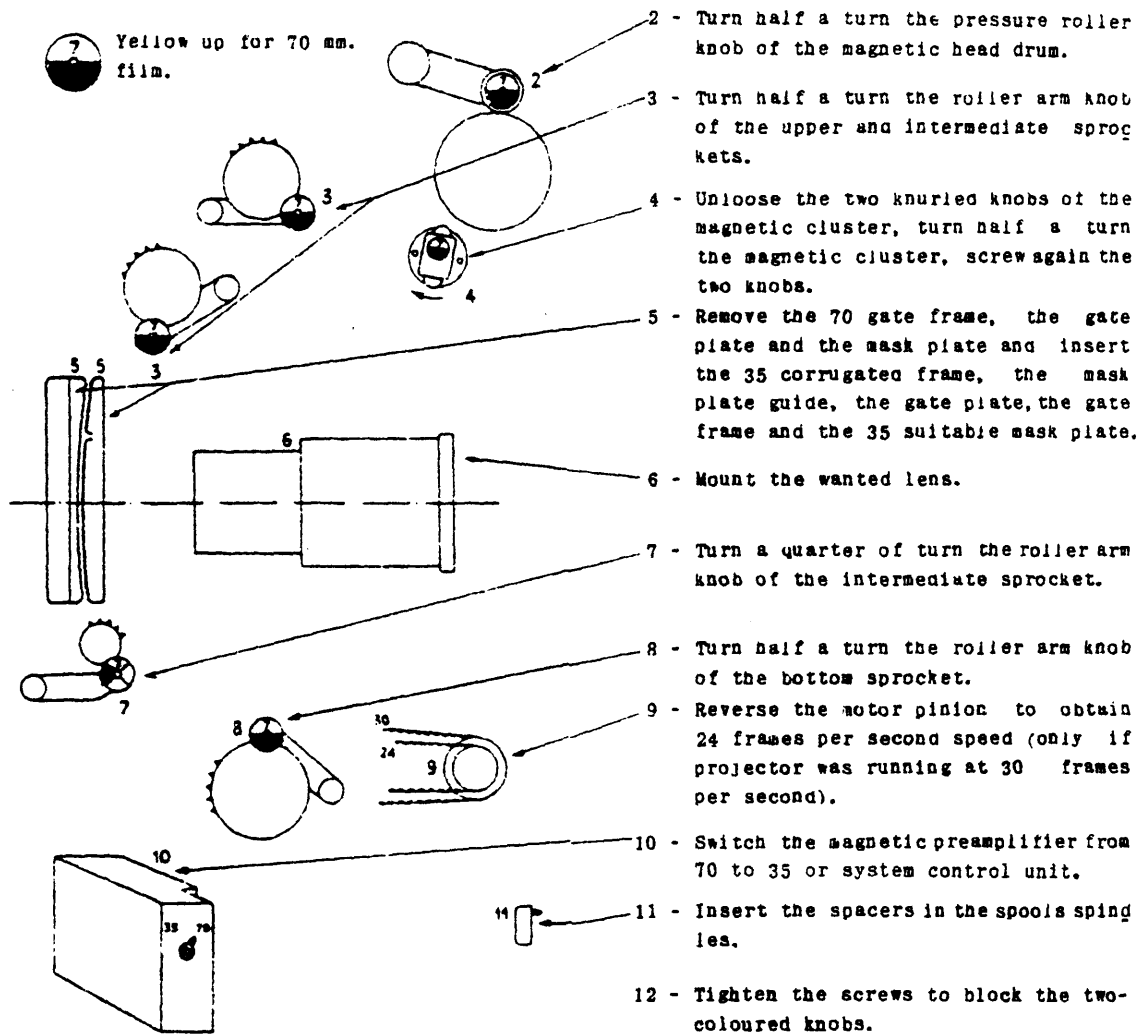

FIG. 23

HOW TO CHANGE FROM 70 TO 35 mm.
PROJECTION AND VICE-VERSA.

Change from 70 to 35 mm. projection

The sketch represent the mechanism ready for 70 mm film threading.



After the interchange has been performed, carefully control that:
all the two-coloured knobs present the red up and
all the screws \oplus have been duly tightened

Change from 35 to 70 mm. projection

Perform same operations vice-versa, i.e.: unloose the screws \oplus , rotate all the two-coloured knobs and the magnetic cluster in order that they present the yellow up. Remove the gate frame, the gate plate, the mask plate guide, and the corrugated frame. Insert the gate plate, the gate frame and the 70 mask plate. Mount the wanted lens. Change speed if required. Switch the magnetic preamplifier from 35 to 70. Take away the spacers from the spools spindles.

After the interchange has been performed, carefully control that:
all the two-coloured knobs present the yellow up and
all the screws \oplus have been duly tightened.

FIG.24

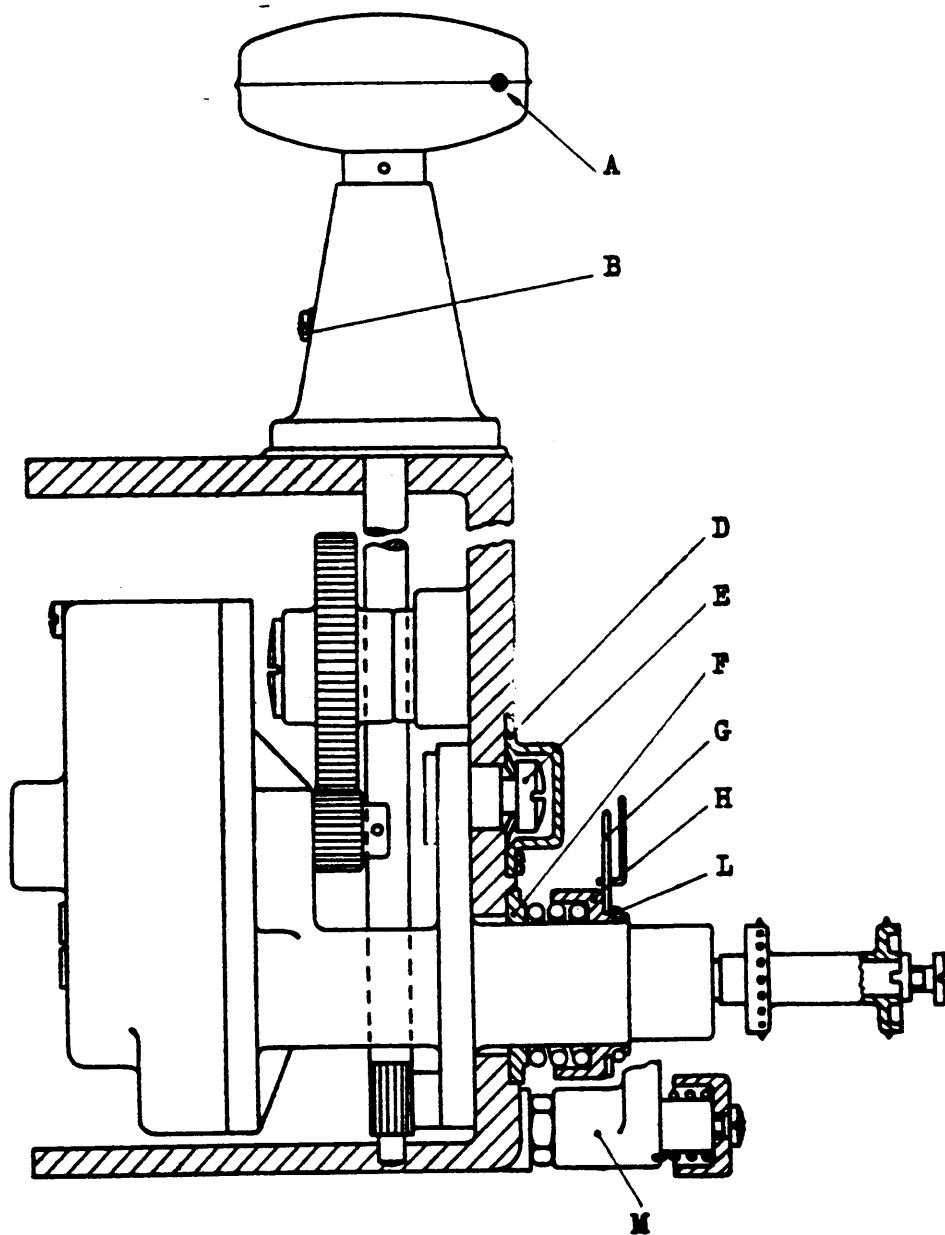
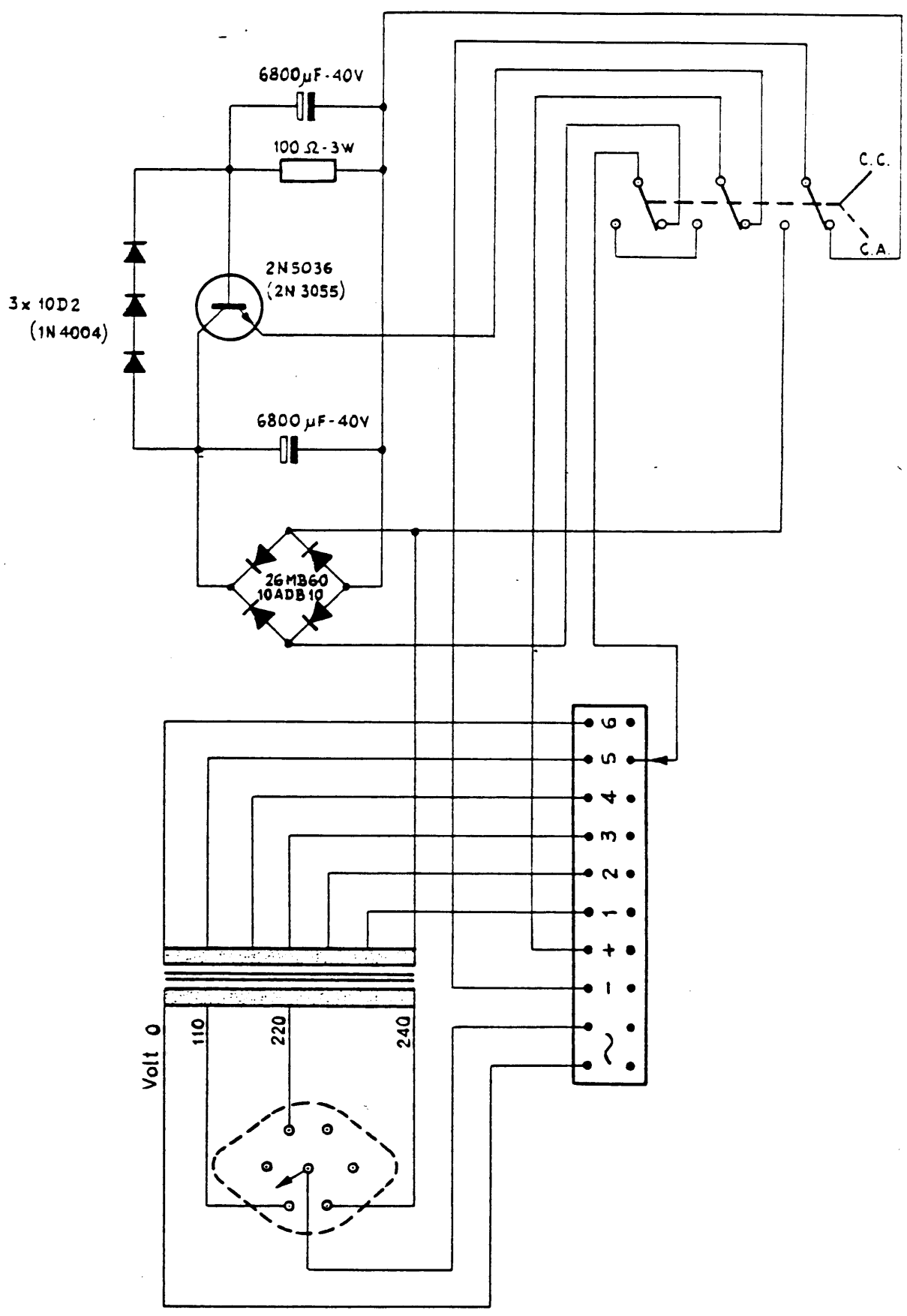

FIG. 25



Data 17-4-70
Modifiche
Rifatto
6-1-82



VICTORIA 8-70/35 PROIETTORE

Percorsi del film - Parcours du film - Film threadings

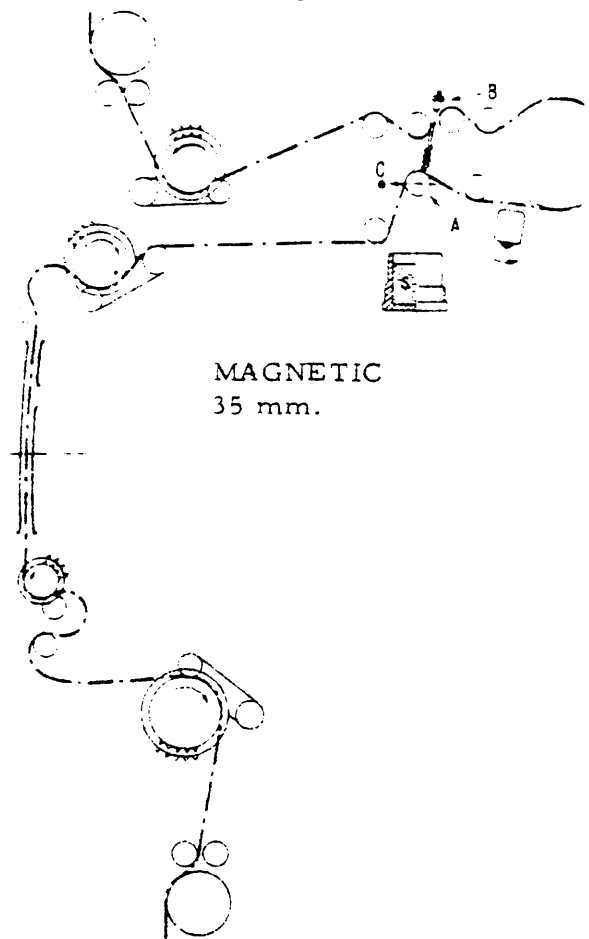
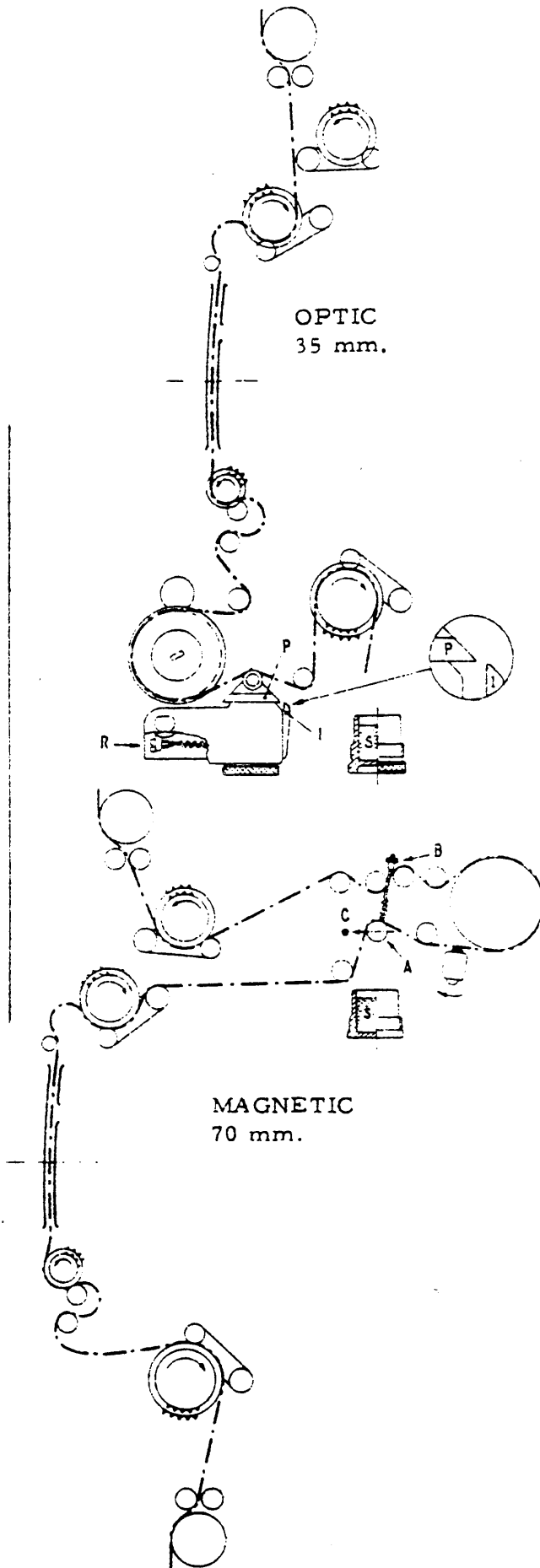
COMPENSATORI IDRAULICI

Riempimento - Svitare i bicchierini, riempirli di liquido S sino ad un centimetro dal bordo e riavvitarli in sede.

Regolazione lettore ottico - Montare il film e mettere in moto il proiettore, ruotare la vite R sino a che il bordo inferiore di P coincida con l'indice I.

Regolazione lettore magnetico - Montare il film e mettere in moto il proiettore, ruotare il bottone B sino a portare l'asse del rullino A all'altezza del punto C segnato in rosso.

COMPENSATEURS HYDRAULIQUES

Remplissage - Dévisser les godets, et les remplir de liquide S jusqu'à 1 cm. du bord supérieur.

Réglage du lecteur optique - Une fois le film monté et avec le projecteur en marche, tourner la vis R jusqu'à ce que le bord inférieur du support P vienne à coïncider avec l'index I.

Réglage du lecteur magnétique - Une fois le film monté et avec le projecteur en marche, tourner le bouton B jusqu'à ce que l'axe du galet A corresponde avec le point rouge C.

DAMPERS ADJUSTMENT

Filling - Unscrew the pots, fill them with fluid "type S" till $\frac{1}{4}$ " from the rim then retighten the pots.

Optical head damper adjustment - Thread the film and, while the mechanism is running, rotate the screw R until the bottom edge of P corresponds to the pointer I.

Magnetic head damper adjustment - Thread the film and while the mechanism is running, rotate the knob B until the roller center line A corresponds to the red spot C.