

Film-Tech

The information contained in this Adobe Acrobat pdf file is provided at your own risk and good judgment.

These manuals are designed to facilitate the exchange of information related to cinema projection and film handling, with no warranties nor obligations from the authors, for qualified field service engineers.

If you are not a qualified technician, please make no adjustments to anything you may read about in these Adobe manual downloads

www.film-tech.com

Regular Maintenance

Intermittent unit oil change:	1st change	50 hours
	2nd change	150 hours
	periodic change	every 500 hours
Belts replacement:	MI (forward-reverse)	1000 hours
	standard	2000 hours
MI (f/r) brake roller rotation (No. 8V-7405-11):		to projectionist's judgement
Mechanism bearings greasing:		not needed
Dashpot oil change:		every year
Optical sound head roller arm:		to be greased every month
Optical sound head shaft:		to be oiled every 400 hours
Film pressure pads:		to projectionist's judgement
Sprockets:		to projectionist's judgement
Nylon rollers (removal or cleaning):		every month
Film path cleaning:		every day
Clutch felts:		to be oiled every month
Clutch shaft bearings:		to be oiled every 2 months

Special Maintenance

- 1) Intermittent unit
- 2) Shutter
- 3) Shutter drive assembly
- 4) Picture-sound microswitch assembly and Mascarini
- 5) Safety dowser solenoid
- 6) Upper/lower sprocket shaft assembly
- 7) Optical sound head
- 8) Gate pad replacement
- 9) Replacement of pressure pads
- 10) Dashpot assembly
- 11) Replacement of exciter lamp housing assembly
- 12) Shutter phasing
- 13) Belts replacement (it is recommended to loosen the idler pulley)
- 14) Weight compensated clutch adjustment with dynamometer
- 15) Replacement of 24 tooth MI (forward/reverse) sprocket shaft.

(1) Intermittent Unit Replacement

Wrenches and tools needed:

- a) Wrenches for metric Allen screws M4, M5, M8 - UNI 5931
- b) Pliers for circlips
- c) 4mm dia. cylindrical pin.

As replacement unit we supply No. 5V-400-01 assembly shown on Fig. 5, but without parts No. 5V-438, 5V-436, 5V-425, 8V-466, 8V-469, 8V-470, 8V-471, 8V-472, 001C, 0025.

Remove the damaged unit according to the following procedure:

- 1) Remove the back cover of the main casting unlocking the two spring detents.
- 2) Loosen No. 5V-160 top belt idler (Fig. 1).
- 3) Loosen the screws of No. 5V-325 belt containment rollers (in some models they are still replaced by No. 00839 bearings).
- 4) Remove No. 5V-436 pinion taking off the screw connecting it to the shaft.
- 5) Take away No. 5V-170 mechanism belt (Fig. 1).
- 6) Take off the screw connecting No. 5V-438 assembly to No. 5V-449 spindle.
- 7) Take away No. 22-3654 circlip using the pliers.
- 8) Slip off No. 5V-438 assembly.

Now proceed on the outside of the main casting.

- 9) Remove No. 8V-597 intermittent sprocket roller arm assembly (Fig. 3) and the 16 tooth 001C (or 001) sprocket loosening the screw which fastens No. 0025 washer with key.
- 10) Take away No. 8V-472 circlip.
- 11) Using the 4mm dia. cylindrical pin, loosen No. 8V-469 spring adjusting bush, remove No. 8V-466 spring and No. 5V-425 clutch washer.
- 12) Take away the intermittent unit.

Replace the unit with a new one and repeat the above steps backwards.

Note: When refitting No. 8V-469 bush, tighten it first and then loosen it for one fourth of a turn to load the spring correctly.

It is necessary to phase the shutter after the intermittent unit has been replaced: please refer to paragraph No. 12.

(2) Shutter Replacement

Wrenches and tools needed:

- a) Wrench for metric Allen screws M4 - UNI 5931.

The replacement shutter is supplied as per part No. 5V-339 on Fig. 4.

Remove the damaged shutter according to the following procedure:

- 1) Remove the lamphouse cone.
- 2) Take off the screws fastening No. 5V-372 microswitch cover.
- 3) Take off the three screws fastening No. 5V-346 shutter cover, which can be taken away together with all parts mounted on it. Attention should be paid not to damage the electrical connections.
- 4) Remove the two screws which fasten both No. E-279 shutter locking disc and No. 5V-339 shutter.
- 5) Slip off No. E-279 shutter locking disc.
- 6) Replace the shutter.
- 7) Refit No. E-279 shutter locking disc and do not tighten fully the screws fastening it.
- 8) Carry out the shutter phasing as per paragraph No. 12.

Repeat the above steps backwards starting from point 4).

Note: The shutter cooling fins should be facing the lamphouse.

(3) Shutter Drive Assembly Replacement

Wrenches and tools needed:

- a) Wrenches for metric Allen screws M4, M5, M8 - UNI 5931
- b) Hexagonal tube metric wrench No. 17
- c) Pliers for circlips.

As replacement we supply No. 5V-305 assembly shown on Fig. 4. Remove the damaged assembly according to the following procedure:

- 1) Remove the back cover of the main casting unlocking the two spring detents.
- 2) Take off the screws fastening No. 5V-372 microswitch cover.
- 3) Take off the three screws fastening No. 5V-346 shutter cover, which can be taken away together with all parts mounted on it. Attention should be paid not to damage the electrical connections.
- 4) Remove the two screws which fasten both No. E-279 shutter locking disc and No. 5V-339 shutter.
- 5) Take off the screw connecting No. 5V-438 assembly to No. 5V-449 spindle (Fig. 5).
- 6) Loosen the screws of No. 5V-325 belt containment rollers - Fig. 5 (in some models they are still replaced by No. 00839 bearings).
- 7) Loosen No. 5V-160 top belt idler (Fig. 1).
- 8) Take away No. 5V-170 mechanism belt (Fig. 1).
- 9) Using the pliers, take away No. 22-3654 circlip (Fig. 5) which fastens the roller support plate on to the intermittent unit. Slip off the support plate.
- 10) Unscrew No. 5V-449 spindle (Fig. 5) from the bottom of the main casting, using the tube wrench.
- 11) Loosen completely the screws fastening No. 5V-305 shutter drive assembly to the main casting.
- 12) Replace the damaged assembly.

Repeat the above steps backwards.

Note: When mounting the replacement assembly, be careful that No. 5V-436 pulley (Fig. 5) will be aligned with No. 5V-118 pulley (Fig. 2). To do so, use the play around the screws.

After this replacement, phasing of the shutter is to be carried out as per paragraph No. 12.

(4) Replacement of Picture-Sound Microswitch Assembly or Mascarini Microswitch Assembly

Wrenches and tools needed:

- a) Wrenches for metric Allen screws M3 and M4 - UNI 5931.

As replacements we supply parts No. 9V-444 and No. 9V-440 shown on Fig. 4.

Remove the damaged piece according to the following procedure:

- 1) Take away the lamphouse cone.
- 2) Take off the screws fastening No. 5V-372 microswitch cover.
- 3) Take off the screws connecting the microswitch assembly to be replaced to No. 5V-346 shutter cover. The Mascarini assembly is the one driven by No. 5V-336 front governor plate located on No. 5V-317 shutter shaft. The picture-sound microswitch assembly is driven by No. 5V-349 safety dowser lever.
- 4) Mount the replacement placing the electrical connections in the same original position.

Repeat the above steps backwards.

(5) Replacement of Safety Dowser Solenoid

Wrenches and tools needed:

- a) Wrenches for metric Allen screws M3 and M4 - UNI5931
- b) Screwdriver
- c) No. 6 Wrench for hexagonal nut.

A solenoid assembly can be ordered as replacement. It includes the coil, the core and the rod connecting the core to No. 5V-349 safety dowser lever. The solenoid can also be ordered without rod and spindle. Please refer to Fig. 4.

Remove the damaged solenoid according to the following procedure:

- 1) Take away the lamphouse cone.
- 2) Take off the screws fastening No. 5V-372 microswitch cover.
- 3) Loosen the two screws fastening the bracket with No. 5V-356 solenoid to No. 5V-346 shutter cover.
The coil can now be separated from the core, after having removed the electrical connections.
- 4) Replace the core and the rod (if mounted), loosening the screw which connects the rod to 5V-349 safety dowser lever to avoid coupling the old core to the new coil as this could impede motion.
- 5) Loosen the four screws fastening the coil on the bracket and locate the new coil.

Repeat the above steps backwards.

Note: When mounting the bracket referred to under the above step 3), attention should be paid to the two screw slots.

The whole core being inside the coil, the right location is obtained when the end of No. 5V-349 lever is positioned 2 ± 3 mm from No. 9V-452 rubber dowser stop. This will avoid vibrations during operation.

(6) Replacement of Upper/Lower Sprocket Shaft Assembly

Wrenches and tools needed:

- a) Wrenches for metric Allen screws M4, M6, M8 - UNI 5931
- b) Wrenches for hexagonal nuts M4 and M8.

The replacement is supplied according to part No. 5V-108 on Fig. 2.

Remove the damaged assembly as follows:

- 1) Loosen the nut locking No. 5V-135 upper roller arm assembly (Fig. 3) to relieve the spring.
- 2) Take away No. 8V-144 24 tooth sprocket loosening the stop nut.
- 3) Remove the back cover of the main casting, unlocking the two spring detents.
- 4) Loosen No. 5V-160 top belt idler assembly (Fig.1) and No. 5V-603 bottom belt idler (Fig. 6).
- 5) Loosen, without taking them off, the screws fastening No. 5V-325 (Fig. 5) belt containment rollers on the intermittent unit (in some models they are still replaced by No. 00839 bearings).
- 6) Take away both toothed belts.
- 7) Take the pulleys away from the shaft taking off the screw which keeps them in place.
- 8) Loosen the nut placed on the outside of the main casting, which locks the upper/lower shaft assembly.
- 9) Take away the shaft assembly pulling it from the non-operating side and replace it with the new one.

Repeat the above steps backwards.

Note: Mounting the replacement, be careful to perfectly align the 24 tooth sprocket with No. E-506 gate pad (Fig. 8) and with the other toothed sprockets.

(7) Replacement of Optical Sound Head Drum Bracket

Wrenches and tools needed:

- a) Wrenches for metric Allen screws M5 or M8 - UNI 5931
- b) Screwdriver
- c) Wrench for hexagonal nut.

The replacement is supplied according to part No. 5V-701 (Fig. 7) for the model with magnetic flywheel and according to part No. 5V-751 (Fig. 7bis) for the simplified model.

Remove the damaged part as follows:

- 1) Loosen the screw on the top of the drum shaft and take away No. 5V-710 drum fastening disc.
- 2) Slip off the outside drum.
- 3) Loosen the nut fastening No. E-118 part to relieve the spring.
- 4) Disconnect the cell.
- 5) Slip off No. 00261 cell housing.
- 6) Loosen and take away the three screws connecting No. 8V-743 cell bracket to the main casting. This bracket is doweled.
- 7) Take off the two screws fastening to the main casting the bracket to be replaced.

Repeat the above steps backwards.

Note: When mounting the replacement, be sure to align the track between the two drums with No. 9V-263 pressure rollers.
Lock the bracket fixing screws firmly, without remounting the dowels in the main casting.

(8) Gate Pad Replacement

Wrenches and tools needed:

a) Screwdriver.

The pad to be replaced is part No. E-506 (Fig. 8).

Remove the damaged part as follows:

- 1) Open the gate using No. E-512 gate release lever.
- 2) Loosen No. E-510 gate pad stop spindle.
- 3) Slip off the pad from the bottom to the top.
- 4) Rest the new pad inserting the wedge under the cone of the two bottom screws placed near No. 0013 grooved roller.

Repeat steps 1) and 2) backwards.

Note: After locating the pad, its upper part must not touch No. 007 spring guide roller, which is placed on the top of the gate bracket. If this is not so, the wedge on the opposite bottom of the pad should be slightly filed.

(9) Replacement of Pressure Pads

The pads to be replaced are shown as No. E-581 on Fig. 8.

Remove the damaged part as follows:

- 1) Loosen the two 0029 spring adjusting knobs without unscrewing them fully.
- 2) Open the gate using No. E-512 gate release lever.
- 3) Pull No. 00274 lower push plate toward the lens, overcoming the spring and rotate by 90 degrees.
- 4) Lift up with a finger the pad and slip it off pulling it from the top.

Repeat the above steps backwards.

Note: The loading on the pad adjusting springs should not be too little, otherwise the picture will flicker, and not too much to avoid early film wear.

The proper adjustment is found loosening the springs until a clatter is heard, and then loading them by tightening the screws just a bit to obtain a steady picture.

(10) Dashpot Assembly Replacement

Wrenches and tools needed:

- a) Wrench for metric Allen screws M4 - UNI 5931.

The replacement is supplied as per part No. 8V-774 on Fig. 12.

Remove the damaged assembly as follows:

- 1) Unscrew No. 10-792 oil tank completely.
- 2) Take off the four screws fastening the dashpot on to the main casting.
- 3) Mount the replacement and pour the special damper oil into the new pot to the right level.

(11) Replacement of Exciter Lamp Housing Assembly

Wrenches and tools needed:

- a) Wrench for metric Allen screws M4 - UNI 5931
- b) Screwdriver.

The replacement is supplied as per Fig. 13, and includes all the items shown with the exception of numbers 8V-794 and 00398.

Remove the damaged part according to the following procedure:

- 1) Loosen the screw which fastens the outside drum of the optical sound head.
- 2) Take away the drum, paying attention to the pin which connects the drum to No. 5V-710 drum fastening disc (Fig. 7).
- 3) Remove the dashpot, see paragraph No. 10.
- 4) Uncover the exciter lamp housing and disconnect the electrical wires. It is not necessary to connect the wires according to a preset scheme as the lamp holder is not earthed.
- 5) Loosen the screw which is used to adjust the sound lens alignment. It is located on the exciter lamp housing side.
- 6) Take off the screw connecting the part to be replaced to No. 8V-794 exciter lamp housing bracket.
- 7) Replace the damaged part.

Repeat the above steps backwards.

Note: When mounting the replacement, be careful to center the light beam which should be perfectly focussed and horizontal on the center line of the optical track. It should also be as wide as possible in accordance with the width of the sound optical track.

Use for alignment the necessary test films (buzz track for position and width, 9kHz for azimuth).

(12) Shutter Phasing

After removing the intermittent unit or the shutter drive assembly, it is necessary to phase the shutter with the intermittent movement to have a sharp picture.

To do so, after removing the lamphouse cone and No. 5V-372 microswitch cover (Fig. 4), turn the motor by hand until the pin engages a slot of the Maltese cross. This can be noticed when the 16 tooth sprocket (001 or 001C) starts moving.

Loosen the two Allen screws which fasten the shutter, and turn it till the bottom of the shutter blade, which turns C.W., has almost dimmed the aperture, as shown on the figure.

Now tighten the screws fully.

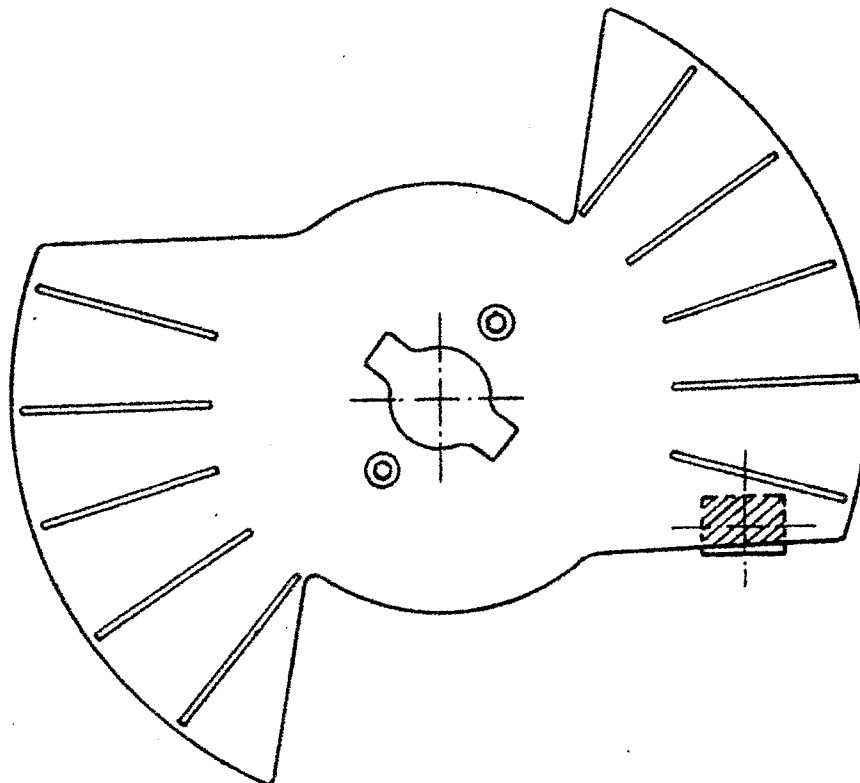

(13) Belts Replacement

Wrenches and tools needed:

- a) Wrench for metric Allen screws M5 - M6 - M8 - UNI5931.

To replace worn belts, proceed according to the following steps.

To replace "B" belt, remove first the "A" belt.

- 1) Take away the back cover of the main casting unlocking the two spring detents.
- 2) Loosen No. 5V-603 bottom belt idler (Fig. 6) and slip off the "A" belt from motor pinion.
- 3) Loosen No. 5V-160 top belt idler (Fig. 1) and the screws of No. 5V-325 belt containment rollers (Fig. 5) (in some models they are still replaced by No. 00839 bearings). Slip off the "B" belt from No. 5V-438 bracket (Fig. 5).
- 4) Replace the "B" belt mounting it first on No. 5V-438 bracket (Fig. 5) and be sure that the red marked dots on No. 5V-436 (Fig. 4 and Fig. 5) 13 tooth pulleys coincide with the dots on No. 5V-305 shutter drive assembly (Fig. 4) and on No. 5V-439 idler bracket (Fig. 5). Also, the belt between the two pinions should be well tensioned. Fit the belt on No. 5V-118 inside sprocket pulley (Fig. 2) and on No. 5V-160 belt idler (Fig. 1).
After doing so, turn the projector manually and be sure that the red dots coincide.
Now, tighten the screws of No. 5V-325 belt containment rollers (Fig. 5) (in some models they are still replaced by No. 00839 bearings).
- 5) Replace the "A" belt mounting it first on No. 5V-118 outside sprocket pulley (Fig. 2) and then on the motor pinion. Fasten No. 5V-603 lower belt idler (Fig. 6).
- 6) Pull the belts with a force of 0.800 Kg. half way between the two pulleys. There should be a camber of 12mm as shown on the figure (please turn over).
- 7) Tighten the screws of the belt idlers.
- 8) Mount the back cover of the main casting and lock the two spring detents.

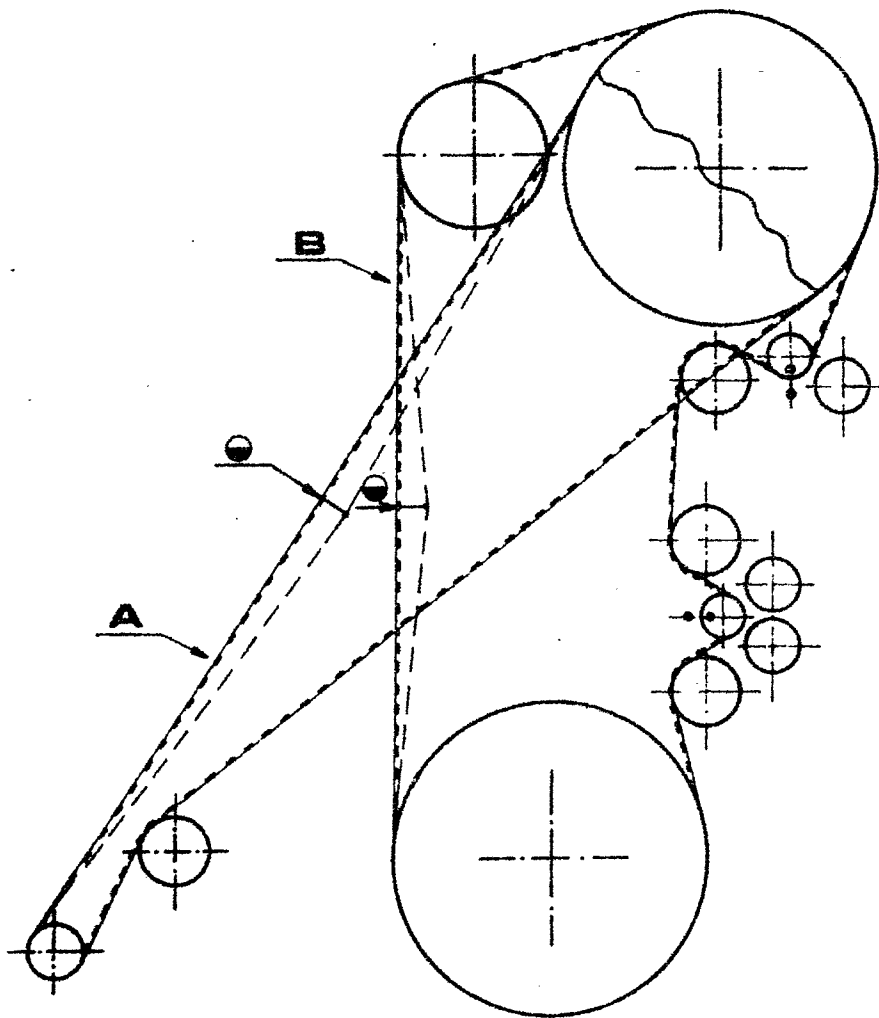

● kg. 0.800 - mm. 12

Disegnato da
 Controllato da
 da



VICTORIA 5

Ruotismi e tensione cinghie
 Toolhed pulleys and belts

7499

Dal N° 3500

Data 23-12-75
 Modifiche

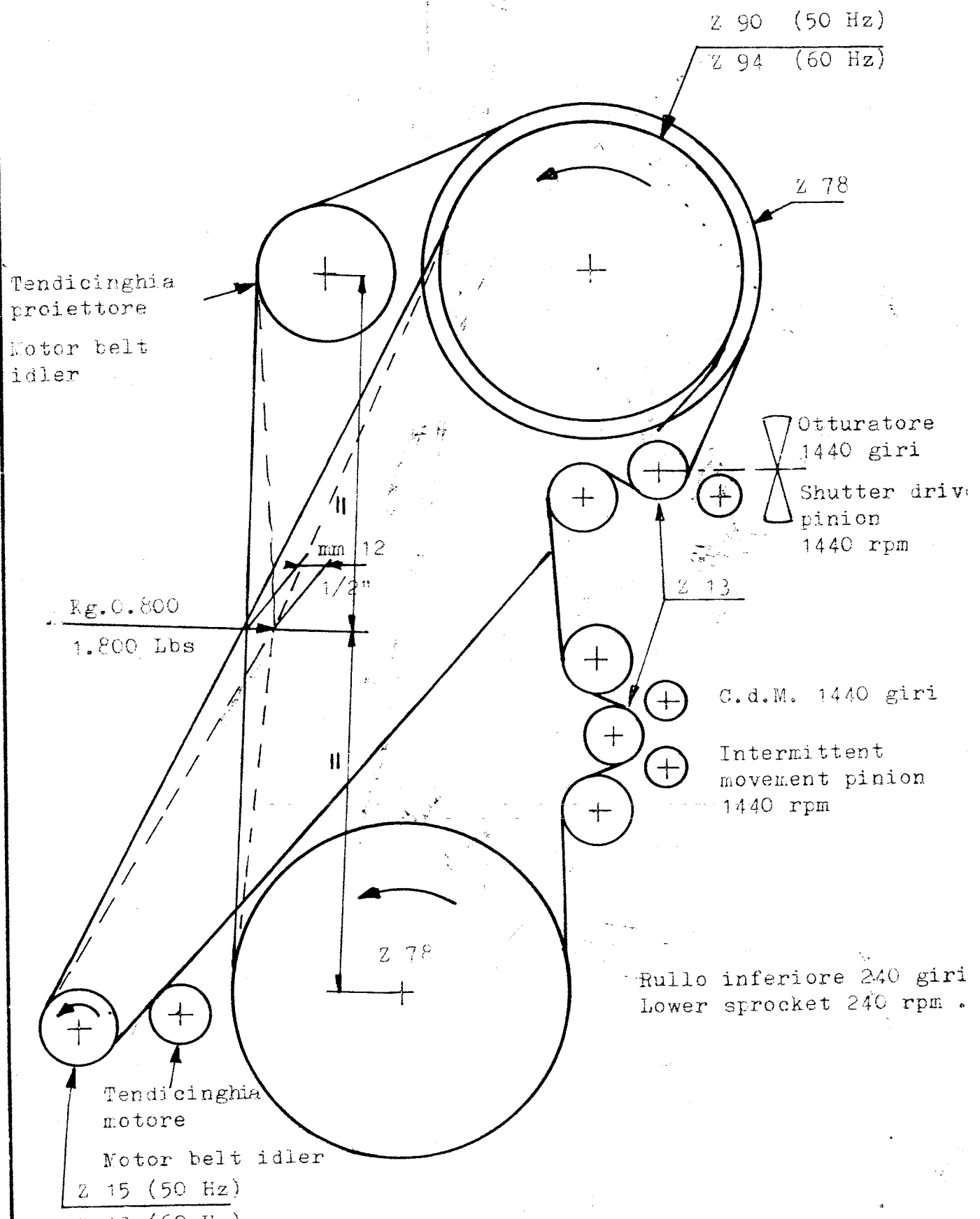

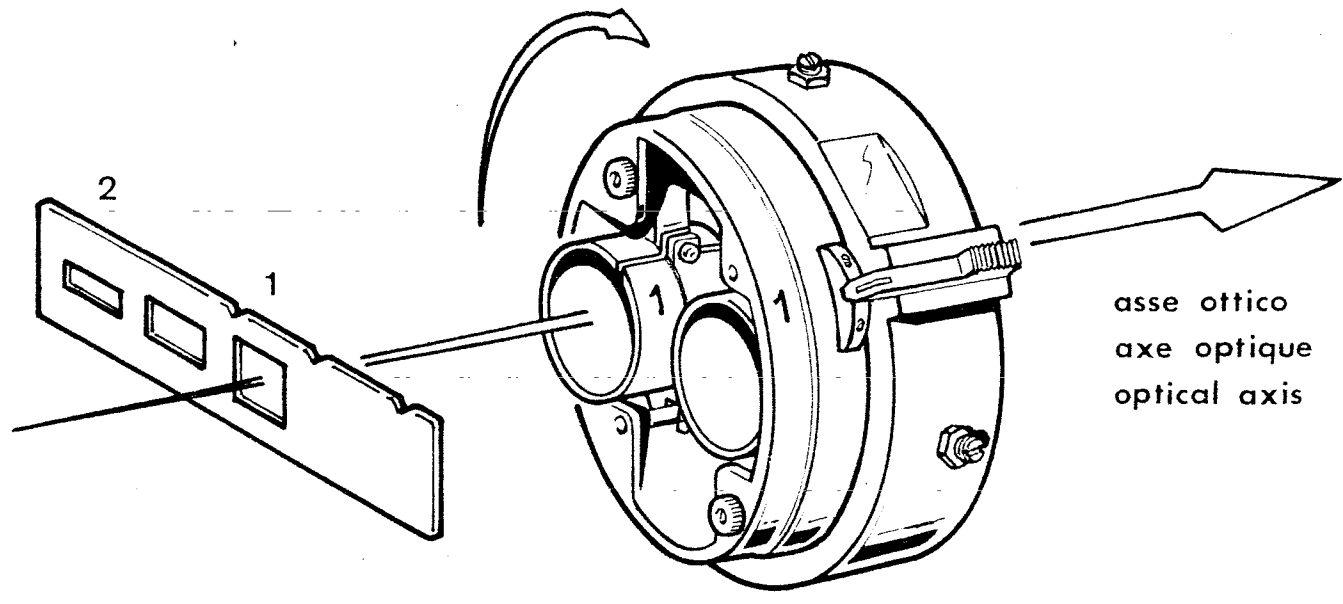
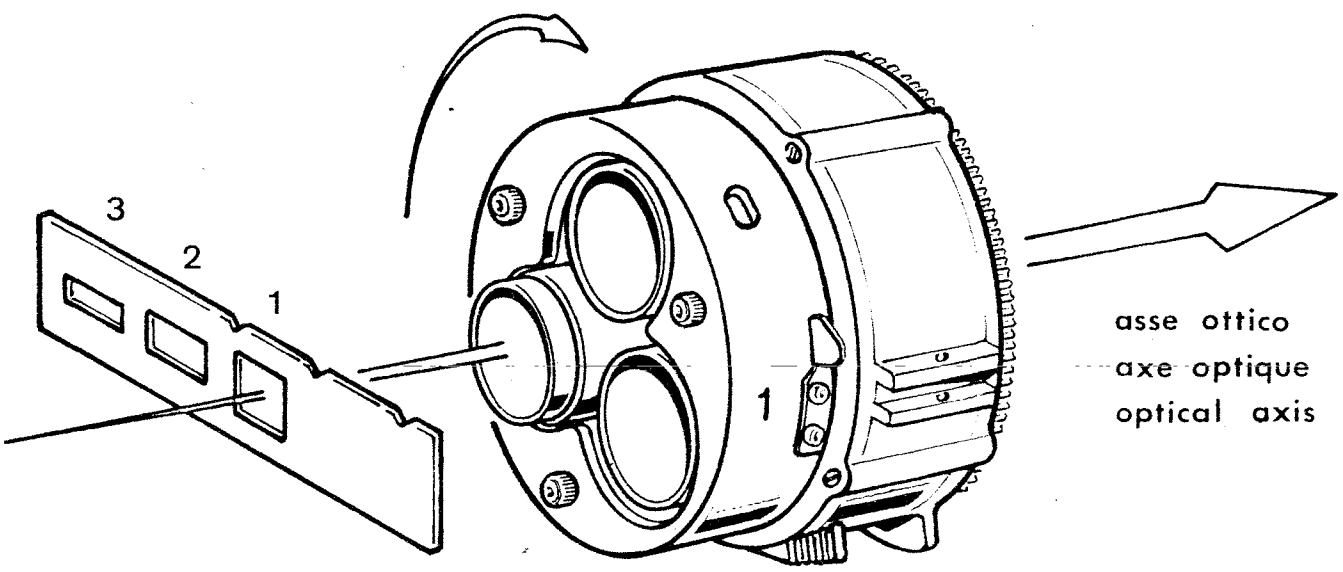

Disegnato
da *Fugiero*
Controllato
da



VICTORIA 5

Messa in fase proiettore - Shutter phasing

7478

Data 3-10-75
Modifiche

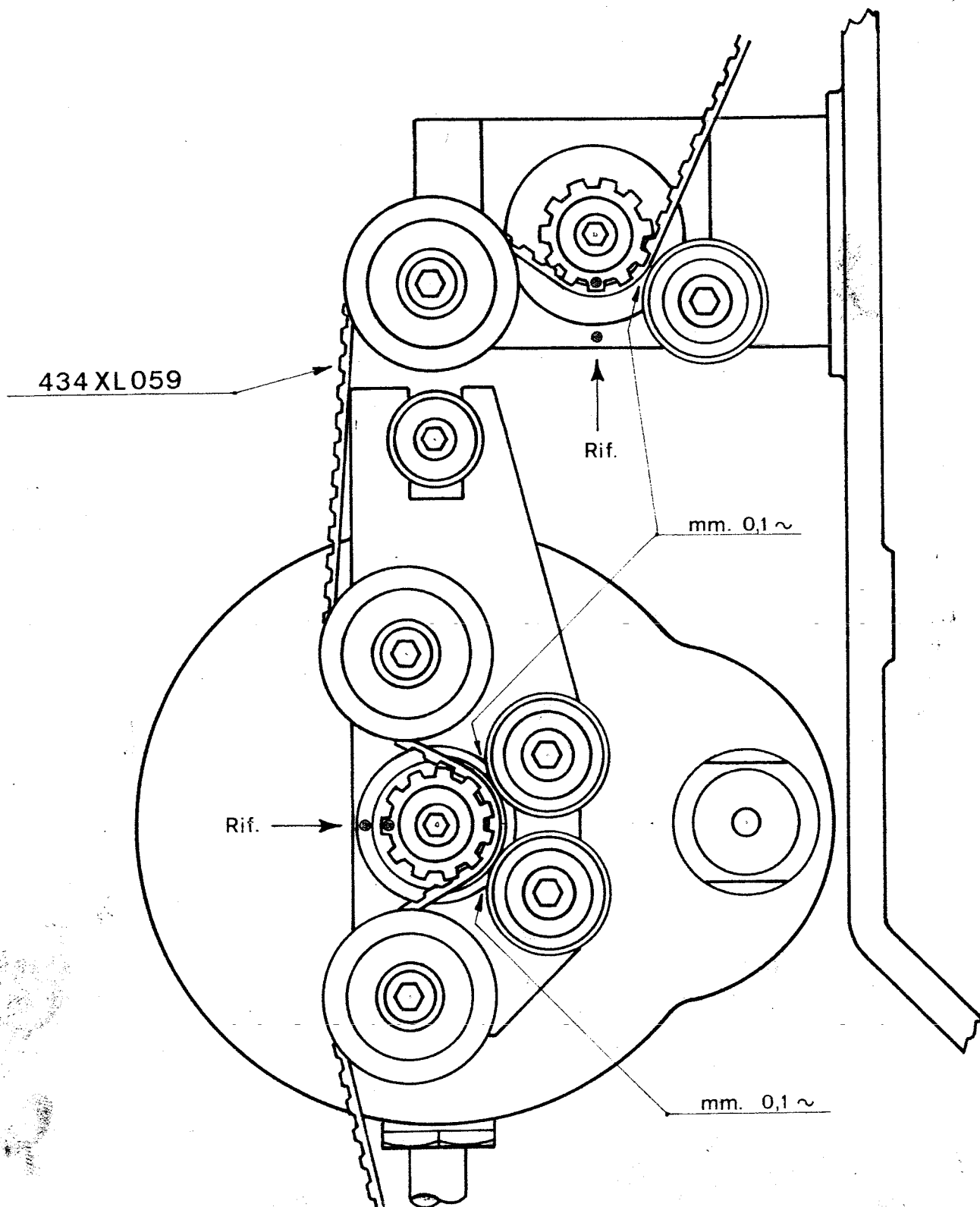

RIFERIMENTO FASE

In caso di cambio della cinghia assicurarsi che i punti di riferimento segnati in rosso coincidano e che il tratto di cinghia fra i due pignoni sia ben teso.

PHASE REFERENCE

when belt is replaced make shure to have the reference points

Data 15-1-75

Modifiche

Con compensatore idraulico
Avec compensateur hydrauliques
With dash pot

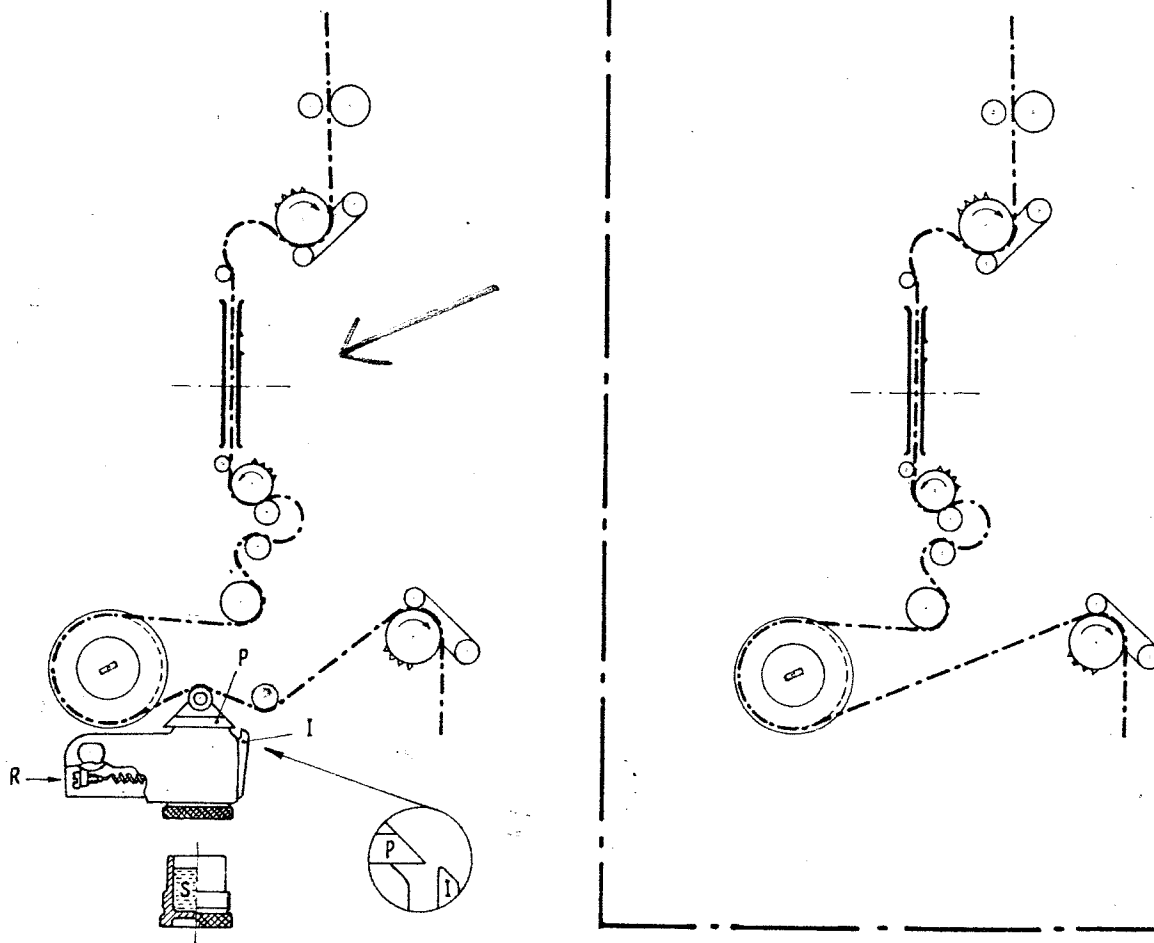

RIEMPIMENTO - Svitare il bicchierino, riempirlo di liquido S sino ad un centimetro dal bordo e riavitarlo in sede.

REGOLAZIONE - Montare il film e mettere in moto il proiettore, ruotare la vite R sino a che il bordo inferiore di P coincida con l'indice I.

REMPLISSAGE - Dévisser le godet, et le remplir de liquide S jusqu'à 1 cm. du bord supérieur.

REGLAGE - Une fois le film monté et avec le projecteur en marche, tourner la vis R jusqu'à ce que le bord inférieur du support P vienne à coïncider avec l'index I.

FILLING - Unscrew the pot, fill it with fluid " type S " till 1" from the rim then put back in.

DASH POT ADJUSTMENT - Thread the film and, while the mechanism is running, rotate the screw R until the bottom edge of P corresponds to the pointer I.