

Film-Tech

The information contained in this Adobe Acrobat pdf file is provided at your own risk and good judgment.

These manuals are designed to facilitate the exchange of information related to cinema projection and film handling, with no warranties nor obligations from the authors, for qualified field service engineers.

If you are not a qualified technician, please make no adjustments to anything you may read about in these Adobe manual downloads.

www.film-tech.com



ADVANCED TECHNOLOGY ANALOG SYSTEMS

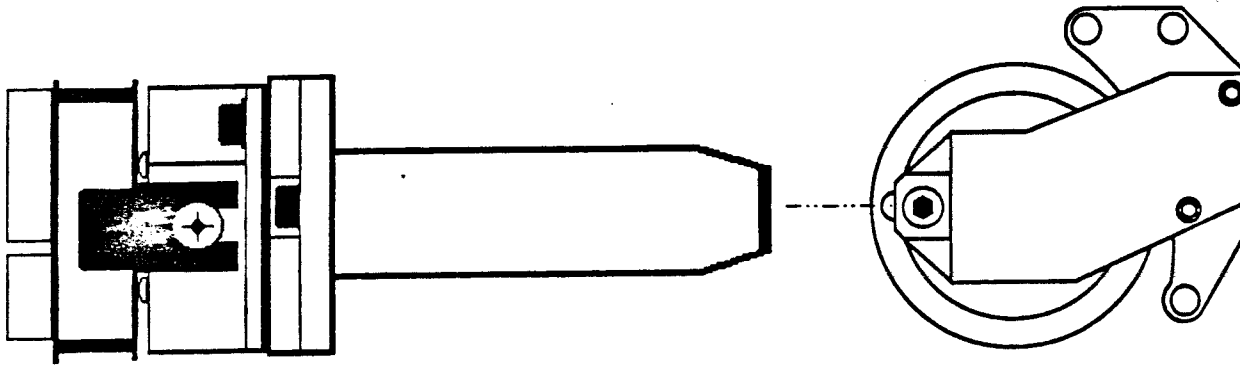

Conventional exciter lamps and their associated optical barrels were designed to reproduce monophonic tracks. The outstanding performance of current multi channel systems is limited by the inherent flaws of these components.

Kelmar Advanced Technology systems contain an integrated suite of solid state components developed by Dolby Laboratories Inc. They deliver a quality of analog optical stereo unattainable with conventional hardware. Crosstalk is eliminated and frequency response is flat to 16 KHz. The solid state light source is conservatively rated for 15,000 hours of operation. The optical assembly features independent, non-interactive adjustments for focus, vertical, lateral and azimuth settings.

Direct replacement retrofit systems are available for Century, Simplex, RCA, and Ballantyne optical reproducers. Field installation is straightforward and standard set-up procedures will hold for the life of the system.

The modest initial cost of the system, coupled with its freedom from repeated exciter lamp replacement and front end alignment costs, ensures a rapid and ongoing return on investment.

 **Kelmar Systems Inc.**

284 Broadway
Huntington Station
New York 11746 U.S.A.
(516) 421-1230 • (516) 692-6131
Fax: (516) 421-1274

AT-1200 REVERSE SCAN SOUNDHEAD CONVERSION KIT

This Kit contains the following:

- (1) IR LED Assembly with Cable
- (1) Solar Cell and Lens Assy.
- (1) IR LED / Pre-Amp Integrated Power Supply.

Items required for Installation:

Tools: Standard Allen Wrenche Set
Test Equipment : Real Time Analyzer
Dual Trace Oscilloscope
Multimeter
Test Films: SMPTE Buzz Track
Dolby Cat.69,97, and 566

Installation Instructions:

1) Remove the following items from the Soundhead.

- A) Solar Cell
- B) Exciter Lamp Assembly
- C) Sound Lens

2) Install the following items in the Sound Head.

- A) IR LED Assembly in place of old Solar Cell.
*** IMPORTANT Place the LED as close as possible to the Film ***
the distance should be about .040"
- B) Solar Cell and Lens Assembly in place of old Sound Lens.
*** See Page marked "Installation Notes" for your particular ***
application.

3) Mount the Integrated Power Supply as close as Possible to the Projector ie: Console Bulkhead under Projector or a Rack Mount kit is available.

4) Connect the Power Supply per the AT-1200 Block Diagram.

5) Connect the Solar Cell Pre-Amp Board to Sound Processor.

PLEASE NOTE THIS SYSTEM HAS BEEN FACTORY ALIGNED AND PERFORMANCE TESTED AND SHOULD ONLY REQUIRE MINIMAL ADJUSTMENT.

Alignment:

1) Preliminary

- a) Verify that the lens is clean.
- b) Verify that the LED is operational by doing a voltage check at the Power Supply, Voltage reading should be about 1.7 to 1.8 VDC. A reading of 5 VDC means the LED is not Operational.
- b) Verify the Cell wiring for proper left/right wiring to Sound Processor.

Primary

- 1) On the Optical Pre-Amp of the Cinema Processor, turn all of the Proj.1 and Proj.2 GAIN potentiometers fully clockwise (cw) or to the maximum gain settings.
- 2) On the Optical Pre-Amp of the Cinema Processor, turn all of the Proj.1 and Proj.2 HF potentiometers fully counterclockwise (ccw) or to the minimum gain settings.
- 3) Set the Cinema Processor to Mono Optical Sound Format.
- 4) Connect the RTA and Oscilloscope to the Left and Right Test Points of the Cinema Processors Optical Pre-Amp. Ground both instruments to GND Point on this board.
- 5) Thread and play the Dolby tone side of the Cat.69 test film for an initial test of the signal path through the Projector Preamplifier. The film emulsion should face away from the screen. At this point loosen the LED ARM mounting screws and move the arm up and down until you get the maximum output from the Solarcell, tighten screws down. Adjust the Proj.1 and Proj.2 gain potentiometers until the Noise Reduction Modules meters indicate proper Dolby level. In addition, verify that the signal present LEDs on the Optical Pre-amp are lit. The Dolby tone should be present on the Oscilloscope.
- 6) Remove the Cat.69 test film and thread SMPTE Buzz Track test film. Adjust the lateral guide roller so that no signal is present on the oscilloscope, if necessary the solar cell lateral position can be adjusted on the unit by loosening the Lateral position lock screw, and then adjusting the Lateral Carrier. When adjustment is done retighten the Lock screw. If signal is still present adjust the image size on the solar cell by unscrewing the front Lens Assy. a little bit at a time.
- 7) Remove the SMPTE Buzz Track test film and thread and play Dolby Cat.97 Stereo Cell Alignment Film. While the film is playing, look at the oscilloscope. If a large amount of crosstalk is present, move the lateral adjustment until the crosstalk both Left to Right and Right to Left are at a minimum and equal. You should be able to obtain better than 30dB of crosstalk (or better) rejection. Lock the adjustment in place.
- 8) Verify that the outputs of the Pre-amp are properly connected. To do this slowly insert a white card in front of the LED, as the card is inserted the Right Channel should drop out first.
- 9) Remove the Cat.97 test film and thread and play the pink noise side of the Cat.69 test film (emulsion side away from the screen) Connect the RTA to the Left test point on the optical Pre-amp in the Cinema Processor. Switch the Oscilloscope to the X/Y mode and adjust the azimuth of the Projector optics for the narrowest diagonal trace on the Scopes display.

- 10) While observing the trace on the RTA, Adjust the focus of the sound lens assy. for the best possible freq. response. The focus and azimuth may interact so after focus is set and azimuth has been set tighten the lens clamp screw on the Soundhead.
- 11) Disconnect the RTA from the Left test point and connect to the Right test point and verify that the output is similar to that of the Left channel.
- 12) Reconnect the RTA to the Left channel. Adjust the Left hf potentiometer on the Optical pre-amp to obtain a frequency response that is flat within 1dB to at least 16kHz.
- 13) Repeat step 12 for the Right Channel.
- 14) Remove the Cat.69 Test Film and thread and play Cat.599 Illumination Uniformity Test Film. Combine Left and Right channels on the Optical Pre-amp for a summed output to the RTA input. All 6 frequencies should be within .25dB of each other.
- 15) Remove the Cat.599 Test Film and thread and play Cat.69 Dolby Tone Test Film. Verify that the Optical Pre-amp is set at Dolby level.
- 16) Recheck Buzz Track, Cat.97 Crosstalk, and Cat.69 Pink Noise.

If further assistance is required contact:

Kelmar Systems Inc.
284 Broadway
Huntington Station, NY 11746
Phone 516-421-1230
Fax 516-421-1274

AT-1200 REVERSE SCAN SOUNDHEAD CONVERSION KIT

* INSTALLATION NOTES *

CENTURY SOUNDHEAD

To insure proper Lens Tube travel for Focusing of Solar cell Assembly. It may be necessary to remove some of the back portion of the Sound Lens Mounting Bracket. This is due to excessive material in some models.

SIMPLEX SOUNDHEAD

In older model Soundheads that used a Bausch and Lomb TU-30 Soundlens. It may be necessary to build up the new Lens Tube Assembly with either Hard Paper or Cue Foil. This was due to the TU-30 Soundlens having a O.D. of .750" as opposed to newer Lens having a O.D. of .747".

RCA SOUNDHEAD

A sleeve has been placed on the Lens Tube Assembly to increase its' O.D.. So proper clamping may be achieved.

Replacement Parts List
=====

P/N	DESCRIPTION
AT655CA	; Solar Cell & Pre-amp Bd.
ATIRLED	; IR LED
ATPS-5/12	; LED and Pre-Amp ; Power Supply Board
ATLENS18.5	; Lens

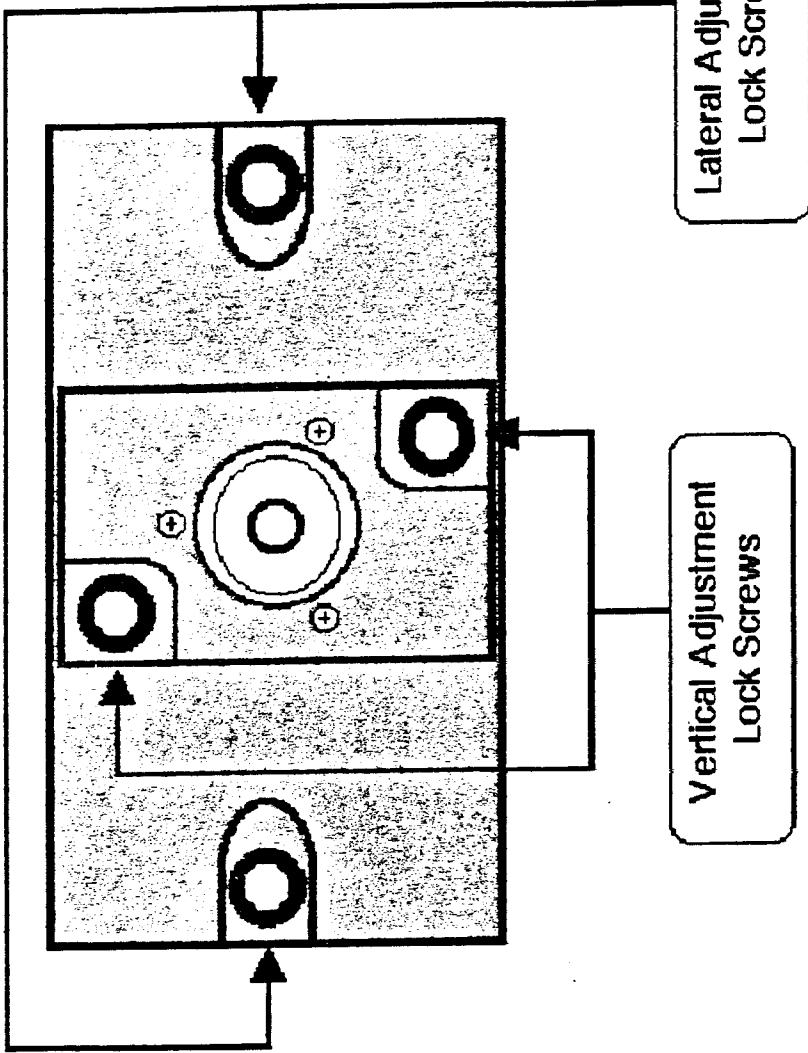

Lateral Adjustment
Lock Screws

Vertical Adjustment
Lock Screws

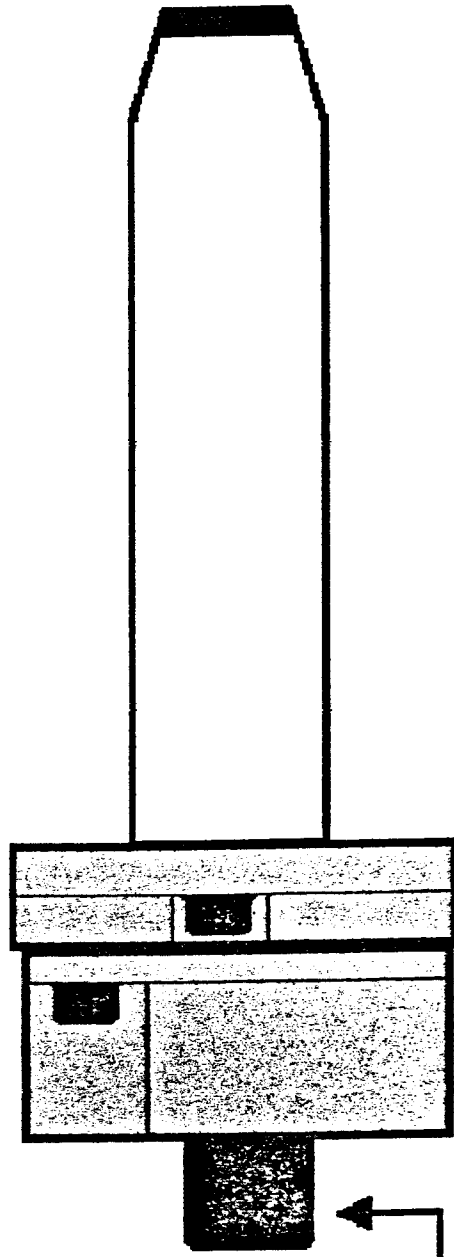

Solar Cell
Retaining
Bushing

Solar Cell Pre-Amp and Mounting Assembly

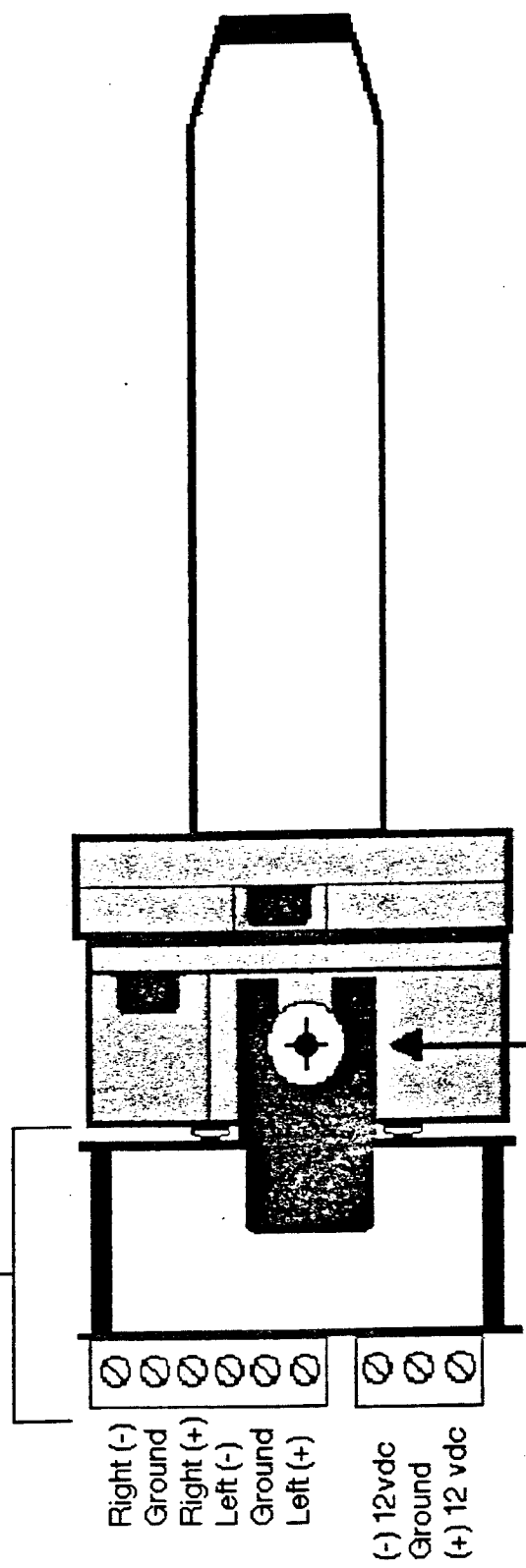

To make Lateral and Vertical Adjustments to this unit, loosen this screw and remove the Solar Cell Pre-Amp assembly.

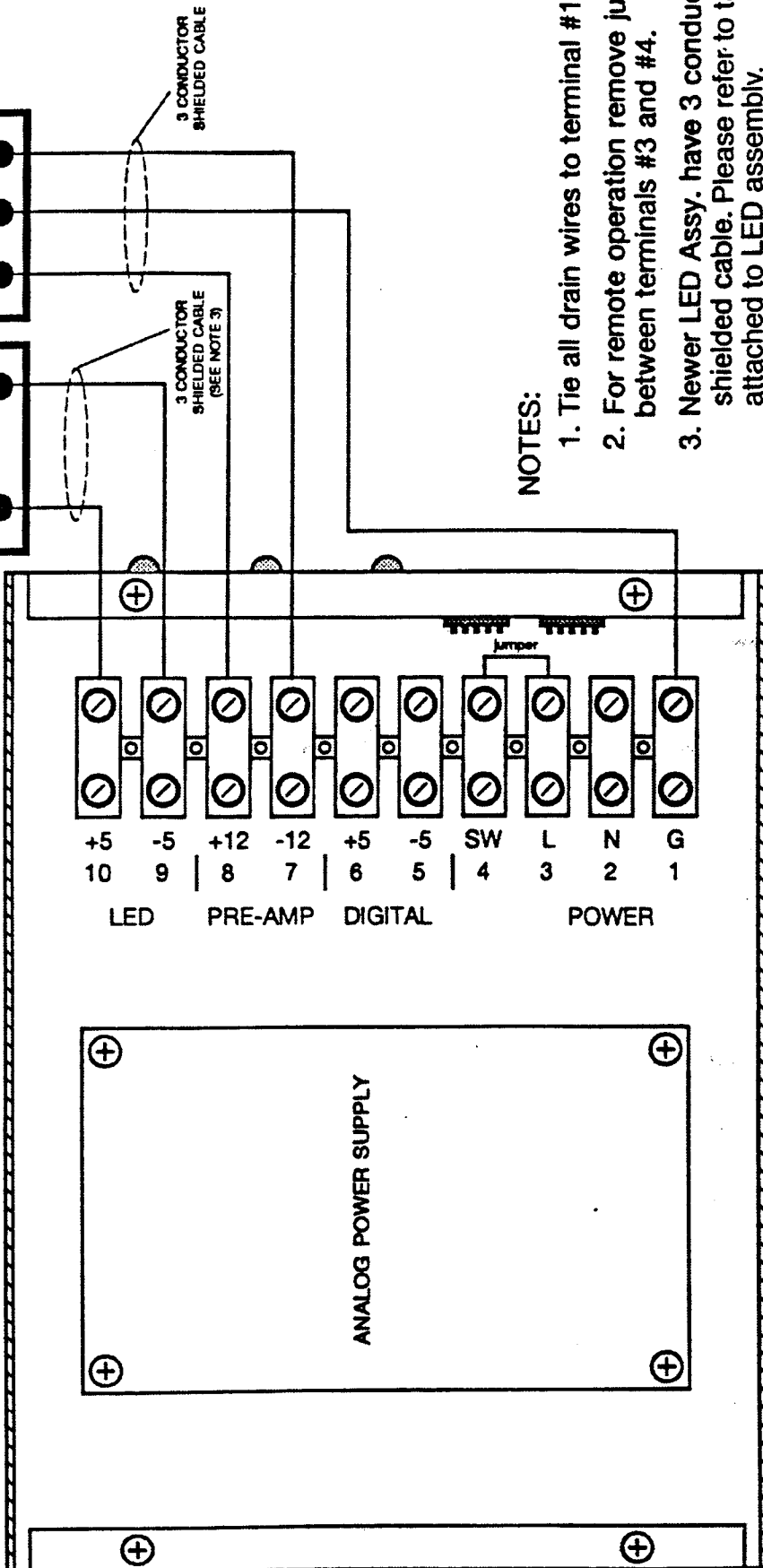
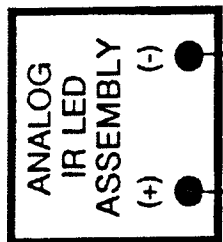
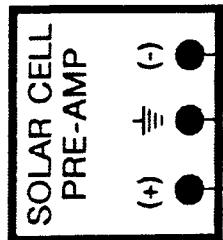

NOTES:

1. Tie all drain wires to terminal #1.
2. For remote operation remove jumper between terminals #3 and #4.
3. Newer LED Assy. have 3 conductor shielded cable. Please refer to tag attached to LED assembly.

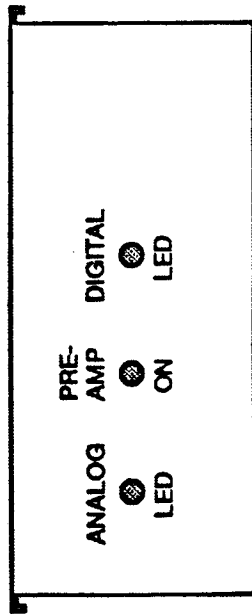

FRONT PANEL DETAIL

KELMAR AT 1200
DUAL POWER SUPPLY - BLOCK DIAGRAM

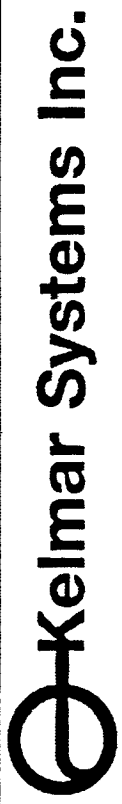

284 Broadway • Huntington Station • New York 11746 • 516-682-6131

PC 7929
IR Solar Cell
PreAmp Board

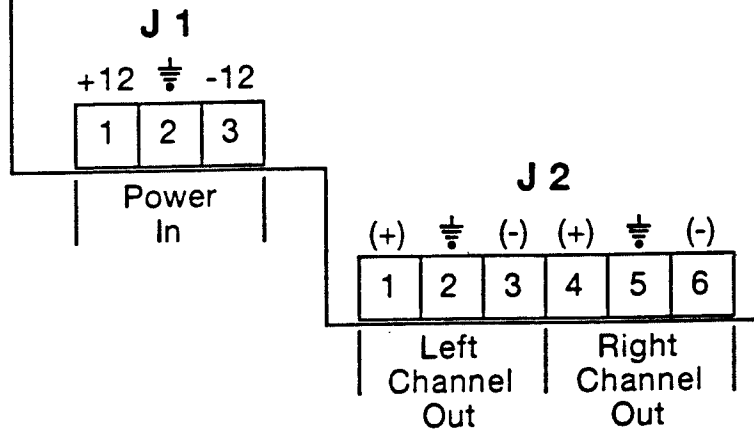

KELMAR PC 7929 AT-1200 SOLAR CELL
PreAmp Terminations

 **Kelmar Systems Inc.**

284 Broadway • Huntington Station • New York 11746 • 516-692-6131

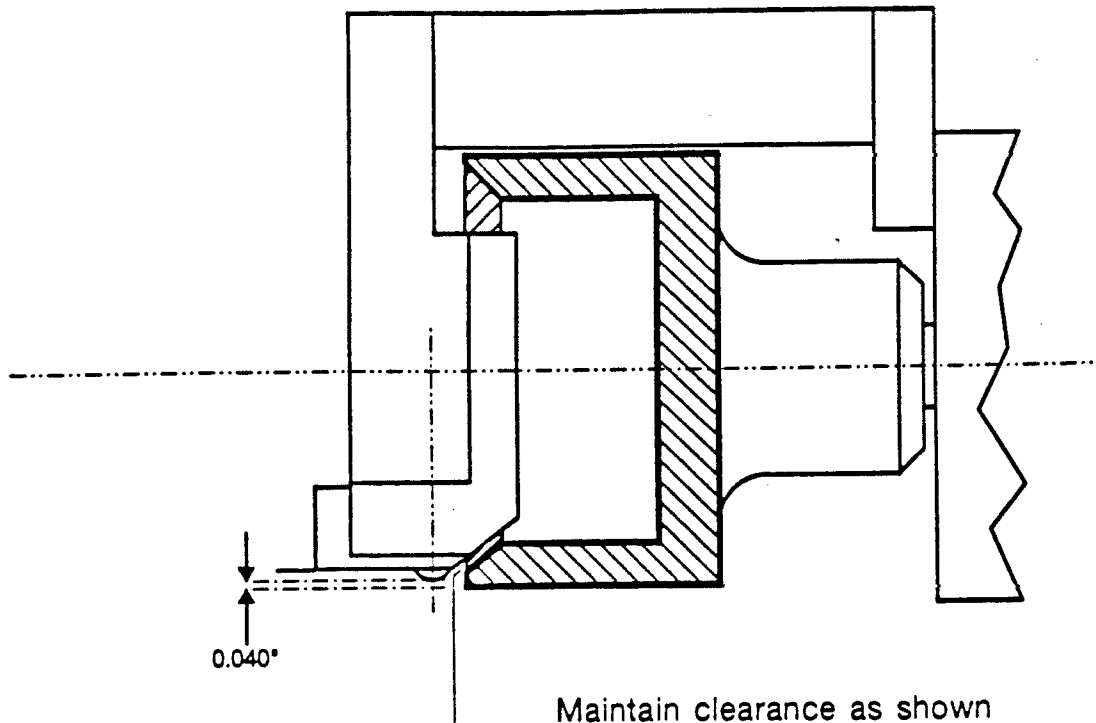

Maintain clearance as shown
 Note: Early RCA drums may
 require machining

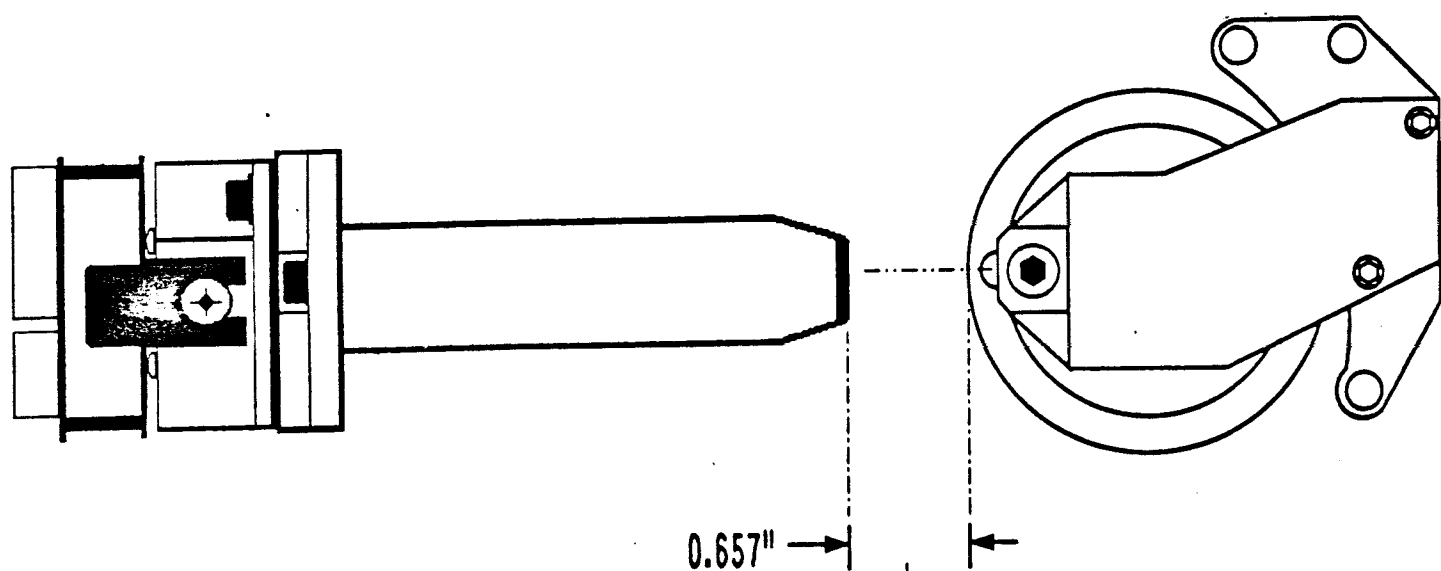

Initial setting of
 Optical Barrel .657" to film plane

**KELMAR AT 1200
 SCANNING DRUM DETAIL**

 **Kelmar Systems Inc.**
 284 Broadway □ Huntington Station □ New York 11746 □ 516-692-6131