

Film-Tech

The information contained in this Adobe Acrobat pdf file is provided at your own risk and good judgment.

These manuals are designed to facilitate the exchange of information related to cinema projection and film handling, with no warranties nor obligations from the authors, for qualified field service engineers.

If you are not a qualified technician, please make no adjustments to anything you may read about in these Adobe manual downloads.

www.film-tech.com

EQUIPMENT INSTRUCTION - SH-1000 SOUND MECHANISM (60 CYCLES & DC)
SH-1001 SOUND MECHANISM (50 CYCLES)

1. DESCRIPTION.

The SH-1000 (SH-1001) is a film propulsion mechanism for the reproduction of sound from 35mm sound film by the photo-electric cell method. It reproduces from single track sound film, details included herein, or from either single track or push-pull sound film when equipped with the SH-106 Push-Pull Kit. This kit is furnished separately - refer to Equipment Instruction "SH-106 Push-Pull Kit" for details. A motor assembly (SH-2053, 60 cycles; SH-2062, 50 cycles; SH-2063, DC), furnished separately, is required to drive the mechanism. The complete unit is 11-5/8" high x 27-3/8" long x 14" deep and weighs 110 lbs.

The mechanism is attached to the sound head support arm mounted on the projector pedestal. The motor assembly, including a motor and flywheel, flywheel guard and hand brake on a bracket, is attached to the front of the sound mechanism, and drives the projector mechanism and the constant speed sound and hold-back sprockets in the mechanism through a reduction gear box. The gear box may be removed as a unit. The hand brake, which engages the flywheel, is provided to stop the mechanism in case of film breakage. The take-up is driven from the mechanism. Belt drive is standard, but chain drive may be obtained.

At the rear of the mechanism is the scanning system. It is assembled on a bracket attached to the sound mechanism by a special vibrationless mounting. The well known rotary stabilizer maintains constant film speed past the scanning beam. A prefocused exciter lamp on an adjustable bracket provides an intense source of light to illuminate the .0012" slit in the optical system. Light from the optical system passes through the film sound track, and is reflected to the photo-electrical cell by an adjustable lens mirror. The vertically mounted photo-electrical cell and wirings are shielded from oil leakage and static pick-up.

Noise level - 35 db or better, flutter .15%, as measured on an ERPI Flutter Bridge, maximum weave $\pm .001$ ", pick-up time 2 - 3 seconds.

PEC polarizing potential and exciter lamp supply are obtained from separate sources.

2. DRIVE MOTOR.

Motors operating on power supplies of 105 - 125 volts AC., 50 or 60 cycles $\pm 3\%$ or 105 - 125 volts DC are available. A 5 ampere fusetron is recommended for each motor circuit. If fusetrans are not available, a 20 ampere fuse may be used temporarily.

3. INSTALLATION.

Remove all existing equipment from the projector pedestals, and install the sound head supports supplied with the system (See table).

<u>Pedestal</u>	<u>Sound Head Support</u>
"L"	SN-483
"R" or "M"	SN-484
Super Simplex	S-1183-L (Up to 20°) OR
or SI	S-1244-L (Above 20°)

Clean all parts of the sound mechanism carefully and install as follows:-

A. Main Frame Assembly. Bolt to the sound head support with four SN-476 Screws (3/8-16 x 1-1/4") and SN-477 Washers. Insert two upper bolts, hang assembly in slotted holes in support and thread in two lower bolts.

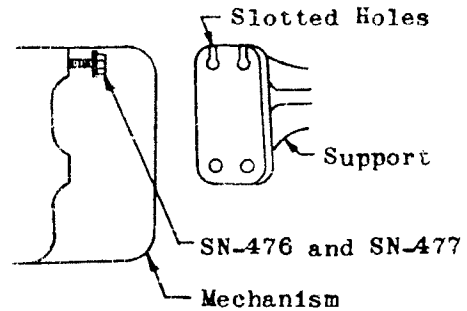

B. Motor Assembly. The motor and flywheel, motor switch box, attached to the motor by flexible conduit, and flywheel guard are shipped mounted on the motor bracket. Remove the motor, motor switch and flywheel guard from the bracket, and mount the bracket on the front of the sound mechanism with four SN-424 Screws (5/16-18 x 3/4"). Mount motor, motor switch and flywheel guard. In assembly the motor shaft slides into the flexible coupling on the gear box drive shaft, the motor is positioned laterally so that it lines up with the coupling, the mounting bolts tightened and the Allen set screws in the coupling tightened.

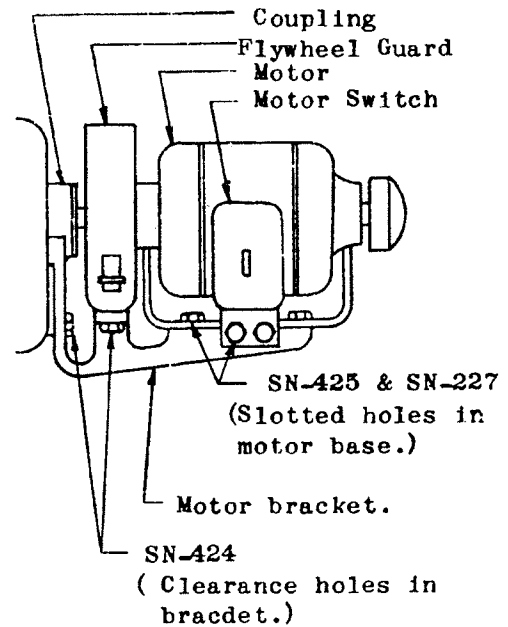

NOTE:- Slotted holes are provided in the motor base and clearance holes in the motor bracket for alignment purposes. For lateral alignment, loosen the motor mounting bolts and shift the motor horizontally. For vertical alignment, loosen the motor bracket mounting bolts and adjust the vertical position of the bracket.

C. Flywheel Guard and Brake. For installation, remove the brake from the guard by loosening the set screw and driving out the pin. To remove the guard from the motor bracket, withdraw the two SN-424 Screws (5/16-18 x 3/4"). To reassemble the guard and brake, the procedure is reversed.

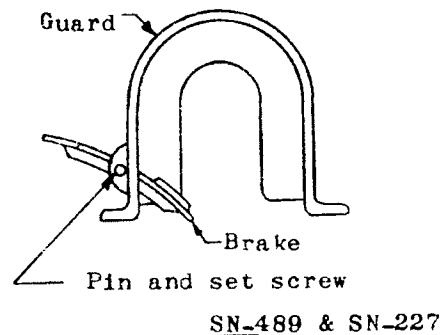

D. Lower Magazine. Bolt the lower magazine and SN-431 Cable Clamp Bracket to the bottom of the sound mechanism, using two SN-489 Screws (5/16-18 x 7/8") and SN-227 Washers. The contractor should furnish the cable clamps and should clamp the cables securely so that they do not contact the take-up drive belt.

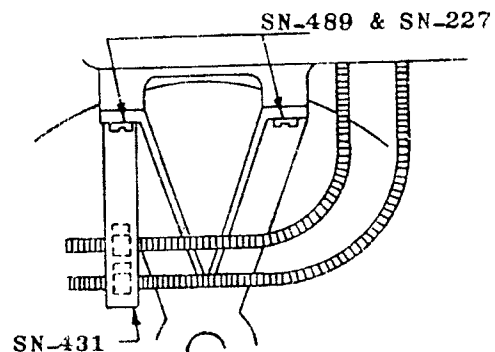

E. Take-up Belt. Adjust length as required and assemble. The take-up is driven from the sound mechanism.

F. Projector Mechanism is installed as follows:-

- (1) Remove the blue guard on the non-operating side of the sound mechanism, and the bar on the top of the mechanism as a unit, by taking out the screw on the side of the mechanism and the two SN-222 Screws (5/16-18 x 1") and SN-227 Washers fastening the bar to the mechanism.
- (2) Detach the blue guard from the bar. Save the two SN-230 Screws (3/8-16 x 5/8") as they are used to bolt the bar to the projector mechanism. The blue guard is provided only to protect the rotary stabilizer shaft from damage during shipment, and should be discarded.
- (3) Fasten the oil shield and bar to the mechanism with the two SN-230 Screws. "F" on the bar should be at the front.

NOTE:- The SN-475 Oil Shield is used with Regular Super Simplex and E-7 Projector Mechanisms. The SN-493 Oil Shield is used with Model SI Mechanism.

- (4) Mount the projector mechanism oil shield and bar assembly on the sound mechanism with two SN-222 Screws and SN-227 Washers through the slotted holes in the bar. Be sure that the SN-231 Screw, on the front of the mechanism, is threaded all the way in for clearance in mounting the drive gear.
- (5) Install the drive gear and stud supplied with the system (See table).

<u>Mechanism</u>	<u>Drive Gear</u>	<u>Stud</u>
Regular	SH-2005	SH-2007
Super Simplex	SH-2005	SH-2007
E-7 or SI	SH-2060	SH-2008

- (6) Turn the adjusting screw on the front of the mechanism so that proper mesh is obtained between the drive and driven gears. Tighten the lock nut and mounting bolts.

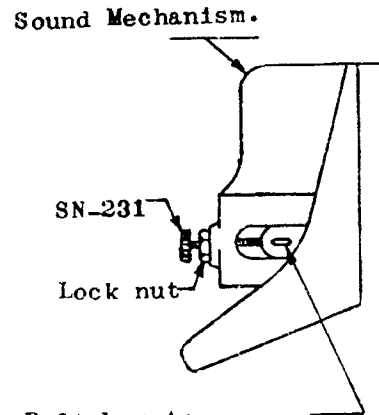
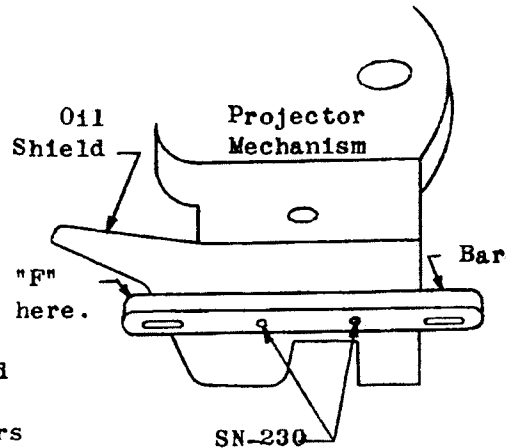
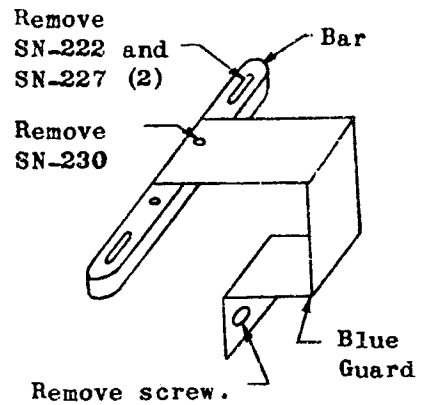

Bolt bar to Mechanism with SN-222 & SN-227

- G. Upper Magazine. Bolt to the top of the projector mechanism.
- H. Conduit Connections to Sound Mechanism. The coaxial cable should be installed in accordance with the equipment instruction packed with the cable. Flexible conduits should be installed and connected in accordance with the system wiring diagram. Be sure that the threads in the holes in the sound mechanism are clean so that the flexible conduit connectors make good contact when threaded into the holes.
- I. Damping Wheel. The SH-2026 Damping Wheel is shipped separately, and should be unpacked, handled and installed carefully to prevent damage. The following installation procedure should be followed carefully in order to insure proper installation and operation of the damping wheel, especially with regard to end play. Too much end play will cause weaving of the scanner drum and result in sprocket hole and frame line noise.

- (1) Remove the SN-357 Screw and nut from the drum shaft on the non-operating side of the sound mechanism. The two loose spring washers on the shaft should not be removed.
- (2) Unpack the damping wheel carefully, and make sure that all foreign material is removed from the mounting hole.

- (3) Slide the damping wheel carefully onto the shaft while holding the scanner drum (operating side of Mechanism) against its shoulder. Line up the mounting holes in the shaft and wheel, insert the screw, removed under (1) above, in the counter-bored hole in flange and tighten securely so that the slotted flange is clamped to the drum shaft. The nut removed under (1) above is not used.

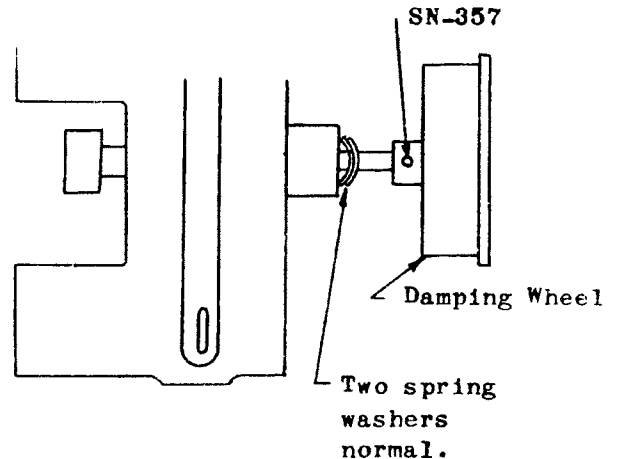

- (4) Check the assembly for end play: The spring washers should hold the scanner drum firmly against its shoulder - that is, the spring washers should be under compression at all times. Therefore, push the stabilizer drum carefully toward the operating side as far as it will go and release it. If the scanner drum does not return and seat firmly against its shoulder, there is too much end play. The damping wheel should then be removed, and one of the spring washers reversed. This will increase the effectiveness of the washers and should give the proper amount of end play.

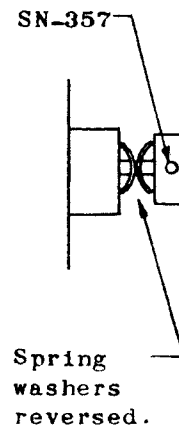

- J. Rear Guard. Attach to the non-operating side of the main frame assembly tightening the thumb screws securely.

K. Install the exciter lamp and photo-electric cell supplied with the system.

SN-297 Exciter Lamp (4 amps, 9 volts) - Systems having PU-1000 Power Unit.

SN-299 Exciter Lamp (7½ amps, 10 volts) - Systems having PU-1005 Power Unit.

L. Fill the gear box on the non-operating side slowly with SAE #40 Oil (1-1/2 ounces required) to the red line of the sight glass while the mechanism is idle.

CAUTION:- Do not add oil while the mechanism is running. Oil taken up by the running gears will drain into the bottom of the gear box when the mechanism is idle. The oil level will then be too high and leakage may occur around the bearings, especially with large projection angles.

Oil leakage around the bearings may be due to clogged oil return holes in the gear box casting, preventing oil thrown on the bearings from returning to the gear box. If such a condition is encountered (with correct oil level in the gear box) the gear box should be taken out of the sound mechanism, the retainer ring removed from each bearing and the oil return hole carefully cleaned with a toothpick or similar device by pushing the grease deposit down into the gear box.

M. Adjustment of Scanning System. The main frame assembly is shipped with the exciter lamp bracket, lens tube, lateral guide roller and reflector lens mounted and adjusted ready for use. It is recommended, however, that the adjustments be checked. Use the Academy Buzz Track Film to check the adjustment of the lateral guide roller. Use the Academy Standard Scanning Illumination Test Track to check the exciter lamp adjustment and for final precise adjustments of the lateral guide roller. See attached Supplement "Standard Scanning Illumination Test Track" for application in Simplex Sound Systems. The lens tube adjustment should be checked, using the Academy 7,000 Cycle or 9,000 Cycle Film or ED-20 Test Film.

Refer to the Tuning-Up Instruction (included in the Instruction Book shipped with the system) for temporary changes in the warping circuit to increase high frequency response. The adjustment procedure for each of the above units is given below. Before proceeding, however, it is extremely important that the exciter lamp, photo-electric cell and lenses be thoroughly cleaned with lens tissue, and all parts of the sound mechanism cleaned with a soft cloth. Refer to Equipment Instruction "SH-106 Push-Pull Kit" for adjustments of push-pull scanner system.

(1) Exciter Lamp Bracket. Vertical and lateral adjustment are provided for the prefocused base exciter lamp. For vertical adjustment, loosen the clamping screw on the left of the bracket, and adjust the vertical knurled screw at the bottom as required. For lateral adjustment a screw and lock nut are provided on the front of the bracket. To move the bracket inward, loosen the screw and slide the bracket in. To move the bracket outward, tighten the screw. After the adjustments have been completed, be sure that the clamping screw and nut are tight. Check the adjustment with the Academy Standard Scanning Illumination Test Track (See Supplement).

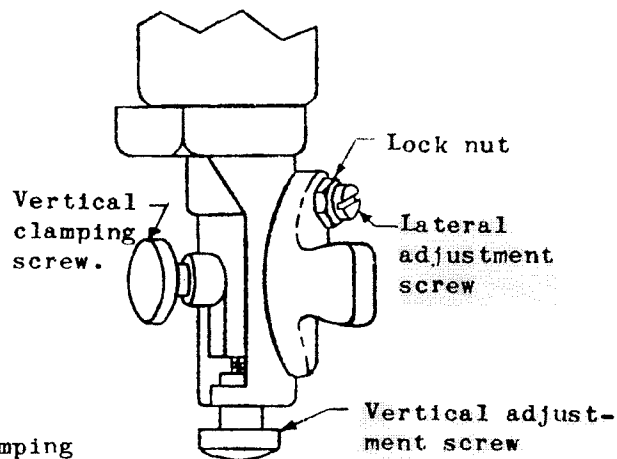

- (2) **Lens Tube.** The lens tube is accurately adjusted for azimuth and properly focused before shipment. The azimuth adjustment should not be disturbed. To focus the lens tube, loosen the clamping screw above the lens holder and turn the knurled adjusting nut below as required. Be sure the clamping screw is tightened after the adjustment has been completed. Two methods of adjustment, using the Academy 7,000 Cycle or 9,000 Cycle Test Film or ED-20 Test Film, may be used - the response test or flicker test.

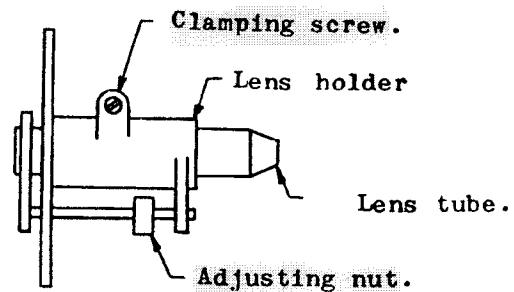

- (a) **Response Test.** Thread the machine with the test film, run the machine and adjust the lens tube for focus until maximum response is obtained on a volume indicator or aurally.
- (b) **Flicker Test.** Thread the machine with test film, place a white card between the film and reflector lens and turn the motor hand wheel slowly. The film frequency lines make a definite flicker of light on the card. The tube is focused when the lines are stationary. If they move downward on the card, the lens tube should be closer to the film - while if they move upward, the tube should be farther from the film.

- (3) **Reflector Lens (Single track film only)**
If properly adjusted the spot on the photo-electric cell should be about 7/16" in diameter and centered on the anode of the cell. To position the spot of light, loosen the clamping screw at the top of the lens holder and carefully rotate the lens until the spot is centered on the anode. To change the size of the spot, move the lens in or out of the bracket as required. If further movement is required, loosen the two lens holder mounting screws and adjust as necessary. Slotted holes are provided in the lens holder.

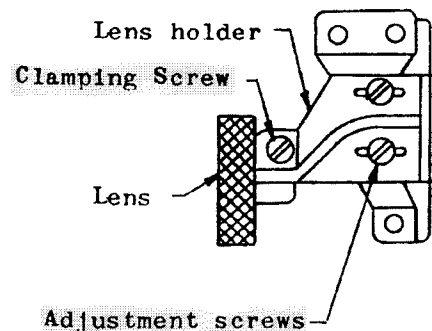

These adjustments are more readily made if the photo-electric cell is removed and a piece of transparent paper substituted. A still more convenient method is to remove the glass envelope and cathode from an old photo-electric cell, and substitute a transparent paper cathode attached to the cathode support wires. With either of these methods the spot can be accurately centered and adjusted for size.

- (4) **Pressure and Guide Roller.** To adjust, loosen the locking screw in the center of the knurled adjusting nut and turn the nut as required. Clockwise rotation moves the roller inward. Be sure that the spiral spring at the rear of the pressure and guide roller holds it firmly against the knurled adjusting nut at all times. When properly adjusted the scanning beam does not strike the frame lines or sprocket holes. Check the adjustment, using Academy Buzz Track Film, and make final precise adjustments with Academy Standard Illumination Test Track (See Supplement).

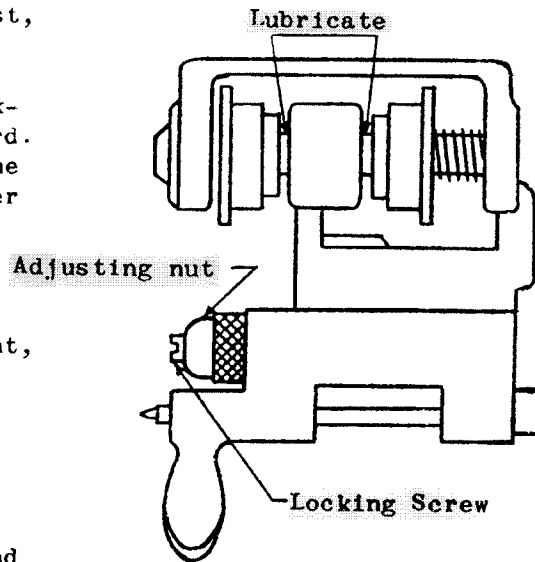

- (5) **Pad Rollers.** The clearance between the sound and hold-back sprockets and their pad rollers should be equal to two thicknesses of film. To adjust, loosen the fillister head clamping screw, insert two thicknesses of film between the roller(s) and sprocket, press the roller(s) firmly against the film and tighten the screw.

The roller(s) should rotate freely. To adjust, loosen the set screw at the top of the bracket, grasp the knurled roller stud, pull carefully until the roller rotates freely and tighten the clamping screw. Do not allow more clearance than is necessary for free rotation.

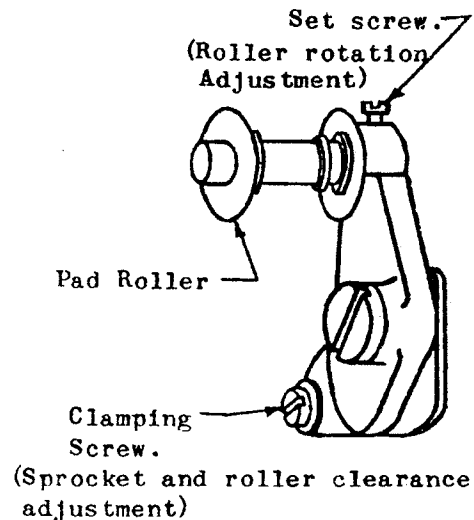

- (6) **Lubrication.** See Lubrication Chart.

- (7) **Threading Film in the Sound Mechanism.** Film should be threaded in the projector mechanism in accordance with the instructions furnished there with, and in the sound mechanism in accordance with the following sketch:-

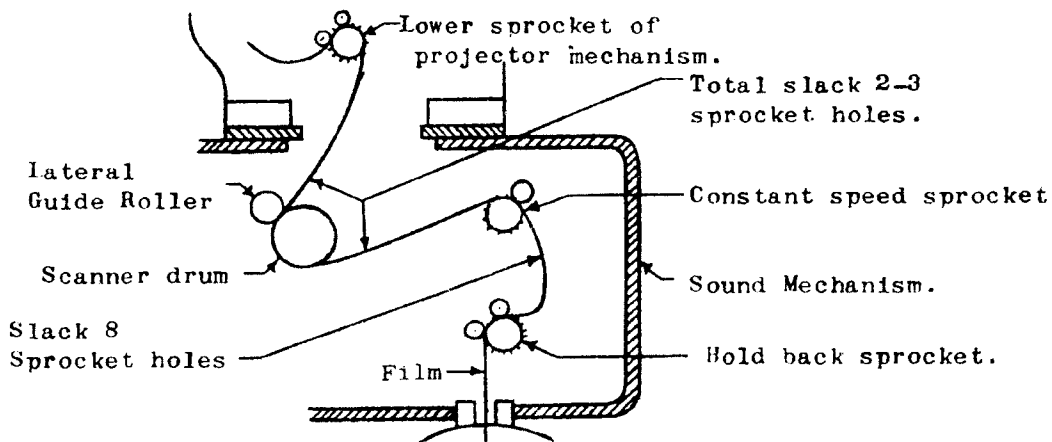

4. OPERATION.

- A. Lubrication. See Lubrication Chart.
- B. Clean the mechanism thoroughly each day. It is extremely important that all glassware, reflector lens and lens tube lenses be thoroughly cleaned with lens tissue as these surfaces accumulate particles, such as carbon dust, rapidly with resulting loss in gain.
- C. Sound Test. Sound should be checked daily before operating. As a preliminary sound test, move a card rapidly in and out of the light beam between the reflector lens and the photo-electric cell on each machine. A "thump" should be heard from the stage and monitor speakers. If possible a short standard reel should be run in each machine to test for sound quality and changeover.
- D. Threading the Mechanism. Thread the mechanism in accordance with the instruction in the previous section. The lateral guide roller must be closed after threading. If the sound mechanism door does not close, the guide roller is open.
- E. Lateral Guide Roller Assembly. Pull the guide roller assembly outward, after threading is completed and the roller is closed, until it is in firm contact with the knurled adjusting nut. There is a spring on the stud at the rear of the assembly to hold it firmly against the adjusting nut. In some instances, however, the assembly may be pushed inward as it is closed and may not return to its proper position due to friction. Sprocket hole noise will occur and cannot be remedied by adjustment.

If the assembly has an unusual tendency to stick, the following should improve the condition.

- (1) A drop of Simplex Oil should be applied on the supporting stud between the knurled nut and the assembly. Distribute the oil along the stud by pushing the assembly back and forth and opening and closing it several times. Wipe off all excess oil.
- (2) Increase the length of the spring at the rear of the assembly from $13/16$ " to $1-1/8$ ". The effectiveness of the spring will increase and will aid in returning the assembly to its proper position. To increase the length of the spring, remove the assembly and spring and stretch each spring coil carefully until the length is $1-1/8$ ". It is essential that the lengthening be done carefully so that the ends remain perpendicular to the axis of the spring.
- (3) In some of the earlier sound mechanisms the threads on the stud were over-size and may tend to cause the assembly to stick. The assembly should then be removed, and fine emery cloth used carefully on the threads only and not on the stud shaft. Clean all parts carefully.

Leave the guide roller open when there is no film in the mechanism. If it is left closed, flat spots will develop on the felt rollers, will cause flutter and make replacement necessary.

5. MAINTENANCE.

- A. Cleanliness cannot be emphasized too strongly. Oil, dirt and other foreign material in the mechanism will impair the quality of reproduction, increase wear and eventually cause interruptions in the show and increase in replacements. Careful cleaning and daily inspection, on the other hand, will insure continued uninterrupted high quality sound.
- B. The Exciter Lamp glass envelope blackens with age and the filament tends to sag. Both impair the quality and reduce the volume level. Lamps should, therefore, be inspected frequently and replaced before the condition becomes serious.
- C. Photo-electric Cell. The efficiency of the cell decreases with age resulting in a gradual decrease in output volume and frequency response. Cells should be replaced before quality is impaired.
- D. Lateral Guide Roller Assembly. Be sure that the guide roller is left open when there is no film in the mechanism. If left closed, flat spots will develop on the felt rollers, will cause flutter and make replacement necessary. The guide roller assembly must be removed to replace a felt roller.

(1) Removal and Reinstallation of Guide Roller Assembly.

- (a) Remove the exciter lamp bracket.
- (b) Remove the photo-electric cell and rear photo-electric cell shield.
- (c) Remove the two screws holding the partition plate in place and slide out the partition plate.
- (d) Remove the four screws mounting the entire optical system and lift out the optical system carefully.
- (e) Remove the lateral guide roller assembly by first loosening the locking screw in the center of the chromium plated adjusting nut, remove the adjusting nut and slide the entire assembly from the mounting stud. Be sure that the spring and steel washer back of the lateral guide roller assembly remain on the mounting stud.

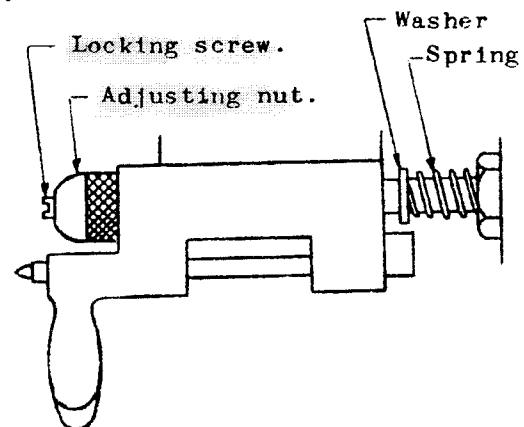
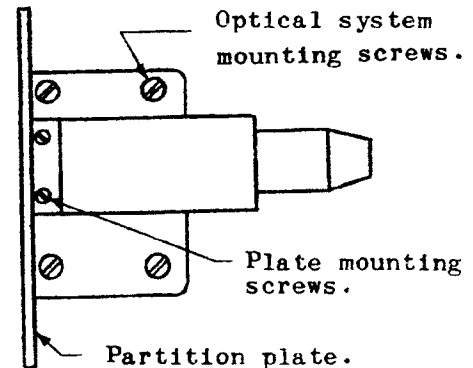

- (f) Reinstall the guide roller assembly and adjusting nut. Do not tighten the locking screw.
- (g) Reinstall the optical system, partition plate and exciter lamp bracket.

(h) By means of the adjusting nut locate the guide roller assembly laterally so that the scanning beam is properly positioned on the sound track, using buzz track and 17-position track film. If such film is not available, the adjustment may be made as follows:-

- (1) Thread regular release film in projector and sound mechanisms in the usual manner and start the machine.
- (2) Observe the position of the scanning beam with relation to the sound track. As an aid in observing the edges of the sound track, a flash light may be directed on the concave side of the film (that side in contact with the rotary stabilizer drum) and the image viewed from the same side of the film.

In making the above adjustments, be sure that the guide roller assembly is under tension - that is, that the spring on the mounting stud behind the guide roller assembly is functioning so that the guide roller assembly is in contact with the adjusting nut at all times.

While the removal and reinstallation of the optical system may not seriously affect the focus thereof, the focus should be checked with frequency film at the first opportunity.

NOTE:- Assemblies returned should be packed carefully to prevent damage during shipment. Each assembly should be carefully wrapped in clean paper so that packing material, such as excelsior or other foreign matter, does not reach the assembly or damage the felt roller.

(2) Replacement of Felt Roller.

- (a) Remove cover plate.
- (b) Remove screw under cover plate. Use two screw drivers, one to hold screw on other end of shaft.
- (c) Slide roller assembly as indicated in the sketch and remove the flange and felt roller.
- (d) Install new felt roller and assemble the unit.
- (e) Install the lateral guide roller assembly and adjust per the previous section.

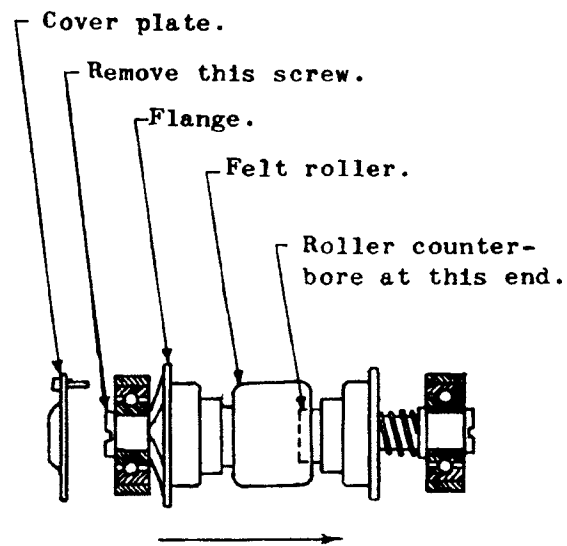

E. Lubrication. See Lubrication Chart.

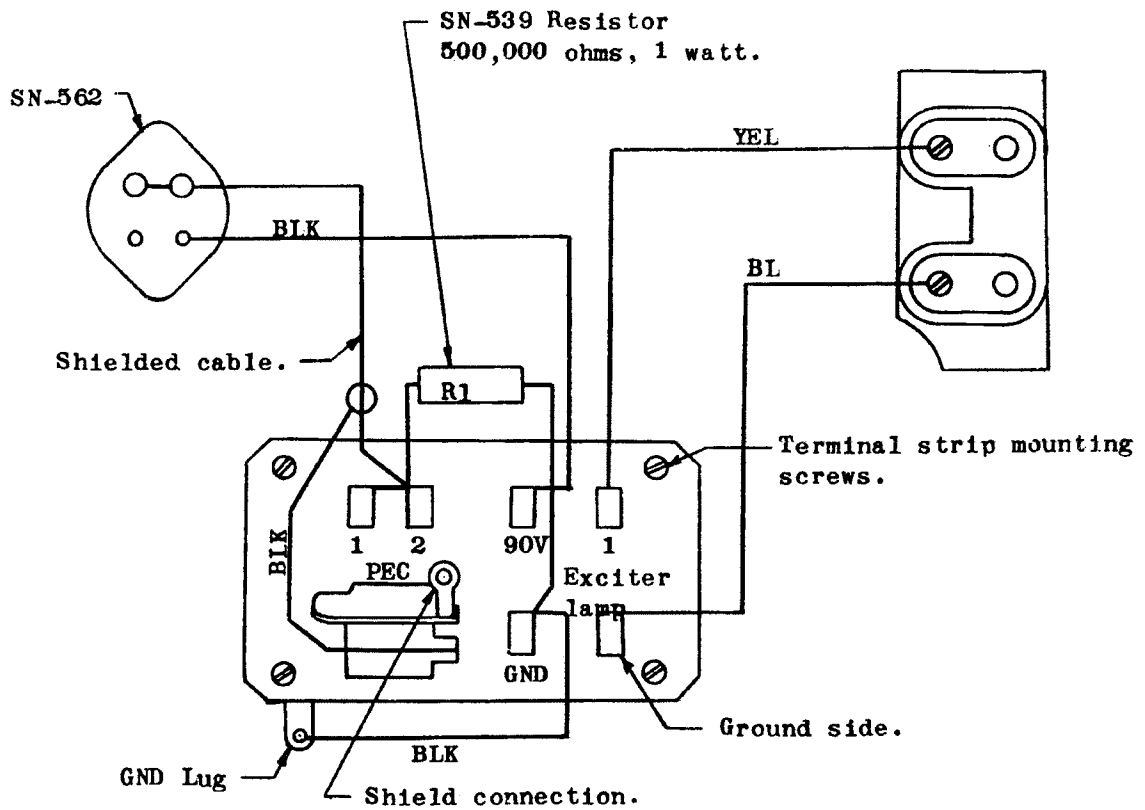

SN-297 Exciter Lamp (4 amp., 9 volts)
or
SN-299 Exciter Lamp (7.5 amp., 10 volts)

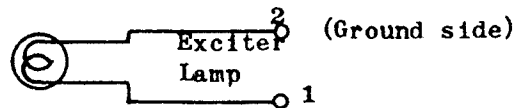

SN-724 Photo-electric Cell (Single track)

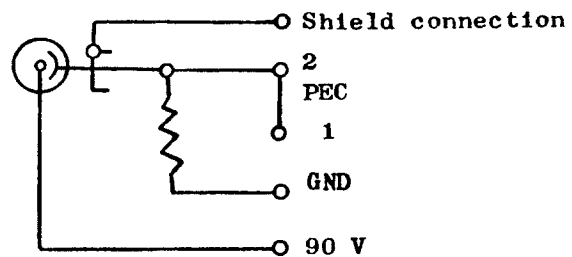

SH-1000, SH-1001 SOUND MECHANISM

WIRING DIAGRAM AND SCHEMATIC.

SUPPLEMENT TO

EQUIPMENT INSTRUCTION "SH-1000 (SH-1001) SOUND MECHANISM"
(Use of Standard Scanning Illumination Test Track)

1. DESCRIPTION.

The Standard Scanning Illumination Test Track, made available by the Academy of Motion Picture Arts and Sciences, affords an accurate means of checking the uniformity of illumination across the scanning slit and the adjustment of the lateral guide roller assembly in Simplex Sound Mechanisms to obtain uniform optimum sound track illumination. Uneven illumination distorts tone quality and may cause attenuation. The test track is a 230 foot length of 35mm film containing 17 approximately equally spaced 1000 cycle tracks, each with an amplitude of 6.8 mils $\pm 1.0\%$. Track #1 is on the outside nearest the sprocket holes, and track #17 on the inside toward the center of the film. The tracks are so placed longitudinally on the film that only one is scanned at a time, and each track is identified before scanning. Tracks #1, 2, 16 and 17 fall outside a correctly adjusted scanning system using an 84 mil slit, so that only tracks 3 to 15 inclusive will be reproduced at full output. The maximum allowable variation in output is 3 db, that is, a tolerance of ± 1.5 db.

2. PREPARATORY PROCEDURE.

In view of the precise adjustments obtainable with the Standard Scanning Illumination Test Track, it is desirable that preliminary tests and adjustments of the components be made before this test track is used. While the sound mechanism is carefully adjusted at the factory, the pertinent adjustments applying should be checked as noted below. The adjustment of the PU-1000 Power Unit is extremely important and should be carefully made.

- A. PU-1000 Power Unit. When this power unit is used the DC output should be carefully adjusted per Equipment Instruction "PU-1000 Power Unit" and the supplementary instruction "Adjustment of PU-1000 Power Unit" so that the current supplied to the "ON" exciter lamp is 4 amperes DC.
- B. PU-1005 Power Unit. When this power unit is used be sure the exciter lamp current is 7.0 amperes AC.
- C. Exciter Lamp. The exciter lamp in each sound mechanism should be adjusted per Equipment Instruction "SH-1000 (SH-1001) Sound Mechanism" so that the exciter lamp filament is centered horizontally and vertically on the slit in the lens tube.
- D. Optical System. The lens and reflector lens should be adjusted per Equipment Instruction "SH-1000 (SH-1001) Sound Mechanism". Adjustment of the lens tube should be made using the Academy 7000 or 9000 Cycle Film or ED-20 Test Film, and the warping circuit in the power amplifier changed temporarily during this adjustment in accordance with the Tuning-Up Instructions for the particular system.

Positioning the reflector lens as close as possible to the film without interfering with the scanning drum has usually been found to give the best performance. The spot of light on the cathode of the photo-electric cell should be properly centered, and when this spot is adjusted to its maximum diameter it usually covers the entire width of the cathode. The exciter lamp, lens tube lenses, reflector lens and photo-electric cell should be carefully cleaned with lens tissue.

- E. Lateral Guide Roller Assembly. Check the adjustment of the lateral guide roller assembly, run the Academy Buzz Track Film and adjust the roller as necessary per Equipment Instruction "SH-1000 (SH-1001) Sound Mechanism" to eliminate frame line and sprocket hole noise. Final precise adjustment of the guide roller should be made with Standard Scanning Illumination Test Track per Section 3.
- F. Photo-electric Cell. Be sure that normal PEC voltage is being supplied to each photo-electric cell and that the cell is firm in its socket. In systems using the AM-101 Volume Control Amplifier the voltage should be measured between the "PEC and "Ground" terminals of the AM-101. In the Type "E" System it should be measured between the "90 V" and "Ground" terminals of the AM-141 Volume Control Amplifier, the voltage supplied to the cells being adjustable, for output equalization, by a potentiometer connected between the "90 V" terminal and the photo-electric cells of the two machines. Voltage readings are tabulated below, the vacuum tube voltmeter reading being the actual voltage. The readings using the 1000 ohm per volt voltmeter are lower due to the extra current drain of the meter.

	SYSTEM		TYPE "E"
	A-15, A-30, B-30, B-60, C-60		
Vacuum tube voltmeter	84 volts		90 volts
1000 ohm per volt voltmeter, 100 volt scale	60 volts		65 volts

3. METHOD OF USE.

- A. Thread the Standard Scanning Illumination Test Track in the mechanism in the regular way.
- B. Connect a volume indicator across the output of the power amplifier (AM-1001 or AM-142) and disconnect the stage speakers. In systems having LU-1002, LU-1003, or LU-1026 Networks, the volume indicator should be plugged into the network panel jack, which is connected across the amplifier output. The stage speakers should be disconnected by setting the "HF" and "LF" switches on the network panel in the "OFF" position which properly terminates the amplifier for volume indicator measurements.

In the Type "E" System the stage speaker load should be disconnected from the AM-142 Amplifier by removing the amplifier output lead (blue wire) from the amplifier "Output" terminal. The volume indicator should be connected to the blue wire and "ground" terminal and a 12 ohm resistor of at least 10 watts capacity connected in parallel with the volume indicator to properly terminate the amplifier

- C. Run the test track and plot all volume indicator readings. If the maximum and minimum readings for tracks 3 to 15 inclusive differ by more than 3 db., lateral adjustment of the exciter lamp and or lateral guide roller assembly is necessary until these readings are within the limits specified above.

Uneven illumination, caused by lateral displacement of either the exciter lamp or lateral guide roller assembly from optimum position, or vertical displacement of the exciter lamp from optimum position, may cause distortion and decrease the output level. However, the optical system and exciter lamp used in Simplex Sound Mechanisms have been especially designed so that moderate displacement of the exciter lamp from optimum position has a minimum effect on illumination.

The prefocused base exciter lamp with its short, heavy, large diameter coiled filament accurately located in its glass envelope with respect to the skirt, gives a source of light which extends beyond the mechanical slit in the optical system. The type and accuracy of construction of the lamp, its positioning for optimum illumination and the type of optical system used give output uniformity without adjustment. As a refinement, however, lateral and vertical adjustments, which are easily and quickly made, have been provided

In the optical system used, the condenser lens forms an image of the light source in the objective lens, a mechanical slit is placed close to the condenser lens, and since the aperture of the condenser lens is circular the useful portion of the light source is limited in width to the diameter of the objective lens.

Other optical systems wherein the light source is imaged in the plane of the mechanical slit, which is in turn imaged on the film plane, or which consist of cylindrical lenses wherein the smaller dimension of the source is imaged directly on the film, exciter lamps of different design are necessary. In the former of these two optical systems the light source is of the same general proportions as the slit, and the vertical adjustment is extremely critical. In the latter case coil filaments of approximately the same proportions are used, but the diameter and horizontal alignment of the coil must be held to close limits for optimum results.

- D. If track 3 is below the lower limit, its illumination is inadequate and the exciter lamp bracket should be moved outward carefully and/or lateral guide roller assembly moved inward. Adjustments of both exciter lamp and lateral guide roller assembly should be made to be sure that the optimum position of both is obtained.
- E. If track 15 is below the lower limit, its illumination is inadequate and the exciter lamp bracket should be moved inward carefully and/or lateral guide roller assembly moved outward. Adjustments of both the exciter lamp and lateral guide roller assembly should be made to be sure that the optimum position of both is obtained.
- F. One of the middle tracks may occasionally be below the lower limit. If such a condition is encountered, the exciter lamp should be inspected carefully as a sagging filament is indicated. This condition is remote due to the comparatively short and heavy filament used in the Simplex exciter lamp, but may occur near the end of the life of the lamp.
- G. The above tests should be made on each machine and until all readings taken on tracks 3 to 15 inclusive are within the specified limits. This test track is an accurate means of adjustment, and extreme care should be taken in making the test and any necessary adjustments.

4. REFERENCES

- Equipment Instruction "PU-1000 Power Unit".
- Equipment Instruction "Adjustment of PU-1000 Power Unit" (Supplement to the above instruction).
- Equipment Instruction "SH-1000 (SH-1001) Sound Mechanism".
- Tuning-Up Instruction for Type "A-15", "A-30", "B-30", "B-60", "C-60", or "E"
System selected for the particular theatre.
- Journal of the Society of Motion Picture Engineers, July 1939, Page 80,
"Properties of Optical Systems for Sound Reproduction", F. E. Carlson.

Simplex ^{TRADE MARK} **★★★★** SOUND System

SOUND MECHANISM LUBRICATION CHART

DAILY

FILL OIL CUP CAREFULLY WITH SIMPLEX OIL.

DAILY

ADD SAE #40 OIL AS REQUIRED TO MAINTAIN OIL LEVEL SHOWN WHEN MECHANISM IS AT REST. (ADD OIL ONLY AFTER MECHANISM HAS BEEN IDLE OVERNIGHT. DO NOT FILL TO RED LINE AFTER INITIAL FILLING WHEN INSTALLED.)

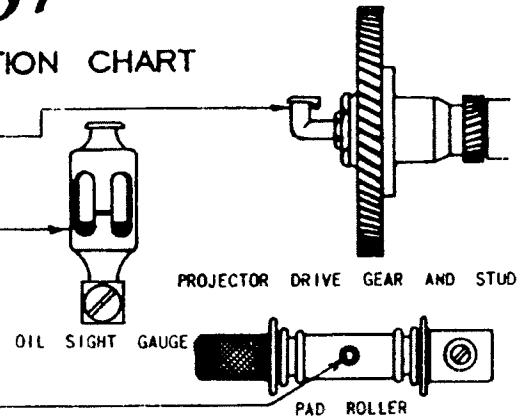

MONTHLY

APPLY 1 DROP OF SIMPLEX OIL TO THE OIL HOLE IN EACH PAD ROLLER. (ROTATE PAD ROLLER TO DISTRIBUTE OIL.) *

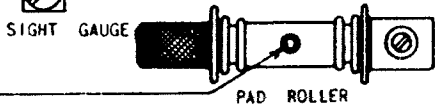

MONTHLY

APPLY 1 DROP OF SIMPLEX OIL TO THE SHAFT AT EACH END OF THE ROLLER. (ROTATE FLANGES TO DISTRIBUTE OIL.) *

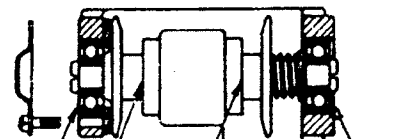

SEMI-ANNUALLY

APPLY 1 DROP OF SIMPLEX OIL TO EACH BALL BEARING. (ROTATE BEARINGS TO DISTRIBUTE OIL.) *

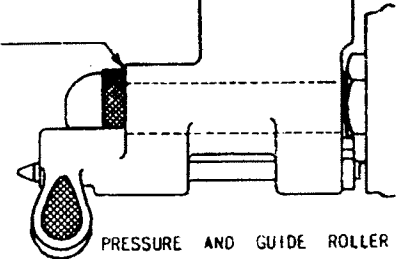

MONTHLY

APPLY 1 DROP OF SIMPLEX OIL TO THE SHAFT. (SLIDE ASSEMBLY IN TO APPLY OIL. OPERATE TO DISTRIBUTE OIL.) *

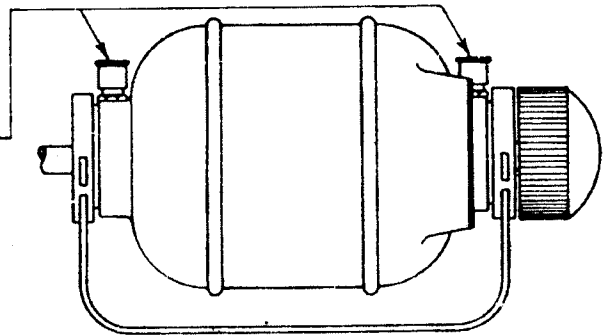

MONTHLY

GIVE EACH GREASE CUP ABOUT 1/2 TURN. DO NOT FORCE TOO MUCH GREASE INTO THE BEARINGS. REFILL WITH SIMPLEX REAR SHUTTER GREASE AS REQUIRED. MARFAK #2 (TEXACO) MAY BE USED AS A SUBSTITUTE.

SEMI-ANNUALLY

APPLY 1 DROP OF SIMPLEX OIL TO EACH BALL BEARING. (REMOVE DAMPING WHEEL AND TWO RETAINER RINGS. ROTATE BEARINGS TO DISTRIBUTE OIL.) *

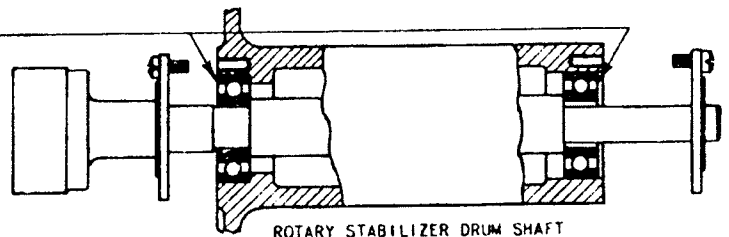

* APPLY SIMPLEX OIL WITH A TOOTHPICK OR PIPE CLEANER. DO NOT OVER-LUBRICATE. EXCESS OIL SHOULD BE CAREFULLY WIPED OFF WITH CHAMOIS OR LINTLESS CLOTH.

ISSUED BY
SOUND ENGINEERING DIVISION
INTERNATIONAL PROJECTOR CORPORATION
NEW YORK