

Film-Tech

The information contained in this Adobe Acrobat pdf file is provided at your own risk and good judgment.

These manuals are designed to facilitate the exchange of information related to cinema projection and film handling, with no warranties nor obligations from the authors, for qualified field service engineers.

If you are not a qualified technician, please make no adjustments to anything you may read about in these Adobe manual downloads

www.film-tech.com

Autoarc carbon arc lamp operation manual

BRITISH ARC LAMP CARBON MANUFACTURERS ASSOCIATION

CHADWELL WORKS GROVE ROAD CHADWELL HEATH ESSEX

Telephone: GOODMAYES 2421

INDEX

	PAGE
INTRODUCTION	1
SPECIFICATIONS	1
INSTALLATION	2
OPERATION	2
MAINTENANCE	
ADJUSTMENTS	4
THE ELECTRONIC CARBON FEED CONTROLLER	6
(i) ALIGNMENT	
(2) ADJUSTMENT	
(3) FAULT TRACING	
RECOMMENDED CARBON TRIMS FOR 35 mm. PROJECTION ii & iiA	
THE AUTOARC FOR 70 mm. PROJECTION	12

ILLUSTRATIONS

THE "AUTOARC" FIGURE A. GENERAL ASSEMBLY OF LAMP. B. LAMPHOUSE BASE PLATE.)p C. THE ARC MECHANISM. 3.1k D. THE ELECTRONIC CARBON FEED CONTROLLER.

33 E. CIRCUIT DIAGRAM.

.. .. . 7 R R



INTRODUCTION

The Autoarc has been designed to be applicable to any modern method of cinematograph film projection, and can be embodied in any of the automated systems which are available.

At the same time the full advantages of the modern carbon arc have been retained, viz. high light output, correct colour reproduction, adequate coverage of screen area and both flexibility and constancy of luminous output.

The secret of the lamp lies in a photocell controlled servomechanism which continuously regulates the rate at which both carbons are driven towards each other so that the intensity of the light is kept constant.

Once the lamp has been trimmed with carbons, control of the machine is maintained by operating two switches only.

The first is the usual arc supply control which, when switched on, will cause the arc to strike automatically and continue to run unattended for periods UP to 21 hours depending on the current loading and light required.

The second switch, the only one on the Autoarc itself, controls the opening and closing of the dowser.

Both switches may be operated at the lamp itself or may be connected to remote controls so that the machine can be operated from any part of the cinema.

The lamp may be powered by any normal DC carbon arc rectifier. The only additional supply needed is mains current for the internal inspection lamp.

A beamspreader lens is available on special order to permit the lamp to be used for 70 mm film projection. With this accessory, all that is required so far as the lamp is concerned, to change from 35 mm to 70 mm projection is to slide the lens in its carrier, into position.

SPECIFICATIONS

TYPE

Reflector type DC operated High Intensity Horizontal Arc.

CARBONS

Positive 8 mm. x 18" (455 mm. or 500 mm.) (copper coated).

Negative 6 to 8 mm x 12" (305 mm.) (copper coated) according to current employed.

The lamp may be adapted for 7 mm or 9 mm positives on special request.

OPTICAL

Ellipsoidal Mirror Diameter 14.0" (355 mm.).
 Minor Focus 5.0" (127 mm.).
 Major Focus 34.0" (864 mm.).

Optical Speed Nominally F/2.2 but faster projection lenses may be used to
 advantage (N.B.: Screen lumens in table 'I' are quoted when
 used with a lens of speed F/1.9).

Optical Height 9" (228 mm.).

SIZE OF LAMPHOUSE

Overall length 38 $\frac{3}{4}$ " (985 mm.).

Overall width 22.5" (572 mm.).

Overall height 25" (635 mm.).

The height at the front is 19" (483 mm.) to permit the use of large spool boxes.

INSTALLATION

1. REMOVING THE MECHANISM FROM THE LAMPHOUSE. If, on arrival, the lamphouse is packed with the mechanism inside, it is necessary to remove the mechanism before starting to install the unit. To do this disconnect the two sockets from the plugs (01) at the rear of the mechanism (see Figure A) and undo the two screws (02) which fix the mechanism to the lamphouse. Open the dowsers manually by pulling knob (40) and lock it with the manual catch. Then lift the mechanism onto the runners (03) and slide it out through the rear of the lamphouse.
2. MOUNTING THE LAMPHOUSE ON THE PROJECTOR PEDESTAL. (see Figure B) Bolt the lamphouse to the pedestal using the two front bolt holes (04) only. The optical height of the lamphouse is 9 inches (228 mm.) and should the optical height of the projector be more than this the difference must be made up by the use of packing pieces of thickness equal to the difference between the two optical heights. Such packing pieces must be used at both front and back of the lamphouse.
3. FIT THE MIRROR INTO ITS SUPPORTS.
4. REPLACING THE MECHANISM IN THE LAMPHOUSE. (see Figures A and B) Undo the two screws (02) and manually open the dowsers by pulling knob (40). Slide the mechanism into the lamphouse on the runners (03) so that the base plate comes flush against the stops (05). Slacken the front two bolts (04) and adjust the lamphouse position so that the optical axis of the lamp passes through the centre of the gate and the reflecting surface of the mirror is 34 inches \pm 1 inch (873 mm. \pm 25 mm.) from the gate. Tighten the two front bolts (04). Slide the mechanism from the lamphouse again and fix the two rear bolts (06) so that the lamphouse is firmly anchored to the projector pedestal. Replace the mechanism making sure that it is fully forward against the stops (05) and lock it in position with the two screws (02). The two sockets are now replaced into their respective plugs (01).
5. CONNECTING THE POWER LEADS TO THE TERMINAL BLOCK. The leads supplying the power to the arc are connected by wing nuts to the terminal block (07) at the rear lefthand side of the lamphouse. The rear terminal is positive. To operate, the fixed inspection lamp connect the main supply to the terminals (08).

OPERATION

The operation of the lamp is simplicity itself. Once the carbons have been fitted and adjusted to the correct arclamp and the dowsers closed, all that is needed is to switch on the power supply. The arc will strike automatically and the dowsers may be switched open as required.

FITTING THE POSITIVE CARBON (see drawing POS. HEAD MK. III) Raise the positive feed wheel arm (38). Push the point of the positive carbon into the rear of the positive contacts (40) until the point is halfway between the flame shield (8) and the negative V guide. Reposition the positive feed wheel release arm (38).

Check with the manual positive feed knob that the feed wheels (9) are engaged and will feed the positive carbon.

FITTING THE NEGATIVE CARBON (Figure C). Press in the quick release catch (45) and pull the negative head (52) to the rear of the lamphouse. Turn knob (46) anticlockwise to open the jaws, insert the negative carbon the front end of it passing through the mirror and resting on the support (53) and retighten the knob (46). Manual feed adjustment is made by the knob (54).

IMPORTANT. Once the arc is struck this manual adjustment of the negative carbon must not, be attempted whilst the magnetic clutch is engaged otherwise the fibre drive may be damaged.

STRIKING THE ARC (Figure A). Adjust the carbon positions to those determined by the Guide (see figure C). Remove the guide and ensure that the dowser is not held open by the manual catch. Turn on the electric supply to the lamp, when the arc will strike automatically. The dowser is opened by means of switch (41) when required. The lamp will run continuously without attention for the period of time shown in Table 'I'.

CARBON FEED INDICATOR LAMPS

Whilst the arc is running it will be observed that the red and blue indicator lamps on the rear panel of the lamphouse are intermittently illuminated. The purpose of this is explained under the section "Adjustment of the Electronic Carbon Feed Controller" and is an indication that the controller is operating.

MANUAL OPERATION OF THE DOWSER (Figure A). Normally the dowser will operate automatically by throwing switch (41). If required it can be operated manually by pulling the knob (40) outwards approx. 1/4" (32 mm.) and engaging the manual catch in the recess in the dowser spindle.

MAINTENANCE

1. **Mirror.** To maintain maximum light output the mirror should be cleaned regularly using a soft duster and applying a proprietary mirror cleanser of the whitening type. Abrasive polishes must not be used.
2. **Mechanism.** To facilitate maintenance to the mechanism it can be removed from the lamphouse as described, under 'Installation'. All bearings are of the self-lubricating "Reservoir" type and need no further attention. A light graphite oil ("Foliac" Arc Lamp Lubricant is recommended) may be applied sparingly to the gears but care must be taken to avoid a build up of graphite deposits in positions which could cause a short circuit between insulated parts.
No maintenance is required to the feed motor other than periodical inspection and cleaning of the commutator and replacement of brushes.
3. **Dowser.** No maintenance is required under normal conditions other than periodic lubrication of the moving joints with graphite oil. The whole unit may, however, be removed from the lamphouse as follows (see Figure A):

Two screws release the shield covering the base of the dowser unit, revealing the four screws (48) fixing the unit to the lamphouse base. Pull out the two pin plug from the back of the control panel. Remove the linkage pin (50) connecting the dowser to the mirror shield. Pull out the connecting pin (51) on the dowser manual shaft and unscrew this shaft. Finally, remove the four screws (48) and the two screws holding the dowser aperture plate to the front of the lamphouse. The dowser can now be lifted out of the lamphouse.

ADJUSTMENTS

Before the lamp leaves the factory it has been tested and all parts correctly aligned. Generally, therefore, no adjustments will be necessary after installation. Should, however, any further adjustment prove necessary, proceed as follows :

1. **ALIGNMENT OF THE POSITIVE CARBON HOLDER (see drawing Positive Head MK. III).** Remove the mechanism from the lamphouse. Lift off the flame shield (8) and slag tray (2). Push a positive carbon into the positive contacts (40). Loosen the two screws holding the fixed positive contact arm (75) and also the two screws holding the movable contact arm to its pivot block (77).
Adjust the position of the fixed contact arm (75) so that the positive carbon lies in the horizontal plane of the optical axis. Tighten the two holding screws.

Adjust the movable contact arm (76) so that the positive contact fits to the positive carbon. Tighten the two holding screws in the pivot block (77).

Slacken off the holding screw on the positive V guide (78) and adjust until the carbon is parallel to the baseplate. Tighten this screw. Remove the positive carbon. Replace the slag tray and flame shield. Replace the mechanism in the lamphouse and check that the positive carbon when replaced, passes centrally through the hole in the lamphouse dowsers.

The positive carbon now forms the optical axis of the lamp and the negative carbon and mirror are now aligned to it.

2. ALIGNMENT OF NEGATIVE CARBON HOLDER

- (a) Lateral alignment. Remove the mechanism from the lamphouse and fit positive and negative carbons in the lamp as described under 'Operation'. Loosen bolt (13) and adjust the negative carbon laterally by twisting the positive feed knob (14). Retighten bolt (13).
- (b) Vertical alignment. Slacken nut (15) and turn adjusting screw (16) until the negative carbon is correctly positioned to give a vertical positive crater. Strike the arc as described under 'Operation', and allow to burn, making any final adjustments necessary.
- (c) The negative carbon holder has two side plates that run in machined grooves on each side of the lead screw casting. These side plates have slightly oversize holes and adjustment can be made in conjunction with the negative V-guide (53) which also has elongated holes, so that the negative carbon will seat correctly in the V-guide and remains parallel to the optical axis throughout its entire travel.
When adjusting, first check with a new 12" (305 mm.) carbon to see that it is parallel to the axis and then recheck with a stub end of carbon with the carbon holder close to the V-guide to make sure that it remains parallel over its entire length of travel.

3. ALIGNMENT OF MIRROR SUPPORTS.

Remove mechanism from lamphouse and fit a positive carbon into the jaws. Feed the carbon forward so that it passes through the hole in the mirror. Loosen the Allen screws (17) on the two lower mirror supports and adjust the position of these supports until the carbon passes through the centre of the hole in the mirror. Retighten the screws and release the lock nuts (18) on all four mirror supports. Adjust by screwing the supports in or out so that a straight edge lying across the circumference of the mirror is at right angles to the positive carbon both horizontally and vertically. Withdraw the carbon until it protrudes only about $7/8$ " (22 mm.) from the flame shield. Then adjust the minor focus of the mirror by screwing all the mirror supports an equal number of turns until the reflecting surface of the mirror is 5.0 inches (127 mm.) from the tip of the positive carbon. Now retighten the lock nuts (18). Further fine adjustment of the mirror can be carried out when the lamp is running by using the mirror control knobs (19) for vertical, and (20) for horizontal tilt.

4. ALIGNMENT OF ELECTRONIC CARBON FEED CONTROLLER.

The case containing the electronic carbon feed controller is mounted on the side of the lamphouse opposite the door and is exposed simply by unscrewing a nut and removing the cover. This unit has been lined up before leaving the factory and should not require further attention.

Adjustment to this unit is fully described in the section "Electronic Carbon Feed Controller".

5. ADJUSTMENT OF DOWSER LINKAGE (Figure A).

Should the dowsers fail to close properly or close too fiercely then adjustment to the tension of spring (35) by means of screw knob (36) will correct this.

The mirror shield should be central when the dowsers are closed. If this is not the case adjust the length of the linkage rod (37) by means of the screw threads at each end of the rod, and finally secure with the locking nuts (38).

If the dowsers fail to operate electrically, check the 5 amp fuse on the control panel. If it fails to open fully, check the action of the micro switch situated beneath the dowsers chassis.

It will be necessary to remove as described under maintenance, the dowsers unit for this purpose.

The dowser micro switch is operated by an adjustable screw. This screw should be set so that the micro switch operates just before the dowser barn doors are fully open. The action of this switch is to bring into the dowser solenoid circuit a 30 ohm resistor (see circuit diagram).

If this micro switch operates too early, then the current to the solenoid is reduced before the barn doors are fully open. This reduced current will prevent the solenoid from completing this action.

THE ELECTRONIC CARBON FEED CONTROLLER (Figure D)

The principle on which this works is straightforward. The positive carbon is being continuously driven forward by a variable speed motor which compensates for the rate at which the rod burns away. The negative carbon is only driven forward in steps when it has burnt back. The control unit is so arranged that as the carbons get further from their optimum positions the light falling on photocells alters. This energises servomechanisms which either accelerate the rate at which the positive carbon is fed forward or engage the clutch of a drive mechanism which feeds forward the negative carbon. As soon as the light intensity returns to its optimum, the servomechanisms stop. The sensitivity of the photocells is so high that the carbons never deviate by more than 0.25 mm. from their correct positions.

THE POSITIVE CARBON.

The feed motor resistance is set to *Minimum Speed*. Movement of the positive carbon *BACKWARD* reduces the light on the Photoconductive Cell (25) and *FORWARD* increases the light on the cell. The cell is in one leg of the circuit of the *POLARISED RELAY* (26) and the balance of this circuit for any given level of light on the cell is achieved by adjusting the *POTENTIOMETER* (27).

The circuit must be balanced when the positive carbon is in the correct minor focus to the mirror. As the carbon feed motor is set to minimum speed, the positive carbon will fall back from its correct position and the light on the cell will be reduced.

This reduction in light on the cell will unbalance the Polarised Relay circuit and contacts on the relay will short out part of the feed motor resistance switching the motor from slow to fast feed.

As a result the positive carbon will feed forward faster and the level of light on the cell will continue to increase until the positive carbon has returned to its original position.

The balance of the circuit is then restored and this sequence of events is repeated.

It is essential that the positive carbon image is positioned so that the slit is in front of the positive carbon.

If the image of the positive crater is positioned so that the crater edge is on the slit, then movement of the positive carbon both *FORWARD AND BACKWARD* will cause the light passing through the slit and on to the *POSITIVE CELL* (25) to fall. Then a slight lip developing on the carbon would cause the positive carbon to overfeed.

NEGATIVE.

Movement of the Negative carbon *BACKWARD* increases the light on the *Photoconductive Cell* (29) and *FORWARD* decreases the light on the cell.

The cell is in one leg of the circuit of the *POLARISED RELAY* (30) and the balance of this circuit for any given level of light on the cell is achieved by adjusting *POTENTIOMETER* (31).

The circuit must be balanced when the negative carbon is at the correct distance from the positive crater. As the negative carbon feed is via a magnetic clutch the negative carbon is not fed forward until this clutch is energised, so that as the negative carbon burns away the light on the cell increases.

This increase in light on the cell will unbalance the Polarised Relay circuit and contacts on the relay will complete the circuit to the magnetic clutch.

The magnetic clutch, now being energised, will transmit the drive to the negative carbon.

The negative carbon will feed forward and the level of light on the cell will continue to decrease until the negative carbon has returned to its original position.

The balance of the circuit is then restored and this sequence of events is repeated.

(1) ALIGNMENT OF THE ELECTRONIC CARBON FEED CONTROLLER

POSITIVE OPTICAL UNIT

This unit is marked with a *RED SPOT*.

With the carbons in their correct operating position see that an image of the carbons is across the *POSITIVE SLIT* (21) with the slit slightly off centre, towards the positive carbon.
(The *POSITIVE SLIT* (21) is narrower than the *NEGATIVE SLIT* (22).)
There are three adjustments that may be made to the *POSITIVE OPTICAL UNIT* (23) to achieve this.

(a) *Horizontal Alignment*

The bottom mounting hole of the optical unit is elongated to permit a horizontal alignment.

(b) *Vertical Alignment*

The optical head securing screw will permit tilt in the vertical direction.

(c) *Height Adjustment*

The elongated hole that the securing screw passes through allows optical height adjustment.

With these three adjustments it is possible to align correctly the optical unit.

When this is completed, the screws must be tightened and coated with shellac. No further adjustment of this unit will be required.

NEGATIVE OPTICAL UNIT

The *NEGATIVE OPTICAL UNIT* (24) is marked with a *BLUE SPOT*.

With the carbons in their correct operating position see that an image of the negative carbon is positioned so that the bright tip of the negative carbon is slightly in front of the *NEGATIVE SLIT* (22).

The adjustments to the *NEGATIVE OPTICAL UNIT* (24) for

(a) Horizontal Alignment

(b) Vertical Alignment

(c) Height Adjustment are the same as for the *POSITIVE UNIT*.

(2) ADJUSTMENT OF THE ELECTRONIC CARBON FEED CONTROLLER

Positive and Negative carbon adjustments are completely independent of each other. The positive carbon must be adjusted first.

Adjustments to the Positive and Negative Potentiometer (27 and 31) controls must be carried out with the Automatic controller cover on so that no external light can fall onto the cells.

POSITIVE.

When the positive carbon is switched to fast feed, a *RED* indicator light at the rear of the lamphouse is illuminated and the positive carbon will feed forward until this light goes out.

If the position of maximum light on the screen has not been reached before the *RED* indicator lamp goes out, then turn *POTENTIOMETER* (27) clockwise by inserting a screwdriver through the hole in the case. This lamp will then come on and the positive carbon will feed forward. If the positive carbon feeds too far forward, i.e. beyond the point of maximum light on the screen, then adjust the *POTENTIOMETER* (27) anticlockwise.

NEGATIVE.

When the negative magnetic clutch is energised a *BLUE* indicator lamp at the rear of the lamphouse is switched on and the negative carbon will feed forward until the *BLUE* lamp goes out.

Potentiometer (31) must be adjusted clockwise if the arc gap is too long and anticlockwise if the arc gap is too short. Adjustment to these two potentiometers are the only adjustments normally required.

(3) FAULT TRACING OF THE ELECTRONIC CARBON FEED CONTROLLER

In the event of imperfect performance the operator should carry out the following simple tests :

i. Remove cover from the electronic carbon feed control.

2. Remove the covers from the relays (sliding fit).

3. With the arc burning, gently move the relay armature from side to side with the tip of the finger.

The positive relay, marked with a red spot, should switch the feed motor from fast to slow speed and should also switch the red indicator light on and off.

The negative relay marked with a blue spot should energise and de-energise the Magnetic Clutch (this can be heard with a distinct click) and the blue indicator light should be switched on and off.

If the motor switches from fast to slow speed and the Magnetic Clutch can be heard clicking but no indicator lights operate then there is no supply to the electronic controller.

Remedy: check 1 amp. fuse on the control panel.

If one indicator lamp only operates, the 1 amp. fuse must be intact. Remedy: check other lamp. If necessary replace.

If both relays function all right and the indicator lamps work replace relay covers. Relay covers must be kept on at all times except for test purposes.

These checks show (a) that the relay contacts are working, (b) that the main 1 amp. fuse feeding the electronic carbon feed control is all right and (c) that there is no current break in the wiring and 8-way plug to the lamp mechanism.

4. With the arc burning, place a finger over the POSITIVE cell slit.

The feed motor should switch to fast speed and the red indicator lamp should come on.

If this does not occur or is permanently on fast feed, then the relay circuit is not "balanced".

This will be due to

- (a) Faulty Photoconductive Cell.
- (b) Potentiometer incorrectly set.
- (c) Change in the ohmic value of the fixed resistors.
- (d) Faulty wiring.
- (e) Incorrect level of light on the cell.

To assist in obtaining the correct balance of the polarised relay a wire " LINK " is provided between the centre terminal of Potentiometer and the relay. This " LINK " which is colour coded YELLOW, should be unsoldered and a milliammeter inserted in the broken circuit.

If no reading is obtained on the meter., then a fault in the internal wiring of the controller must be the cause. Check wiring.

If, with the arc burning under its correct conditions, a reading is obtained, adjust the appropriate Potentiometer so that the meter reads Zero (approx.).

If this is not possible carry out the following checks

1. Check the Photoconductive Cell. With no light on the cell (i.e. cell completely covered) the resistance between the two working pins is approx. 1 Megohm but with light on the cell this resistance value will fall (exposed to normal daylight, resistance will be approx. 50 ohms).

DO NOT FORGET that each electronic carbon feed controller has two identical cells and these can be cross checked with each other.

2. Check the resistance value of the fixed resistors. Tolerance $\pm 10\%$.

3. With the *Positive* side of the milliammeter connected to the positive relay end of the " LINK " and the *Negative* side of the meter to the centre tag of the potentiometer, a *REDUCTION* in light on the cell (i.e. placing a finger over the cell slit) will *INCREASE* the meter reading.

If an increased reading is required to balance the circuit then the light level on the cell must be reduced. A repositioning of the carbon image either higher or lower up the cell slit, will generally achieve this.

If a decreased reading is required to balance the circuit then the light level on the cell must be increased. This can generally be achieved by cleaning the lens or mirror of the optical unit.

Once the balance has been approximately reached, then final setting can be made by adjusting the potentiometer.

If the above has been carried out, the arc should now be operating correctly in the following sequence :

Arc burning correctly positive in correct minor focus.

MA Meter reading zero.

Positive feed motor slow speed - Positive falling back - Meter reading increased to 0.3 to 0.4 ma.

Polarised relay operates - feed motor fast speed - Meter reading decreasing to zero - Positive carbon back at its correct position.

The maximum movement of positive crater should not exceed 0.25 mm.

If the relay closes at less than 0.3 ma., the contact gap is too small.

If the relay closes at more than 0.4 ma., the contact gap is too large.

In either case an adjustment should be made to the polarised relay. The M.A. meter should be removed from the circuit and the " LINK " resoldered.

The negative relay circuit is identical to that of the positive relay circuit and can be checked in the same manner.

When the potentiometer has been correctly adjusted (with the case cover on) no alteration to these controls is necessary, *UNLESS* the carbon grade or the operating conditions are altered.

Current variations, due to main voltage fluctuations, is looked after by the electronic carbon feed controller, within the current limits of the carbon grade.

TABLE '1'
Recommended Carbon Trims for 35mm Projection

The screen lumens quoted below are obtained, using an F/1.9 lens and a standard aperture (0.835" x 0.600") without a flicker shutter.

Screen lumens required	Amps.	A/V	Positive Carbon	Negative Carbon	Burning time with (455 mm.) carbon
10,750	40	35	Link CA 7	Link NC 6	135 mins.
13,500	45	38	Link CA 7	Link NC 6	85 mins.
12,000	50	37	Link CA 8	Link NC 7	135 mins.
4,250	55	39	Link CA 8	Link NC 7	100 mins.
15,000	60	41	Link CC 8	Link NC 7	90 mins.
16,750	65	43	Link CC 8	Link NC 7	70 mins.
18,500	70	45	Link CC 8	Link NC 7	60 mins.
18,000	70	39	Link CA 9	Link NC 7	75 mins.

Recommended Carbon Trims for 70 mm. Projection using the Beam Spreader Lens.

The screen lumens quoted below are obtained, using an F/1.8 lens and a standard aperture (1.911" x 0.8661") without a flicker shutter.

Screen lumens required	Amps.	A/V	Positive Carbon	Negative Carbon	Burning time with (455 mm.) carbon
17,000	65	43	Link CC 8	Link NC 7	70 mins.
19,000	70	45	Link CC 8	Link NC 7	60 mins.
18,500	70	39	Link CA 9	Link NC 7	75 mins.

THE AUTOARC FOR 70 MM FILM PROJECTION.

The Autoarc is available with a special nose cone carrying a "Beam spreader" lens for use with 70 mm. film, giving screen lumens as quoted in Table 1. With this adaption all that is required, so far as the lamp is concerned, to change from

35 mm. to 70 mm. film projection is to slide the lens carrier (56) see figure B into the nose cone until it clicks into position. No change of mirror, focal positions or carbon trim is required.

The beam spreader is a plano-concave cylindrical lens mounted with the wide chamfer at the sides and normally, with the plane face towards the mirror (see below for alternative mounting). It is appropriately positioned in the reflected cone of light from the mirror so as to spread the lightspot over the width of the 70 mm. film aperture with a minimum of light spill. The 15 mm. hole in the centre of the lens has been introduced to avoid restriction of the length of the positive carbon used. The four nylon blocks (57) are adjustable so that this central hole may be aligned accurately with the optical axis of the lamp. Insertion of a positive carbon into its holder will provide a guide for this alignment.

Autoarc lamps may be purchased with the beamspreader adaption fitted or, alternatively, the adaption may be purchased as an accessory to be fitted to existing Autoarcs presently used for 35 mm. projection only.

To fit, remove the standard cone which is held by the three screws (55) to the front of the lampholder. Using the same screws fit the beamspreader cone into position, insert the lens carrier and align the lens with the optical axis as above.

Should the lens so mounted give too flat a light distribution over the screen, the four nylon blocks on the carrier may be removed and remounted back to front. The lens when reinserted, now with the plane face towards the screen, will be positioned a little nearer the film aperture, thus reducing the spread of light and increasing the total screen lumens.

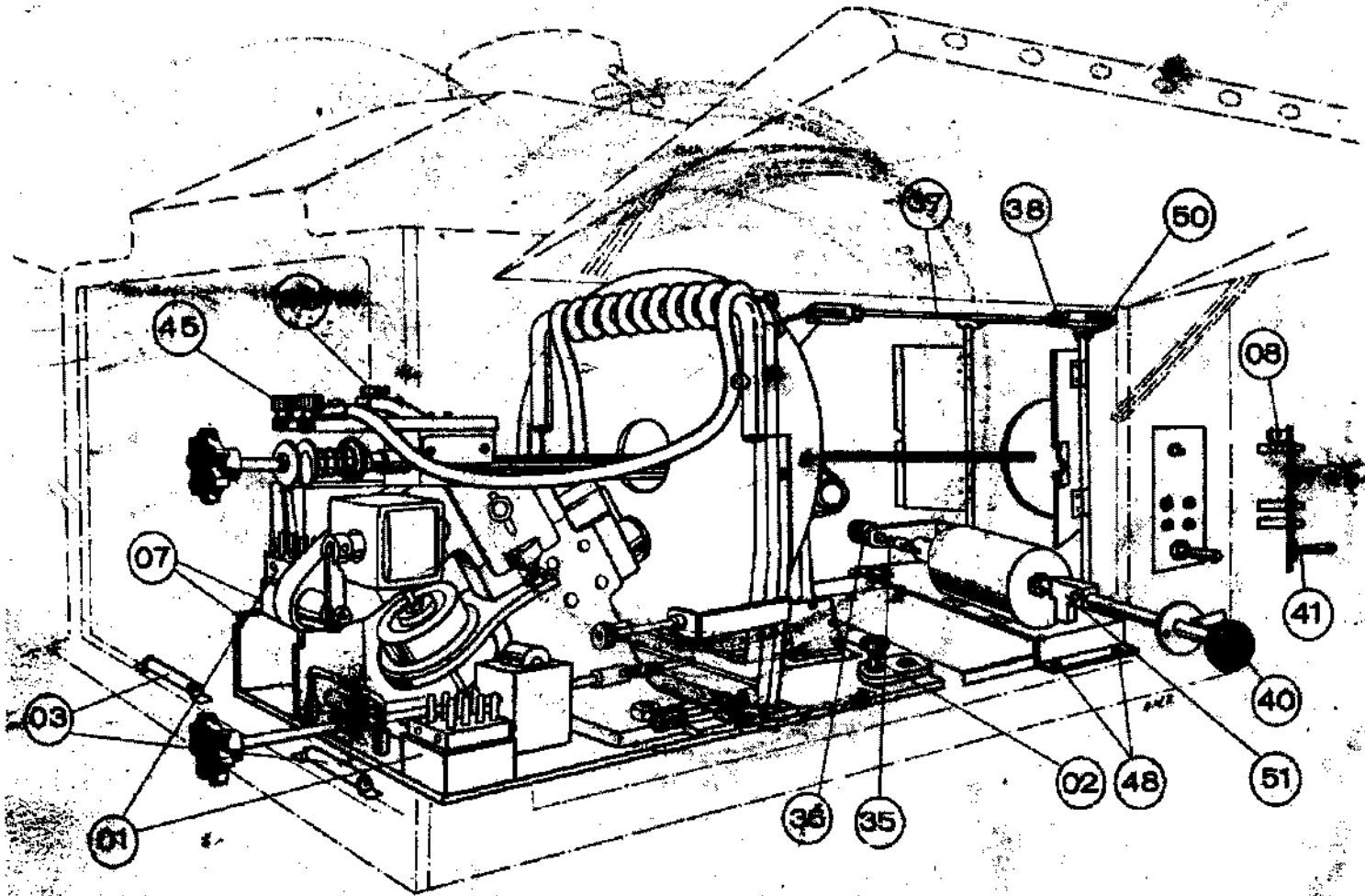

FIGURE A

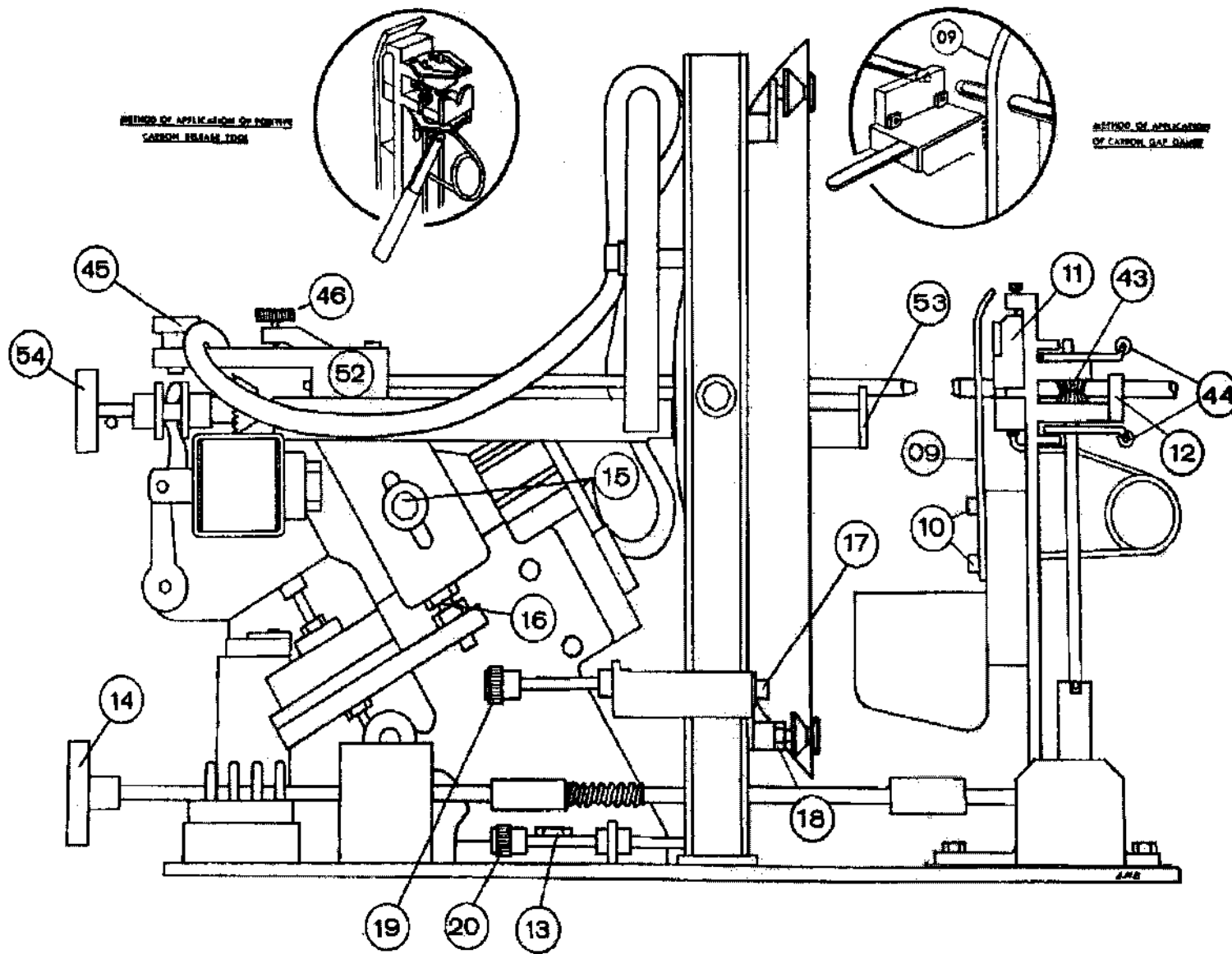

FIGURE C

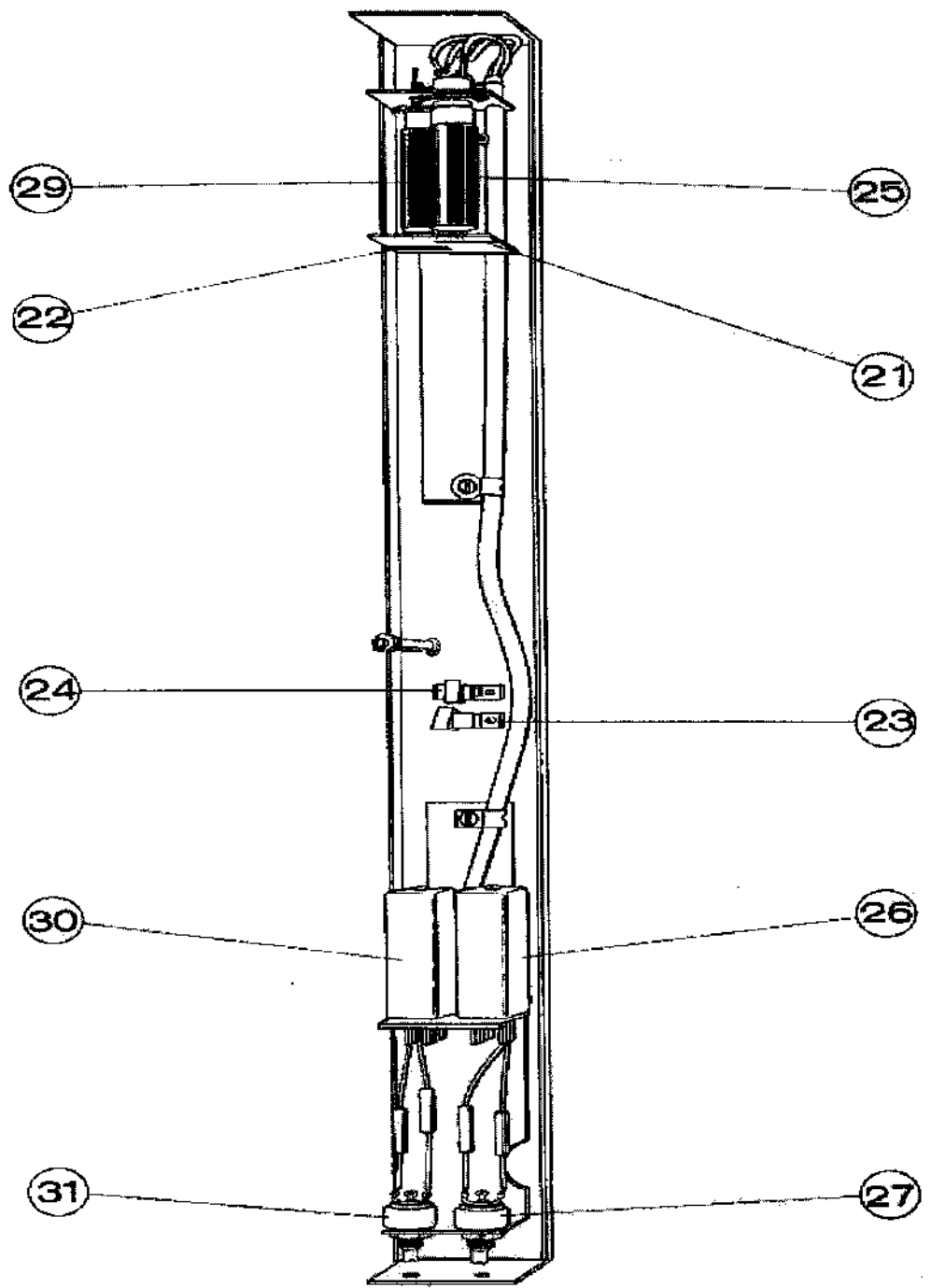

FIGURE D

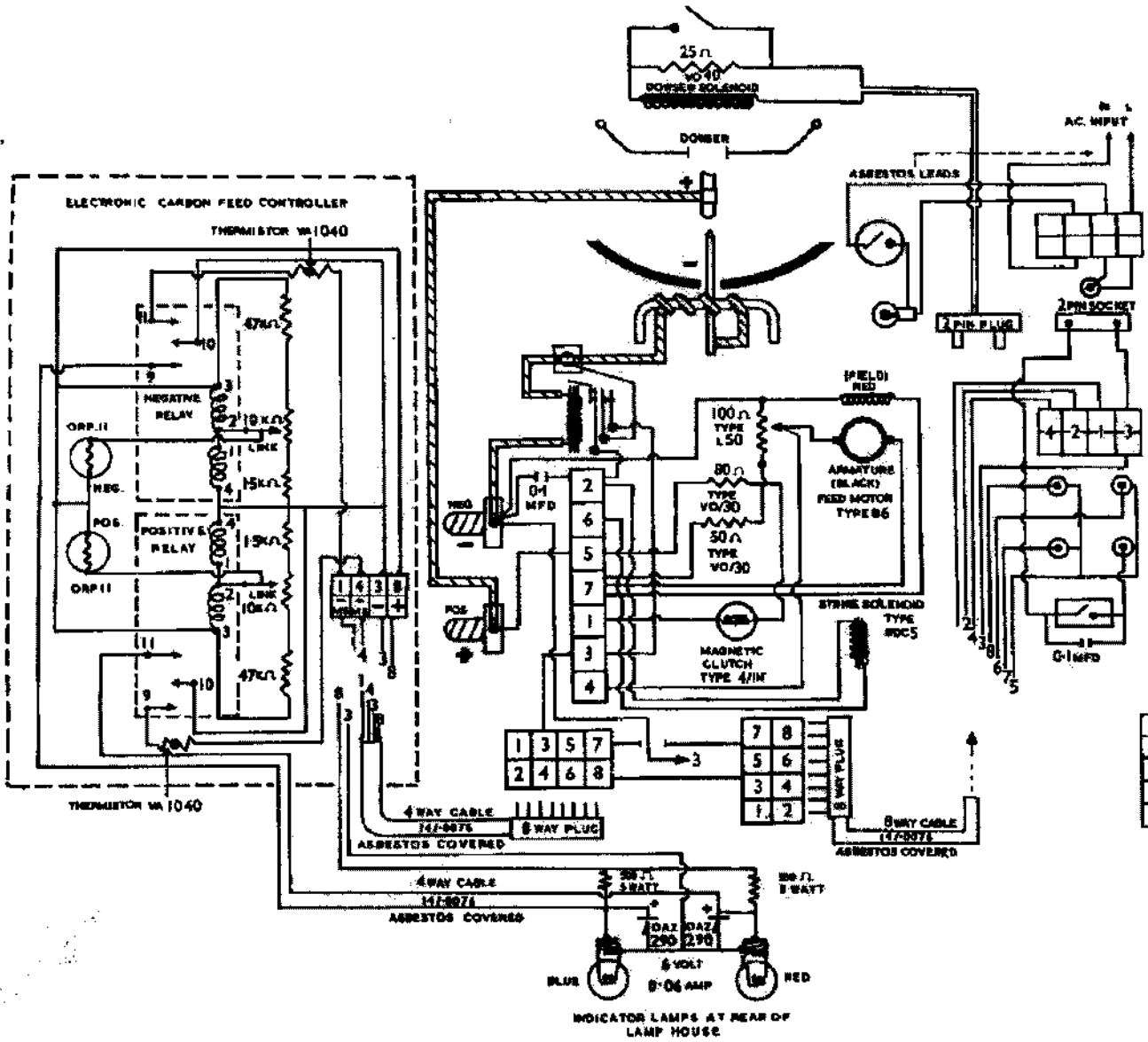

FIGURE E