

Film-Tech

The information contained in this Adobe Acrobat pdf file is provided at your own risk and good judgment.

These manuals are designed to facilitate the exchange of information related to cinema projection and film handling, with no warranties nor obligations from the authors, for qualified field service engineers.

If you are not a qualified technician, please make no adjustments to anything you may read about in these Adobe manual downloads.

www.film-tech.com

OPERATING INSTRUCTIONS
FOR
L-2000 THEATER SYSTEM

RENTEC CORPORATION
UPLAND, CALIFORNIA

TABLE OF CONTENTS

<u>SECTION</u>	<u>PAGE</u>
<u>LIST OF DATA SHEETS</u>	iii
<u>LIST OF DRAWINGS</u>	iii
<u>LIST OF FIGURES</u>	iii
1 <u>INTRODUCTION</u>	
1.1 General Description	1-1
1.2 Optic System	1-1
1.3 Power Supply	1-1
1.4 Circuit Breaker Controls	1-4
1.5 Control Panel	1-6
1.6 Reflector and Focus Mechanism	1-8
1.7 Folding Mirror	1-8
1.8 Bulb Alignment Controls	1-8
2 <u>INSTALLATION</u>	
2.1 Receiving - Handling	2-1
2.2 Mechanical Installation	2-1
2.3 Mechanical Alignment	2-1
2.4 Electrical Installation	2-1
2.5 System Wiring Pre-Check	2-6
2.6 Xenon Bulb Installation	2-7
3 <u>OPERATION</u>	
3.1 Start-Up Procedure, New System	3-1
3.2 Optical Alignment, New System	3-2
3.3 Optical Alignment (After Bulb Replacement)	3-4
3.4 Voltage Tap Adjustments	3-5
3.5 Start-Up Procedure	3-5
3.6 Shut-Down Procedure	3-6

TABLE OF CONTENTS
(Continued)

<u>SECTION</u>	<u>PAGE</u>
4	<u>MAINTENANCE</u>
4.1	Cleaning of Optics4-1
4.2	Blowers4-1
4.3	General Condition4-1
5	<u>TROUBLESHOOTING</u>
5-1
6	<u>DATA SHEETS AND DRAWINGS</u>

LIST OF DATA SHEETS

4C442 Blower Maintenance Sheet
4C444 Blower Maintenance Sheet

LIST OF DRAWINGS

<u>DRAWING NO.</u>	<u>TITLE</u>
B-1000370	Schematic, Power Supply
B-1000371	Schematic, Igniter
D-1001286	Schematic, Lamphouse

LIST OF FIGURES

<u>FIGURE NO.</u>		<u>PAGE</u>
1-1	L-2000 Theater System	1-2
1-2	Power Supply	1-3
1-3	Circuit Breaker Locations	1-5
1-4	System Controls Location	1-6
2-1	Projector Position	2-2
2-2	Pivot Mechanism Adjustment	2-3
2-3	Terminal Board Locations	2-4
2-4	Xenon Lamp Installation	2-8
3-1	Projector Alignment	3-3
3-2	Voltage Tap Locations	3-5

SECTION 1 - INTRODUCTION

1.1 GENERAL DESCRIPTION

The L-2000 Theater System (see Figure 1-1) is a complete lamphouse, sound and power supply unit. Included in the system is the xenon light source, power supplies, circuit breaker and control systems. The console is designed to provide super-high light intensity for optimum screen presentations.

1.2 OPTICS SYSTEM

Included in the optics system of the console is a xenon bulb vertically mounted in a nickel elliptical reflector which collects the light emitted from the xenon bulb and reflects it up to a 45° folding mirror - this mirror folds the light and projects it horizontally out of the lamphouse to the aperture of the projector.

The folding mirror is, technically, a dichoric cold mirror and is designed to reflect the white light and pass the film-damaging infrared light thru the glass (pyrex) into the air-cooled heat sink.

Using this system, the console is capable of producing maximum useful light without passing the infrared heat.

The built-in douser is operated by a handle on the right side of the console, beside the snout. The douser is provided to close off light to the projector while the xenon bulb is on.

1.3 POWER SUPPLY - DESCRIPTION

The power supply is located in the bottom of the console. The power supply (see Figure 1-2) contains a power contactor, a three-phase main power transformer, a three-phase rectifier, a capacitive filter and an open-circuit voltage boost kit.

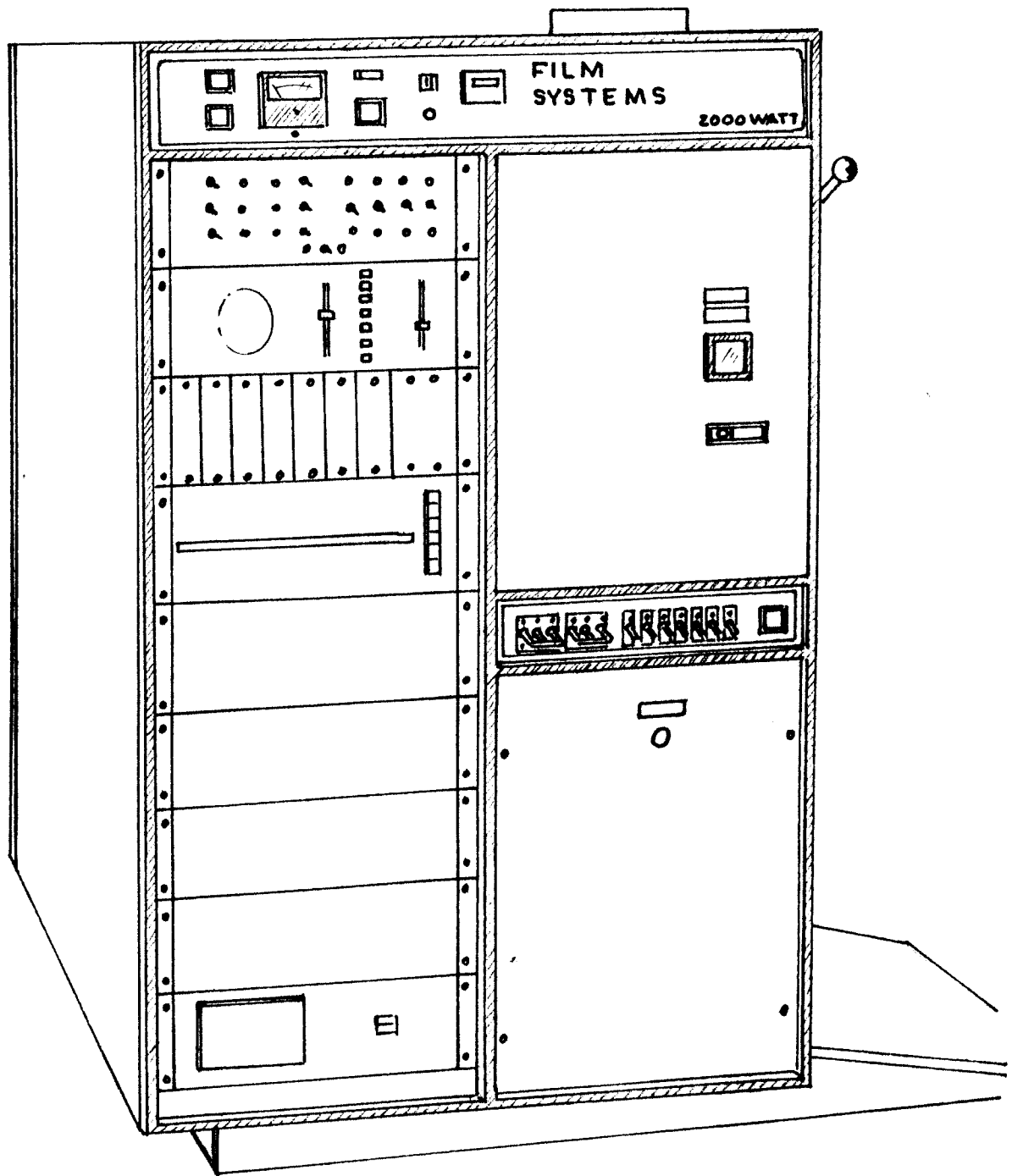

Figure 1-1. L-2000 Theater System

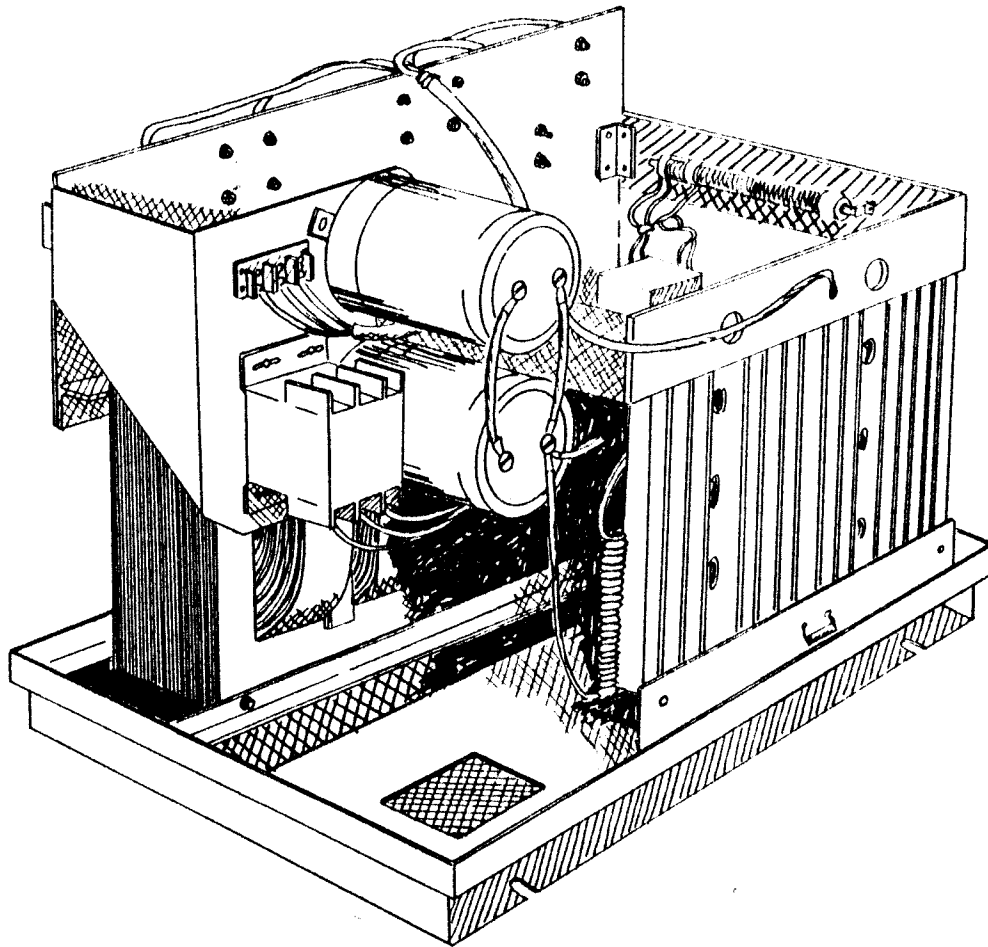

Figure 1-2. Power Supply

The power supply is designed for high reliability and is rated above the 2000 watt average use. This has been done to provide long trouble free power supply life.

Current adjustments are made by changing taps. There are four coarse (W,X,Y,Z) and four fine adjust taps (1,2,3,4) on each power supply. The current range is from 50 to over 90 amperes.

CAUTION

WHEN SETTING TAPS DO NOT EXCEED SPECIFIED CURRENT REQUIREMENTS OF XENON LAMP BEING USED. BULB DAMAGE OR SHORTENED LAMP LIFE WILL OCCUR.

1.4 CIRCUIT BREAKER CONTROLS (Figure 1-3)

1.4.1 POWER SUPPLY

The "POWER SUPPLY" circuit breaker is a 25 amp, 3-phase magnetic breaker which controls the 208/230 VAC lines to the power supply.

1.4.2 PROJECTOR

The "PROJECTOR" circuit breaker is a 10 amp, 3-phase magnetic breaker which controls the 208/230 VAC to the projector motor.

1.4.3 LAMPHOUSE

The "LAMPHOUSE" circuit breaker (10 amp) controls the 115 VAC to the blowers and control panel.

1.4.4 ACCESSORY (ACC)

The "ACC" circuit breaker (10 amp, 110 VAC) is installed to protect the duplex outlets and the external exhaust blower system.

1.4.5 SOUND

This 30 amp circuit breaker is installed to protect the sound amplifier system when supplied with the console.

1.4.6 AUTOMATION

The "AUTOMATION" circuit breaker, rated at 10 amps, 115 VAC, is installed to protect the automation and light-dimmer control systems.

1.4.7 MASKING

This circuit breaker (10 amps) controls the 115 VAC to the masking motors in the theater.

1.4.8 TRANSPORT

The "TRANSPORT" circuit breaker is rated at 10 amps and controls the 115 VAC to the film transport system.

1.4.9 CURTAIN

The "CURTAIN" circuit breaker (20 amps, 115 VAC) provides circuit protection for the curtain drive motor.

1.4.10 MAIN POWER SWITCH

This switch controls the coil of the main power contactor located inside of the lamphouse (non-operator's side). It is used to provide power to every item serviced by the circuit breaker panel. The coil for this contactor is protected by a "push-in" circuit breaker located next to the door in the back of the lamphouse.

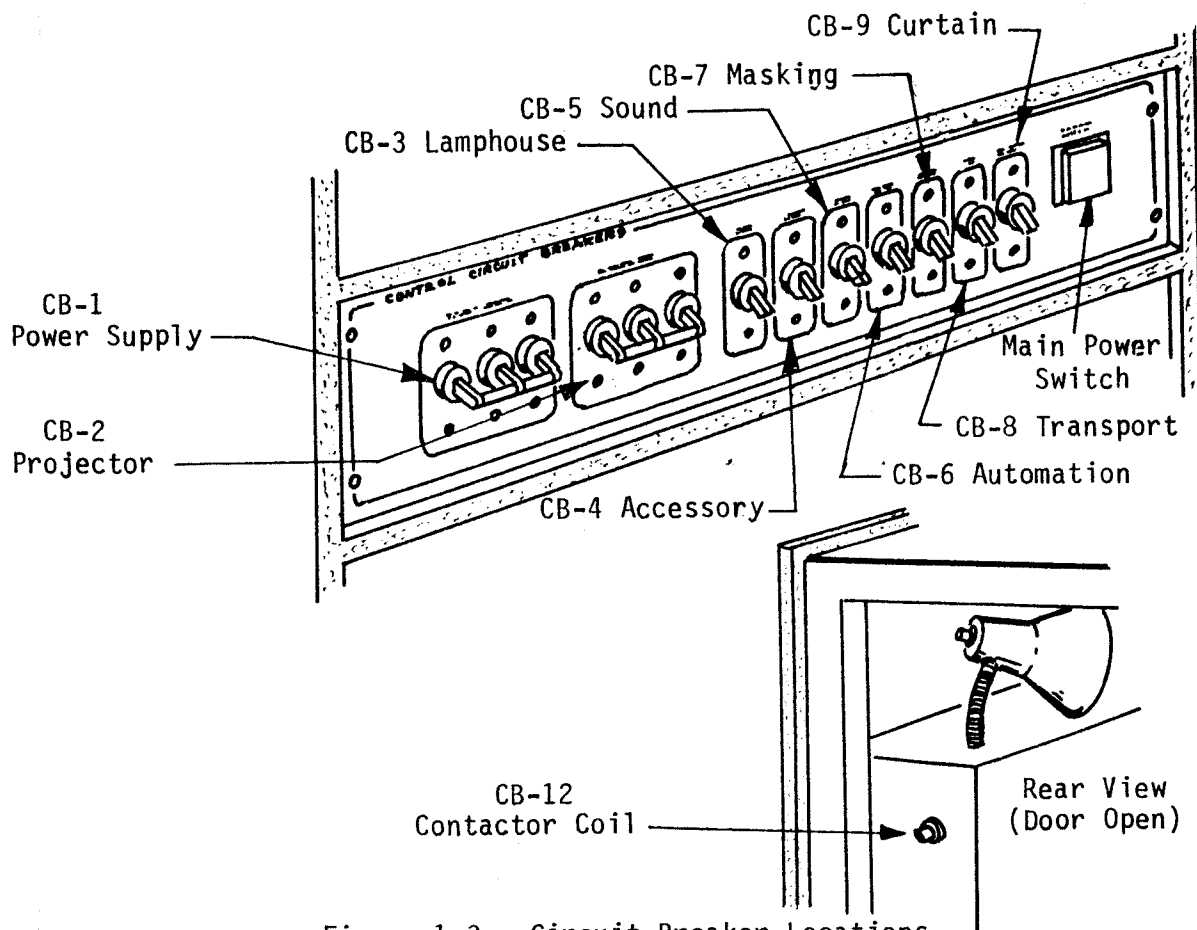

Figure 1-3. Circuit Breaker Locations

1.5 CONTROL PANEL (Figure 1-4)

1.5.1 "POWER ON" SWITCH

The "POWER ON" switch controls the blower functions and provides power thru the "AIR FLOW" switch to the "LAMP ON" switch. When the "POWER ON" switch is activated, the power light will be on.

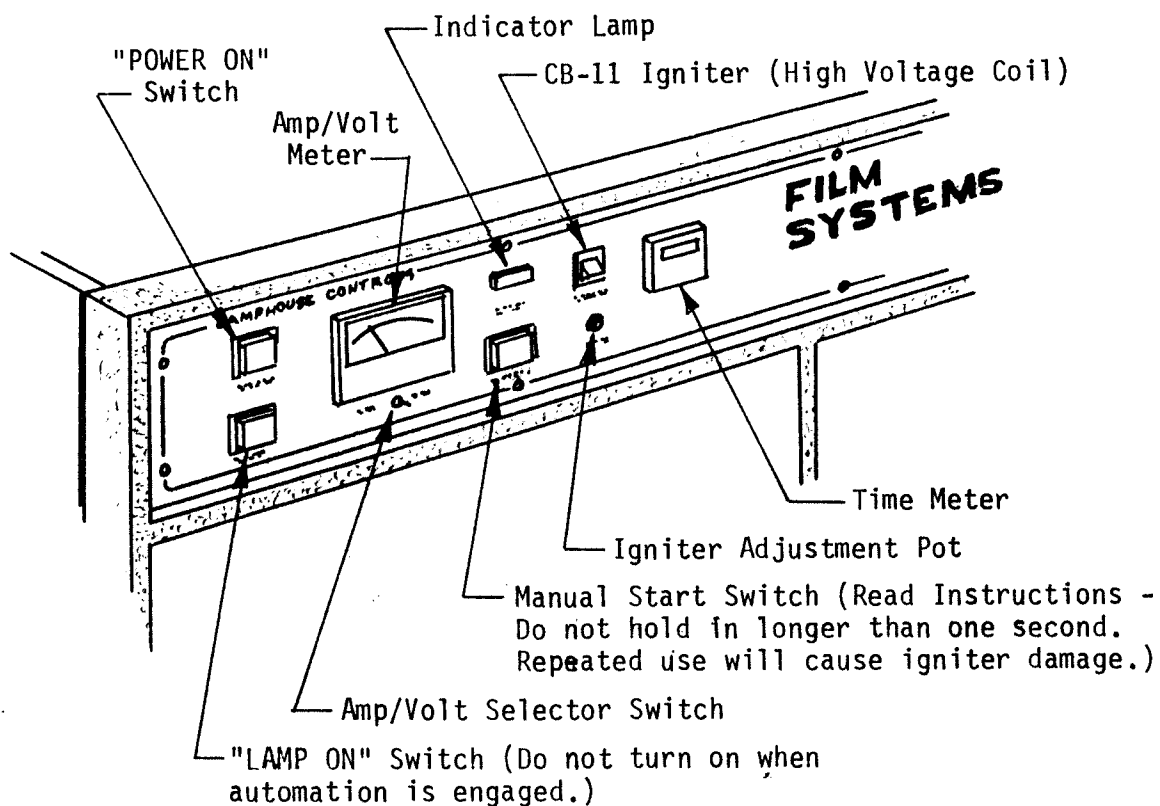

Figure 1-4. System Controls Location

1.5.2 "LAMP ON" SWITCH

The "LAMP ON" switch provides power to the bulb igniter and related circuitry. The "POWER ON" switch must be activated to operate this switch. This switch will not operate unless the air-flow interlock is closed (blowers working). When the "LAMP ON" switch is on, the "LAMP ON" indicator lamp will light.

1.5.3 "INTERLOCK OPEN" LAMP

This light will be "on" if the interlock switches fail to engage.

1.5.4 "MANUAL START" SWITCH

The "MANUAL START" switch is a momentary push-button switch. Use this switch only as an emergency bulb-starting device if the automatic igniter circuit fails to ignite the xenon bulb.

1.5.5 IGNITER CIRCUIT BREAKER

This 1 amp circuit breaker protects the igniter circuit from overload.

1.5.6 IGNITER VOLTAGE ADJUST

This adjustment is to vary the igniter current and should be adjusted after installation as follows:

- A. Turn control counterclockwise all the way.
- B. Turn on system.
- C. Adjust control clockwise until igniter ignites lamp. No further adjustment is required if this setting consistently ignites lamp. Readjust control, if required, to obtain consistent ignition of lamp on every start. Voltmeter will possibly go past full scale during ignition.

1.5.7 RUNNING TIME METER

This meter indicates the system operating time - it only operates when the "LAMP ON" switch is on and the indicator lamp is lit.

1.5.8 VOLT/AMP METER

This meter reads the lamp current from 0 to 100 amps, D.C. range, full time. The meter reads 0 to 100 volts D.C. - when the momentary switch, located next to the meter, is depressed.

1.6 REFLECTOR AND FOCUS MECHANISM

The reflector is mounted on the focus plate which also contains the focus mechanism. This entire assembly can be adjusted in the horizontal plane so that the reflector can be located in the center of the optical light path.

1.7 FOLDING MIRROR

The dichoric cold mirror (folding mirror) is aligned at the factory. Any adjustment of the folding mirror is discouraged unless misalignment has occurred and correction is required.

1.8 BULB ALIGNMENT CONTROLS

1.8.1 FOCUS TOOL

The tool used to focus the lamp is located in a "snap holder" on the front bulkhead. Return to holder after use.

1.8.2 LAMP FOCUS ADJUSTMENT

The lateral "LAMP FOCUS" adjustments are located below the circuit breaker panel on the operator's side and under the projector on the front of the console. These adjustments are used to center the bulb in the reflector.

1.8.3 BEAM SPREAD ADJUSTMENT

The "BEAM SPREAD" adjustment shaft is located beside the "LAMP FOCUS" adjustment on the operator's side and is used to spread the light image on the screen until desired uniformity is obtained.

SECTION 2 - INSTALLATION

2.1 RECEIVING - HANDLING

Carefully remove the console from its packing container, if used. Inspect for any shipping damage. All claims for shortages or damage occurring in transit should be filed by the customer with the freight carrier.

2.2 MECHANICAL INSTALLATION (NOT REQUIRED IN PREWIRED UNITS)

a. Before positioning the console, install the projector/soundhead on the projector/soundhead mount. Depending on the projector used, a spacer block may be required to obtain correct projector spacing (see Figure 2-1 for details).

b. For ease of installation, slots are provided in the mount to accept two mounting bolts, allowing quick initial location of the projector/soundhead.

c. The lower bolts may then be installed; check projector alignment with console; tighten the four mounting bolts.

d. If spacer blocks are required, use tape to hold them in place while installing on mount.

e. The console may now be moved into its final position.

2.3 MECHANICAL ALIGNMENT

a. The console, once in position, should be leveled - leveling feet are provided for this purpose.

b. Open back door and adjust pivot mechanism so console aligns with theater screen. (see Figure 2.2)

2.4 ELECTRICAL INSTALLATION

2.4.1 THREE-PHASE POWER CONNECTION

To connect three-phase power, remove the upper rear panel, lower rear panel and rear side panel, depending on desired wiring input. (see Figure 2-3.)

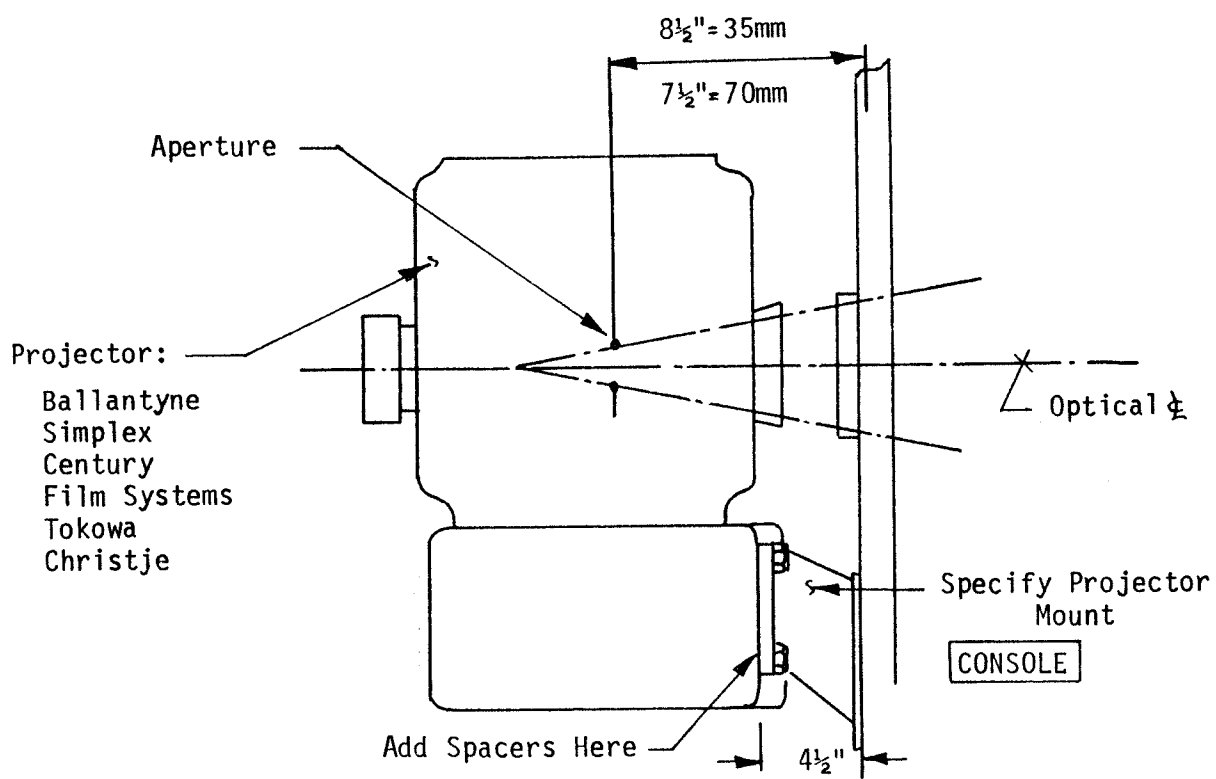

Various Projector Mounts are available from the factory.

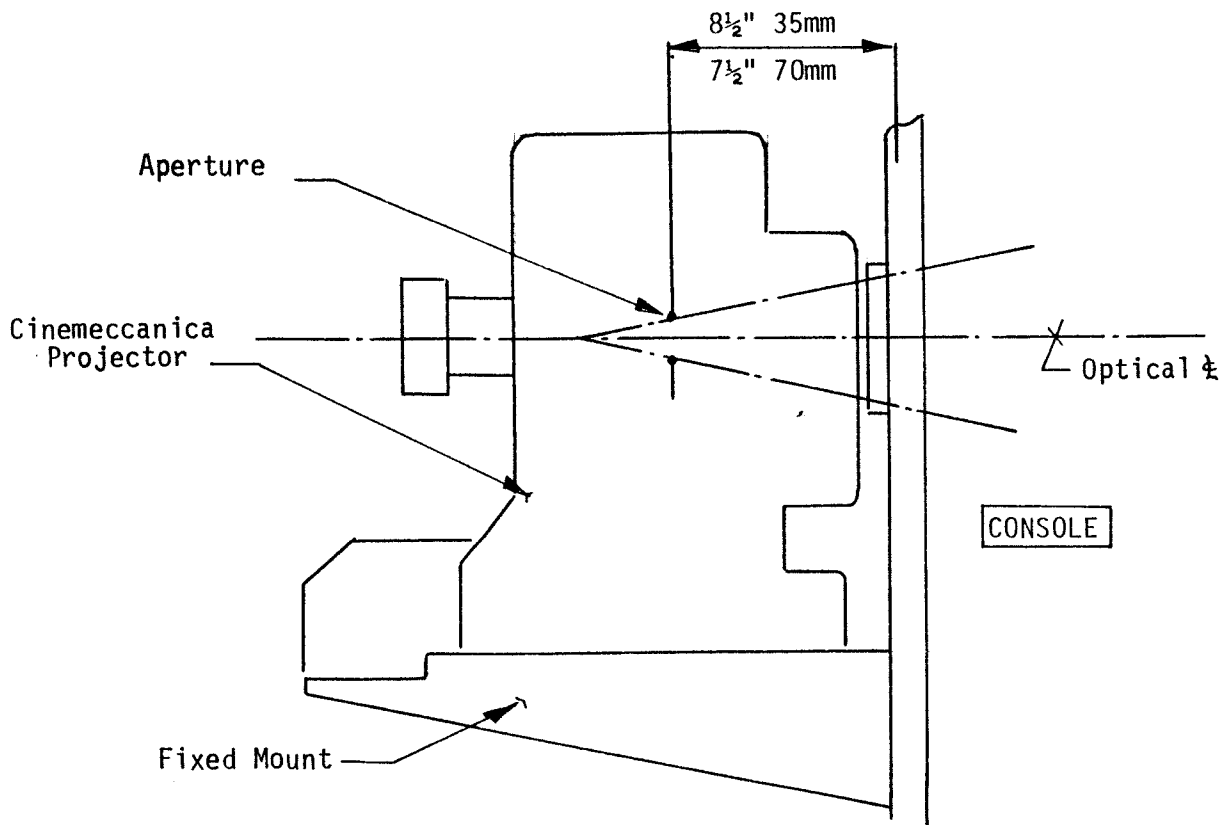

Figure 2-1. Projector Position

Locate terminal block TB-1 for 3-phase power (see Figure 2-3). Run a 4-wire (with neutral) cable from the 220 volt, 3-phase/30-amp power source to the console. Connect to TB-1 per schematic D-1001286 in back of this manual.

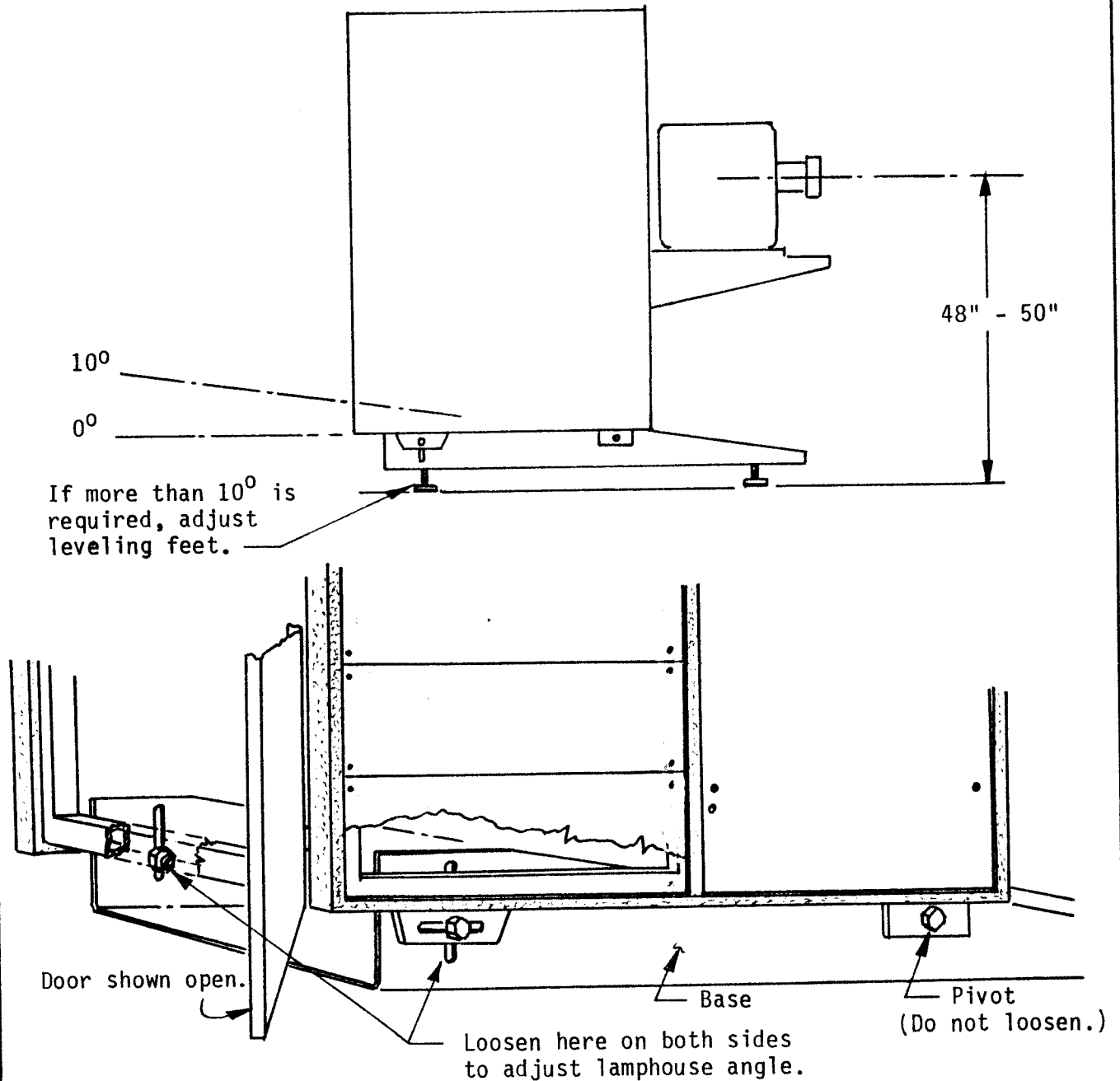

Figure 2-2. Pivot Mechanism Adjustment

See Schematic D-1001286 for Wiring Locations.

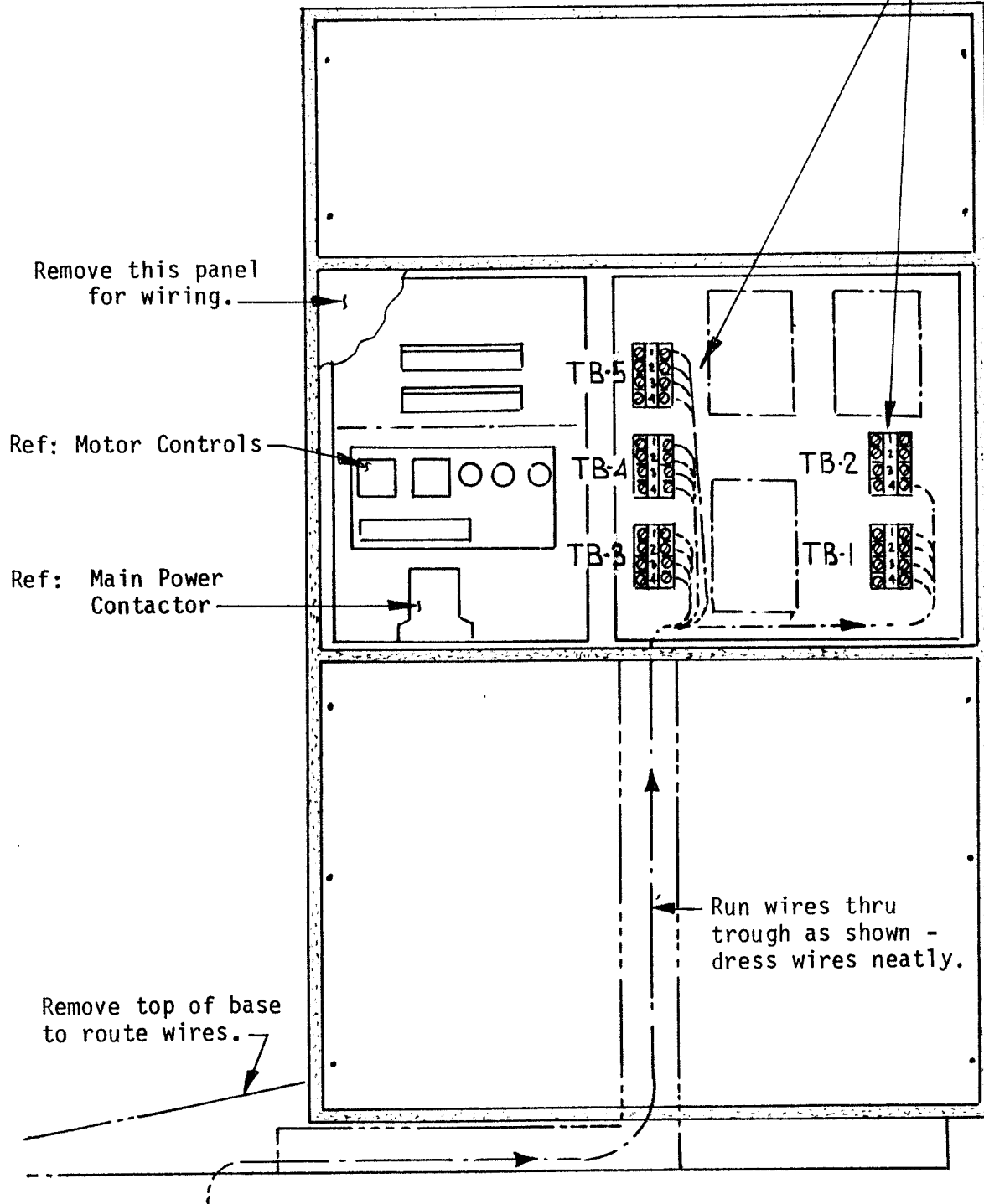

Figure 2-3. Terminal Board Locations

2.4.2 SINGLE-PHASE POWER CONNECTION

For the 115 volt single-phase service, connect the common lead from the three-phase power to TB-2 Terminal 1 (see Figure 2-3).

CAUTION

Do not connect wild leg to this terminal - equipment damage will result.

2.4.3 EXHAUST BLOWER CONNECTIONS

The console should be vented to an external exhaust blower - the blower should draw a minimum of 300 cubic feet of air per minute. When selecting and installing the exhaust system, consider the pressure drop caused by long exhaust routes. The console accepts a stock 8" diameter air conditioning duct. Connect exhaust blower leads to TB-3 terminals 1 (High) 2 (Low). Refer to Schematic D-1001286.

2.4.4 PROJECTOR MOTOR CONNECTIONS

The projector is prewired and does not require any wiring. Refer to schematics for connections.

2.4.5 BACKSTAGE LIGHTS CONNECTION

Connect backstage lights to TB-3, Terminals 3 (High) and 4 (Low).

2.4.6 CURTAIN MOTOR CONNECTION

Connect curtain motor to TB-4, Terminals 1 (High) and 2 (Low).

2.4.7 MASKING MOTOR CONNECTION

Connect masking motor to TB-4, Terminals 3 (High) and 4 (Low).

2.4.8 FILM TRANSPORT ELECTRICAL CONNECTIONS

Connect the film transport electrical connections to TB-5, Terminals 3 (High) and 4 (Low).

2.4.9 HOUSE LIGHTS CONTACTOR CONNECTIONS

Connect the house light dimmer contactor to TB-5, Terminals 1 and 2.

2.4.10 AUTOMATION CONNECTIONS

See automation manual for connections.

2.4.11 SOUND AND SPEAKER CONNECTIONS

See sound system manual.

2.5 SYSTEM WIRING PRECHECK

CAUTION

Leave rectifier circuit breakers off and do not touch "MANUAL START" button during test.

- a. Turn off all circuit breakers and switches before applying power to the input line.
- b. Turn on "LAMPHOUSE" circuit breakers,
- c. Turn on "POWER" switch - while back panel is still removed, you should see all the blowers operating and the pilot light should be on. At this time, check and see that the air flow switch (located on top blower) is functioning.
- d. Turn on "PROJECTOR" circuit breaker.
- e. Turn on "PROJECTOR" switch, projector should run.
- f. Turn on "LAMP" switch, contactors in the power supply should latch and the power supply blowers should operate.
- g. After test, turn all switches and circuit breakers off. Turn power off at source.

WARNING

Xenon bulbs are under very high pressure and can explode without warning. For this reason, always wear protective gloves, face shield, and a heavy jacket when handling the bulb outside of its protective container. Do not apply lateral pressure against the bulb during installation. Follow federal and local specifications for protective clothing whichever takes precedence. Please - follow these instructions for your own safety.

- a. Unlock the console access door with key which has been attached to the douser handle for shipment.
- b. Remove heat shield (four 1/4-turn fasteners) and set aside.
- c. Remove access panel (two 1/4-turn fasteners) located inside lamphouse. Take the xenon bulb, with its protective wrap in place, from the carton. After removal from box, check lamp for any vertical or horizontal stress cracks around neck of lamp - if any are found, do not install lamp - contact lamp manufacturer for a replacement.
- d. Loosen the two ties on wrap - but do not remove the wrap.

REMINDER

Do not exert or apply lateral pressure to lamp during installation.

- e. Insert the bulb cathode end first into the opening at the center of the reflector. Carefully feed the cathode stud into its mating receptacle below the reflector until the bulb (and adapter) are seated against the mating surface.
- f. Tighten the 5/32-inch hex-head cap screw (located in the cathode mounting block) until the xenon bulb is firmly secure.
- g. Replace access panel.
- h. Connect anode lead to anode strap. (See Figure 2.4.)

WARNING - POSSIBLE EXPLOSION HAZARD .
DO NOT APPLY LATERAL
PRESSURE TO LAMP

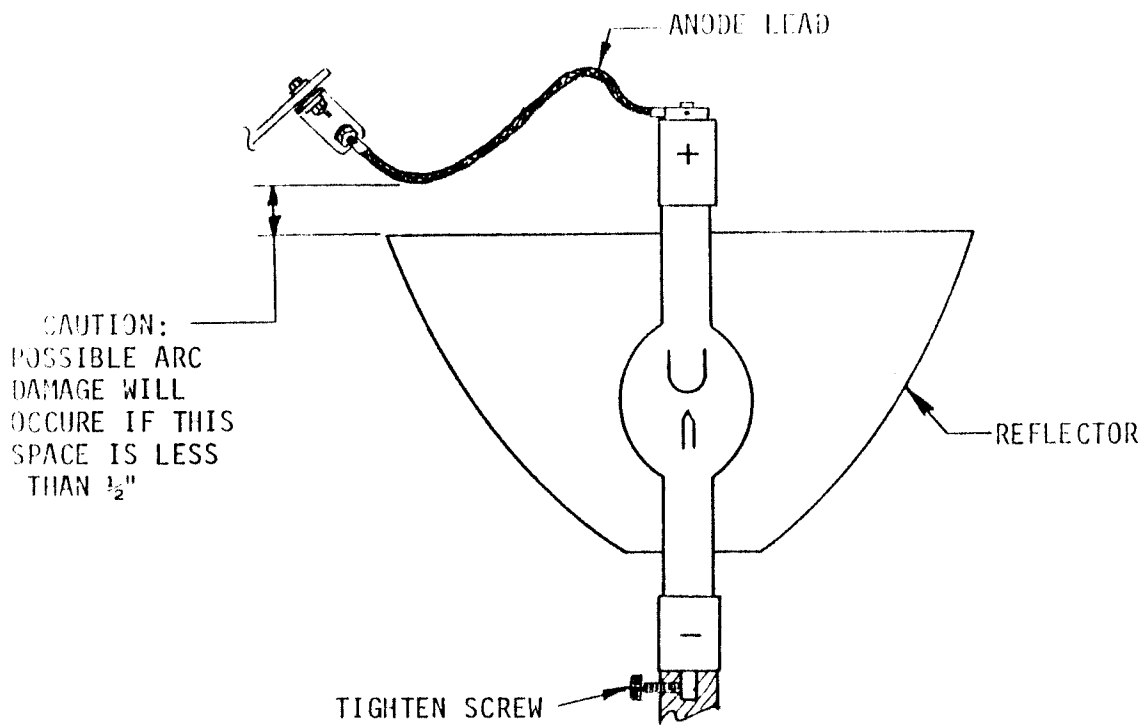

Figure 2-4. Xenon Lamp Installation

CAUTION - EQUIPMENT DAMAGE

Make sure anode lead is not touching any part of the mirror, maintain about a 1/2-inch gap between this surface or high voltage arcing and shorting may occur.

- i. Carefully remove the plastic wrap from the bulb without pulling or exerting any bending pressure on the bulb.

CAUTION - BULB DAMAGE

Avoid touching the quartz surface of the bulb with bare hands. Any body oil contamination will result in the etching of the quartz surface and could possibly cause an explosion during the lamp's operation. It is always recommended to wipe off the quartz envelope of the bulb with pure alcohol before igniting the bulb. Always wear protective clothing and read the warnings.

- j. Close the access door and lock it.

SECTION 3 - OPERATION

3.1 START-UP PROCEDURE, NEW SYSTEM

- a. Move "X" and "Y" focus adjustments to center of their adjustment range.
- b. With power off at the main panel, set current control taps on the power supply to lowest setting. This minimizes the possibility of damaging the optics during alignment. See Section 3.4 for tap adjustment procedure.
- c. Check to see that all switches and circuit breakers are in the off position.
- d. Turn on main power to the console.
- e. Close the console douser.
- f. Turn on the external exhaust blower.
- g. Turn on the "LAMPHOUSE" circuit breaker.
- h. Turn on the "POWER" switch; this applies power to the console blowers.
- i. Turn on the "RECTIFIER" circuit breakers; this applies power to the input terminals on the power supply contactors.
- j. Turn on the "LAMP" switch; the "LAMP ON" indicator light should come on and the power supplies should energize. Within three seconds, the xenon bulb should ignite.

NOTE

If the bulb fails to ignite, press the "MANUAL START" button for approximately one second. If the bulb still fails to ignite, but flashes, then shut off the power and readjust the power supply taps #1, 2, 3, 4 (fine adjust) to the next higher taps. If the bulb still fails to ignite, refer to the troubleshooting section of this manual.

1. Turn on the "PROJECTOR" circuit breaker.
- m. System is now ready to be aligned optically. See Section 3.2.

NOTE

Steps 'a' thru 'g' are not required on pre-wired systems.

3.2 OPTICAL ALIGNMENT, NEW SYSTEM

- a. Check console; it should be roughly aligned with the projector (see Figure 3-1).
- b. Projection lens and film should be removed from the projector at this point.
- c. With projector running, open the douser on the console and the projector.
- d. Open the console door.

WARNING

Xenon bulbs are under very high pressure and can explode without warning. For this reason always wear protective gloves, face shield, and a heavy jacket when handling the bulb outside of its protective container. Do not apply lateral pressure against the bulb during installation. Follow federal and local specifications for protective clothing whichever takes precedence. Please - follow these instructions for your own safety.

WARNING

Do not look directly at the xenon bulb during operation - this could cause eye damage. Always wear protective welding goggles (#6 neutral density filters minimum) when viewing the lamp.

- e. Adjust the beam spread (moves the bulb up and down). Focus the control until you get a dark circle on the screen with dark rings around it. The dark circle may or may not appear around the center of the screen.
- f. Loosen the four bolts holding the reflector mounting plate and move the plate around until the dark circle is centered on the screen - tighten down the four mounting bolts.
- g. Close the douser and replace the projection lens.

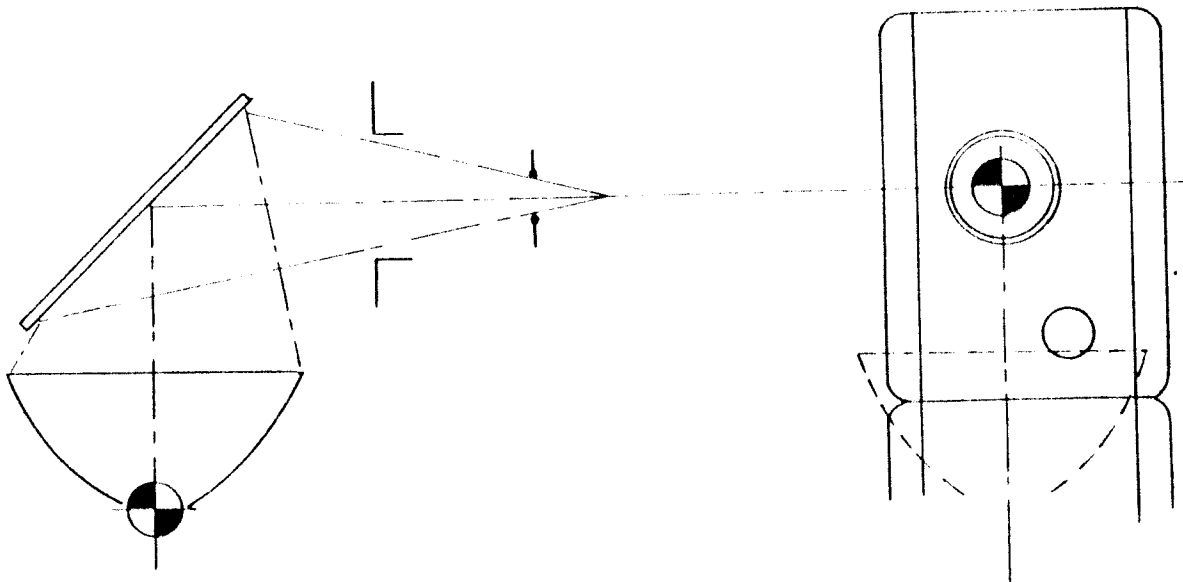

Figure 3-1 Projector Alignment

CAUTION - PROJECTION LENS DAMAGE

Do not allow the projection lens to be exposed to the light for more than a few seconds at a time without film in the projector. Use the console douser to control the light timing. Allow the projection lens to cool between adjustment observations. Extended exposure to the light without running film will cause the projection lens to overheat and break the lenses.

- h. Open the douser and focus the projection lens.
- i. Adjust the "beam spread" control until the corners on the screen become dark.
- j. Adjust the "X" and "Y" focus adjusts until the dark corners of the screen are equal in size and shape.
- k. Adjust the beam spread until the dark rings disappear and the light spreads out to the desired uniformity required. Use a light meter, if available, to fine tune the light uniformity. See pages 3-3a thru 3-3c for light measurement data.

American National Standard specifications for screen luminance for indoor motion-picture theaters

Approved October 9, 1970

Sponsor: Society of Motion Picture and Television Engineers, Inc.

Page 1 of 2 pages

1. Scope

This standard specifies the luminance level on the projection screen for indoor theaters.

2. Purpose

The purpose of this standard is to specify luminance levels at which tone scale, contrast, and pictorial quality of the projected image from release prints will be of the quality anticipated during their production.

3. Measurement

3.1 Measurement of screen luminance and color of projection light is made with the projector in complete operation with its lens set at focus position, but with no film in the aperture.

3.2 Screen luminance shall be measured with a photometer having the spectral luminous efficiency of the standard observer (photopic vision), as defined in Section 3.7.2 of American National Standard Nomenclature and Definitions for Illuminating Engineering, Z7.1-1967. The acceptance angle of the photometer shall be 2 degrees or less (See Appendix A5).

4. Luminance Level

4.1 The distribution of projection illumination shall be symmetrical about the geometric center

of the screen, and the luminance shall be 16 ± 2 footlamberts (fL) [55 ± 7 candelas per square meter (cd/m^2)], as measured from a position on the seating area centerline.

4.2 The luminance for any point on the horizontal axis within the distance of 5 percent of the screen width from the side edges shall not be less than 10 fL ($34 \text{ cd}/\text{m}^2$), as measured from either of two points in the middle row of the auditorium opposite the edges of the screen and one half the screen width from the center of the auditorium.

5. Multiple Projector Adjustment

5.1 The resultant luminance from all projectors intended for use in the continuous viewing of material of a similar format shall not vary by more than 2 fL ($7 \text{ cd}/\text{m}^2$), as measured in 4.1 above.

5.2 The resultant luminance from projectors intended for use in a sequential system of viewing material of different formats shall not vary by more than 4 fL ($14 \text{ cd}/\text{m}^2$), as measured in 4.1 above.

5.3 The apparent color of the projection light from projectors intended for interchangeably sequential operation shall be consistent within a range of no more than 400°K.

Appendix

(The Appendix is not a part of this American National Standard, but is included to facilitate its use.)

A1. Standard Luminance

Possible luminance levels are limited by a minimum value below which the visual process becomes less efficient, and by a maximum value above which flicker be-

comes objectionable. Permissible luminance range is limited by the criterion that a good release print must provide acceptable quality when projected at any luminance within the range.

CAUTION NOTICE This American National Standard may be revised or withdrawn at any time. The procedures of the American National Standards Institute require that action be taken to reaffirm, revise, or withdraw this standard no later than five (5) years from the date of publication. Purchasers of American National Standards may receive current information on all standards by calling or writing the American National Standards Institute, 1430 Broadway, New York, N.Y. 10018. Printed in USA

A2. Other Variables

In addition to the luminance distribution, the pictorial quality of projected pictures is influenced by the color of the projection light, the color and characteristics of the screen surface, the presence of stray light, the nature of the surround, and other factors not presently described by standards. It should be noted that stray light, the use of light-colored framing, and the adaptation of unmasked screens may contribute to reflections on the screen which will affect contrast.

Stray light includes non-image-forming light, such as lens flare, re-reflected projection light, ambient light, etc. Since the factors responsible for such stray light do not change unexpectedly, it will usually be sufficient to make stray light measurements at intervals. Stray light can be measured by comparing the screen luminance with the luminance of the image of an opaque test object placed in the center of the projector aperture. The test object preferably should have a diameter of 0.050 in. (5 percent of frame width) and should not exceed 0.100 in. The balance of the projected beam is attenuated by any suitable neutral density film that produces through the normal projection system an average screen luminance equal to 10 percent of the luminance of the screen as defined in 4.1. All sources of illumination in the auditorium, such as exit and aisle light, shall be used in their normal manner while stray light is being measured. Adjustment of stray light conditions should cause the measurement of luminance to be no more than 0.5 percent of the screen luminance at the center of the screen as measured in 4.1.

A3. Directional Screens

Matte white screens will show substantially constant luminance at any one specific area on the screen for measurements from any location in the theater. Directional screens have been designed to produce specific patterns which reflect the projection light in a controlled manner to the useful areas of the auditorium. It is intended that the standard apply to either matte white or directional screens regardless of whether they are curved or flat.

A maximum permissible variation is given in 4.2. In a particular theater, this condition can be met by several procedures, including one or more of the following: choice of a screen with a suitable reflection pattern; limitation of the seating area so that no patron views the picture from an angle at which the luminance is outside the tolerance of the standard, and screen curvature. No stray light or illuminated area with a luminance in excess of 1 fL (3.4 cd/m²) shall be visible from the standard observing area.

A4. Release Prints

Release prints intended for viewing in theaters adjusted in accordance with this standard should be examined or checked under the conditions specified in American National Standard Screen Luminance and Viewing Conditions for 35mm Review Rooms, PH22.133-1963 (Reaffirmed 1969).

A5. Luminance Photometer

The measurement of luminance with uncertainty of less than 10 percent requires a good photometer. Since there are no true Lambertian surfaces, and even the theatrical "matte screens" may depart by more than 10 percent, the brightness will vary with the angle of observation. A photometer having a large field angle will indicate the average luminance within its field, and if this includes a large area of the screen (or of the screen and surround), this average may be substantially different from the observed brightness. It has been found that within the geometric restrictions under which photometers are used in theaters, their luminance indication correlates well with the observed brightness if the field angle of the photometer is about 2 degrees or less.

A photometer having a small field angle may receive light from such a small screen area as to detect luminance differences due to defects in the screen, imaging of the projection source, etc. When measuring the luminances required in 4.2, the luminances of immediately adjacent areas should be observed to be sure the reading is relevant.

The influences of surround brightnesses on the measured luminance must be excluded. Smoke, dust, and atmospheric haze have an obvious effect on the measurement. But flare and reflections within the optical system of the photometer may cause large errors that are difficult to isolate. One method of checking the instrument consists of measuring the luminance of a dark surface both with and without an adjacent bright source. These measurement errors are functions of both the instrument and of the directional luminances of the theater. They cannot be removed by calibration unless the photometer is separately calibrated for each type of installation to be encountered.

The manufacturer of the photometer should specify the errors to be expected from the above and other causes, and prescribe the limiting conditions for reliable use of the instrument.

A6. Conversion of Units

Screen luminance in the U.S. is customarily measured in footlamberts, although in the International System of Units (SI Units), the candela per square meter is the preferred unit. One candela per square meter equals 0.2919 footlamberts; 1 footlambert equals 3.426 candelas per square meter. The name "nit" is sometimes applied to the unit of luminance instead of candela per square meter.

THEATER SCREEN LIGHT CHECKING PROCEDURE *

FORM NO. 2—INCIDENT SCREEN LIGHT MEASUREMENT

THEATER _____ DATE _____

ADDRESS _____ REPORTED BY _____

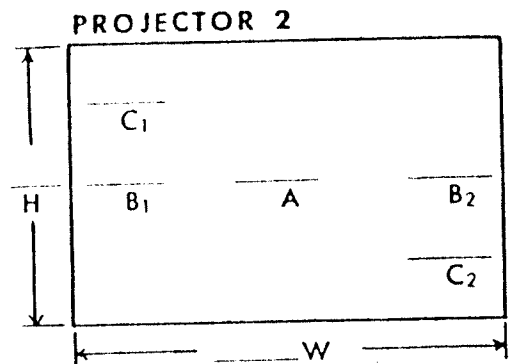
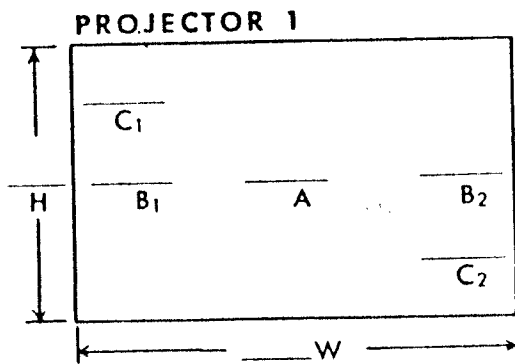

Notes

- (a) "C₁" and "C₂" are located approximately 1/20 of H from the top and bottom edges, and 1/20 of W from sides. "B₁" and "B₂" are on the horizontal center and 1/20 of W from sides. "A" is in the exact center.
- (b) These measurements were made with a standard aperture in the projector.
- (c) On standard screens the ratio of H to W is .73 (H/W = .73). Therefore you may measure the width of your screen (if not known) and to find the height (H) just multiply width (W) by .73. Similar constants can be calculated for other aperture ratios.
- (d) Readings are to be taken without any film in the gate.
- (e) All readings are made by holding the light meter parallel to and a few inches away from the screen, and facing the beam of light.

Screen Area

Area in square feet = $H \times W =$ (1)

Screen Light Intensity and Distribution

Side-to-Center ratio $\frac{B_1 + B_2}{2} \times \frac{1}{A} =$

Corner-to-Center ratio $\frac{C_1 + C_2}{2} \times \frac{1}{A} =$

Screen Lumen Calculation

$A \times 2 =$
 $B_1 + B_2 =$
 $C_1 + C_2 =$

 2
 Total =

Weighted Avg. = $\frac{\text{Total}}{5} =$ (2)

Screen Lumens = (1) \times (2) = (3)

Screen Lumens without shutter = (3) \times 2 = (4)

Screen Area

Area in square feet = $H \times W =$ (1)

Screen Light Intensity and Distribution

Side-to-Center ratio $\frac{B_1 + B_2}{2} \times \frac{1}{A} =$

Corner-to-Center ratio $\frac{C_1 + C_2}{2} \times \frac{1}{A} =$

Screen Lumen Calculation

$A \times 2 =$
 $B_1 + B_2 =$
 $C_1 + C_2 =$

 2
 Total =

Weighted Avg. = $\frac{\text{Total}}{5} =$ (2)

Screen Lumens = (1) \times (2) = (3)

Screen Lumens without shutter = (3) \times 2 = (4)

*Excerpted from "Motion-Picture Projection and Theatre Presentation Manual," Society of Motion Picture and Television Engineers, Inc., Scarsdale, N.Y., published 1969. 3-3c

1. Close the console douser and turn the "LAMP" switch off. Leave the "POWER" switch on for about ten minutes to cool the lamp properly.
- m. Turn off the projector.
- n. Close the console access door and lock it. Replace any panels removed during initial installation.
- o. Turn off "POWER" switch.
- p. Turn off all circuit breakers.
- q. Adjust current control taps on power supplies to obtain desired screen brightness.

CAUTION - BULB DAMAGE

Do not exceed maximum safe current for bulb. The lower the current at which the lamp runs to obtain desired brightness will increase the bulb life substantially.

3.3 OPTICAL ALIGNMENT (AFTER BULB REPLACEMENT)

- a. Install the new bulb as outlined in Section 2.8.
- b. Repeat steps 3.1b thru 3.1m.
- c. Repeat steps 3.2b, e, g thru 3.2r.

NOTE

It is not necessary to align a new bulb with the access door open - leave this door closed during alignment.

3.4 VOLTAGE TAP ADJUSTMENTS

- a. Remove front voltage tap access panel and locate voltage taps marked "W, X, Y, Z" and "1, 2, 3, 4." The "W, X, Y, Z" taps are for coarse adjustment, and the "1, 2, 3, 4" taps are for fine adjustment (see Figure 3-2).
- b. Shut off all power to console prior to adjusting current control taps.
- c. Adjust taps to meet screen brightness requirement - do not exceed lamp current ratings. Adjust taps equally on each power supply. Make sure all three wires are on the same tap designation.

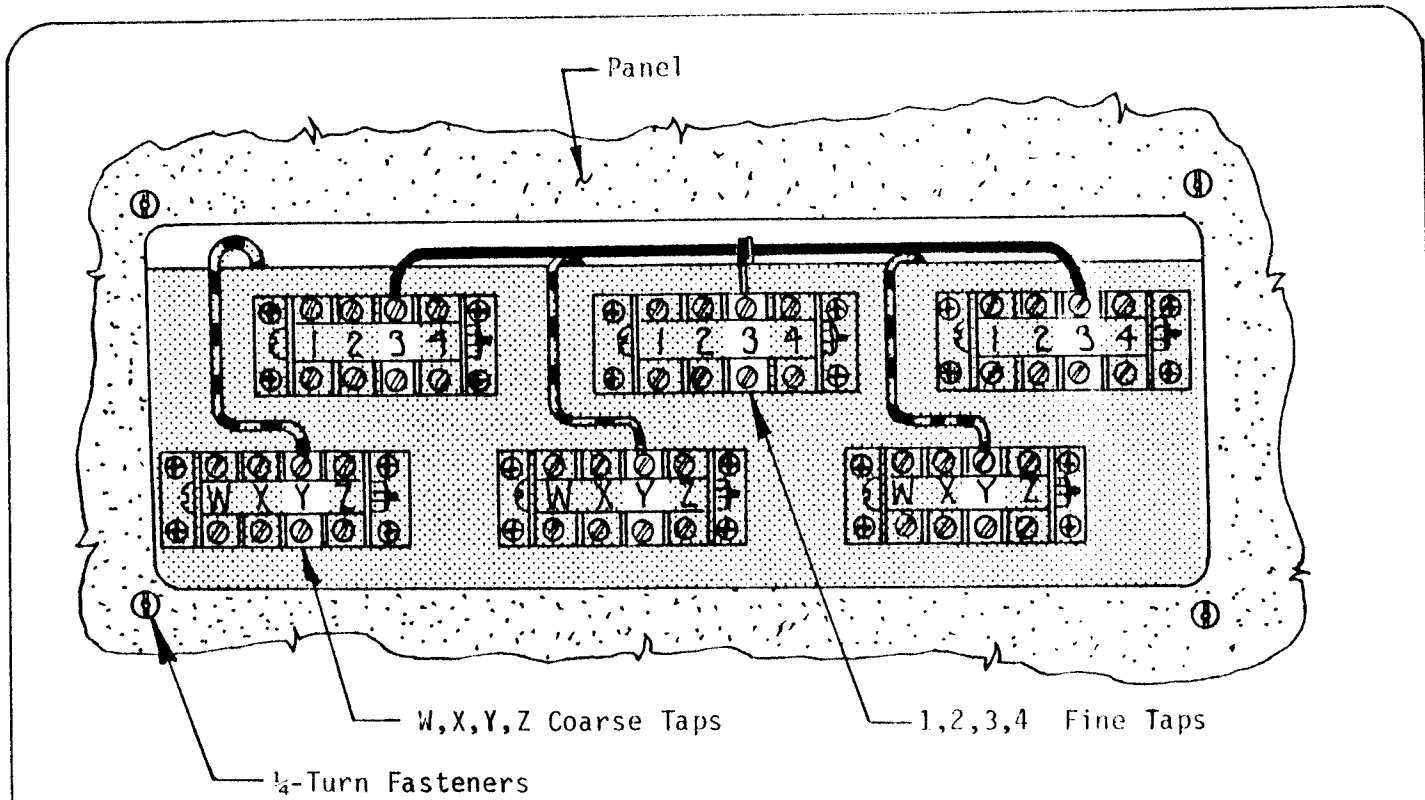

Figure 3-2. Voltage Tap Locations

CAUTION

When setting taps, do not exceed specified current requirements of xenon lamp being used. Bulb damage or shortened lamp life will occur.

- d. Once proper current levels are obtained, replace access panels on the console.

3.5 START-UP PROCEDURE, ALIGNED SYSTEM

- a. Turn on all circuit breakers.
- b. Turn on exhaust blower.
- c. Turn on "POWER" switch
- d. Turn on "LAMP" switch, lamp should light within three seconds.

NOTE

If the bulb fails to ignite, press the "MANUAL START" button for approximately one second. If the bulb still fails to ignite, but flashes, then shut off the power and readjust the power supply taps #1,2,3,4 (fine adjust) to the next higher taps. If the bulb still fails to ignite, refer to the troubleshooting section of this manual.

3.6 SHUT-DOWN PROCEDURE

- a. Turn off "LAMP" switch. Leave on exhaust blower and "POWER" switch for 15 minutes to allow system to cool properly.
- b. After 15 minutes shut off exhaust blower.

SECTION 4 - MAINTENANCE

4.1 CLEANING OF OPTICS



Disconnect all power when servicing the lamphouse console.

- a. As required, or at least every three to four months, the optics should be cleaned.
- b. It is recommended that a glass cleaner or other very mild solution be used in cleaning the optics.
- c. The bulb should be removed while cleaning the reflector (see Section 2.8 for bulb removal).

4.2 BLOWERS

The blowers should be oiled every six months per manufacturer's instructions enclosed in the back of this manual.

4.3 GENERAL CONDITION

At least once a year the console should have all its panels removed and vacuumed out. Remember to remove all power to the lamphouse when working inside. Check condition of hoses and wiring for ultraviolet exposure and replace any questionable items. Check all high voltage leads for tightness and inspect connections for any sign of overheating. If connections have been overheating, take them apart and clean them with a wire brush. Once cleaned, the connections should be replaced and tightened.

SECTION 5 - TROUBLESHOOTING

In the event of any troubleshooting questions, consult the schematic diagrams and engineering drawings enclosed in Section 6 of this manual as guides for determining how to service the console system.

Symptom

1. Lamp does not ignite automatically, but starts immediately with MANUAL START switch depressed.

Probable Cause

- a. Insufficient open circuit voltage.
- b. Igniter adjustment improperly set.
- c. Open zener diode.
- d. Open igniter relay coil (K1).
- e. Defective igniter adjustment control.

Remedy

- (1) Open circuit voltage should measure approximately 120 VDC if low power transformer taps are too low. Adjust taps to a higher setting.
- (2) Check coil on relay (K1). If open, replace.
- (3) If coil is good, measure DC voltage across coil when trying to start automatically. Voltage will rise to approximately 27V and relay contacts will close.
- (4) If lamp still fails to ignite, check zener diode for open circuit. If found defective, replace. (Observe diode polarity.)
- (5) If relay is good and coil voltage is low, check igniter relay voltage adjustment control. Turn control fully clockwise and turn lamphouse power on. Adjust control counter clockwise until lamp ignites. Check lamp for consistent ignition. Lamp should ignite whether it is hot or cold.

Symptom

2. Lamp does not ignite automatically and requires several MANUAL START switch depressions, to ignite.

Probable Cause

- a. Aging bulb.
- b. Incorrect igniter adjustment.
- c. Power supply taps set too low, start voltage less than 100 VDC.
- d. Faulty MANUAL START switch.
- e. Faulty spark gap.
- f. Burnt out HV transformer.
- g. Shorted RF transformer.

Remedy

- (1) Open lamphouse door (wear protective clothing and eye protection). Remove 3 cover screws on igniter cover and remove cover. Turn power supply power circuit breakers to OFF position. Turn system On switch to ON position. Turn lamp On switch to ON position. CAUTION: STAND CLEAR OF IGNITER OUTPUT BECAUSE OF HIGH VOLTAGE DANGER.

Momentarily depress MANUAL START switch and observe spark across the bulb and "spark gap" located inside the igniter.

WARNING

Only hold the manual start button in for a second, prolonged engagement will destroy the transformer inside of the igniter.

If spark is strong across spark gap and weak across lamp, then bulb or RF transformer is faulty. Replace bulb first. If it does not correct situation, replace the RF transformer or entire igniter. If spark is weak across both bulb and spark gap, then either spark gap or H.V. transformer is defective and will also require replacement of igniter.

- (2) Remove side panel (opposite door) and place voltmeter across terminals #1 and 4 on igniter. Meter should show 115 VAC (220 VAC on 50 HZ systems) each time manual start is depressed. If not, manual start switch is bad and should be replaced. Check Symptom 1 for automatic ignition.

- (3) If spark is strong at both the spark gap and bulb on each depression of the MANUAL START switch, replace bulb, check power supply circuit breaker or incoming 3 ϕ power, check power supply DC output.

Symptom

3. Bulb starts automatically
but not manually.

Probable Cause

a. Faulty MANUAL START switch.

Remedy

(1) Replace switch.

Symptom

Probable Cause

4. Bulb does not start at all.

- a. No interlock closure.
- b. Defective power contactor.
- c. No 3 Ø power to power supply.
- d. No control power to lamp house.
(115 VAC)
- e. Loose connection.
- f. Faulty igniter.
- g. Fractured electrode in bulb.
- h. Circuit breaker open on lamphouse
or power supply.

Remedy

- (1) If power supply fan comes on and red INTERLOCK light does not go out, then the lamphouse fan interlock is not closed. Make sure flow switch paddle is not loose in the flow switch. If it is loose, then take off cover and re-engage paddle. Bulb should then start. If no restrictions are on the lamphouse exhaust, then bend flow inward switch arm slightly until closure occurs and bulb starts.
- (2) Check 3 Ø power to power supply.
- (3) If fan does not start in lamphouse, then there is no control power to lamphouse. Check voltage at TB2 terminals. If voltage exists, check circuit breaker in lamphouse.
- (4) If power exists to both power supply and lamphouse, then check connection on terminals 1 and 2 in power supply. If red INTERLOCK open light goes out, fan does not start in power supply, first check circuit breakers to power supply to make sure they are engaged. If engaged, measure voltage at terminals 1 and 2 in power supply. It should read 115 VAC (220V for 50 HZ Model). If it does and power supply fan is not running and no DC open circuit voltage exists across DC output terminals (approx. 120 VDC), the circuit breaker is faulty.

- (5) If power supply fan is running and an open circuit voltage of approximately 120 VDC exists, then the igniter is probably faulty. Open lamphouse door, remove igniter cover and observe the transformer and RF transformer. If either appears to be charred, then the igniter should be replaced and zener diode D-1 checked and probably replaced. If the transformer is charred, then the igniter was probably on continuously, indicating that D-1 is shorted. If transformers appear to be good, then refer to remedy procedures of Symptom 2 covering the faulty spark gap, shorted RF transformer and aging bulb.

Symptom

Probable Cause

5. Popping sound in lamphouse during ignition of bulb.

- a. HV arc over.
- b. Loose DC connection in power supply or lamphouse.
- c. HV breakdown on connection to anode end.

Remedy

- (1) Check output terminal on RF transformer for signs of arcing to metal.
- (2) Check small hole in reflector for signs of arcing from bulb starting wire to hole in mirror edge. If signs exist, rotate bulb 180°.
- (3) If HV breakdown occurs on cathode end around area of lamp support casting on center focus adjustment; check all DC power connections in lamphouse and power supply, including bulb end connection. Tighten securely. If problem still exists, take off power supply cover and check DC connection internal to power supply on chokes, capacitors and full wave bridge rectifiers. Loosen connections on rectifiers and retighten.
- (4) If arcing occurs around anode end, check that bulb lead's closeness to metal surfaces is a 2" minimum distance

Symptom

6. Flickering light output.

Probable Cause

- a. Unstable bulb.
- b. Power supply taps set too low.
- c. Faulty rectifier in full wave bridge.

Remedy

- (1) Replace bulb. If flicker does not go away with new bulb, then check each power supply diode for open circuit, being careful to disconnect one lead off each diode while checking. Replace faulty diode.

Symptom

7. Bulb goes out during operation.

Probable Cause

- a. Circuit breaker on rectifier and lamphouse.
- b. Fuse or breaker in wall.
- c. Thermal overload in power supply.
- d. Faulty bulb.
- e. Defective airflow switch.

Remedy

- (1) Check circuit breakers on rectifier and lamphouse.
- (2) Check fuses or breakers on wall. Be careful - fuses can give signs of having continuity when they are really open.
- (3) Check to see if fan operates in power supply. If fan does not operate, then thermal overload will shut system off.
- (4) Check bulb for leak. Bulb will be dark blue if leaking. Check for fractured cathode. Replace bulb.

Symptom

8. DC current increases steadily.

Probable Cause

a. Leaky seal on bulb.

Remedy

(1) Replace bulb. Bulb will have turned dark blue or milky white. Electrodes, if visible, will be heavily oxidized and probably green in color.

Symptom

9. Film too hot.

Probable Cause

a. Improper lamphouse alignment.

Remedy

(1) Align lamphouse to projector and screen properly.

Symptom

10. System does not shut off from lamphouse power on switch.

Probable Cause

- a. Faulty switch.
- b. If wired to an automation system, check for defective automation relay.

Remedy

- (1) Replace switch.
- (2) Correct faulty automation.

Symptom

11. Indicator lamps out on lamphouse.

Probable Cause

- a. Burned out indicator lamp.
- b. Defective air flow switch.
(interlock lamp only)

Remedy

- (1) Replace with new lamp.
- (2) Replace air flow interlock switch.

SECTION 6

DATA SHEETS

AND

DRAWINGS

MODELS 2C610, 2C915A & 4C442

ORDER REPLACEMENT PARTS THROUGH DEALER FROM WHOM PRODUCT WAS PURCHASED

If dealer cannot supply order from:

Dayton Electric Mfg. Co.
CUSTOMER SERVICE DEPT.
5959 W. Howard St.
Chicago, Illinois 60648

Please provide following information:

- Model Number
- Serial Number (if any)
- Part Description and Number as shown in Parts List

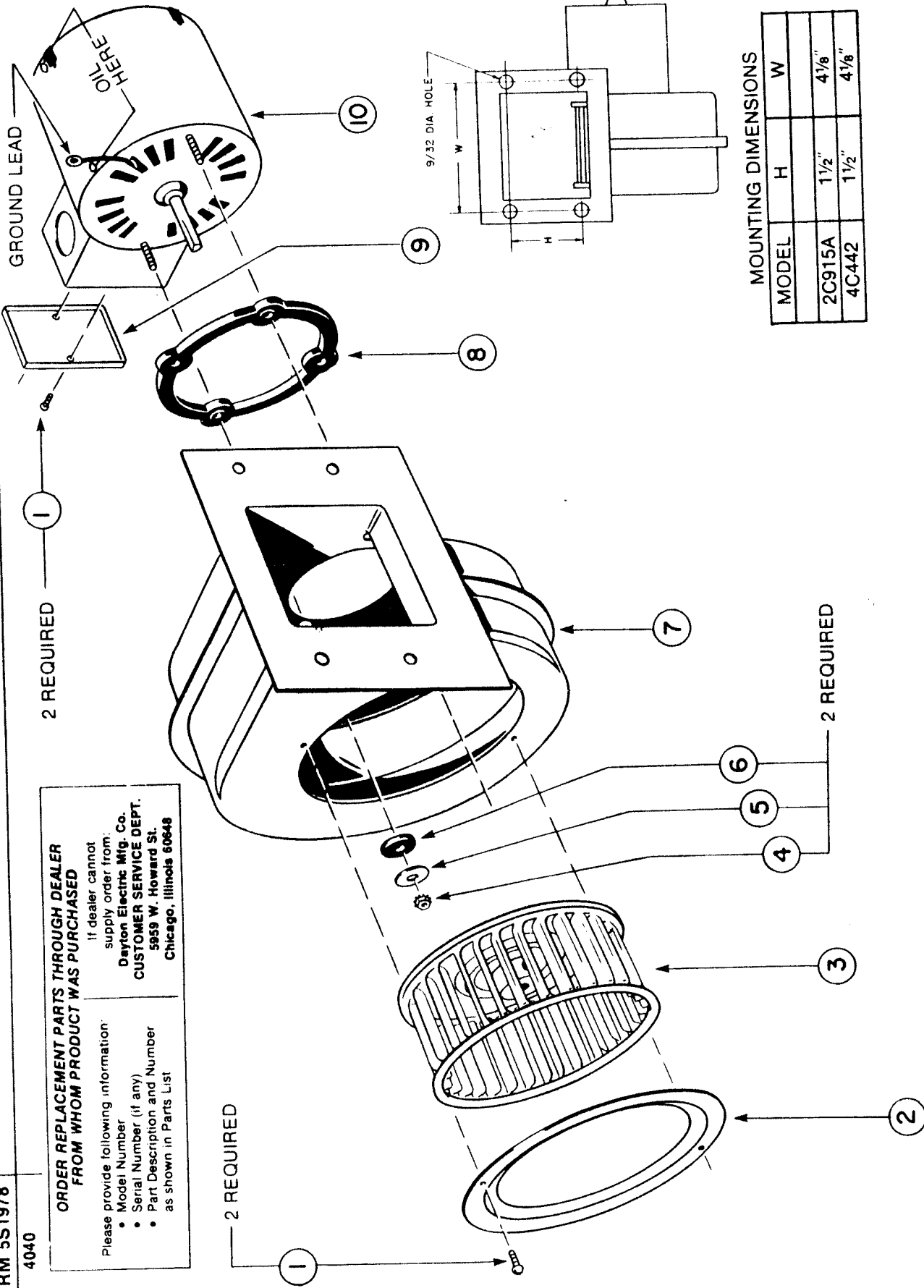

MOUNTING DIMENSIONS

MODEL	H	W
2C915A	1 1/2"	4 1/8"
4C442	1 1/2"	4 1/8"

Figure 3 — Exploded-View Illustration and Mounting Dimensions

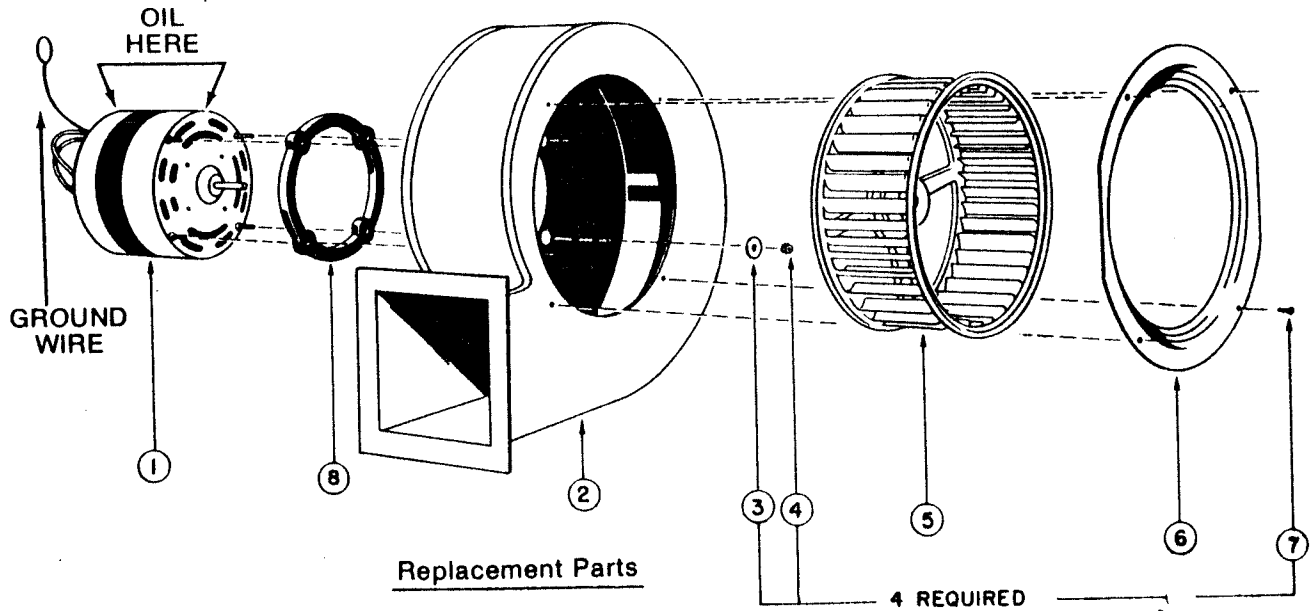

Specifications and Performance Chart

MODEL	SPECIFICATIONS										PERFORMANCE								
	WHEEL SIZE		MOTOR			OUTLET OPENING		OVERALL DIMENSIONS			CFM AIR DELIVERY AT SPEED AND STATIC PRESSURE (SP) SHOWN					WATTS	AMPS		
	DIA.	W	HP	SPEED	PWR. REQD.	H	W	H	W	D	Free Air	0.1" SP	0.2" SP	0.3" SP	0.4" SP			0.5" SP	SPEED
2C917A Δ	6 5/16"	2 7/8"	1/12	1	200V 50/60 Hz	4 5/16"	3 25/32"	11 1/8"	7 27/32"	10 5/16"	350	340	328	312	296	274	1585*	186	1.45
4C444 Δ	6 5/16"	2 7/8"	1/12	1	115 V 50/60 Hz	4 5/16"	3 25/32"	11 1/8"	7 27/32"	10 5/16"	350	340	328	312	296	274	1585*	185	2.90

Δ Automatic-Reset Thermal Protection

NOTE: All data based on 60 Hz operation. Units capable of operating on 50 Hz will have approximately a 20% decrease in flow rate performance.

*At Free Air

Replacement Parts List

Ref. No.	Description	Part Numbers for Model	
		2C917A	4C444
1	Motor	7108-2661	7108-2659
2	Housing	8853-0300	8853-0300
3	Washer	0610-0033	0610-0033
4	Mounting Nut	0010-0021	0010-0021
5	Blower Wheel	0913-0010	0913-0010
6	Inlet Ring	8793-0803	8793-0803
7	Mounting Screw	0610-0069	0610-0069
8	Gasket	0913-0008	0913-0008



INSTALLATION INSTRUCTIONS & PARTS LIST

SHADED-POLE BLOWERS

MODELS 2C915A, & 4C442

FORM 5S1978 4040

DAYTON ELECTRIC MANUFACTURING CO. CHICAGO 60648

0779/348/15M 2B

ATTENTION: READ CAREFULLY BEFORE ATTEMPTING TO INSTALL, OPERATE OR SERVICE YOUR DAYTON SHADED-POLE BLOWER. RETAIN FOR FUTURE REFERENCE!

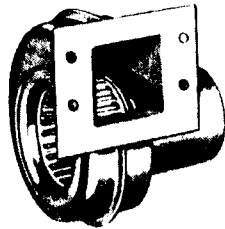

Figure 1 — Shaded-Pole Blower

Description

Your Dayton shaded-pole blower, finished in grey enamel, is a single speed unit designed specifically for heating, cooling, exhausting, ventilating and drying. It is field interchangeable with most direct drive blowers and can be mounted in any discharge position. Blower is driven by a shaded-pole motor.

Models 2C915A and 4C442 feature automatic-reset thermal protection which automatically shuts off the motor should excessive temperatures develop.

For additional information, see Specifications and Performance Chart.

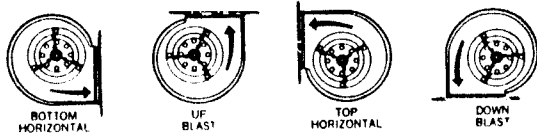

Figure 2 — Typical Installation Discharge Positions

General Safety Information

1. Follow all local electrical and safety codes, as well as the National Electrical Code (NEC) and the Occupational Safety and Health Act (OSHA).
2. Blower must be securely and adequately grounded. This can be accomplished by wiring with a grounded, metal-clad raceway system, by using a separate ground wire connected to the bare metal of blower frame, or other suitable means.
3. Always disconnect power source before working on or near a motor or its connected load. If the power disconnect point is out-of-sight, lock it in the open position and tag to prevent unexpected application of power.
4. Be careful when touching the exterior of an operating motor — it may be hot enough to be painful or cause injury. With modern motors this condition is normal if operated at rated load and voltage — modern motors are built to operate at higher temperatures.
5. Protect the power cable from coming in contact with sharp objects.
6. Do not kink power cable and never allow the cable to come in contact with oil, grease, hot surfaces, or chemicals.
7. Make certain that the power source conforms to the requirements of your equipment.
8. Wiping or cleaning rags and other flammable waste materials must be placed in a tightly closed metal container and disposed of later in the proper fashion.
9. When cleaning electrical or electronic equipment, always use an approved cleaning agent such as dry cleaning solvent.

Specifications and Performance Chart

MODEL	SPECIFICATIONS										PERFORMANCE								
	WHEEL SIZE		MOTOR			OUTLET OPENING		OVERALL DIMENSIONS					CFM AIR DELIVERY AT SPEED (RPM) AND STATIC PRESSURE (SP) SHOWN					WATTS	AMPS
	DIA.	W	HP	SPD	PWR REQD	H	W	H	W	D	FREE AIR	0.1 SP	0.2 SP	0.3 SP	0.4 SP	0.5 SP	RPM		
2C915A Δ	3-13/16	1-7/8	1/30	1	230V 50/60 Hz	2 1/2	2 1/2	7-7/32	6-9/32	6-3/4	FREE AIR	0.1 SP	0.2 SP	0.3 SP	0.4 SP	0.5 SP	RPM	80	0.51
											140	136	131	125	119	110	3020*		
4C442 Δ	3-13/16	1-7/8	1/30	1	115V 50/60 Hz	2-1/2	2 1/2	7-7/32	6-9/32	6-3/4	FREE AIR	0.1 SP	0.2 SP	0.3 SP	0.4 SP	0.5 SP	RPM	80	1.02
											140	136	131	125	119	110	3020*		

Δ Automatic Reset Thermal Protection

NOTE All data based on 60Hz operation. When operated on 50 Hz, a decrease of approximately 20% will occur in flow rate performance.

* At Free Air

Installation

Maintenance

1. Mount the unit in the position most desirable to your needs.
2. Connect the leads to the appropriate power source.

CAUTION: A GROUND WIRE MUST RUN FROM THE BLOWER MOTOR HOUSING TO A SUITABLE ELECTRICAL GROUND SUCH AS A PROPERLY GROUNDED METALLIC RACEWAY OR GROUND WIRE SYSTEM.

3. Unit is ready for operation.

CAUTION: ALWAYS DISCONNECT POWER SUPPLY BEFORE SERVICING THE BLOWER OR WORKING WITH THE UNIT FOR ANY REASON. THIS IS ESPECIALLY IMPORTANT WITH UNITS EQUIPPED WITH AUTOMATIC-RESET THERMAL PROTECTION — UNIT MAY ACTIVATE WITHOUT WARNING!

The motor should be relubricated every 6 months with 10 to 20 drops of SAE 10W or 20W non-detergent oil (ML-type) or with electric motor oil.

Should further servicing of the unit be necessary, refer to the "exploded" view illustration as an aid in disassembly and assembly procedures.

Service Record

DATE	MAINTENANCE PERFORMED	COMPONENTS REQUIRED

Trouble Shooting Chart

SYMPTOM	POSSIBLE CAUSES	CORRECTIVE ACTION
Excessive Noise.	<ol style="list-style-type: none"> 1. Blower wheel contacting housing. 2. Foreign material inside housing. 3. Leak in duct work. 4. Loose duct work. 	<ol style="list-style-type: none"> 1. Realign or replace. 2. Clean. 3. Repair. 4. Secure properly.
Insufficient air flow.	<ol style="list-style-type: none"> 1. Leaks in duct work. 2. Dampers and/or registers closed. 3. Obstruction in system. 4. Clogged Filters. 	<ol style="list-style-type: none"> 1. Repair. 2. Open. 3. Remove. 4. Clean or replace.
Unit fails to operate.	<ol style="list-style-type: none"> 1. Blown fuse or open circuit breaker. 2. Defective motor. 3. Automatic-Reset thermal protector "tripped". 4. Motor improperly wired. 	<ol style="list-style-type: none"> 1. Replace fuse or reset circuit breaker. 2. Replace. 3. Check for high (or low) voltage input or ambient temperatures in excess of 40°C (104°F). 4. Re-wire.

Replacement Parts List

Ref. No.	Part No.	Description
1	0610-0069	Mounting Screw
2	8793-4008	Inlet Ring
3	0909-0021	Blower Wheel
4	*	Nut, #8-32
5	*	Plain Washer #8
6	0912-0168	Grommet
7	8853-4038	Housing
8	0912-0167	Gasket
9	0905-0154	Outlet Box Cover
10	{ 3M725 Motor (2C915A) 7121-3467 Motor (4C442)	

*Standard hardware item, available locally

LIMITED WARRANTY

Dayton Blowers Models 2C610, 2C915A & 4C442, are warranted by Dayton Electric Mfg. Co. (Dayton) to the original user against defects in workmanship or materials under normal use (rental use excluded), for one year after date of purchase. Any part which is determined to be defective in material or workmanship and returned to an authorized service location, as Dayton designates, shipping costs prepaid, will be repaired or replaced at Dayton's option. For warranty claim procedures, see "Prompt Disposition" below. This warranty gives purchasers specific legal rights and purchasers may also have other rights which vary from state to state.

WARRANTY DISCLAIMER: Dayton has made a diligent effort to illustrate and describe the products in this literature accurately, however, such illustrations and descriptions are for the sole purpose of identification, and do not express or imply a warranty that the products are merchantable or fit for a particular purpose, or that the products will necessarily conform to the illustrations or descriptions.

Except as provided below, no warranty or affirmation of fact, express or implied other than as stated in "LIMITED WARRANTY" above is made or authorized by Dayton, and Dayton liability in all events is limited to the purchase price paid.

Certain aspects of disclaimers are not applicable to consumer products, e.g. (a) some states do not allow the exclusion or limitation of incidental or consequential damages, so the above limitation or exclusion may not apply to you; (b) also, some states do not allow limitations on how long an implied warranty lasts, consequently the above limitation may not apply to you; and (c) by law, during the period of this Limited Warranty, any implied warranties of merchantability or fitness for a particular purpose applicable to consumer products purchased by consumers, may not be excluded or otherwise disclaimed.

PROMPT DISPOSITION: Dayton will make a good faith effort for prompt correction or other adjustment with respect to any product which proves to be defective within warranty. For any product believed to be defective within warranty, first write or call dealer from whom product was purchased. Dealer will give additional directions if unable to resolve satisfactorily, write to Dayton at address below, giving dealer's name, address, date and number of dealer's invoice and describing the nature of the defect. If product was damaged in transit to you, the claim with carrier excluded.

DAYTON ELECTRIC MFG. CO., 5959 W. HOWARD ST.
CHICAGO, ILLINOIS 60648

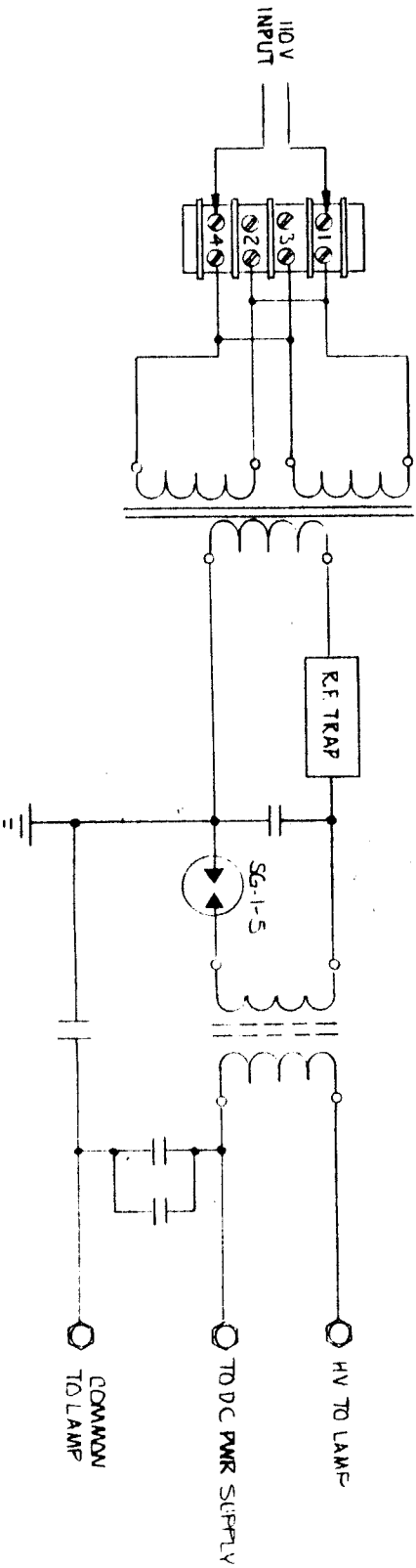

THIS DOCUMENT CONTAINS CONFIDENTIAL INFORMATION OF RENTEC ENGINEERING AND RECEIPT OF THIS INFORMATION DOES NOT GIVE ANY RIGHTS OR PERMISSIONS TO DISCLOSE, REPRODUCE, OR TRANSMIT INFORMATION TO ANY OTHER PERSON OR ENTITY WITHOUT THE WRITTEN CONSENT OF RENTEC ENGINEERING.

REVISIONS		RENTEC ENGINEERING	
NO.	DATE	BY	UPLAND, CA
1			IGNITER SCHEMATIC
2			
3			
4			
5			

TOLERANCES (UNLESS SPECIFIED)	NO.	DATE	BY	SCALE	MATERIAL
DECIMAL	1			1:1	
FRACTIONAL	2				
ANGULAR	3				

DRAWN BY	DATE	DRAWING NO.
CHECKED	11-26-71	E-1000271
TRACED BY	APP'D.	

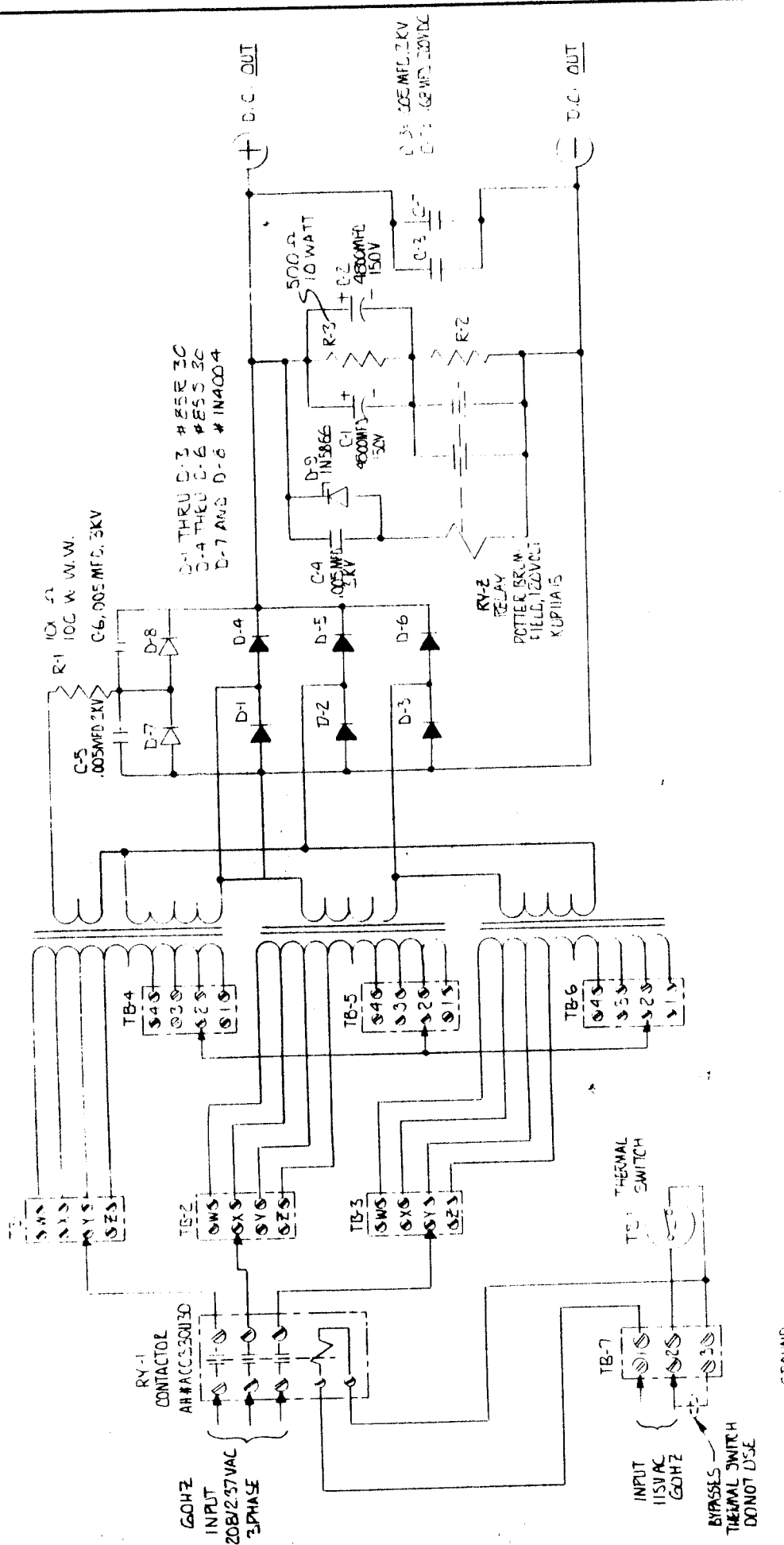

RENTEC ENGINEERING
UPLAND, CA

POWER SUPPLY FOR MTRIC ZELLC WATT

TOLERANCES (EXCEPT AS NOTED)	REVISIONS	NO.	DATE	BY
DECIMAL	1			
FRACTIONAL	2			
ANGULAR	3			
	4			
	5			

DRAWN BY: NONE
DATE: 11-20-68
SCALE: NONE
MATERIAL: DRAWING NO. E-1000-270
TRACED BY: JAG/EL APP'D

THIS DOCUMENT CONTAINS CONFIDENTIAL INFORMATION OF RENTEC ENGINEERING AND RECEIPT OR POSSESSION DOES NOT GIVE ANY RIGHTS TO ANY INFORMATION DISCLOSED HEREIN. ANY RIGHTS TO DISCLOSED INFORMATION ARE RESERVED. WRITTEN CONSENT OF RENTEC ENGINEERING IS REQUIRED.