

# Film-Tech

The information contained in this Adobe Acrobat pdf file is provided at your own risk and good judgment.

These manuals are designed to facilitate the exchange of information related to cinema projection and film handling, with no warranties nor obligations from the authors, for qualified field service engineers.

If you are not a qualified technician, please make no adjustments to anything you may read about in these Adobe manual downloads.

[www.film-tech.com](http://www.film-tech.com)

# CHRISTIE INCORPORATED

## INSTRUCTIONS

FOR

**INSTALLATION AND OPERATION**

OF

**SLC SERIES**

**XENON CONSOLE**

**SLC 20/30/40/45/45R/70**

**TD-641 REV. D**

CHRISTIE INCORPORATED  
10550 Camden Drive  
Cypress, CA 90630  
714-236-8610 Fax: 714-229-3185

**Operator's Manual  
Xenon Console, Model SLC 20/30/40/45/45R/70  
TD641, Rev. D**

Manufactured Under U.S. Patents 3,843,879 and 5,054,909

Other Patents Pending

The information in this document is subject to change without notice and does not represent a commitment on the part of CHRISTIE INCORPORATED (hereinafter referred to as CHRISTIE). CHRISTIE does not assume responsibility for errors that may appear in this document. CHRISTIE or its subsidiaries, designated representatives, and any other vendor of the SLC Xenon Console are not responsible in any way for any liabilities or loss resulting from the use or misuse of this document.

Copyright © 1999 by CHRISTIE INCORPORATED  
All Rights Reserved

All copyrights and trademarks are the property of their respective owners.

**CHRISTIE**  
INCORPORATED  
10550 Camden Drive  
Cypress, CA 90630  
Telephone 714-236-8610  
FAX 714-229-3185

---

---

# TABLE OF CONTENTS

---

<b>TABLE OF CONTENTS</b> .....	<b>i</b>
<b>LIST OF FIGURES AND TABLES</b> .....	<b>iii</b>
<b>1. Introduction</b> .....	<b>1-1</b>
1.1. Contents of the Manual.....	1-1
1.2. Who Should Use This Manual?.....	1-1
1.3. Special Notices .....	1-2
1.3.1. Warning .....	1-2
1.3.2. Caution .....	1-2
1.3.3. Note .....	1-2
<b>2. Safety Precautions</b> .....	<b>2-1</b>
2.1. Wear Protective Clothing .....	2-1
2.2. Allow Lamp to Cool .....	2-2
2.3. Disconnect AC Lines Before Entering Console .....	2-2
2.4. Do Not Look Directly at Lamp.....	2-2
2.5. Avoid Fire Hazards.....	2-3
<b>3. General Description</b> .....	<b>3-1</b>
3.1. The Xenon Lamp .....	3-1
<b>4. Installation Procedures</b> .....	<b>4-1</b>
4.1. Unpacking.....	4-1
4.2. Installation .....	4-1
4.2.1. Leveling Feet .....	4-1
4.2.2. Door Panels .....	4-4
4.2.3. Venting .....	4-4
4.2.4. Mounting the Projector.....	4-5
4.3. Electrical Connections.....	4-5
4.3.1. Verify Voltage .....	4-5
4.3.2. Wiring Hook-Up.....	4-5
<b>5. Alignment and Checkout Procedures</b> .....	<b>5-1</b>
5.1. Mechanical Alignment.....	5-1
5.2. Installation of Xenon Lamp.....	5-1
<b>6. Operating the SLC</b> .....	<b>6-1</b>
6.1. Safety Review .....	6-1
6.2. Starting and Operating the SLC.....	6-1
6.3. Optical Alignment and Adjustment.....	6-4
6.4. Tilt Adjustment.....	6-5
6.5. Replacing the Lamp.....	6-5

6.5.1. Removing the Lamp..... 6-5  
6.5.2. Installing a New Lamp..... 6-5  
6.5.3. Defective Lamps ..... 6-5

**7. Maintenance and Adjustments.....7-1**

---

7.1. Before Opening the Console ..... 7-1  
7.2. Cleaning Optical Surfaces..... 7-1  
    7.2.1. Cleaning Dust..... 7-2  
    7.2.2. Cleaning Grease ..... 7-2  
7.3. Maintaining Other Surfaces..... 7-2  
    7.3.1. Blower ..... 7-3  
    7.3.2. Igniter ..... 7-3  
    7.3.3. Air Flow Interlocks ..... 7-3  
7.4. Aligning Lamphouse Without Alignment Tools..... 7-3  
7.5. Xenon Lamp Autofocus Adjustments (Option ABF)..... 7-4  
    7.5.1. Autofocus Adjustment Procedures..... 7-4  
7.6. Optimizer Reflector..... 7-6  
7.7. Electrical Connections..... 7-6  
7.8. Airflow ..... 7-6  
7.9. Remote Lamp Adjustment Control (Option RBA) ..... 7-6

**8. Troubleshooting .....8-1**

---

8.1. Malfunction: Power Supply Does Not Start..... 8-1  
8.2. Malfunction: Lamp Does Not Ignite ..... 8-2  
8.3. Power Supply Output Is Low Or Not Steady ..... 8-2

**WARRANTY ..... W-1**

**Appendix A: Assembly Diagrams and Parts Lists..... A-1**

---

---

## LIST OF FIGURES AND TABLES

---

Figure 2-1:	Protective Clothing Safety Kit Contents .....	2-1
Figure 4-1:	SLC Xenon Lamp Console (Front View) .....	4-2
Figure 4-2:	SLC Xenon Lamp Console (Rear View) .....	4-3
Figure 4-3:	Minimum and Maximum Exhaust Airflow Requirements for SLC Consoles .....	4-4
Figure 4-4:	Minimum Wire Sizes for AC Connections .....	4-6
Figure 4-5:	Minimum Wire Sizes for DC Connections .....	4-6
Figure 5-1:	Plenum, Top View .....	5-2
Figure 6-1:	Control Panel.....	6-2
Figure 6-2:	Optical Alignment of Xenon Lamp.....	6-4
Table 8-1:	Troubleshooting for Power Supply Does Not Start .....	8-1
Table 8-2:	Troubleshooting for Lamp Does Not Ignite.....	8-2
Table 8-3:	Troubleshooting for Power Supply Output Low or Not Steady .....	8-2
Figure A-1:	Autofocus Assembly .....	A-2
Table A-1:	Parts List for Autofocus Assembly .....	A-3
Figure A-2:	SLC Xenon Lamp Console (Front View) .....	A-4
Table A-2:	Parts List for SLC Xenon Lamp Console (Front View) .....	A-5
Figure A-3:	SLC Xenon Lamp Console (Rear View) .....	A-6
Table A-3:	Parts List for SLC Xenon Lamp Console (Rear View).....	A-7
Figure A-4:	Control Panel.....	A-9
Table A-4:	Parts List for Control Panel.....	A-10
Figure A-5:	Manual Lamp Adjustment Assembly.....	A-11
Table A-5:	Parts List for Manual Lamp Adjustment Assembly.....	A-12
Table A- 6:	Parts List for Plenum, All Models (Top View).....	A-14
Figure A-7:	Power Supply .....	A-15
Table A-7:	Power Supply .....	A-16

## 1. INTRODUCTION

---

### 1.1. CONTENTS OF THE MANUAL

---

This manual contains installation, operation, and operator maintenance procedures for CHRISTIE SLC Xenon Console. The material covered includes:

- General description
- Installation and assembly
- Alignment and checkout procedures
- Operating the SLC
- Troubleshooting.

### 1.2. WHO SHOULD USE THIS MANUAL?

---

This manual provides information suitable for various purposes.

**All users should read Section 2: Safety Precautions.**



**Do not install, operate, maintain, or repair the SLC Xenon Lamp Console unless you have read Section 2, are familiar with the safety precautions, and have followed all warnings and instructions.**

#### **WARNING**

For details on operating the projector and for general information, see:

- *Section 3: General Description*
- *Section 4: Installation Procedures*
- *Section 5: Alignment and Checkout Procedures*
- *Section 6: Operating the SLC.*

Before performing adjustments and periodic maintenance during normal operation, see:

- *Section 4: Installation Procedures*
- *Section 5: Alignment and Checkout Procedures*
- *Section 7: Maintenance and Adjustments*
- *Section 8: Troubleshooting.*

If a problem occurs, see:

- *Section 8: Troubleshooting.*

Additional reference information is contained in the appendices.

### 1.3. SPECIAL NOTICES

---

Three kinds of specific notices are used within this manual to emphasize specific information.

#### 1.3.1. WARNING

---



**WARNING:** Indicates the presence of a hazard that can cause personal injury if the hazard is not avoided.

**WARNING**

#### 1.3.2. CAUTION

---



**CAUTION:** Indicates the presence of a hazard that could cause damage to the system.

#### 1.3.3. NOTE

---

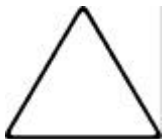

**NOTE:** Provides additional information.



## 2. SAFETY PRECAUTIONS

---

This section highlights the major dangers of working with the SLC Xenon Console. Appropriate safety measures must be taken at all times.

### 2.1. WEAR PROTECTIVE CLOTHING

---



**POSSIBLE EXPLOSION HAZARD!**

**WARNING**

Xenon compact arc lamps are under high pressure. The lamps must be handled with great care. They may explode if dropped or mishandled. Whenever the protective cover is removed from the lamp, authorized protective clothing **must** be worn!

Protective clothing includes, but may not be limited to, rubberized cotton gloves, double-layer 0.040-inch acetate face shield, and quilted ballistic nylon jacket. A Protective Clothing Safety Kit (Part Number 598900-095) is available from CHRISTIE. [Figure 2-1](#) lists the contents of the Safety Kit.



**Wear protective clothing when protective cover is removed from lamp.**

**WARNING**

Instructions from CHRISTIE regarding protective clothing are subject to change. Any local or federal specifications take precedence.

<b>Part Number</b>	<b>Item</b>
598900-092	Safety Jacket
598900-093	Safety Mask
598900-094	Safety Gloves

**Figure 2-1: Protective Clothing Safety Kit Contents**

## 2.2. ALLOW LAMP TO COOL

---



**If the lamp has been in use, wait at least ten minutes after shut-off before opening the lamp housing.**

**WARNING**

The ten-minute waiting period allows the internal lamp pressure to drop to a level at which it is safe to work while wearing the authorized protective clothing. Again, **always** wear protective clothing when the protective cover is removed from the lamp.

## 2.3. DISCONNECT AC LINES BEFORE ENTERING CONSOLE

---



**Pull the AC disconnects in the AC lines before entering the console.**

**WARNING**

Always turn off and disconnect power lines before entering the console. This protects against accidental electrical shock.

## 2.4. DO NOT LOOK DIRECTLY AT LAMP

---



**NEVER LOOK DIRECTLY AT THE LAMP!**

**WARNING**

Serious and permanent eye damage can be caused by the ultraviolet radiation of the lamp. Never attempt to open the console while the lamp is on. Always follow directions for opening console and exposing the Xenon lamp. (See [Section 5.2.](#))

## 2.5. AVOID FIRE HAZARDS

---



**FIRE HAZARD: Keep hands, clothes, and combustible material away from the concentrated light beam in front of the snood.**

**WARNING**

Use extreme caution when working around the SLC Xenon Console. Fire danger may arise from heat, electrical current, or the concentrated light beam emitted by the Xenon lamp.

## 3. GENERAL DESCRIPTION

---

This SLC Xenon Console is a series of projection illuminator systems that combine the rectifier DC power supply and projector base with a Xenon lamphousing into a single, integrated unit with a minimum of installation and wiring expense. These consoles are designed for use with any standard 35-mm or 35/70-mm motion picture projector head.

### 3.1. THE XENON LAMP

---

The SLC Xenon Console utilizes a highly efficient optical system to obtain maximum light output with extreme ease of operation and high reliability. This is accomplished by using a horizontally operated Xenon lamp within a deep, explosion-proof reflector. For maximum efficiency, the reflector has a computer-generated, aspheric shape. The high-voltage igniter (Item 2 in [Figure A-3](#)), required for starting the Xenon lamps, is included within the enclosure.



#### WARNING

**Authorized protective clothing must be worn when protective cover is removed from lamp.**

For lamp description, recommendations, and warranty information, see the CHRISTIE (or equivalent) lamp instructions.

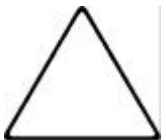

**SLC Consoles are equipped with a double interlock system on the lamp access doors to extinguish the lamp if the enclosure is accidentally opened. Keyed locks are provided on all access doors.**

## 4. INSTALLATION PROCEDURES

---

### 4.1. UNPACKING

---

Follow these instructions if the unit is crated.



CHRISTIE recommends that the unit be moved to the installation site before uncrating.

1. Be sure container is upright.
2. Open crate and remove packing.
3. Carefully remove unit from crate.
4. Thoroughly inspect unpacked unit for damage that may have occurred during shipping.

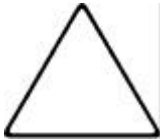

Any damage discovered should be reported to the transportation company at once for inspection and filing of claim.

### 4.2. INSTALLATION

---

Place console in intended operating location in projection booth.

#### 4.2.1. LEVELING FEET

---

Install four (4) leveling feet by screwing one into each of the four corners underneath base until about 1 inch of thread remains exposed. (See Item 8 in [Figure 4-1.](#))



CHRISTIE recommends carefully tilting the console to one side to install the first two feet, then tilting it to the other side to install the other two feet.

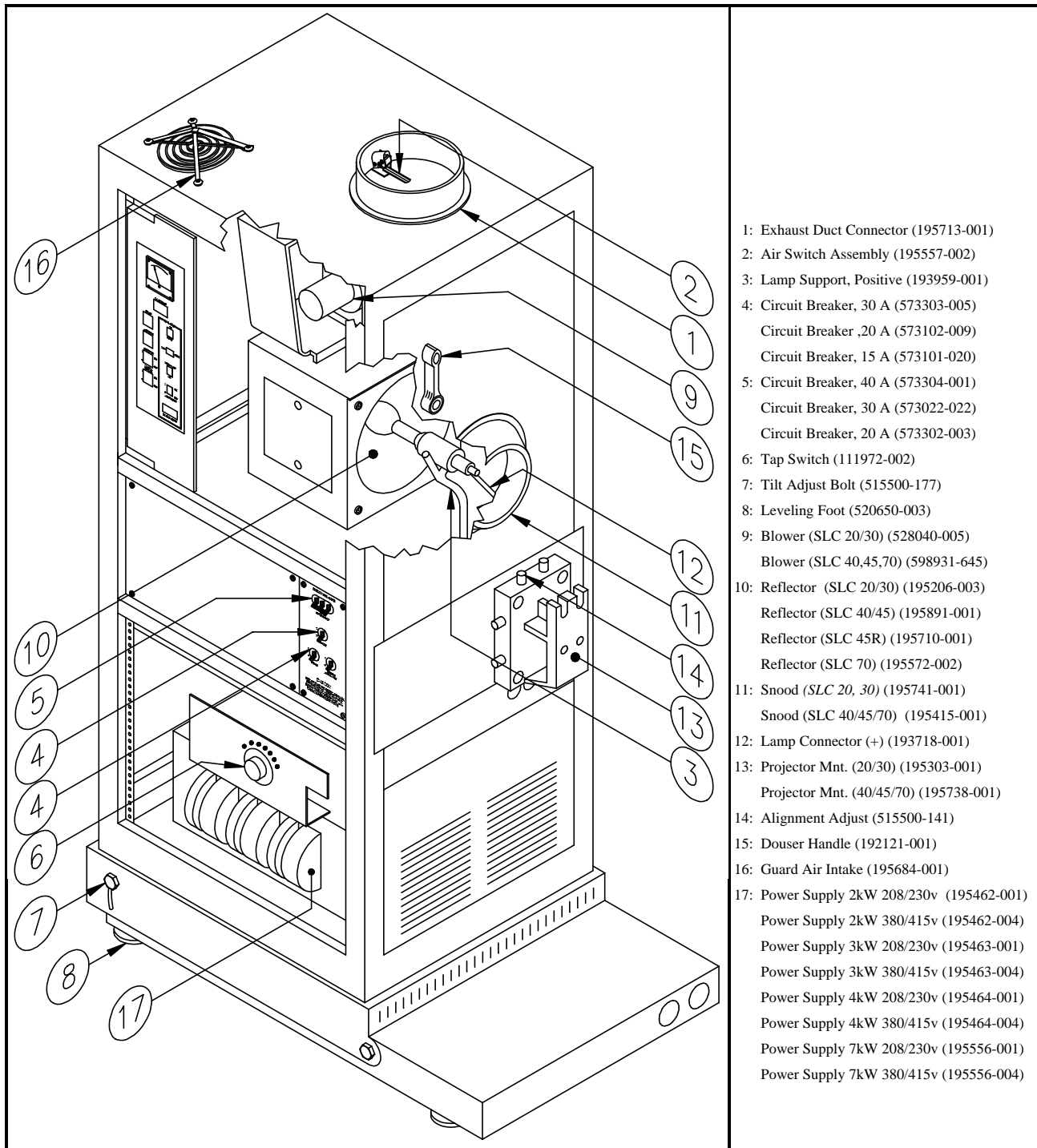
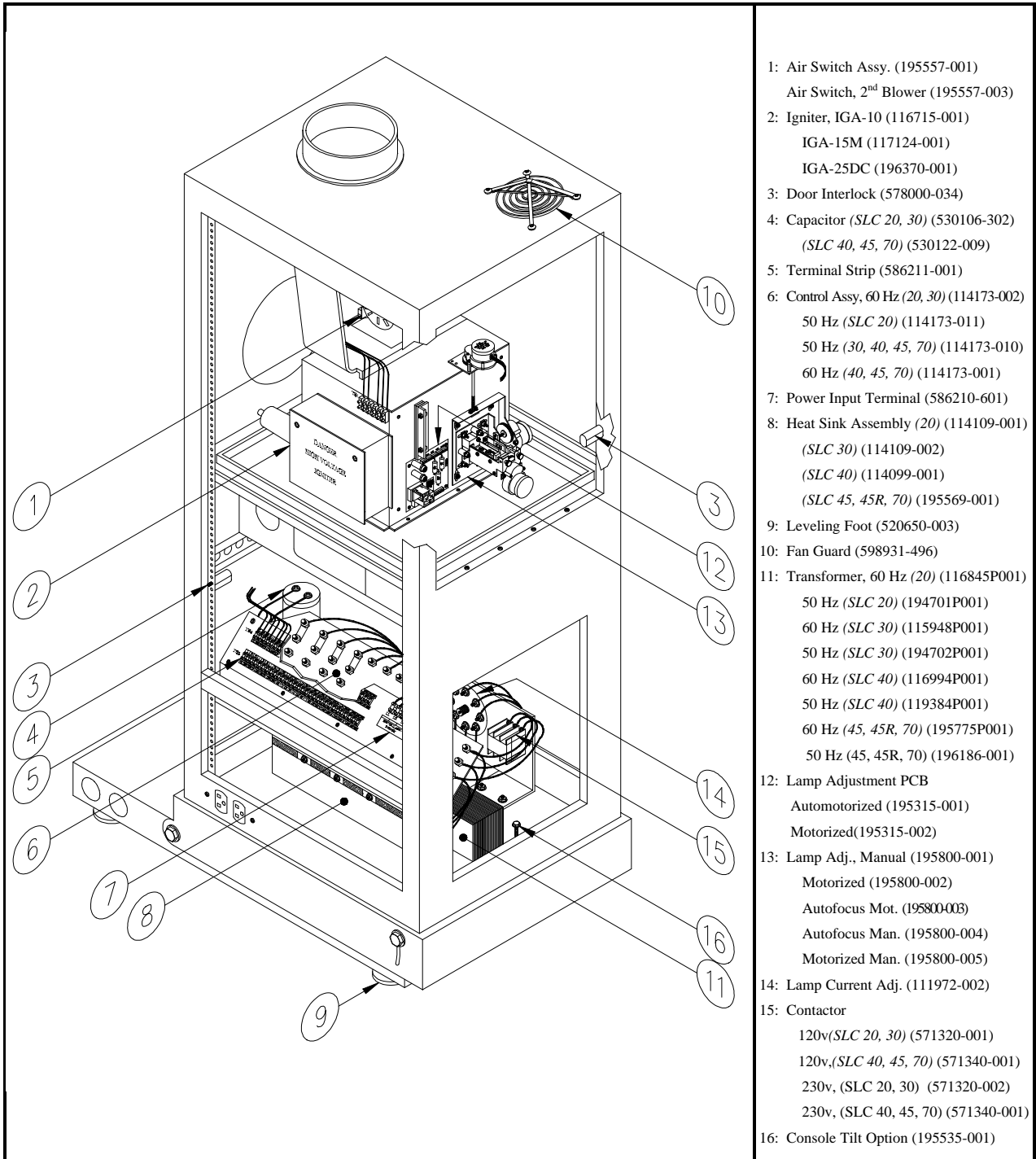

Figure 4-1: SLC Xenon Lamp Console (Front View)



- 1: Air Switch Assy. (195557-001)  
Air Switch, 2<sup>nd</sup> Blower (195557-003)
- 2: Igniter, IGA-10 (116715-001)  
IGA-15M (117124-001)  
IGA-25DC (196370-001)
- 3: Door Interlock (578000-034)
- 4: Capacitor (SLC 20, 30) (530106-302)  
(SLC 40, 45, 70) (530122-009)
- 5: Terminal Strip (586211-001)
- 6: Control Assy, 60 Hz (20, 30) (114173-002)  
50 Hz (SLC 20) (114173-011)  
50 Hz (30, 40, 45, 70) (114173-010)  
60 Hz (40, 45, 70) (114173-001)
- 7: Power Input Terminal (586210-601)
- 8: Heat Sink Assembly (20) (114109-001)  
(SLC 30) (114109-002)  
(SLC 40) (114099-001)  
(SLC 45, 45R, 70) (195569-001)
- 9: Leveling Foot (520650-003)
- 10: Fan Guard (598931-496)
- 11: Transformer, 60 Hz (20) (116845P001)  
50 Hz (SLC 20) (194701P001)  
60 Hz (SLC 30) (115948P001)  
50 Hz (SLC 30) (194702P001)  
60 Hz (SLC 40) (116994P001)  
50 Hz (SLC 40) (119384P001)  
60 Hz (45, 45R, 70) (195775P001)  
50 Hz (45, 45R, 70) (196186-001)
- 12: Lamp Adjustment PCB  
AutomotORIZED (195315-001)  
Motorized (195315-002)
- 13: Lamp Adj., Manual (195800-001)  
Motorized (195800-002)  
Autofocus Mot. (195800-003)  
Autofocus Man. (195800-004)  
Motorized Man. (195800-005)
- 14: Lamp Current Adj. (111972-002)
- 15: Contactor  
120v,(SLC 20, 30) (571320-001)  
120v,(SLC 40, 45, 70) (571340-001)  
230v, (SLC 20, 30) (571320-002)  
230v, (SLC 40, 45, 70) (571340-001)
- 16: Console Tilt Option (195535-001)

Figure 4-2: SLC Xenon Lamp Console (Rear View)

### 4.2.2. DOOR PANELS

All three door panels are removable for easier access to the interior of the console during installation and maintenance.

To remove door panel:

1. Unlock key-lock.
2. Open door.
3. Push down on spring-loaded pin hinge.
4. Remove panel.

To install door panel, reverse the above procedure.

### 4.2.3. VENTING

It is necessary to vent hot exhaust air from console to the outside of the building.

1. Connect a eight-inch inner-diameter, flexible, fireproof ducting material to exhaust duct (Item 1 in [Figure A-2](#)) on top of lamphouse.
2. Ensure that there are no obstructions in ducting, and that air intake openings of console are unobstructed.

If ozone-free lamps are used, a short, vertical exhaust stack may be used, provided local codes do not require the exhaust to be vented directly outside.

Minimum and maximum exhaust airflow requirements for all SLC series models are shown in [Figure 4-3](#).

Model	Minimum Exhaust (ft <sup>3</sup> /min)	Maximum Exhaust (ft <sup>3</sup> /min)
SLC 20	300	400
SLC 30	350	450
SLC 40	450	550
SLC 45, SLC 45R	550	750
SLC 70	750	900

**Figure 4-3: Minimum and Maximum Exhaust Airflow Requirements for SLC Consoles**



#### 4.2.4. MOUNTING THE PROJECTOR

The SLC Console includes a standard projector mounting bracket for CHRISTIE P35 projectors. If any other model projector is to be mounted, contact the CHRISTIE factory.

1. Mount projector on projector mounting bracket (Item 13 in [Figure A-2](#)).
2. Ensure that projector is level and in line with console before tightening mounting bolts.
3. Verify that all four (4) bolts are installed and securely tightened.

#### 4.3. ELECTRICAL CONNECTIONS

SLC Consoles are factory wired and tested. All functions have been carefully tested and calibrated to prevent problems during installation and operation.



**WARNING**

**Before connecting, pull AC disconnect switch in all AC supply lines.**

##### 4.3.1. VERIFY VOLTAGE

Check the AC voltage shown on the console nameplates. Then measure the AC supply voltages with a voltmeter. Verify that the measured voltages do not differ by more than 10% from the rated nominal values of the unit.

##### 4.3.2. WIRING HOOK-UP

1. Pull 3-phase wires and single-phase and ground wires through one of knock-out holes located on front of non-operating side on foot of console. Check charts in [Figure 4-4](#) and [Figure 4-5](#) for correct wire size.



**WARNING**

**Grounding wire (green) must be at least as large in diameter as largest wire used for AC power connections.**

2. Connect 3-phase wires to Terminal Board TB2-L1, TB2-L2, and TB2-L3.
3. Connect single-phase wires to TB2-L1, Neutral, marked 115V single-phase. Connect ground wire to TB2-ground.
4. Check Schematic and/or Automation Manual for wiring hook-up to TB5. These connections are for projector, sound, changeover douser, and auditorium functions.
5. Hook up all wires as required in above instructions.

<b>AC Wiring Hook-Ups</b>					
<b>AC AMPERES</b>	<b>WIRE DIAMETER (AWG) PER CABLE LENGTH</b>				
PER PHASE	50 FT	100 FT	150 FT	200 FT	250 FT
0 - 10	14	14	12	10	10
11 - 15	14	12	10	8	6
16 - 20	12	10	8	8	6
21 - 25	10	10	8	6	4
26 - 35	8	8	6	4	4
36 - 45	6	6	4	4	3
46 - 60	4	4	4	3	1
61 - 70	3	3	3	2	1
71 - 80	2	2	2	1	1/0

**Figure 4-4: Minimum Wire Sizes for AC Connections**

<b>DC Wiring Hook-Ups</b>				
<b>DC AMPERES</b>	<b>WIRE DIAMETER (AWG) PER CABLE LENGTH</b>			
PER PHASE	25 FT	50 FT	75 FT	100 FT
20	10	10	8	6
40	10	8	6	4
60	8	6	4	2
80	4	4	2	1
100	4	3	1	1/0
125	3	1	1/0	2/0
150	3	1	2/0	3/0
200	2	1/0	3/0	4/0

**Figure 4-5: Minimum Wire Sizes for DC Connections**



**All panels must be secured in place, and all doors must be closed and locked, before operating console.**

**WARNING**

---

## 5. ALIGNMENT AND CHECKOUT PROCEDURES

---

### 5.1. MECHANICAL ALIGNMENT

---



When installing an SLC console equipped for 35/70 mm operation, be certain that the optical bench assembly is in the correct sliding position: FORWARD for 70 mm, to the REAR for 35 mm. Contact CHRISTIE for more information or for assistance.

All SLC Consoles are optically aligned at the factory. The optical bench or plenum assembly is aligned with an optical laser alignment tool. At installation, if not already mounted, the projector must subsequently be mechanically aligned to the console snood. This is done by adjusting the jackscrews on the projector mounting bracket (Up/Down, Left/Right). (See Item 14 in [Figure A-2](#).)

A satisfactory mechanical alignment can readily be obtained without the use of any special tools.

### 5.2. INSTALLATION OF XENON LAMP

---



Authorized protective clothing must be worn when protective cover is removed from lamp.

#### WARNING

1. Turn off all AC power.
2. Open top door on the operating (right) side of console.
3. Remove plenum access cover.
4. Verify that lamp model number and rating correspond to the rating on the console nameplate or lamp rating sticker.
5. Remove lamp from package.



Do not touch the quartz body of the lamp with bare hands at any time. Do not apply any bending or twisting force to the quartz body of the lamp.

#### WARNING

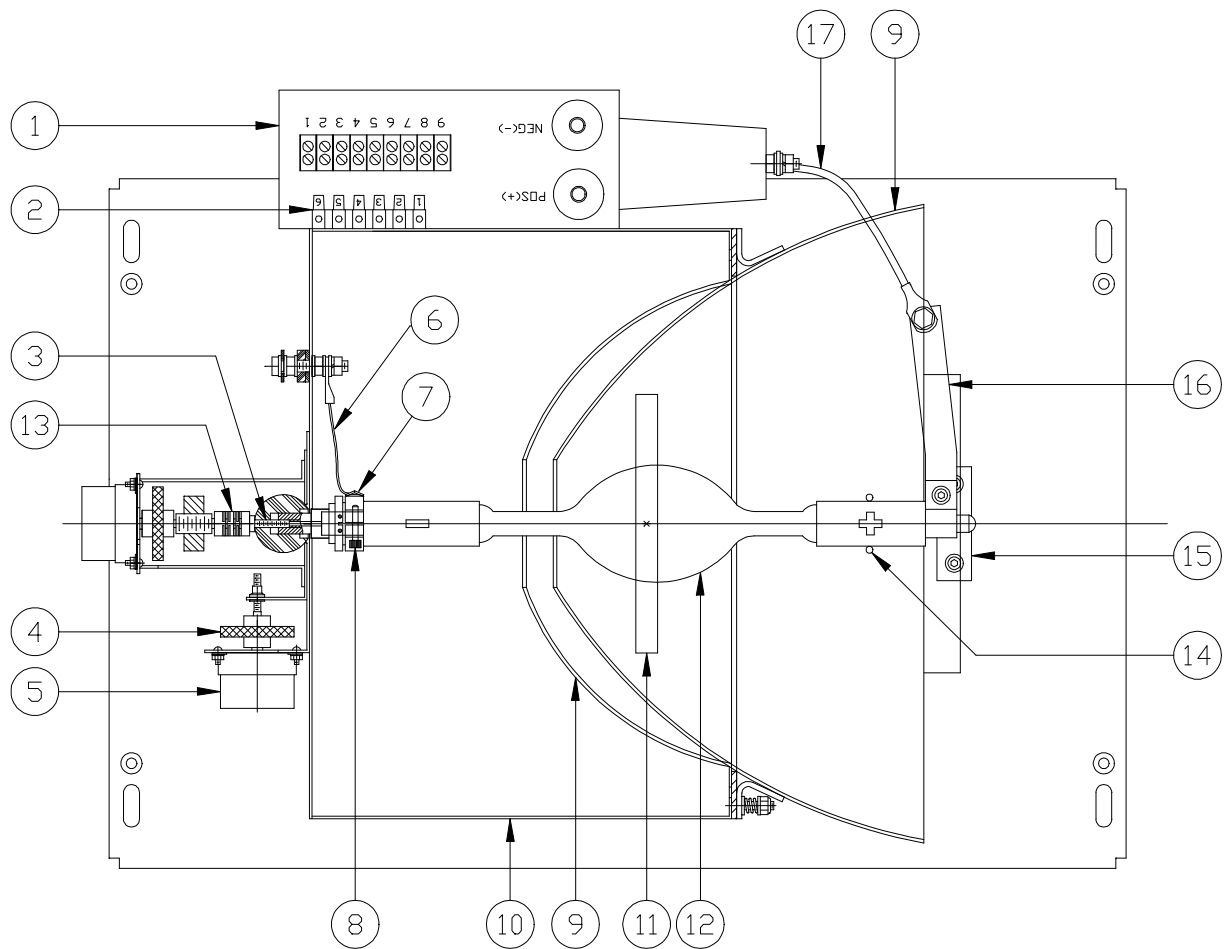

<p>1: Igniter, IGA-10 (116715-001)                      Igniter, IGA-15M (117124-001)                      Igniter, IGA-25DC (196370-001)</p> <p>2: Terminal Board, TB4 (586210-602)</p> <p>3: Focus Screw (195182-001)</p> <p>4: Wheel, Manual Lamp Adjustment (195190-001)</p> <p>5: Motor, Synchronous, Lamp Adjustment, 50 RPM (582000-002)</p> <p>6: Flex Braid Negative Lamp Lead (SLC) (195224-002)</p> <p>7: Negative Lamp Connector (194513-003)</p> <p>8: Allen Screw, #8-32 x 0.75 in L (598931-046)</p> <p>9: Reflector, 2000-3000 W Lamp (SLC 20, 30) (195206-003)                      Reflector, 4500 W (SLC 45R) (195710-001)                      Reflector, 4000 W (SLC 40, 45) (195891-001)                      Reflector, 7000 W (SLC 70) (195572-001)</p> <p>10: Cover Support, Plenum (195171P001)                      Cover Front Support, Plenum (195172P001)</p>	<p>11: Magnet, Arc Stabilizer (515000-092)</p> <p>12: Xenon Lamp, 1600 W Adapter (CXL-16S) *                      Xenon Lamp, 2000 W (CXL-20) *                      Xenon Lamp, 3000 W (CXL-30) *                      Xenon Lamp, 4000 W (CXL-40) *                      Xenon Lamp, 4500 W (CXL-45) *                      Xenon Lamp, 6000 W (CXL-60) *                      Xenon Lamp, 7000 W (CXL-70) *</p> <p>13: Shaft Coupling (195532-001)</p> <p>14: Lamp Support Arm (193959-001)</p> <p>15: Insulator, Forward Lamp Support (193958-002)</p> <p>16: Forward Adapter, Positive Connector (191925-002)</p> <p>17: Lamp Lead, Positive Connector (SLC 20, 30) (193718-001)                      Lamp Lead, Positive Connector (SLC 40) (195446-001)                      Lamp Lead, Positive Connector, (SLC 45, 70) (195446-002)</p> <p>* Specify SLC model when ordering.</p>
---	--

Figure 5-1: Plenum, Top View

6. Remove knurled nut and locking star washer (if present) from negative (cathode) base pin of lamp.
7. Remove protective cover from lamp.
8. Insert threaded cathode end of lamp into negative lamp connector located in rear of plenum. (See Item 7 in [Figure A-6](#).)
9. Screw lamp in place until it bottoms out in lamp connector.
10. Rest positive (anode) end on forward wire cradle.
11. Install positive lamp connector. (See [Figure 5-1](#).)
12. Tighten clamping screws in positive and negative lamp connectors. (See Items 7 and 17, [Figure 5-1](#)).



Proper electrical contact is essential in order to prevent resistance in the positive and negative lamp connectors.

13. Verify that positive lead from lamp to igniter does not touch or run close to any metal parts of lamphouse or mirror.



Leads that are too close to any metal parts will cause arcing during starting pulse, and lamp may not ignite.

14. If quartz body of lamp is accidentally touched with bare hands or becomes dirty, clean quartz body of lamp with alcohol and carefully wipe with soft cloth and distilled water.



**Authorized protective clothing must be worn when cleaning lamp.**

**WARNING**

15. Replace plenum cover plate and close operating door.

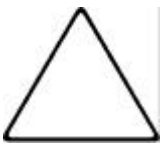

Interlock switches prevent the system from operating if the top door on the operator side and the door on the non-operating side are not closed and locked.

## 6. OPERATING THE SLC

---

### 6.1. SAFETY REVIEW

---



**Do not install, operate, maintain, or repair the SLC Xenon Lamp Console unless you have read Section 2, are familiar with the safety precautions, and have followed all warnings and instructions.**

#### WARNING

- **Never look directly at the Xenon lamp.**  
Serious and permanent eye damage can be caused by the ultraviolet radiation of the lamp. Under no condition should the console be opened except as described in Section 7, below.
- **Do not open the lamp compartment for at least ten minutes after switching the lamp off.**
- **Always wear authorized protective clothing when opening the lamp compartment or handling an unprotected lamp.**
- **Pull the AC disconnects in the AC lines before entering the console.**

### 6.2. STARTING AND OPERATING THE SLC

---

Before starting the lamp, check the rated lamp operating current. The rated lamp operating current is found on the lamp data sheet in the box in which the lamp is shipped.

1. Verify that DC Power ON/OFF Switch (Item 7 in Figure 6-1) is in OFF position.
2. Energize all AC power to console. Pilot lamp (Item 6 in Figure 6-1) will light.



The power supply should not energize until the DC Power ON/OFF Switch is switched ON.

3. Set current adjust on power supply (Item 6 in Figure 4-1) to medium position.
4. Verify that lamphouse cooling is operating. Interlock ready light (Item 5 in Figure 6-1) should be ON, indicating that interlock circuit is closed.

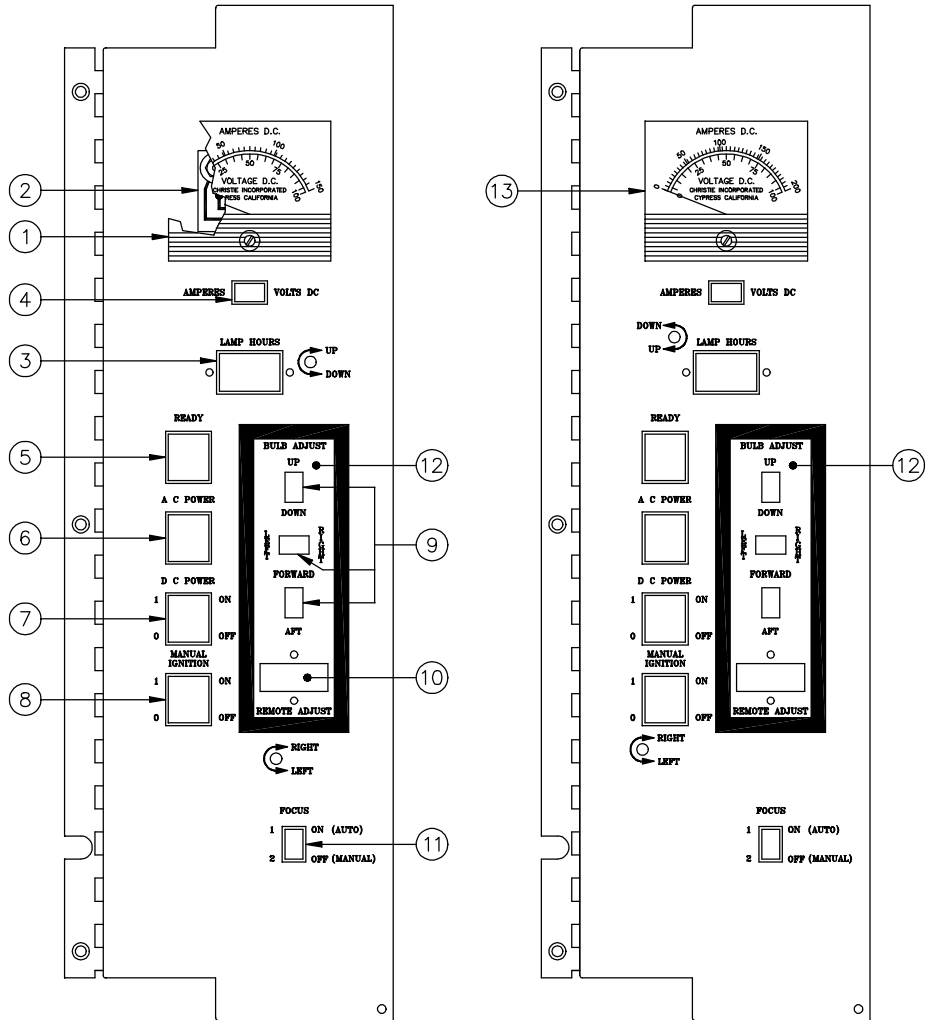

**SLC 20, 30**

**SLC 40, 45, 70**

<p>1: Meter, 150 Amp (535112-321)                  2: Volt/Ampere PCB (195643-0010)                  3: Timer, 120 VAC, 60 Hz (581399-008)                  Timer, ET, 120 VAC, 60 Hz (581399-015)                  Timer, ET, 120 VAC, 50 Hz (581399-016)                  Timer, ET, 240 VAC, 60 Hz (581399-017)                  4: Rocker Switch, SPDT (578712-002)                  5: Indicator, Green, 120 VAC (195138-001)                  Indicator, Green, 250 VAC (546700-054)                  6: Indicator, Amber, 380 VAC (195139-001)                  Indicator, Amber, 440 VAC (195139-002)                  Indicator, Amber, White Base (546700-038)</p>	<p>7: Rocker Switch, DPST, ON/OFF (578900-026)                  8: Rocker Switch, DPST; MOM ON (578900-027)                  9: Rocker Switch, SPDT; MOM (578900-040)                  10: Terminal Receptacle (524310-006)                  11: Rocker Switch, SPDT; ON/ON (578900-042)                  12: Control Panel, Manual (195756-001)                  Control Panel, Motorized, Auto-Focus (195756-002)                  Control Panel, Motorized Manual and                  Auto-Focus Manual (195756-003)                  13: Meter, 200 Amp (535112-317)</p>
--	---

**Figure 6-1: Control Panel**

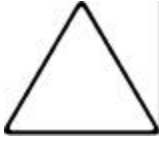

If the light is not on when the pilot lamp (Item 5 in [Figure 6-1](#)) is on, check for an open switch (door switch, blower switch, or exhaust stack switch) in the interlock circuit.

5. If Automation Control is not used, set DC Power ON/OFF switch to ON position.  
If Automation Control (automatic remote control) is used, leave AC ON/OFF switch in OFF position. Lamp operation is controlled by automation relay. If this relay malfunctions, lamp can be ignited by setting DC Power ON/OFF Switch to ON.
6. Verify that douser handle (Item 15 in [Figure 4-1](#)) is closed (in UP position).
7. Turn DC Power ON/OFF Switch to ON position. Lamp will ignite automatically. If lamp does not ignite, momentarily press the Manual Start Button (Item 8 in [Figure A-1](#)) to strike lamp.
8. Check ammeter reading and verify that rated lamp current is not exceeded.



**Do not allow the current to exceed the rated maximum lamp current or drop below 10% of that value.**

**WARNING**

9. If current is too high or too low, use tap switch to adjust power supply to proper current. If, after ten-minute warm-up period, correct current cannot be obtained with tap switch:
  - a) Turn unit off.
  - b) Pull AC disconnect switch.
  - c) Open left side door of console.
  - d) Change Hi-Lo links (see Item 6 in [Figure 2-1](#)) as necessary.



**Turn the DC Power ON/OFF Switch to OFF before rotating the tap switch.**

**WARNING**

10. Extinguish lamp by turning DC Power ON/OFF switch to OFF position.



**Do not service the power supply until it has been turned off for at least two (2) minutes. This allows the capacitors to discharge.**

**WARNING**



### 6.3. OPTICAL ALIGNMENT AND ADJUSTMENT

---

Repeat this procedure every time a lamp is changed. (See illustrations in [Figure 6-2](#).)

1. After lamp has been started and operated as described in [Section 6.2](#), open douser. Observe dark spot projected on screen.
2. Using control panel ([Figure 6-1](#)), adjust lamp focus until dark spot is clearly defined.
3. Center dark spot using vertical and lateral adjustments (Item 9 in [Figure 6-1](#)).
4. Move lamp forward. Light intensity should be equal on both sides of dark spot. If light intensity is not equal on both sides of dark spot, use vertical and/or lateral adjustments to balance light intensity.
5. When light intensity is balanced, move lamp back through FOCUS. Light intensity should again be equal on both sides of dark spot.

If light intensity is not equal on both sides of dark spot, recheck [Section 5.1](#) (Mechanical Alignment) and repeat Steps 1 – 5.

6. Close the douser and replace the projector lens in the projector.
7. Again open the douser and make final lamp adjustments, if necessary, to obtain maximum and uniform light on the screen.

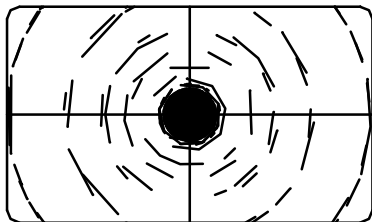

**Correct picture without projector lens installed.**

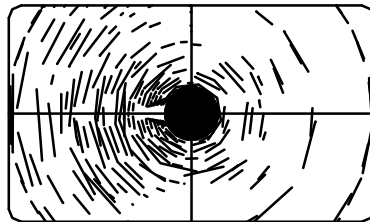

**Lamp centering too far to left; correct with Left/Right lamp adjustment.**

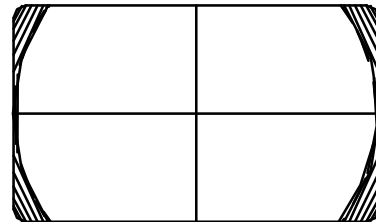

**Correctly centered bright spot with scope lens and aperture plate.**

**Figure 6-2: Optical Alignment of Xenon Lamp**

## 6.4. TILT ADJUSTMENT

The SLC Console is optionally equipped with a jackscrew for easy tilt adjustment. It is located in the bottom rear of the console, and is accessible from either side. (See Item 16 in [Figure 4-2](#).)

1. Loosen all four (4) hold-down bolts. (See Item 7 in [Figure 4-1](#).)
2. Turn jackscrew using 3/4-inch wrench or ratchet. Turn jackscrew clockwise to tilt console downward. Turn jackscrew counterclockwise to tilt console upward.
3. After reaching correct tilt angle, securely tighten all four hold-down bolts.

## 6.5. REPLACING THE LAMP

In accordance with safety precautions, always be certain that the lamp has cooled for at least 10 minutes before replacing it.



**WARNING**

**Authorized protective clothing must be worn when replacing lamp.**

### 6.5.1. REMOVING THE LAMP

CHRISTIE recommends that lamps be replaced before running time exceeds 120% of warranted lifetime. Check running time using elapsed time indicator on control panel (Item 3 in [Figure 6-1](#)).

1. Loosen set screws on positive and negative lamp connectors.
2. Unscrew lamp and remove from reflector. **Immediately** put protective cover on lamp.
3. Record hours that lamp has been used.



Record the elapsed time reading for the old lamp when installing a new lamp.

### 6.5.2. INSTALLING A NEW LAMP

Install the new Xenon lamp according to the directions in Section 5.2.

### 6.5.3. DEFECTIVE LAMPS

Defective lamps under warranty are to be returned to the dealer who provided the lamp in their protective cover and proper packing. They must be returned to CHRISTIE INCORPORATED. The Warranty Claim Forms supplied with the lamp must be filled out

completely. All portions of the failed lamp including electrodes must accompany the lamp to aid CHRISTIE in evaluating the defect.

---

## 7. MAINTENANCE AND ADJUSTMENTS

---



**WARNING**

**Wear protective clothing when protective cover is removed from lamp.**

---

### 7.1. BEFORE OPENING THE CONSOLE

---

Perform these checks at least every 60 days or 500 hours.



**WARNING**

**Pull the AC disconnects in the AC lines before entering the console.**

1. Check contact surfaces of positive (anode) and negative (cathode) connections for cleanliness at regular intervals. Clean electrical contact surfaces as necessary to prevent contact resistance from scorching connectors.
2. Clean air intake openings.
3. Verify that all electrical and lamp connections are tight.

---

### 7.2. CLEANING OPTICAL SURFACES

---



Repeated cleaning of optical surfaces can be more harmful than helpful.  
Clean only when surfaces are excessively dirty.

The exposed optical surfaces of the lamphouse occasionally require cleaning. For optimum system performance, inspect mirror surface for cleanliness every two weeks.



**Always remove the lamp before cleaning the reflector.**

**WARNING**

---

### **7.2.1. CLEANING DUST**

For surfaces that are dusty but do not have smudges, fingerprints, or grease marks:

1. Brush dust from surface with camel-hair brush.
2. Blow remaining dust away with compressed air.

---

### **7.2.2. CLEANING GREASE**

For surfaces that are smudged or have oil or grease smears:

1. Moisten cotton pad with light detergent solution. Pad should be well moistened but not dripping wet.
2. Gently swab exposed lens or mirror surface, using spiral motion and working from center outward toward edge of surface.
3. Sponge up moisture with cheesecloth or lens tissue.



**Always sponge with fresh cheesecloth or lens tissue. Do not wipe with material that has been used before. Throw cheesecloth or lens tissue away after one use.**

4. Dampen cotton pad with methyl alcohol. Wipe surface, using spiral motion from center to edge, in one continuous motion.
5. Dry exposed surface with dry cotton pad or with lens tissue.
6. Repeat procedure above as required.
7. When exposed lens or mirror surface is dry and clean, loosen any remaining lint with brush and blow clean with compressed air.

---

### **7.3. MAINTAINING OTHER SURFACES**

Surfaces other than the optical surfaces require periodic maintenance to keep the lamphouse in good operating condition. These items are:

- Blower
- Igniter
- Air flow interlocks.

These items should be cleaned approximately every six months under normal environmental conditions. Equipment in very dusty or otherwise contaminated areas may require more frequent maintenance.

### **7.3.1. BLOWER**

---

The blower impeller and motor should be cleaned to prevent build-up of contaminant on both the blower impeller surfaces and on the blower motor. Proper operation of the lamp is dependent on providing adequate cooling air flow. A dirty blower may not provide proper air flow, causing the lamp and lamphouse to operate at temperatures that are higher than desirable.

1. Clean loose dirt from blower impeller with vacuum cleaner.
2. Use brush with hot water and suitable detergent to remove dirt that cannot be vacuumed off.



When cleaning the impeller, be careful not to bend the blades or to loosen the balancing weights.

3. Every six months, lubricate blower motor by applying three to four drops of light machine oil to oil holes in motor housing.

### **7.3.2. IGNITER**

---

Periodically clean the high voltage terminal and insulator to prevent accumulation of dust or dirt.

### **7.3.3. AIR FLOW INTERLOCKS**

---

Periodically check and, if necessary, clean the air flow interlock vanes to remove accumulated dirt.

## **7.4. ALIGNING LAMPHOUSE WITHOUT ALIGNMENT TOOLS**

---

1. Inspect reflector and lens and clean if necessary.
2. Inspect lamp for dirt or fingerprints. Clean if required.
3. Center lamp adjustments in rear of lamphouse to midpoint of their range.
4. Install lamp in lamphouse.
5. Use ruler to verify that positive end of lamp is centered in reflector from top to bottom and side to side. If not centered, adjust to center position by adjusting the front lamp support.
6. For best results: With ruler, verify that positive end of lamp is centered left to right in reflector within  $\frac{1}{16}$  in. If not centered, adjust front lamp support to center lamp.



The following adjustments must be made with the rear lamp adjustments centered.

7. When all preliminary adjustments are satisfactory, connect positive connector to anode ferrule. To prevent arcing, keep anode lead clear of any metal parts.
8. With anode centered, firmly tighten anode and cathode clamping screws.
9. Replace plenum cover and doors of lamphouse.
10. Set current control to lowest tap and start lamphouse.
11. Install scope lens and aperture.
12. Put light on screen and adjust lamp focus for maximum light.
13. Move console base sideways and adjust tilt until aperture is centered on screen.
14. Remove projector lens and adjust lamp "left and right." If bright dot does not pass through center of dark shadow, adjust lamp "up and down" until it does. (See [Figure 6-2](#).)
15. Adjust bright dot until it is centered behind dark shadow. (See [Figure 6-2](#).)
16. Replace scope lens.
17. Adjust lamp focus until large bright spot with dark corners appears on screen. (See [Figure 6-2: Optical Alignment of Xenon Lamp](#)). Spot must be centered and four corners must be equal size. If spot is not centered, move projector left or right and up or down, with respect to console, until spot is centered. Do not reposition lamp.
18. Repeat steps 14 through 17 until bright spot fills all four corners at same time lamp focus control is adjusted. Barely fill corners with light and then stop. This is point of maximum light.
19. Adjust current tap switch on rectifier for desired amount of light within current rating of lamp.

## 7.5. XENON LAMP AUTOFOCUS ADJUSTMENTS (OPTION ABF)

The lamp autofocus is designed to give optimum light output in both scope and flat formats. After proper settings have been established, the motorized lamp adjustment automatically readjusts the lamp to its designated position. These adjustments are obtained by setting the two limit switches (Items 15 and 16 in [Figure A-1](#)) to their proper positions.

### 7.5.1. AUTOFOCUS ADJUSTMENT PROCEDURES

1. Connect signal wires.

#### **24 VDC**

Connect two signal wires (Scope/Flat) from automation programmer to TB6-1 and TB6-2. (See Item 25 in [Figure A-1](#).) Set switch S13 to DC mode. Provide 24 VDC pulse (+/-) to activate latching relay for scope/flat format.

**115 VAC**

Connect three signal wires (Scope/Flat) from automation programmer to TB6-1, TB6-2, and TB6-3. (See Item 25 in [Figure A-1](#).) Set switch S13 to AC mode. Provide 115 VAC to TB6-1 or TB6-4 to activate latching relay for scope/flat format.

2. Turn autofocus switch (Item 11 in [Figure 6-1](#)) to ON (1).
3. Activate automation programmer for flat position. Observe that lamp focus adjustment moves lamp forward. If the lamp adjustment moves in reverse:

**24 VDC**

Exchange the position of the two wires.

**115 VAC**

Exchange the position of the two wires of TB6-1 and TB6-3.

After correct travel has been obtained, proceed to next step.

4. Turn Autofocus switch to OFF (0).
5. Obtain desired light level on screen for flat format by adjusting up/down, left/right, and forward/aft switches (Items 9 in [Figure 6-1](#)).
6. Adjust flat adjustment thumbscrew (Item 18A in [Figure A-1](#)): If green light (Item 26 in [Figure A-1](#)) is ON, turn thumbscrew counterclockwise until light goes out. If green light is not ON, turn thumbscrew clockwise until green light comes ON. Turn thumbscrew back and forth several times to determine exact position where green light turns ON. This position is correct setting for flat format.
7. Activate automation for scope format. Set desired light level on screen for scope format by adjusting up/down, left/right, and forward/aft switches (Items 9 in [Figure 6-1](#)).
8. Adjust scope adjustment thumbscrew (Item 18B in [Figure A-1](#)): If red light (Item 27 in [Figure A-1](#)) is ON, turn thumbscrew clockwise until light goes out. If red light is not ON, turn thumbscrew counterclockwise until red light comes on. Turn thumbscrew back and forth several times to determine exact position where red light turns ON. This position is correct setting for scope format.
9. Turn autofocus switch to ON (1).
10. Activate automation several times between scope and flat formats to verify that autofocus adjustment moves to scope and flat settings as required.
11. Verify that light levels on screen stay at maximum or desired level for both scope and flat formats.



The lamp autofocus operates only when the autofocus switch is in the ON position. Manual lamp adjustment is possible only when the autofocus switch is in the OFF position. All autofocus adjustments must be made with the autofocus switch in the OFF position. The red and green lights do not light when the Autofocus switch is in the ON position.



## 7.6. OPTIMIZER REFLECTOR

---

The SLC OPTIMIZER reflector is designed to give maximum performance (light output) when the Xenon lamp has reached the optimum operating temperature for arc size and stability (two to three minutes). Ensure that the DC current setting to the lamp is correct and the lamp temperature has stabilized before making final autofocus adjustment.



**Do not allow the current to exceed the rated maximum lamp current or drop below 10% of that value.**

**WARNING**

## 7.7. ELECTRICAL CONNECTIONS

---

It is very important that all electrical connections are mechanically secure or tight. The DC connections are especially important due to their relatively high current and low voltage. A loose lamp connection causes overheating of the lamp and premature failure. A periodic inspection should be made regularly, at least every 60 days.

## 7.8. AIRFLOW

---

Proper airflow for cooling the Xenon lamp is very important to sustain lamp life. Clean blower wheels and oil blower motors at least every six months as described in [Section 7.3.1](#). Be careful not to disturb or remove the balance weights on the blower wheel while cleaning.

## 7.9. REMOTE LAMP ADJUSTMENT CONTROL (OPTION RBA)

---

The remote lamp adjustment control unit is equipped with a six-foot umbilical cord. This cord enables the operator to stand at the viewport while operating the lamp adjustments to attain maximum screen illumination. The RBA is a plug-in unit, and can be moved between SLC lamphouses.

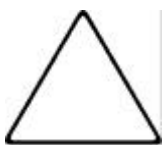

The lamp autofocus switch must be in the OFF position to operate the remote lamp adjustment unit.

## 8. TROUBLESHOOTING

This section helps the user to identify and, where possible, correct system malfunctions in SLC Xenon Consoles. The sections below are organized by malfunction type. For each malfunction, the manual lists symptoms associated with possible problems, and then presents a table containing probable causes and steps to be taken to correct the problem.

Christie suggests that, when following these troubleshooting procedures to correct a problem, users:

1. Copy the appropriate tables
2. Record observations in the rightmost column
3. Include annotated copies with maintenance and repair records for future reference.

### 8.1. MALFUNCTION: POWER SUPPLY DOES NOT START

The system does not power up.

	Probable Cause	Corrective Action	Date/Remarks
A	No AC (3-phase) voltage at TB2.	Check disconnect switch or circuit breaker at AC distribution panel.	
B	Phase voltages are not equal at TB2.	Measure TB2-L1, L2, and L3 for missing or low voltage; correct loose or damaged wire.	
C	Ready lamp is not on, interlock or blower switches not functioning.	Check that all switches are closing properly. Continuity each switch if necessary.	

**Table 8-1: Troubleshooting for Power Supply Does Not Start**

## 8.2. MALFUNCTION: LAMP DOES NOT IGNITE

The system powers up, but the lamp does not ignite.

	Probable Cause	Corrective Action	Date/Remarks
A	Ready lamp is not on.	Check all interlock or blower switch circuits.	
B	DC supply is not set to proper value.	Increase lamp current by adjusting power supply tap switch.	
C	Failed power supply.	With DC power switch ON (open circuit), measure across igniter (+) and (-) positions for 85VDC minimum. If minimum voltage is not present, check power supply output.	
D	Failed igniter	Listen for igniter buzz when manual start button is pushed. If buzz is heard, replace spark gap or AC transformer in igniter.	
E	Igniter relay has failed.	Listen for relay to pull in as start button is pushed. If relay does not activate, measure coil voltage and/or check relay circuit. If no output voltage, replace defective relay.	
F	Lamp failed.	Inspect lamp and replace.	

**Table 8-2: Troubleshooting for Lamp Does Not Ignite**

## 8.3. POWER SUPPLY OUTPUT IS LOW OR NOT STEADY

Power is erratic.

	Probable Cause	Corrective Action	Date/Remarks
A	One phase open or low at TB2 or TB1	Inspect all DC and AC connections. Measure voltages at TB2-L1, TB2-L2, and TB2-L3, then at TB1-HI/LO links. Check AC source or repair circuit.	
B	Failed diode	With power supply OFF, check for open or short in diodes. Use ohmmeter and reverse leads. If both measurements are below 1 $\Omega$ , diode is shorted. If above 10 k $\Omega$ , diode is open. Replace diode.	

**Table 8-3: Troubleshooting for Power Supply Output Low or Not Steady**

---

---

# WARRANTY

---

---

## COVERING THEATRE PRODUCTS MANUFACTURED BY

# CHRISTIE INCORPORATED

(herein referred to as "CHRISTIE")

CHRISTIE warrants the apparatus sold to the extent of the parts necessary to correct any defect in workmanship or materials which may develop under proper or normal use for a period of one (1) full year (*90 days on electric motors*) from date of installation (*except as noted below*), but not to exceed eighteen (18) months from date of shipment from CHRISTIE INCORPORATED. CHRISTIE reserves the right to have the apparatus returned, freight prepaid, to the CHRISTIE factory to effect the warranty repairs.

Replacement parts for warranty repairs will be shipped promptly by CHRISTIE, FOB factory, and invoiced to the customer. Credit will be issued upon return of the defective part or parts, prepaid, to the CHRISTIE factory.

The above shall constitute a fulfillment of all CHRISTIE liabilities in respect to said apparatus.

This warranty does not cover the following items:

Special customer specified purchased parts or materials; also, Xenon, mercury, and other types of lamps (*lamps*).

CHRISTIE shall not be liable for any consequential damages except:

CHRISTIE will replace standard CHRISTIE reflector under warranty in lamphouse damaged by failure of CHRISTIE Xenon lamp during its warranted life and if properly operated, under the following terms and conditions:

- A. If the original reflector installed is *less than one year old*, *full credit* will be issued.
- B. If the original reflector is *more than two years, but less than three years old*, *one-quarter credit* will be issued.
- C. After *three years* from date of original installation, *no credit* will be issued.



---

---

# Appendix A

---

---

## Appendix A: Assembly Diagrams and Parts Lists

---

Appendix A contains diagrams and parts lists for these major components of the SLC Xenon Lamp Console:

1. [Autofocus Adjustment Assembly](#)
2. [SLC Console \(Front View\)](#)
3. [SLC Console \(Rear View\)](#)
4. [Control Panel](#)
5. [Manual Lamp Adjustment Assembly](#)
6. [Plenum \(Top View\)](#)
7. [Power Supply](#).

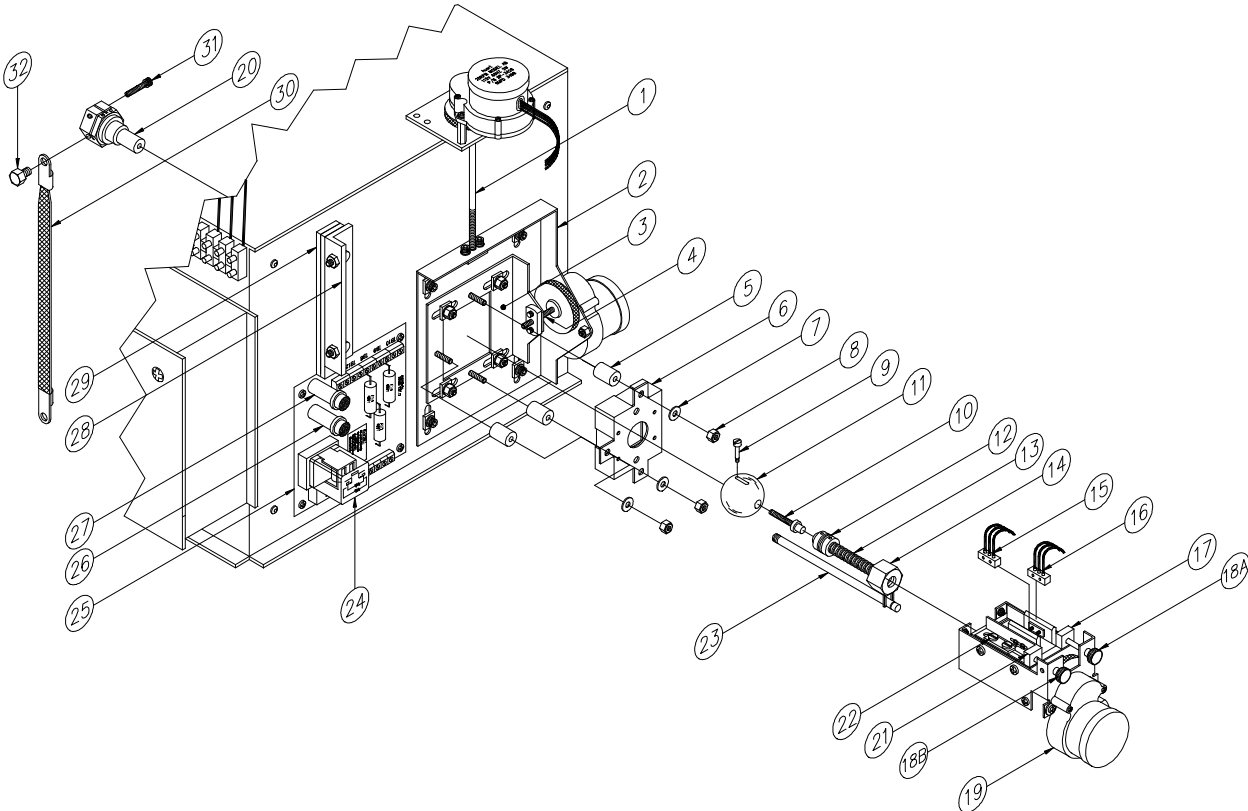

Figure A-1: Autofocus Assembly

#	Description	Part Number
1	Lamp Adjustment Screw, Long	195145-001
2	Plate, Vertical Adjustment	195758P001
3	Plate, Horizontal Adjustment	195753P001
4	Lamp Adjustment Screw, Short	195145-002
5	Spacer, 0.171 in ID x 0.4375 in OD	598931-825
6	Box, Horizontal Adjustment	195752P001
7	Washer, Flat, #8	515819-303
8	ESNA Nut, 8-32, Nylon Steel	--
9	Screw, Shoulder 4-40 x 0.5 in L	598931-619
10	Adjustment Screw, Lamp Rear Adjustment	195182-001
11	Pivot Ball	194512-002
12	Helical Coupling, 6.0 mm ID	195532-001
13	Screw-Switch, Adjustment	195331-001
14	Nut-Switch, Adjustment	195329-001
15	Switch, Limit Assembly	195325-001
16	Switch, Limit Assembly	195325-002
17	Switch Mounting Plate, Right	195759-001
18	Switch Adjustment Screw, 8-32 x 2.0 in L	--
	Switch Adjustment Knob	598931-526
19	Motor, Synchronous Reversible	582000-002
20	Rear Adapter Lamp	194513-003
21	Switch Mounting Plate, Left	195579-002
22	Screw, Shoulder, Slotted	195346-001
23	Pivot Switch Adjustment	195298-001
24	Relay, Magnetic Latch, 120 VAC, 10 Amp	571210-003
	Relay, Magnetic Latch, 24 VDC, 10 Amp	571210-004
25	PCB Assembly, Lamp Adjustment	195315-001
	PCB Assembly, Lamp Adjustment	195315-002
26	Indicator Lamp, Green	546700-034
27	Indicator Lamp, Red	546700-025
28	Shunt, 200 Amp ( <i>SLC 45R, 70</i> )	111786-001
	Shunt, 150 Amp ( <i>SLC 20, 30, 40</i> )	113460-001
29	Insulator, Shunt; 0.1875 in Thk	195243-001
	Insulator, Shunt; 0.125 in Thk	195243-002
30	Flex Braid Negative Lamp Lead ( <i>CXC</i> )	195224-001
31	Screw, Socket Head Cap, 10-32 x 0.625 in L	598931-049
32	Screw, Hex Head, 1/4-20 x 0.375 in, Steel	--

**Table A-1: Parts List for Autofocus Assembly**



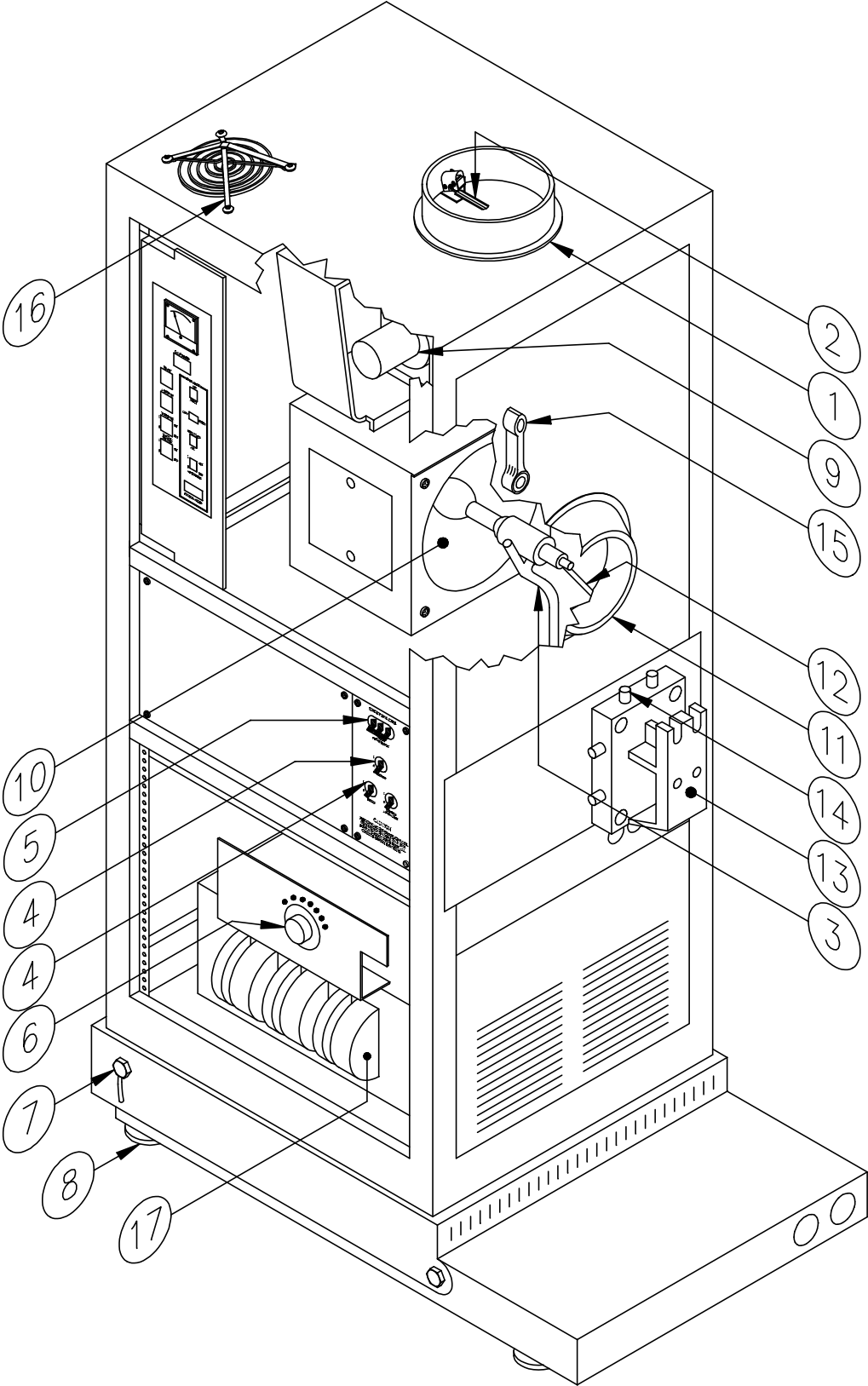

Figure A-2: SLC Xenon Lamp Console (Front View)

#	Description	Part Number
1	Exhaust Duct Connector, 8.0 in	195713-001
2	Air Switch 1000 Assembly	195557-002
3	Lamp Support Arm, Positive	193959-001
4	Circuit Breaker, 1-Pole, 30 Amp	573022-022
	Circuit Breaker, 1-Pole, 20 Amp	573102-009
	Circuit Breaker, 1-Pole, 15 Amp	573101-020
5	Circuit Breaker, 3-Pole, 20 Amp	573302-003
	Circuit Breaker, 3-Pole, 30 Amp	573303-005
	Circuit Breaker, 3-Pole, 40 Amp	573304-001
6	Tap Switch Assembly, Lamp Current Adjustment	111972-002
7	Tilt Adjustment Lock Bolt (2)	515500-177
8	Leveling Foot (4)	520650-003
9	Blower (SLC 20, 30)	528040-005
	Blower (SLC 40,45, 70)	598931-645
10	Reflector, 2000 - 3000 W	195206-003
	Reflector, 4000, 4500 W	195891-001
	Reflector, 4500 W (Reference)	195710-001
	Reflector, 7000 W	195572-002
11	Snood (SLC 20, 30)	195741-001
	Snood (SLC 40,45,70))	195415-001
12	Positive Lamp Connector	193718-001
13	Projector Bracket (SLC 20, 30)	195303-001
	Projector Bracket (SLC 40, 45, 70)	195738-001
14	Projector Alignment Adjustment Screw	515500-141
15	Douser Handle	192121-001
16	Guard Air Intake	195684-001
17	Power Supply CCX20-02, 208/230 VAC, 60 Hz	195462-001
	Power Supply CCX20-34Z, 380/415 VAC, 50 Hz	195462-004
	Power Supply CCX30-02, 208/230 VAC, 60 Hz	195463-001
	Power Supply CCX30-34Z, 380/415 VAC, 50 Hz	195463-004
	Power Supply CCX40-02, 208/230 VAC, 60 Hz	195464-001
	Power Supply CCX40-34Z, 380/415 VAC, 50 Hz	195464-004
	Power Supply CCX70-02, 208/230 VAC, 60 Hz	195556-001
	Power Supply CCX70-34Z, 380/415 VAC, 50 Hz	195556-004

**Table A-2: Parts List for SLC Xenon Lamp Console (Front View)**

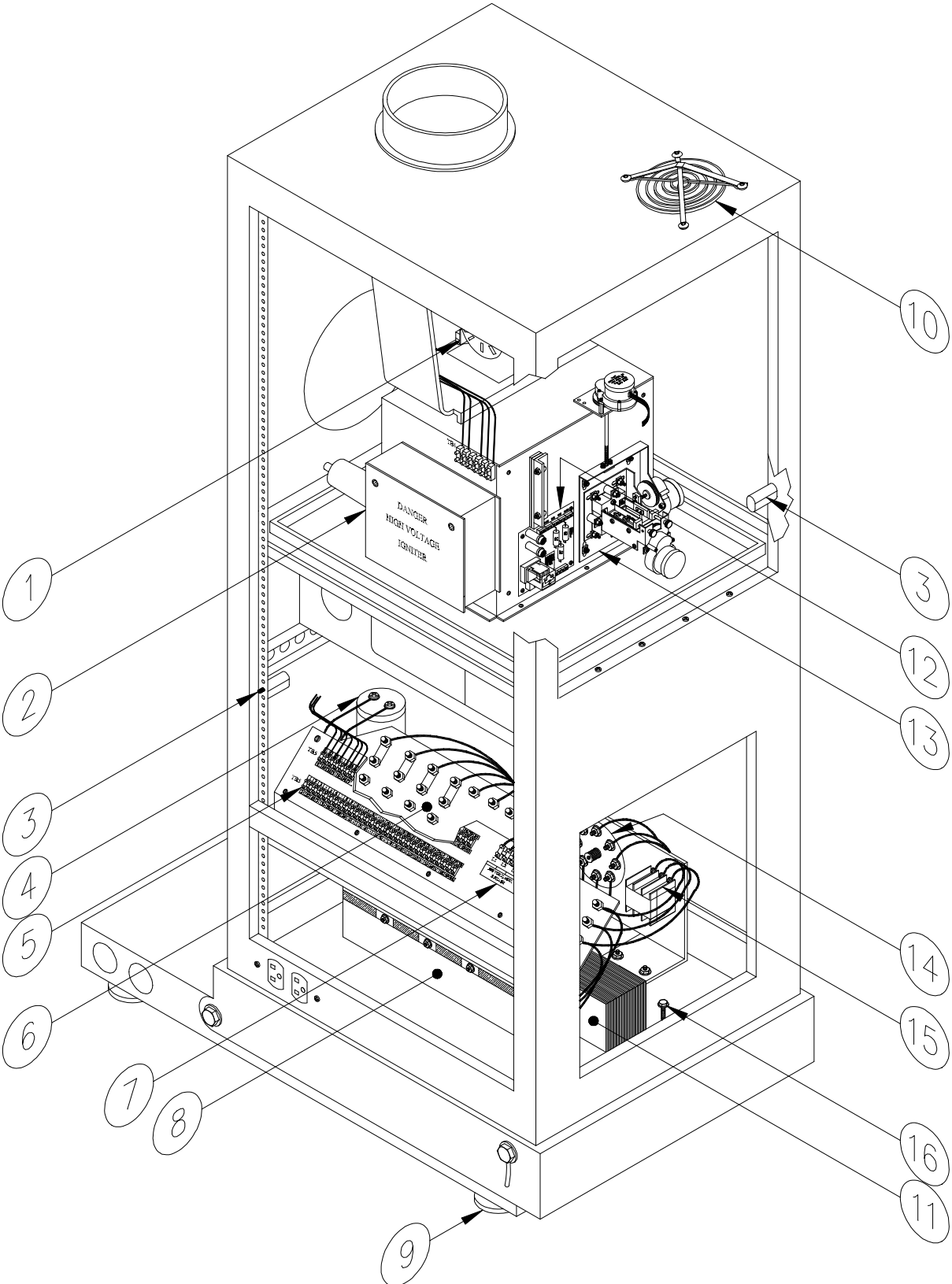
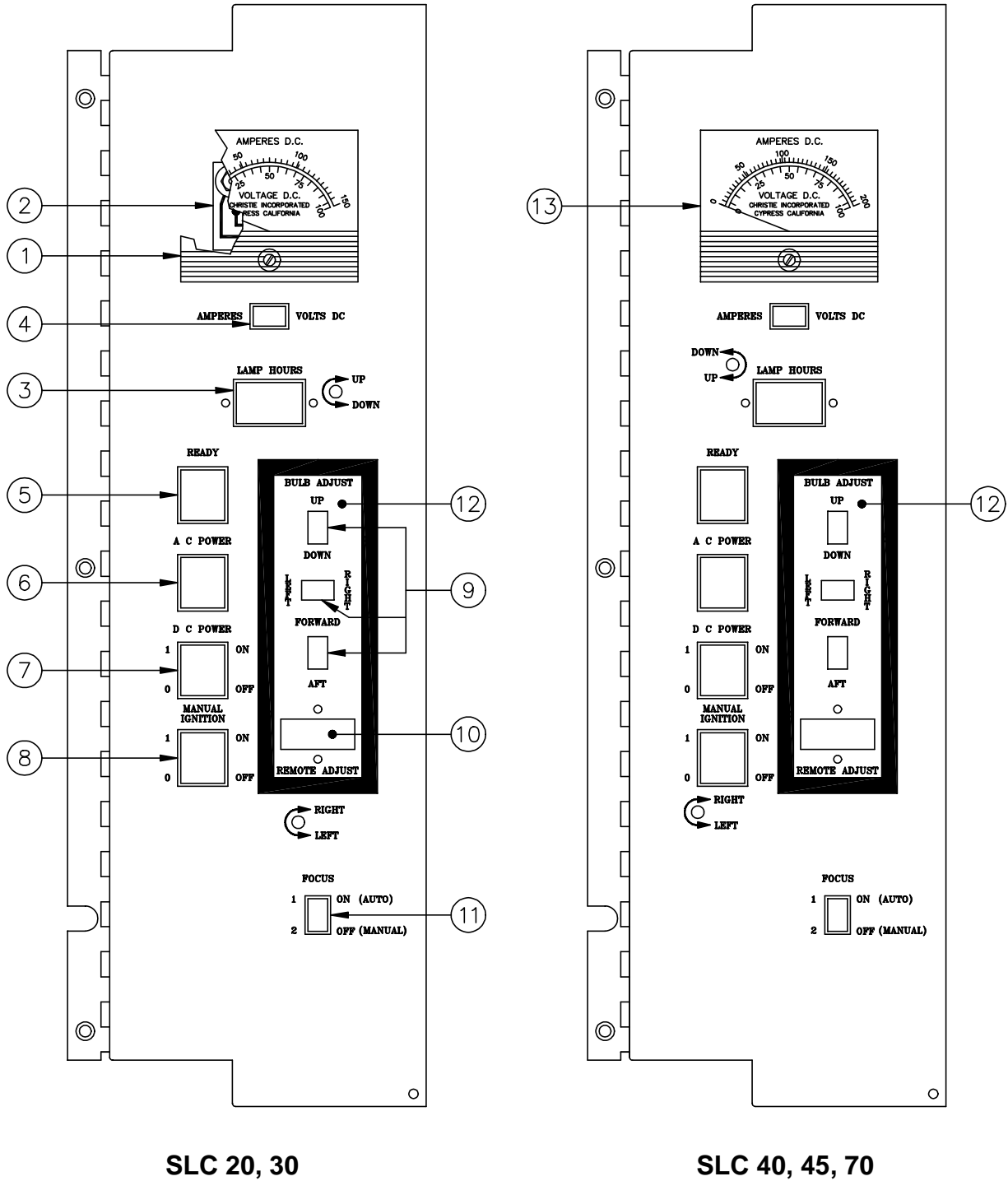

Figure A-3: SLC Xenon Lamp Console (Rear View)

#	Description	Part Number
1	Air Switch 1600 Assembly	195557-001
	Air Switch 1600 Assembly, Second Blower	195557-003
2	Igniter, IGA-10	116715-001
	Igniter, IGA-15M	117124-001
	Igniter, IGA-25DC	196370-001
3	Door Interlock Switch	578000-034
4	Capacitor (SLC 20, 30)	530106-302
	Capacitor (SLC 40, 45, 70)	530122-009
5	Terminal Strip, with Wire Guard	586211-001
6	Control Assembly, 60 Hz (SLC 20, 30)	114173-002
	Control Assembly, 50 Hz (SLC 20)	114173-011
	Control Assembly, 50 Hz (SLC 30, 40, 45, 70)	114173-010
	Control Assembly, 60 Hz (SLC 40, 45, 70)	114173-001
7	Power Input Terminal, 55 Amp	586210-601
8	Heat Sink Assembly (SLC 20)	114109-001
	Heat Sink Assembly (SLC 30)	114109-002
	Heat Sink Assembly (SLC 40)	114099-001
	Heat Sink Assembly (SLC 45, 45R, 70)	195569-001
9	Leveling Foot (4)	520650-003
10	Fan Guard, 4.5 x 0.200/0.600 in DP	598931-496
11	Transformer, 208/230 VAC, 60 Hz (SLC 20)	116845P001
	Transformer, 380/415VAC, 50 Hz (SLC 20)	194701P001
	Transformer, 208/230 VAC, 60 Hz (SLC 30)	115948P001
	Transformer, 308/415VAC, 50 Hz (SLC 30)	194702P001
	Transformer, 208/230 VAC, 60 Hz (SLC 40)	116994P001
	Transformer, 380/415VAC, 50 Hz (SLC 40)	119384P001
	Transformer, 208/230VAC, 60 Hz (SLC 45, 45R, 70)	195775P001
	Transformer, 380/415, 50 Hz (SLC 45, 45R, 70)	196186-001
12	PCB Assembly, Lamp Adjustment	195315-001
	PCB Assembly, Lamp Adjustment	195315-002
13	Xenon Lamp Adjustment, Manual	195800-001
	Xenon Lamp Adjustment, Motorized	195800-002
	Xenon Lamp Adjustment, Auto-Focus, Motorized	195800-003
	Xenon Lamp Adjustment, Auto-Focus, Manual	195800-004
	Xenon Lamp Adjustment, Motorized, Manual	195800-005
14	Tap Switch Assembly, Lamp Current Adjustment	111972-002
15	Contactora, Relay (SLC 20, 30), 120V	571320-001
	Contactora, Relay (SLC 40, 45, 70), 120V	571340-004
	Contactora, Relay (SLC 20, 30), 230V	571320-002
	Contactora, Relay (SLC 40, 45, 70), 230V	571340-001
16	Console Tilt Option	195535-001

**Table A-3: Parts List for SLC Xenon Lamp Console (Rear View)**



SLC 20, 30

SLC 40, 45, 70

Figure A-4: Control Panel

#	Description	Part Number
1	Meter, 150 Amp, 100 VAC	535112-321
2	Volt/Ampere PCB, Assembly	195643-001
3	Timer-Elect, 100 Khr, 120 VAC, 60 Hz	581399-008
	Timer-Elect, 100 Khr, ET, 120 VAC, 60 Hz	581399-015
	Timer, Electric, 100 Khr, ET, 120 VAC, 50 Hz	581399-016
	Timer, Electric, 100 Khr, ET, 240 VAC, 60 Hz	581399-017
4	Switch, Rocker, SPDT, ON/MOM ON	578712-002
5	Indicator, Green Lens, Modified, 120 VAC	195138-001
	Indicator, Green Lens, 250 VAC	546700-054
6	Indicator, Amber Lens, Modified, 380 VAC	195139-001
	Indicator, Amber Lens, Modified, 440 VAC	195139-002
	Indicator, Amber Lens, White Base	546700-038
7	Switch, Rocker, DPST ON/OFF, 125 VAC, 10 Amp	578900-026
8	Switch, Rocker, DPST; MOM ON, 25 VAC, 10 Amp	578900-027
9	Switch, Rocker, SPDT; MOM, Center OFF	578900-040
10	Terminal Receptacle, with Angle Brackets	524310-006
11	Switch, Rocker, SPDT; ON/ON, 120 VAC, 5 Amp	578900-042
12	Control Panel, Manual	195756-001
	Control Panel, Motorized, Auto-Focus	195756-002
	Control Panel, Motorized Manual and Auto-Focus Manual	195756-003
13	Meter, 200 Amp, 100 VAC	535112-317

**Table A-4: Parts List for Control Panel**

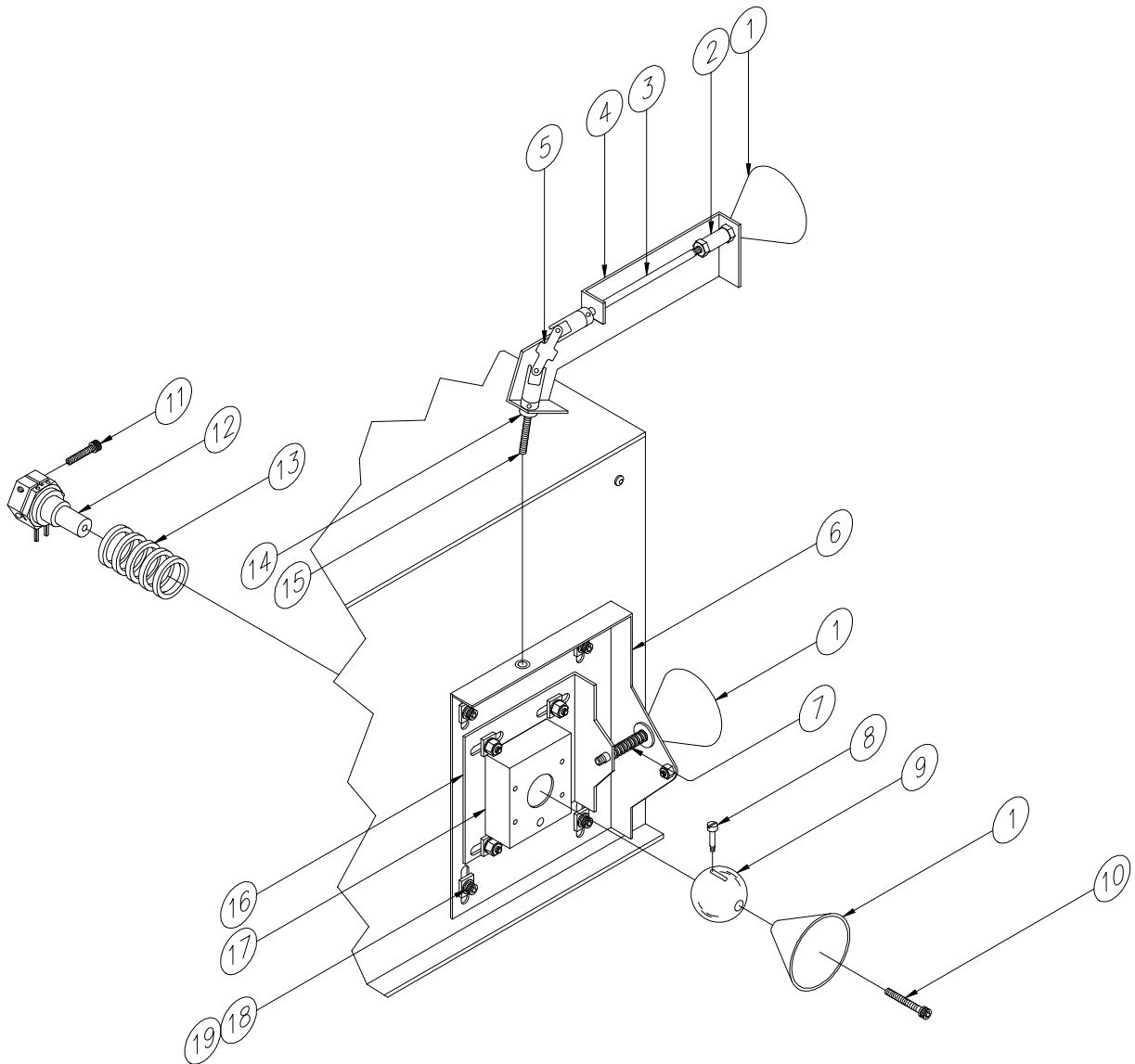

**Figure A-5: Manual Lamp Adjustment Assembly**

<b>#</b>	<b>Description</b>	<b>Part Number</b>
1	Adjustment Guide	193571-001
2	Standoff, Female	598931-523
3	Lamp Adjustment Screw, 4.85 in L	195145-003
4	Bracket Vertical Adjustment	195499-001
5	Universal Joint	598931-554
6	Plate, Vertical Adjustment	195758P001
7	Compression Spring	515610-046
8	Screw, Shoulder, 4-40 x 0.5 in L	598931-619
9	Pivot Ball	194512-002
10	Screw, Socket Head Cap, #8-32 x 1.25 in L	--
11	Screw, Socket Head Cap, 10-32 x 0.625 in L	598931-049
12	Rear Adapter, Lamp	194513-003
13	Compression Spring, Coil	515610-047
14	Collar, Metal	598931-553
15	Lamp Adjustment Screw, 1.73 in L	195145-004
16	Horizontal Adjustment Plate	195753P001
17	Box Horizontal Adjustment	195752P001
18	Shoulder Washer	515000-002
19	Spring Washer	515801-202

**Table A-5: Parts List for Manual Lamp Adjustment Assembly**



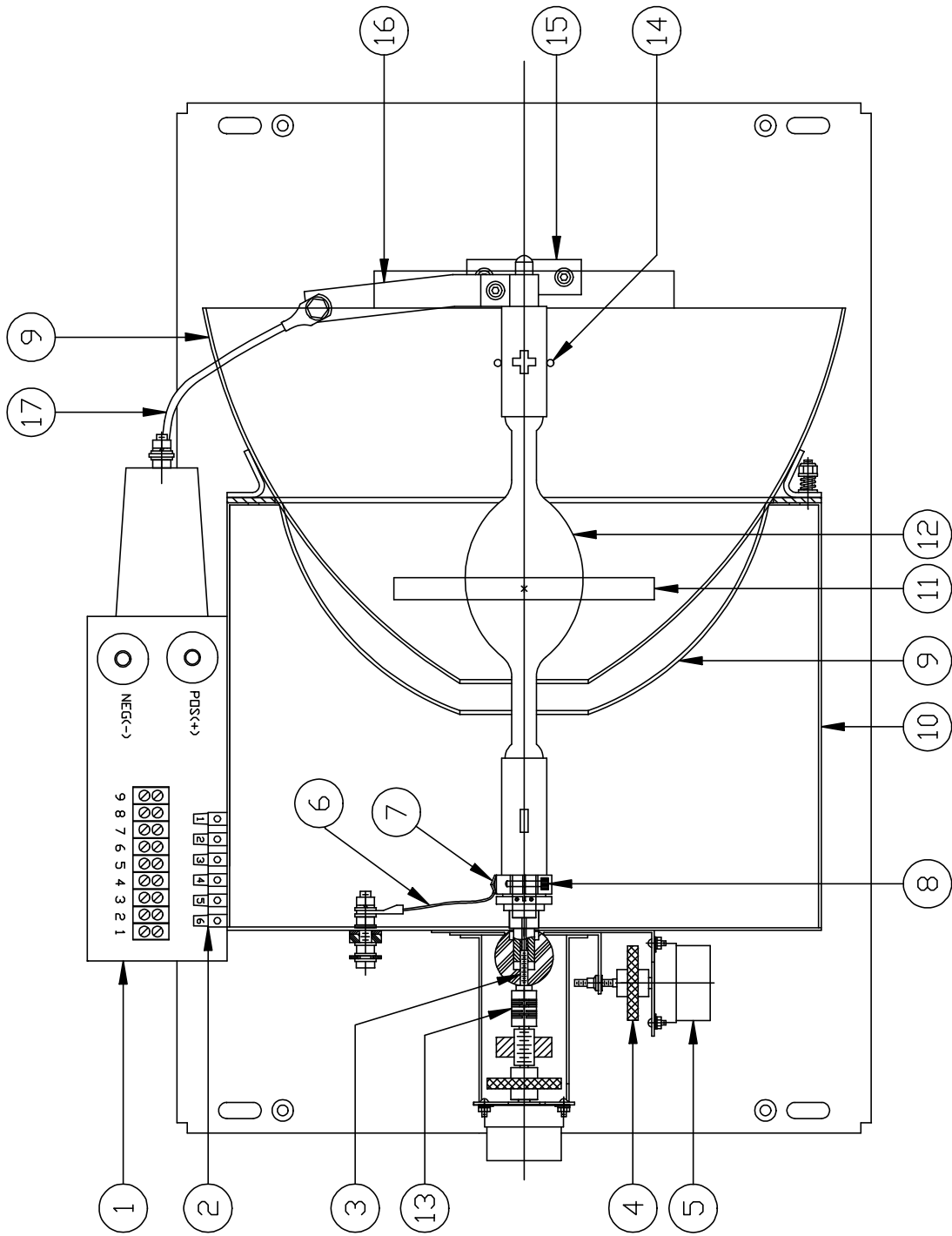

Figure A-6: Plenum , All Models (Top View)

#	Description	Part Number
1	Igniter, IGA-10	116715-001
	Igniter, IGA-15M	117124-001
	Igniter, IGA-25DC	196370-001
2	Terminal Board, TB4	586210-602
3	Focus Screw	195182-001
4	Wheel, Manual Lamp Adjustment	195190-001
5	Motor, Synchronous, Lamp Adjustment, 50 RPM	582000-002
6	Flex Braid Negative Lamp Lead ( <i>SLC</i> )	195224-002
7	Negative Lamp Connector	194513-003
8	Allen Screw, #8-32 x 0.75 in L	598931-046
9	Reflector, 2000-3000 W Lamp ( <i>SLC 20, 30</i> )	195206-003
	Reflector, 4000 W ( <i>SLC 40, 45</i> )	195891-001
	Reflector, 4500 W ( <i>SLC 45R</i> )	195710-001
	Reflector, 7000 W ( <i>SLC 70</i> )	195572-001
10	Cover Support, Plenum	195171P001
	Front Support, Plenum	195172P001
11	Magnet, Arc Stabilizer	515000-092
12	Xenon Lamp, 7000 W *	CXK-70
	Xenon Lamp, 1600 W Adapter *	CXL-16S
	Xenon Lamp, 2000 W *	CXL-20
	Xenon Lamp, 3000 W *	CXL-30
	Xenon Lamp, 4000 W *	CXL-40
	Xenon Lamp, 4500 W *	CXL-45
	Xenon Lamp, 6000 W *	CXL-60
13	Shaft Coupling	195532-001
14	Lamp Support Arm	193959-001
15	Insulator, Lamp Support	193958-002
16	Forward Adapter, Positive Connector	191925-002
17	Lamp Lead, Positive Connector ( <i>SLC 20, 30</i> )	193718-001
	Lamp Lead, Positive Connector ( <i>SLC 40</i> )	195446-001
	Lamp Lead, Positive Connector ( <i>SLC 45, 70</i> )	195446-002

\* Specify SLC model number when ordering.

**Table A- 6: Parts List for Plenum, All Models (Top View)**

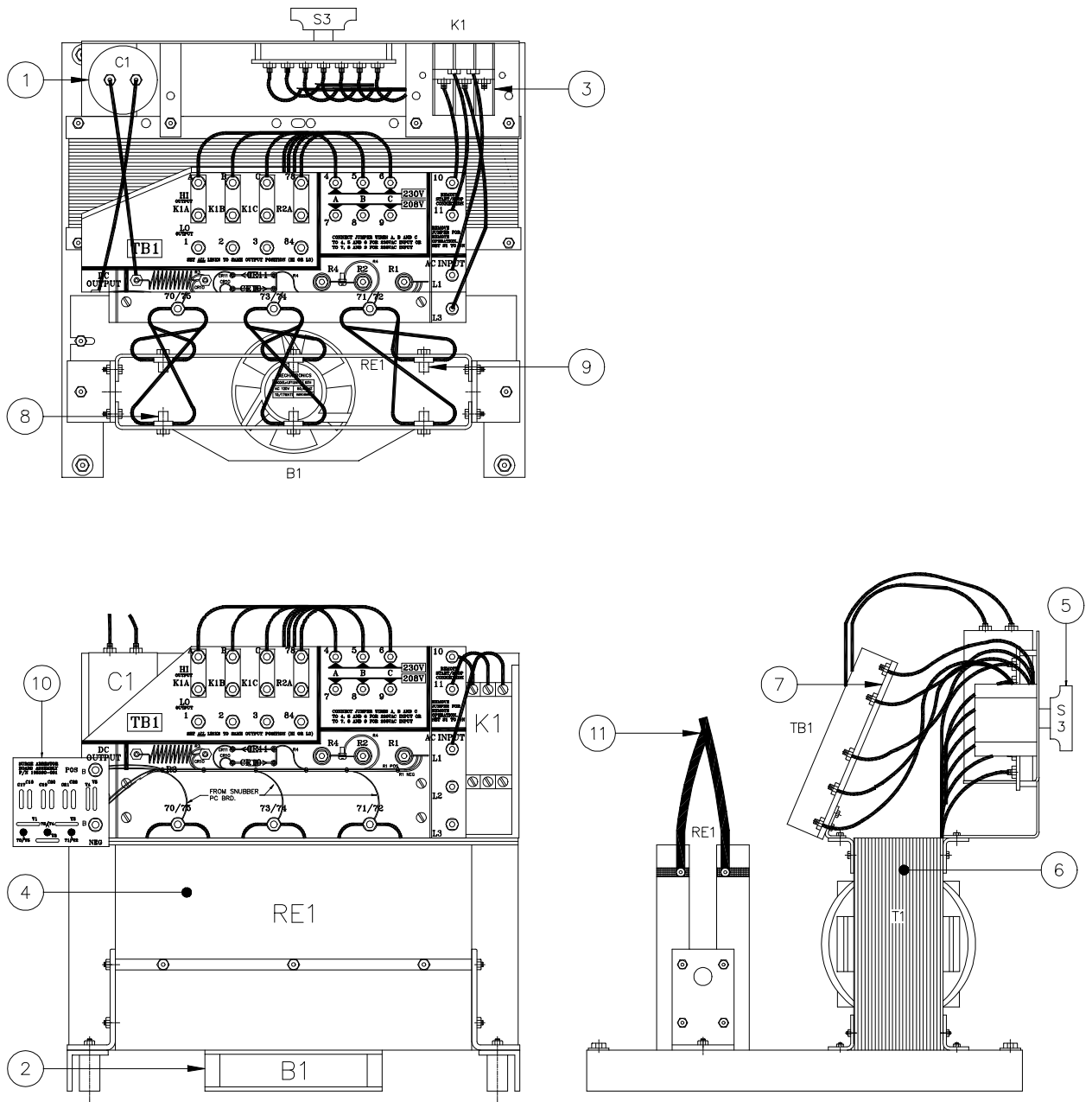

Figure A-7: Power Supply

#	Description	Part Number
1	Capacitor (C1) (SLC 20, 30)	530106-302
	Capacitor (C1) (SLC 40, 45, 70)	530122-009
2	Blower, Fan, SLC (B1)	522000-001
3	Contactor, Relay (K1) 120V, (SLC 20, 30)	571320-001
	Contactor, Relay (K1) 120V, (SLC 40,45,45R,70)	571340-004
	Contactor, Relay (K1) 230V, (20/30)	571320-002
	Contactor, Relay (K1) 230V,(SLC 40,45,45R,70)	571340-001
4	Heat Sink Assembly (RE1) (SLC 40)	114099-001
	Heat Sink Assembly, (RE1) (SLC 20)	114109-001
	Heat Sink Assembly, (RE1) (SLC 30)	114109-002
	Heat Sink Assembly (RE1) (SLC 45, 45R, 70)	195569-001
5	Tap Switch Assembly, Lamp Current Adjustment	111972-002
6	Transformer, 208/230 VAC, 60 Hz (T1) (SLC 30)	115948P001
	Transformer, 208/230 VAC, 60 Hz (T1) (SLC 20)	116845P001
	Transformer, 208/230 VAC, 60 Hz (T1) (SLC 40)	116994P001
	Transformer, 380/415 VAC, 50 Hz (T1) (SLC 40)	119384P001
	Transformer, 380/415 VAC, 50 Hz (T1) (SLC 20)	194701P001
	Transformer, 380/415 VAC, 50 Hz (T1) (SLC 30)	194702P001
	Transformer, 380/415 VAC, 50 Hz (T1) (SLC 45, 45R, 70)	195775-004
	Transformer, 208/230 VAC, 60 Hz (T1) (SLC 45, 45R, 70)	195775P001
7	Control Assembly, 60 Hz (TB1) (SLC 40, 45, 7/	114173-001
	Control Assembly, 60 Hz (TB1) (SLC 20, 30)	114173-002
	Control Assembly, 50 Hz (TB1) (SLC 30, 40, 45, 70)	114173-010
	Control Assembly, 50 Hz (TB1) (SLC 20)	114173-011
8	Diode, Reverse Polarity, Negative (-), 600 VAC, 125 Amp	541108-010
	Diode, Reverse Polarity, Negative (-), 600 VAC, 85 Amp	541109-004
	Diode, Reverse Polarity, Negative (-), 1000 VAC, 100 Amp	541109-006
9	Diode, Normal Polarity, Positive (+), 600 VAC, 125 Amp	541108-009
	Diode, Normal Polarity, Positive (+), 600 VAC, 85 Amp	541109-003
	Diode, Normal Polarity, Positive (+), 1000 VAC, 100 Amp	541109-005
10	Surge Arrester Board Assembly	195390-001
11	DC Cable Kit (SLC 20, 30, 40)	194657-001
	DC Cable Kit (SLC 45, 45R, 70)	195549-001

Table A-7: Power Supply

---

---

# Appendix B

---

---

## Appendix B: Additional Diagrams

---

Appendix B contains additional support information in the form of circuit diagrams for the igniters, and front and side views of the SLC Console, including dimensions.

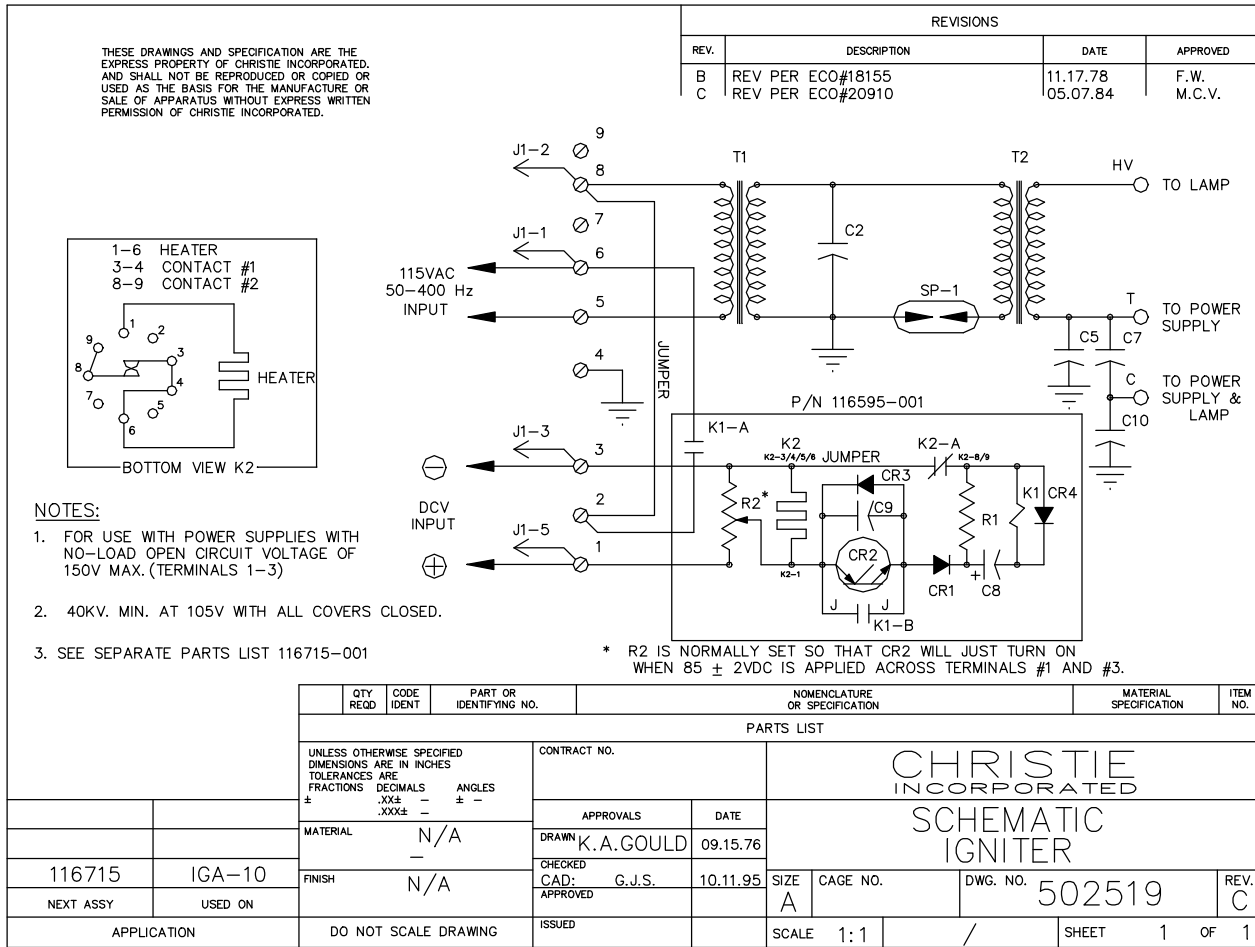

**Figure B-1: Schematic Diagram for IGA-10 Igniter (P/N 502519)**

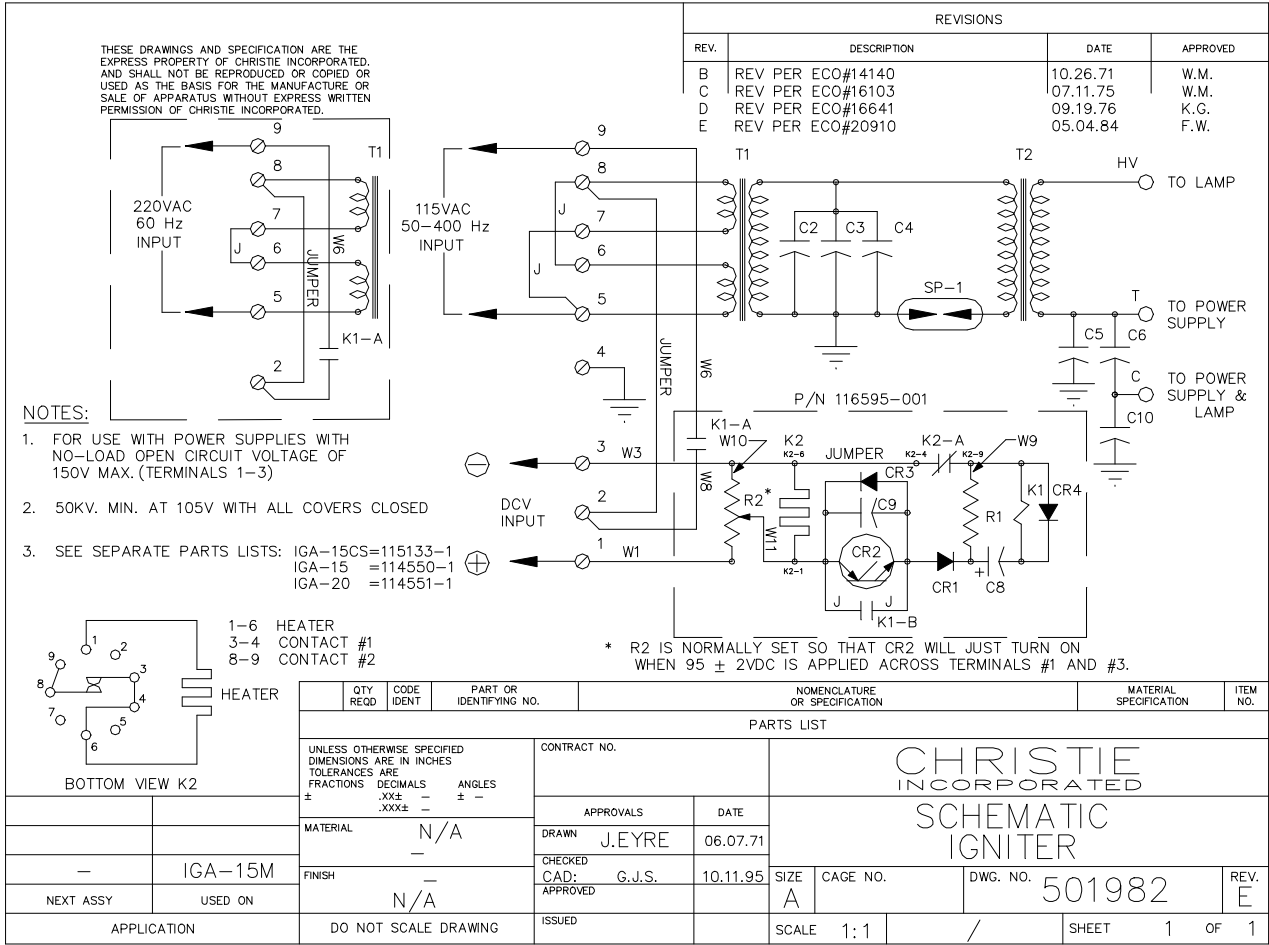

Figure B-2: Schematic Diagram for IGA-15M Igniter (P/N 501982)

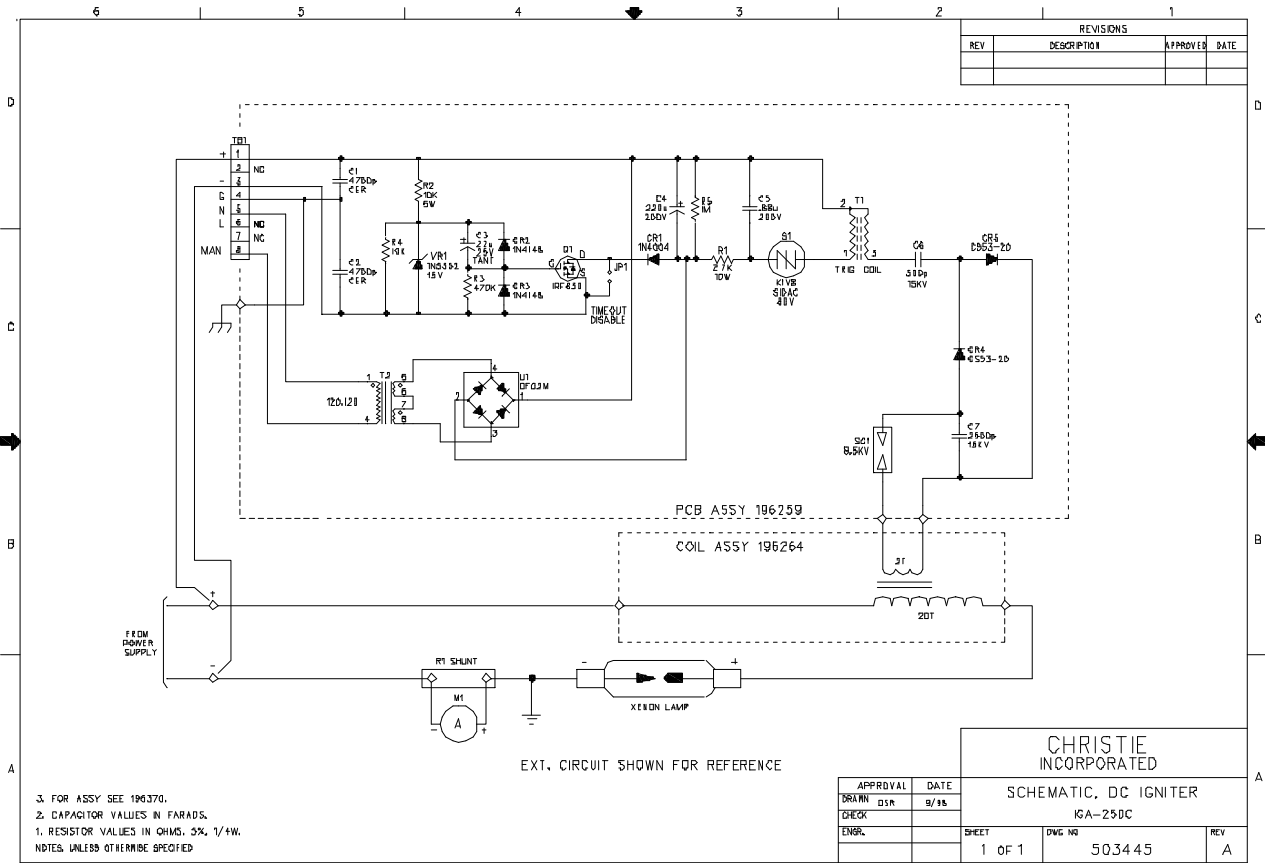

Figure B-3: Schematic Diagram for IGA-25DC Igniter (P/N 503445)



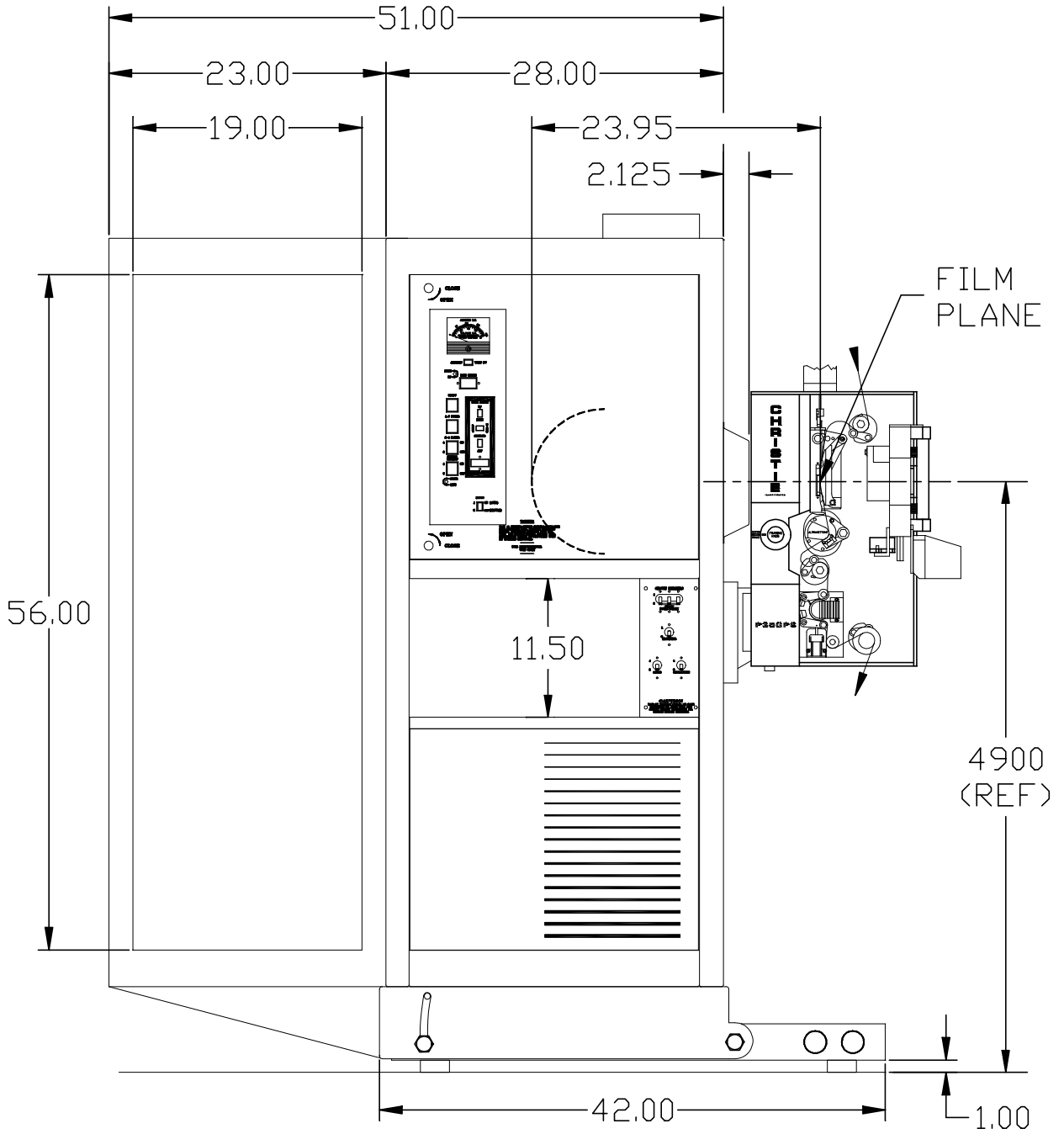
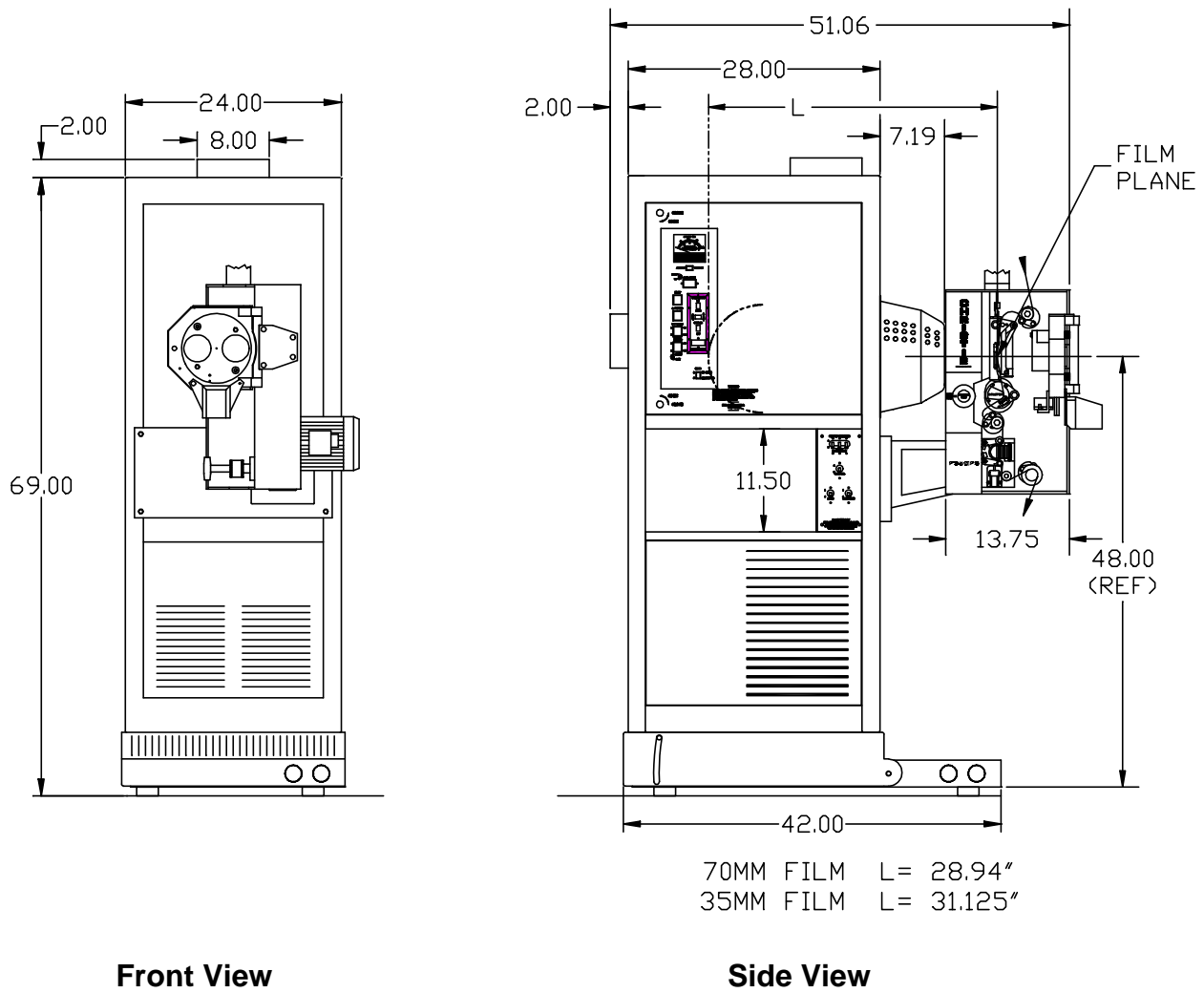

Figure B-4: SLC 20-CC20, SLC 30-CC25 Console (Side View)



**Figure B-5: Console SLC 40-CC40, SLC 45-CC70, SLC 70-CC70**