

Film-Tech

The information contained in this Adobe Acrobat pdf file is provided at your own risk and good judgment.

These manuals are designed to facilitate the exchange of information related to cinema projection and film handling, with no warranties nor obligations from the authors, for qualified field service engineers.

If you are not a qualified technician, please make no adjustments to anything you may read about in these Adobe manual downloads.

www.film-tech.com

OPERATING INSTRUCTIONS

MODEL 3000
XENON LAMPHOUSE
AND POWER SUPPLY
RPS - X40/30

Optical Radiation Corporation

6352 N. Irwindale Avenue, Azusa, California 91702 • (213) 969-3344

ISSUED MAY 1972

TABLE OF CONTENTS

SECTION		PAGE
	LIST OF ILLUSTRATIONS/DRAWINGS.	ii
	CAUTION WARNINGS.	iii
1	INTRODUCTION.	1-1
	1-1 General	1-1
	1-2 Receiving/Handling.	1-1
	1-3 Description/Specifications.	1-2
	1-4 Safety.	1-10
2	INSTALLATION.	2-1
	2-1 Location.	2-1
	2-2 Power Connections	2-3
	2-3 Installation of Dichroic Filter	2-9
	2-4 Installation of Lamp.	2-10
3	OPERATION	3-1
	3-1 General	3-1
	3-2 Lamphouse	3-1
	3-3 Power Supply.	3-3
	3-4 System Start Up	3-4
	3-5 Shut Down	3-6
4	OPTICAL ALIGNMENT	4-1
	4-1 General	4-1
	4-2 Description of Lamp Focus Adjustments	4-1
	4-3 Initial Set Up.	4-1
	4-4 Alignment	4-2
5	MAINTENANCE	5-1
	5-1 Main Transformer and Other Components	5-1
	5-2 Circuit Breaker Overload Protection	5-1
	5-3 Fan and Motor	5-1
	5-4 Primary Power and Secondary Leads	5-2
	5-5 Cleaning Optics	5-2
	5-6 Replacement of Lamp	5-3
	5-7 Trouble Shooting.	5-5
6	LAMP WARRANTY	6-1
7	SPARE PARTS LIST.	7-1

*Exhaust
2-8
300' CFM
PER
LAMP.*

LIST OF ILLUSTRATIONS/DRAWINGS

FIGURE/PART NO.		PAGE
1-1	Model 3000 Xenon Lamphouse.	1-4
1-2	Model RPS-X40/30 Power Supply . . .	1-8
2-1	Cable Entrance Ports, RPS-X40/30 Power Supply.	2-3
2-2	Current Regulator RPS-X40/30 Terminal Board.	2-6
4-1	Typical Bright Spot on Screen . . .	4-3
4-2	Typical Out of Adjustment Screen Patterns.	4-5
5-1	Model RPS-X40/30 Power Supply, Schematic Diagram	5-6
5-2	Model 3000 Lamphouse, Schematic Diagram	5-8

		SECTION
1141036	35mm Front Adapter Assembly	7
1141664	Center Bulkhead Assembly.	7
1141666	Lower Wrap Assembly	7
1141665	Upper Wrap Assembly	7
1141661	Igniter Assembly.	7

TABLE		PAGE
1-1	Installation Hardware	1-3
1-2	Lamphouse, General Specifications .	1-6
1-3	RPS-X40/30 Power Supply, General Specifications.	1-10
2-1	Recommended Primary Wire and Fuse Sizes	2-4
2-2	Secondary Cable Sizes	2-7

CAUTION WARNINGS

WARNING

THE XENON LAMP USED IN THE ORCON PROJECTION SYSTEM IS HIGHLY PRESSURIZED AND SUBJECT TO POSSIBLE EXPLOSION. DO NOT REMOVE COVER OF LAMPHOUSE UNTIL XENON LAMP HAS COOLED FOR AT LEAST 15 MINUTES, AND LAMP HAS BEEN REMOVED WITH PROTECTIVE REMOVAL TOOL.

WARNING

THE XENON LAMP USED IN THE ORCON PROJECTION SYSTEM IS OF EXTREME INTENSITY. DO NOT LOOK DIRECTLY AT LAMP WHEN ON FOR PROLONGED PERIODS OF TIME OR SERIOUS EYE DAMAGE MAY RESULT.

SECTION I - INTRODUCTION

1-1 GENERAL

This technical manual provides installation, operation and maintenance instructions for the ORCON Xenon Lamphouse Model 3000 and Xenon Current Regulator RPS-X40/30 (Power Supply). The system is manufactured by Optical Radiation Corporation (ORC), Azusa, California, and is compatible with any 35 or 70mm motion picture projection system. Do not attempt installation, operation or maintenance of equipment until the contents of this manual are thoroughly understood. Damage to equipment or injury to personnel may result if all instructions are not carefully followed.

1-2 RECEIVING-HANDLING

Remove all packing material from around the lamphouse and power supply and carefully inspect for damage that may have been caused by shipping. Any claims for loss or damage that may have occurred in transit must be filed by the buyer with the carrier. Copy of bill of lading and freight bill will be furnished on request if required. Table 1-1 is a list of installation hardware included with each lamphouse.

When requesting information concerning the equipment, be sure to furnish STOCK, SERIAL and MODEL numbers.

Removal of Power Supply Container

- a. Orient power supply so that proper side is up.
- b. Remove lag bolts from bottom edge of power supply packing.
- c. Lift upper packing container off.
- d. Locate and remove forklift skid.

Removal of Lamphouse Container

- a. Slit top side of container along taped seam.
- b. Remove side packing and lift lamphouse from container.

1-3 DESCRIPTION/SPECIFICATIONS

Model 3000 Xenon Lamphouse (See Figure 1-1)

The Model 3000 is recommended for screen sizes up to 55 feet in width when used with an X-4000 xenon bulb. The Model 3000 provides 30,000 lumens open shutter illumination with the X-4000 xenon bulb operating at a nominal current of 100 amperes, and 20,000 lumens with the X-2500 xenon bulb operating at 65 amps DC, when using an f1.7 projection lens. Screen brightness distribution of not less than 75 percent is assured when the system is properly aligned, providing the optimum film presentations.

The system has a standard nine-inch optical centerline and the base of the system adapts to the mounting plate of all projector pedestals. The xenon lamphouse is equipped with a high performance aspheric reflector, necessary control circuitry, system status displays, ignition system, safety interlocks, dichroic filter, manual light douser, three axis lamp adjustment, and self-contained cooling system. Table 1-2 is the general lamphouse specification.

Table 1-1. Installation Hardware

1 each	3/16 Plas-T-Key
1 each	9/64 Allen Hex Key (Short Arm)
1 each	1/8 Allen Hex Key (Short Arm)
1 each	3/32 Allen Hex Key (90°)
4 each	1/4-20 x 2" Flathead Screws
4 each	1/4 SAE Flat Washers
4 each	1/4 Lock Washers
4 each	1/4-20 Hex Nuts
1 each	1/4 Xcelite No. 8 (Special Tool)

DICHROIC FILTER

MANUAL
LIGHT
DOUSER

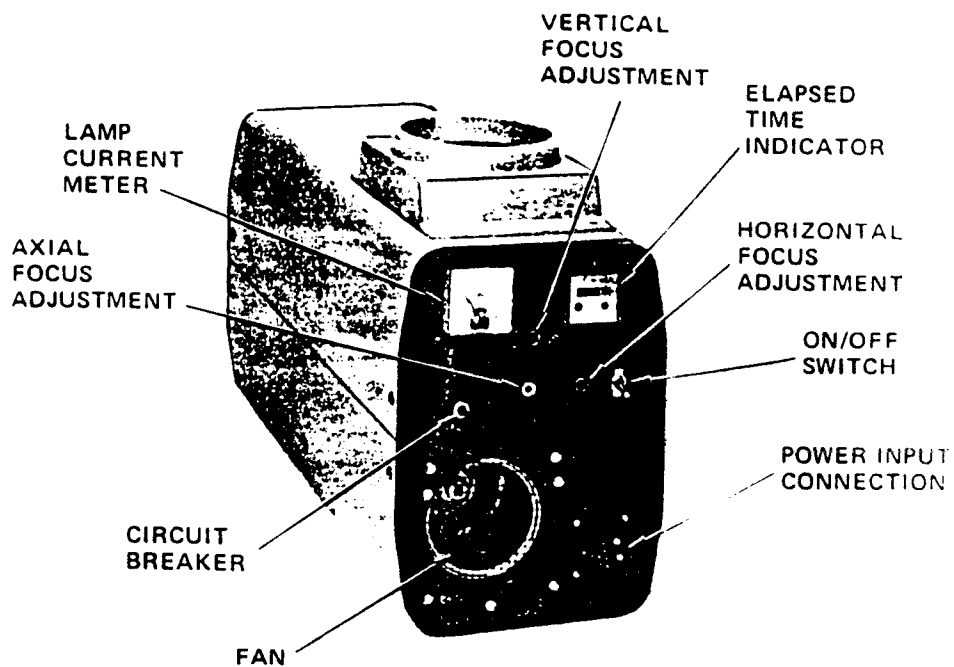
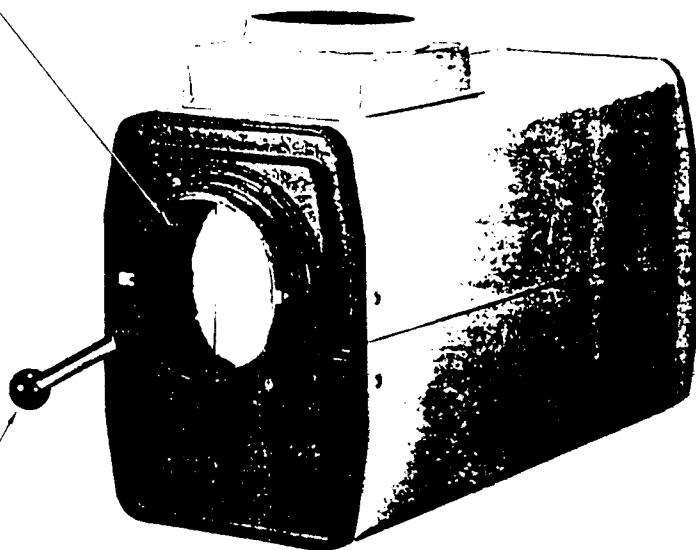

Figure 1-1. Model 3000 Xenon Lamphouse

The high performance aspheric reflector is made of metal and is specifically designed to be used with the X-4000 and X-2500 xenon lamp. The metal construction provides a reflector which is essentially good for the life of the system, and in case of an abrupt lamp failure, does not need to be replaced.

A hot mirror dichroic filter is mounted in the front section to eliminate film damaging infrared radiation. The filter reflects the infrared rays away from all critical components within the lamphouse, and transmits the visible light in the direction of the film gate.

All the necessary controls are located on the rear panel for easy access. The controls are designed for both manual and automated usage with the RPS-X40/30 Power Supply. A separate 115 VAC, 60 Hz power source is supplied to the lamphouse for operation of all components, and has a two-pole circuit breaker for circuit protection.

Air flow and door safety interlocks are incorporated on the system to prevent or discontinue operation of the lamp if the interlock switches are not closed. The lamphouse self-contained cooling system is specifically designed to insure that the operating temperatures of the xenon lamp, reflector, dichroic filter and critical components do not exceed their safe operating limits. The air flow switch is set at the minimum value of air flow acceptable to maintain the proper environmental conditions.

The ignition system provides a high voltage RF pulse of approximately 25,000 volts to ionize the xenon gas between the lamp electrodes, and enables sustained direct current lamp operation from the RPS-X40/30 Power Supply. The control circuit provides a 115 VAC control signal which starts the power supply and then provides a command signal to the ignition system which in turn produces the high voltage pulse. The high voltage areas are limited to prevent break-over, and are not accessible when the system is properly set up for operation.

Initial installation requires alignment of the pedestal base to align the reflector optical axis with the projection lens axis. Factory tools are available for this operation which is simplified due to the symmetry of the optical system. Once the reflector optical axis is aligned at installation, the base is secured to the pedestal; subsequent focus adjustments are accomplished by the three axis adjustments which move the lamp within the stationary reflector.

The above combination of features is unique with Optical Radiation Corporation's xenon projection lamphouse and has been optimized with advanced engineering techniques to provide simplicity, reliability and safety in installation and continued long term operation.

Table 1-2. Lamphouse, General Specifications

BULB	DC CURRENT	LUMEN* OUTPUT	POWER	LIFE	FIELD UNIFORMITY
X-4000	100	30,000	2200 Watts	1250 Hour	75% Minimum
X-2500	65	20,000	1600 Watts	1500 Hour	75% Minimum
*Open aperture, f/1.7 Projection Lens					

X-4000 and X-2500 Xenon Lamp

The xenon lamp is constructed of special quality quartz which prevents transmission of the energy in wavelength bands which create ozone. The lamp is constructed using the latest sealing and electrode design techniques developed over the past decade for military and aerospace applications. The result is a lamp which is extremely rugged and of highest quality and reliability. In addition, the lamp is specifically designed for stable operation over a wide current range, and requires no external magnetic fields for stabilization.

Power Supply (See Figure 1-2)

The power supply is designed specifically for operating the X-4000 or X-2500 Xenon Lamp in the Model 3000 Xenon Lamphouse. Table 1-3 is the specifications for the power supply. The power source is current regulated to provide steady light output independent of incoming line voltage fluctuations and changing lamp characteristics caused by aging. This feature provides optimum projection quality.

This power source consists of a single phase power transformer, primary contactor, silicon diode rectifier, 5% current ripple filter, remote or standard amperage control capability, reduced current standby mode, control and power overload protection, and cooling fan.

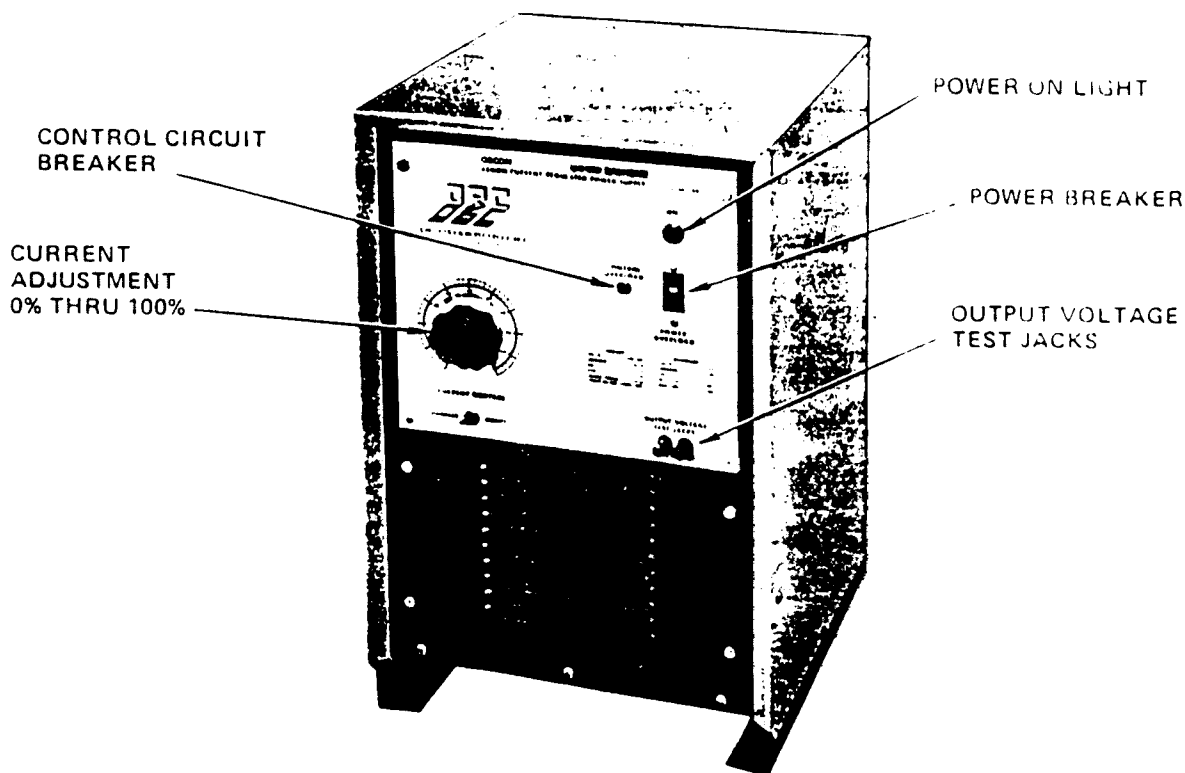

Figure 1-2. Model RPS-X40/30 Power Supply

The power supply operates by supplying a command signal from the lamphouse when the safety interlocks are closed. This signal energizes the primary contactor, thus starting the fan motor and providing the necessary DC open circuit voltage for lamp ignition. When the proper open circuit voltage is reached (84 VDC), the high voltage RF ignition pulse is generated across the lamp. The power supply then sustains DC operation of the lamp.

Overload protection is provided in both the control circuit and the power circuit in case of abnormal conditions. Current.

control is provided by means of a rheostat on the front panel. A STANDARD/REMOTE switch is provided for remote current control if required. This switch can also be used as a standby mode if desired by switching to REMOTE while the lamp is running. The current control is obtained from a 30 volt secondary winding which supplies the variable control voltage (variable by means of the amperage CURRENT CONTROL on the front panel) to the magnetic amplifier. The result is a smooth continuous current adjustment for precise current setting which can be accomplished while the lamp is operating.

The system is equipped with the necessary inductive and capacitive elements to maintain a current ripple of less than 5%. The low ripple factor eliminates any flicker in the film presentation inherent in many systems which do not have adequate filtering. In the case of large screen projection, most shutters are opened to increase light, and it is therefore important to have adequate filtering for a quality film presentation.

A hinged access door is located on the left side of the power supply for convenience and ease of electrical installation. Behind the access door are all the necessary power and control connections required for installation. Voltage test jacks are incorporated on the front panel for trouble shooting.

Table 1-3. RPS-X40/30 Power Supply, General Specifications

Current Ranges Amperes	Rated Output Amps @22V 100% Duty Cycle	Input at Rated Load, 60 Hz			Cur. Rip.	Cur. Reg.	Approx. Weight Net Ship	Dim. in Inches
		Open Circuit Volts	Amps/1 ϕ 220/208 Volt	KW				
40-100	100	84	* 25 **15	*5.5 **3.1	<5%	<5%	235 260	15" W 17.5"D 24" H
*X-4000 Bulb **X-2500 Bulb								

1-4 SAFETY

Before attempting to make primary or secondary connections, change parts or make repairs, be sure the power source is completely disconnected from the main power line.

Before performing maintenance on the lamphouse, the lamphouse power should be disconnected.

Caution should be exercised in taking voltage measurements when troubleshooting the unit. Always avoid contact between any part of the human body and any current carrying part of the power source.

Whenever it is necessary to be exposed to or handle the xenon lamp, follow the necessary precautions outlined in the front of the manual.

When installing the power source, be sure that a ground cable is connected from the stud labeled GRD (on the primary connection board) to a suitable ground.

The following definitions apply to WARNINGS, CAUTIONS and NOTES found throughout this manual.

WARNING

INSTALLATION, OPERATING AND MAINTENANCE PROCEDURES, PRACTICES, ETC., WHICH WILL RESULT IN PERSONNEL INJURY OR LOSS OF LIFE IF NOT CAREFULLY FOLLOWED.

CAUTION

INSTALLATION, OPERATING AND MAINTENANCE PROCEDURES, PRACTICES, ETC., WHICH WILL RESULT IN DAMAGE TO EQUIPMENT IF NOT CAREFULLY FOLLOWED.

NOTE

INSTALLATION, OPERATING AND MAINTENANCE PROCEDURES, PRACTICES, ETC., WHICH ARE ESSENTIAL TO EMPHASIZE.

SECTION 2 - INSTALLATION

2-1 LOCATION

Lamphouse Location

The lamphouse should be purchased with a mounting plate (Suffix MP) which fits into the track of a standard 35/70mm projector base on the top of the pedestal. The lamphouse MP is fastened by means of 1/4-20 flat head bolts installed through the slots in the projector base. One bolt per side is adequate for restraining the lamphouse. The working distance from the aperture to the front bulkhead where the light cone mounts is 7½ inches.

When used with the various film transport systems and projectors which do not use the standard base, such as the Norelco, a working distance of 7½ inches and an optical centerline of 9 inches should be observed. In these cases, a special adapter can be supplied by Optical Radiation Corporation.

Power Supply Location

A good installation is essential if the power source is to provide satisfactory and dependable service. Proper component operating temperatures are maintained by the air stream produced by the power source fan unit. Therefore, the power source should be located so that the air passing into the front and bottom of the power source is not restricted. The back of

the power source should be located at least 12 inches from the wall so that the air passage from the fan will not be blocked.

The power supply should be located in an area where a minimum amount of dirt or dust will be drawn into the air stream. Preventive maintenance will consist of periodically removing the cover and blowing out the dust accumulation inside the power supply. For this reason it is desirable to locate the unit so that the left side cover can be easily opened without obstruction.

The distance between the power supply and lamphouse is not critical as long as adequate conductor size is used to prevent any noticeable voltage drop. In most cases, the power supply is located next to the projector for convenience. Acceptable voltage drop is approximately 1 volt at 100 amps. A cable can be furnished which plugs into the lamphouse and has lugged connectors which fasten in the power supply. The length of cable desired should be specified at time of purchase. If the distance between the lamphouse and power supply is significant, a remote current control can be installed.

The input AC control and DC power enters the back of the unit as shown in figure 2-1. The conduit trough for convenience can be located on the floor in the vicinity of the conduit connector knockouts.

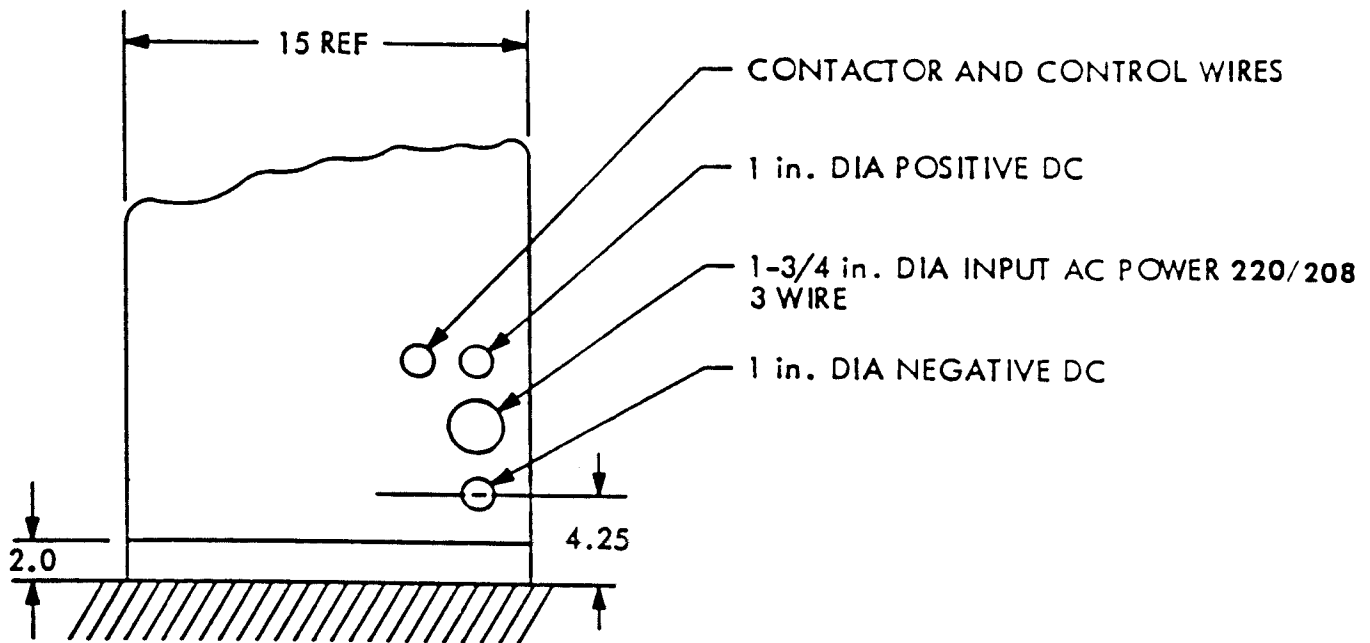

Figure 2-1. Cable Entrance Ports, RPS-X40/30 Power Supply

2-2 POWER CONNECTIONS

Primary Power to Power Supply

The power supply is designed to operate on 220 volts, 60 Hz, single phase AC power, three wire. Facilities for operation on other primary voltages, if ordered, are incorporated at the factory. These power sources should be operated from a separately fused or circuit breaker protected branch circuit.

Primary power connections are made directly to the two line terminals marked LINE on the terminal board. The third wire (or ground) should be hooked to the terminal marked GRD. The terminal board is located directly behind the access door on the side panel of the power source. A standard size conduit hole is provided on the back panel next to the access door to allow bringing the two primary power leads and ground wire into the power source. The primary leads should be enclosed in solid or flexible conduit in order to decrease high frequency radiation in the event it should leak into the primary leads, and to meet the necessary electrical codes. Insert the two primary leads and ground through the center access hole as shown in figure 2-1.

Ensure the ground wire is connected to the terminal labeled GRD (Ground) on the corner of the primary board. Refer to table 2-1 for recommended primary wire and fuse sizes to use for the various operating voltages.

Table 2-1. Recommended Primary Wire and Fuse Sizes

Primary Wire Size - AWG	Fuse Size in Amps
220 V No. 8	220V 60

WARNING

BE SURE THE GROUND WIRE IS CONNECTED TO THE GROUND TERMINAL IN THE LINE DISCONNECT SWITCH BOX. IF NOT, CONNECT IT TO A GROUNDING ROD, WATER PIPE OR USE WHATEVER GROUNDING PROCEDURE THAT IS ACCEPTABLE TO THE LOCAL ELECTRICAL CODE AND INSPECTION. THE STUD, LABELED GRD, IS CONNECTED TO THE POWER SOURCE CHASSIS. DO NOT CONNECT ANY OF THE LINE LEADS TO THIS TERMINAL AS THIS WILL RESULT IN A HOT CHASSIS.

Since these power sources are designed to operate from more than one line voltage, a jumper link arrangement on the terminal board is provided to allow matching the primaries of the power source's transformer to the incoming line voltage. Check the position of the jumper links on the terminal board. The jumper links are connected for the highest line voltage from which the power source is designed to operate. To connect the power source properly for the line voltage available, position the jumper links as illustrated in figure 2-2.

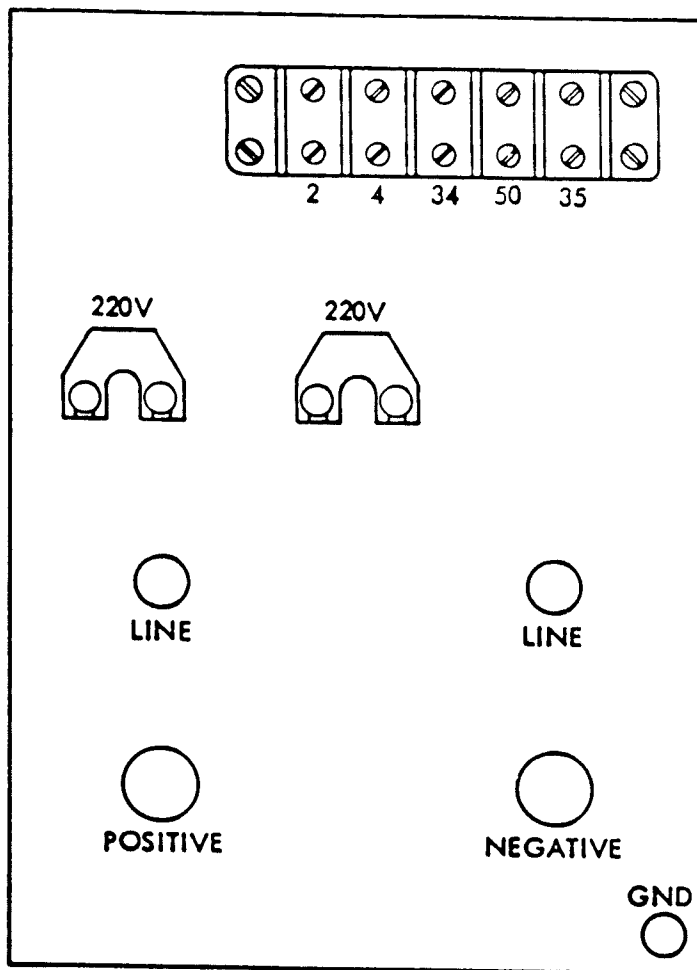

Figure 2-2. Current Regulator RPS-X40/30, Terminal Board

Secondary DC & Control Cables to Power Supply and Lamphouse

DC Power Cables/Power Supply

Generally, the secondary DC and control cables will be factory supplied since a special connector is required to connect to the lamphouse. If the power supply is located next to the projector, a cable length of 8 feet should be satisfactory. If special length cables are required, please indicate the necessary length so the proper gauge DC conductor can be used. The cable is formed with lugged ends to facilitate hook-up to the power supply.

Table 2-2. Secondary Cable Sizes

Wire Designation	220/208 VAC 60 Hz Termination
+ DC White	Positive DC (Red)
- DC Black	Negative DC (Blk)
#18 Orange	Line 1
#18 Red	Line 2
#18 Yellow	1T Terminal 2
#18 Green	GRD
Internal	Jumper 1T Terminal 4 to Line 1

As shown in figure 2-1, the positive DC cable goes through the upper conduit port and connects to the positive terminal, and the negative DC lead goes through the lower conduit port and connects to the black negative terminal. These connections are located immediately behind the access door. The control wires in the cable should be routed to the inside access hole. Hook up of the wires is described in table 2-2.

It is recommended that these terminals always be kept clean, and that connections to these terminals are always kept secure. The negative (black) and positive (red) test jack located on

the front panel are connected to the negative and positive secondary terminals respectively and are used for checking power from power supply to lamphouse.

DC Power Cables/Lamphouse

Internal connections are not required in the lamphouse. The connector on the cable harness need only be connected to the lamphouse.

Control AC Power Lamphouse

AC power is furnished to the lamphouse from the power supply control circuit operation. A 5 amp circuit breaker is located on the lamphouse to protect the control circuit.

Automation

To automate the system, the orange or red (or both) wire can be routed through the automation contacts before being wired internally to the power supply.

Remote Current Connections

If remote amperage control is required, a remote rheostat should be connected to terminals 34, 50 and 35 of terminal strip 1T in the power supply (see figure 2-2). The wire size for remote operation should be #14 AWG.

Exhaust Duct

Since the lamps are ozone free and the lamphouse has a self-contained cooling system, it is not necessary to vent the lamps directly outside. However, due to the heat generated by the light source and stray light, venting may be desirable.

CAUTION

IF LAMPS ARE VENTED, IT IS MANDATORY THAT A MINIMUM FLOW CAPABILITY OF 300 CFM BE PROVIDED AFTER COMPENSATION FOR HEAD PRESSURE LOSSES. A FLOW CAPABILITY LESS THAN THIS WILL PREVENT THE INTERLOCK SWITCH FROM CLOSING.

2-3 INSTALLATION OF DICHROIC FILTER (SEE DRAWING 1141036)

The dichroic filter should be installed before installing the lamp. This is accomplished as follows:

a. Remove filter holder (Item 1) from front bulkhead of lamphouse.

CAUTION

WEAR WHITE COTTON OR LINEN GLOVES WHENEVER HANDLING FILTER GLASS. FINGER CONTACT WITH GLASS SURFACE WILL LEAVE BODY OIL MARKS WHICH WILL IMPAIR PERFORMANCE AND CAUSE FRACTURE OF THE GLASS AS A RESULT OF HEAT SPOTS CAUSED BY LOCAL ABSORPTION OF THE ENERGY FROM THE LIGHT SOURCE.

b. While holding filter glass at an angle in a bright light, observe for any unusual stains. If stains are noticed, clean with a mild hand soap and water or an ammonia base household cleaner in an aerosol can. Rinse well with cold water and dry with Kleenex or equivalent if a mild soap is used. If ammonia cleaner is used, dry well with Kleenex after application; no water is required.

c. Set filter holder on bench or equivalent with large diameter resting on bench surface.

d. Remove clips (Item 6) and loosen remaining clips (Item 7) slightly. Filter segment should be installed with coated side facing light source. A black mark is painted on the uncoated side of the filter and should face towards the projector when installed.

e. Slide both filters underneath clips (Item 7) and then tighten clip screws.

f. Install clips (Item 6) and tighten.

g. Mount assembly to front bulkhead of lamphouse.

2-4 INSTALLATION OF LAMP

The initial installation of the xenon lamp can be accomplished before final positioning of the lamphouse as follows:

WARNING

DO NOT APPLY LATERAL PRESSURE AGAINST LAMP WHEN TIGHTENING SET SCREWS. DO NOT LOOK INTO FRONT OF LAMPHOUSE WHILE INSTALLING LAMP UNLESS PROTECTIVE FACE MASK IS WORN.

X-2500 Xenon Bulb

a. Loosen shoulder bolt on mounting plate and pivot lamphouse clear of projector. Remove three screws from front nose section on lamphouse. Loosen screw in lower left hand corner and swing nose section away.

- b. Remove upper wrap from lamphouse by removing four screws.
- c. Remove wing nut, washer, and cap restraining bar from lamp installation/removal tool containing xenon lamp.
- d. Remove orange end cap from installation/removal tool (cathode, threaded end of lamp).
- e. Screw lamp adapter onto cathode end of lamp, while lamp is still secured inside of installation/removal tool.
- f. Insert installation/removal tool (with lamp inside) through front opening of lamphouse and through center opening in mirror until stud end of lamp adapter is captured inside of cathode holder. Tighten set screw in cathode holder using the furnished 3/32 Allen wrench tool.
- g. Using a 1/8 inch Allen wrench, loosen set screw on collar located around anode end of lamp. Remove collar.
- h. Remove installation/removal tool from lamp by pulling straight off.

WARNING

DO NOT VIEW BARE LAMP AND DO NOT EXERT BENDING PRESSURE ON LAMP WHEN REMOVING INSTALLATION/REMOVAL TOOL.

- i. Install anode clamp and cable over anode end of lamp, making sure there is no cable stress on the clamp. Tighten set screw in clamp with a 3/32 Allen wrench tool.
- j. Replace top wrap on lamphouse and reinstall front nose section. System is now ready for operation.

X-4000 Xenon Bulb

a. Loosen shoulder bolt on mounting plate and pivot lamp-house clear of projector. Remove three screws from front nose section on lamphouse. Loosen screw in lower left hand corner and swing nose section away.

b. Remove upper wrap from lamphouse by removing four screws.

WARNING

LEAVE PROTECTIVE PLASTIC WRAP ON BULB UNTIL INSTALLED.
LOOSEN STRING TIE ENDS BEFORE INSTALLING LAMP.

c. Place cathode end of lamp (small end) through front opening in lamphouse, through center opening of mirror until stud end of lamp is captured inside cathode holder. Tighten set screw in cathode holder using the furnished 3/32 Allen wrench tool.

d. Install anode clamp and cable over anode end of lamp, making sure there is no cable stress on the clamp. Tighten set screw in clamp with a 3/32 Allen wrench tool.

WARNING

WEAR PROPER PROTECTIVE CLOTHING BEFORE REMOVING PROTECTIVE PLASTIC WRAP ON LAMP. FACE MASK, GLOVES AND HEAVY COAT SHOULD BE WORN.

e. Remove protective wrap from bulb.

f. Install top wrap and nose section on lamphouse. System is now ready for operation.

SECTION 3 - OPERATION

3-1 GENERAL

Once installation is complete, the system is ready for operation and alignment. The following is a general description of the controls and displays on both the lamphouse and power supply.

3-2 LAMPHOUSE (See figure 1-1)

System Start Switch

When operated with the RPS-X40/30 Power Supply, actuating the SYSTEM ON switch with the 5 amp circuit breaker closed will do the following:

- a. Start blower motor in lamphouse.
- b. Upon interlock closure, contactor in power supply will close (red light on power supply will come on).
- c. Bulb ignition will occur after the proper open circuit voltage has been reached (approximately 3 seconds).
- d. Elapsed time indicator will register hours on bulb.

Automation Controls (External)

Provides same function as "System Start Switch".

Manual Start Switch (Non-standard, Available as Factory Special)

Used as an emergency switch in case the automatic ignition circuit fails to ignite the lamp. To operate switch, the

spring loaded protective guard must be raised and the MANUAL START switch depressed.

CAUTION

DO NOT USE THE MANUAL START SWITCH UNLESS NECESSARY. WHEN USING THE SWITCH, DEPRESS FOR APPROXIMATELY ONE SECOND. PROLONGED CLOSURE DECREASES THE LIFE OF THE ELECTRODES WITHIN THE XENON LAMP.

Ammeter

Meter which indicates DC current to xenon lamp.

Elapsed Time Indicator

Indicator which indicates total number of hours of system operation. Primary function is to monitor the number of hours on the lamp in the system. Lamp warranty card should be used in conjunction with elapsed time indicator. Refer to Section 6 for detailed instruction.

Vertical Focus Adjustment

Actuation of this adjustment moves the beam image up or down in the vertical direction on the screen. This is necessary for achieving even light distribution on the top and bottom of the screen.

Horizontal Focus Adjustment

Actuation of this adjustment moves the beam image horizontally on the screen. This is necessary for achieving even light distribution on the sides of the screen.

Axial Focus Adjustment

Actuation of this adjustment moves the lamp along the optical axis. This adjustment controls the size of the light image on the screen. When the lamp is properly located on this axis, the light beam will fill the screen.

3-3 POWER SUPPLY

Power Overload Circuit Breakers

The POWER OVERLOAD circuit breaker provides protection against overloading of the power source's main components. In the event of a continued overload or abnormal primary current draw, a current transformer (located on the secondary windings of the main transformer) detects this overload condition and causes the circuit breaker to open. The internal contacts of the circuit breaker are connected in series with the primary contactor coil of the power source and the interlocks in the lamphouse. Thus, if the current transformer detects an overload condition, the opening or tripping of the circuit breaker causes the primary contactor to open, suspending lamp current output. The circuit breakers must be ON before the primary contactor of the power source can be energized. If it should open or trip, it must be manually reset.

Control Overload Circuit Breaker

The CONTROL OVERLOAD circuit breaker is a push button 10 ampere circuit breaker (located on the front control panel) which

provides protection against overload in the 30 volt secondary control circuit. This breaker must be manually reset in the event of an overload and must be depressed before the unit can operate.

Current Control Rheostat

The CURRENT CONTROL rheostat is located on the front panel of the power supply. A graduated dial from 0 to 100 percent is provided for accurately setting the current output of the lamp.

The CURRENT CONTROL controls the 1 amp current output from the minimum to maximum (40-100 amperes) of the operating range.

The operator can dial in the exact current required for his application by using this one control. Because this type current control is a continuous contact type, it may be adjusted while the lamp is operating without danger of damage to the lamphouse or power supply.

Indicator Lamp

The indicator bulb will light when the interlocks in the lamphouse have closed. This indicates that power (115 VAC) is provided to the coil of the main contactor on the primary side (input) to main transformer. Under normal conditions the fan in the power supply should start and the xenon lamp ignite.

3-4 SYSTEM START UP

After installation is complete, the system is ready for start up operations as follows:

CAUTION

IF THE XENON LAMPHOUSE IS CONNECTED TO AN EXTERNAL EXHAUST SYSTEM, MAKE SURE THE EXHAUST SYSTEM IS ON BEFORE LAMP IGNITION.

a. Set CURRENT CONTROL on power supply to approximately 50 percent for initial start up. Once proper current control voltage is established, subsequent start ups can be accomplished without adjusting the CURRENT CONTROL rheostat.

CAUTION

IF THE X-4000 BULB IS BEING USED, DO NOT EXCEED 100 AMPERES AND THE BULB SHOULD BE RUN AT NO MORE THAN 40 AMPERES WHEN FIRST INSTALLED. IF THE X-2500 BULB IS BEING USED, 65 AMPERES SHOULD NOT BE EXCEEDED WITH A START UP CURRENT OF 60 AMPERES OR LESS WITH A NEW BULB. WARRANTIES DO NOT APPLY IF THESE CURRENTS ARE EXCEEDED.

b. Actuate main power switch ON. (Red light on power supply will appear lit when lamphouse interlocks are closed. After the proper open circuit voltage is achieved, the xenon bulb will automatically ignite.)

c. Set proper operating current with the CURRENT CONTROL rheostat.

CAUTION

FOR INITIAL OPTICAL ALIGNMENT, THE CURRENT SHOULD BE SET AT 55 AMPERES ON THE X-2500 BULB AND 75 AMPERES ON THE X-4000 BULB UNTIL SATISFACTORY ALIGNMENT IS ACHIEVED. THE CURRENT CAN THEN BE ADJUSTED UPWARDS. INITIAL OPERATING CURRENT SHOULD NOT EXCEED 60 and 90 AMPERES FOR THE X-2500 AND X-4000 BULBS RESPECTIVELY. AS THE LAMP AGES, IT CAN BE ADJUSTED UPWARDS TO A MAXIMUM OF 70 AMPERES ON THE X-2500 BULB AND 100 AMPERES ON THE X-4000 BULB.

3-5 SHUT DOWN

Position ON/OFF switch on lamphouse to OFF; xenon lamp will extinguish. If desired, the xenon lamp can immediately be reignited without damage to the lamp.

SECTION 4 - OPTICAL ALIGNMENT

4-1 GENERAL

The optical alignment of the system can be easily accomplished once the lamphouse is set up properly with respect to the optical axis of the projection lens.

4-2 DESCRIPTION OF LAMP FOCUS ADJUSTMENTS

Three focus screws are provided at the rear of the lamphouse for locating the xenon plasma arc on the optical axis. The focusing screws move the lamp in three directions. The center adjustment moves the lamp in and out along the optical axis, the top adjustment moves the lamp up and down perpendicular to the optical axis, and the right hand adjustment moves the lamp sideways, also perpendicular to the optical axis. The perpendicular movement of the lamp with respect to the optical axis was incorporated into the system to prevent any angular misalignment of the arc with respect to the optical axis. This feature allows optimum focus of the system.

4-3. INITIAL SET UP

Initially position lamphouse so that the projector film gate and the lamphouse are approximately on the same centerline within 1/16 of an inch, and the distance from the film gate to the front of the lamphouse is within approximately 7½ inches.

The approximate positioning of the lamphouse can be accomplished by means of simple measuring devices. Final positioning of the optical axis of the mirror and projector lens is described in Section 4-4.

4-4 ALIGNMENT

Once the lamphouse is set up according to Section 4-3, with the lamphouse optical axis partially aligned with the projection lens optical axis, the lamphouse and projector can be turned on. Turn center focus screw counter-clockwise with the Allen wrench supplied until a bright spot is evident on the screen. If a well defined bright spot does not exist, then turn the top and right hand adjustments until a well defined symmetrical bright spot is evident. At this point it is not important whether the bright spot is in the center of the screen, but it must be symmetrical. This locates the lamp on the optical axis of the collector but not necessarily the projection lens. If the bright spot does not appear in the center of the screen, then the lamphouse should be moved (left, right, up, down, as required) until the bright spot is in the screen center. Once the bright spot is in the center, then the circle of symmetry should be centered on the screen as indicated in figure 4-1. If the bright spot and the circles are not symmetrical, the lamphouse is angularly misaligned. The lamphouse should be aligned so that both the bright spot and the circle of symmetry are symmetrical. At this point the lamphouse should be firmly secured and the center

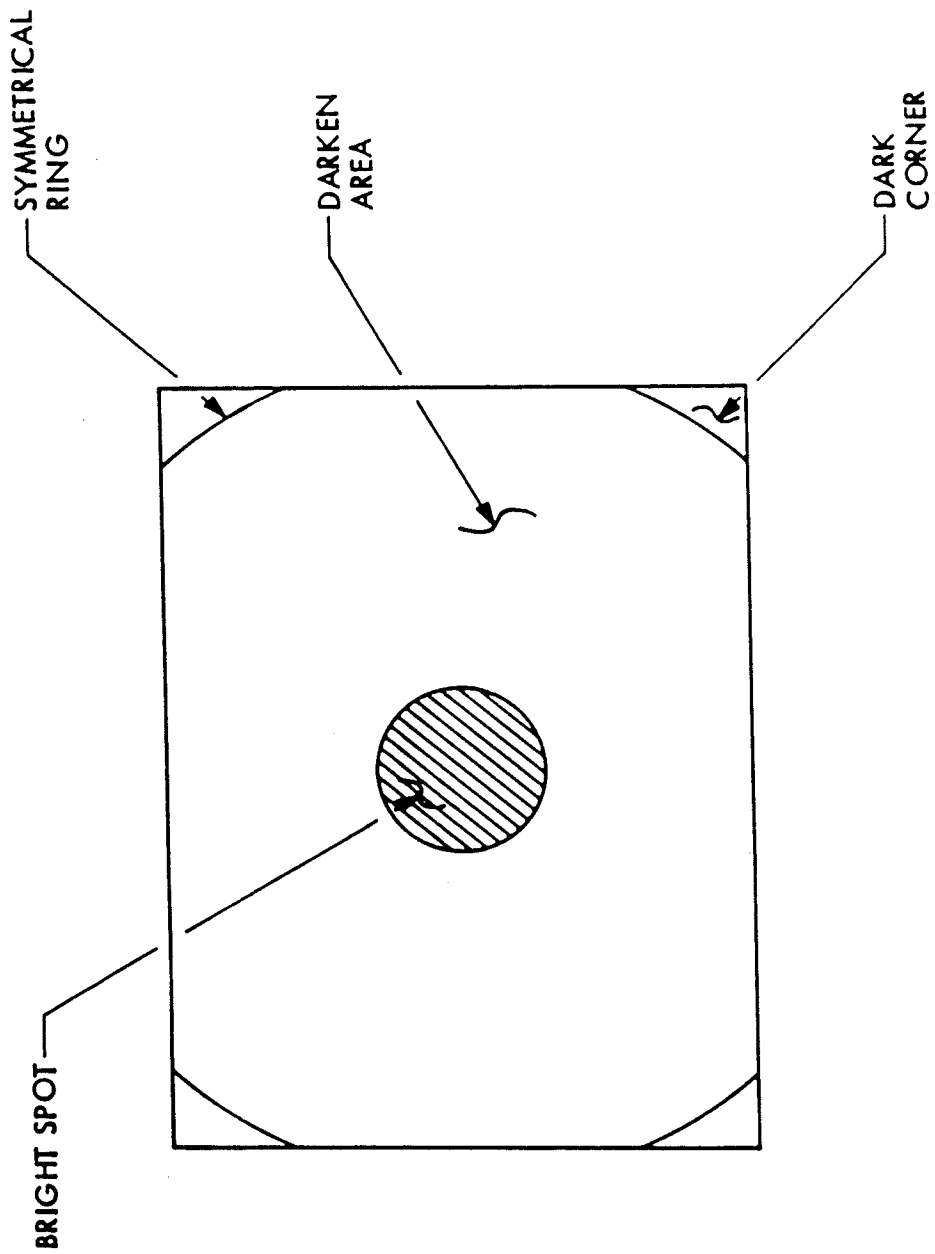

Figure 4-1. Typical Bright Spot on Screen

focusing screw backed off clockwise until the screen is filled with uniform illumination. If one side is brighter than the other, turn the lateral adjustment until the brightness is equal on both sides. If it is brighter on the top or bottom, then turn the vertical adjustment until you have a balanced distribution. Once the unit is aligned, bolt the lamphouse firmly in place.

Obtaining a symmetrical bright spot is important for optimum alignment. When the focus adjustment is turned counter-clockwise, several different patterns, none of which resemble any defined hot spot, may appear as illustrated in figure 4-2. Also, if the adjustment is turned too far counter-clockwise, then a hole will be evident and the adjustment should be turned clockwise until the hole disappears and some form of a bright spot exists.

In figure 4-2, three types of out-of-focus patterns are illustrated. Patterns 1 and 2 require adjustment of the lateral and vertical adjustments to obtain a symmetrical bright spot. Pattern 3 requires an adjustment of a combination of both the lateral and vertical adjustments.

NOTE

Once the system is properly aligned, no adjustments will be necessary until a new lamp is installed. After installation of a new lamp, only the three lamp focus adjustments will be necessary to again achieve optimum alignment.

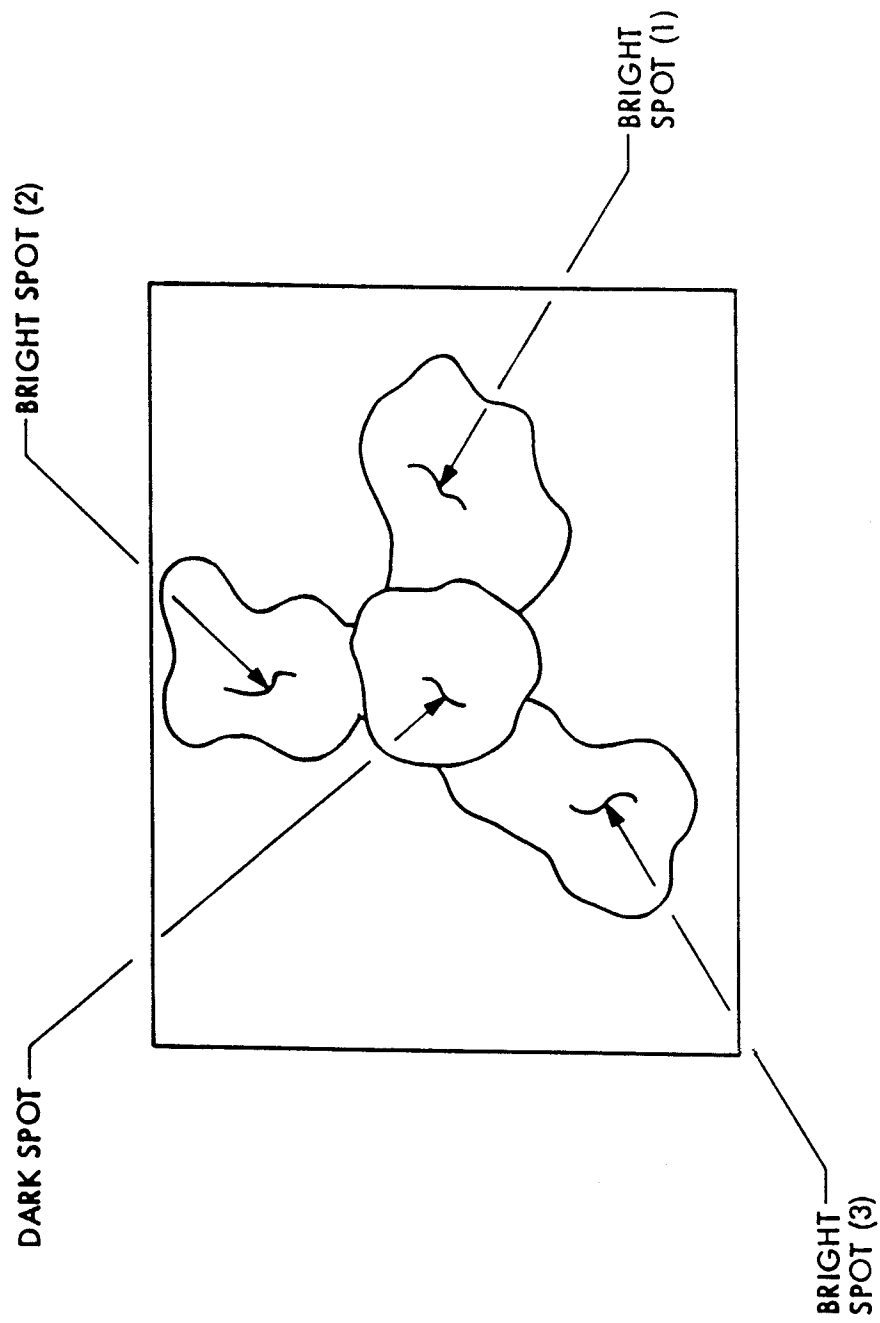

Figure 4-2. Typical Out of Adjustment Screen Patterns

WARNING

BE SURE THE BRANCH CIRCUIT OR MAIN DISCONNECT SWITCH IS OPEN OR PRIMARY INPUT CIRCUIT FUSES ARE REMOVED BEFORE ATTEMPTING TO MAKE ANY INSPECTION OR PERFORM ANY WORK INSIDE OF THE POWER SOURCE. PLACING THE POWER SWITCH IN THE OFF POSITION DOES NOT REMOVE VOLTAGE FROM THE POWER SWITCH TERMINALS INSIDE THE POWER SOURCE.

5-1 MAIN TRANSFORMER AND OTHER COMPONENTS

Clean the components inside of the power source with dry, compressed air. Keep all the doors open to make sure the dust and dirt blows out of the power source.

5-2 CIRCUIT BREAKER OVERLOAD PROTECTION

The circuit breakers will open or trip in the event of a continued overload on the power supply. If the circuit breakers should trip, manually reset them. If they should trip again with a small load in the circuit or when the power source is idling, check the power source's main circuitry.

5-3 FAN AND MOTOR

The power source is equipped with an exhaust fan and requires forced air for adequate cooling for high duty cycles and overload. The fan motor in the power source and lamphouse is manu-

factured with lifetime lubricated sealed ball bearing and no attention is required. The inlet or exhaust screens on the fans should be kept free of build up of residual dust and dirt in order to insure proper cooling. This should be checked periodically.

5-4 PRIMARY POWER AND SECONDARY LEADS

Periodically check primary and secondary leads for tightness. The cables should be inspected frequently and all breaks in the insulation repaired with electrical tape.

Periodically check the secondary terminal connections to determine whether or not the connections are heating. If heating is occurring, the connections should be taken apart and the metal cleaned. A chemical cleanser, such as Cameo or Brillo, should be used to clean the copper or aluminum connections. When chemicals are used to clean the copper or aluminum, they should be rinsed with hot water and covered with anti-oxidants, such as Mobilcote No. 203 or equivalent, to preserve the clean connections.

5-5 CLEANING OPTICS

It is recommended that at least twice annually the reflector and negative lens be cleaned to maintain high screen brightness. In cleaning the optics the following steps should be taken:

- a. With a soft bristled brush, gently brush larger particles off the optics surface.

b. Spray optical surfaces with household ammonia base window cleaner and wipe gently with Kleenex tissue or equivalent until dry and free of residue. Repeat if necessary.

WARNING

DO NOT CLEAN OPTICS WITH BULB IN SYSTEM.

5-6 REPLACEMENT OF LAMP

WARNING

BEFORE REMOVING XENON LAMP, ALLOW 15 MINUTES TO COOL DOWN. WHEN HOT, LAMP IS UNDER HIGHER INTERNAL PRESSURE AND SUBJECT TO EXPLOSION. OBSERVE CAUTION WARNINGS IN FRONT OF MANUAL.

X-2500 Xenon Bulb

a. Loosen shoulder bolt on mounting plate and pivot lamp-house clear of projector. Remove three screws from front nose section on lamphouse. Loosen screw in lower left hand corner and swing nose section away.

b. Remove upper wrap from lamphouse by removing four screws.

WARNING

DO NOT VIEW BARE LAMP AND DO NOT EXERT BENDING PRESSURE ON LAMP WHEN REMOVING.

c. Loosen set screw in anode clamp and remove anode clamp and cable from anode end of lamp.

d. Place installation/removal tool over lamp and secure anode end with orange cap and collar. Tighten set screw in collar with 1/8 inch Allen wrench.

e. Loosen set screw in cathode holder using 3/32 Allen wrench tool, and pull installation/removal tool (containing lamp) out of lamphouse.

f. Unscrew and remove lamp adapter from cathode end of lamp.

g. Place orange cap over cathode end of lamp and lamp installation/removal tool, and secure in place with washer, cap restraining bar and wing nut. Return to Optical Radiation Corporation for replacement.

h. Insert new bulb as described in Section 2.

X-4000 Xenon Bulb

a. Loosen shoulder bolt on mounting plate and pivot lamphouse clear of projector. Remove three screws from front nose section on lamphouse. Loosen screw in lower left hand corner and swing nose section away.

b. Remove upper wrap from lamphouse by removing four screws.

WARNING

THE LAMP IS UNDER EXTREME INTERNAL PRESSURE. WEAR PROPER PROTECTIVE CLOTHING BEFORE REMOVING LAMP FROM LAMPHOUSE. FACE MASK, GLOVES AND HEAVY COAT SHOULD BE WORN.

c. Loosen set screw in anode clamp and remove anode clamp from anode end of lamp.

d. While supporting end of lamp with hand, loosen set screw in cathode holder using 3/32 Allen wrench tool.

e. Carefully remove lamp from lamphouse and install plastic wrap around bulb. Return to Optical Radiation Corporation.

f. Insert new bulb as described in Section 2.

5-7 TROUBLE SHOOTING

Whenever lamphouse or power supply fails to operate properly, consult schematic diagrams, figure 5-1 and figure 5-2, as a guide in determining the possible trouble.

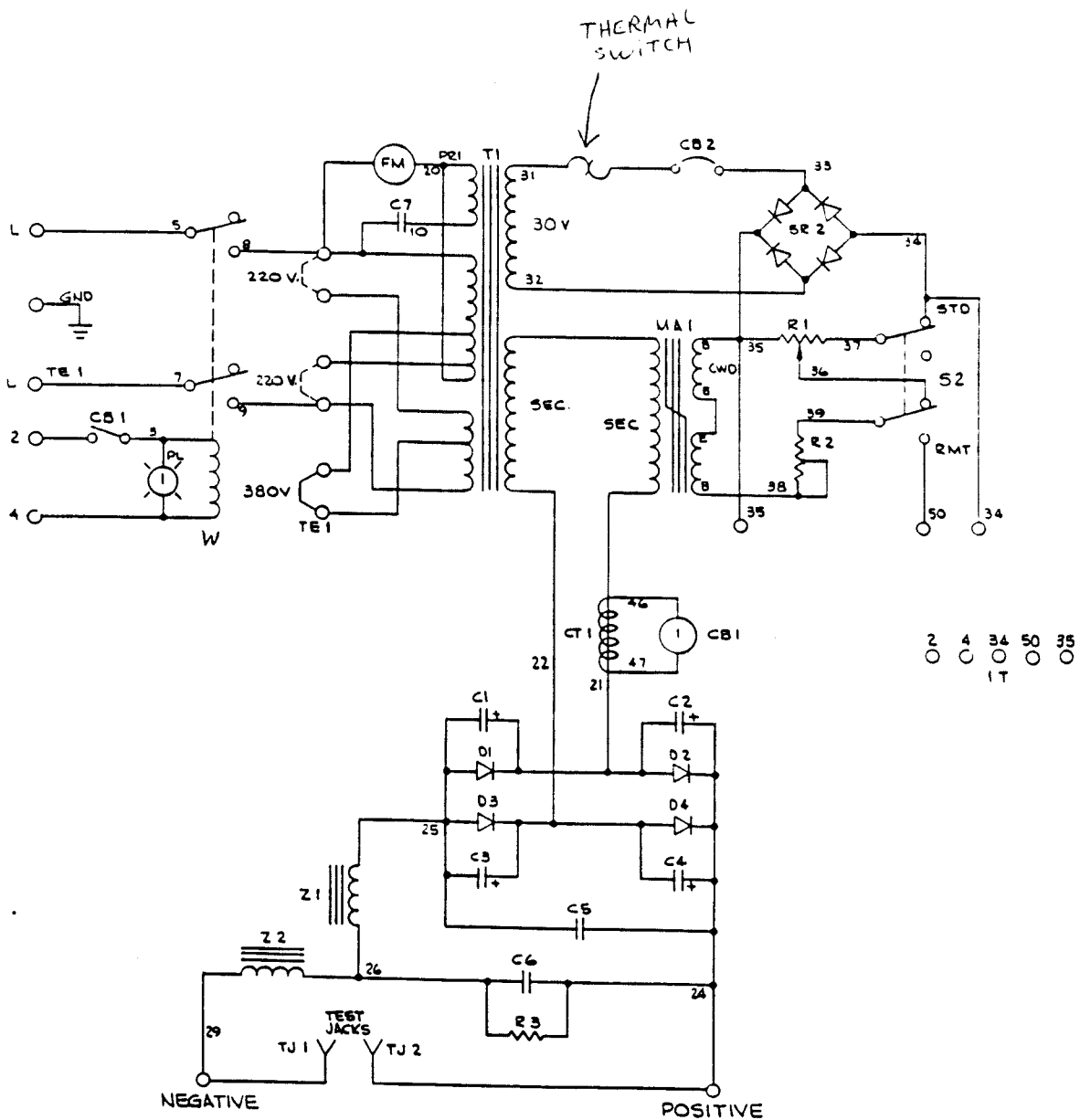

Figure 5-1. Model RPS-X40/30 Power Supply, Schematic Diagram

PARTS LIST

MODEL RPS-X40/30 POWER SUPPLY

Dia. Mkgs.	Factory Part No.	Description	Quantity
CB1	011 914	CIRCUIT BREAKER, single pole 5 ampere 250 volt	1
CB2	011 972	CIRCUIT BREAKER, single pole 10 ampere	1
C6	031 668	CAPACITOR, 4000 UF 100 volt dc	8
C7	025 315	CAPACITOR, 30 UF 440 volt	2
CT1	036 208	TRANSFORMER, current 100/5	1
FM	032 603	MOTOR, fan (consisting of)	1
	*024 601	. BEARING	2
	032 614	BLADE, fan	1
PL1	027 626	LAMP ASSEMBLY, pilot (consisting of)	1
	027 628	. LENS, red	1
	027 629	. BULB, slide base 120 volt	1
	027 631	. HOUSING	1
R1	030 653	RHEOSTAT, 150 watt 15 ohm	1
	019 627	KNOB, rheostat	1
R	030 627	RESISTOR, 2 ohm 100 watt	1
R3	030 094	RESISTOR, 300 ohm 50 watt	1
S2	011 611	SWITCH, toggle DPDT	1
SR1	021 479	RECTIFIER, main (consisting of)	1
C5	031 683	. CAPACITOR, 0.5 mfd 200 volt dc	1
C1-4	031 689	. CAPACITOR	4
	037 305	. DIODE, 66-9390 straight polarity	2
	037 306	. DIODE, 66-9391 reverse polarity	2
SR2	037 601	RECTIFIER, control	1
TE1	026 479	TERMINAL BOARD ASSEMBLY, primary (consisting of)	1
	010 910	. WASHER, flat S.A.E. 3/8"	2
	010 913	. WASHER, flat - brass 3/16"	6
	010 915	. WASHER, flat - brass 1/4"	2
	026 478	. BOARD, mtg - components	1
	026 631	. INSULATION	6
	038 618	. LINK, jumper - brass	2
1T	038 839	. TERMINAL BLOCK, 5 pole	1
	038 887	. SCREW, w/hex hd - brass 10-32 x 1-3/8"	6
	038 888	. SCREW, w/hex hd - brass 1/4-20 x 1-1/2"	2
	038 937	. STUD, brass 3/8-16 x 2"	2
	601 835	. NUT, hex - brass 10-32	18
	601 836	. NUT, hex - brass 1/4-20	6
	601 838	. NUT, hex - brass 3/8-16	6
	602 221	. WASHER, lock - internal tooth 3/8"	2
TJ1	039 654	POST, binding - black (terminal)	1
TJ2	039 655	POST, binding - red (terminal)	1
T1	026 496	TRANSFORMER & AMPLIFIER ASSEMBLY (consisting of)	1
	**026 497	. CORE, transformer & amplifier	1
	**026 493	. COIL, primary	1
	**026 494	. COIL, secondary	1
	**026 495	. COIL, control	2
W	034 740	CONTACTOR (consisting of)	1
	033 050	. COIL	1
	*034 753	. KIT, contact points	1
Z1,2	026 476	STABILIZER	2
	010 853	SCREW, No. 2 slot hd.	2
	010 854	NUT, speed	2
	010 855	RETAINER, screw	2
	019 073	WINDTUNNEL	1
	026 486	BASE	1
	026 498	STRIP, mtg - rectifier	1
	026 499	INSULATOR, bracket mtg capacitor	2
	026 500	ANGLE, glastic mtg capacitor	2
	026 501	BRACKET, mtg capacitor	2
	026 502	BUS BAR, capacitor	2
	026 503	BUS BAR, capacitor	1
	026 504	PANEL, rear	1
	026 507	WRAPPER	1
	026 553	PANEL, front	1
	601 157	BLANK, snap in 1/2"	1
	601 165	BLANK, button plug 1"	2
	602 166	BLANK, button plug 1-7/16"	1

* Recommended Spare Parts.

** Replace at Factory or Authorized Service Station.

BE SURE TO PROVIDE STOCK, MODEL AND SERIAL NUMBERS WHEN ORDERING REPLACEMENT PARTS.

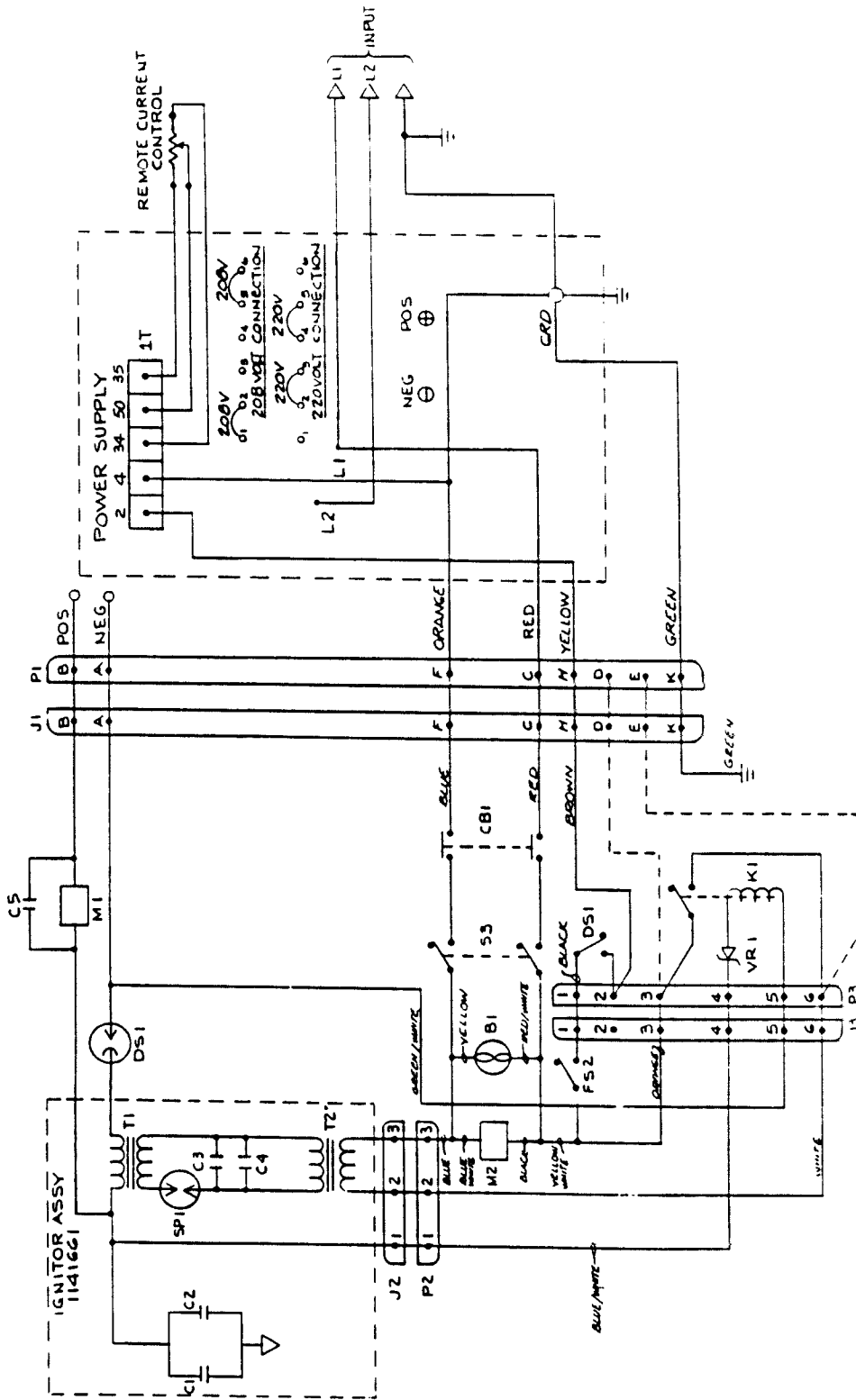
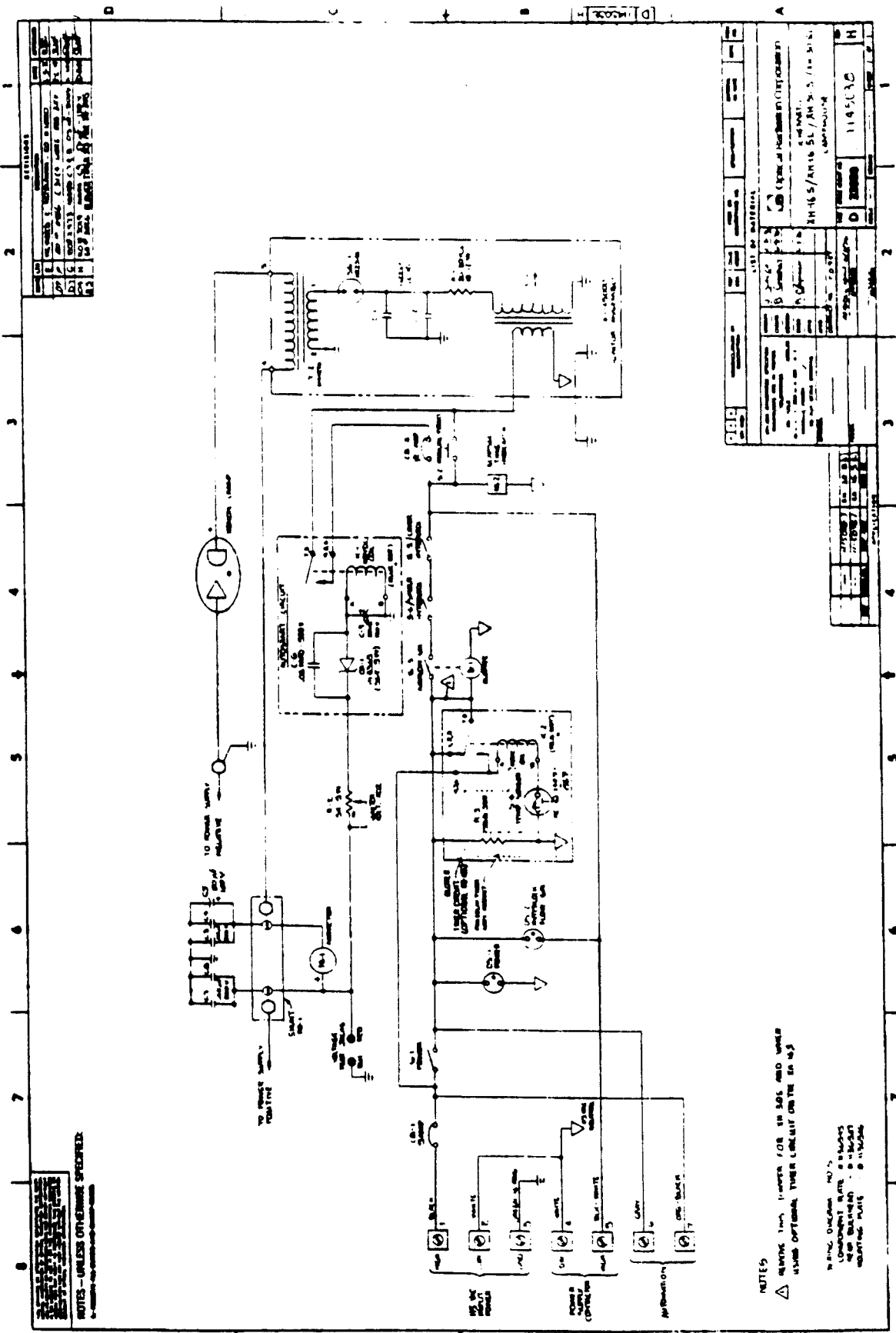

Figure 5-2. Model 3000 Lamphouse, Schematic Diagram



REVISIONS	
1	ASSEMBLY
2	REVISION
3	REVISION
4	REVISION
5	REVISION
6	REVISION
7	REVISION
8	REVISION

LIST OF MATERIALS			
Q1	Diode	1N4001	1
Q2	Diode	1N4001	1
Q3	Diode	1N4001	1
Q4	Diode	1N4001	1
Q5	Diode	1N4001	1
Q6	Diode	1N4001	1
Q7	Diode	1N4001	1
Q8	Diode	1N4001	1
Q9	Diode	1N4001	1
Q10	Diode	1N4001	1
Q11	Diode	1N4001	1
Q12	Diode	1N4001	1
Q13	Diode	1N4001	1
Q14	Diode	1N4001	1
Q15	Diode	1N4001	1
Q16	Diode	1N4001	1
Q17	Diode	1N4001	1
Q18	Diode	1N4001	1
Q19	Diode	1N4001	1
Q20	Diode	1N4001	1
Q21	Diode	1N4001	1
Q22	Diode	1N4001	1
Q23	Diode	1N4001	1
Q24	Diode	1N4001	1
Q25	Diode	1N4001	1
Q26	Diode	1N4001	1
Q27	Diode	1N4001	1
Q28	Diode	1N4001	1
Q29	Diode	1N4001	1
Q30	Diode	1N4001	1
Q31	Diode	1N4001	1
Q32	Diode	1N4001	1
Q33	Diode	1N4001	1
Q34	Diode	1N4001	1
Q35	Diode	1N4001	1
Q36	Diode	1N4001	1
Q37	Diode	1N4001	1
Q38	Diode	1N4001	1
Q39	Diode	1N4001	1
Q40	Diode	1N4001	1
Q41	Diode	1N4001	1
Q42	Diode	1N4001	1
Q43	Diode	1N4001	1
Q44	Diode	1N4001	1
Q45	Diode	1N4001	1
Q46	Diode	1N4001	1
Q47	Diode	1N4001	1
Q48	Diode	1N4001	1
Q49	Diode	1N4001	1
Q50	Diode	1N4001	1
Q51	Diode	1N4001	1
Q52	Diode	1N4001	1
Q53	Diode	1N4001	1
Q54	Diode	1N4001	1
Q55	Diode	1N4001	1
Q56	Diode	1N4001	1
Q57	Diode	1N4001	1
Q58	Diode	1N4001	1
Q59	Diode	1N4001	1
Q60	Diode	1N4001	1
Q61	Diode	1N4001	1
Q62	Diode	1N4001	1
Q63	Diode	1N4001	1
Q64	Diode	1N4001	1
Q65	Diode	1N4001	1
Q66	Diode	1N4001	1
Q67	Diode	1N4001	1
Q68	Diode	1N4001	1
Q69	Diode	1N4001	1
Q70	Diode	1N4001	1
Q71	Diode	1N4001	1
Q72	Diode	1N4001	1
Q73	Diode	1N4001	1
Q74	Diode	1N4001	1
Q75	Diode	1N4001	1
Q76	Diode	1N4001	1
Q77	Diode	1N4001	1
Q78	Diode	1N4001	1
Q79	Diode	1N4001	1
Q80	Diode	1N4001	1
Q81	Diode	1N4001	1
Q82	Diode	1N4001	1
Q83	Diode	1N4001	1
Q84	Diode	1N4001	1
Q85	Diode	1N4001	1
Q86	Diode	1N4001	1
Q87	Diode	1N4001	1
Q88	Diode	1N4001	1
Q89	Diode	1N4001	1
Q90	Diode	1N4001	1
Q91	Diode	1N4001	1
Q92	Diode	1N4001	1
Q93	Diode	1N4001	1
Q94	Diode	1N4001	1
Q95	Diode	1N4001	1
Q96	Diode	1N4001	1
Q97	Diode	1N4001	1
Q98	Diode	1N4001	1
Q99	Diode	1N4001	1
Q100	Diode	1N4001	1

D113198

5-9

7/81

SECTION 6 - LAMP WARRANTY

The lamp warranty on the xenon lamp will not be honored unless the necessary forms are completed.

Upon installation of a new lamp, the xenon lamp warranty card must be filled out and returned to Optical Radiation Corporation. It is mandatory that all information on the card be completed. Shown below is a sample card which was included with delivery.

This card must be filled out and returned within 30 days after installation of the lamp to validate the warranty of your new xenon lamp.

XENON LAMP WARRANTY CARD

USER'S NAME _____ DATE _____

COMPANY _____

STREET ADDRESS _____

CITY _____ STATE _____ ZIP _____

LAMP MODEL NO. _____ SERIAL NO. _____

INSTALLED IN _____ MODEL NO. _____

SERIAL NO. _____

RUNNING TIME METER READING AT TIME OF INSTALLATION _____ HRS.

PURCHASED FROM _____

CITY _____

READ ALL INSTRUCTIONS BEFORE INSTALLING LAMP

If the lamp has failed during the warranty period, the xenon lamp warranty claim form must be filled out and returned to Optical Radiation Corporation along with the defective lamp.

Xenon Bulbs for this lamphouse

Osram XBO 2500W/HS OFR

Christie CXL-25 S

Hanovia CH 2500/HS

ORC XM 2500 HS

Philips CSX 2500 HSC

X-Cel MXL 2500/HSF

SECTION 7 - SPARE PARTS LIST

The following is the list of parts which comprise the Model 3000 ORCON Lamphouse. When ordering replacement parts, please specify complete part number and quantity required. Consult your local dealer or write Optical Radiation Corporation for prices.

REV	DATE	DESCRIPTION	BY	CHKD
A	11/17/60	REVISED TO REFLECT 11/17/60 CHANGES		
B	11/17/60	REVISED TO REFLECT 11/17/60 CHANGES		
C	11/17/60	REVISED TO REFLECT 11/17/60 CHANGES		
D	11/17/60	REVISED TO REFLECT 11/17/60 CHANGES		

1100170 REFLECTOR
 1100169 REFLECTOR HOLDER
 RTV-66 GE SILICONE GLUE

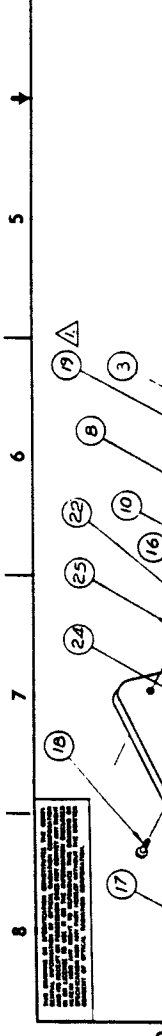

QTY	DESCRIPTION	UNIT	REVISION
1	REFLECTOR		
1	REFLECTOR HOLDER		
1	RTV-66 GE SILICONE GLUE		

QTY	DESCRIPTION	UNIT	REVISION
1	1100170 REFLECTOR		
1	1100169 REFLECTOR HOLDER		
1	RTV-66 GE SILICONE GLUE		
1	1100170 REFLECTOR		
1	1100169 REFLECTOR HOLDER		
1	RTV-66 GE SILICONE GLUE		

QTY	DESCRIPTION	UNIT	REVISION
1	1100170 REFLECTOR		
1	1100169 REFLECTOR HOLDER		
1	RTV-66 GE SILICONE GLUE		
1	1100170 REFLECTOR		
1	1100169 REFLECTOR HOLDER		
1	RTV-66 GE SILICONE GLUE		

NOTES:
 1. ITEM NO. 19 TO HAVE LOCITE APPLIED ON THREADS BEFORE ASSEMBLING INTO ITEM 5.
 2. ITEM NO. 21 TO BE USED WITH I.C. LAMP ONLY P/N 1100270.
 3. NUMBER STAMP P/N 33030-1141604 USING WHITE INK APPROX. WHERE SHOWN. COVER WITH VARNISH.

1100170 REFLECTOR
 1100169 REFLECTOR HOLDER
 RTV-66 GE SILICONE GLUE

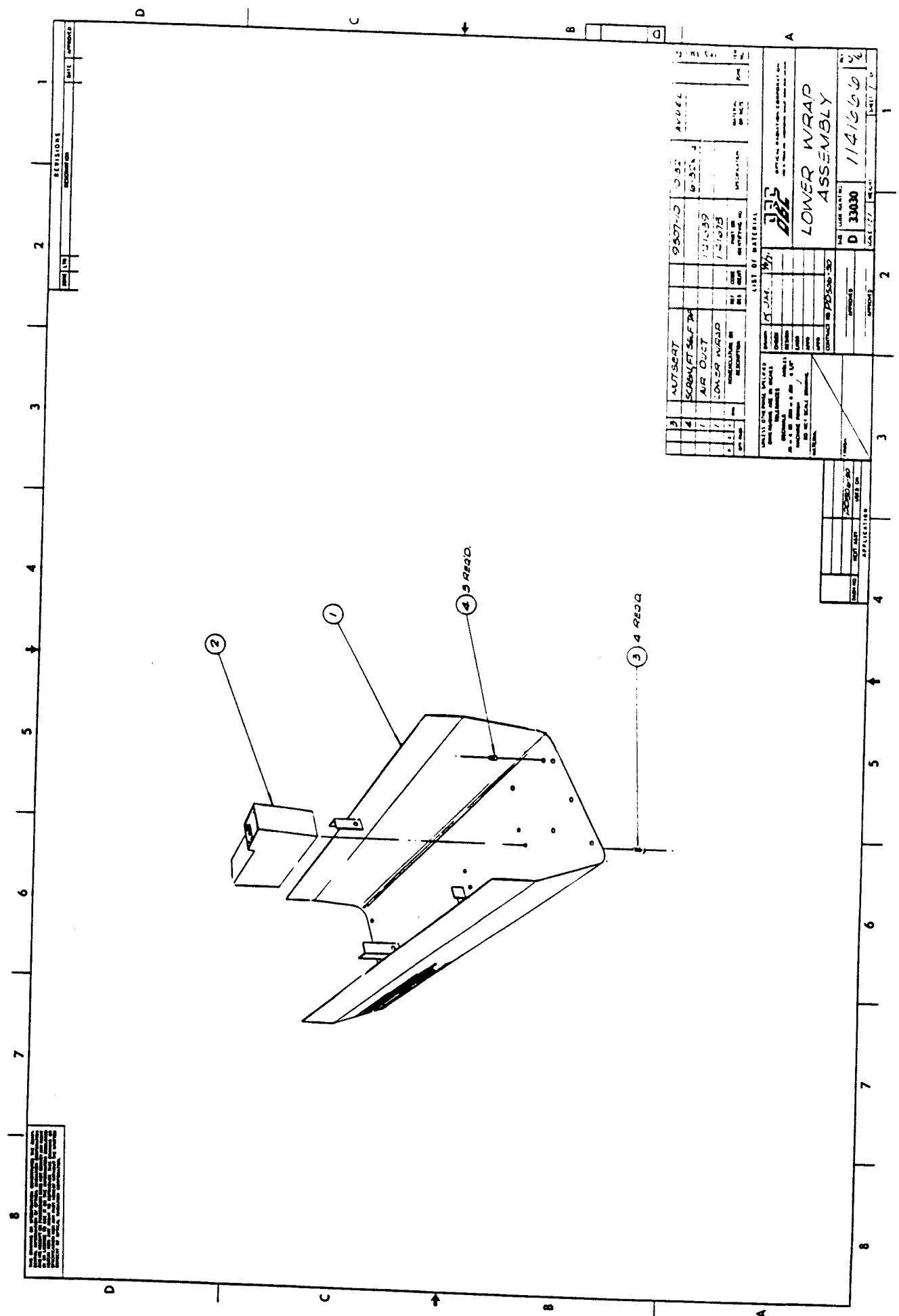

1. THIS DRAWING IS THE PROPERTY OF THE U.S. AIR FORCE. IT IS TO BE KEPT IN CONFIDENTIALITY AND NOT TO BE REPRODUCED OR TRANSMITTED IN ANY FORM OR BY ANY MEANS, ELECTRONIC OR MECHANICAL, INCLUDING PHOTOCOPYING, RECORDING, OR BY ANY INFORMATION STORAGE AND RETRIEVAL SYSTEM, WITHOUT PERMISSION IN WRITING FROM THE U.S. AIR FORCE.

REV	DATE	DESCRIPTION
1		
2		
3		
4		
5		
6		
7		
8		

QTY	DESCRIPTION	UNIT	AVAIL	DATE	BY
1	9507-10	0.52			
1	6.35				
1	7.14.39				
1	7.21.75				

QTY	DESCRIPTION	UNIT	AVAIL	DATE	BY
1	9507-10	0.52			
1	6.35				
1	7.14.39				
1	7.21.75				

QTY	DESCRIPTION	UNIT	AVAIL	DATE	BY
1	9507-10	0.52			
1	6.35				
1	7.14.39				
1	7.21.75				

QTY	DESCRIPTION	UNIT	AVAIL	DATE	BY
1	9507-10	0.52			
1	6.35				
1	7.14.39				
1	7.21.75				

QTY	DESCRIPTION	UNIT	AVAIL	DATE	BY
1	9507-10	0.52			
1	6.35				
1	7.14.39				
1	7.21.75				

QTY	DESCRIPTION	UNIT	AVAIL	DATE	BY
1	9507-10	0.52			
1	6.35				
1	7.14.39				
1	7.21.75				

QTY	DESCRIPTION	UNIT	AVAIL	DATE	BY
1	9507-10	0.52			
1	6.35				
1	7.14.39				
1	7.21.75				

QTY	DESCRIPTION	UNIT	AVAIL	DATE	BY
1	9507-10	0.52			
1	6.35				
1	7.14.39				
1	7.21.75				

QTY	DESCRIPTION	UNIT	AVAIL	DATE	BY
1	9507-10	0.52			
1	6.35				
1	7.14.39				
1	7.21.75				

QTY	DESCRIPTION	UNIT	AVAIL	DATE	BY
1	9507-10	0.52			
1	6.35				
1	7.14.39				
1	7.21.75				

QTY	DESCRIPTION	UNIT	AVAIL	DATE	BY
1	9507-10	0.52			
1	6.35				
1	7.14.39				
1	7.21.75				

QTY	DESCRIPTION	UNIT	AVAIL	DATE	BY
1	9507-10	0.52			
1	6.35				
1	7.14.39				
1	7.21.75				

QTY	DESCRIPTION	UNIT	AVAIL	DATE	BY
1	9507-10	0.52			
1	6.35				
1	7.14.39				
1	7.21.75				

QTY	DESCRIPTION	UNIT	AVAIL	DATE	BY
1	9507-10	0.52			
1	6.35				
1	7.14.39				
1	7.21.75				

QTY	DESCRIPTION	UNIT	AVAIL	DATE	BY
1	9507-10	0.52			
1	6.35				
1	7.14.39				
1	7.21.75				

QTY	DESCRIPTION	UNIT	AVAIL	DATE	BY
1	9507-10	0.52			
1	6.35				
1	7.14.39				
1	7.21.75				

QTY	DESCRIPTION	UNIT	AVAIL	DATE	BY
1	9507-10	0.52			
1	6.35				
1	7.14.39				
1	7.21.75				

QTY	DESCRIPTION	UNIT	AVAIL	DATE	BY
1	9507-10	0.52			
1	6.35				
1	7.14.39				
1	7.21.75				

QTY	DESCRIPTION	UNIT	AVAIL	DATE	BY
1	9507-10	0.52			
1	6.35				
1	7.14.39				
1	7.21.75				

QTY	DESCRIPTION	UNIT	AVAIL	DATE	BY
1	9507-10	0.52			
1	6.35				
1	7.14.39				
1	7.21.75				

QTY	DESCRIPTION	UNIT	AVAIL	DATE	BY
1	9507-10	0.52			
1	6.35				
1	7.14.39				
1	7.21.75				

QTY	DESCRIPTION	UNIT	AVAIL	DATE	BY
1	9507-10	0.52			
1	6.35				
1	7.14.39				
1	7.21.75				

QTY	DESCRIPTION	UNIT	AVAIL	DATE	BY
1	9507-10	0.52			
1	6.35				
1	7.14.39				
1	7.21.75				

QTY	DESCRIPTION	UNIT	AVAIL	DATE	BY
1	9507-10	0.52			
1	6.35				
1	7.14.39				
1	7.21.75				

QTY	DESCRIPTION	UNIT	AVAIL	DATE	BY
1	9507-10	0.52			
1	6.35				
1	7.14.39				
1	7.21.75				

QTY	DESCRIPTION	UNIT	AVAIL	DATE	BY
1	9507-10	0.52			
1	6.35				
1	7.14.39				
1	7.21.75				

QTY	DESCRIPTION	UNIT	AVAIL	DATE	BY
1	9507-10	0.52			
1	6.35				
1	7.14.39				
1	7.21.75				

QTY	DESCRIPTION	UNIT	AVAIL	DATE	BY
1	9507-10	0.52			
1	6.35				
1	7.14.39				
1	7.21.75				

QTY	DESCRIPTION	UNIT	AVAIL	DATE	BY
1	9507-10	0.52			
1	6.35				
1	7.14.39				
1	7.21.75				

QTY	DESCRIPTION	UNIT	AVAIL	DATE	BY
1	9507-10	0.52			
1	6.35				
1	7.14.39				
1	7.21.75				

QTY	DESCRIPTION	UNIT	AVAIL	DATE	BY
1	9507-10	0.52			
1	6.35				
1	7.14.39				
1	7.21.75				

QTY	DESCRIPTION	UNIT	AVAIL	DATE	BY
1	9507-10	0.52			
1	6.35				
1	7.14.39				
1	7.21.75				

QTY	DESCRIPTION	UNIT	AVAIL	DATE	BY
1	9507-10	0.52			
1	6.35				
1	7.14.39				
1	7.21.75				

QTY	DESCRIPTION	UNIT	AVAIL	DATE	BY
1	9507-10	0.52			
1	6.35				
1	7.14.39				
1	7.21.75				

QTY	DESCRIPTION	UNIT	AVAIL	DATE	BY
1	9507-10	0.52			
1	6.35				
1	7.14.39				
1	7.21.75				

QTY	DESCRIPTION	UNIT	AVAIL	DATE	BY
1	9507-10	0.52			
1	6.35				
1	7.14.39				
1	7.21.75				

QTY	DESCRIPTION	UNIT	AVAIL	DATE	BY
1	9507-10	0.52			
1	6.35				
1	7.14.39				
1	7.21.75				

QTY	DESCRIPTION	UNIT	AVAIL	DATE	BY
1	9507-10	0.52			
1	6.35				
1	7.14.39				
1	7.21.75				

QTY	DESCRIPTION	UNIT	AVAIL	DATE	BY
1	9507-10	0.52			
1	6.35				
1	7.14.39				
1	7.21.75				

QTY	DESCRIPTION	UNIT	AVAIL	DATE	BY
1	9507-10	0.52			
1	6.35				
1	7.14.39				
1	7.21.75				

QTY	DESCRIPTION	UNIT	AVAIL	DATE	BY
1	9507-10	0.52			
1	6.35				
1	7.14.39				
1	7.21.75				

QTY	DESCRIPTION	UNIT	AVAIL	DATE	BY
1	9507-10	0.52			
1	6.35				
1	7.14.39				
1	7.21.75				

QTY	DESCRIPTION	UNIT	AVAIL	DATE	BY
1	9507-10	0.52			
1	6.35				
1	7.14.39				
1	7.21.75				

QTY	DESCRIPTION	UNIT	AVAIL	DATE	BY
1	9507-10	0.52			
1	6.35				
1	7.14.39				
1	7.21.75				

||
||
||

1
 2
 3
 4
 5
 6
 7
 8

THE INFORMATION CONTAINED HEREIN IS UNCLASSIFIED EXCEPT WHERE SHOWN OTHERWISE. IT IS THE PROPERTY OF THE U.S. GOVERNMENT AND IS LOANED TO YOUR AGENCY; IT AND ITS CONTENTS ARE NOT TO BE DISTRIBUTED OUTSIDE YOUR AGENCY.

REVISIONS
 DATE APPROVED BY DATE OF APPROVAL
 1/25/58

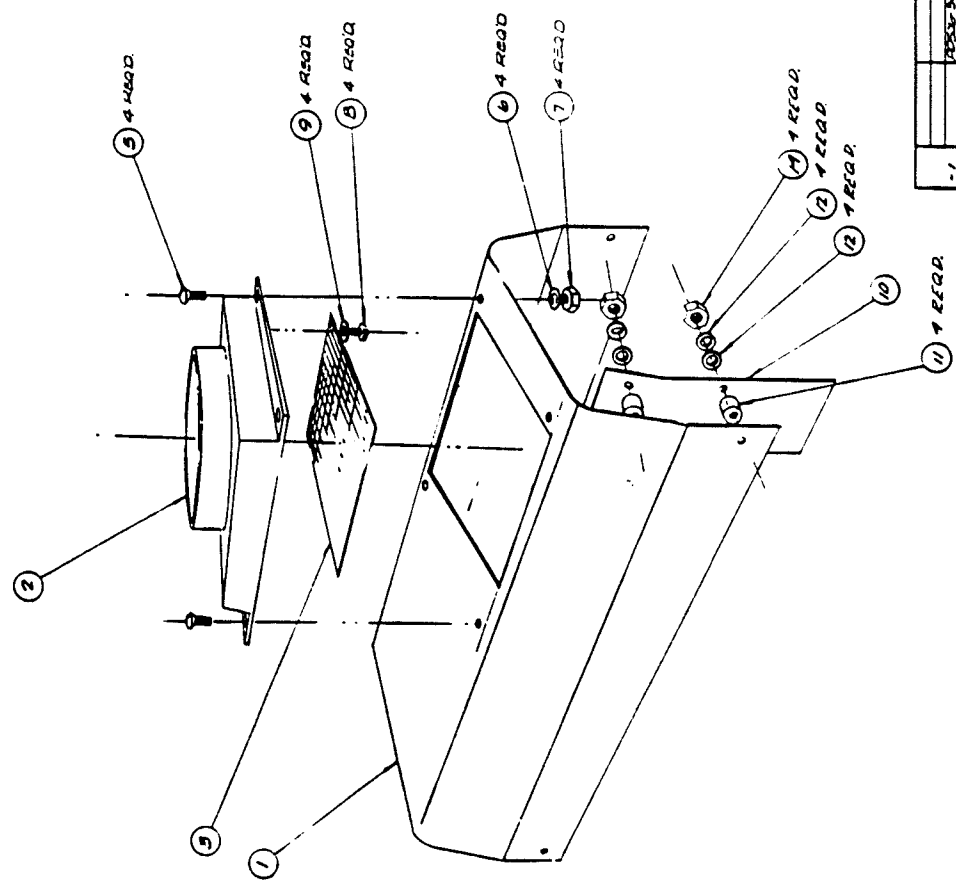

QTY	DESCRIPTION	PART NO.	QTY	DESCRIPTION	PART NO.	QTY	DESCRIPTION	PART NO.
1	NUT	1120971	1	SCREEN	1120971	1	SCREEN	1120971
1	WASHER, LOCK	1120971	1	WASHER, STAR	1120971	1	WASHER, STAR	1120971
1	WASHER, FLAT	1120971	1	WASHER, STAR	1120971	1	WASHER, STAR	1120971
1	SPACER	1120971	1	WASHER, STAR	1120971	1	WASHER, STAR	1120971
1	WASHER, FLAT	1120971	1	WASHER, STAR	1120971	1	WASHER, STAR	1120971
1	NEAT SOLDER	1120971	1	WASHER, STAR	1120971	1	WASHER, STAR	1120971
1	SCREEN, PAIN NO	1120971	1	WASHER, STAR	1120971	1	WASHER, STAR	1120971
1	NUT, HEX	1120971	1	WASHER, STAR	1120971	1	WASHER, STAR	1120971
1	WASHER, STAR	1120971	1	WASHER, STAR	1120971	1	WASHER, STAR	1120971
1	SCREEN, J.A. NO	1120971	1	WASHER, STAR	1120971	1	WASHER, STAR	1120971
1	SCREEN	1120971	1	WASHER, STAR	1120971	1	WASHER, STAR	1120971
1	FLANGE, ST. SS	1120971	1	WASHER, STAR	1120971	1	WASHER, STAR	1120971
1	LOOSE W. RAD	1120971	1	WASHER, STAR	1120971	1	WASHER, STAR	1120971

LIST OF MATERIAL
 UPPER WRAP ASSEMBLY
 PART NO. 33030
 DATE 1/25/58
 DRAWN BY [Name]
 CHECKED BY [Name]
 APPROVED BY [Name]

1
 2
 3
 4
 5
 6
 7
 8

REVISIONS
 DATE APPROVED BY DATE OF APPROVAL
 1/25/58

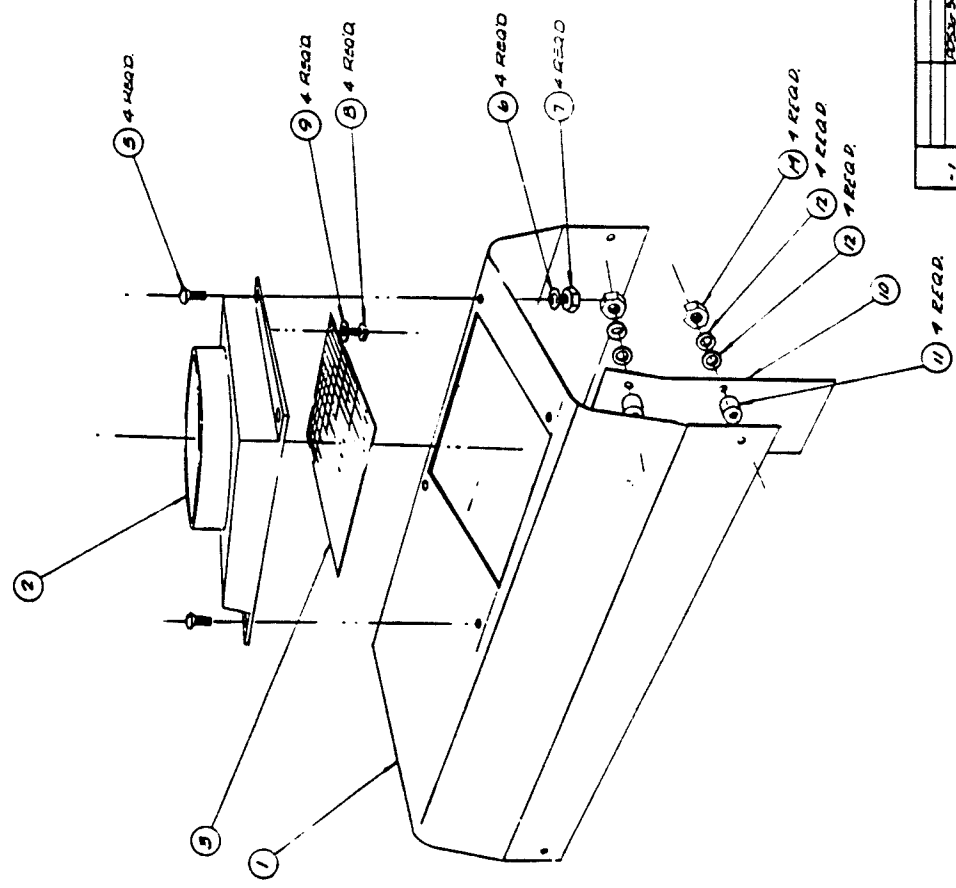

QTY	DESCRIPTION	PART NO.	QTY	DESCRIPTION	PART NO.	QTY	DESCRIPTION	PART NO.
1	NUT	1120971	1	SCREEN	1120971	1	SCREEN	1120971
1	WASHER, LOCK	1120971	1	WASHER, STAR	1120971	1	WASHER, STAR	1120971
1	WASHER, FLAT	1120971	1	WASHER, STAR	1120971	1	WASHER, STAR	1120971
1	SPACER	1120971	1	WASHER, STAR	1120971	1	WASHER, STAR	1120971
1	WASHER, FLAT	1120971	1	WASHER, STAR	1120971	1	WASHER, STAR	1120971
1	NEAT SOLDER	1120971	1	WASHER, STAR	1120971	1	WASHER, STAR	1120971
1	SCREEN, PAIN NO	1120971	1	WASHER, STAR	1120971	1	WASHER, STAR	1120971
1	NUT, HEX	1120971	1	WASHER, STAR	1120971	1	WASHER, STAR	1120971
1	WASHER, STAR	1120971	1	WASHER, STAR	1120971	1	WASHER, STAR	1120971
1	SCREEN, J.A. NO	1120971	1	WASHER, STAR	1120971	1	WASHER, STAR	1120971
1	SCREEN	1120971	1	WASHER, STAR	1120971	1	WASHER, STAR	1120971
1	FLANGE, ST. SS	1120971	1	WASHER, STAR	1120971	1	WASHER, STAR	1120971
1	LOOSE W. RAD	1120971	1	WASHER, STAR	1120971	1	WASHER, STAR	1120971

LIST OF MATERIAL
 UPPER WRAP ASSEMBLY
 PART NO. 33030
 DATE 1/25/58
 DRAWN BY [Name]
 CHECKED BY [Name]
 APPROVED BY [Name]

1 2 3 4 5 6 7 8

REV	DATE	BY	APP	DESCRIPTION
1				ISSUED FOR RECORD

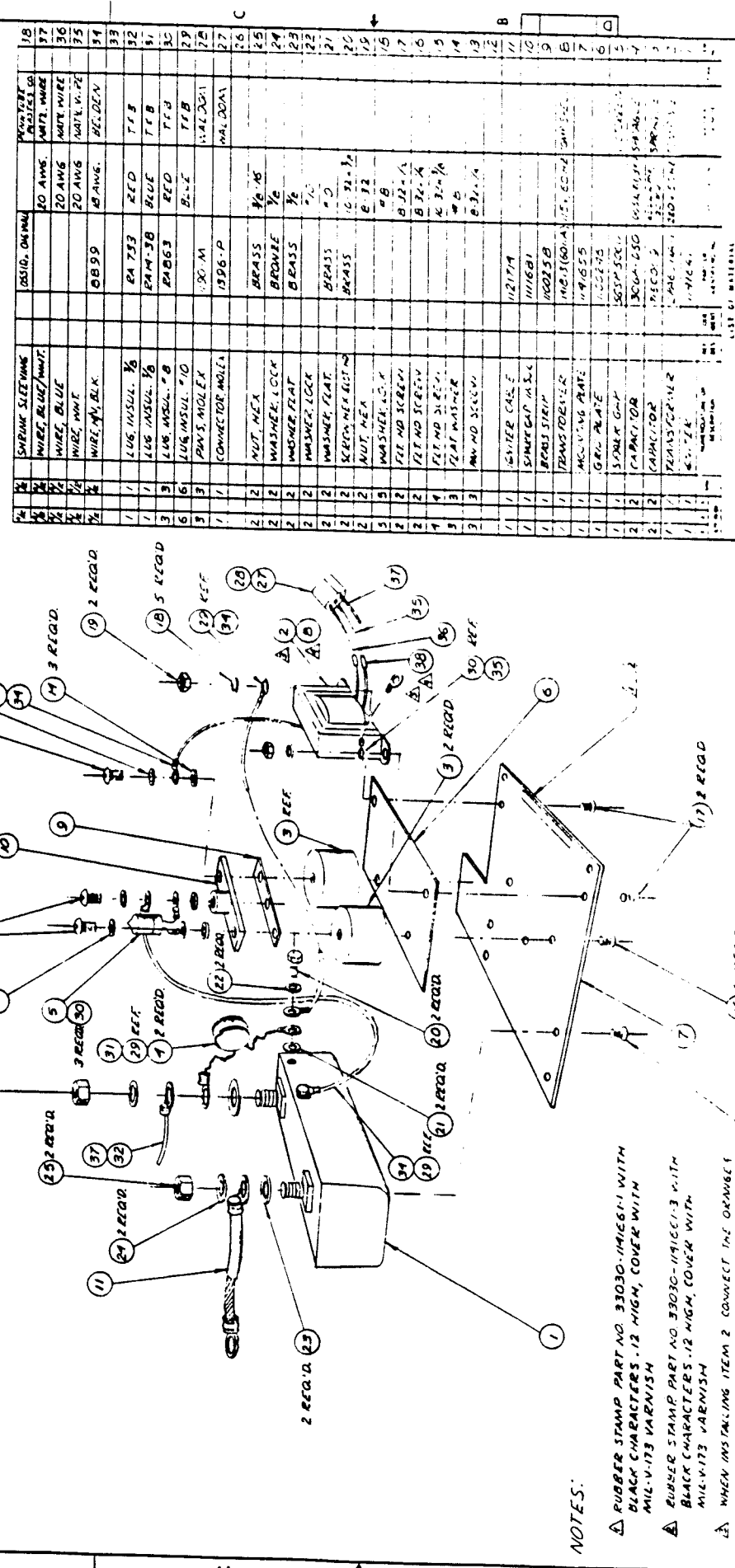

QTY	SYMBOL	DESCRIPTION	UNIT	QTY	SYMBOL	DESCRIPTION	UNIT	QTY	SYMBOL	DESCRIPTION	UNIT	QTY	SYMBOL	DESCRIPTION	UNIT
1	1	SPRING SLEEVE		1	1	LUG INSUL. 3/8		1	1	WASHER, LOCK		1	1	WASHER, LOCK	
1	2	WIRE, BLUE		1	1	LUG INSUL. 3/8		2	2	WASHER, LOCK		2	2	WASHER, LOCK	
1	3	WIRE, BLUE		3	3	LUG INSUL. #8		2	2	WASHER, LOCK		2	2	WASHER, LOCK	
1	4	WIRE, WHITE		6	6	LUG INSUL. #10		2	2	WASHER, LOCK		2	2	WASHER, LOCK	
1	5	WIRE, W. BLK.		3	3	PLATE, MOLEX		2	2	WASHER, LOCK		2	2	WASHER, LOCK	
1	6			3	3	CONNECTOR MOLEX		2	2	WASHER, LOCK		2	2	WASHER, LOCK	
1	7			1	1	CONTRACTOR MOLEX		2	2	WASHER, LOCK		2	2	WASHER, LOCK	
1	8			2	2	NUT, HEX		2	2	WASHER, LOCK		2	2	WASHER, LOCK	
1	9			2	2	WASHER, LOCK		2	2	WASHER, LOCK		2	2	WASHER, LOCK	
1	10			2	2	WASHER, LOCK		2	2	WASHER, LOCK		2	2	WASHER, LOCK	
1	11			2	2	WASHER, LOCK		2	2	WASHER, LOCK		2	2	WASHER, LOCK	
1	12			2	2	WASHER, LOCK		2	2	WASHER, LOCK		2	2	WASHER, LOCK	
1	13			2	2	WASHER, LOCK		2	2	WASHER, LOCK		2	2	WASHER, LOCK	
1	14			2	2	WASHER, LOCK		2	2	WASHER, LOCK		2	2	WASHER, LOCK	
1	15			2	2	WASHER, LOCK		2	2	WASHER, LOCK		2	2	WASHER, LOCK	
1	16			2	2	WASHER, LOCK		2	2	WASHER, LOCK		2	2	WASHER, LOCK	
1	17			2	2	WASHER, LOCK		2	2	WASHER, LOCK		2	2	WASHER, LOCK	
1	18			2	2	WASHER, LOCK		2	2	WASHER, LOCK		2	2	WASHER, LOCK	
1	19			2	2	WASHER, LOCK		2	2	WASHER, LOCK		2	2	WASHER, LOCK	
1	20			2	2	WASHER, LOCK		2	2	WASHER, LOCK		2	2	WASHER, LOCK	
1	21			2	2	WASHER, LOCK		2	2	WASHER, LOCK		2	2	WASHER, LOCK	
1	22			2	2	WASHER, LOCK		2	2	WASHER, LOCK		2	2	WASHER, LOCK	
1	23			2	2	WASHER, LOCK		2	2	WASHER, LOCK		2	2	WASHER, LOCK	
1	24			2	2	WASHER, LOCK		2	2	WASHER, LOCK		2	2	WASHER, LOCK	
1	25			2	2	WASHER, LOCK		2	2	WASHER, LOCK		2	2	WASHER, LOCK	
1	26			2	2	WASHER, LOCK		2	2	WASHER, LOCK		2	2	WASHER, LOCK	
1	27			2	2	WASHER, LOCK		2	2	WASHER, LOCK		2	2	WASHER, LOCK	
1	28			2	2	WASHER, LOCK		2	2	WASHER, LOCK		2	2	WASHER, LOCK	
1	29			2	2	WASHER, LOCK		2	2	WASHER, LOCK		2	2	WASHER, LOCK	
1	30			2	2	WASHER, LOCK		2	2	WASHER, LOCK		2	2	WASHER, LOCK	
1	31			2	2	WASHER, LOCK		2	2	WASHER, LOCK		2	2	WASHER, LOCK	
1	32			2	2	WASHER, LOCK		2	2	WASHER, LOCK		2	2	WASHER, LOCK	
1	33			2	2	WASHER, LOCK		2	2	WASHER, LOCK		2	2	WASHER, LOCK	
1	34			2	2	WASHER, LOCK		2	2	WASHER, LOCK		2	2	WASHER, LOCK	
1	35			2	2	WASHER, LOCK		2	2	WASHER, LOCK		2	2	WASHER, LOCK	
1	36			2	2	WASHER, LOCK		2	2	WASHER, LOCK		2	2	WASHER, LOCK	
1	37			2	2	WASHER, LOCK		2	2	WASHER, LOCK		2	2	WASHER, LOCK	

- NOTES:
- △ RUBBER STAMP PART NO. 33030-1141681-1 WITH BLACK CHARACTERS .12 HIGH, COVER WITH MIL-V-173 VARNISH
 - △ RUBBER STAMP PART NO. 33030-1141681-3 WITH BLACK CHARACTERS .12 HIGH, COVER WITH MIL-V-173 VARNISH
 - △ WHEN INSTALLING ITEM 2 CONNECT THE ORANGE & RED WIRES OF ITEM 2, CONNECT RED WIRE TO ITEM 35, CONNECT BROWN WIRE TO ITEM 36, COVER ALL CONNECTIONS WITH ITEM 30
 - △ WHEN INSTALLING ITEM 8 CONNECT THE BROWN WIRE TO ITEM 36, CONNECT THE YELLOW WIRE TO ITEM 35, COVER ALL CONNECTIONS WITH ITEM 30

REV	DATE	BY	APP	DESCRIPTION
1				ISSUED FOR RECORD

REV	DATE	BY	APP	DESCRIPTION
1				ISSUED FOR RECORD

1 2 3 4 5 6 7 8

REVISED		DATE	BY
A	ITEM #1 WAS L. CLANG PM	1/11/52	OKC
B	ADD ITEM #3 WAS 1100274	1/11/52	OKC
C	NOTES 1/12		
	ITEM #3 WAS NOT NEX		
	REF. TO 2012		
	REF. TO 2012		

QTY	DESCRIPTION	UNIT	PRICE	TOTAL
1	WASHER FLAT			
1	FLAT HD BOLT			
1	FLAT WASHER			
2	MT SCREWS			
4	MT HEAD SCREW			
2	FLAT HD SCREW			
1	ZUBB			
1	CATCH			
1	GRUVE AN			
1	SHAFT			
1	SPACER			
1	HANDLE			
1	GRUVE - PM			
1	SHUTTER PLATE			
1	SHUTTER PLATE			
1	FRONT BRACKET			

QTY	DESCRIPTION	UNIT	PRICE	TOTAL
1	WASHER FLAT			
1	FLAT HD BOLT			
1	FLAT WASHER			
2	MT SCREWS			
4	MT HEAD SCREW			
2	FLAT HD SCREW			
1	ZUBB			
1	CATCH			
1	GRUVE AN			
1	SHAFT			
1	SPACER			
1	HANDLE			
1	GRUVE - PM			
1	SHUTTER PLATE			
1	SHUTTER PLATE			
1	FRONT BRACKET			

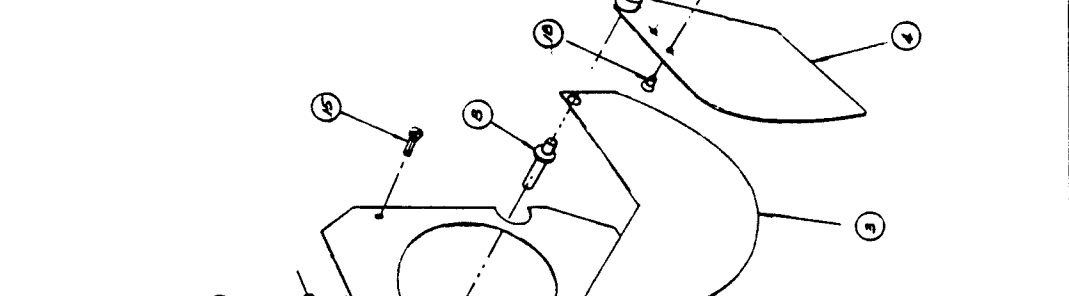

NOTES:
 RUBBER STAMP PART NO. 33030-1140894-1 ASSY WITH
 WHITE CHARACTERS .12 HIGH, COVER WITH MIL-V-113 VARNISH
 SHIM AS REQUIRED

QTY	DESCRIPTION	UNIT	PRICE	TOTAL
1	WASHER FLAT			
1	FLAT HD BOLT			
1	FLAT WASHER			
2	MT SCREWS			
4	MT HEAD SCREW			
2	FLAT HD SCREW			
1	ZUBB			
1	CATCH			
1	GRUVE AN			
1	SHAFT			
1	SPACER			
1	HANDLE			
1	GRUVE - PM			
1	SHUTTER PLATE			
1	SHUTTER PLATE			
1	FRONT BRACKET			

QTY	DESCRIPTION	UNIT	PRICE	TOTAL
1	WASHER FLAT			
1	FLAT HD BOLT			
1	FLAT WASHER			
2	MT SCREWS			
4	MT HEAD SCREW			
2	FLAT HD SCREW			
1	ZUBB			
1	CATCH			
1	GRUVE AN			
1	SHAFT			
1	SPACER			
1	HANDLE			
1	GRUVE - PM			
1	SHUTTER PLATE			
1	SHUTTER PLATE			
1	FRONT BRACKET			

Model M-1000-318000

FRONT BRACKET
 ASSEMBLY

1140894 C

1140894 C

QTY	DESCRIPTION	UNIT	PRICE	TOTAL
1	WASHER FLAT			
1	FLAT HD BOLT			
1	FLAT WASHER			
2	MT SCREWS			
4	MT HEAD SCREW			
2	FLAT HD SCREW			
1	ZUBB			
1	CATCH			
1	GRUVE AN			
1	SHAFT			
1	SPACER			
1	HANDLE			
1	GRUVE - PM			
1	SHUTTER PLATE			
1	SHUTTER PLATE			
1	FRONT BRACKET			

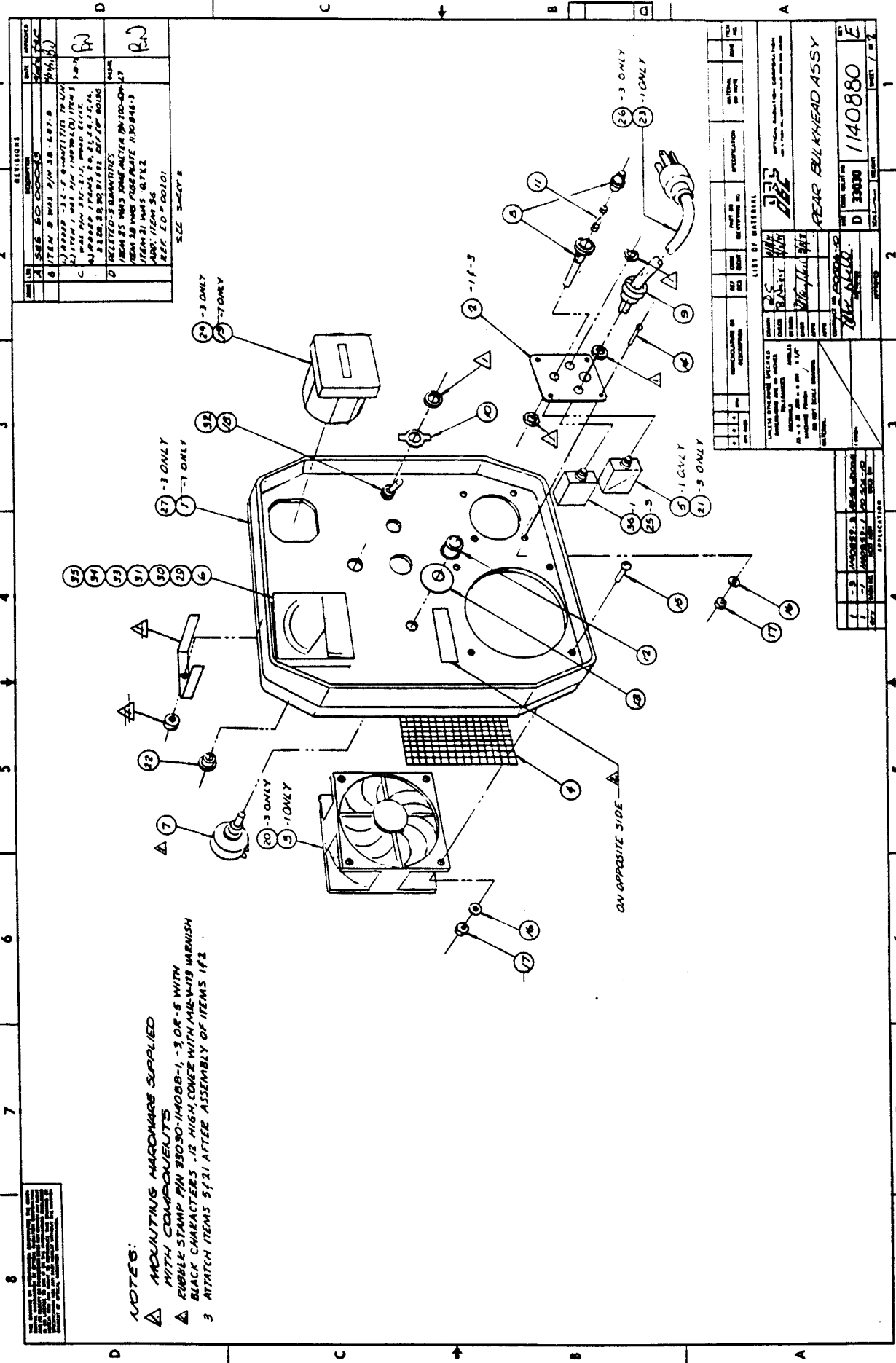

REV	DATE	DESCRIPTION
1	10/1/53	ISSUED FOR PRODUCTION
2	10/1/53	REVISIONS
3	10/1/53	REVISIONS
4	10/1/53	REVISIONS
5	10/1/53	REVISIONS
6	10/1/53	REVISIONS
7	10/1/53	REVISIONS
8	10/1/53	REVISIONS

NOTES:
 ▲ INDUATING MARGWARE SUPPLIED WITH COMPONENTS
 ▲ RUBBER STAMP PIN 330-1408B-1, -3 OR -5 WITH BLACK CHARACTERS 1/2 HIGH COVER WITH MIL-N-118 WARMISH
 3 ATTATCH ITEMS 51, 21 AFTER ASSEMBLY OF ITEMS 1, 2

LIST OF MATERIAL	
NO	DESCRIPTION
1	...
2	...
3	...
4	...
5	...
6	...
7	...
8	...
9	...
10	...
11	...
12	...
13	...
14	...
15	...
16	...
17	...
18	...
19	...
20	...
21	...
22	...
23	...
24	...
25	...
26	...
27	...
28	...
29	...
30	...
31	...
32	...
33	...
34	...
35	...
36	...
37	...
38	...
39	...
40	...
41	...
42	...
43	...
44	...
45	...
46	...
47	...
48	...
49	...
50	...
51	...
52	...
53	...
54	...
55	...

APPLICATIONS	
NO	DESCRIPTION
1	...
2	...
3	...
4	...
5	...
6	...
7	...
8	...
9	...
10	...
11	...
12	...
13	...
14	...
15	...
16	...
17	...
18	...
19	...
20	...
21	...
22	...
23	...
24	...
25	...
26	...
27	...
28	...
29	...
30	...
31	...
32	...
33	...
34	...
35	...
36	...
37	...
38	...
39	...
40	...
41	...
42	...
43	...
44	...
45	...
46	...
47	...
48	...
49	...
50	...
51	...
52	...
53	...
54	...
55	...

REAR BULLHEAD ASSY
 D 33030 1140880
 1/2

Model A7-1111
 S-1111

THIS IS A SUMMARY OF THE MATERIALS LISTED IN THE DRAWING. IT IS NOT TO BE USED AS A PURCHASE ORDER. THE MATERIALS LISTED IN THE DRAWING ARE SUBJECT TO CHANGE WITHOUT NOTICE. THE MATERIALS LISTED IN THE DRAWING ARE SUBJECT TO CHANGE WITHOUT NOTICE.

REV	DATE	DESCRIPTION	BY	CHKD
1	1/28/53	REVISED TO SHOW 1/2" DIA. HOLES IN WASHERS AND LOCKS
2	2/10/53	REVISED TO SHOW 1/4" DIA. HOLES IN WASHERS AND LOCKS

REV	DATE	DESCRIPTION	BY	CHKD
3	3/15/53	REVISED TO SHOW 1/2" DIA. HOLES IN WASHERS AND LOCKS

QTY	DESCRIPTION	QTY	DESCRIPTION	QTY	DESCRIPTION	QTY	DESCRIPTION
1	CIRCUIT BREAKER	1	45-200 P A	1	ETA	1	1 AMP
2	NUT, HEX	1/4 - 20					
2	WASHER, FLAT	3/4					BRASS
2	WASHER, W/ LOCK	3/4					BRASS
1	LUG	42822-1					AMP
4	WASHER, LOCK	NO 4					
4	WASHER, FLAT	NO 4					
4	NUT, HEX	4-42					
1	REAR BULKHEAD	1140701-3					
1	CABLE SCREW, M2	18107					BELDON
1	CIRCUIT BREAKER	45-200 P 5A					ETA
1	CLIP, THE MTR	200 70X 17					25 AMP
1	CABLE	176295					ENGLER
2	FLANGED BRG	40548-3					BELDON
1	CIRCUIT BREAKER	45-200 P					ETA
1	FAN	7550					1/2 AMP
1	SPST SWITCH	41845					4000-400T
1	LOCK WASHER	NO 6					
1	RAIN-HEAD SCREEN	4-32-7116					
1	RAIN-HEAD SCREEN	6-32-7116					
1	DIAL PLATE	5017					OMATE
1	1/4 AMP FUSE	5/31					OMATE
1	SWITCH PLATE	AGC 1/4					BUSS
1	FUSE HOLDER	YD					1/2 AMP
1	AGABLE RESISTOR	SR-8 P 2					4250
1	AMP METER	4AD					BUSS
1	CIRCUIT BREAKER	45-200 P					ETA
1	SCREEN	112972					
1	RISE PLATE	20015					PANASONIC
1	REAR BULKHEAD	1140701-1					

LIST OF MATERIALS

APPROVED BY: *[Signature]*

DATE: 1/28/53

PROJECT: REAR BULKHEAD ASSEMBLY

DRAWING NO: 1140880

REV: E

SCALE: 3/4" = 1"

FIGURE 4-5.
35mm MOUNTING KIT
SWIVEL ASSEMBLY

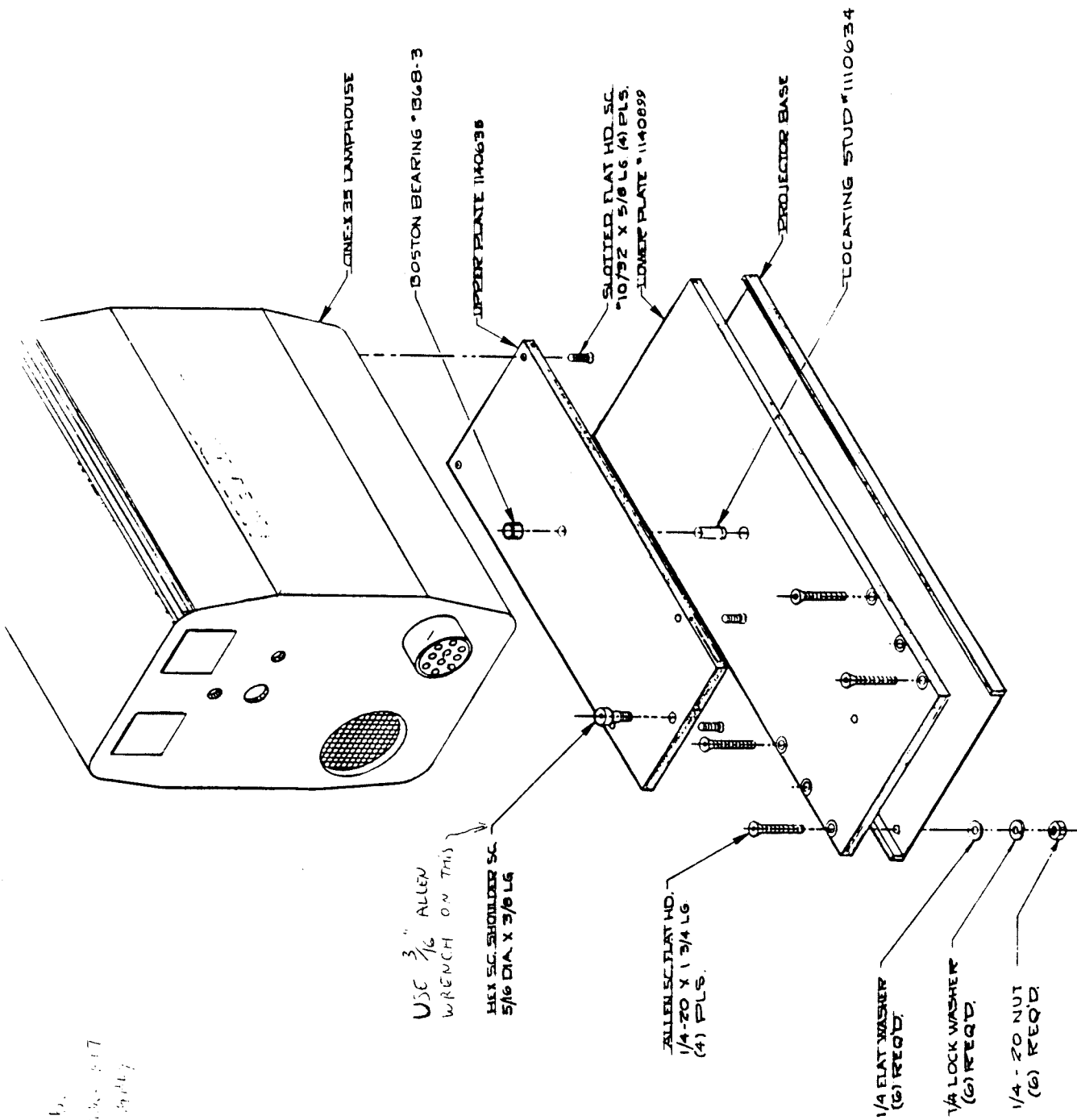

Figure 4-5. 35mm Mounting Kit Swivel Assembly

Notice Regarding Replacing The Original Fan/Blower Motor Assembly In This Lamphouse:

Original Motor Specs:

1/15 HP, 3000 RPM, 115V 60 Hz, 2.4 Amps, Single Speed Fan/Blower Motor

Dayton # 3M043 (W. W. Grainger)

Clockwise rotation facing shaft.

Replacement Motor:

Dayton # 3M548 (W. W. Grainger) Shaft is 1/8 inch longer than original motor's shaft.