

Film-Tech

The information contained in this Adobe Acrobat pdf file is provided at your own risk and good judgment.

These manuals are designed to facilitate the exchange of information related to cinema projection and film handling, with no warranties nor obligations from the authors, for qualified field service engineers.

If you are not a qualified technician, please make no adjustments to anything you may read about in these Adobe manual downloads.

www.film-tech.com

CONSTANT ILLUMINATION DEVICE

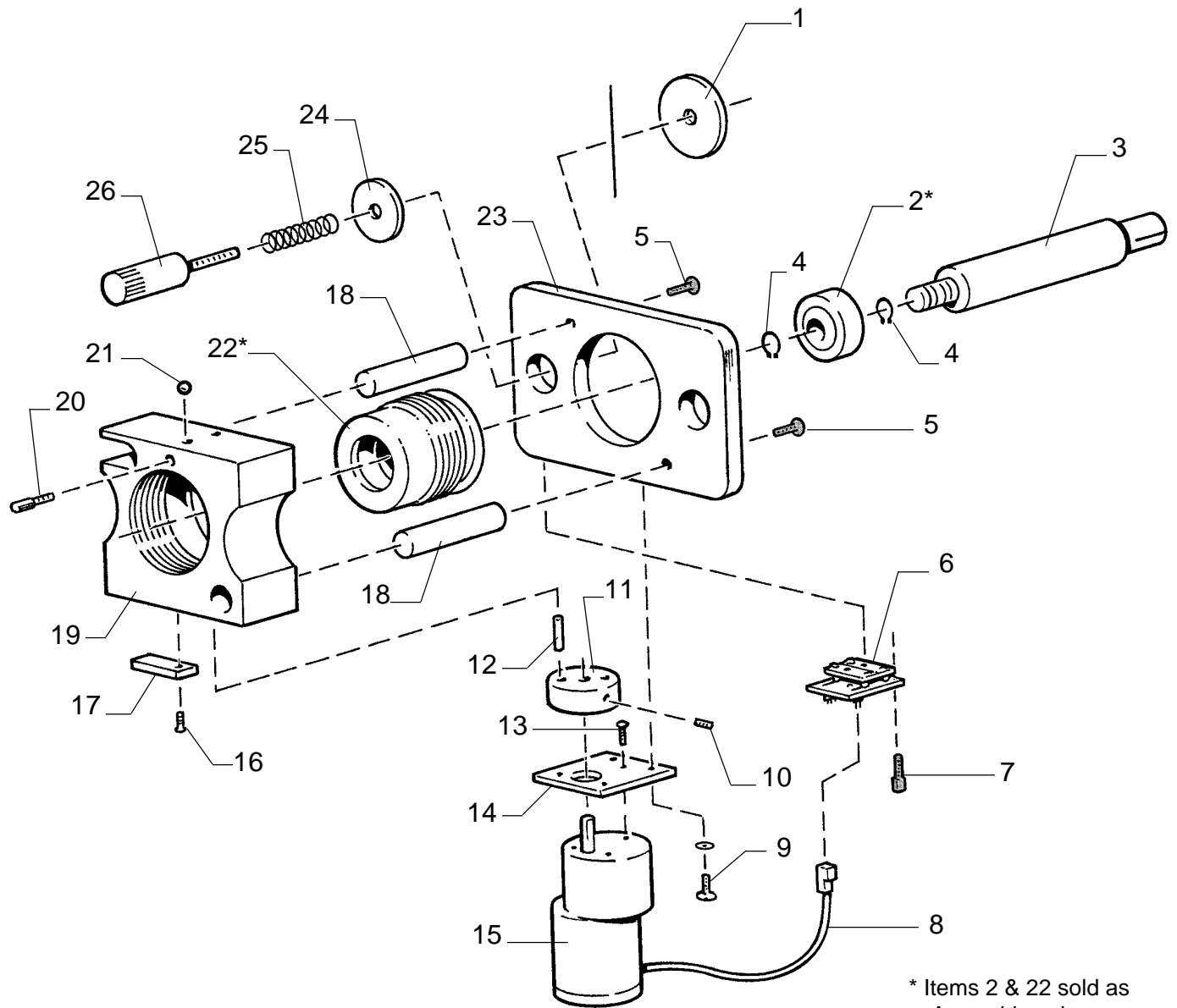

* Items 2 & 22 sold as
Assembly only - see
Parts List

Assembly No. 25248

CONSTANT ILLUMINATION DEVICE

Parts List

<u>Item</u>	<u>Part No.</u>	<u>Description</u>
1	65197	Inner Fender Washer
2	65121	Heim Bearing (Order 65959*)
3	25347	Collet Assembly, 8mm Socket (2, 2.5, 3 kW "HS")
3	25349	Collet Assembly, 8mm Socket (4-7 kW)
3	25353	Collet Assembly, 12mm Socket (2 kW Std.)
3	25355	Collet Assembly, 14mm Socket (3 kW Std.)
3	25356	Collet Assembly, 18mm Socket (5 kW Osram)
4	21-48027	Snap Ring
5	41-51356	Screw, 1/4-20 x 3/4" Flat Socket Head
6	25255	Sensor Board Assembly
7	01304	Screw, 8-32 x 1/4" Bind Head
8	25253	Cable Assembly
9	01311	Screw, 8-32 x 3/8" Bind Head
10	41-51478	Set Screw, 10-32 x 3/16"
11	25257	Cam
12	21-37024	Dowel Pin, 3/16 x 1/2"
13	41-51020	Screw, 4-40 x 3/8" Truss Head
14	25250	Motor Mounting Plate
15	25237	Gear Motor, 1.8 rpm
16	00183	Screw, 6-32 x 1/2" Fillister Head
17	51-61017	Bar Magnet
18	25249	Slide Rod
19	25256	Threaded Carriage
20	65153	Focus Lock Screw
21	65154	Ball, 3/16" Nylon
22	65128	Focus Screw (Order 65959*)
23	25251	Base Plate
24	65150	Outer Fender Washer
25	15010	Compression Spring
26	37985	Thumb Screw
*	65959	Focus Screw & Bearing Assembly (<i>Sold as Assembly only</i>)

NOT SHOWN

24442	Printed Circuit Board, C.I.D. Control
25252	Power Supply Interface Cable
25254	Automation Interface Cable

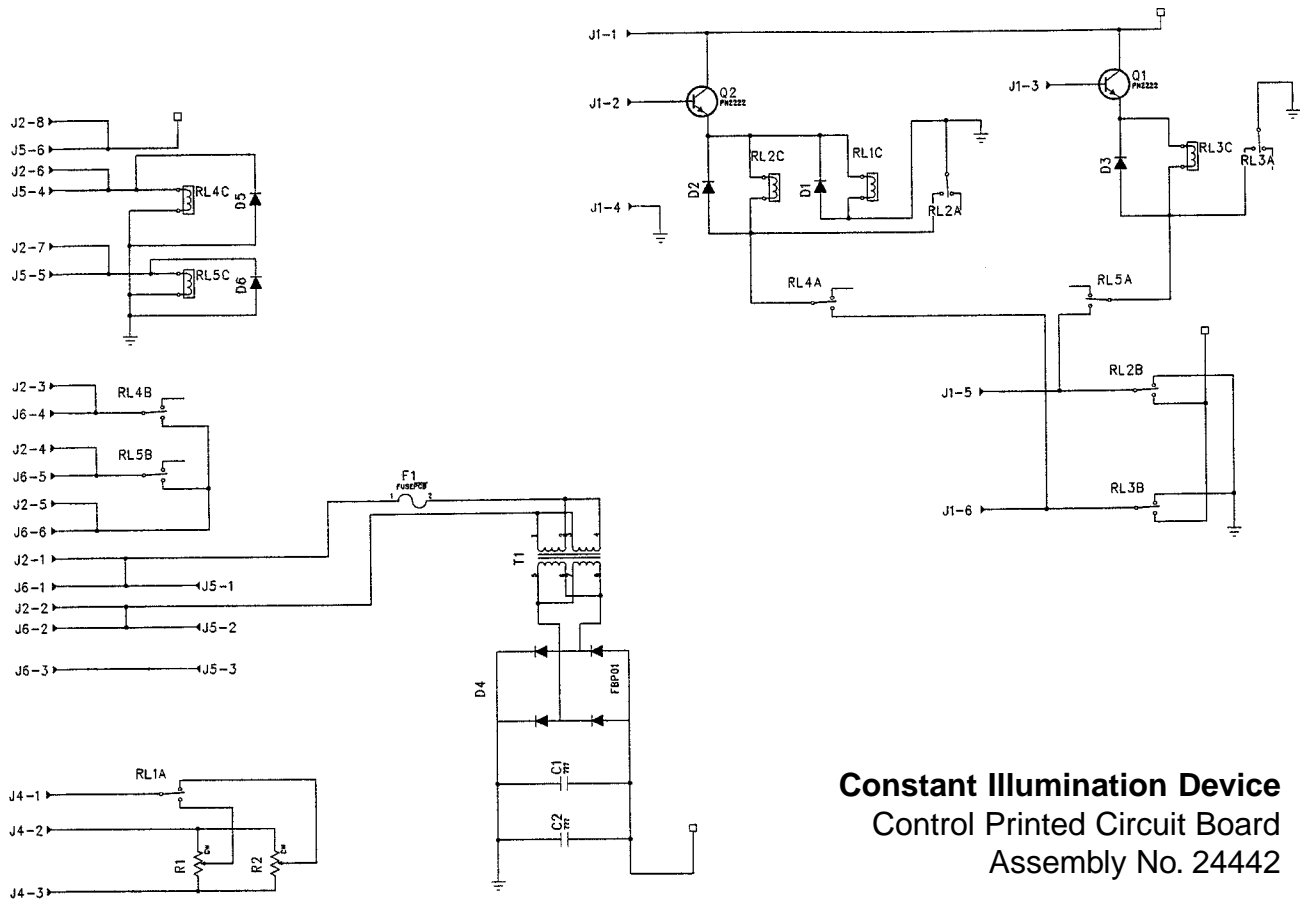

**Constant Illumination Device
Control Printed Circuit Board
Assembly No. 24442**

Description of Circuit Operation

The automation's TURRET output is connected to the J2 receptacle on the 24442 PCB through the automation interface cable 25254. This signal (AC and dry contact) closes the relays to initiate the lens and aperture change cycle through J6, and supply voltage to diode bridge D4. The DC output from the diode bridge energizes the C.I.D. gearmotor (Item 15). Motor torque resets the xenon bulb on its focal plane. A permanent magnet (Item 17), mounted to the threaded carriage (Item 19), actuates the sensor board (Item 6) to interrupt the motor output at J1 at the completion of its cycle.

Power supply current output levels are set at variable resistors R1 and R2, marked SCOPE and FLAT on the PCB. These current levels are set at the installation site for best illumination in the two formats; bulb current must be reduced in the FLAT format to prevent overheating the picture aperture and damaging the print. The J4 receptacle on the PCB connects to the current control DB connector on the power supply through control cable 25252.

