

Film-Tech

The information contained in this Adobe Acrobat pdf file is provided at your own risk and good judgment.

These manuals are designed to facilitate the exchange of information related to cinema projection and film handling, with no warranties nor obligations from the authors, for qualified field service engineers.

If you are not a qualified technician, please make no adjustments to anything you may read about in these Adobe manual downloads

www.film-tech.com

INSTRUCTION MANUAL

ULTRA 80

Xenon Lamphouse

Type 40001, 40002

Rev. 5/99



STRONG INTERNATIONAL

a division of Ballantyne of Omaha, Inc.

4350 McKinley Street

Omaha, Nebraska 68112 USA

Tel 402/453-4444 • Fax 402/453-7238

PREFACE

THE STRONG ULTRA 80 is a reflector type, direct current lamphouse for large format (70mm+) motion picture projection which uses a horizontally mounted xenon bulb as the light source. Type 40001 is designed for use with the XH7000HS xenon bulb, and Type 40002, for the XH10000V(H) bulb. Both type bulbs are manufactured by the Hanovia Division, ORC Lighting Products, Azusa, California. The lamphouse reflector is a metal, deep ellipse type, with a "cold" (dichroic) coating to reduce aperture heat and prolong bulb life. The reflector is designed to operate in a fixed position 34½ to 35 inches from the projection film plane.

USE ONLY THE SPECIAL XENON POWER SUPPLIES manufactured by Strong International. The 40001 lamphouse requires a power supply capable of providing 120-160 DC amperes at 43-49 V.DC. Nominal operating current for a 7000 watt bulb is 150 amperes; **do not exceed 160 amperes**. The xenon power supply used with the 40002 lamphouse must be capable of producing 135-200 DC amperes at 52-58 V.DC. The nominal operating current of a 10,000 watt bulb is 180 amperes; **do not exceed 200 amperes**. The xenon power supply must also include a 120 V.AC lamphouse control circuit.

THE ADJUSTMENT CONTROL to position the xenon bulb in relation to the reflector is located on the rear of the lamphouse, behind the removable cover panel. This control permits horizontal and vertical movement and focus control of the xenon bulb.

A TERMINAL STUD, located near the bulb anode support on the base pan of the lamphouse, is provided as a connecting point for the lamphouse DC (+) lead and the anode lead attached to the xenon bulb.

THE LAMPHOUSE CONTROL PANEL includes a DC ammeter to display the operating current of the lamp. A pushbutton switch above the ammeter changes the reading to indicate the DC voltage at the arc. This capability permits calculation of the lamp power while the lamp is operating (amperes x volts = wattage). Pressing the switch at ignition will also briefly display the "no load" DC voltage.

AN ELAPSED TIME METER indicates the total number of hours the lamp has been in service and provides a means of noting the number of hours each xenon bulb has operated. It is advisable to replace the xenon bulb upon expiration of warranty hours. See the warranty information provided by the manufacturer of the xenon bulb.

THE LAMP BLOWER(S), internally wired in the lamphouse, operate on AC voltage and are required to maintain the seals of the bulb at a safe operating temperature. The top blower is fused at 3 amperes. A second side-mounted blower is used on the Type 40002 to cool the reflector for 10,000 watt operation. The blowers will operate continuously until control voltage is turned off at the xenon power supply.

TWO AIR FLOW SWITCHES, mounted to the exhaust duct and the blower intake, will prevent ignition of the lamp if the top blower is not operating, or the exhaust air flow is inadequate. The eight-inch lamphouse exhaust stack connects to an externally installed exhaust system. The exhaust system must be capable of removing 700 cubic feet per minute (c.f.m.) of free air from the lamphouse, as measured at the lamphouse exhaust outlet.

THE LAMPHOUSE has an interlock switch on the side access door and one under the igniter cover on the top of the lamphouse. Opening the side door or removing the plastic igniter cover will open the AC control circuit and prevent operation of the xenon lamp. The lamphouse door has a viewing port to permit observation of the xenon arc.

THE IGNITER is equipped with an emergency ignition switch, located beneath the plug button on the igniter access panel on the top of the lamphouse.

THE "MODE" rocker type switch on the rear of the lamphouse provides the means of operating the equipment from a remote AUTO system, or when placed in the "MAN." position, from the lamphouse.

THE LAMP "ON - OFF" SWITCH on the lamphouse instrument panel is used for bulb ignition when the MODE switch is in the "MAN." position. For AUTO operation, the LAMP switch remains in the "ON" position.

THE LAMPHOUSE DOUSER is provided to permit shutting off the light to the projector at changeover. The lamp should not be operated for any extended time with the douser closed. The small intense spot of light on the douser plate may cause deterioration of the plate. An Electric Douser Kit, connected to the projector motor, is available as an option. This option automatically closes the douser when the projector motor is switched OFF.

THE ULTRA 80 is *not* designed for use with 35mm projection. The highly intense radiant energy generated by high wattage xenon bulbs will damage 35mm prints.

IF AT ANY TIME you have a suggestion, or desire aid in securing anticipated results, write STRONG INTERNATIONAL, 4350 McKinley Street, Omaha, Nebraska 68112.

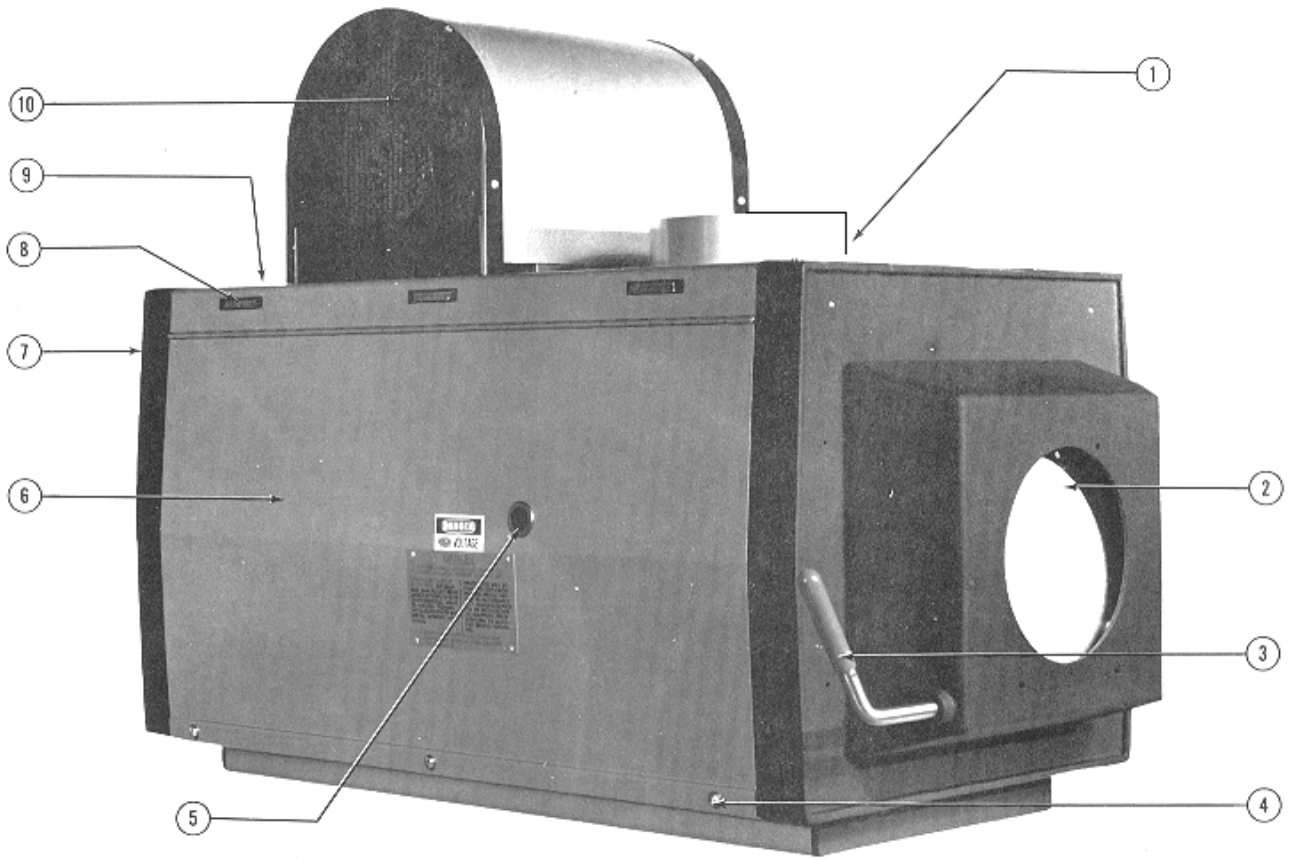

ULTRA 80 LAMPHOUSE

- | | |
|--------------------------|---------------------------------------|
| 1. Exhaust Stack, 8 inch | 6. Lamphouse Access Door |
| 2. Douser Plate | 7. Rear Casting & Instrument Panel |
| 3. Douser Control Handle | 8. Magnetic Door Catch (early models) |
| 4. Tamperproof Screw | 9. Emergency Ignition Switch* |
| 5. Arc Viewing Port | 10. Bulb Seal Blower |

* Emergency Ignition Switch located below Plug Button on Access Plate.

MECHANICAL LAMPHOUSE ALIGNMENT

ONE ALIGNING KIT consisting of an aligning cord, aperture plate, dummy lens, and centering plug is supplied with each lamphouse to provide an accurate and reliable method of optical alignment of the lamphouse to the projector mechanism. Because of the relatively small arc produced by the xenon bulb, good screen results can be obtained *only* by the careful use of this aligning kit.

PLACE THE LAMPHOUSE on the projection pedestal, making certain that it is centered between the ways. Open the side access door.

IF USING the optional Heat Filter, the filter holder bracket should be installed onto the lamphouse before aligning the lamphouse to the projector. Do not insert the filter until the following aligning procedure has been completed.

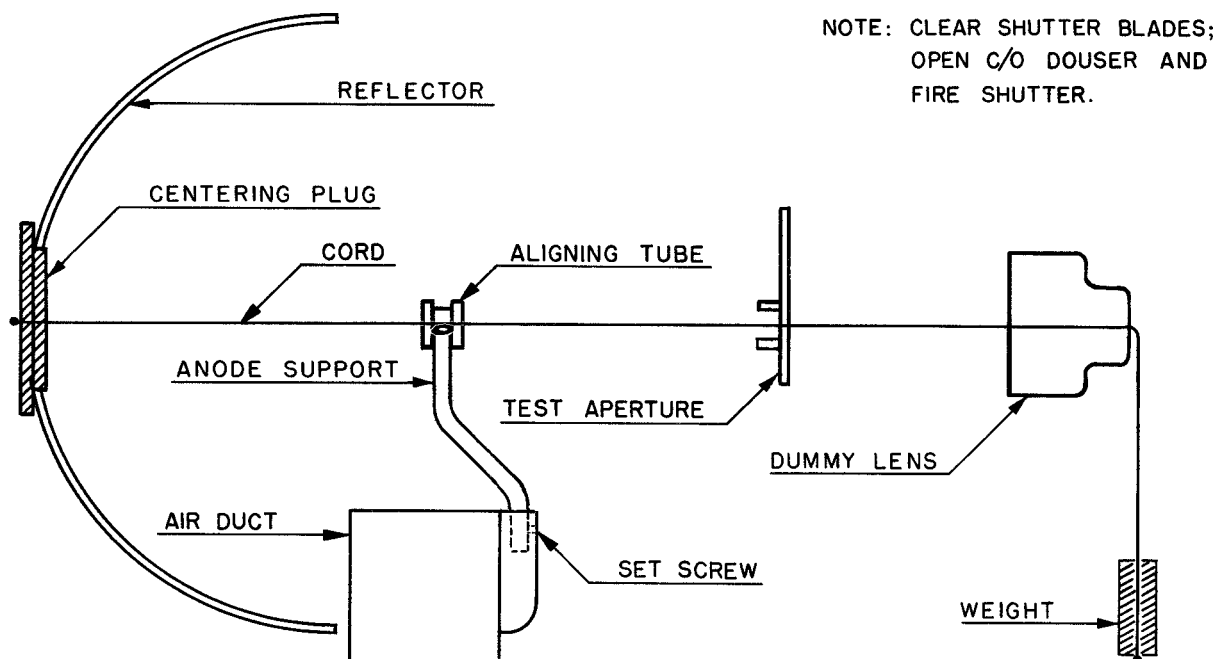

POSITION THE LAMPHOUSE on the table so the center of the reflector measures as near 34.5 inches from the projector aperture as the projector design will permit.

IN PREPARATION for optical alignment, bolt the lamphouse temporarily to the pedestal table using the 5/16-18 cap screws shipped with the lamphouse accessory kit.

INSERT THE CENTERING PLUG into the reflector opening, and secure the cord behind it as illustrated. Place the aligning tube on the anode support yoke and run the cord through it. Open the douser.

REMOVE THE PROJECTION LENS and pull the cord through the lens barrel. Pass the cord through the dummy lens and tie the cord to an object of sufficient weight to hold the cord taut. Position the test aperture as illustrated in the film trap of the projector. Close the film gate to hold the test aperture in place.

MOST PROJECTOR BASES have adjustable lamphouse tables so the lamp can be brought into optical alignment with the projector mechanism. If the lamphouse table is not adjustable, use shims or washers at the front, rear, or at both ends of the lamphouse to obtain optical alignment to the projector.

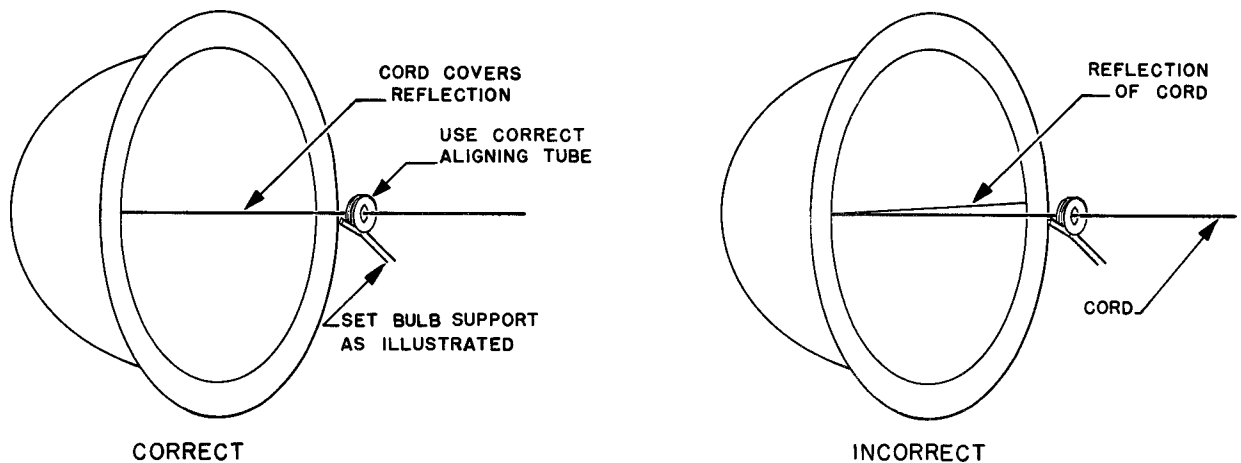

ALIGN THE LAMPHOUSE in relation to the projector so the cord passes through the center of the hole in the test aperture, and the correct cord image is seen on the reflector. Set the anode support yoke as illustrated and tighten the set screw in the air duct. DO NOT reposition the reflector, as it is factory prealigned for maximum optical efficiency.

ONCE CORRECT ALIGNMENT is achieved, tighten the lamphouse mounting screws to secure the lamphouse to the table. Remove the cord and associated fixtures and restore the operation of the fire shutter.

STORE THE ALIGNING KIT in a secure location in the projection booth. If the Ultra 80 reflector is ever removed or replaced, it is necessary to repeat the entire cord alignment procedure. Likewise, if a different type or wattage bulb is used in a subsequent relampment, it may be necessary to re-align the anode yoke to position it for the optical center of the replacement bulb.

EXHAUST SYSTEM INSTALLATION

THE EXHAUST DUCT of the Ultra 80 is designed to fit an eight inch diameter exhaust duct. This size ducting, either rigid or heat-resistant flexible, must be used throughout the complete exhaust system. The exhaust system must be vented to outside air, and installed in such a manner as to eliminate any possibility of downdraft or rain dripping into the lamphouse.

THE EXHAUST FAN must be capable of removing 700 cubic feet per minute (cfm) of air, as measured at the exhaust outlet of the lamphouse. If more than one lamphouse is connected to a common exhaust system, each individual lamphouse must meet the 700 cfm requirement.

IF THE EXHAUST AIR FLOW must be restricted for any reason, install bypasses rather than dampers in the exhaust line.

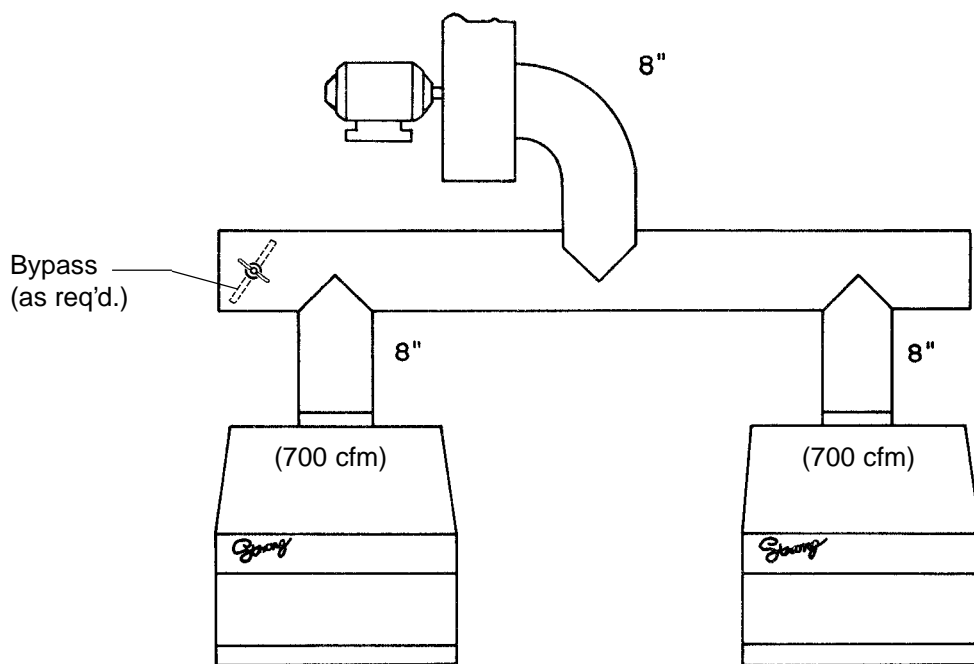

CHECK EACH LAMPHOUSE for correct exhaust air flow. Insufficient exhaust draft can severely shorten bulb life, and **no credit** will be allowed bulbs damaged in this manner. Inadequate exhaust may also cause possible injury to personnel by overheating the lamphouse enclosure.

THE XENON BULBS approved for use in the Ultra 80 are designated as *ozone free*. See "BULB INSTALLATION AND OPERATION."

LAMPHOUSE - POWER SUPPLY INTERCONNECTION DIAGRAM

Ultra 80

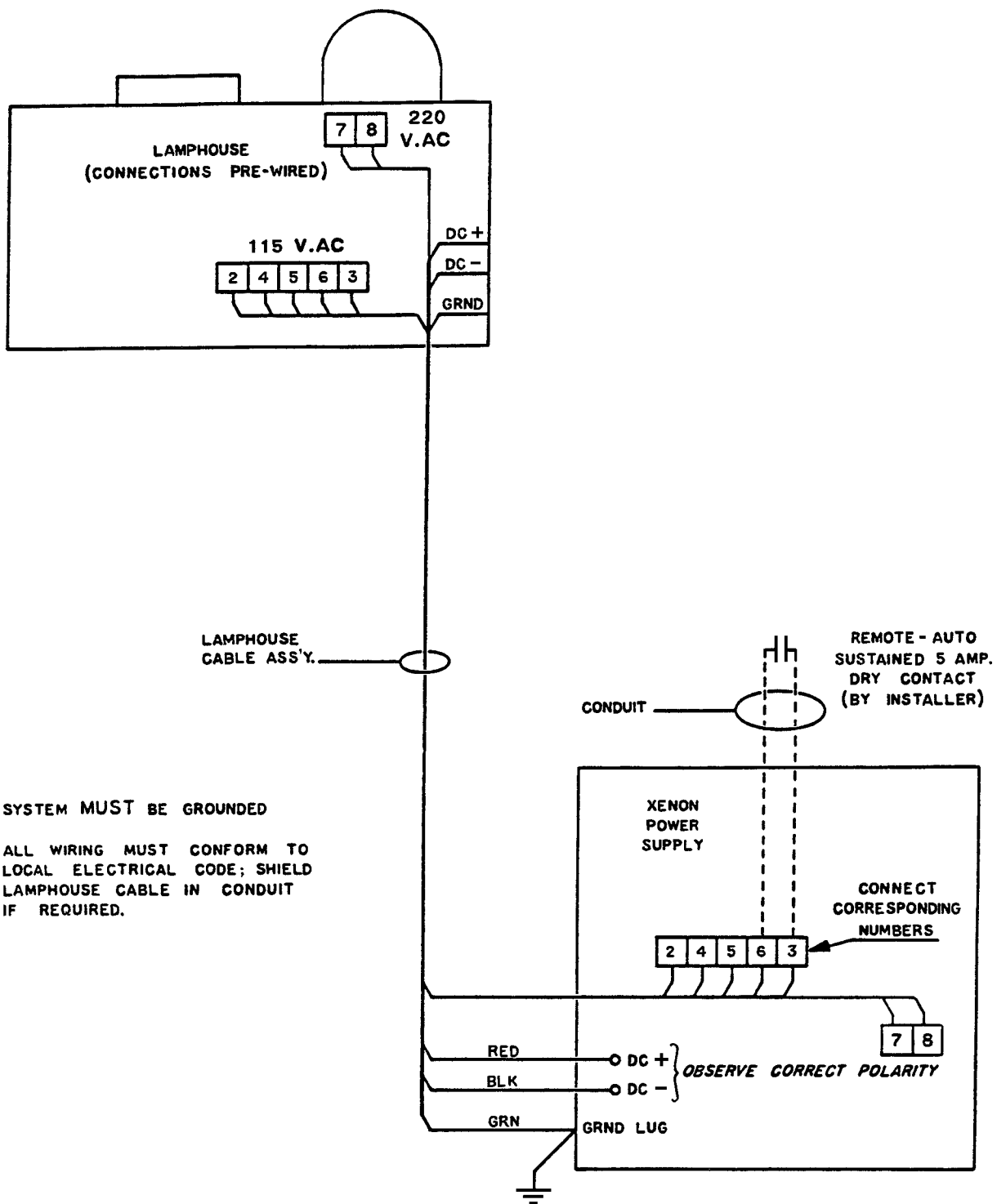

SYSTEM MUST BE GROUNDED

ALL WIRING MUST CONFORM TO LOCAL ELECTRICAL CODE; SHIELD LAMPHOUSE CABLE IN CONDUIT IF REQUIRED.

WIRING INSTALLATION

THE LAMPHOUSE LEADS must be connected to the xenon power supply as illustrated on the Installation Diagram.

CONNECT THE TWO HEAVY FIBREGLASS INSULATED LEADS to the DC outputs in the power supply. **Observe correct polarity**; red to positive (+), black to negative (-). Tighten connections securely to prevent overheating. Leads 2, 4, 5, and 6 provide the 115 V.AC control circuit between the lamphouse and power supply, and wires 7 & 8 (220 V.AC) power the lamphouse blower. Connect them to their corresponding numbered terminals on the barrier strip in the power supply cabinet.

COLOR CODE:

Brown	#2
Red	#3
Orange	#4
Blue	#5
Yellow	#6
Grey	#7
Black	#8

BECAUSE OF HIGH VOLTAGES impressed during the ignition cycle, the xenon lamphouse *must* be grounded. Connect the ground lead in the cable assembly (#8 AWG green) to the terminal lug in the power supply cabinet. Make certain that the power supply is connected to an adequate earth ground.

IF AUTOMATED or remote lamphouse switching is desired, it is generally more convenient to make such connections to the power supply barrier strip (3 & 6) as illustrated. See the "AUTOMATION SYSTEMS" section following for detailed instructions.

ALL LEADS may be run in conduit or greenfield if desired, or if required by local code. This may also be necessary as shielding to prevent electrical interference in the theatre sound system.

IT IS RECOMMENDED to establish a routine of periodically checking all electrical connections for tightness. Loose connections, particularly in the DC circuit, are subject to hazardous overheating.

SAFETY PROCEDURES

THE XENON BULB is highly pressurized. When ignited, the normal operating temperature of the bulb increases the pressure to a level at which the bulb may explode if not handled in strict accordance to the manufacturer's operating instructions. The bulb is stable at room temperature, but may still explode if dropped or otherwise mishandled.

REFER bulb replacement and service to QUALIFIED PERSONNEL with adequate protective clothing (face shield, clean cotton gloves, welder's jacket). For routine lamphouse service, observe the following rules:

1. Allow the bulb to cool to room temperature before opening the lamphouse. Put on protective clothing described above.
2. De-energize the xenon power supply at the AC source before opening the lamphouse compartment.
3. When possible, encase the bulb in its protective cover when cleaning or servicing the lamphouse interior. The bulb, when outside the lamphouse, must be encased in the cover.
4. Clean the bulb after it has cooled to room temperature. Do not touch the quartz envelope of the bulb; fingerprints will burn in and create hot spots which may shorten bulb life. If fingermarks are made, they should be carefully removed with methyl alcohol and cotton prior to bulb operation.
5. Never view an ignited bulb directly. **BLINDNESS OR PERMANENT EYE DAMAGE MAY BE INCURRED.**
6. Use only xenon bulbs designated as OZONE FREE. When possible, vent the lamphouse exhaust to outside atmosphere.
7. Maintain the lamphouse blower in good operating condition. Keep the blower inlet clean for unrestricted air flow.
8. To insure maximum bulb life, operate the lamphouse blower and the exhaust system for *at least* ten minutes after extinguishing the bulb.
9. If returning a bulb for warranty adjustment, pack it in its original shipping container. Complete and return all required warranty information.
10. Dispose of expired bulbs that are beyond warranty in the following manner: Wrap the bulb tightly in several layers of canvas or heavy cloth. Place it on a hard surface and shatter the envelope with a sharp hammer blow. DO NOT place an unshattered bulb in an ordinary refuse container.
11. **DO NOT PERMIT UNAUTHORIZED PERSONNEL TO PERFORM OR ATTEMPT ANY PHASE OF XENON BULB HANDLING OR SERVICE.**

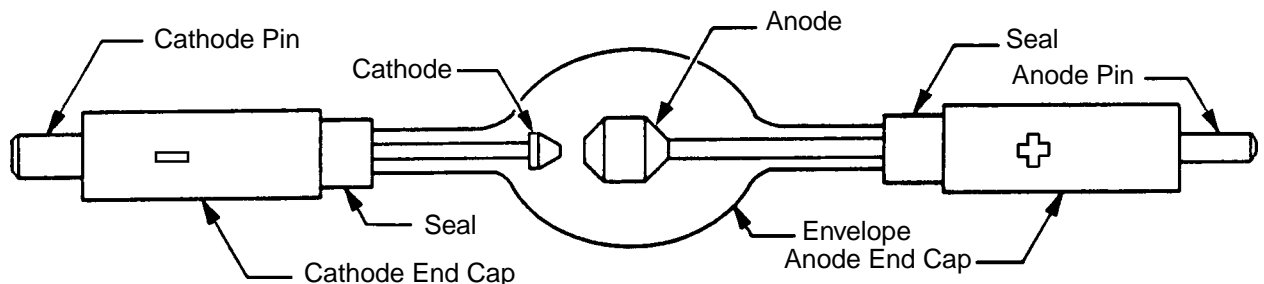

BULB INSTALLATION AND OPERATION

OBSERVE ALL SAFETY PROCEDURES. Bulb installation and replacement must be performed by QUALIFIED PERSONNEL with protective clothing and face shield.

THE XENON BULB requires no adapters to mount in the Ultra 80. All bulb mounting fixtures and electrical connections are designed for use with the designated xenon bulb (7000 watt for 40001; 10,000 watt for 40002). A silastic rubber tube is supplied with each lamp to permit insulating the bulb anode lead from the lamphouse base or other grounded metal components.

INSERT THE CATHODE (-) end of the bulb through the hole in the center of the reflector. Seat the cathode pin into the cathode support collet as far as possible to permit full focus travel of the bulb. Rest the anode (+) stem in the front support yoke and dress the anode lead directly in front of the air duct. Securely tighten the socket head screw in the cathode clamp, taking care not to apply any mechanical strain to the bulb vessel. Remove the hexnut, washer, and lockwasher from the anode binding post in front of the reflector. Connect the anode lead to the binding post and tighten securely.

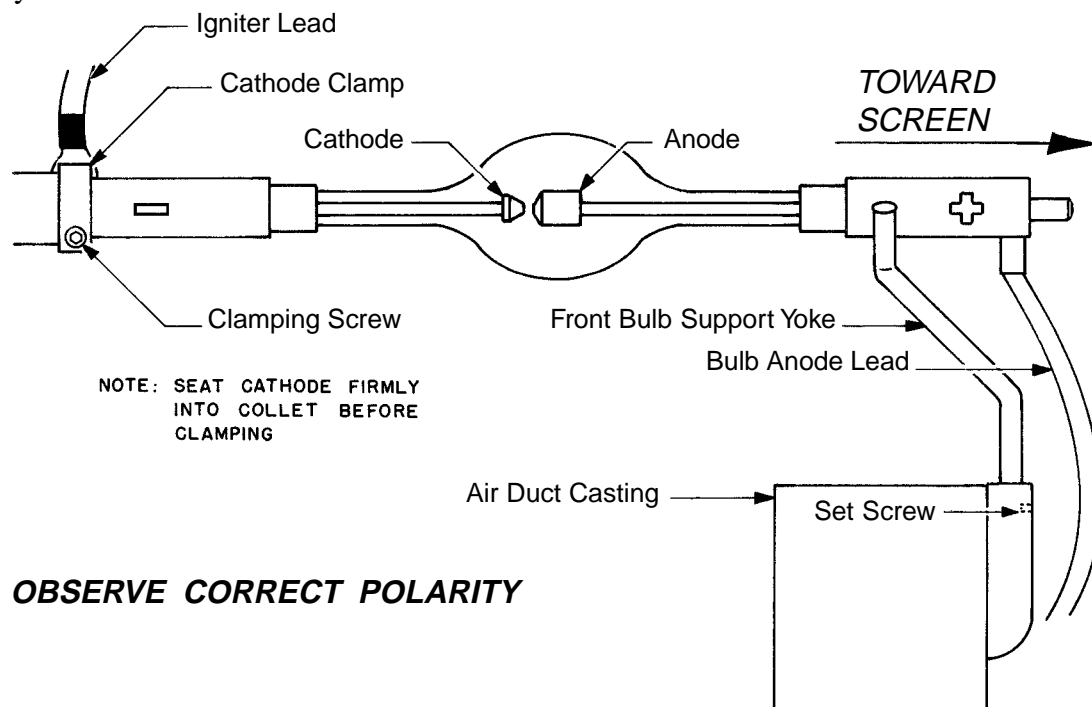

REMOVE THE PLASTIC PROTECTIVE COVER (when applicable) from the bulb. Close and secure the lamphouse door. **Turn on the exhaust system.** Place the MODE switch in the "MAN." position and close the douser.

TURN ON THE MAIN LINE SWITCH to energize the xenon power supply. The POWER light on the lamphouse instrument panel will glow, the blower will start, and the air vane switch will close to permit lamp operation. The lamphouse blower will operate continuously until the main line switch to the power supply is opened.

PLACE THE LAMP SWITCH in the "ON" position and the bulb will ignite. Allow the current to stabilize, and check the lamphouse ammeter. Set the power supply as required to supply 120-150 amperes to the 7000 watt bulb, or 150-180 amperes to the 10,000 watt bulb; DO NOT exceed maximum rated current.

IF IGNITION does not occur, or the high voltage ignition pulse is not apparent, press the emergency ignition switch located under the plug button on the top of the lamphouse. Do not hold for more than **one second**; release immediately on bulb ignition. See the TROUBLESHOOTING section following in this manual.

THE SMALL PUSHBUTTON SWITCH located directly above the ammeter may be pressed while the lamp is operating to convert the meter reading to indicate the DC voltage at the arc. This permits immediate calculation of the power at which the lamp is operating. Holding this switch in at the ignition pulse will briefly display the "no load" voltage applied to the bulb for ignition.

REMOVE THE REAR COVER PANEL (two pull type knobs) to expose the bulb position adjustment controls.

BULB ADJUSTMENT CONTROLS

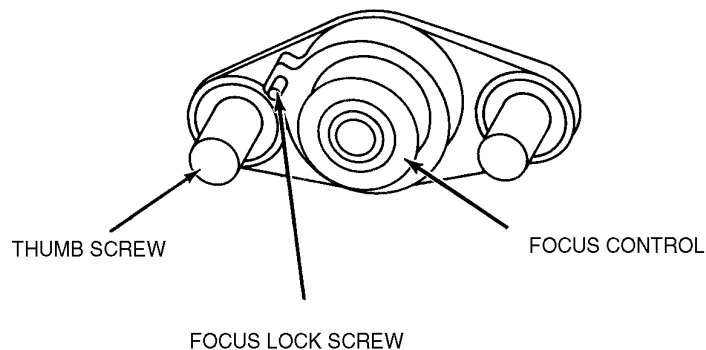

THE THUMB SCREWS on either side of the focusing control lock the horizontal and vertical adjustment mechanism in position.

REMOVE THE PROJECTION LENS, start the projector, and open the douser. Do not operate the lamp without the projector running.

TURN THE CENTER FOCUSING SECTION of the bulb position control until the smallest black spot obtainable is focused on the projection screen. It may be best to run this adjustment both directions to permit positive identification of the spot. The position of the spot may be to the right, left, top or bottom of the screen, and not necessarily in the center.

LOOSEN the two thumb screws, one on either side of the focusing section, just enough to permit manual movement of the complete assembly. The bulb adjustment control will now move about these two thumb screws, and as this control is shifted, the smooth shadow of the electrode can be seen extending beyond the projected hole in the reflector. The electrode shadow must be centered inside the projected hole of the reflector.

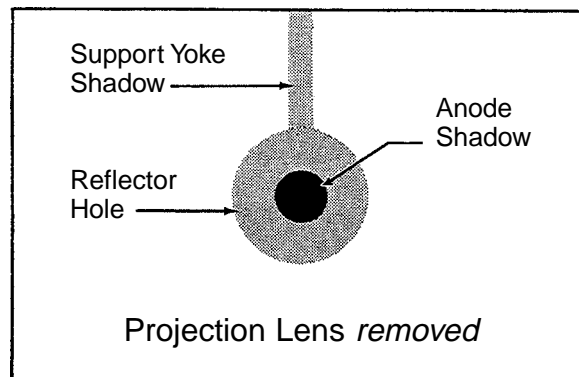

MOVE THIS CONTROL SECTION around the two thumb screws until the black spot is as round as possible to project. It may be necessary to again adjust the focus control to define a sharp spot. After the black spot is as even as possible to project, tighten the two thumb screws to lock the adjustment section. This adjustment has now centered the projected image of the electrode shadow and the hole in the reflector on the aperture and screen.

REPLACE THE PROJECTION LENS and rotate the focus adjustment until the desired light distribution is projected to the screen. Avoid running the projector in this manner for an extended period of time without *frequently* closing the lamphouse douser. Without film, the heat from the xenon bulb can damage the projection lens.

THIS ADJUSTMENT should not be disturbed until it is necessary to replace or rotate the xenon bulb. Then, only the bulb adjustments outlined above may have to be repeated; do not disturb or adjust the optical alignment of the lamphouse on the projector table.

REPLACE THE REAR COVER PANEL over the bulb adjustment control mechanism. Press plungers into grommets to secure.

BECAUSE OF MANUFACTURING TOLERANCES on the xenon bulb, and normal aging, it may necessary to operate one lamp of a two-machine installation at slightly higher or lower current to obtain equal light balance on the screen. This is done by adjusting the output of the xenon power supply.

TO EXTINGUISH the arc, place the LAMP switch in the "OFF" position. The lamphouse blower will continue to operate until the main switch in the AC power line to the xenon power supply is opened.

TO PROLONG BULB LIFE, leave the blower and exhaust fan operate for *at least* ten minutes after turning off the lamp. Allow the bulb to cool to room temperature before opening the lamphouse access door for any reason.

A PERMANENT MAGNET is mounted behind the reflector to stabilize the arc between the electrodes of the ignited bulb. The magnet requires no adjustment. If the magnet is removed for any reason, it must be replaced with the SOUTH pole nearest the lamphouse access door. The south pole is stamped "S" and marked with paint.

AUTOMATION SYSTEMS

TO INTERCONNECT the lamp to an automation system, two #16 AWG wires (not supplied by Strong) must be installed as illustrated on the Interconnection Diagram. These wires must be shielded to prevent interference in the theatre sound system.

NOTE: Lamp ignition in “AUTO” mode is effected by a sustained dry contact closure between terminals 3 and 6. DO NOT apply voltage to these terminals. Refer to instructions furnished by the manufacturer of the automation controller.

TO OPERATE with an automation system, place the MODE switch in the “AUTO” position, and the LAMP switch to “ON.” When the xenon power supply is energized, the lamphouse POWER light will glow, and the blower will operate. The bulb will not ignite until provided a dry contact between 3 and 6 by the automation controller. Opening this contact will extinguish the bulb, and allow the POWER light and the blower to continue to operate.

IN THE EVENT of an automation failure, manual control of the lamp can be restored by placing the MODE switch in “MAN.” and switching “ON or “OFF” with the LAMP switch.

MAINTENANCE

THE ULTRA 80 LAMPHOUSE requires very little maintenance to keep it in good working order. Cleanliness is the most important element.

THE REFLECTOR should be cleaned periodically with a soft, clean, lint free cloth to remove any dust from the reflecting surface. If excessively soiled, use of a mild commercial glass cleaner (Windex® or equivalent) is acceptable; USE NO ABRASIVE CLEANERS.

THE XENON BULB should be checked occasionally for the presence of foreign material on the envelope. Any dirt or other foreign material should be removed promptly. Use only alcohol and a clean cloth to clean the bulb; rinse with distilled water and dry carefully. DO NOT touch the bulb with bare fingers, and observe all safety procedures when working around the bulb.

THE INSIDE OF THE LAMPHOUSE and the impeller blades of the blower should be cleaned periodically, depending on the dust conditions at each installation. The grilles over the air intakes can be removed for cleaning; do not allow dirt or dust to build up on the grille or in the fan impeller.

THE XENON LAMPHOUSE does not require any lubrication other than at the blower(s). Use two or three drops of non-detergent motor oil every four to six months. The oil holes are located on the motor portion of the blower. Removing the blower covers will not affect the mounting of the blowers.

CHECK ALL ELECTRICAL CONNECTIONS periodically for tightness, especially the DC leads at the xenon bulb and at the shunt and igniter. Inspect crimped joints for oxidation, and remake the connection if oxidized.

FOLLOW THE RECOMMENDATIONS of the xenon bulb manufacturer regarding periodic bulb rotation. It is a general practice to rotate the bulb 180° at 50% of warranty life. After rotating a bulb, increase current to the maximum allowable level, and operate the bulb at this elevated level for three or four shows.

ALWAYS allow the lamphouse blower and the exhaust system to operate for *at least* ten minutes after extinguishing the bulb. Failure to do so will shorten bulb life.

ULTRA 80

LAMPHOUSE SCHEMATIC

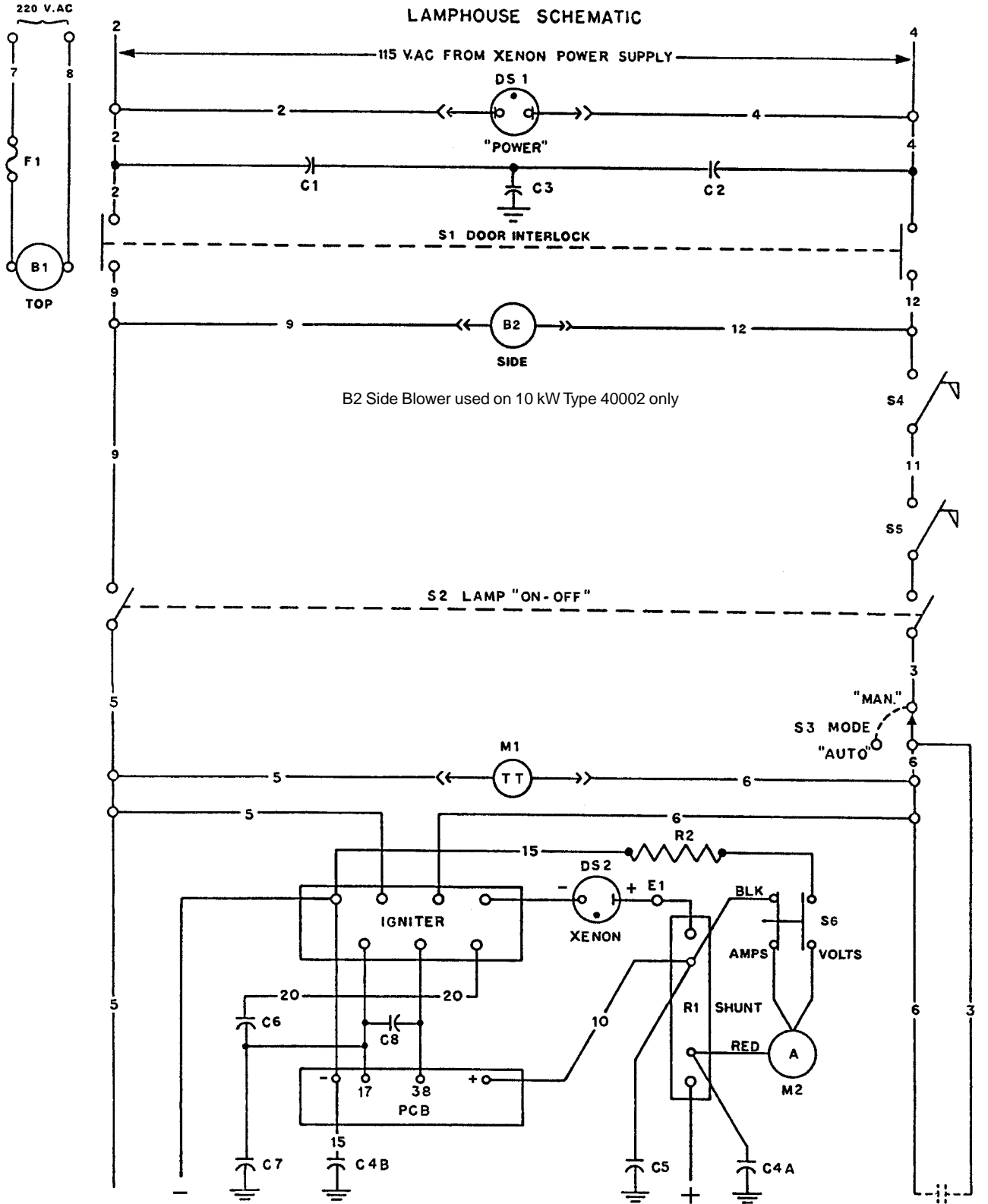

5 & 6: 115 V.AC to Power Supply Contactor (K1)
 3 & 6: 5 Amp. Dry Contact for Remote-Auto Switching (by Installer)

SCHEMATIC DIAGRAM
Parts List

Ref		
<u>Desig.</u>	<u>Part No.</u>	<u>Description</u>
B1	40220	Bulb Seal Blower, 220 V.AC, 50/60 Hz.
B2	47944	Reflector Blower Assembly 115 V.AC, 50/60 Hz.
		<i>* B2 Used with 10,000 Watt Type 40002 ONLY *</i>
C1,2	76132	Capacitor, .005 µf, 600 WVDC
C3	76133	Capacitor, .01 µf, 400 WVDC
C4A,B	76323	Capacitor, 1.0-1.0 µf, 600 WVDC
C5	81947	Capacitor, .05 µf, 500 WVDC
C6,7	88263	Capacitor, .05 µf, 600 WVDC
C8	39956	Capacitor, .05 µf, 2000 WVDC
DS1	78984	POWER Indicator Light, 115 V.AC
DS2	-	Xenon Bulb, 7000 Watt; Order Hanovia XH7000HS
DS2	-	Xenon Bulb, 10,000 Watt; Order Hanovia XH10000V(H)
E1	40987	Binding Post, DC Positive (+)
-	40131	Fibre Insulator
F1	40203	Fuse, 3 Amp. Slo-Blo
-	39199	Fuse Holder
M1	40971	Elapsed Time Meter, 60 Hz.
-	40963	Elapsed Time Meter, 50 Hz.
M2	40923	Ammeter, 0 - 300 Amp.
PCB	40913	Igniter Printed Circuit Board Assembly (Standard)
-	40984	Igniter PC Board (with High Reactance Power Supply)
R1	81247	Shunt, 50 mV.
R2	71283	Resistor, 90.9k Ohm, ¼ Watt, 1%
S1	80168	Door Interlock Switch
S2	81275	LAMP Switch, "ON - OFF"
S3	81276	MODE Switch, "AUTO - MAN."
S4	39955	Air Vane Switch Assembly (Exhaust)
S5	85109	Air Vane Switch (Intake)
S6	72275	Voltage Test Switch
-	39999A	Igniter Assembly
-	40902	Interconnect Cable, Lamphouse to Power Supply

Specify Equipment Type and Serial Number when ordering replacement parts.

PRINCIPLE OF IGNITER OPERATION

THE IGNITER is energized through the 115 V.AC control circuit when the LAMP “ON-OFF” switch (S2) is depressed and all interlocks and air flow switches are closed.

CAUTION: Do not use the Emergency Ignition switch (S102) in the igniter until it is determined that the polarity of the xenon bulb is correct. Use of the S102 switch bypasses the polarity sensing diode (CR201) on the igniter printed circuit board; if polarity is not correct, the bulb will be seriously damaged or destroyed. **No credit** is allowed on bulbs damaged by reversed polarity.

THE IGNITER supplies a high RF voltage pulse to the bulb, together with the high “No Load” DC voltage from the xenon power supply, to ignite the xenon bulb. After the arc is sustained, the AC circuit in the igniter is interrupted by the opening of K201 relay contacts on the signal of the timer circuit on the PC board. The DC output of the xenon power supply is automatically lowered to the power level required to maintain the arc. The DC power to the bulb is dependent upon the bulb characteristics and the setting of the output of the xenon power supply.

DC VOLTAGE is applied to the printed circuit board from the xenon power supply, energizing the 12 V.DC coil and closing the contacts of K201 relay, completing the AC circuit through the igniter to the T102 high voltage (10 kV.) transformer. High voltage boost capacitor C107 is charged to a voltage sufficient to cause breakdown across the E101 spark gap. Approximately 35 kV. is supplied to the xenon bulb for ignition.

S101 is the igniter cover interlock switch and S102 is the Emergency Ignition switch, which is a bypass for the K201 relay contacts and CR201 polarity sensing diode on the PC board. Components C101, 102, and 103 function as RF bypass capacitors on the igniter. The C108 capacitor serves as a coupling capacitor to the current coil.

THE PC BOARD operates on DC voltage from the xenon power supply. Capacitor C201 across the positive #10 and negative #15 is an RF suppression capacitor. Resistor R201 and zener diodes VR201 and 202 drop the DC voltage to 12 volts for the K201 relay coil. CR201 is the polarity sensing diode. C204 is a polarized capacitor used for arc suppression at the K201 relay coil, and CR202 functions as a transient protection diode.

THE FOLLOWING COMPONENTS are parts of the timing circuit on the PC board: Timer chip U201, resistors R202, 203, and the polarized capacitor C203. The C203 capacitor functions as the timing control, and CR203 serves as the “ON” time control diode. C202 is the control voltage isolation capacitor.

IGNITER SCHEMATIC

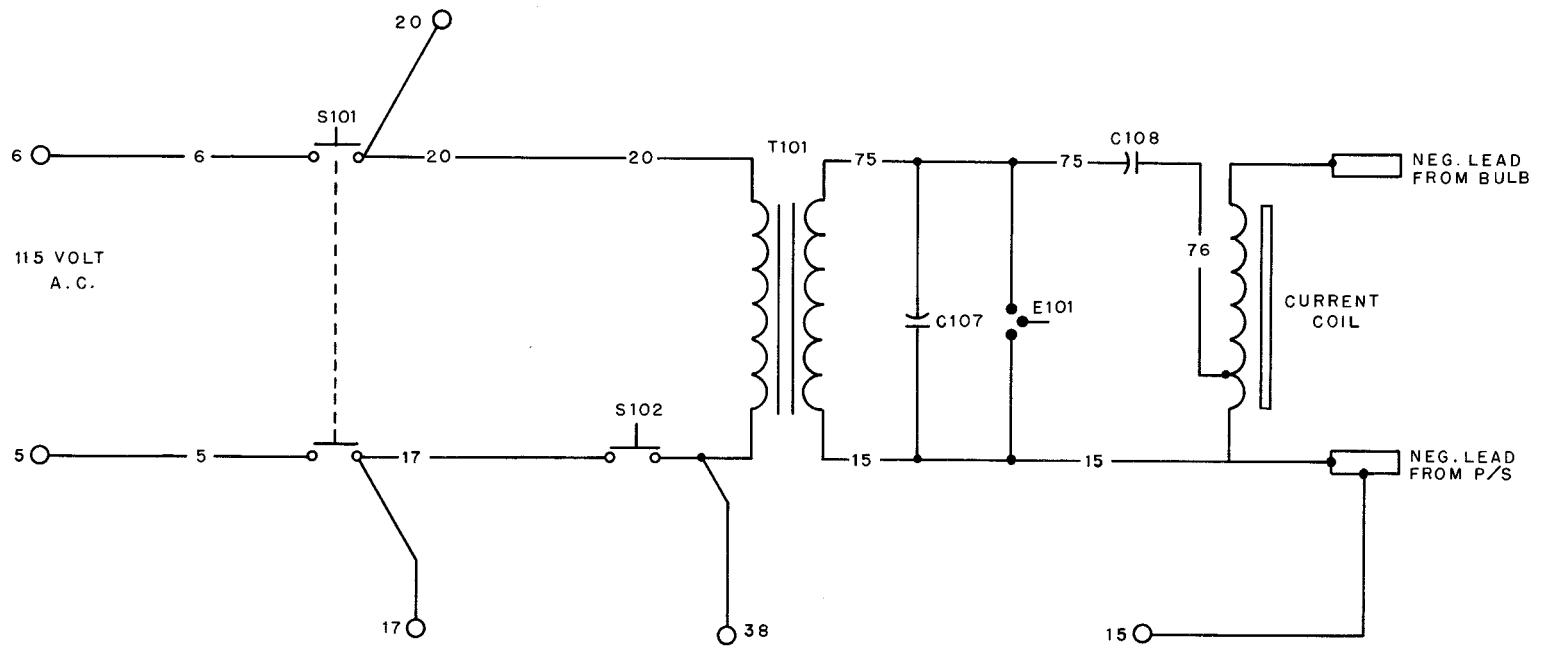

U80/018

<u>Ref. Desig.</u>	<u>Part No.</u>	<u>Description</u>
C107	39110	Capacitor, 2400 pf, 20 kV.DC
C108	39110	Capacitor, 2400 pf, 20 kV.DC
E101	39923	Spark Gap Assembly
S101	80168	Cover Interlock Switch
S102	80168	Emergency Ignite Switch
T101	39937	High Voltage Transformer
-	39998	Case & Coil, Potted Assembly

IGNITER PRINTED CIRCUIT BOARD SCHEMATIC

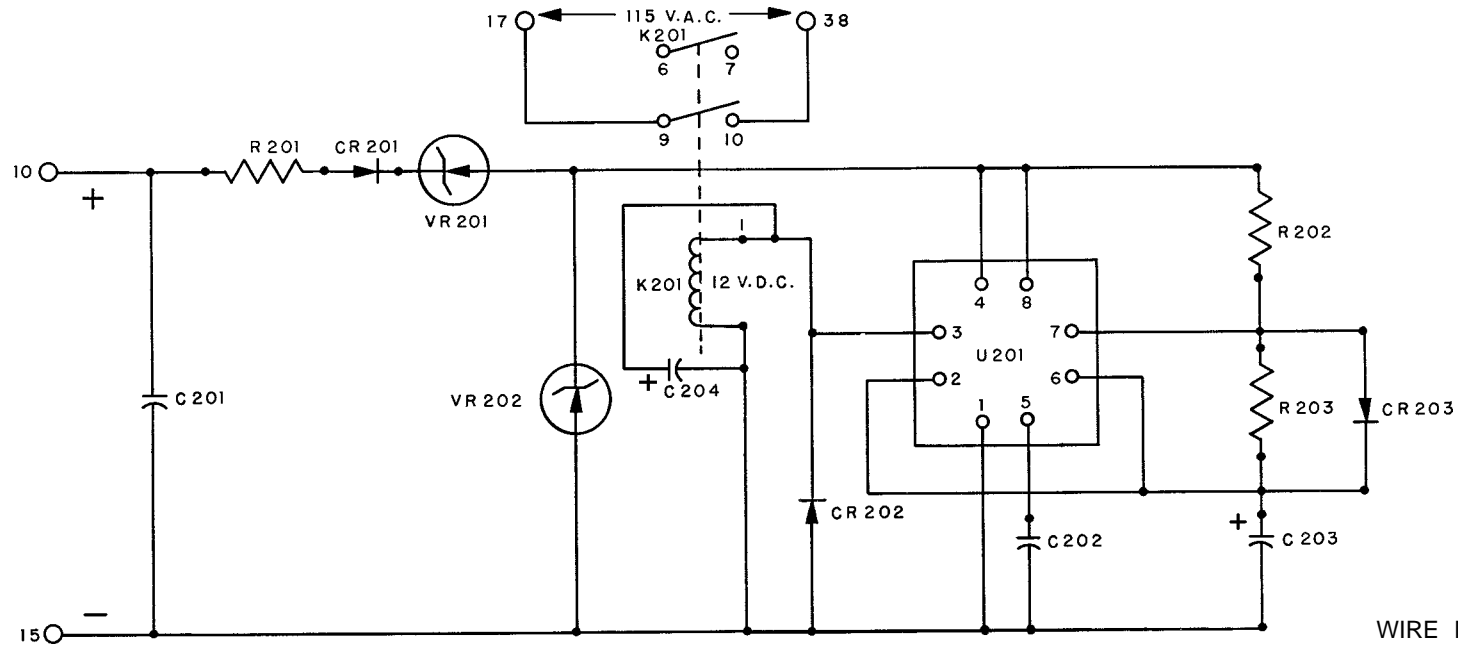

WIRE MARKERS
 A = 10
 B = 15
 C = 17
 D = 38

Ref. Desig.	Part No.	Description
C201	88263	Capacitor, .05 μ f, 600 WVDC
C202	79127	Capacitor, .01 μ f, 600 WVDC
C203	39156	Capacitor, 15 μ f, 30/35 WVDC
C204	88249	Capacitor, .1 μ f, 600 WVDC
CR201	85112	Diode, 2.5 A. 1000 PRV
CR202	85112	Diode, 2.5 A. 1000 PRV
CR203	85112	Diode, 2.5 A. 1000 PRV
K201	39154	Relay, P&B R10-E1-W2S800
-	39160	Relay Socket
-	39161	Relay Hold-Down Spring
R201	39157	Resistor, 1k Ohm, 12 Watt
R202	39158	Resistor, 100k Ohm, 1/2 Watt

Ref. Desig.	Part No.	Description
R203	39159	Resistor, 200k Ohm, 1/2 Watt
U201	72185	Timer IC, Motorola MC11455P1
-	39164	IC Socket, (6) Pin
VR201	39211	Zener Diode, 1N5377A (40913*)
VR201	81519	Zener Diode, 1N5361 (40984*)
VR202	39162	Zener Diode, 1N4742
-	39145	PC Board (less Components)
*	40913	PCB Assembly, Standard
*	40984	PCB Assembly (Older Models using High Reactance Power Supply)

Assembly Number written on Component Side of PCB.

TROUBLE CHART

NOTE: When working inside the lamphouse, enclose the xenon bulb in its protective covering and/or wear protective clothing and face shield. Do not touch the quartz envelope of the bulb with bare fingers.

ALLOW THE LAMPHOUSE to cool, with all blowers operating, for at least (20) minutes before opening the access door.

Normal Operation:

When the switch in the main AC supply line to the xenon power supply is placed in the "ON" position, with the door interlock switch closed, the lamphouse POWER light will glow and the lamphouse blower(s) will operate. The top lamphouse blower will close the S4 air vane switch, and the correct operation of the exhaust system will close the S5 air vane switch. These conditions complete the circuit to the S2 LAMP "ON-OFF" switch.

Place the lamphouse MODE switch S3 in the "MAN." position. When the lamphouse LAMP switch S2 is in the "ON" position, the elapsed time meter will operate and the AC circuit (5 - 6) to the xenon power supply will energize the circuitry necessary to supply DC voltage to the igniter and bulb.

There will be an audible high voltage arc ping at the spark gap in the igniter and at the xenon bulb. The bulb should ignite immediately after one or two of these high voltage pulses, and the lamp current will adjust to the sustaining level set at the xenon power supply. An aged or "warm" xenon bulb may require repeated ignition cycles.

Troubleshooting:

If the xenon bulb does not ignite, observe the following operational sequences for assistance in locating and isolating the trouble area.

When operating with a xenon power supply equipped with the red indicator light, and the light is "ON," the AC circuit in the power supply is trouble free up to the terminal block (L1, L2, L3) in the power supply.

The blower(s) the lamphouse and the POWER light on the instrument panel should operate. If this does not occur, the trouble is in either the door interlock switch, a blower motor, the indicator lamp, a loose connection, a broken #2, #4, #7 or #8 lead, or a defective stepdown transformer in the xenon power supply. The Ultra 80 has an in-line fuse in the 220 volt blower circuit; check the fuse and replace if blown. Do not overfuse; use 3 A. slow blow.

CAUTION: To prevent bulb ignition when checking the AC control circuit, remove the #6 lead running from the igniter at the terminal post on the lamphouse base pan. Tape the exposed lead to prevent shorting out the circuit.

Check the 115 V.AC control circuit in the lamphouse at the door switch, then the control leads at terminals #9 and #12 (the “side” blower on 40002 lamp). The door interlock switch must be manually actuated to energize this circuit.

The air flow from the top blower will move the actuating lever on switch S4, and the exhaust draft should close switch S5. With the MODE switch in the “MAN.” position, and the LAMP switch in the “ON” position, the elapsed time meter should start to indicate elapsed time. If this meter does not operate, check for continuity at the LAMP and MODE switches. Check continuity of the air flow switches; both should read 0 Ohms between “NO” and “COM” when actuated. A defective elapsed time meter will *not* prevent bulb ignition. Replace lead #6.

With the LAMP switch in the “ON” position, a distinct high voltage arc ping at the igniter spark gap should be heard, and a flash from the xenon bulb should be visible through the ammeter, as DC voltage is applied to the bulb electrodes.

If the high voltage ping or the flash at the ammeter is not apparent, check the DC “No Load” voltage between the lamphouse and power supply. Again disconnect lead #6 running from the igniter at the terminal strip on the lamphouse base. Tape the end of the disconnected lead and close and secure the lamphouse door.

Press the switch above the ammeter, and the meter will indicate the “No Load” DC voltage supplied to the lamphouse when the LAMP switch is turned “ON.” This voltage will vary between different types of power supplies. See your power supply manual for its correct “No Load” rating.

The standard 40913 igniter printed board in the Ultra 80 is designed for use with a Strong switching power supply with high DC “No Load” voltage. Consult the factory if using an older high reactance xenon power supply with normally lower DC “No Load” voltage.

If the correct voltage for the power supply being used is not indicated on the meter, the problem is in the lamphouse/power supply interconnecting cable, or in the power supply. See the troubleshooting guide in the power supply manual for additional instructions and tests. Replace lead #6 on the terminal strip on the lamphouse base.

If the high voltage arc is audible at the lamphouse, and the bulb does *not* flash, replace the bulb and attempt ignition with the new bulb.

Using the new bulb, if the high voltage arc is audible at the lamphouse, the flash of the bulb is visible in the ammeter, and ignition is *not* sustained, the problem is in the power supply.

If the high voltage arc is *not* audible or the flash of the bulb visible, the trouble is in the igniter or the igniter printed circuit board.

ULTRA 80 TROUBLESHOOTING

Bulb fails to ignite.

1. AC power not on to lamphouse. If 115 V.AC not read at 2 & 4, see power supply manual. Check for loose 220 volt connection at 7 & 8.
2. Door interlock switch S1 open. Close and secure lamphouse access door. Tighten all three screws; lock door and install security screw.
3. Faulty door interlock switch. Check for 115 V.AC at 9 & 12; replace switch if defective.
4. Air vane switch S4 not closing. Check for unobstructed operation; clean if required. Check continuity between “NO” and “COM”; replace if defective.
5. Faulty S2 “ON-OFF” switch. Check for voltage at 3 & 5; check for loose wiring. Replace if defective.
6. Automation fault. Override automation by switching MODE to “MAN.” and placing LAMP switch in “ON.” See Automation Controller manual.

Bulb fails to ignite; ping audible, bulb flash visible.

1. Inadequate DC output from xenon power supply. Set power supply output to correct range required for bulb wattage.
2. Faulty or expired xenon bulb. Replace as required.

Bulb fails to ignite; ping audible, no bulb flash.

1. Faulty xenon bulb. Check for cracked electrodes or darkened envelope. Replace if defective.
2. Ignition pulse shorting to ground. Inspect DC leads for burned insulation; dress leads away from grounded metal components.

No high voltage ping audible; MODE switch in “MAN.” and LAMP switch in “ON.”

1. Loss of AC control voltage. Check xenon power supply for tripped circuit breaker or open thermal switch. See power supply manual.
2. Little or no DC “No Load” voltage. Measure DC “No Load” voltage at 10 & 15. See power supply manual.
3. Faulty igniter printed circuit board. If bulb ignites by pressing Emergency Ignition switch, replace printed circuit board.
4. Faulty igniter. Check for 115 V.AC at 5 & 6; adequate DC “No Load” at 10 & 15. Replace igniter if defective.

Bulb goes out during operation.

1. Xenon power supply overheated; thermal switch open. Check power supply blower(s), air inlets and outlets unobstructed. See power supply manual.

Bulb goes out during operation (con'd.)

2. Lamphouse blower B1 failed or obstructed. Clean dust and dirt from blower inlet grille. Check for 220 V.AC at 7 & 8; replace blower if defective.
3. Blower fuse F1 blown. Replace if defective (3 A. Slo-Blo).
4. Lamphouse air vane switch S4 or S5 faulty. Check for vane motion and switch continuity ("NO" to "COM"); adjust or replace as required.
5. Backdraft from exhaust system. Check exhaust system installation; increase exhaust draft as required.
6. Intermittent relay closure in automation controller. Override automation by switching MODE to "MAN." and check automation controller.
7. Phase loss or brown-out in xenon power supply AC source. Check AC input.

Power supply does not energize when actuated.

1. S1 door interlock switch, B1 blower, S4 air vane switch, S2 power switch, S3 MODE switch. Check for correct voltage at each station; replace defective component.
2. Automation fault. Check for continuity between 3 & 6. See Automation Controller manual. Use "MAN." mode to override.

ALSO SEE POWER SUPPLY TROUBLESHOOTING

Noise in theatre sound as bulb ignites.

1. Faulty RF suppression capacitor(s). Remove and test C1, C2, C3, C4A or C4B. Replace if defective.
2. Lamphouse, power supply, or sound system not properly grounded. Connect to adequate earth ground.
3. Leads between lamphouse and automation contact not shielded. Shield leads in conduit.

Excessive light flicker.

1. Faulty or aged bulb. Check for cracked or sagging electrodes; replace if defective.
2. Arc stabilization magnet missing or reversed. Replace or correct (SOUTH pole toward access door).
3. Excessive ripple in DC output. See power supply manual.
4. Projector shutter mistimed. See projector manual.

Reduced light output.

1. Normal bulb aging. Increase output current. **DO NOT EXCEED MAXIMUM CURRENT SPECIFIED BY BULB MANUFACTURER.**
2. Bulb leakage. Check for high current and low voltage; discoloration of bulb envelope. Replace if defective.
3. Soiled reflector. Clean using commercial glass cleaner. **USE NO ABRASIVES.**
4. Soiled projection lens or port glass. Clean as required.

Extremely long duration between ignition pulses.

1. Low DC “No Load” from xenon power supply. Check “No Load” voltage; see power supply manual.
2. Defective spark gap E101. A “Ping” sound is normal; excessive “Hissing” is abnormal. Replace if defective.
3. Low AC voltage to lamphouse. Check for 115 V.AC at 2 & 4; if below 95 volts, check stepdown transformer in xenon power supply. See power supply manual.
4. Faulty K201 relay or U201 timer chip on igniter printed circuit board. Remove and test PCB; replace if defective.

Igniter continues to fire after bulb ignites.

1. Faulty igniter printed circuit board. If defective, replace IMMEDIATELY to prevent bulb damage.

U80/025

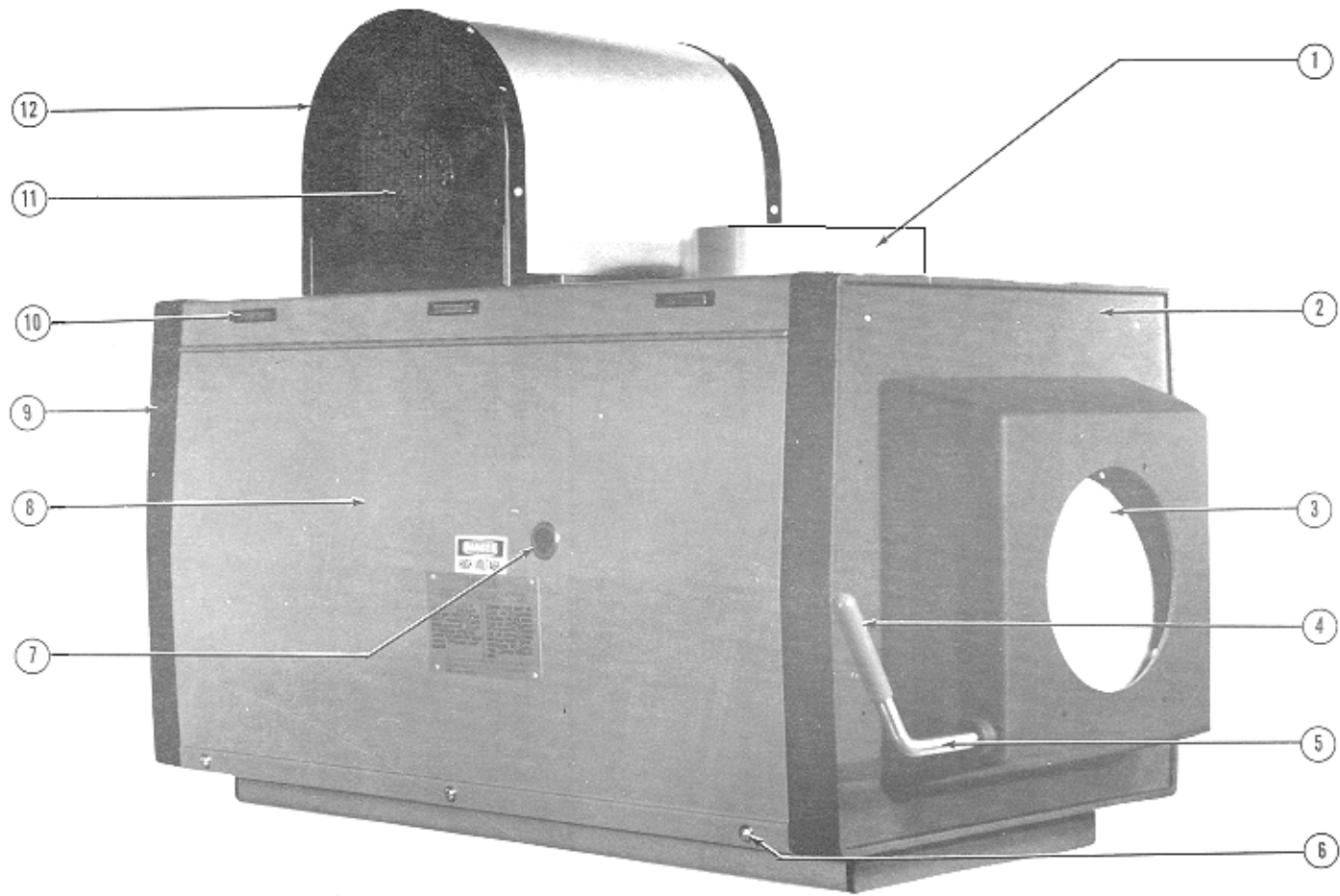

FIGURE 1

FIGURE 1
Parts List

<u>Item</u>	<u>Part No.</u>	<u>Description</u>
1	40917 *	Top Cover & Door Welded Assembly
2	40994	Front Casting Assembly (with Items 3, 4, 5)
-	40106	Front Casting (only)
-	40137	Front Heat Shield
3	81148	Douser Plate
-	81432	Shoulder Screw
-	81234	Bumper Stop
-	81187	Torsion Spring
-	00721	Set Screw, 10-32 x 3/8" Hex Head
4	45150A	Handle Grip, Plastic
5	40115	Douser Shaft
6	01736-1	Tamperproof Screw, 10-32 x 1/2" Holt Head
7	48930	Arc Viewing Port Assembly
8	40917 *	Top Cover & Door Welded Assembly (See Item 1)
-	71248	Cam Lock & Keys (not shown)
9	40105	Rear Casting
10	39139	Magnetic Door Catch
11	40220	Bulb Seal Blower, 220 V.AC, 50/60 Hz. (B1)
-	31-40002	Plug, Blower Motor
-	11-40019	Power Receptacle, Blower Motor
12	40920	Grille, Blower Cover (2 req'd.)
	40194	Blower Cover

NOT SHOWN

-	40989	Instrument Panel Assembly (See Fig. 2 for components)
-	01423	Panel Mounting Screw, 10-32 x 5/16" Pan Head
-	39122	Ingiter Cover Access Plate
-	01304	Cover Mounting Screw, 8-32 x 5/16" Pan Head
-	00891A	Lockwasher, #8
-	57275	Plug Button, Emergency Ignition Switch
-	40918 *	Off-Operator Side Cover & Heat Shield Welded Assembly, 7 kW (less Reflector Blower)
-	40903 *	Off-Operator Side Panel Assembly, 10 kW (with Reflector Blower)
-	01345	Panel Mounting Screw, 10-32 x 1/2" Pan Head
-	00885	Lockwasher, #10
-	47944	Reflector Blower Assembly 115 V.AC, 50/60 Hz. (B2)
-	31-40002	Twistlock Plug
-	11-40019	Twistlock Receptacle

* Do not dismount Top Cover and Side Cover simultaneously; optical alignment may be affected.

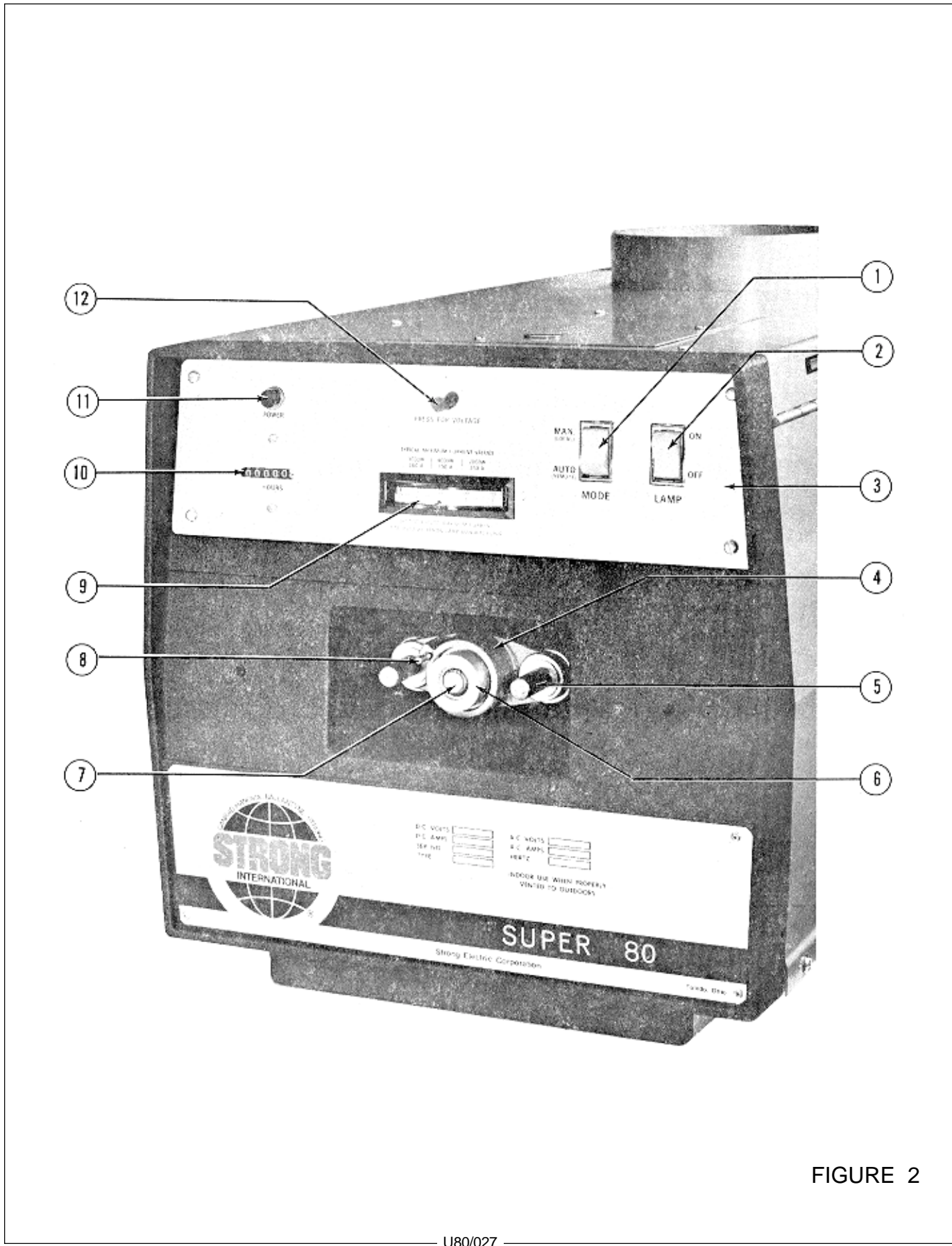

FIGURE 2

FIGURE 2
Parts List

<u>Item</u>	<u>Part No.</u>	<u>Description</u>
1	81276	MODE Switch (S3)
2	81275	LAMP Switch (S2)
3	40102	Plate, Instrument Panel (less Components)
-	01423	Screw, 10-32 x 5/16" Pan Head
4	65116	Casting, Bulb Adjustment Mechanism
-	65197	Fender Washer, Inner
5	37985	Thumb Screw
-	15010	Compression Spring
-	65150	Fender Washer, Outer
6	65959	Focus Screw & Bearing Assembly
7	40930	Bulb Collet, 7 kW (See Figure 3, Item 16)
7	40901	Bulb Collet, 10 kW (See Figure 3, Item 16)
-	21-48027	Collet Retaining Ring, "C" Clip
8	65153	Thumb Screw, Focus Lock
-	65154	Nylon Locking Ball
9	40923	Ammeter (M2)
10	40971	Elapsed Time Meter (M1) 60 Hz.
-	40963	Elapsed Time Meter (M1) 50 Hz. Mounting Hardware supplied with Meter
11	78984	POWER Light (DS1)
12	72275	Voltage Test Switch (S6)
-	71283	Resistor (R2)

NOT SHOWN

-	40119	Cover Plate, Bulb Adjustment Controls
-	65166	Plunger, Black Plastic
-	65167	Grommet, Black Plastic

U80/029

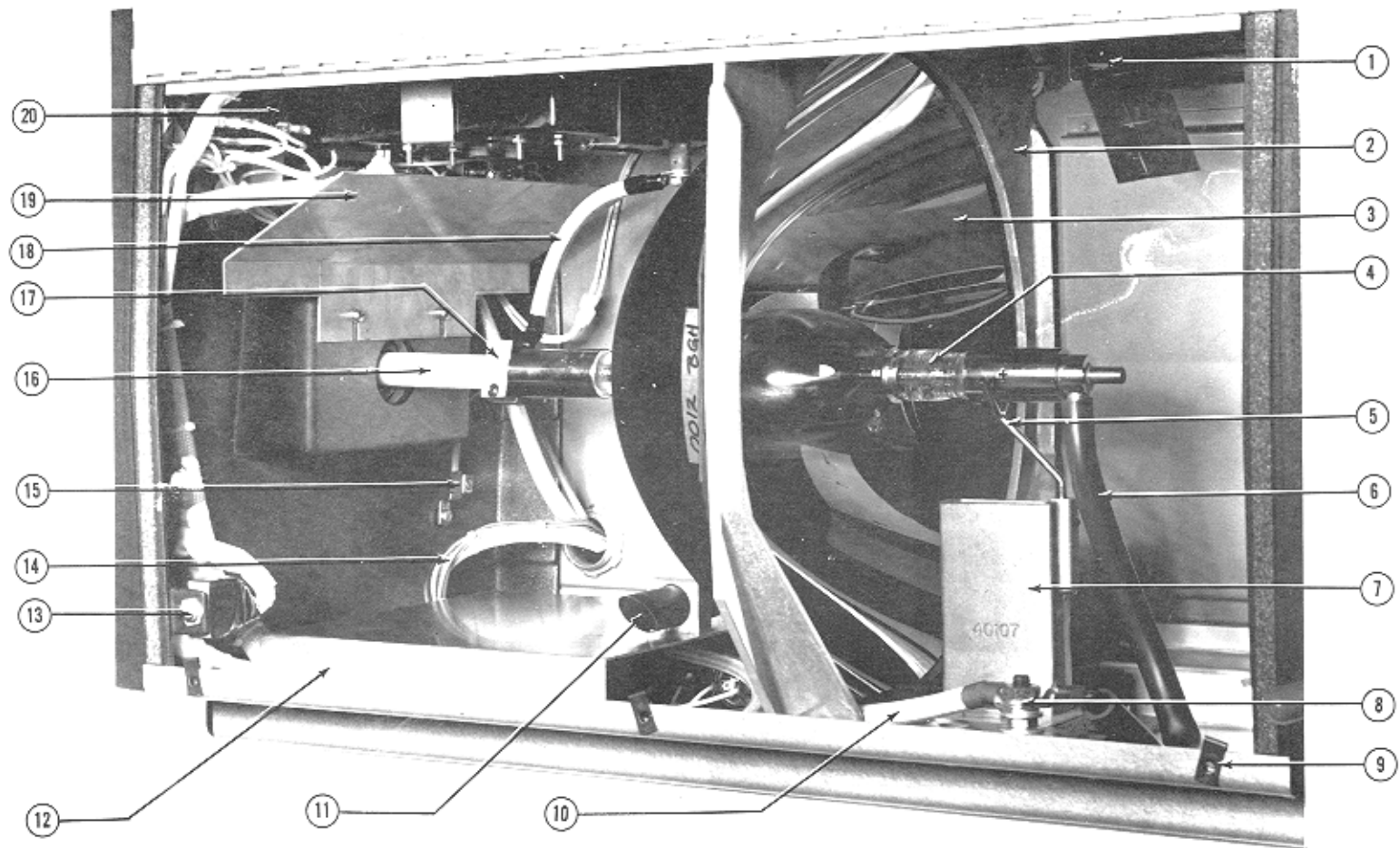

FIGURE 3

FIGURE 3
Parts List

<u>Item</u>	<u>Part No.</u>	<u>Description</u>
1	39955	Exhaust Air Vane Switch Assembly (S4)
2	40202	Reflector Bulkhead Casting
-	40142	Bulkhead Tie Rod
-	00805	Hex Nut, 1/4-20
3	23754	Reflector, 15" Dichroic Coated, Flanged
4	-	Xenon Bulb, 10,000 Watt; Order Hanovia XH10000V(H)
4	-	Xenon Bulb, 7000 Watt; Order Hanovia XH7000HS
5	40999	Bulb Support Yoke
-	00781	Set Screw, 8-32 x 1/4" Allen Head
6	81348	Insulator, Anode Lead (NOT USED in Ultra 80)
7	40107	Air Duct Casting
-	40116	Air Duct Insulator Plate
-	01796	Screw, 5/16-18 x 3/4" Nylon
8	40987	Binding Post Assembly (E1)
-	40130	Block, Brown Phenolic
-	00642	Screw, 3/8-16 x 1-1/2" Flat Head
-	00809	Jam Nut, 3/8-16
-	00854	Flatwasher, 3/8"
-	40131	Fibre Insulator
-	00492	Screw, 1/4-20 x 3/4" Flat Head
-	00876	Split Lockwasher, 1/4"
-	00805	Hexnut, 1/4-20
10	40981	Anode Cable Assembly (R1 to E1)
11	M15315	Arc Stabilization Magnet
-	81137	Magnet Clamp
-	00781	Set Screw, 8-32 x 1/4" Allen Head
-	01710	Screw, 8-32 x 1/4" Hex Head
12	40120	Dust Cover
-	01742	Screw, 8-32 x 1/4" Pan Head
-	00891A	Lockwasher, #8
13	80168	Door Interlock Switch (S1)
14	40902	Lamphouse/Power Supply Interconnect Cable Assembly
-	81143	Cable Connector, 90°
15	81274	Ground Lug
-	01423	Screw, 10-32 x 5/16" Pan Head
-	00891A	Lockwasher, #8

FIGURE 3 Parts List (con'd.)

<u>Item</u>	<u>Part No.</u>	<u>Description</u>
16	24432	Bulb Support Collet, 5 kW*
16	40930	Bulb Support Collet, 7 kW
16	40901	Bulb Support Collet, 10 kW
17	24430	Collet Contact Clamp, 5 kW*
-	41-51213	Clamping Screw, 10-32 x 1" Socket Head
-	00685	Screw, 1/4-20 x 3/8" Hex Head
17	40111	Collet Contact Clamp, 7 & 10 kW
-	01532	Clamping Screw, 8-32 x 7/8" Socket Head
-	00685	Screw, 1/4-20 x 3/8" Hex Head
18	40979	Contact Clamp & Igniter Lead Assembly
19	40164	Light Baffle
-	01566	Screw, 10-24 x 5/16" Pan Head
-	00885	Lockwasher, #10
20	39999A	Igniter Assembly (See Figure 5A)

* for 5 kW *Osram* with 18mm Cathode Pin. Other 5 kW bulbs emulate 4 kW and 4.5 kW models. Consult bulb supplier.

NOT SHOWN

-	85109	Intake Air Vane Switch, Bulb Seal Blower (S5)
-	65158	Switch Mounting Bracket

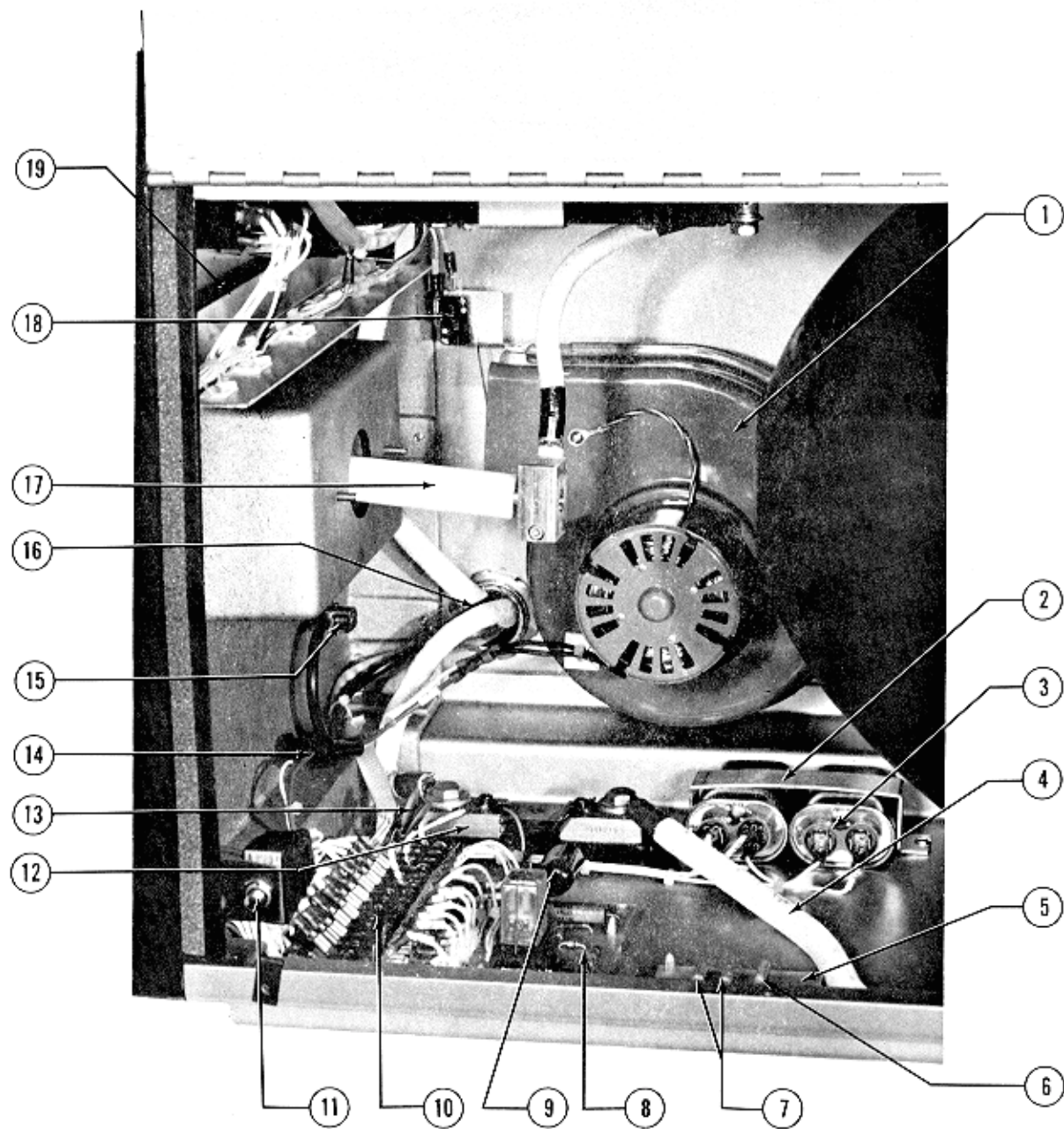

FIGURE 4

FIGURE 4
Parts List

<u>Item</u>	<u>Part No.</u>	<u>Description</u>
1	-	Not Used in Ultra 80; See Figure 1, Item 11
2	40136	Capacitor Clamp
-	01382	Screw, 8-32 x 3/16" Pan Head
-	00891A	Lockwasher, #8
3	76323	Capacitor (C4A, C4B) 2 req'd.
4	40981	Anode Cable Assembly (R1 to E1)
5	40983	RF Capacitor Assembly (C1, C2, C3)
-	39153	Nylon Standoff
6	76133	Capacitor (C3)
7	76132	Capacitor (C1, C2)
8	40913	Igniter Printed Circuit Board Assembly
-	40984	Igniter PC Board (with High Reactance Power Supply)
-	39153	Nylon Standoff
-	39154	Relay (See PCB Schematic)
9	40974	Capacitor (C8)
10	40103	Barrier Strip, (14) Terminal
-	40138	Insulated Marker Strip
-	01799	Screw, 8-32 x 9/16", Round Head
-	00891A	Lockwasher, #8
11	80168	Door Interlock Switch (S1)
12	81247	Shunt (R1)
-	01312	Screw, 8-32 x 1/2" Pan Head
-	00891A	Lockwasher, #8
13	40973	RF Bypass Capacitor Assembly (C6, C7)
14	39199	Fuse Holder
-	40203	Fuse (F1)
15	81274	Ground Lug
-	01423	Screw, 10-32 x 5/16" Pan Head
-	00885	Lockwasher, #10
16	40902	Lamphouse/Power Supply Interconnect Cable Assembly
-	81143	Cable Connector, 90°
17	40901	Bulb Support Collet, 10 kW (See Figure 3, Item 16)
18	85109	Air Vane Switch (S5) Mounted to Top Blower in Ultra 80
-	65158	Switch Mounting Bracket
19	40164	Light Baffle (See Figure 3, Item 19)

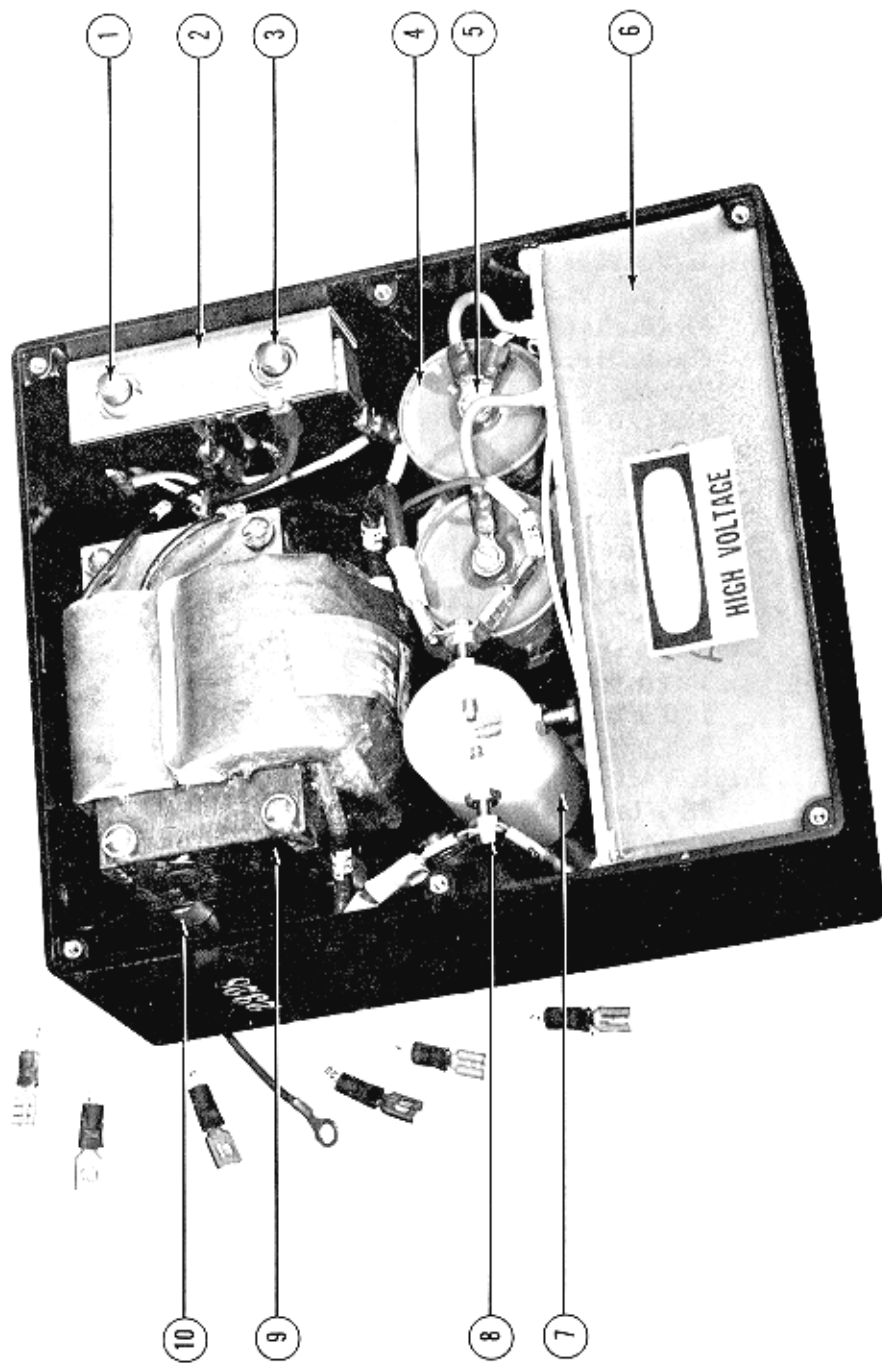

FIGURE 5

FIGURE 5
Parts List

<u>Item</u>	<u>Part No.</u>	<u>Description</u>
-	39999A	Igniter Assembly 115 V.AC, 50/60 Hz.
1	39260	Cover Interlock Switch (S101)
2	39113	Switch Bracket
-	00343	Screw, 10-32 x 1/4" Flat Head
3	39260	Emergency Ignition Switch (S102)
4	39110	High Voltage Capacitor (C107, C108)
-	00254	Screw, 8-32 x 1/4" Fillister Head
-	00891A	Lockwasher, #8
-	39112	Capacitor Mounting Bracket
-	01752	Screw, 1/4-20 x 1" Hex Head Nylon
-	01754	Hex Nut, 1/4-20 Nylon
5	01742	Screw, 8-32 x 1/4" Pan Head
-	00981A	Lockwasher, #8
6	39998	Case & Coil Potted Assembly
-	65353	DANGER Label
7	39201 *	Spark Gap Body, Nylon
-	01567	Screw, 10-24 x 1/2" Pan Head
8	39107 *	Contact Screw, Tungsten
-	39109	Terminal Tab (Order KT-74)
-	00831	Flatwasher, #10, Brass
-	00795	Hex Nut, 8-32
9	39937	High Voltage Transformer (T102)
-	01582	Flatwasher, #8
-	00795	Hex Nut, 8-32
10	39204	Transformer Spacer (4 req'd.)
*	39923	Spark Gap Assembly (Items 7 & 8, assembled and gapped)

NOT SHOWN

39101	Igniter Box Cover, Plastic
01305	Screw, 6-32 x 1/4" Pan Head

