

Film-Tech

The information contained in this Adobe Acrobat pdf file is provided at your own risk and good judgment.

These manuals are designed to facilitate the exchange of information related to cinema projection and film handling, with no warranties nor obligations from the authors, for qualified field service engineers.

If you are not a qualified technician, please make no adjustments to anything you may read about in these Adobe manual downloads.

www.film-tech.com

Instructions

**FOR
EQUIPMENT
Type**

**X-60 C LAMP
81001-1
3-1-75**

STRONG ELECTRIC
87 CITY PARK AVE., TOLEDO, OHIO

PREFACE

OBSERVE ALL SAFETY PROCEDURES. The xenon bulb operates with a high internal pressure and servicing should be referred to qualified personnel.

THIS IS A REFLECTOR TYPE, direct current projection lamphouse using a xenon bulb as the light source and only xenon bulbs designed for horizontal operation should be used in the X-60 lamphouse.

THE REFLECTOR is an interference coated deep ellipse type, designed to operate in a fixed position at 34 inches from the projection film line.

THE SPECIAL POWER SUPPLY manufactured by Strong Electric, is the only power source that can be used with the X-60 projection lamphouse.

ADJUSTMENT CONTROLS to position the xenon bulb in relation to the reflector are located on the lower right side of the lamphouse. The two rear knobs provide for the horizontal and vertical movement of the bulb and the knob at the front adjusts the focus of the bulb in relation to the reflector.

THE LAMPHOUSE is equipped with an ammeter to indicate the operating current of the lamp and an elapsed time meter to show the number of hours the lamp has operated.

CURRENT CONTROL for the lamphouse is located on the power supply. A tap panel and dial switches are provided for this adjustment. See the power supply manual for adjustment instructions.

THE LAMPHOUSE BLOWER is internally wired and operates on 220 V.A.C. This blower is required to keep the bulb seals at a safe operating temperature.

AIRFLOW SAFETY INTERLOCK SWITCHES are installed at the lamphouse exhaust stack and the bulb seal blower. Inadequate air flow to close either one or both of these switches will interrupt the A.C. control circuit and prevent ignition of the xenon bulb.

SAFETY INTERLOCK SWITCHES are located in the lamphouse at the side door and rear access panel. Both must be secured before the bulb will ignite.

THE LAMP "ON-OFF" rocker type switch, in the "ON" position, energizes the A.C. supply circuit to the running time meter, seal cooling blower, the igniter and completes the circuit for ignition of the xenon bulb.

THE "MODE" rocker type switch provides the means of operating the equipment from a remote "Automatic" system or when placed in the "Man. " position, from the lamphouse.

THE IGNITE PUSH BUTTON SWITCH is provided for ignition of the xenon bulb from the lamphouse, when the "Mode" switch is in the "Man. " position.

IF AT ANY TIME you have a suggestion, or desire aid in securing anticipated results, please feel free to write directly to STRONG ELECTRIC, P.O. Box 1003, 87 City Park Ave., Toledo, Ohio 43697.

SAFETY PROCEDURES

THE XENON BULB has high internal pressure. Therefore extreme care should be taken when handling the bulb. Refer servicing to qualified service personnel. To minimize any danger, the following rules should be followed.

1. CAUTION: BULB EXPLOSION HAZARD. Relamping to be done only by QUALIFIED SERVICE PERSONNEL with protective clothing and face shield.

2. Turn power off at main line switch before opening the door or rear access panel.

3. The xenon bulb when outside the lamphouse must be encased in its plastic protective cover.

4. The lamphouse must be properly vented to the outside atmosphere. See Exhaust Systems installation in this manual.

5. The bulb shall be inserted into the lamphouse while still encased in its protective cover. The cover should be removed only after all the necessary cable connections have been made and the door is ready to be closed. When removing the bulb from the lamphouse, it should be encased in the cover before the bulb cables are disconnected from the anode feed-through connector and igniter.

6. Clean the bulb only after it has cooled to room temperature. Never touch the glass envelope of the bulb; fingerprints will burn in and dull the bulb. If fingerprints are made, they should be carefully removed from the bulb with methyl alcohol and cotton.

7. Do not open the lamphouse when the bulb is in operation. Wait at least 20 minutes for the bulb to cool after turning off power.

8. Never look directly at the ignited bulb - TO DO SO MAY CAUSE BLINDNESS.

9. Encase the bulb in its protective cover when cleaning the lamphouse interior.

10. Dispose of expended bulbs that are beyond warranty immediately in the following manner. Wrap the bulb with several layers of canvas or heavy cloth, and smash with a hammer, before depositing in a refuse container.

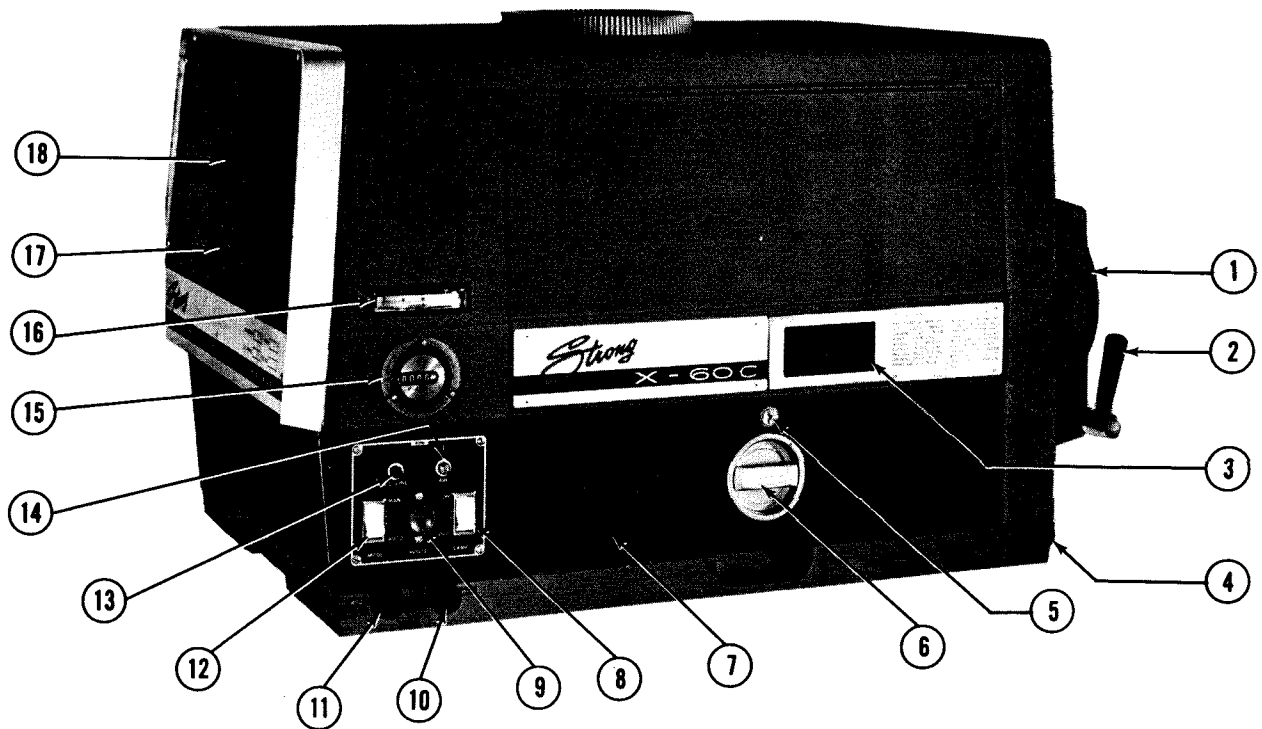

- | | |
|---------------------------------|---|
| 1. Safety Glass | 11. Horizontal Control Knob |
| 2. Douser Handle | 12. Auto-Man Mode Switch |
| 3. Arc Viewing Port | 13. A. C. Power Indicator Lamp |
| 4. Focus Control Knob | 14. Interlock System Indicator Lamp |
| 5. Door Lock | 15. Elapsed Time Meter |
| 6. Door Latch Bar | 16. Ammeter |
| 7. Door Interlock Actuator Knob | 17. Plug Button (Emergency Ignition Switch) |
| 8. Lamp On-Off (power) Switch | 18. Rear Access Panel |
| 9. Ignition Switch | |
| 10. Vertical Control Knob | |

EXHAUST SYSTEM INSTALLATION

THE EXHAUST STACK of this lamphouse is designed to fit an eight inch diameter pipe. This size pipe must be used through the complete exhaust system and installed to eliminate any possibility of down draft or rain dripping on the xenon bulb. (See illustration below.) The exhaust fan must be capable of removing 700 lineal feet of air per minute at each lamp. A minimum of 650 lineal feet is required to operate the lamphouse exhaust air vane switch. Do not install the xenon bulb until the exhaust system has been adjusted.

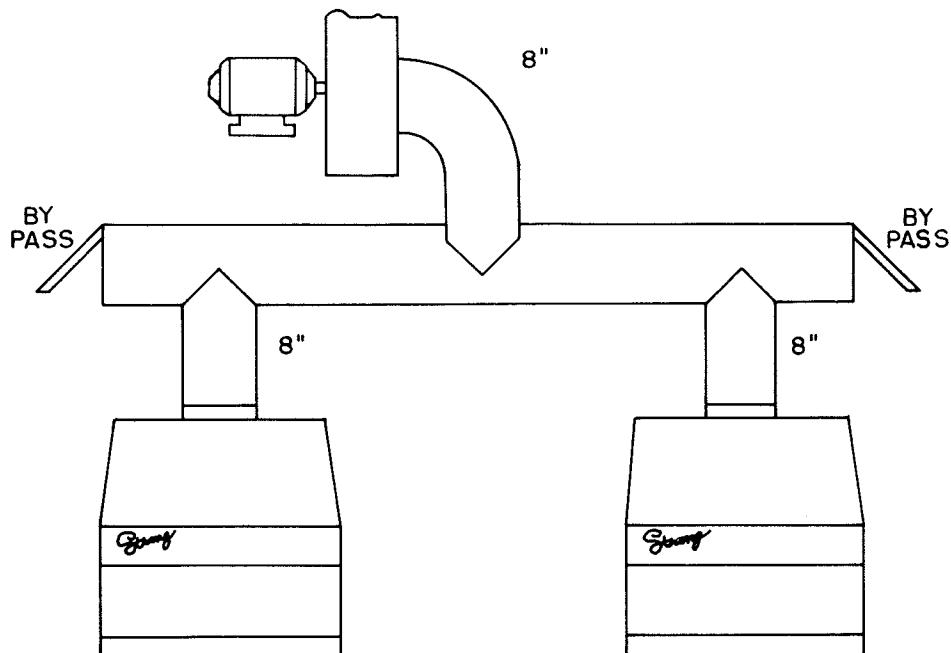

ONE DRAFT GAUGE is enclosed in an envelope attached to this instruction book. The gauge is designed for 700 lineal feet per minute. Follow the instructions for use printed on the gauge. If your exhaust system holds the draft gauge when the lamphouse door is closed, it is meeting the air flow requirements. Do not attempt to reduce the air flow by restricting the full 8-inch pipe opening either by the use of a damper or smaller pipe.

AN EXHAUST SYSTEM that has proven adequate for 150 ampere carbon arc operation will be suitable for the xenon installation providing it has been thoroughly cleaned and tested with the draft gauge to verify the draft is meeting the requirements.

WIRING INSTALLATION

UNLOCK THE SIDE DOOR and turn the door interlock actuator knob counter-clockwise to its full open position. This must be done to clear the door latch system and permit turning the latch bar clockwise to its vertical position to release the door.

REMOVE THE REAR ACCESS PANEL from the lamphouse, to permit access to the Ground Lug and to the A.C. control terminal block. Remove the six (6) screws from the outside of the panel, reach inside the lamphouse through the side door opening and release the spring clip located in the center of the panel just above the igniter. Spring out the top of the panel and lift up to release the panel from the retaining strip at the bottom.

ALL WIRES between the lamp and power supply must be shielded by enclosing them in Greenfield or conduit, to prevent electrical interference from feeding into the theatre sound system.

CONNECT THE RECTIFIER to the lamphouse as shown on the installation wiring diagram. The two heavy asbestos leads coming from the rectifier should be connected to the two heavy asbestos leads coming from the lamp. Polarity must be observed. Connect Red to Red and Black to Black.

FEED FOUR #14 AWG WIRES for the A.C. control circuit and one #8 AWG ground wire (not supplied by manufacturer) through the small right angle connector on the side of the lamp. Connect the #14 AWG wires from the terminal block in the lamphouse to the corresponding terminals in the rectifier.

DUE TO HIGH VOLTAGES impressed during the ignition cycle, the xenon lamphouse must be grounded. A ground terminal, is provided inside the lamphouse just to the left of the terminal block. Connect the #8 AWG wire from this terminal to a suitable ground.

REPLACE THE REAR ACCESS PANEL.

INSTALLATION DIAGRAM

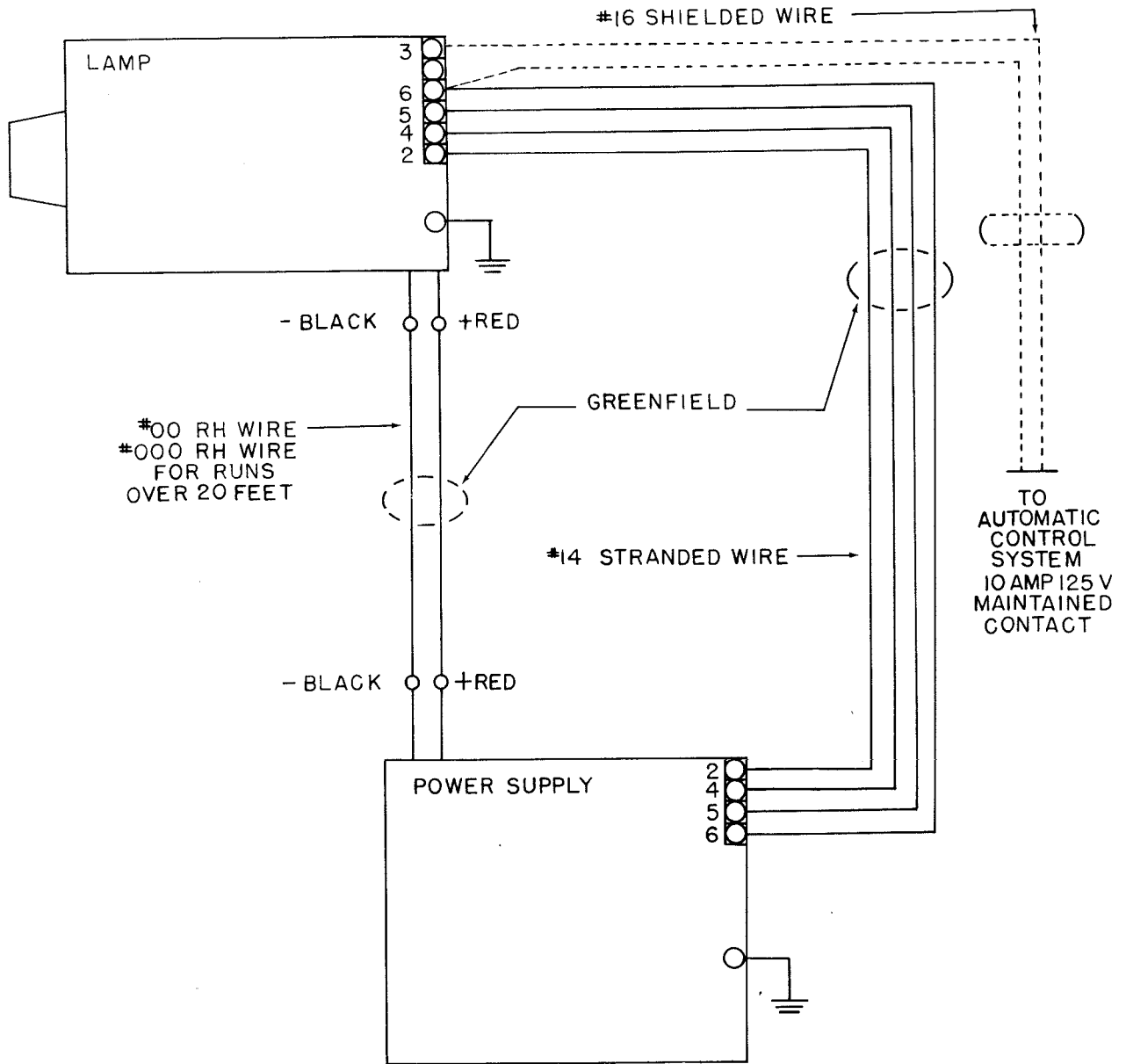

LAMPHOUSE ALIGNMENT

ONE ALIGNING KIT consisting of an aligning cord, aperture plate, dummy lens and weight is supplied with each pair of xenon lamps to provide an accurate and reliable method of optical alignment of the lamphouse to the projector mechanism. Good screen results can only be obtained by the careful use of the aligning kit.

PLACE THE LAMPHOUSE on the projector table and turn the door interlock switch actuator knob to its full open position to clear the side door latch system. Unlock the side door and turn the latch bar clockwise, to its vertical position, to release the door.

INSTALL THE REFLECTOR in the frame by placing the front edge of the reflector behind the retaining clips and secure in position by moving the reflector clamp at the top of the frame into the locked position. It is best to wear clean cotton gloves to avoid marking the reflector with fingerprints when installing the reflector. The reflector must be in place before installing the xenon bulb. Make certain the reflector is installed with the word "Top" at the top of the reflector frame and the reflector is secure against the reflector retaining clips.

POSITION THE LAMPHOUSE on the table so the center of the reflector will be as near 34 inches from the projector film line as the projector design will permit.

IN PREPARATION for optical alignment, bolt the lamphouse temporarily to the lamphouse base with the 5/16-18 cap screws (in small cloth bag) shipped with the lamp.

REMOVE the 1/4-20 screw in the douser and pass the cord through the small hole in the rear access panel of the lamphouse located at the approximate center of the nameplate in the black band along the bottom of the plate.

OPEN THE FIRE SHUTTER and fasten it so it cannot fall shut. This can be done with a rubber band or paper clip. Turn the projector mechanism by hand to clear the shutter blades.

CLOSE THE DOUSER and pass the cord through the hole in the center of the douser and into the projector mechanism.

REMOVE THE PROJECTION LENS and pull the cord through the opening. Pass the cord through the dummy lens and tie the cord to the weight. Position the test aperture in the projector. The test aperture is held in place by closing the projector film gate.

MOST PROJECTOR BASES have adjustable lamphouse tables so the lamp can be brought into optical alignment with the projector mechanism. If the lamphouse table is not adjustable, use shims or washers at the front, rear or at both ends of the lamphouse to obtain optical alignment with the projector lens system.

ALIGN THE LAMPHOUSE in relation to the projector so the cord passes through the center of the hole in the test aperture and douser.

REMOVE THE CORD, and associated fixtures and replace the 1/4-20 screw in the douser. Install the safety glass and casting on the front of the lamphouse. Use the three #8-32 x 3/8" binding head screws and lock-washers supplied, to secure the glass and casting in position. Turn the focus control knob to move the bulb pedestal to its extreme forward position to prevent the bulb safety shield from contacting the reflector.

INSTALL THE XENON BULB according to the instructions presented under "Xenon Bulb Installation" in this instruction manual. Observing all safety procedures, remove the protective plastic cover from the bulb. Adjust the focus control knob to move the focus adjustment shaft to the approximate center of its travel.

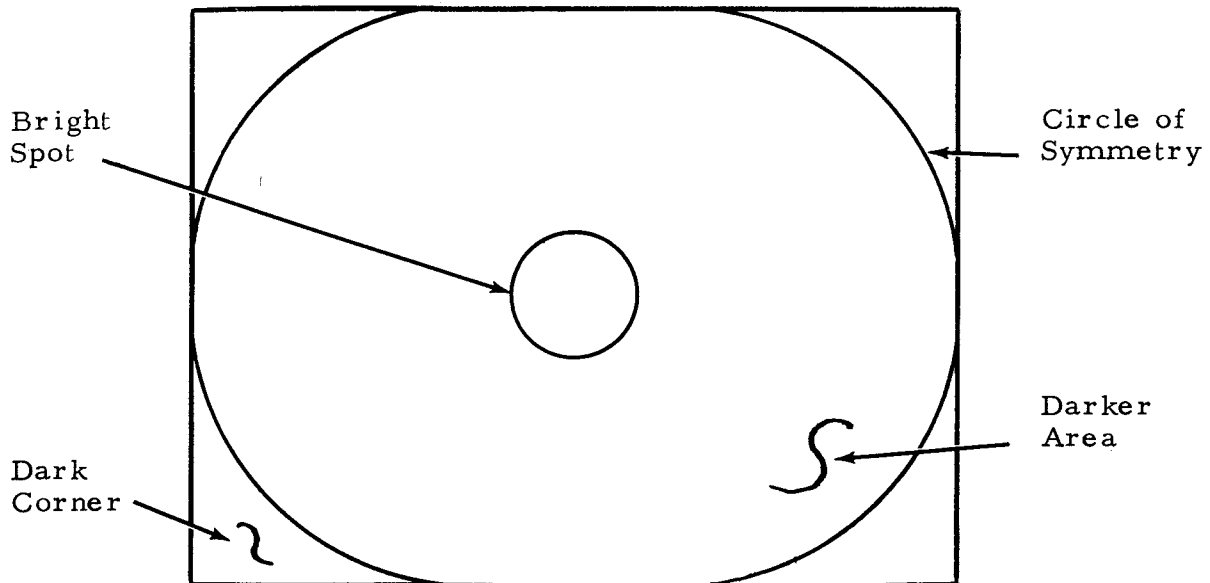

CLOSE AND LATCH the side door to secure the door in the closed position. Screw in finger-tight, the door interlock actuator knob to engage the door interlock switch, then lock the door.

TURN ON THE PROJECTOR and ignite the bulb as described under "OPERATION" in this manual. Adjust the lamp focus control until a bright spot appears on the screen. The bright spot at this point does not need to be in the center of the screen but it must be relatively symmetrical. If it is not symmetrical adjust the horizontal and vertical adjustment controls. It is very important that a symmetrical bright spot is obtained.

IF THE BRIGHT SPOT does not appear in the center of the screen move the projection table to center the spot. Once the spot is centered on the screen then the circle of symmetry should also be centered on the screen.

CAUTION: DO NOT LEAVE BRIGHT SPOT ON TOO LONG AS THE HEAT GENERATED BY THE XENON BULB COULD CRACK THE PROJECTION LENS.

THE LAMPHOUSE can now be firmly located and the focus adjusting knob adjusted until the proper light distribution is obtained on the screen.

XENON BULB INSTALLATION
OSRAM 4000 WATT(135A.)
Strong #81339

CAUTION: OBSERVE ALL SAFETY PRECAUTIONS WHEN WORKING WITH THE XENON BULB. Be sure the bulb is in its plastic case before handling. Wear clean cotton gloves when handling the bulb to prevent marking the bulb with fingerprints.

REMOVE THE HINGE PIN taped to the bulb support casting in the front of the lamphouse.

BENCH ASSEMBLE the adapter parts and bulb as outlined below.

- (a) Place the flanged teflon bearing on the anode (pos.) stud with the flat side of the bearing against the bulb.
- (b) Place the bulb adapter casting over the flange on the teflon bearing.
- (c) Slip the flat teflon washer over the stud on the bulb, up against the adapter casting.
- (d) Install the collar and secure to the bulb stem with the set screw.
- (e) Slip the piece of silastic rubber tubing over the anode (Pos.) lead.

SLIP THE CATHODE LEAD and adapter assembly over the cathode (negative) stem of the bulb. At this time tighten the set screw just enough to hold the lead assembly to the bulb. Assemble so both the anode and cathode leads come off the same side of the bulb. Position the bulb adapter casting so that when the bulb is placed in the lamphouse, both leads extend towards the side door of the lamphouse.

PLACE THE XENON BULB AND ADAPTERS in the lamphouse (with plastic shell over the bulb) with the cathode (negative) end in the "V" of the insulated support block behind the reflector frame. Position the anode (positive) end of the bulb adapter over the front support casting and insert and tighten the hinge pin through the hole marked for 4 KW operation. It is necessary to use the correct hole to provide the amount of movement required to properly focus the bulb in relation to the reflector. The bulb must float and pivot on the support to allow for movement by the vertical and horizontal adjustment controls. Both leads from the bulb should extend towards the side door of the lamphouse.

CONNECT THE ANODE (positive) lead from the bulb, to the feed-through connector located on the base casting. Remove one nut, lockwasher and flat washer. Place the positive terminal against the nut remaining on the connector and replace the flat washer, lockwasher and nut in that order. Tighten securely to prevent the connection from overheating. Lay the lead so it does not shadow the reflected light any more than absolutely necessary.

REMOVE THE HEX HEAD BOLT, lockwasher and flat washer from the negative terminal of the igniter, located directly behind the reflector frame. Run the cathode lead from the bulb, out toward the side door and form the lead to curve up to the negative terminal on the igniter. Try to position the lead so that it does not touch any structural part of the lamphouse. Replace the flat washer, lockwasher and hex head bolt, in that order, on the negative terminal and tighten securely. Tighten the set screw holding the negative lead and adapter to the stem of the bulb.

IF THE BULB MANUFACTURER recommends that the bulb be rotated after (500) hours of operation, loosen the set screw in the cathode (negative) adapter and remove the anode (positive) connection at the feed-through connector at the front of the lamphouse. Rotate the bulb 180°, form the anode lead to the feed-through connector and tighten securely. Then form the cathode lead and tighten the set screw in the adapter. It should not be necessary to loosen or remove the cathode connection at the igniter.

DO NOT EXCEED the bulb manufacturer's recommended initial starting current or maximum current for aged bulbs. The recommended initial current is 80-85% of the maximum rated current.

A XENON BULB can be focused to a small hot spot at the aperture or projection lens and if this is done the film may be damaged or the projection lens broken. The projector must be running whenever the bulb is ignited and the douser is open. Adjust the focus of the bulb in relation to the reflector to obtain a flat field, with the corners of the screen evenly lighted. It is possible to obtain nearly 100% coverage. Check the film for damage or high temperature and if running hot, reduce the current at the bulb or adjust the focus for a flatter field.

WHEN A NEW BULB is installed it is necessary to reduce the current by resetting the transformer/rectifier coarse tap leads to tap "A" and the dial switches to position #1. (All three switches must be on the same number.) This is necessary because each bulb operates at a slightly different voltage due to manufacturing tolerances. The current can now be adjusted to operate within the specified range.

RETURN BULBS on which a warranty claim is being made in original shipping carton with protective plastic cover over bulb. Include the following information: number of hours bulb was used, amperage bulb was burned, date bulb was installed, date bulb was removed and reason for removing.

BULB INSTALLATION PROCEDURES

OSRAM 3000 WATT (100A.) Strong #81344

Follow the same assembly and installation procedures as outlined for the Osram 4000 Watt, except as follows:

1. Cut the anode (positive) lead on the bulb so it extends 4" from the bulb stem.
 2. Attach the wire connector to the 4" lead from the bulb.
 3. Insert the rubber covered anode extension into the cable connector (step 2) and tighten securely both set screws in the connector.
 4. Make the lamphouse connections the same as specified for the 4000 Watt.
-

HANOVIA 4000 WATT (150A.)

Follow the same assembly and installation procedures as specified for the Osram 4000 watt bulb.

DUROTEST 150 AMPERE Strong #81918

This bulb does not require any adapters or lead extensions to permit mounting and use in this lamphouse. The following changes do have to be made in the lamphouse.

1. Due to the larger diameter of the cathode (neg.) end of the Durotest bulb, it is necessary to remove the insulated guide block #81135 and the metal spacer #81336 from the cathode support casting.
 2. The metal spacer is NOT required for the Durotest bulb. Fasten the insulated guide block back on the cathode support casting. This will lower the cathode end of the bulb to the optical centerline of the reflector.
 3. Remove the small sheet metal air deflector #81351 from the anode air duct at the front of the lamphouse. It cannot be used with this bulb.
 4. Attach the bulb to the anode support casting with the #81129 hinge pin and secure the leads from the bulb to the igniter and feed-through connector as instructed for the Osram 4 KW bulb. Make certain all electrical connections are tight.
-

AUTOMATIC SYSTEMS

INSTALLATION:

To install the lamp in an automatic system follow the same instructions presented for manual type operation. Two 16 AWG wires (not supplied by manufacturer) must be installed to permit operation by the automatic system (See installation diagram). The wires must be shielded to prevent interference from feeding into the theatre sound system.

OPERATION:

The operation of the lamp in an automatic system is the same as outlined in the manual with the exception that the "Auto-Man." switch, must be placed in the "Auto." position. When the lamp "ON-OFF" switch is turned on the lamp will be ready to operate from the remote station. The bulb seal cooling blower will operate until the main A. C. line switch or the lamp "ON-OFF" switch is placed in the "OFF" position.

Attach the automation ignition cue or tab on the film far enough in advance of the projection cue, to permit a few ignition pulses. The ignition pulse is timed at approximately one second on and two to three seconds off. This pulse is controlled by the timer circuit in the igniter.

TROUBLE CHART:

To trouble shoot the lamp when installed in an automated system, place the "Auto-Man." switch in the "Man." position. The lamp will then operate in the normal mode as described under "Trouble Chart".

To restore the lamp to a remote operation, place the "Auto-Man." switch in the "Auto" position.

OPERATION

REMOVE THE PROTECTIVE PLASTIC COVER from the xenon bulb. Do not ignite the lamp with the cover on the bulb. Latch and lock the side door of the lamphouse. The latch bar must be turned counter-clockwise to the horizontal position. Turn the door interlock actuator knob in finger tight, to its closed position to actuate the door interlock switch.

THE PROJECTION BOOTH exhaust system must be operating to close the lamphouse exhaust air flow interlock switch.

CLOSE THE LAMPHOUSE DOUSER and place the Auto-Man. switch in the "Man. " position.

TURN ON MAIN LINE SWITCH to energize the power supply, the red indicator on the lamphouse will glow.

PLACE LAMP ON-OFF SWITCH in the "ON" position. The cooling blower for the bulb seal will run and close the air vane interlock switch. The amber indicator lamp will glow, indicating all interlock switches are closed.

IGNITE THE LAMP by pressing the ignite button and hold until the bulb ignites. The recommended initial current range is 80-85% of the maximum current stated by the manufacturer. The lamp current should never exceed the maximum rating of the xenon bulb.

OPEN THE DOUSER with the projector running and adjust the horizontal and vertical control knobs to center the light on the screen. Adjust the focus control knob to obtain the desired light distribution for 35 or 70mm. When the desired light distribution has been achieved the control knobs may be removed and kept in a safe place to prevent the possibility of anyone accidentally changing the adjustments.

WAIT A FEW MINUTES until the current or arc stabilizes, then adjust the power supply, (see power supply manual), to obtain the desired current as indicated on the lamp ammeter.

TO MAINTAIN SCREEN LIGHT BALANCE it may be necessary to operate one lamp at a little higher current than the other. Due to manufacturing tolerances and to normal aging, increase the current of the lamp giving low light output, or adjust the current of both lamps.

TO EXTINGUISH THE ARC, push the lamp power switch to the "OFF" position.

ARC STABILIZING MAGNET ADJUSTMENT

THE ARC STABILIZING MAGNET is located on the lamphouse base casting in back of the reflector frame.

THIS MAGNET is preset at the factory and should not require adjustment.

IF IT SHOULD BECOME NECESSARY to adjust the magnet, the following procedure must be followed. Observe all safety procedures when working inside the lamp.

THE NORMAL ARC, when viewed thru the arc viewing port, will appear as in Figure A. When this condition exists, the magnet is set properly.

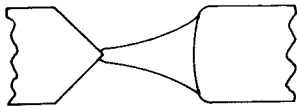

FIGURE A

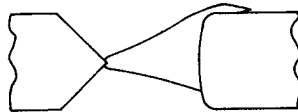

FIGURE B

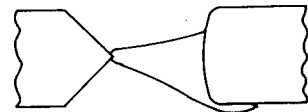

FIGURE C

FIGURE B shows the position of the arc when the magnet is too low. To correct this condition the magnet must be raised (moved toward the bulb). To do this, loosen one of the 2 screws in the slot, about 3 turns. Loosen the other screw in the slot, just enough so that the magnet assembly can be moved upward about 1/8 inch. After adjusting the magnet, tighten both screws. Repeat this step until the arc looks like Fig. A.

FIGURE C shows the position of the arc when the magnet is too high. To correct this condition the magnet must be lowered. To do this loosen the magnet as described in above paragraph and lower magnet 1/8 inch. After adjusting the magnet, tighten both screws. Repeat this step until the arc looks like Fig. A.

THE MAGNET must always be installed with the longest portion of the magnet facing the bulb, and with the South (S) Pole pointing to the side door.

IN NEW EQUIPMENT the magnet normally is in the center of the adjustment range. Changes in magnet position must only be made when the arc is burning improperly as shown in Figure B and C.

WHEN A NEW MAGNET is installed it should be set in the center of the adjustment range and then adjusted if necessary to obtain results shown in Figure A.

MAINTENANCE

THE XENON LAMP requires very little maintenance to keep it in good working order.

THE REFLECTOR should be cleaned with a clean soft dry cloth every two weeks. Follow the detailed cleaning instructions enclosed with the reflector. Care should be taken when handling reflector so as not to finger-mark the coated surface.

IF THE REFLECTOR is removed for cleaning or for any other purpose, check to see that the bulb is adjusted for maximum light output after replacing the reflector and installed with the stamp "TOP" at the top of the reflector frame.

CHECK ALL ELECTRICAL CONNECTIONS periodically for tightness. Particularly the D.C. connections on the shunt inside the rear access panel and the bulb connections at the igniter, and at the positive feed-through connector.

OCCASIONALLY THE BULB should be checked for presence of foreign material on the envelope. Any dirt or other foreign material should be removed promptly. CAUTION: Observe all safety procedures when working around the bulb.

THE INSIDE OF THE LAMPHOUSE and the fan blades should be cleaned periodically, depending on the dust conditions at each installation. Make sure the blower inlet screen on the front of the lamphouse is clean and free of any obstruction.

BUG SCREENS in the rear access panel just below the nameplate and inside the lamphouse behind the magnet, must be kept clean at all times to permit a free air flow to cool the back of the lamphouse and rear surface of the reflector.

SCHEMATIC DIAGRAM

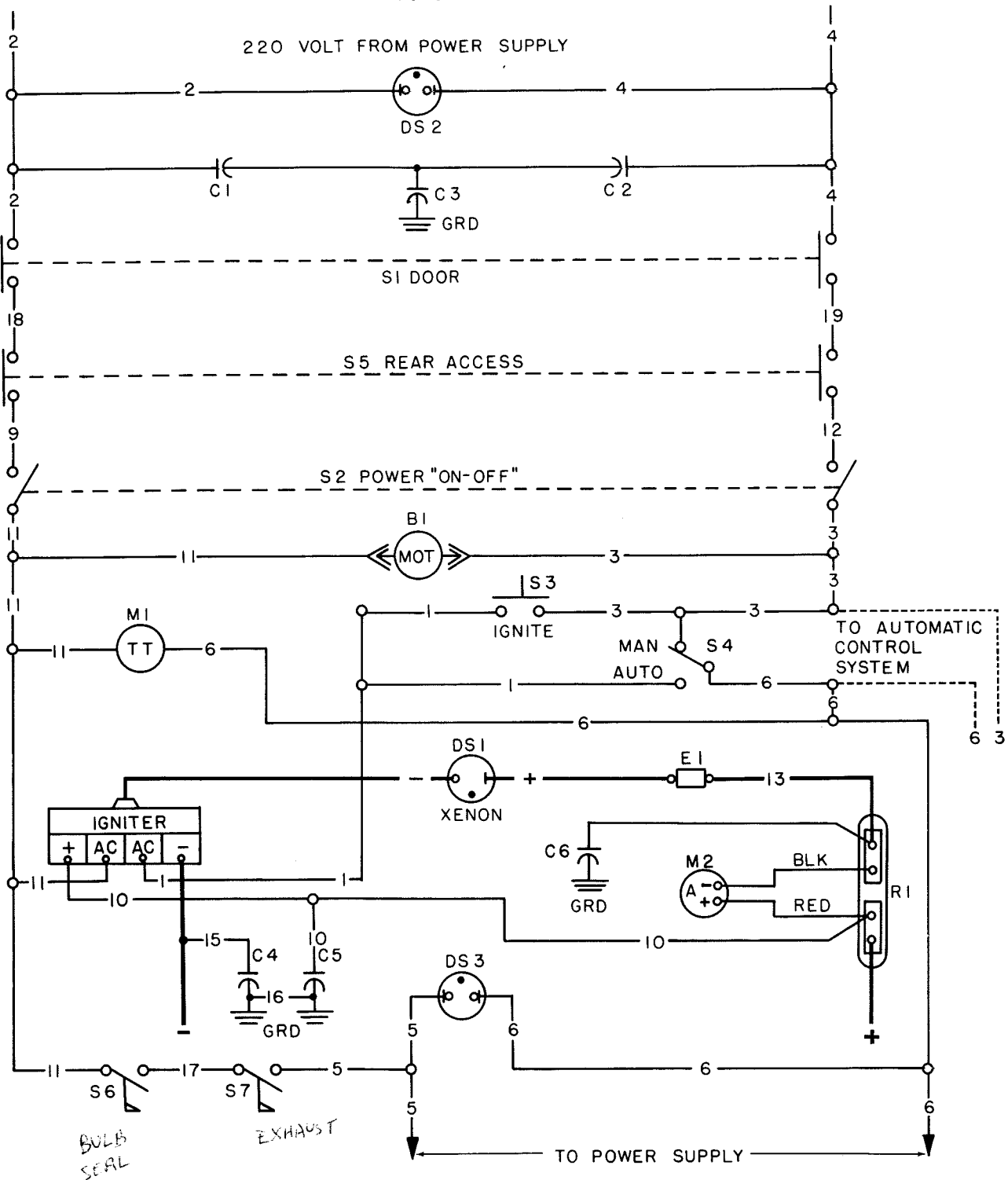

PARTS LIST
SCHEMATIC DIAGRAM

<u>Reference Designation</u>	<u>Part No.</u>	<u>Description</u>
-	81112-A	Igniter (50/60 Hz)
B1	81272	Blower Fan (bulb seal) 50/60 Hz
-	81916	Lead Cord & Plug for 81272 (B1)
C1 & C2	76132	Capacitor .005 MFD/600 V.DC (R. F. Suppression)
C3	76133	Capacitor .01 MFD/400 V.DC (R. F. Suppression)
C4 & C5	76323	Capacitor 8 MFD/150 V. AC (DC By-Pass)
C6	81921	Capacitor .01 MFD/500 or 1000 V.DC
DS1	81339	Xenon Bulb (Osram 4000 W.)
DS2	81278-1	Indicator Lamp (Red)
DS3	81278-2	Indicator Lamp (Amber)
E1	81920	Feed-Thru Insulator and Lead #13
M1	81289	Elapsed Time Meter 230V. AC, 60 Hz
-	81374	Elapsed Time Meter 230V. AC, 50 Hz
M2	81280	Ammeter D. C.
R1	81247	Shunt
S1	80168	Switch, Interlock, Side Door
S2	81275	Switch, Power (ON-OFF)
S3	81277	Switch, Ignite
S4	81276	Switch, "Man-Auto"
S5	80168	Switch, Interlock; Rear Access Cover
S6	75187	Switch, Air Flow (Bulb seal)
S7	75187	Switch, Air Flow (Exhaust)

TROUBLE CHART

NORMAL OPERATION:

The projection booth exhaust system must be operating to close the air vane interlock switch in the lamphouse exhaust stack.

When the switch in the main A.C. line to the power supply is placed in the "ON" position, the "RED" indicator light on the lamphouse will glow and signify that the 220 V. A. C. control circuit to the lamphouse is energized.

The side door interlock switch and the rear access panel interlock switch must be closed to complete the circuit to the lamphouse "ON-OFF" switch.

Place the lamphouse "Mode" switch in the "Man." position. When the lamp "ON-OFF" switch is turned "ON", the running time meter will indicate elapsed time and the bulb seal cooling blower will operate closing its air vane interlock switch. The Amber indicating lamp will glow and show that all the lamphouse safety interlock switches are closed and the A. C. control circuit through the lamphouse is energized.

The line contactor in the power supply will close and the rectifier cooling fan (if so equipped) will run. There will be a faint clicking sound coming from the back of the lamphouse. This is the igniter control relay clicking as its contacts open and close. This clicking will continue at 2-3 second intervals, as long as the power switch is on and the bulb not ignited.

The ignite button is then pushed in and held in this position until the bulb lights. The relay will stop clicking as soon as the bulb lights. There will be a distinct buzzing sound, at the moment the bulb ignites. This is caused by the spark gap in the igniter, and the high voltage arcing in the bulb.

IGNITER NORMAL OPERATION:

When the "ON-OFF" switch on the lamp is turned on, the power supply is energized supplying a high D. C. voltage to the igniter. This voltage will range from 100 to 120 V. DC, no load, depending on the setting of the power supply. This voltage is necessary to ignite the xenon bulb.

The igniter has a polarity sensing device that determines polarity is correct before energizing the voltage level sensor and timer circuit.

This voltage is then applied to a transistorized timer circuit in the igniter, which actuates a relay to turn the R. F. pulse section of the igniter on and off. This timed circuit is on 1 second, off 2-3 seconds. The relay contacts are connected in series with the lamp ignite button so that, although there is sufficient D. C. voltage, the R. F. pulse circuit cannot be energized until the lamphouse ignite button is actuated.

When the bulb ignites, the D. C. voltage drops to normal bulb operating voltage. The voltage sensor in the igniter stops operation of the timer circuit and RF pulsing circuit, even though the ignite button may be held.

The igniter is equipped with a normally open push button switch to by-pass the timer circuit (Emergency Ignition Switch) if a fault is found to be in the timer circuit and should only be used for emergency operation until repairs can be made or a replacement igniter is available. This switch is located on the igniter behind the plug button on the rear access panel of the lamphouse. When this switch and the lamp ignite switch are simultaneously pressed, the xenon bulb should immediately ignite. DO NOT HOLD for more than one second before releasing both switches.

TROUBLE SHOOTING

BEFORE PROCEEDING with the following trouble shooting procedures, observe the following visual indications of trouble. Place the Auto-Man switch in the "MAN" position.

- (1) Red indicator light NOT "ON"
 - (a) Main A. C. line switch not "ON".
 - (b) Main A. C. line fuses open.
 - (c) Circuit breakers in power supply open.

- (2) Amber indicator light NOT "ON"
 - (a) Booth exhaust system not operating or lamphouse exhaust air vane switch not closed.
 - (b) Mode switch not in "MAN" position.
 - (c) Lamphouse ON-OFF switch not "ON".
 - (d) Rear access panel interlock switch not closed.
 - (e) Side door interlock switch not actuated.
 - (f) Bulb seal blower not operating or blower air vane switch not closed.

CAUTION: The lamphouse control circuit operates on 220V. A. C. and a shock hazard exists when voltage readings are being taken inside the lamphouse. Many A. C. voltage readings can be made at the terminal block located behind the rear access panel.

<u>TROUBLE</u>	<u>PROBABLE CAUSE</u>	<u>TEST</u>	<u>REMEDY</u>
Bulb fails to ignite (Red neon light not on.)	AC power not on to lamphouse		See power supply manual.
Bulb fails to ignite. (Amber neon light not on.)	Door interlock switch not actuated.	Check for open lamphouse door.	Shut & secure door. Tighten actuator knob.
	Faulty door interlock switch.	Check for voltage between Wire #18 & #19.	If voltage is not measured, check loose wiring or replace interlock switch.

<u>TROUBLE</u>	<u>PROBABLE CAUSE</u>	<u>TEST</u>	<u>REMEDY</u>
Cont'd.	Exhaust air vane in lamp not actuated (pulled-up).	Visually check exhaust air vane switch S-7 to see if it is actuated.	Turn on main exhaust blower. Increase air velocity if necessary. (See Exhaust Systems Installation in this manual.)
	Faulty bulb seal blower.	With lamp power on check for bulb seal blower operation.	Check for loose or faulty wiring to bulb seal blower motor. If none, replace blower motor.
	Defective or inoperative switch S-6 (bulb seal) or switch S-7 (exhaust).	Check voltage between terminals 6-17.	If voltage is NOT indicated, S-6 (seal) faulty or inoperative. If voltage IS indicated then S-7 (exhaust) faulty or inoperative.
	Faulty "On-Off" switch (lamp).	Check voltage between wire #11 & 3.	Check for loose wiring. Replace switch if voltage is not measured.
	Rear access panel interlock switch not closed.	Secure rear panel.	Adjust switch if not closing.
	Faulty rear panel switch.	Check voltage between wires 9 and 12 at switch.	If voltage is not indicated, replace switch.

<u>TROUBLE</u>	<u>PROBABLE CAUSE</u>	<u>TEST</u>	<u>REMEDY</u>
Bulb fails to ignite (amber and red neon lights on).	Wrong DC polarity to lamp.	Check polarity.	Connect properly.
	Faulty bulb.	Visually check for cracked anode or cathode.	Replace.
CAUTION: CHECK POLARITY before proceeding with following test.			
	Defective relay or timer circuit in igniter	Remove plug button from back of lamp. Press by-pass switch on igniter simultaneously with ignite button.	If bulb ignites, turn off all power to lamp. Remove access cover. Remove igniter cover and replace relay or igniter.
	Low voltage.	Defeat rear access interlock switch and measure DC voltage at terminals 10 and 15 on capacitor C4, C5 inside rear access panel with on-off switch on lamp turned "On". Should measure minimum 90 volts.	If voltage is less than 90 volts. check power supply (See power supply manual.)
	Faulty remote-contact.	With power "Off" place in Auto-position, close remote control contact and check continuity between 3 & 6.	If continuity is not read, repair/replace contact.
	Power supply.	See power supply manual.	
	Defective igniter.		Replace.

<u>TROUBLE</u>	<u>PROBABLE CAUSE</u>	<u>TEST</u>	<u>REMEDY</u>
Buzzing in theatre sound system only at time of ignition for 1 second.	Defective capacitors C4 & C5)	Check capacitors with capacitor tester if available.	Replace defective capacitors(See C4 & C5 on schematic diagram.)
Popping in theatre sound system when bulb is ignited.	Defective capacitor on R. F. suppression assy.	Remove and check capacitors with capacitor tester if available.	Replace R. F. suppression assy. or faulty capacitors.
"Man-Auto" switch in "Auto" position but operating in "Man" mode.	Faulty "Auto-Man" switch.	With power off. measure continuity between wires #3 & #6 with switch in "Man" position and 1&6 in auto. position.	If zero resistance not read, replace "Auto-Man"switch.
High voltage arc seen in ammeter during ignition.	Defective capacitor (C6)		Replace defective capacitor (C6).
Reduced light.	Bulb aging.		Increase current (see Operation section of power supply manual).
Excessive light flicker.	Faulty bulb	Visual inspect for cracked anode or cathode.	Replace.
	Power supply.		See power supply manual.

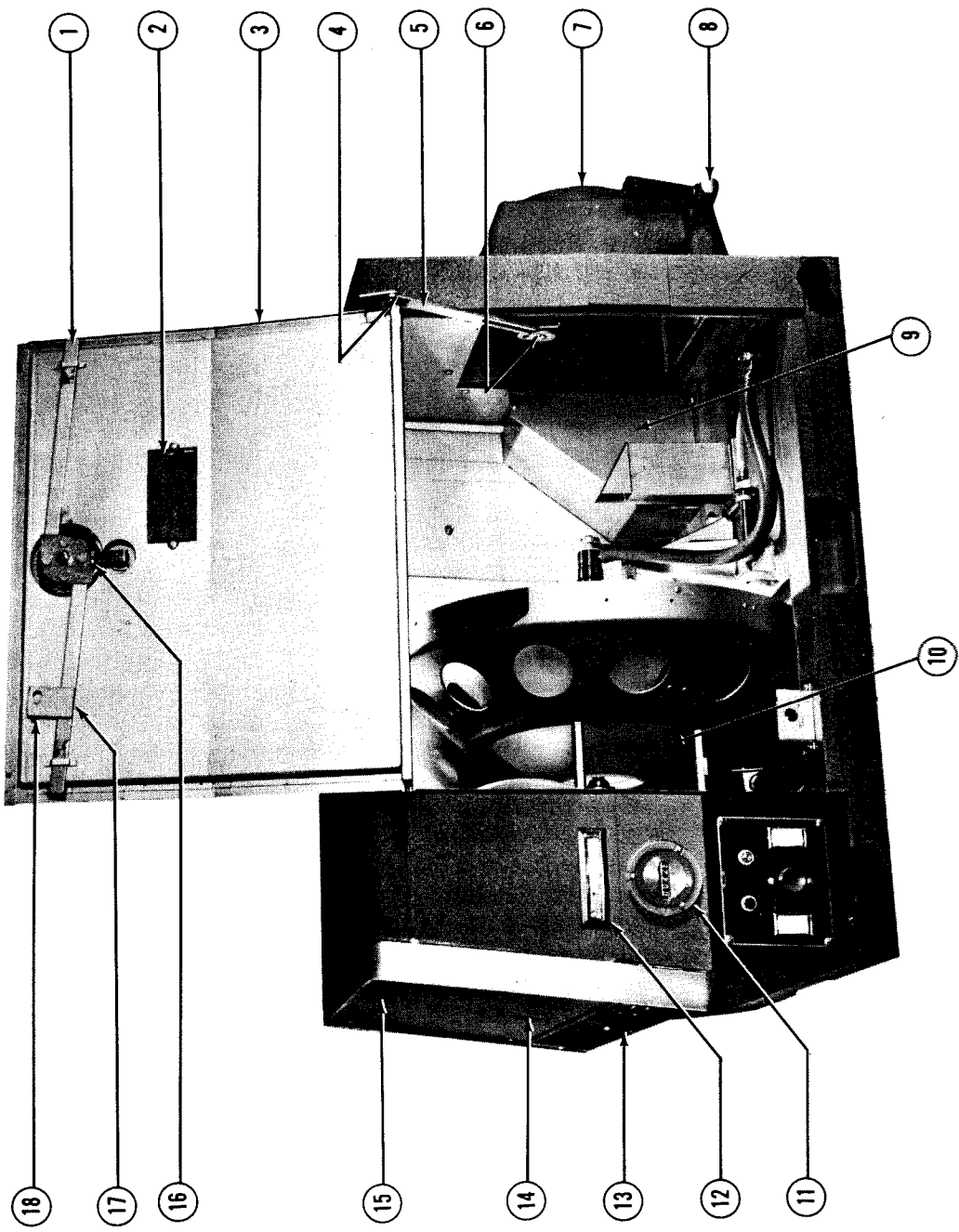

FIGURE I

FIGURE 1

<u>Item</u>	<u>Part No.</u>	<u>Description</u>
1	81361	Latch Bar, Front
2	81146	Window Frame
	81264	Gasket
	81189	Screen, Coarse
	48189	Screen, Fine
	11042	Glass
	19007	Clip, Retaining
	1304	Screw #8-32 x 5/16" Bd. Hd.
	891-A	Lockwasher #8
3	81891	Door Weldment
4	81365	Bearing
	1304	Screw #8-32 x 5/16" Bd. Hd.
5	81364	Slide Bar
6	81365	Bearing
	81376	Washer
	1311	Screw #8-32 x 3/8 Bd. Hd.
7	81355	Safety Glass, Douser
	81354	Retainer, Safety Glass
	1311	Screw, #8-32 x 3/8" Bd. Hd.
	1342	Lockwasher #8
8	81992	Douser & Nose Assy.
	51509	Handle
	64540	Stud, Handle
	807	Nut 5/16-18 Hex
	90266	Hub, Handle
	81149	Cross Shaft
	81187	Spring, Torsion
	81148	Douser Plate
	90134	Shoulder Screw
	721	Set Screw #10-24 x 3/16" Allen Hd.
	81234	Bumper Pad
	81147A	Housing, Douser
	1566	Screw #10-24 x 5/16" Bd. Hd.
9	81933	Housing, Fan
	1566	Screw #10-24 x 5/16" Bd. Hd.
	685	Screw 1/4-20 x 3/8" Hex Hd.
	881	Lockwasher 1/4" Split Ring
	852	Flat Washer 1/4"
	81913	Air Inlet Screen, Bulb Seal
10	4271	Reflector (Spec 271)
11	81289	Elapsed Time Meter (60 Hz.)
	81374	Elapsed Time Meter (50 Hz.)
	1515	Screw #4-40 x 1/4" Rd. Hd.

<u>Item</u>	<u>Part No.</u>	<u>Description</u>
12	81280	Ammeter
13	81889	Access Cover, Rear
	1304	Screw #8-32 x 5/16" Bd. Hd.
14	57275	Plub Button
15	80168	Switch, Interlock S5 (inside cover)
	1741	Lock Washer 7/16" Internal
16	81358	Latch & Lock, Side Door
17	81897	Latch Bar, Rear
18	81896	Actuator and Knob (Door Interlock S1)
	81367	Actuator Screw
	80193	Knob & Set Screw

Parts Not Shown

81966	Exhaust Stack
1355	Screw #8-32 x 5/16 Type "F"
891A	Lock Washer #8 Shakeproof
75187	Switch, Exhaust Interlock (S7)
81914	Air Vane Assy.
81304	Cover, Switch
1414	Screw #6 x 3/16 Type "Z"
48316	Grommet
81321	Heat Shield (mounts on Refl. Studs #81315)

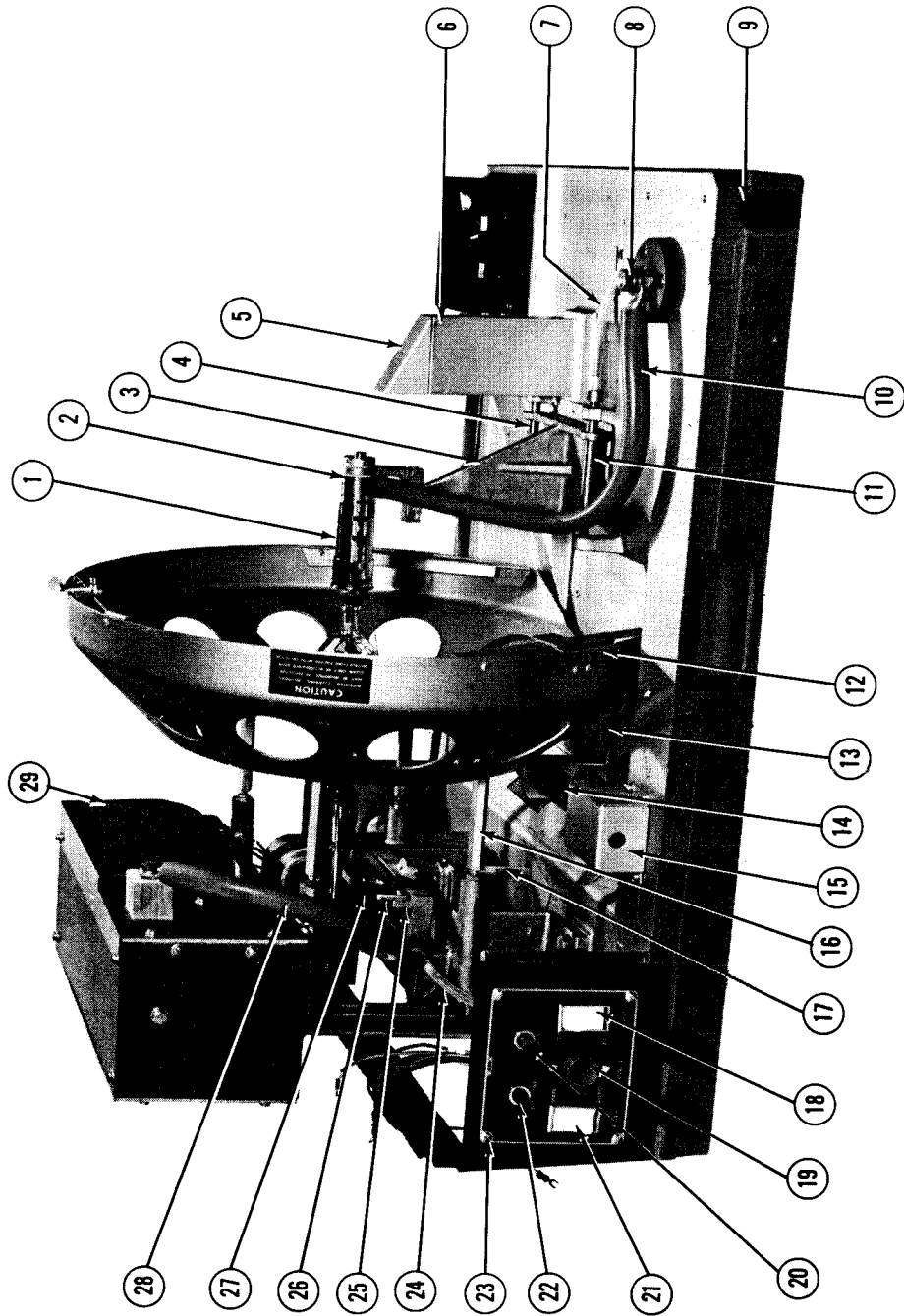

FIGURE 2

FIGURE 2

<u>Item</u>	<u>Part No.</u>	<u>Description</u>
1	81339	Xenon Bulb (Osram 4 KW, 135 Amp.) (DS1)
2	81342	Flanged Bearing
	81338	Adapter, Bulb
	81343	Washer, Flat
	81341	Collar, Retaining
	1598	Set Screw #6-32 x 3/16 Hdless
3	81122	Support, Bulb
	81129	Hinge Pin
4	81124	Shaft, Outrider
5	81351	Air Deflector
6	81140	Air Duct, Anode
7	81997	Flexible Shaft, Focus Adj. <i>NEW # 71938000</i>
	46138	Retaining Ring 1/4" "E"
	81941	Cover Plate, Flexible Shaft
8	81920	Feed-Through Connector (See Fig. 3, Item 5)
	81919	Lead Wire and Stud (Pos.)
	1678	Nut 3/8-16 Hex
	839	Flat Washer 3/8"
	878-A	Lock Washer 3/8" Split Ring
	81301	Insulator Body
	385	Screw #10-24 x 1/2" Fil. Hd.
	885	Lock Washer #10 Internal
	831	Washer #10 Flat
9	80193	Knob & Set Screw
10	81340	Insulation, Bulb Anode Lead
11	81127	Shaft, Focus
	76157	Retaining Ring "E" - 3/8"
12	81909	Reflector Frame
13	81314	Support Bracket, Magnet
	1304	Screw #8-32 x 5/16" Bd. Hd.
	891-A	Lock Washer #8
14	M15315	Magnet
	81137	Retaining Block, Magnet
	1710	Screw #8-32 x 1/4" Hex Hd.
	781	Set Screw #8-32 x 1/4" Allen Hd.
15	81893	Cover, Door Interlock
	254	Screw #8-32 x 1/4" Fil. Hd.
	891-A	Lock Washer #8
	80168	Switch, Door Interlock (SI)
	81372	Grommet, Wire
16	81315	Stud, Reflector Frame
	81318	Shoulder Screw, Hex Hd.
	1573	Nut 1/4-20 Hex

<u>Item</u>	<u>Part No.</u>	<u>Description</u>
16 (contd)	81321	Shield, Heat (not shown)
17	81997	Flexible Shaft, Vertical Adj.
	714	Set Screw #8-32 x 1/8"
	81134	Adjustment Shaft, Vertical
	81940	Cover, Plate, Flexible Shaft
18	81275	Switch On-Off (Power) (S2)
19	81277	Switch, Ignition (S3)
20	81278-2	Indicator Lamp (Amber) (DS3)
21	81276	Switch "Auto-Man" (S4)
22	81278-1	Indicator Lamp (Red) (DS2)
23	81290	Mounting Plate
24	81998	Flexible Shaft, Horizontal Adj.
	81133	Adjustment Shaft, Horizontal
	81940	Cover Plate
25	81987	Support Cstg. Cathode
26	81336	Spacer, Guide Block
	315	Screw 1/4-20 x 1/2" Rd. Hd.
27	81135	Guide Block "V"
	315	Screw 1/4-20 x 1/2" Rd. Hd.
* (28	(81901)	Lead and Adapter, Cathode
	(721)	Set Screw #10-24 x 3/16 Allen Hd.)
29	81144-A	Heat Shield, Igniter

Parts Not Identified

81912	Harness Assy.
81943	Bug Screen - Behind Magnet
81202	Light Shield - Below Bug Screen

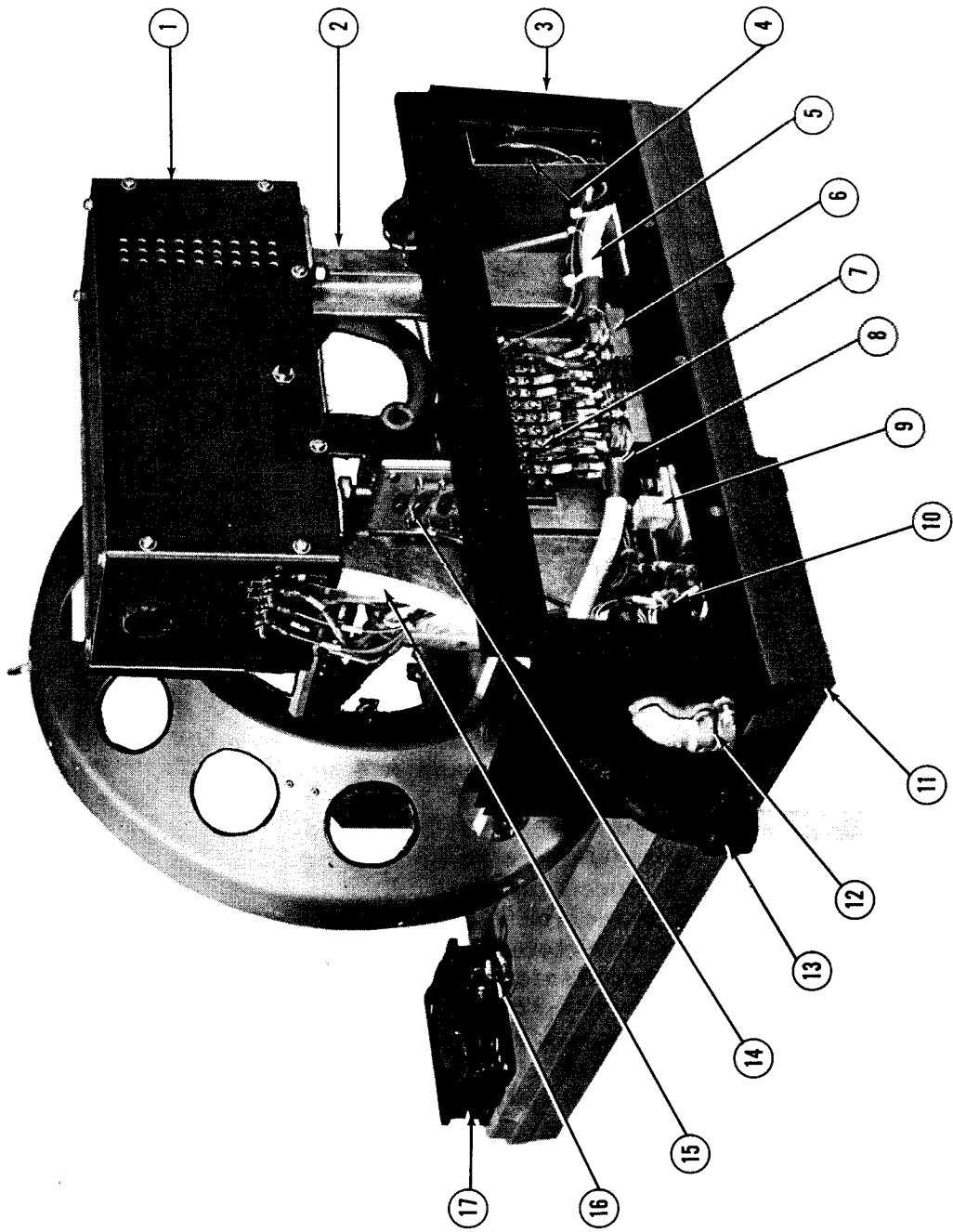

FIGURE 3

FIGURE 3

<u>Item</u>	<u>Part No.</u>	<u>Description</u>
1	81112-A	Igniter
	807	Nut 5/16-18 Hex
	877	Lock Washer 5/16 Split Ring
2	81123	Pedestal, Reflector & Igniter
	1419	Screw 5/16-18 x 3/4 Hex Hd.
	877	Lock Washer 5/16" Split Ring
3	81931	Panel Assembly - Welded
	237	Screw #8-32 x 3/8" Flat Hd.
4	81922	Cover Assy.
	1305	Screw #6-32 x 1/4" Bd. Hd.
5	81920	Pos. Lead & Insulator (See Fig. 2, Item 8)
	69125	Grommet
6	81247	Shunt (R1)
	385	Screw #10-24 x 1/2" Fil. Hd.
	875	Lock Washer #10
	81921	Capacitor Assy. (C-6)
7	81307	Terminal Block
	1593	Screw #10-32 x 1/2" Fil. Hd.
	886-A	Lock Washer #10
8	81976	Positive DC Lead
9	81274	Ground Terminal
	689	Screw 1/4-20 x 5/8" Hex Hd.
	876	Lock Washer 1/4" Split Ring
	835	Washer 1/4" Flat
10	76323	Capacitor, DC By-pass (C4 & C5)
	76208	Strap
	1304	Screw #8-32 x 5/16 Bd. Hd.
	886-A	Lock Washer #8 Split Ring
11	81928	Base & Duct Plates
12	81142	Angle Connector 1/2"
13	81143	Angle Connector 1-1/4"
14	76988	R. F. Suppression Assy.
	1304	Screw #8-32 x 5/16 Bd. Hd.
	830	Washer #8 Flat
	76132	Capacitor .005 MFD (C1 & C2)
	76133	Capacitor .01 MFD (C3)
	81141	Insulator
15	81977	Negative Lead, DC
16	75187	Switch, Blower Interlock (S6)
	1565	Screw #4-40 x 3/4" Rd. Hd.
	1343	Lock Washer #4 Internal
	81333	Bracket, Switch
	1305	Screw #6-32 x 1/4" Bd. Hd.

<u>Item</u>	<u>Part No.</u>	<u>Description</u>
16 (contd)	81903	Air Vane Assy.
17	81272 81873	Fan, Seal Blower (B1)
	1535	Screw #6-32 x 3/8" Allen Hd.
	892	Lock Washer #6 Internal
	81916	Cord and Plug
	49347	Grommet

PARTS LIST

All the prices are quoted f.o.b. Toledo and are subject to change without notice.

When ordering parts be sure to advise the serial numbers and the model of lamps in addition to the name of the parts wanted and how shipment is to be made.

There will be a minimum charge of ten dollars on any one invoice and a service charge sufficient to cover the cost of handling on all merchandise returned to us for credit.