

Film-Tech

The information contained in this Adobe Acrobat pdf file is provided at your own risk and good judgment.

These manuals are designed to facilitate the exchange of information related to cinema projection and film handling, with no warranties nor obligations from the authors, for qualified field service engineers.

If you are not a qualified technician, please make no adjustments to anything you may read about in these Adobe manual downloads.

www.film-tech.com

INSTRUCTION MANUAL

XENON POWER SUPPLY

Type 62-80000

208/230 V.AC Input



Rev. 1/97

**STRONG
INTERNATIONAL, INC.
4350 McKinley St.
Omaha, Nebraska 68112
402/453-4444**

PREFACE

THE STRONG INTERNATIONAL switching power supply Type 62-80000 is designed to operate a xenon bulb in all theatrical lighting applications for Strong lamphouses. This unit will operate all xenon bulbs rated from 1000 to 3000 watts throughout their full operating ranges (20-35 V.DC, 40-100 A.DC). The power requirement for this unit is 208/230 (200-240) V.AC, 30 amperes single or three phase, 50/60 Hertz.

INCOMING LINE POWER is transformed from 208/230 volts AC to a low voltage, high current DC output. The incoming AC line is filtered to eliminate noise and is then converted to DC. This DC voltage is switched on and off by a solid state switching circuit, and converted to a 25 kHz. square wave. The square wave is fed into output transformers to provide low voltage and high current. Rectifiers convert the 25 kHz. signal to DC, and the output is filtered to eliminate noise and ripple. Output to the xenon bulb is adjustable through use of (2) potentiometers (coarse and fine).

A STEPDOWN TRANSFORMER reduces the incoming line to 120 V.AC to power the lamphouse igniter and blower(s). A separate three ampere circuit breaker protects the control circuit in the event of a lamphouse component malfunction.

PROTECTIVE CIRCUITS include a high temperature limit switch, phase loss detection, and a brown-out circuit. The thermal switch will disable power supply operation if internal temperatures exceed 175° F. (80° C.). If one or more phase legs of the AC supply line is interrupted, the power supply will shut down. A drop in AC line voltage, reducing AC supply to inadequate levels, will also shut down the power supply.

A MULTI-PIN MS RECEPTACLE is standard on units supplied for use with Strong follow spot-lights. The receptacle (Part No. 62-70002) may be ordered as an option for motion picture or studio applications using Strong lamphouses equipped with the corresponding MS plug.

NOTICE

REFER ALL SERVICING of this unit to an authorized Strong International Equipment Dealer. The 62-80000 Switching Xenon Power Supply employs solid state circuitry requiring sophisticated diagnostic equipment not generally available to field service personnel. There are *no user serviceable* components in this unit.

INSTALLATION - OPERATION

CAUTION: High voltages exist inside the power supply enclosure. Remove *only* the (2) small access panels in the power supply cabinet for installation procedures. The input panel is located near the circuit breakers; the output on the opposite corner.

When positioning the power supply, allow several inches clearance around the power supply cabinet for unobstructed air flow. If the intake or outlet grilles are blocked, thermal switches will shut the unit off to prevent heat damage.

Connect the lamphouse leads to the output side of the power supply prior to connecting to AC power. Lamphouse to power supply connections are illustrated on the INTERCONNECTION DIAGRAM in the lamphouse instruction manual. Make certain the lamphouse ground lead is connected.

Power leads run to the unit must be of the correct size and type to conform to local codes. Shield in conduit as required. The power supply will not energize until the circuit breakers on the side of the cabinet are placed in the ON position.

Connect 208/230 V.AC three phase input to L1, L2, and L3. Connect single phase input to L1 and L3 only. Single phase neutral is not required for installation of this unit. Attach the ground lug to an adequate earth ground.

In areas using 440 V.AC three phase power (Europe, etc.), connect the unit for single phase operation only, using (1) phase line and a neutral. AC input as measured across contactor terminals L1 and L3 must not exceed 240 V.AC.

See the warranty information packed with the xenon bulb for correct operating current. *Do not, at any time, exceed the maximum current level specified by the bulb manufacturer.*

Current output to the bulb is adjustable through use of the (2) adjustment potentiometers. The potentiometers are normally located on the access plate used for lamphouse connection. On those power supplies furnished for motion picture applications, the FINE adjust potentiometer is normally in the upper position; the COARSE adjust potentiometer is below. If installed in a Strong Xenon Projection Console, the FINE adjust potentiometer may be remoted to the console control panel (customer option).

Spotlight power supplies have only the FINE adjustment potentiometer on the access cover plate. The COARSE adjustment potentiometer is located inside the cabinet on the lower right sector of the mother board (main printed circuit board). The COARSE adjustment potentiometer is labeled R46.

A second, two-terminal barrier strip located next to the DC output terminals is included in spotlight power supplies. Wires 7 & 8 (220 V.AC) terminate at this position, and supply voltage to lamphouse blowers in Gladiator spotlights. These wires are unused in Super Trouper and other spotlights, but are included to permit interchanging power supplies between Super Trouper and Gladiators. DC output must be re-set after changing a power supply from one system type to another. See the spotlight manual for current requirement.

Check the lamphouse ammeter upon the first bulb ignition, and adjust the FINE potentiometer to the desired bulb current. Rotate the potentiometer clockwise to increase current, or counterclockwise to reduce current. If the bulb current is too low at the highest setting of the FINE potentiometer, rotate the COARSE potentiometer slightly clockwise. If the bulb current is too high at the lowest setting of the FINE potentiometer, rotate the COARSE potentiometer slightly counterclockwise.

COARSE adjustment in the spotlight power supply requires the removal of the power supply cover, and should be performed by authorized personnel. The COARSE adjustment potentiometer R46 is concealed to discourage inexperienced operators from possibly overdriving the xenon bulb.

The stepdown transformer for the lamphouse control circuit is factory prewired. Terminals 2 & 4 supply 120 V.AC to the lamphouse. After completing the lamphouse interlock circuit, the 120 V.AC returns to the power supply on wires 5 & 6 to close the power supply contactor upon closure of the LAMP ON switch. The same circuit (5 & 6) energizes the lamphouse igniter.

The DC Pulse Igniter used in some Strong lamphouses does not require the AC voltage supplied on 5 & 6, but will be actuated from the high DC open circuit ("no load") voltage normally generated by the power supply. The DC voltage will fall to a lower sustaining level (20 - 35 V.DC) after the xenon bulb ignites, and the DC Pulse Igniter will cease operation when the DC voltage drops below 130 V.DC.

Terminals 3 & 6 are dry contact switching terminals for remote or automated ignition control. See the lamphouse manual Installation Diagram. *Do not* apply voltage to terminals 3 & 6.

MAINTENANCE

The power supply requires very little service to insure correct operation. Periodically check all electrical connections for tightness and condition, especially those in the DC circuit. Discolored terminals may indicate oxidation which will increase resistance.

Clean the ventilation inlet and outlet grilles on a regular basis to insure good air flow. Thermal switches mounted to the power supply will interrupt operation of the power supply in the event of overheating.

The blower motors are permanently lubricated. The 62-80000 power supply includes (2) blowers and *requires* operation of (1) fully functional blower for correct operation. In the event of a blower failure, the power supply may remain in service until the replacement blower is installed.

Service interruptions because of phase loss detection and brown-out protection require repairs to the AC supply line. To protect the equipment, phase loss detection and brown-out protection *cannot* be bypassed.

SWITCHING TYPE XENON POWER SUPPLY
Series 62-80000

<u>Item</u>	<u>Description</u>
1	Power Indicator Light, Red (PL-1)
2	Transformer (T6) Stepdown (220 V.AC Models) Isolation (115 V.AC Models)
3	Circuit Breaker, 3 Phase (CB2, 3, 4); 220 V.AC Models Circuit Breaker, 1 Phase (CB2, 3); 115 V.AC Models
4	Strain Relief, Power Cord *
5	AC Input Terminal Block
6	AC Power Cord *
7	Filter Board Assembly
8	Filter Capacitors (C13, 14)
9	Current Adjustment Potentiometer (Normally Mounted to Access Cover Plate; FINE, Upper; COARSE, Lower)
10	Mother Board
11	Torroidal Output Choke (L1, 2)
12	DC Output Terminal Block
13	Power Contactor (K1)
14	Lamphouse AC Control Circuit Terminal Block
15	MS Connector Assembly *

* Standard on Spotlight Models; Otherwise Optional

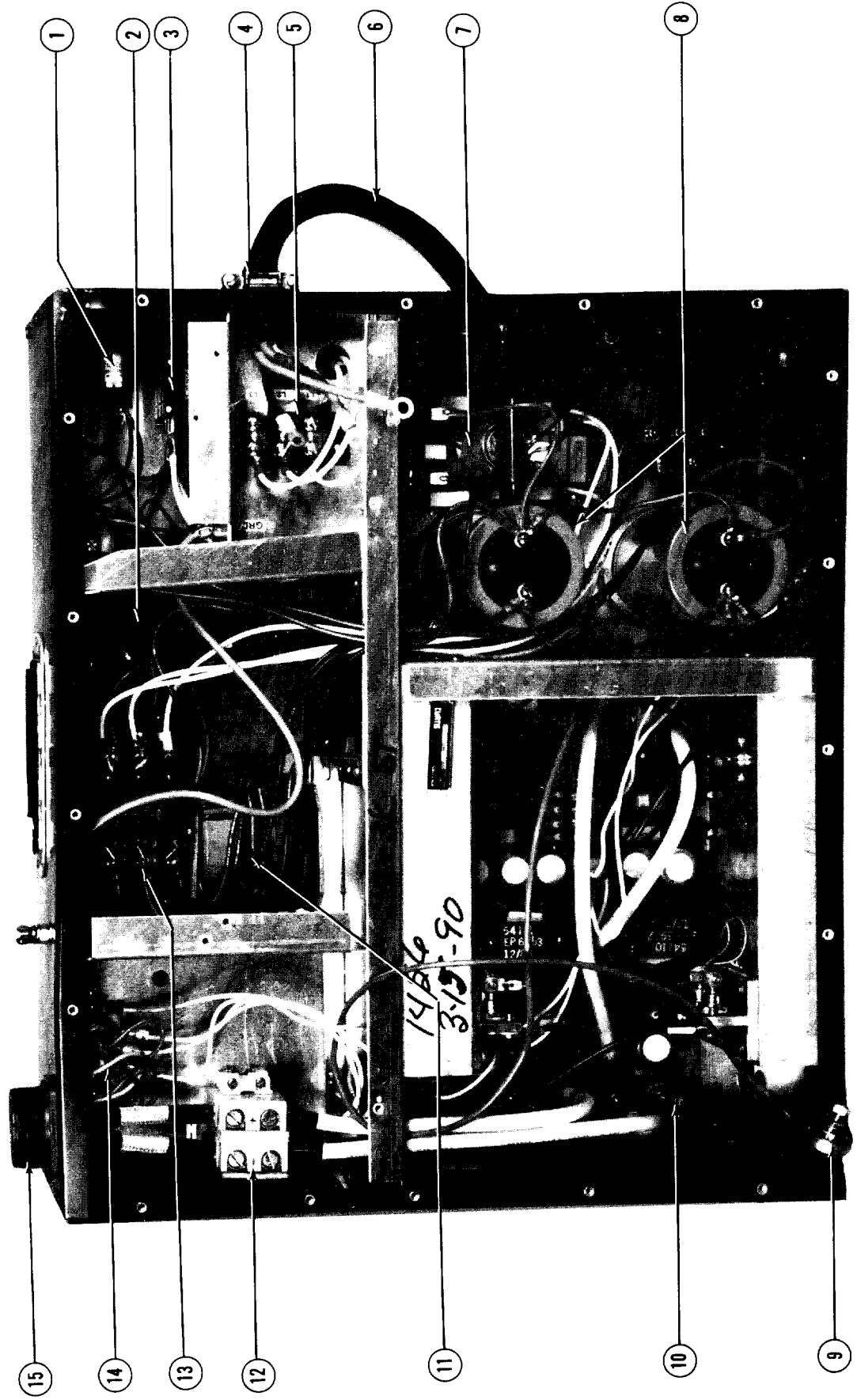

XENON POWER SUPPLY 62-80000

LAMPHOUSE - POWER SUPPLY INTERCONNECTION DIAGRAM

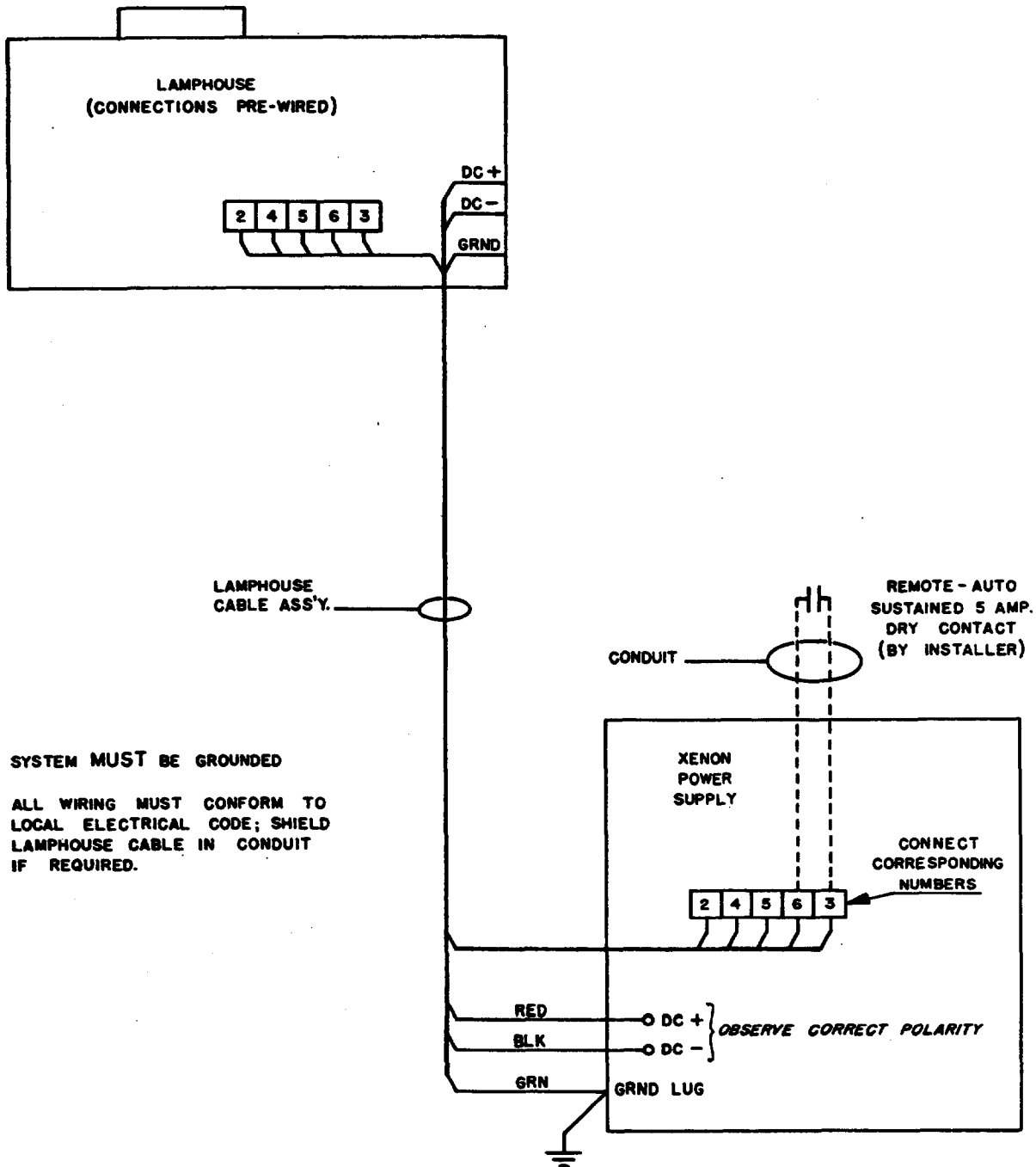

SYSTEM MUST BE GROUNDED

ALL WIRING MUST CONFORM TO LOCAL ELECTRICAL CODE; SHIELD LAMPHOUSE CABLE IN CONDUIT IF REQUIRED.

TROUBLESHOOTING

See Lamphouse Manual Before Troubleshooting Power Supply

Lamphouse Blower(s) Not Operating; Power Light "ON," Circuit Breaker "ON"

1. Lamphouse interlock switch open. See lamphouse manual.
2. Three ampere circuit breaker is tripped. Press to reset.
3. Improper AC input connection. Check AC voltage at contactor terminals; should read 190 - 240 V.AC across input terminals (L1, L2, L3 for three phase; L1 & L3 *only* for single phase).
4. Miswired output on terminals 2 & 4. Should read 100 - 120 V.AC; check wire numbers.
5. Defective circuit breaker. Check resistance across circuit breaker CB1 with supply OFF; should measure 0 Ohms. Replace as required.
6. Defective filter board. Check across each leg of the filter board input and output; voltage should measure 190 - 240 V.AC. Replace as required.
7. Defective stepdown transformer T6. Check input voltage at L1 & L3; should measure 190 - 240 V.AC. Check output voltage at 2 & 4; should measure 100 - 120 V.AC. Replace if defective.
8. Improper AC connections in lamphouse. Check AC voltage at 2 & 4 in lamphouse; voltage should measure 100 - 120 V.AC; check wire numbers.
- 8a. Gladiator spotlight lamphouse: wires 7 & 8 should measure 220 V.AC.
9. Lamphouse blower fuse blown (if applicable). See schematic in lamphouse manual.
10. Defective lamphouse blower. Check AC voltage at blower motor inputs; should measure 100 - 120 V.AC (Gladiator lamphouse blower: 220 V.AC) Replace if defective.

Lamphouse Blower(s) Operate, but Power Supply Contactor Does Not Close

1. No voltage on terminals 5 & 6. Possible open interlock switch in lamphouse or power supply; check air flow and interlock switches and interlock connections.
2. Incorrect setting of lamphouse MODE (AUTO - MAN.) switch. See lamphouse manual.
3. Faulty remote or automation contact (if using lamphouse in AUTO mode).
4. No voltage on terminals 5 & 6. Defective auto shut-down board. Replace if defective.
5. Defective contactor. Check for 100 V.DC or greater between P9 & P10 on power supply main board. If voltage is present and contactor does not close, replace contactor.
6. Defective contactor circuit. Check DC voltage present at terminals P9 & P10 on power supply main board. If less than 70 V.DC, contactor circuit is defective; *consult factory*.
7. Power supply overheated (open thermal switches). Check for correct blower operation and unobstructed air flow in power supply cabinet. Thermal switches will open if temperatures inside the power supply cabinet exceed 175° Fahrenheit (80° Celsius).

Xenon Bulb Fails to Ignite; Blowers Operating, Contactor Closed

1. Defective or expired xenon bulb. Replace as required.
 2. Incorrect igniter printed circuit board. Strong AC type igniters should be connected to high voltage igniter PC board (Part No. 40913, 65992B, or equivalent).
 3. Check DC no load output voltage. Should measure 150 - 180 V.DC; if lower, *consult factory*.
-

TROUBLESHOOTING (continued)

Xenon Bulb Fails to Ignite; Blowers Operating, Contactor Closed (cont'd.)

4. Faulty DC output connection. Check and correct as required. Tighten connections securely.
5. No DC voltage output. Blown fuse; *allow power supply twenty minutes (power OFF) to discharge capacitors before removing fuse*. Good fuse should measure 0 Ohms; replace as required (Strong Part No. 61-21001). If fuse blows repeatedly, *consult factory*.
6. Defective contactor. Check continuity of contacts between "L" terminals to "T" terminals. Should measure 0 Ohms on all (4) poles with contactor closed. Replace if defective.
7. Defective igniter. Allow unit to cool and attempt re-ignition. Check DC voltage at output; should measure 150 V.DC or higher. If voltage is correct, check DC connections in lamphouse and power supply; tighten securely. Attempt re-ignition; if no ping is audible in the lamphouse, replace igniter. If ping is audible, but no flash is apparent, check for lamphouse DC lead shorting to ground. If ping is heard and arc is visible between bulb electrodes, and bulb fails to ignite, replace bulb.

Xenon Bulb Goes Out During Operation (Intermittent Operation)

1. Defective or expired xenon bulb. Replace as required.
2. Fault in lamphouse interlock circuit (loose access door, inadequate exhaust draft). See lamphouse manual.
3. Power supply overheated. Check for blower operation and unobstructed air flow in power supply enclosure. Thermal switches will open if heat sink temperatures exceed 175° Fahrenheit (80° Celsius).
4. AC phase loss. Meter AC input.
5. Brown-out (voltage drop) in AC supply. Measure AC source.

No Output Current Adjustment

1. Defective mother board. *Consult factory*.

Xenon Power Supplies, Lamphouse Igniters, and other components shipped to the factory for credit, repair or repair/exchange *must* be returned through an authorized Strong International Equipment Dealer. Contact your Strong International Dealer for a **Return Authorization** and instructions prior to shipping any goods to Strong.

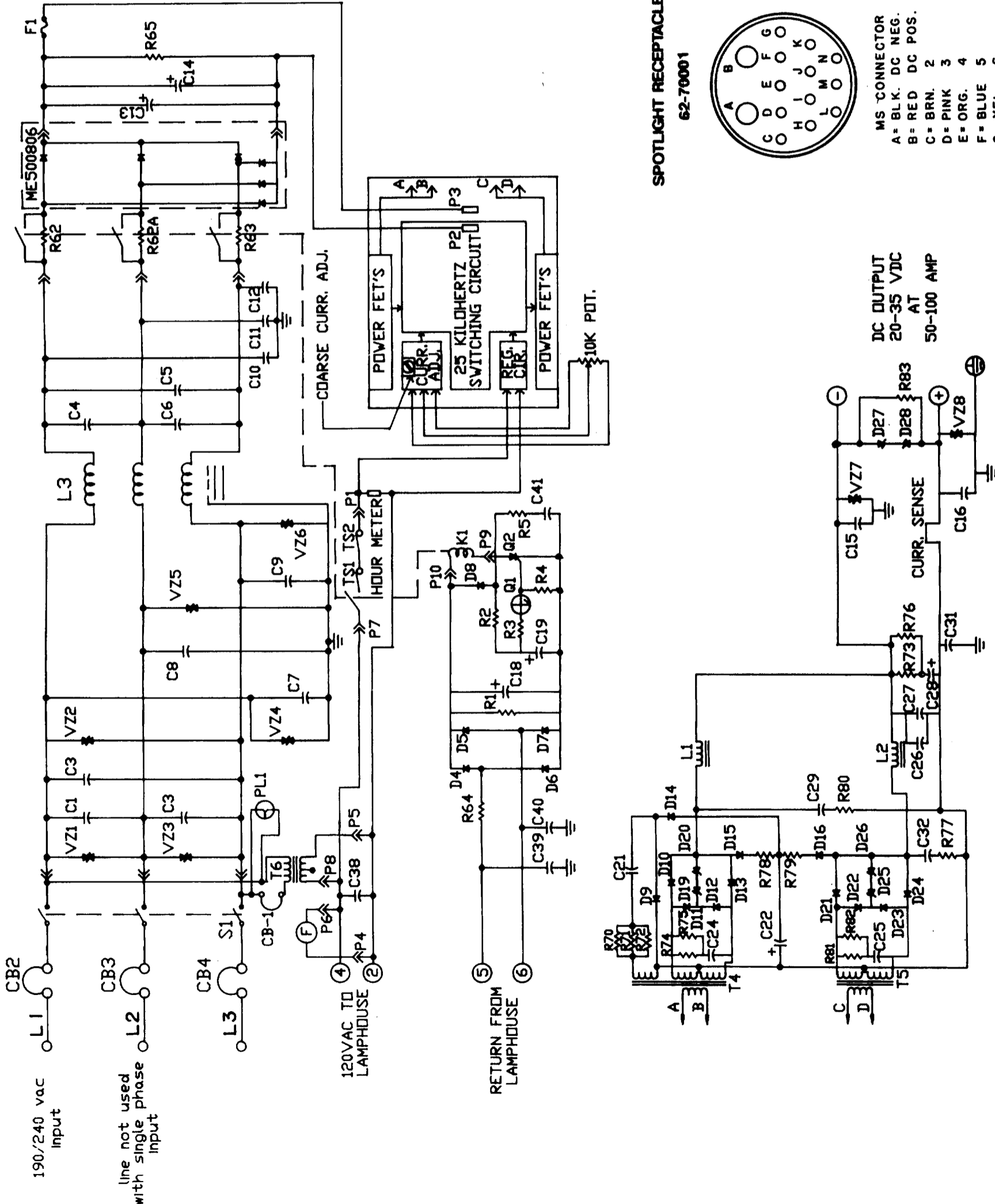

SPOTLIGHT RECEPTACLE
62-70001

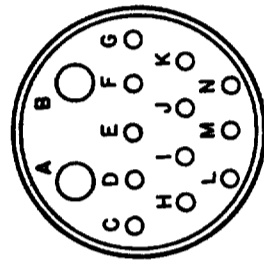

- MS CONNECTOR
 A = BLK. DC NEG.
 B = RED DC POS.
 C = BRN. 2
 D = PINK 3
 E = ORG. 4
 F = BLUE 5
 G = YEL. 6

DC OUTPUT
 20-35 VDC
 AT
 50-100 AMP

PART NUMBER	DESCRIPTION
VZ1,2,3,4,5,6	390V MOV
VZ7,8	200V MOV
S1	30A 3 PHASE BREAKER
F1	16A 600V FUSE
CB-1	3A BREAKER
CB2,3,4	30A LINE BREAKERS
PL-1	RED POWER LIGHT
TS1,2	185° THERMAL SENSOR
T4, T5	OUTPUT TRANSFORMERS
K1	4 POLE 30A CONTACTOR
L1, L2	TOROIDAL OUTPUT CHOKE
L3	RFI INPUT CHOKE
F	110VAC FANS
T6	220V/110V STEPDOWN
P1,2,3,4,5,6,7,8,9,10	SPADE TERMINAL CONN.
C1,2,3,4,5,6	.47MF 250V
C7,8,9,10,11,12	.022MF 250V
C38,39,40	.022MF 300V
C13,14	3300MF 350V
C18	22MF 250V
C19	47MF 25V
C41	.1MF 200V
C24,25,29,32	.01MF 400V
C22,28	220MF 250V
C26,27	.47MF 250V
C15,16,21,31	.22MF 250V
D28	1N5378
Q1	2N4988
Q2	2N5064
D4,5,6,7,8	1N4004
D10,13,21,24	UES806R
D19,20,25,26,27	1N5386
D9,11,12,14,15,16,22,23	BYV26B
R65	5 OHM 50 WATT
R6	12K 25 WATT
R64	220 OHM 3 WATT
R1,R83	82KOHM
R2	220KOHM
R4	470 OHM
R5	1KOHM
R70,71,72	1KOHM 3 WATT
R74,75,81,82	22 OHM 3 WATT
R73,76,77,78,79,80	10 OHM 3 WATT

BALLANTYNE <i>of Ontario</i>		DESIGN BY	REVISION BY
		DATE	NO.
MEAS. NONE APP. 4/19/89 TITLE		DRAWN BY REVISED NO.	
XENON SWITCHER POWER SUPPLY			
EQUIPMENT TYPE 62-80000			

BLOCK DIAGRAM

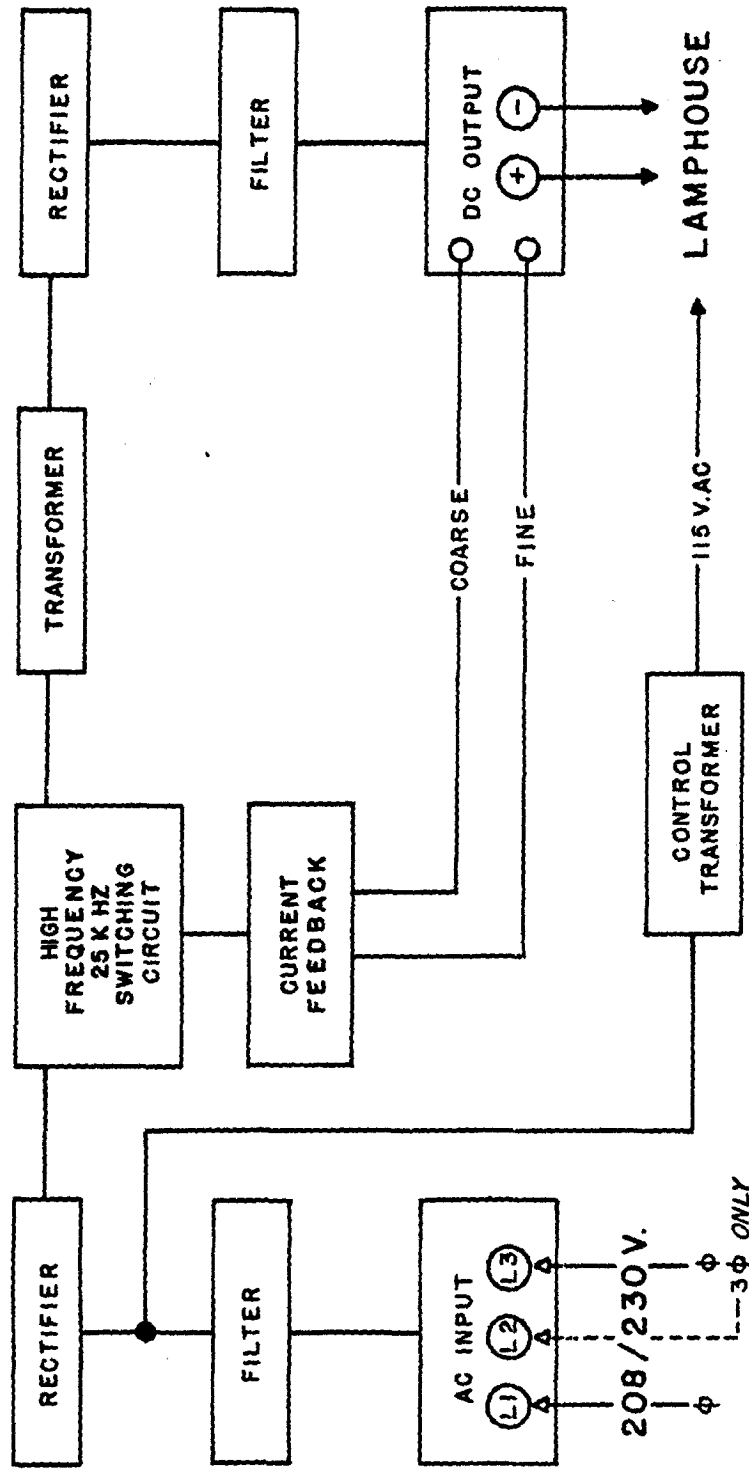

SEE "INSTALLATION" INSTRUCTIONS