

Film-Tech

The information contained in this Adobe Acrobat pdf file is provided at your own risk and good judgment.

These manuals are designed to facilitate the exchange of information related to cinema projection and film handling, with no warranties nor obligations from the authors, for qualified field service engineers.

If you are not a qualified technician, please make no adjustments to anything you may read about in these Adobe manual downloads.

www.film-tech.com

INSTRUCTION MANUAL

XENON POWER SUPPLY

Type 62-81001
Type 62-81002
120 V. AC Input



STRONG INTERNATIONAL

4350 McKinley St.
Omaha, Nebraska 68102
402/453-4444 Telex 484481

PREFACE

The Strong International switching power supply Type 62-81000 is designed to operate a xenon bulb in all theatrical lighting applications for Strong lamphouses. This unit will operate all xenon bulbs rated from 500 to 2000 watts throughout their full operating ranges* (17-27 V.DC, 20-74 A.DC). The power requirement for this unit is 120 V.AC, 24 amperes nominal, single phase, 50/60 Hz.

Incoming line power is transformed from 120 volts AC to a low voltage, high current DC output. The incoming AC line is filtered to eliminate noise and is then converted to DC. This DC voltage is switched on and off by a solid state switching circuit, and converted to a 25 kHz. square wave. The square wave is fed into output transformers to provide low voltage and high current. Rectifiers convert the 25 kHz. signal to DC, and the output is filtered to eliminate noise and ripple. Output to the xenon bulb is controlled through use of (2) potentiometers (coarse and fine).

An isolation transformer filters the incoming line. A control circuit powers the lamphouse igniter and blower(s). A separate circuit breaker protects the control circuit in the event of a lamphouse component malfunction.

Refer all servicing of this power supply to an authorized Strong International Dealer. There are no user serviceable components in this unit.

* 500 W.	20 - 33 A.
700 W.	25 - 40 A.
1000 W.	40 - 58 A.
1600 W.	50 - 70 A.
2000 W.	50 - 74 A.

INSTALLATION - OPERATION

CAUTION: High voltages exist inside the power supply enclosure. Remove **only** the (2) small access panels in the power supply cabinet for installation procedures. The input panel is located near the circuit breakers; the output on the opposite corner.

Connect the lamphouse leads to the output side of the power supply prior to connecting to AC power. Lamphouse to power supply connections are illustrated in the lamphouse instruction manual. Make certain the lamphouse is grounded.

Power leads run to the unit must be of the correct size and type to conform to local codes. Shield in conduit as required. The power supply will not energize until the circuit breakers on the side of the cabinet are placed in the ON position.

Connect 120 V.AC single phase input to L1 (Neutral, white wire) and L3 (Phase "hot", black wire). Attach the ground lug to an adequate ground. All wiring must conform to local codes.

If the factory supplied three-wire AC power cord is used (standard with spotlight models; optional with motion picture units), the cord **must** connect to an installer supplied UL[®] listed NEMA type 9550 NP plug (and corresponding receptacle) wired in conformance to local codes.

See the warranty information packed with the xenon bulb for correct operating current. **Do not exceed, at any time, the maximum current level specified by the bulb manufacturer.**

Adjust the current output to the bulb through use of the (2) adjustment potentiometers. The FINE adjust potentiometer is located inside the access opening used for lamphouse connection. The COARSE potentiometer is located inside the cabinet on the mother board. Check the lamphouse ammeter on the first bulb ignition, and adjust the FINE potentiometer to the desired bulb current. Rotate the potentiometer clockwise to increase current, or counterclockwise to reduce current. **If the bulb current is too low at the highest setting of the FINE potentiometer, rotate the COARSE potentiometer slightly clockwise. If the bulb current is too high at the lowest setting of the FINE potentiometer, rotate the COARSE potentiometer slightly counterclockwise.**

The lamphouse control circuit is factory prewired. Terminals 2 & 4 supply 120 V.AC to the lamphouse blower(s). After completing the lamphouse interlock circuit, the 120 V.AC return to the power supply on wires 5 & 6 to close the

contactor on closure of the LAMP ON switch. The same (5 & 6) circuit energizes the lamphouse igniter. Terminals 3 & 6 are dry contact switching terminals for remote or automated control. See lamphouse manual Installation Diagram. Do not apply voltage to terminals 3 & 6.

MAINTENANCE

The power supply requires very little service to insure correct operation. Periodically check all electrical connections for tightness and condition; discolored terminals may indicate oxidation which will increase resistance and heat.

Clean the ventilation inlet and outlet grilles on a regular basis to insure good air flow. Thermal switches mounted to the power supply will interrupt operation of the power supply in the event of overheating.

The blower motors are permanently lubricated and require no oil.

LAMPHOUSE - POWER SUPPLY INTERCONNECTION DIAGRAM

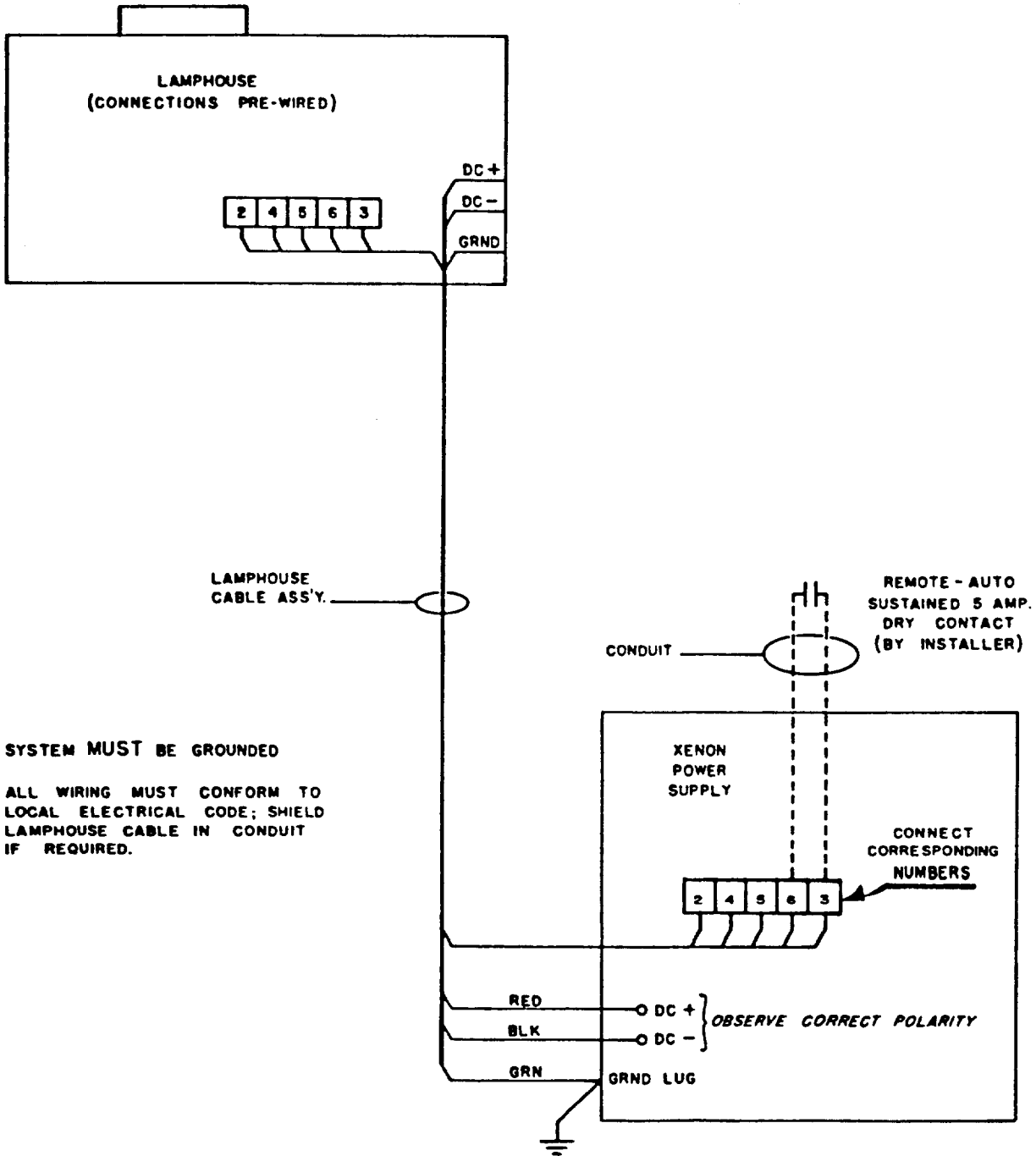

TROUBLESHOOTING

See Lamphouse Manual Before Troubleshooting Power Supply

No Lamphouse Blowers; Power Light ON, Supply ON, Breaker ON

1. Three ampere circuit breaker is tripped. Press to reset.
2. Improper AC connection. Check AC voltage at contactor terminals; should read 100 - 120 V.AC across L1 & L3 (single phase).
3. Miswired output on terminals 2 & 4. Should read 100 - 120 V.AC; check wire numbers.
4. Defective circuit breaker. Check resistance across circuit breaker CB1 with supply OFF; should measure (0) Ohms. Replace if defective.
5. Defective filter board. Check across each leg of the filter board input and output; should measure 100 - 120 V.AC. Replace as required.

Lamphouse Blowers Operate, but Power Supply Contactor Does Not Close

1. LAMP "ON" or MODE switch not set correctly. See Lamphouse Manual.
2. No voltage on terminals 5 & 6. Possible open interlock switch(s); see Lamphouse Manual.
3. Defective contactor circuit. If 100 - 120 V.AC not measured between P8 & P10, check for loose connection. If voltage is present, and contactor does not close, replace contactor.
4. Power supply overheated (open thermal switches). Check for correct blower operation and unobstructed air flow. Thermal switches will open if temperatures inside the power supply cabinet exceed 190° F. (88° C.).

Bulb Fails to Ignite; Blowers Operating, Contactor Closed

1. Check DC No Load output; should measure 120 - 140 V.DC. If lower, **consult factory.**
2. Faulty DC output connection. Check and tighten as required.
3. Blown fuse. **Allow power supply (15) minutes to discharge (power OFF) before removing the fuse.** Fuse should measure (0) Ohms. Replace as required.
 - 3a. Fuse blowing repeatedly. Loose DC connection; check and retighten. Burned cables on mother board; inspect and replace as required.
4. Defective contactor. Check continuity from "L" poles to "T" poles; should read (0) Ohms with contactor closed. Replace if defective.

No Current Adjustment

Defective mother board. **Consult factory.**

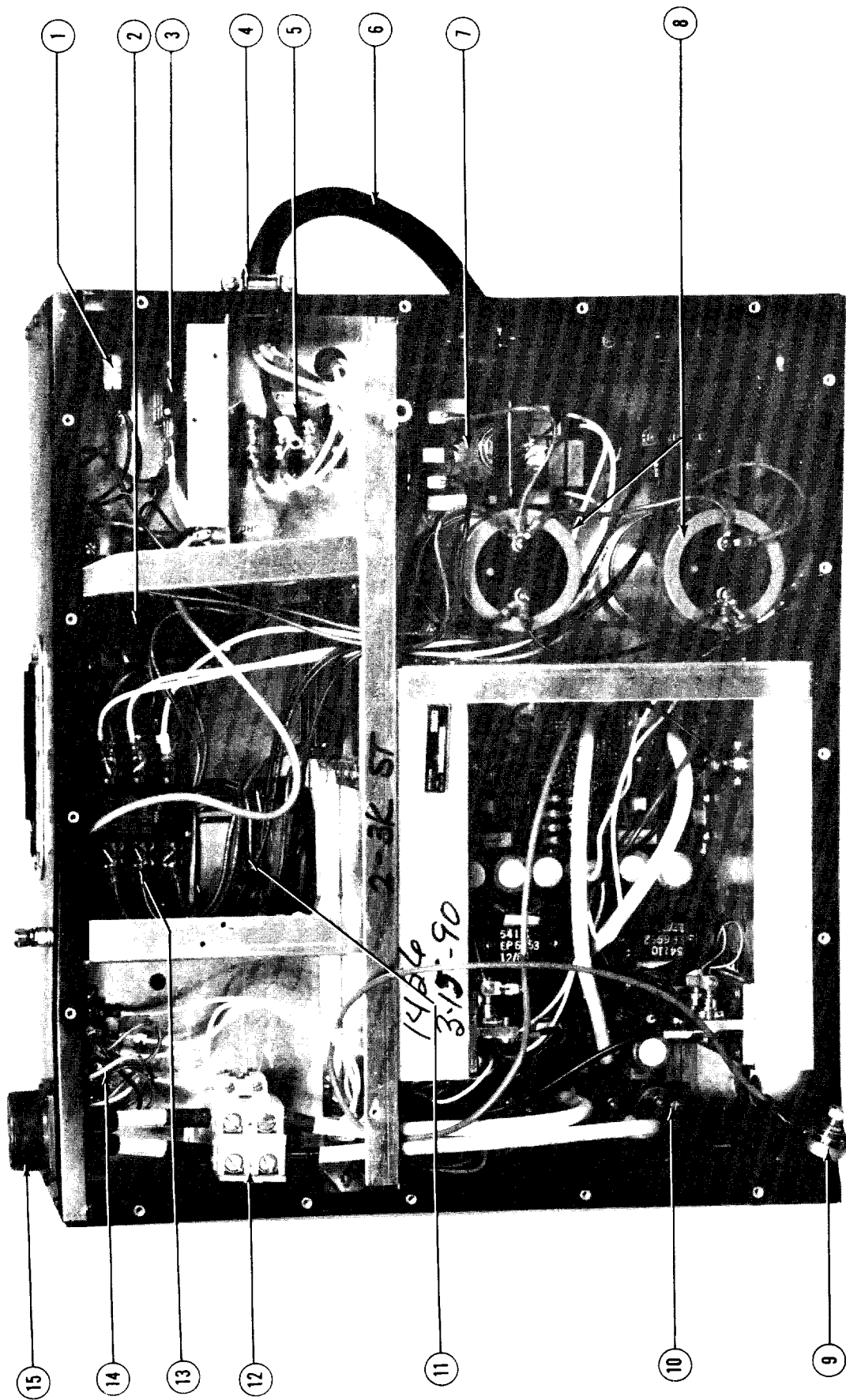

1

2

3

4

5

6

7

8

15

14

13

12

11

10

9

PLUG - BY INSTALLER - Conform to Local Codes

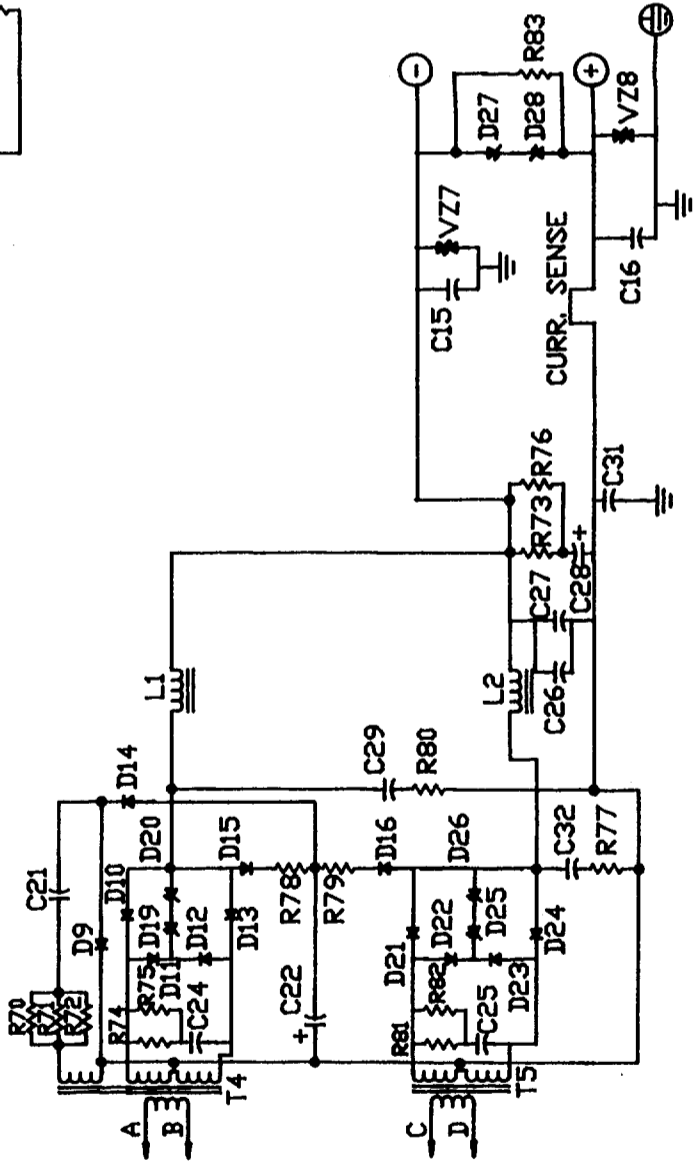
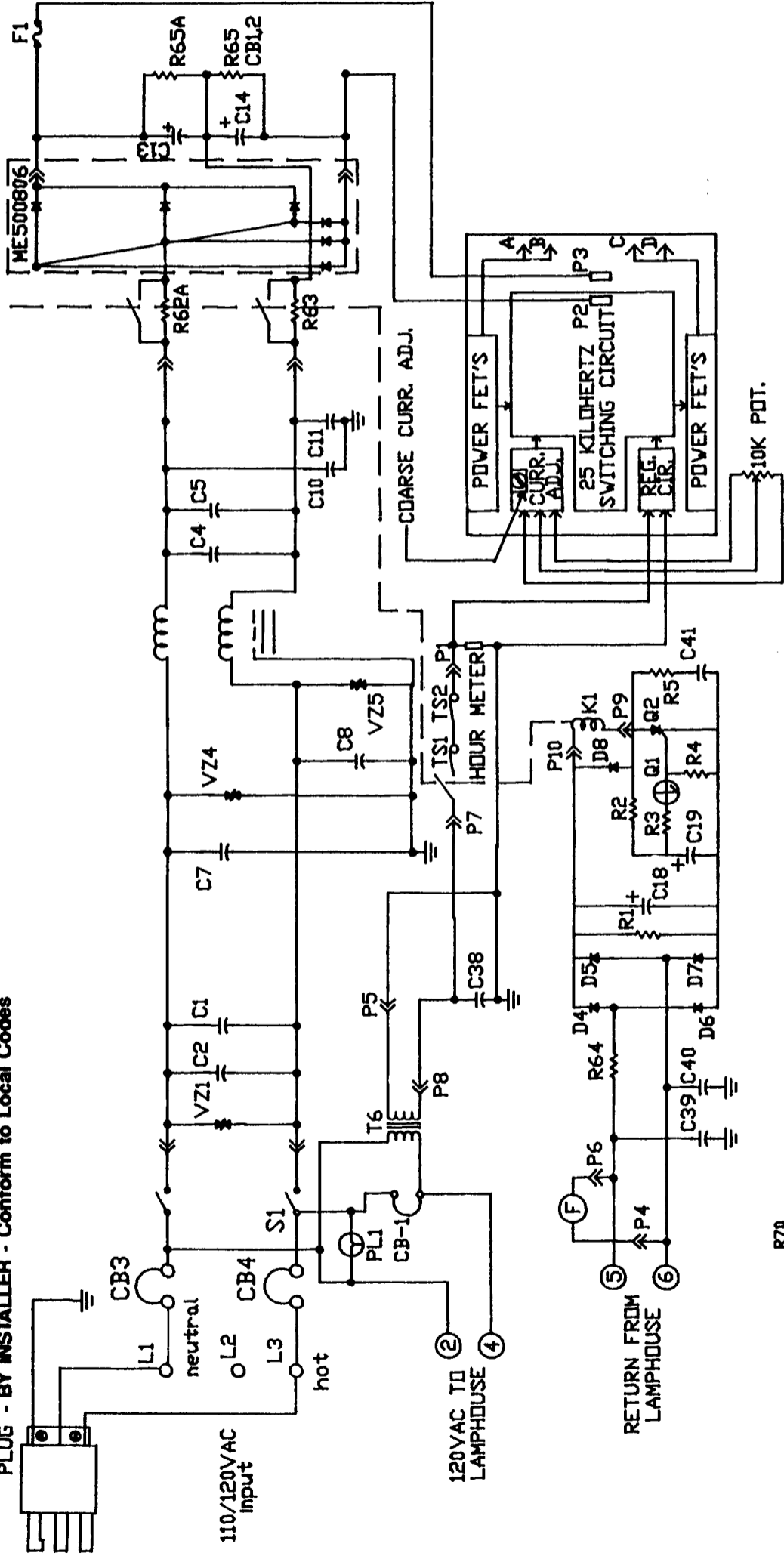

DC OUTPUT
20-35 VDC
AT
50-100 AMP

PART NUMBER	DESCRIPTION
VZ1,4,5	390V MOV
VZ7,8	200V MOV
S1	30A 1PHASE BREAKER
F1	16A 600V FUSE
CB-1	3A BREAKER
CB3,4	30A LINE BREAKERS
PL-1	RED POWER LIGHT
TS1,2	185° THERMAL SENSOR
T4,T5	OUTPUT TRANSFORMERS
K1	3 POLE 30A CONTACTOR
L1,L2	TOROIDAL OUTPUT CHOKE
L3	RFI INPUT CHOKE
F	110VAC FANS
T6	ISOLATION TRANSFORMER
P1,2,3,4,5,6,7,8,9,10	SPADE TERMINAL CONN.
C1,2,4,5	.47MF 250V
C7,8,10,11	.022MF 250V
C38,39,40	.022MF 300V
C13,14	5400MF 200V
C18	22MF 250V
C19	47MF 25V
C41	.1MF 200V
C24,25,29,32	.01MF 400V
C22,28	220MF 250V
C26,27	.47MF 250V
C15,16,21,31	.22MF 250V
D28	1N5378
Q1	2N4988
Q2	2N5064
D4,5,6,7,8	1N4004
D10,13,21,24	UES806R
D19,20,25,26,27	1N5386
D9,11,12,14,15,16,22,23	BYV26B
R62A,63	5 OHM 50 WATT
R65,R65A	5KOHM 3 WATT
R64	220 OHM 3 WATT
R1R83	82KOHM
R2	220KOHM
R4	470 OHM
R5	1KOHM
R70,71,72	1KOHM 3 WATT
R74,75,81,82	22 OHM 3 WATT
R73,76,77,78,79,80	10 OHM 3 WATT
R3	220 OHM

BALLANTYNE <i>of</i> <small>Cromwell</small>	
DESIGNED BY	APPROVED BY
DATE	DATE
TITLE	NO.
XENON SWITCHER POWER SUPPLY	

SWITCHING TYPE XENON POWER SUPPLY
Series 62-81000

<u>Item</u>	<u>Description</u>
1	Power Indicator Light, Red (PL-1)
2	Isolation Transformer (T6)
3	Circuit Breaker, 1 Phase (CB2,3)
4	Strain Relief, Power Cord *
5	AC Input Terminal Block
6	AC Power Cord *
7	Filter Board Assembly
8	Filter Capacitors (C13,14)
9	Fine Current Adjustment Potentiometer (Normally Mounted Adjacent to Item 14)
10	Mother Board
11	Torroidal Output Choke (L1,2)
12	DC Output Terminal Block
13	Power Contactor (K1)
14	Lamphouse AC Control Circuit Terminal Block
15	MS Connector Assembly *

* Standard on Spotlight Models; Otherwise Optional