

Film-Tech

The information contained in this Adobe Acrobat pdf file is provided at your own risk and good judgment.

These manuals are designed to facilitate the exchange of information related to cinema projection and film handling, with no warranties nor obligations from the authors, for qualified field service engineers.

If you are not a qualified technician, please make no adjustments to anything you may read about in these Adobe manual downloads

www.film-tech.com

CHRISTIE

I N C O R P O R A T E D

Operating Instructions For



TD-685

CHRISTIE INC.
10550 Camden Dr.
Cypress, Ca 90630
714-236-8610 Fax 714-229-3185

General Description

The CHRISTIE 3Q is a console mounted, cue driven automation designed specifically for the CHRISTIE P35GPS Projector/SLC console combination. This cost efficient design provides control of most booth and auditorium functions including: the projector motor, Xenon lamp, changeover douser, house light dimmer (*up/mid/down*), audio switching (*Stereo/SR/Digital/Non-sync*), stage curtains, slide projector, remote status indication (*run/stop/fault/ready*), built-in two projector interlock, full remote capability, lens turret/masking and Xenon Auto-Focus control (*for properly equipped projectors and consoles*). The automation provides manual control of all functions and cues as well as two user assignable option switches pre-wired to the main terminal board.

The automation utilizes a reliable cue detector instead of a cam timer, to initiate the various automated functions. A cue expander may be utilized to provide up to four additional custom functions (*i.e. special dimmer functions, mid-show stop, additional sound formats, etc.*). The compact printed circuit board design provides reliable, trouble-free operation with the familiarity and simplicity of electro-mechanical relays.

SUMMARY OF FEATURES

- ◆ Designed specifically for P35GPS/SLC combination
- ◆ Separate trailer and feature pre-selects for picture and audio formats
- ◆ Reliable relay and PCB based design
- ◆ Built-in two projector interlock
- ◆ Full manual controls for all functions including cues
- ◆ All low voltage controls on PCB
- ◆ LED illuminated run, stop, and cue buttons for long service life
- ◆ Panel mounted alarm buzzer
- ◆ Two pre-wired, user assignable option switches
- ◆ Full remote control and status capabilities

NORMAL SHOW SEQUENCE

Start Button

Motor On
Lamp On
Douser Close
Slide Projector Off
Lens/Masking/AutoFocus to Start Format (*selectable*)

◆ **Start Cue ----- at beginning of trailers**

Dimmer Mid or Down
Curtain Open
Douser Open
Start Audio to Stereo or SR (*selectable*)
Status Indicator to Run

◆ **Feature Cue ----- at beginning of feature**

Dimmer Down
Feature Audio to Stereo, SR or Digital (*selectable*)
Lens/Masking/AutoFocus to Feature Format (*selectable*)

◆ **Show End Cue ----- at end of feature credits**

Curtain Close
Douser Close
Dimmer Up
Audio to Non-Sync
Lens/Masking/Auto Focus to Start Format (*selectable*)

◆ **Film Run Out**

Motor Off
Lamp Off
Slide Projector On
Status Indicator to Stop

◆ **Fault (Film Break)**

Motor Off
Lamp Off
Dimmer Up
Slide Projector On
Status Indicator to Fault
Alarm Sounds

◆ **Cancel Alarm**

Shuts off Alarm
Douser Close
Audio to Non-Sync

CUE PLACEMENT

The **CHRISTIE 3Q** automation utilizes three different cues for normal show operation.

- .. **Show Start** - (inboard cue)
 - placed two feet prior to the start of the trailers.

- .. **Feature** - (cross cue)
 - placed two feet prior to the start of the feature or policy trailer.

- .. **Show End** - (outboard cue)
 - placed two feet prior to the end of the credits.

Note

The automation may be used with any cue sensor which provides at least three cues with consistent duration contact closure when a cue is detected.

Although only three cues are required for normal show operation, an expander board may be added to further customize show operations.

COMPONENT FUNCTION

SWITCH	FUNCTION
Start (PB - 1)	Latches Start Relay, engaging motor and lamp. Turret/masking to start format, closes douser, audio to non-sync. Slide projector OFF. Will not start if fail-safes are down. L.E.D. illuminated, green when active.
Stop (PB - 2)	Disengages Start Relay, motor and lamp OFF. Slide projector ON. L.E.D. illuminated, red when active or fail-safes are down.
Motor (S1)	Manual motor control.
Lamp (S2)	Manual lamp control.
Douser (S3)	Manual opening and closing of changeover douser.
Dimmer (S4)	Manual raising or lowering of house lights.
Format (S5)	Manual control of lens turret/aperture/masking/Auto-Focus.
Start Audio (S6)	Selects trailer audio format to Stereo or SR.
Start Format (S7)	Selects trailer picture format to Flat or Scope.
Feature Audio (S8)	Selects feature audio format to Stereo, SR or Digital.

SWITCH	FUNCTION
Feature Format (S9)	Selects feature picture format to Flat or Scope.
Start Cue (PB - 3)	Manual Show Start Cue. Active only when Start Relay is latched. Brings lights to MID, audio to Mono/Stereo, douser open, curtain open.
Feature Cue (PB - 4)	Manual Feature Cue. Active only when Start Relay is latched. Brings lights to LOW, audio to Stereo/SR, feature picture format to Flat or Scope.
Show End Cue (PB - 5)	Manual Show End Cue And Alarm Cancel. Brings lights UP, audio to non-sync, douser close, curtain close, start picture format to Flat or Scope.
Option 1 (S10)	ON/OFF Switch. May be used for interlock activation. Pre-wired to TB5 38-41. <i>(see wiring diagram)</i> .
Option 2 (S11)	Momentary Switch. May be used for manual curtain control. Pre-wired to TB5 42-44. <i>(see wiring diagram)</i> .
Buzzer (LS1)	Sounds alarm if a film break occurs.
Fuse (F1)	Automation main fuse, 2 Amp., 3AGC.

COMPONENT	FUNCTION
-----------	----------

P.C.B. Assembly		All low voltage control circuitry.
Start Relay	(K1)	Latches through Stop Relay. Holds Power Relay latched engaging motor and lamp.
Stop Relay	(K2)	Disengages Start Relay. Relay is latched when fail-safes are down.
Alarm Relay	(K3)	Sounds alarm if Stop Relay is latched due to fail-safe. Alarm sounds if show is between the Show Start and Show End Cues.
Show End Relay	(K4)	Actuates Show End Cue functions. Disengages Alarm Relay.
Feature Relay	(K5)	Actuates all Feature Cue functions.
Show Start Relay	(K6)	Actuates all Show Start Cue functions. Latches Alarm Relay.
Power Relay	(K7)	Activated by Start Relay engages motor and lamp. 3PDT, 12VAC coil, with 10A rated contacts
Open Relay	(K8)	Opens douser and stage curtains. 3PDT, 12VAC coil, with 10A rated contacts.
Close Relay	(K9)	Closes douser and stage curtains. 3PDT, 12VAC coil, with 10A rated contacts.
Transformer	(T1)	12VAC , 2 Amp transformer. Provides 12V power for automation.

All relays are 4PDT, 12VAC coil with contacts rated at 5A @125V except where designated.

INTERLOCK - TWO PROJECTOR

Note

Make sure both Automations are on the same phase. TB5-25 should read 0 VAC between the two Automations. (*see wiring diagram*).

- ◆ Connect Remote Start (46) to Option 1A Common (38) in each automation.
- ◆ Connect Fail-safe Interlock (45) to Option 1B Common (40) in each automation.
- ◆ Connect Option 1A N.O. (39) and Option 1B N.O. (41) from projector 1 to their corresponding terminals on projector 2.

Check

- Switching on the Option 1 switches in both automations will activate interlock.
- Tie-up both sets of fail-safes to ready position.
- Press start on either automation. Both projectors' motors and lamps will start.
- As the cues pass through each automation, functions will be performed independently as usual.
- Once the Show Start Cue has gone through both automations, fail-safe protection for the interlock will be active. Dropping of the fail-safes on either projector will stop both projectors, raise the house lights, and sound the alarms. Once the Show End Cue has gone through one of the automations, interlock fail-safe will be discontinued and the projectors will shut off independently as the film runs out.

TERMINAL ASSIGNMENT

TB-1 Automation PCB (Reference Only)

1.	Dimmer Switching Common	(W78)
2.	Dimmer Up	(W79)
3.	Dimmer Mid	(W13)
4.	Dimmer Down	(W80)
5.	Audio Switching Common	(W15)
6.	Start Audio Format	(W62)
7.	Feature Audio Format	(W63)
8.	Non-Sync	(W19)
9.	Show Start Cue	(W64)
10.	Feature Cue	(W81)
11.	Show End Cue	(W82)
12.	Cue Common	(W65)
13.	Fail-Safe	(W83)
14.	Remote Start	(W88)
15.	Ground (<i>Automation Switching Common</i>)	(W84)
16.	12VAC	(W85)
17.	Run Indicator	(W26)
18.	Stop Indicator	(W27)
19.	Fault Indicator/Alarm	(W86)
20.	Format Switching Common	(W87)
21.	Start Format	(W89)
22.	Feature Format	(W90)
23.	Interlock Fail-Safe (<i>Input/Output</i>)	(W45)
24.	Buzzer output	(W91)

TB-2 Automation PCB (Reference Only)

1.	12 VAC	(W117/W122)
2.	Ground	(W118/W123)
3.	Power Relay	(W119)
4.	Open Relay	(W120)
5.	Close Relay	(W121)
6.	Alarm Active (12VAC when active)	

TB-3	Automation Chassis (Reference Only)
-------------	--

1.	Line 115VAC	(W61)
2.	Neutral	(W2)
3.	Ground	(W3)
4.	Motor	(W71)
5.	Motor	(W72)
6.	Lamp	(W73)
7.	Lamp	(W74)
8.	Douser Common	(W75)
9.	Douser Open	(W76)
10.	Douser Close	(W77)
11.	Curtain Common	(W35)
12.	Curtain Open	(W36)
13.	Curtain Close	(W37)
14.	Dry Circuit Common	(W29)
15.	Dry Circuit N.C.	(W30)
16.	Dry Circuit N.O.	(W31)

TB-5	Main Console Terminal Board (Field Terminations)
-------------	---

1.	Line 115VAC Feed to Automation	(W1)
2.	Neutral to Automation	(W2)
3.	Ground	(W3)
4.	Motor	(W4/W71)
5.	Motor	(W5/W72)
6.	Xenon	(W6/W73)
7.	Xenon	(W7/W74)
8.	Douser Common	(W8/W75)
9.	Douser Open	(W9/W76)
10.	Douser Close	(W10/W77)
11.	Dimmer Switching Common	(W11/W78)
12.	Dimmer Up	(W12/W79)
13.	Dimmer Mid	(W13)
14.	Dimmer Down	(W14/W80)
15.	Audio Switching Common	(W15)
16.	Stereo	(W16)
17.	SR	(W17)
18.	Digital	(W18)
19.	Non-Sync	(W19)
20.	Show Start Cue	[N.O. CIRCUIT](W20/W64)
21.	Feature Cue	[N.O. CIRCUIT](W21/W81)
22.	Show End Cue	[N.O. CIRCUIT](W22/W82)

23.	Fail-Safe (<i>Fire Alarm Shutdown</i>)	(W23/W83)
24.	Ground (<i>Switching Common</i>)	(W24/W84)
25.	12VAC	(W25/W85)
26.	Run Indicator	(W26)
27.	Stop Indicator	(W27)
28.	Fault Indicator/Alarm	(W28/W86)
29.	Dry Circuit Common	(W29)
30.	Dry Circuit N.C. [15A CONTACT]	(W30)
31.	Dry Circuit N.O.	(W31)
32.	Lens Common	(W32/W87)
33.	Lens Flat	(W33)
34.	Lens Scope	(W34)
35.	Curtain Common	(W35)
36.	Curtain Open	(W36)
37.	Curtain Close	(W37)
38.	Option 1A Common	(W38)
39.	Option 1A N.O.	(W39)
40.	Option 1B Common	(W40)
41.	Option 1B N.O.	(W41)
42.	Option 2 Common	(W42)
43.	Option 2 A	(W43)
44.	Option 2 B	(W44)
45.	Fail-Safe Buss (<i>Input/Output</i>)	(W45)
46.	Start Buss [N.O. CIRCUIT]	(W46/W88)
47.	Masking Common	(W47)
48.	Masking Flat	(W48)
49.	Masking Scope	(W49)

Note

Unless otherwise noted, all circuits are dry contact closure and are rated for low voltage controls only.

PARTS LIST

COMPONENT	PART NUMBER
------------------	--------------------

.. **Push Buttons**

Start (Green)	578000-079
Stop (Red)	578000-078
Cues (White)	578000-077

.. **Switches**

S1, S2, S10 (DPST)	578722-024
S3, S4, S5, S11 (SPDT, Mom.)	578712-018
S6, S7, S8 (SPDT)	578722-017
S9 (SPDT, Center off)	578712-003

.. **Relays**

K1-K6 (4PDT, Small)	599000-122
K7-K9 (3PDT, Large)	571312-001

.. **Other**

Buzzer	546900-035
Transformer	587700-077
Fuse	546102-011

Appendix A: Wiring Diagrams

Appendix A contains wiring diagrams associated with options available with the 3Q automation.

- Cue Detector Wiring, for 598931-690 Cue Detector
- Option One Wiring, Two Projector Interlock
- Option Two Wiring, Manual Curtain Control
- Option Two Wiring, Manual Masking Control
- 3Q Status Panel Wiring
- 3Q Status Wiring Riser Diagram
- Phase Check, Two Projector Interlock
- 3Q Wiring w/o P35GPS Projector
- 3Q Automation Schematic

Cue Detector Wiring and Cue Placement

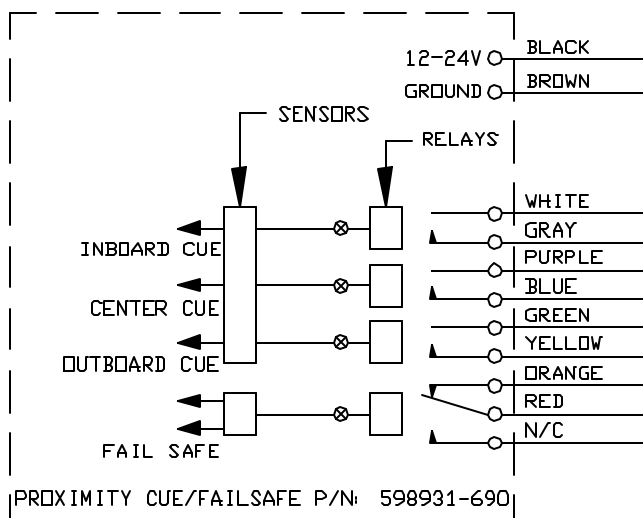
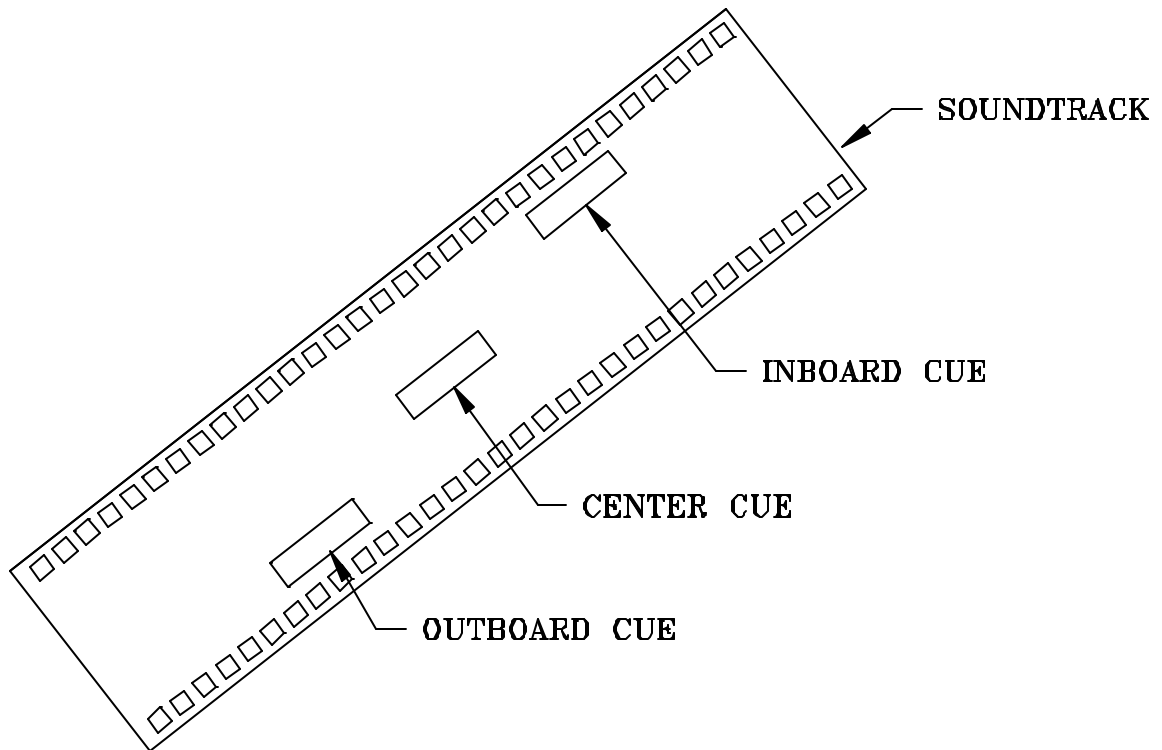

Option 1 Wiring

Two Projector Interlock

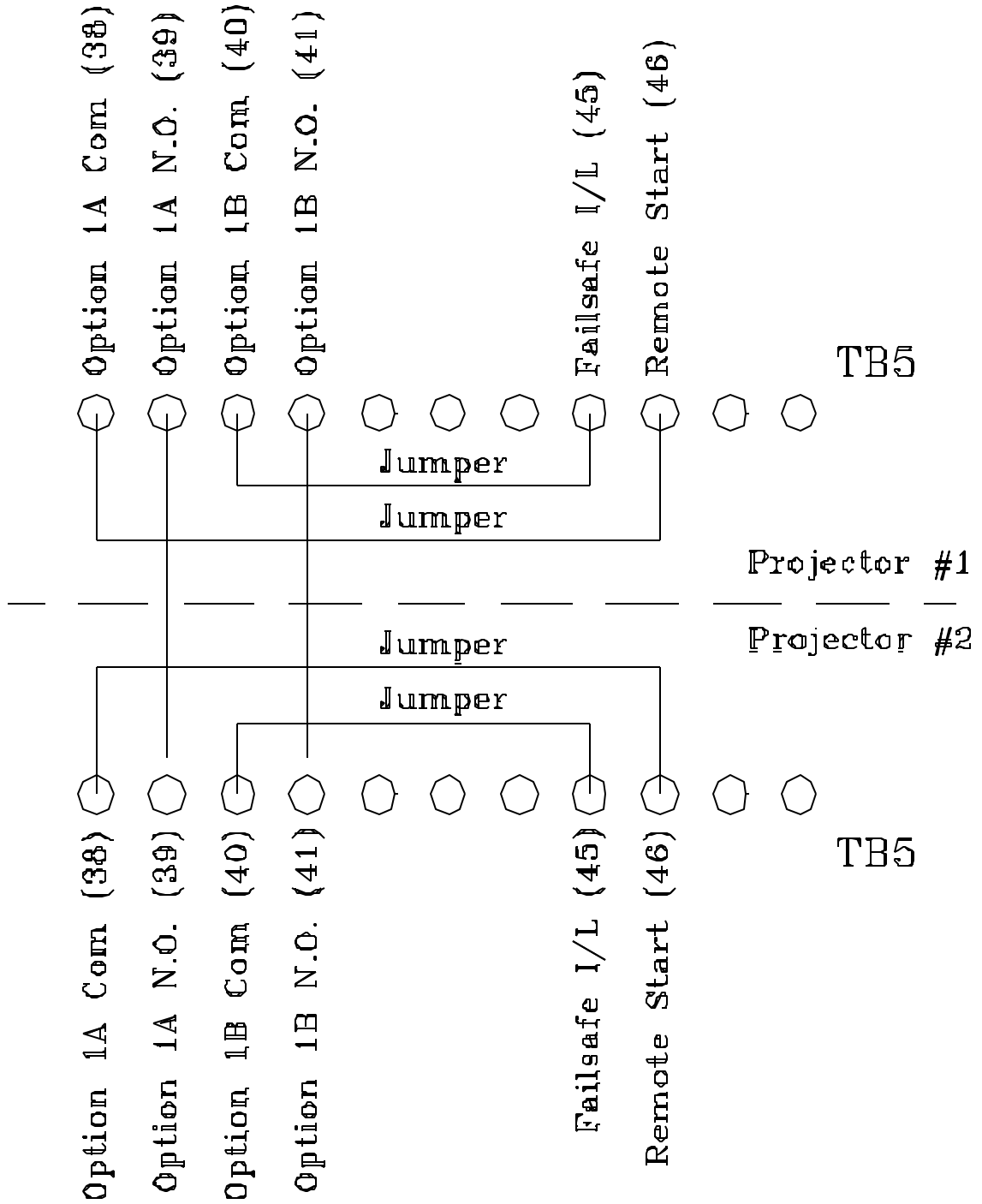

Option 2 Wiring

Independent Masking Control

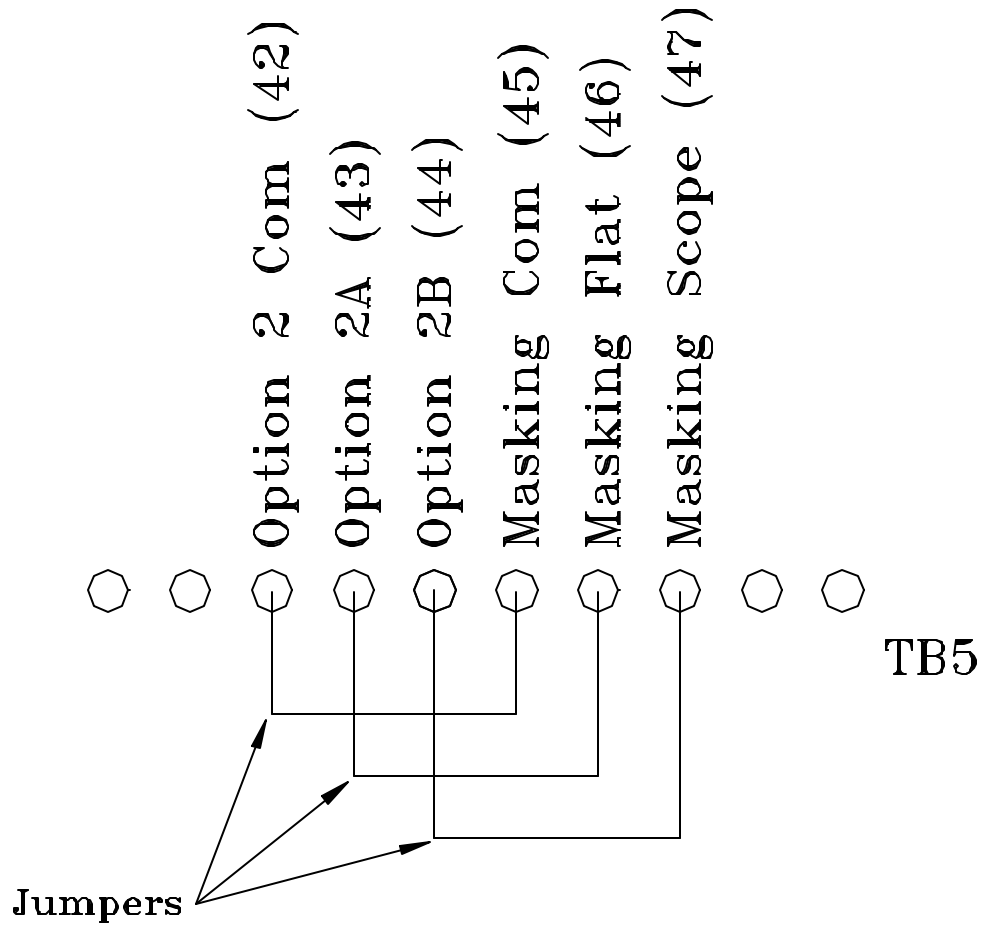

NOTE: Automation will automatically change masking with turret.

Option 2 Wiring

Manual Curtain Control

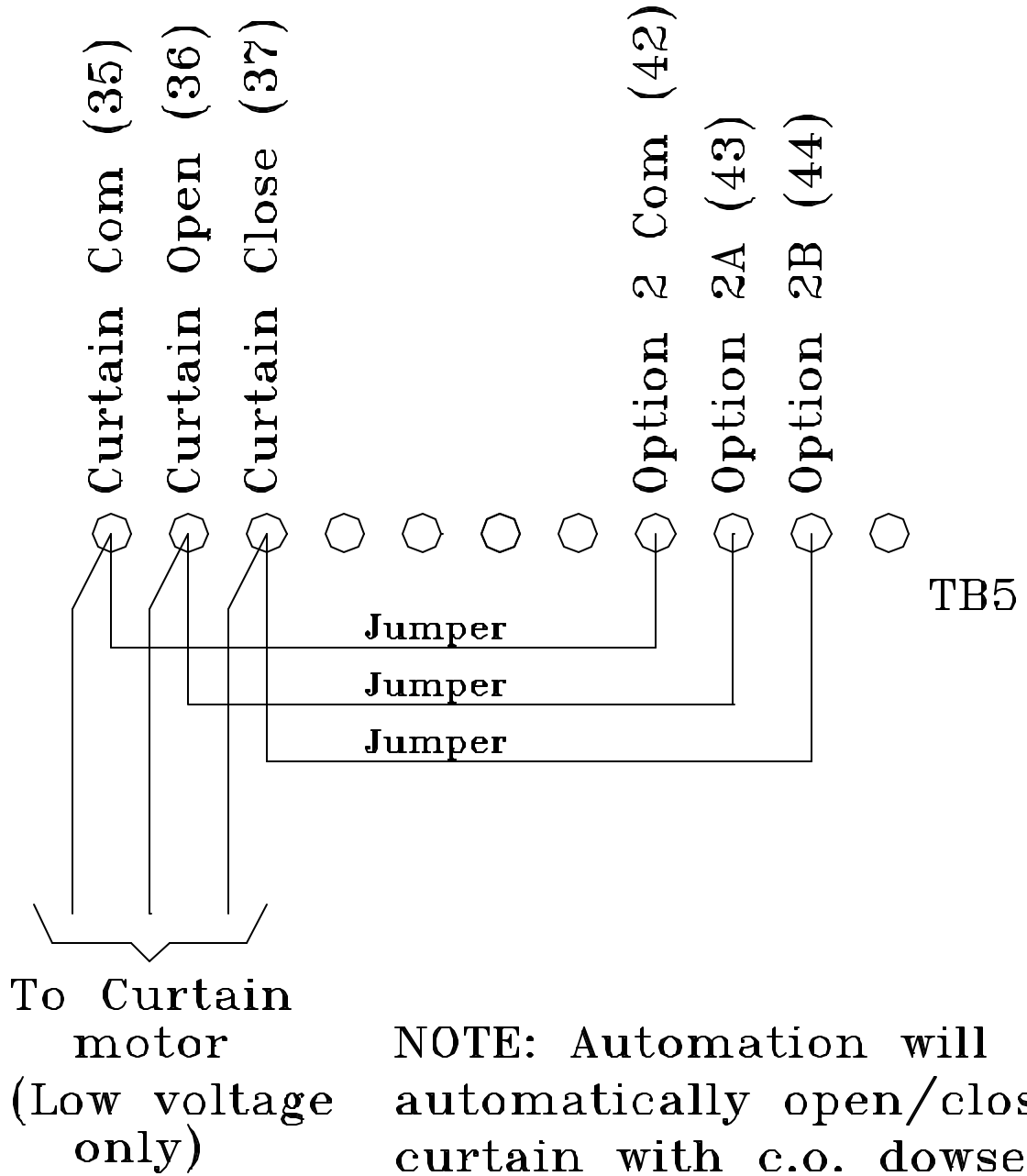

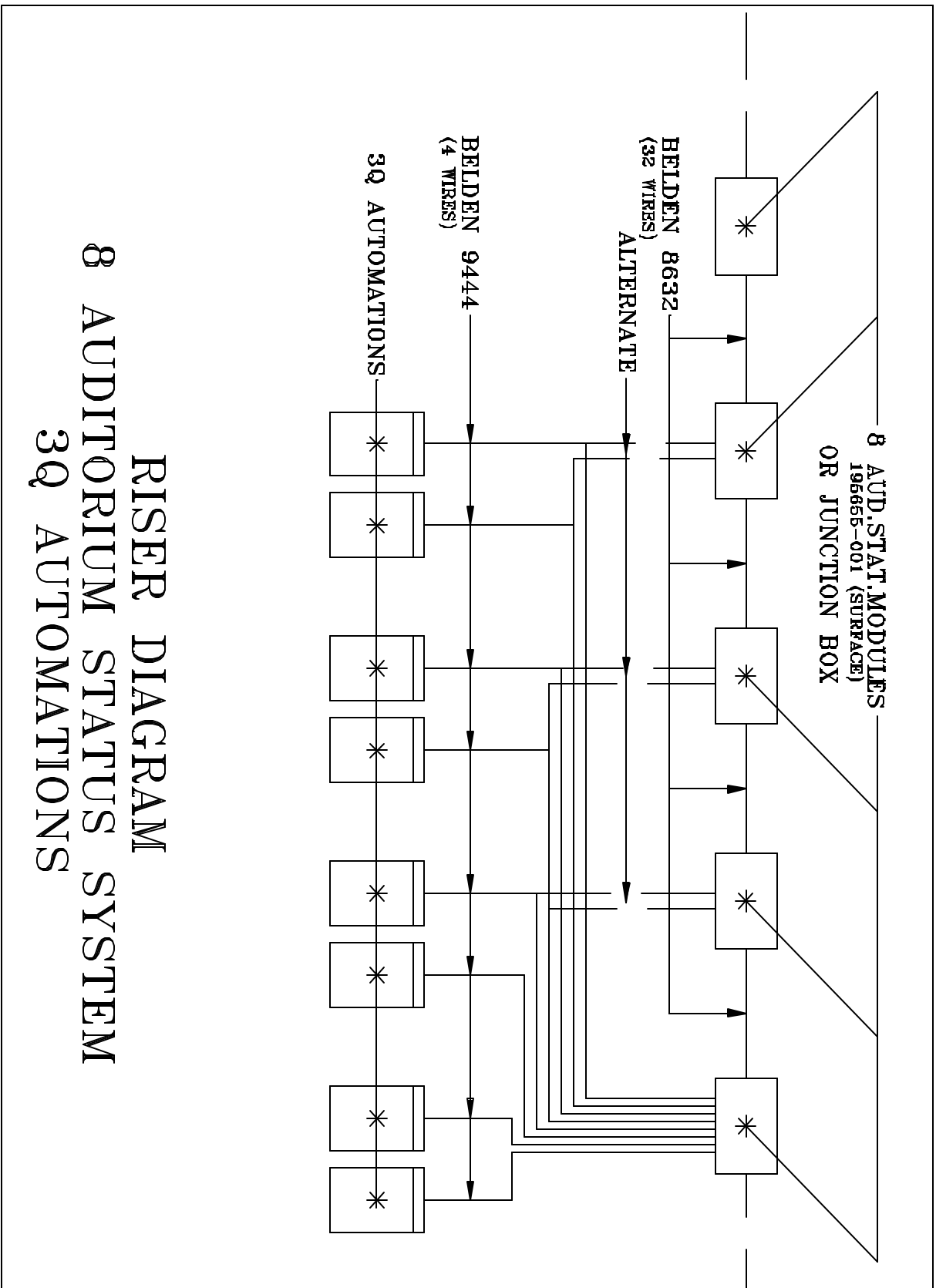

RISE R DIAGRAM
8 AUDITORIUM STATUS SYSTEM
3Q AUTOMATIONS

Phase Check

Two Projector Interlock

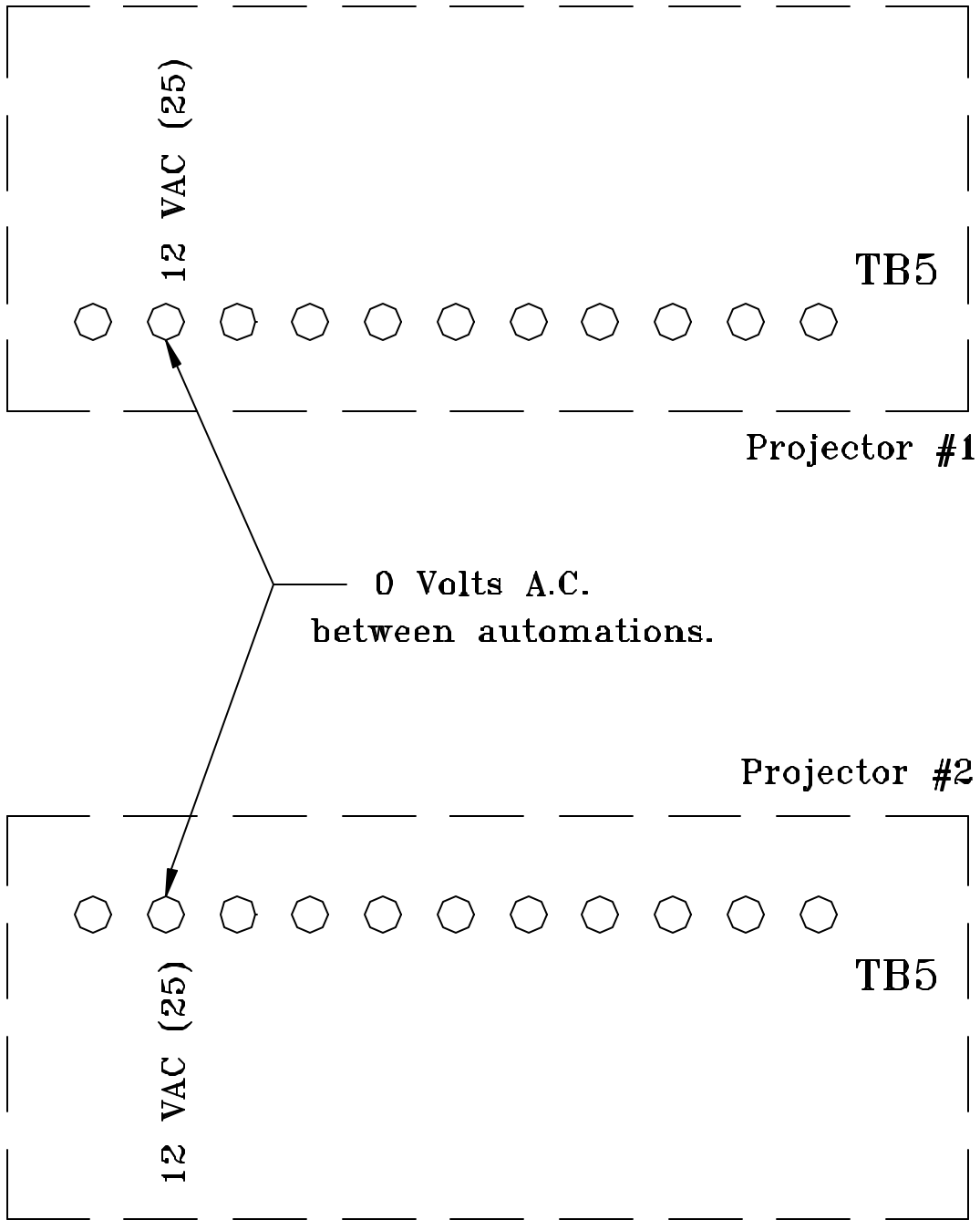

CHRISITE 3Q STATUS INDICATOR

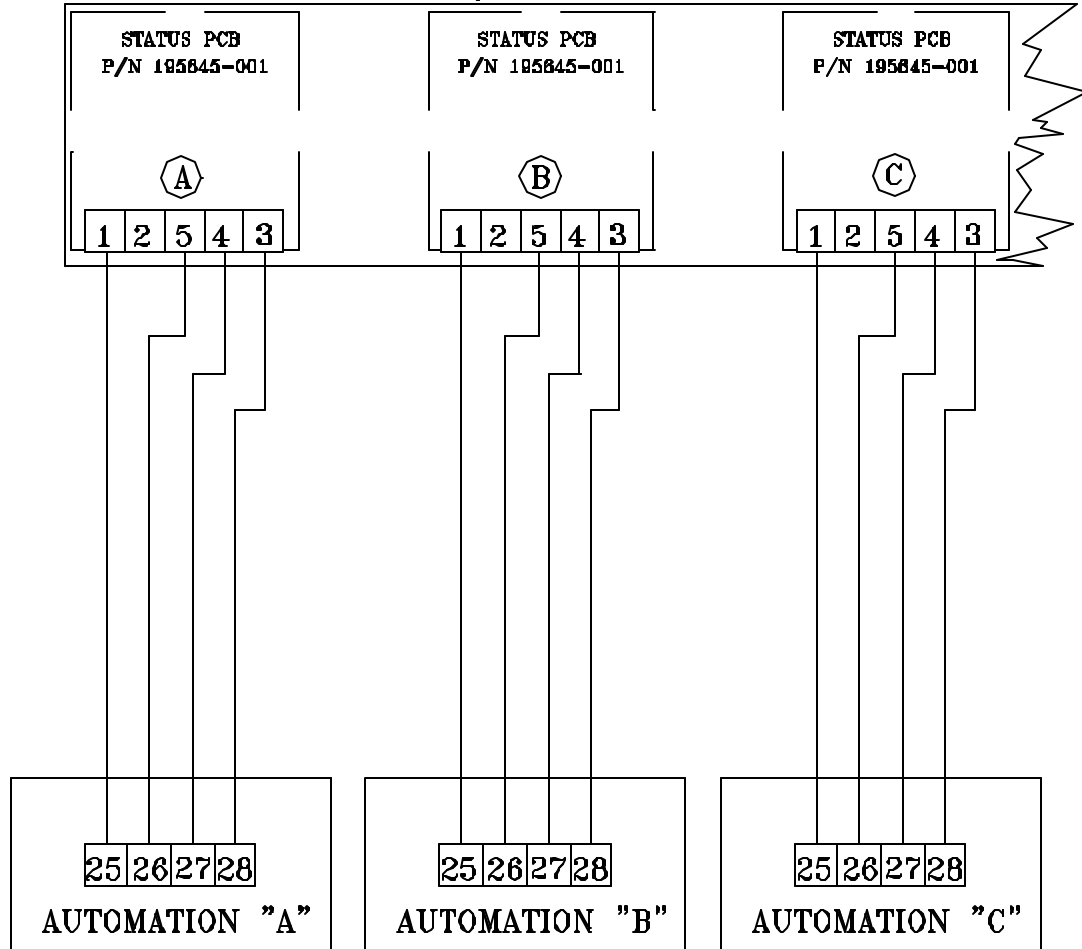

CHRISTIE 3Q STATUS INTERFACE

P.C.B. WIRING TO AUTOMATION MAIN TERMINAL BOARD.

