

Film-Tech

The information contained in this Adobe Acrobat pdf file is provided at your own risk and good judgment.

These manuals are designed to facilitate the exchange of information related to cinema projection and film handling, with no warranties nor obligations from the authors, for qualified field service engineers.

If you are not a qualified technician, please make no adjustments to anything you may read about in these Adobe manual downloads.

www.film-tech.com

SECTION 9

DIAGRAMS FOR CP50

LIST OF DRAWINGS

9.1	Optical pre-amplifier card, Cat. No. 108
9.2	Noise reduction module, Cat. No. 22
9.3	Meter/filter card, Cat. No. 109C
9.4	Link card, Cat. No. 110L
9.5	Link card, Cat. No. 115
9.6	Surround decoder card, Cat. No. 150
9.7	Delay line card, Cat. No. 116B (part of Cat. No. 150)
9.7.1	Block diagram of Surround Decoder
9.7.2	Optical Bass Extension card, Cat. No. 160
9.8	Equalizer module, Cat. No. 64
9.10	Output card, Cat. No. 111
9.11	Remote Fader card, Cat. No. 117
9.11.1	Remote Fader Control Boxes, Cat. Nos. 122 and 123
9.12	Switch card, Cat. No. 112
9.13	Automation Switch card, Cat. No. 113
9.14	Power Supply module, Cat. 114
end of section	Block Diagram of CP50

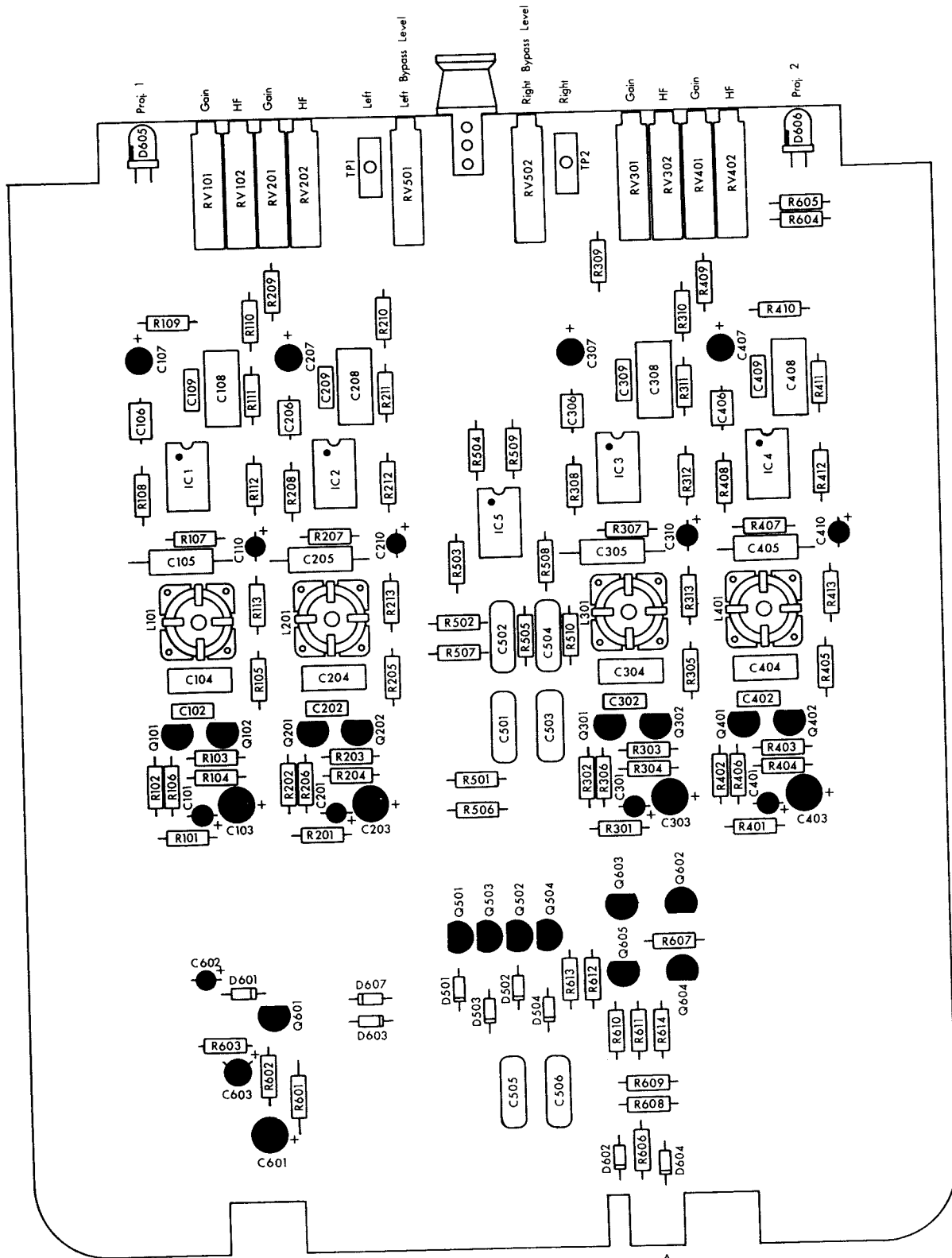

TOPSIDE CONTACTS T
 BOTTOMSIDE CONTACTS 16

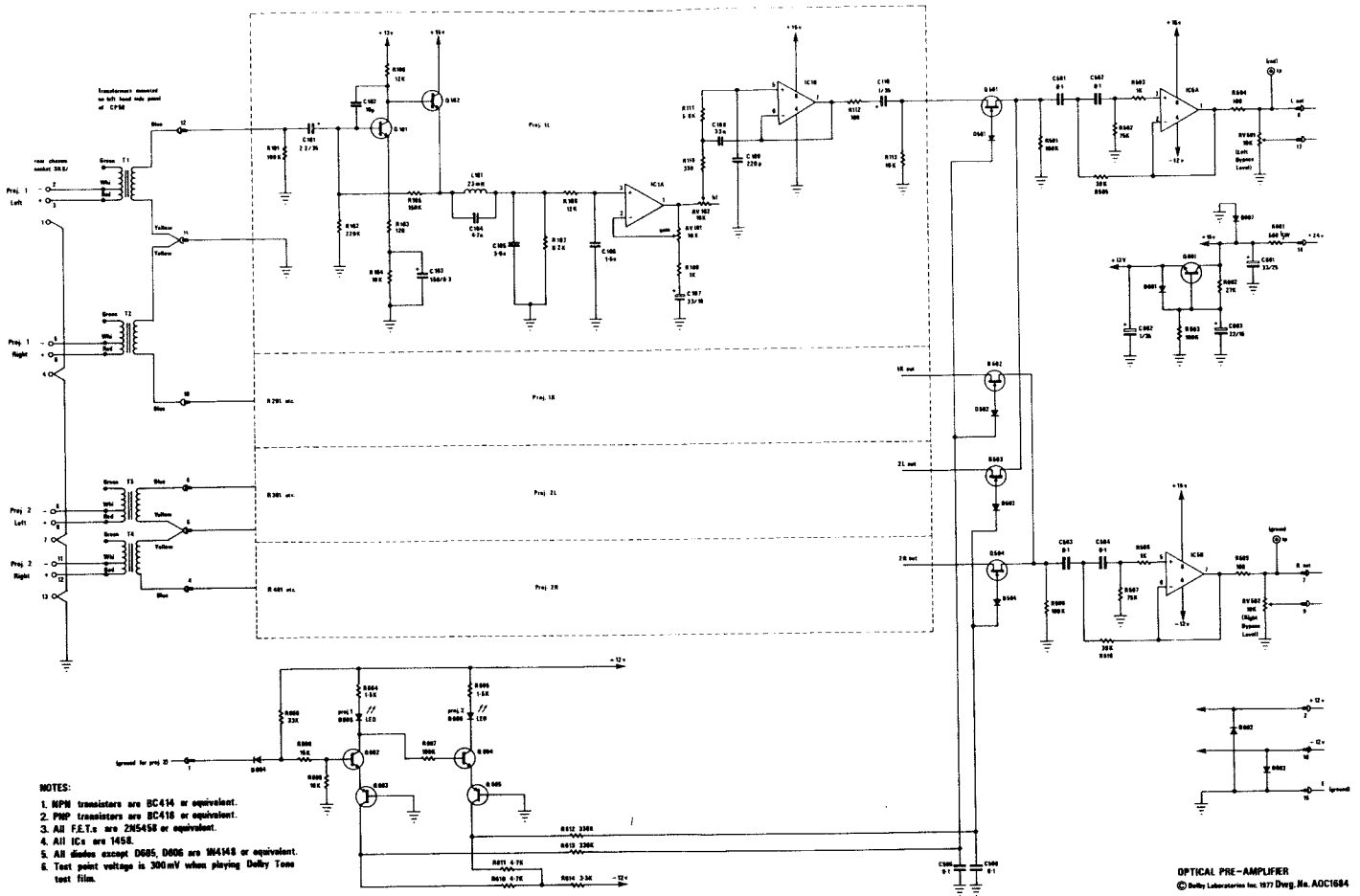

9.1 Optical Pre-Amplifier card, Cat. No. 108

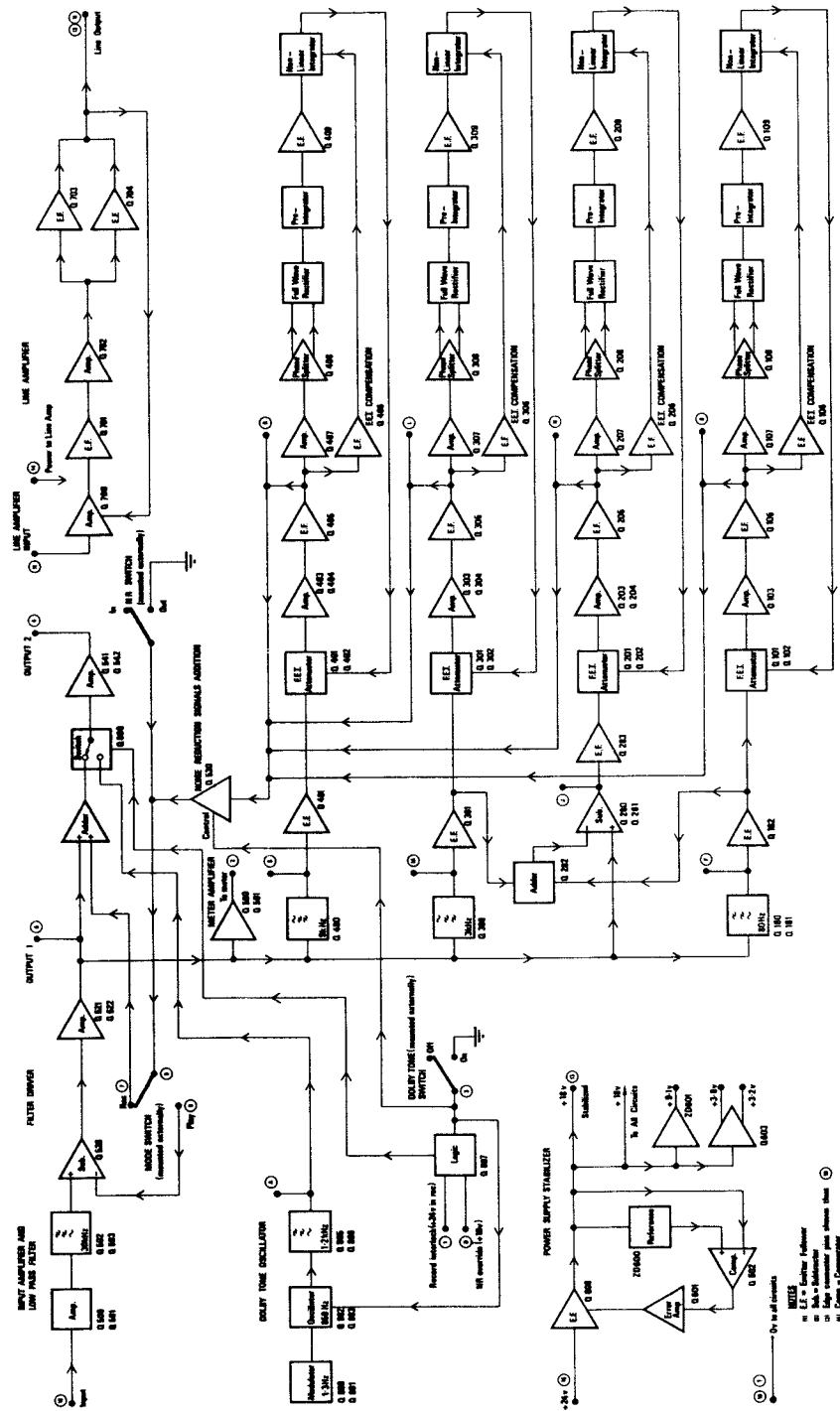

© See comments on Drawing No. AMP 441 CAT 22 NOISE REDUCTION MODULE BLOCK DIAGRAM

The Cat. No. 22 Noise Reduction module (NRM) is covered in full detail in Section 10; the block diagram above is included here for convenience only. No user-serviceable parts; modules are serviced by exchange by distributors or factory.

Cat. No. 109-C A22PM12226

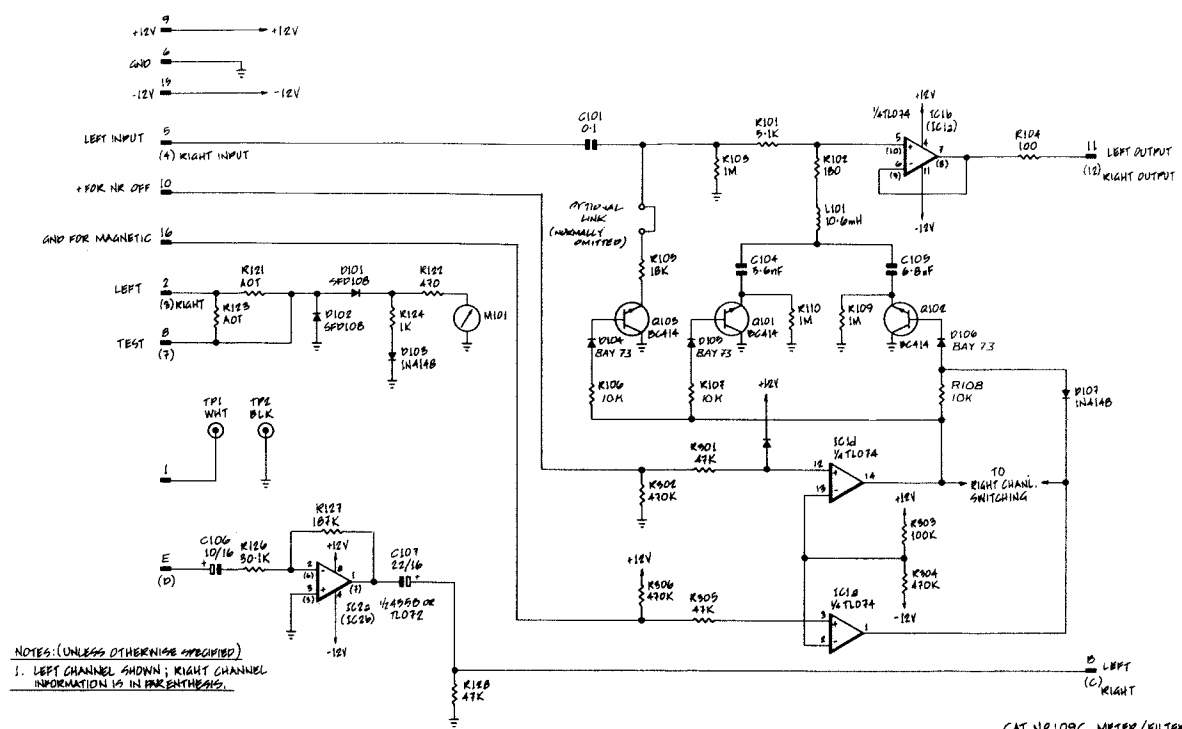

NOTES: (UNLESS OTHERWISE SPECIFIED)
1. LEFT CHANNEL SHOWN; RIGHT CHANNEL INFORMATION IS IN PARENTHESES.

CAT. NO. 109C METER/FILTER CARD
© DOLBY LABORATORIES INC. 1980 ORIG. NO. A10206, ISSUE 3

key ⑫

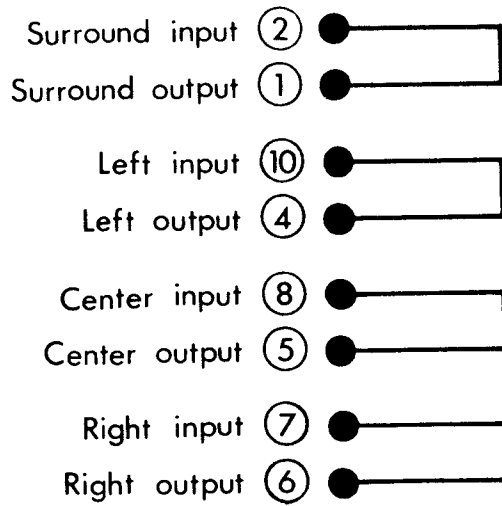

LINK CARD

© Dolby Laboratories Inc. 1977 Dwg. No. A4C1687

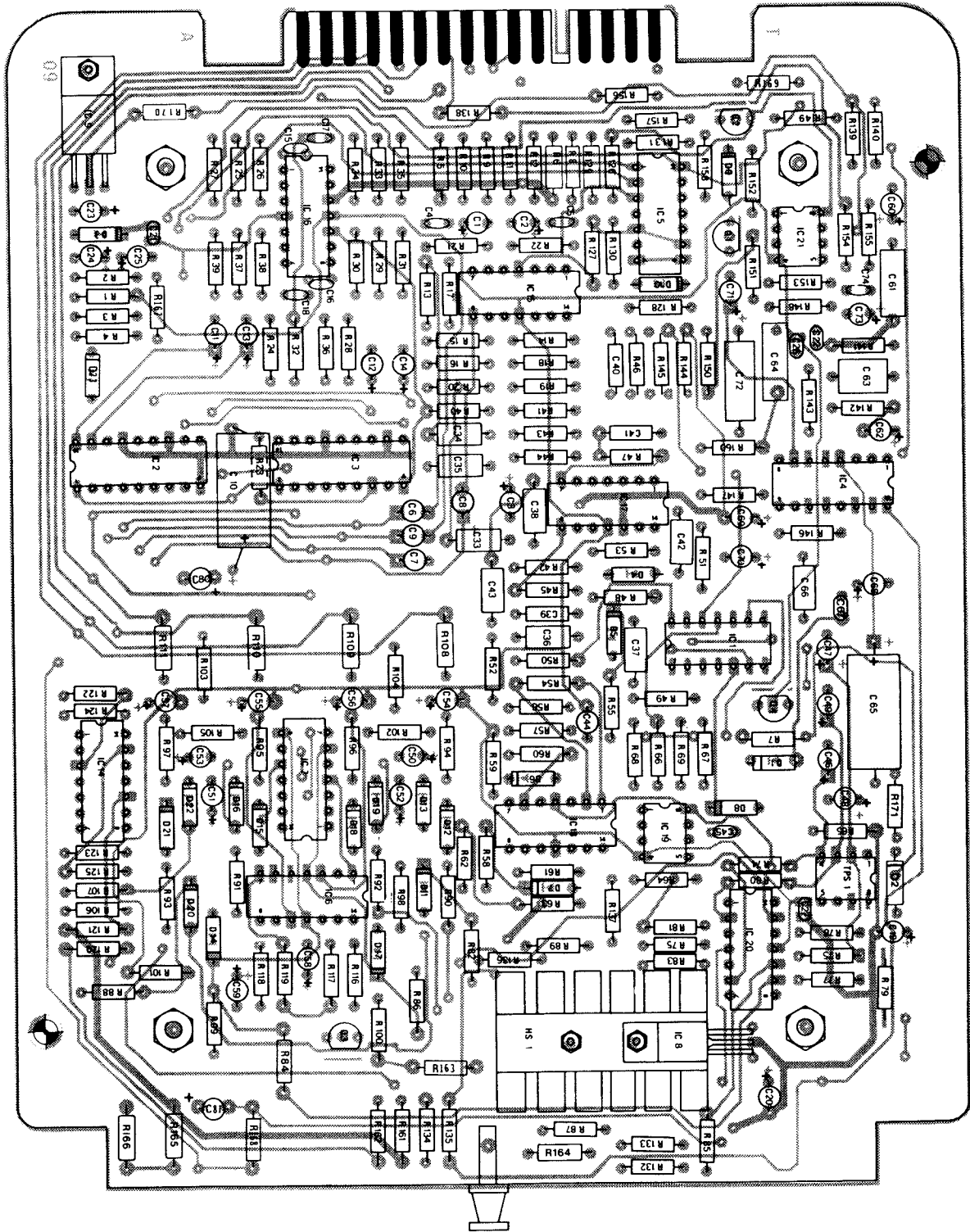

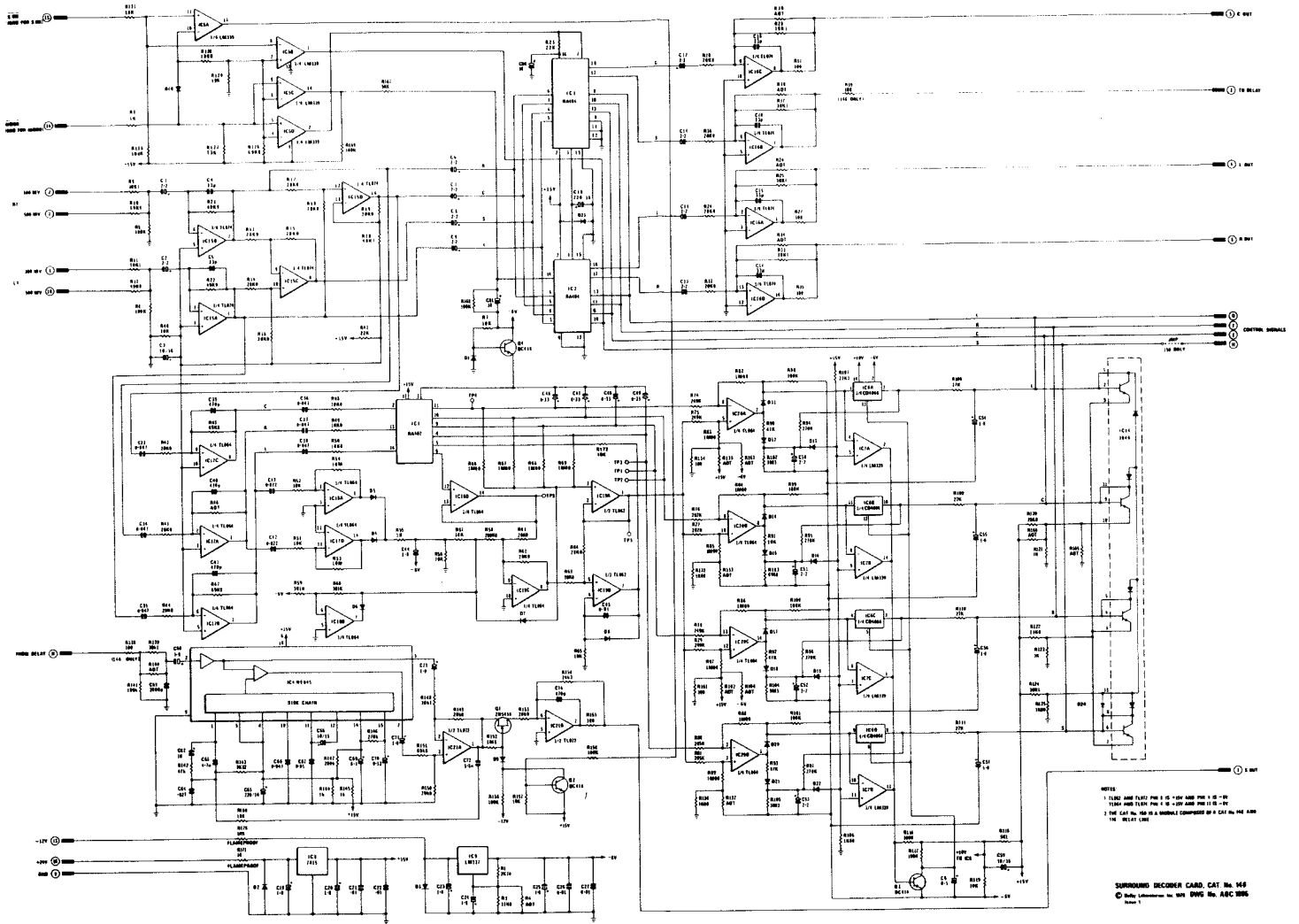

NOTES
 1. FLANGER AND PHASER PINS 1 & 2: +12V AND PINS 3 & 4: -12V
 2. THE CAT. NO. 146 IS A SUBCIRCUIT COMPONENT OF P. CAT. NO. 145
 THE 801-100

SURROUND DECODER CARD, CAT. No. 146
 © 1984, International Technology, INC. DWS No. ABC 005
 Rev. 1

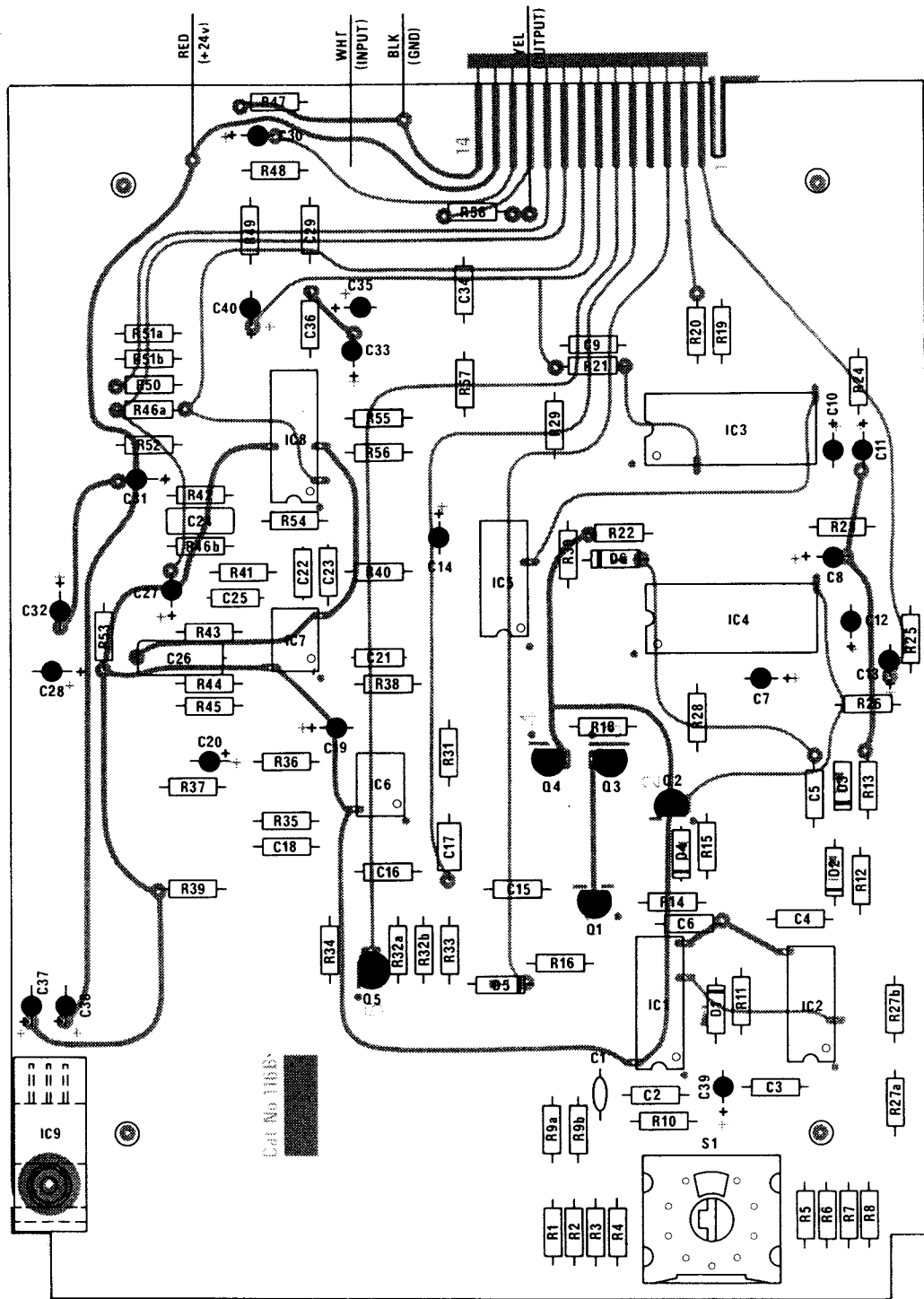

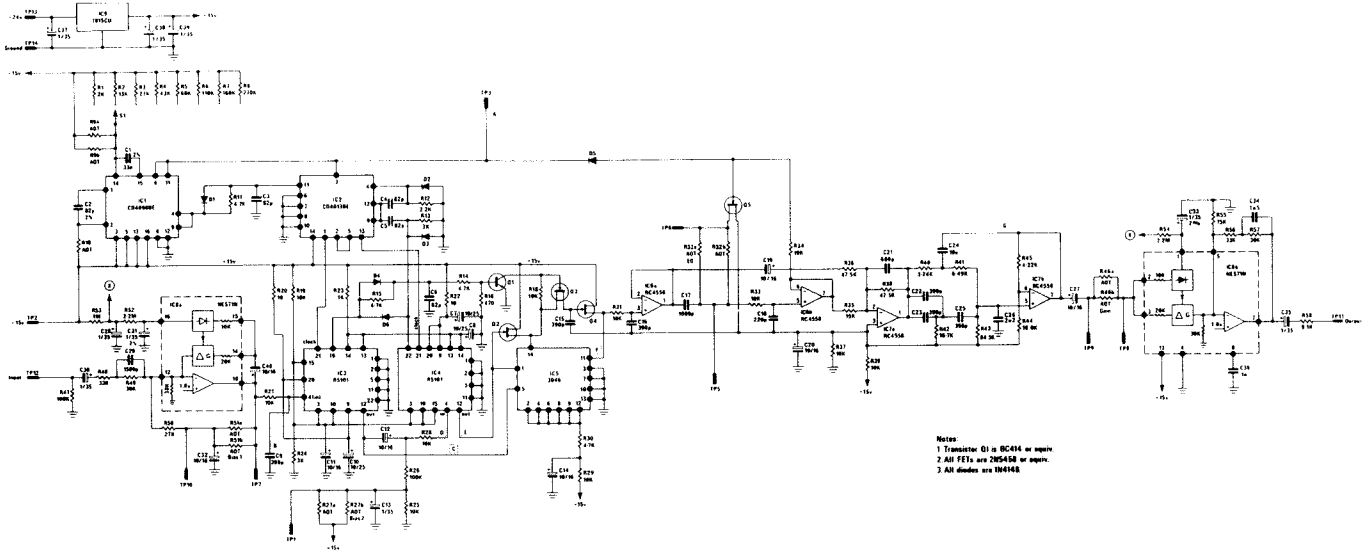

Notes:
 1 Transistor Q1 is BC410 or equiv.
 2 All FETs are 2N5450 or equiv.
 3 All diodes are 1N6148.

DELAY LINE CARD © Bell Laboratories Inc. 1977 Desig. No. ABC178
 Issue 1

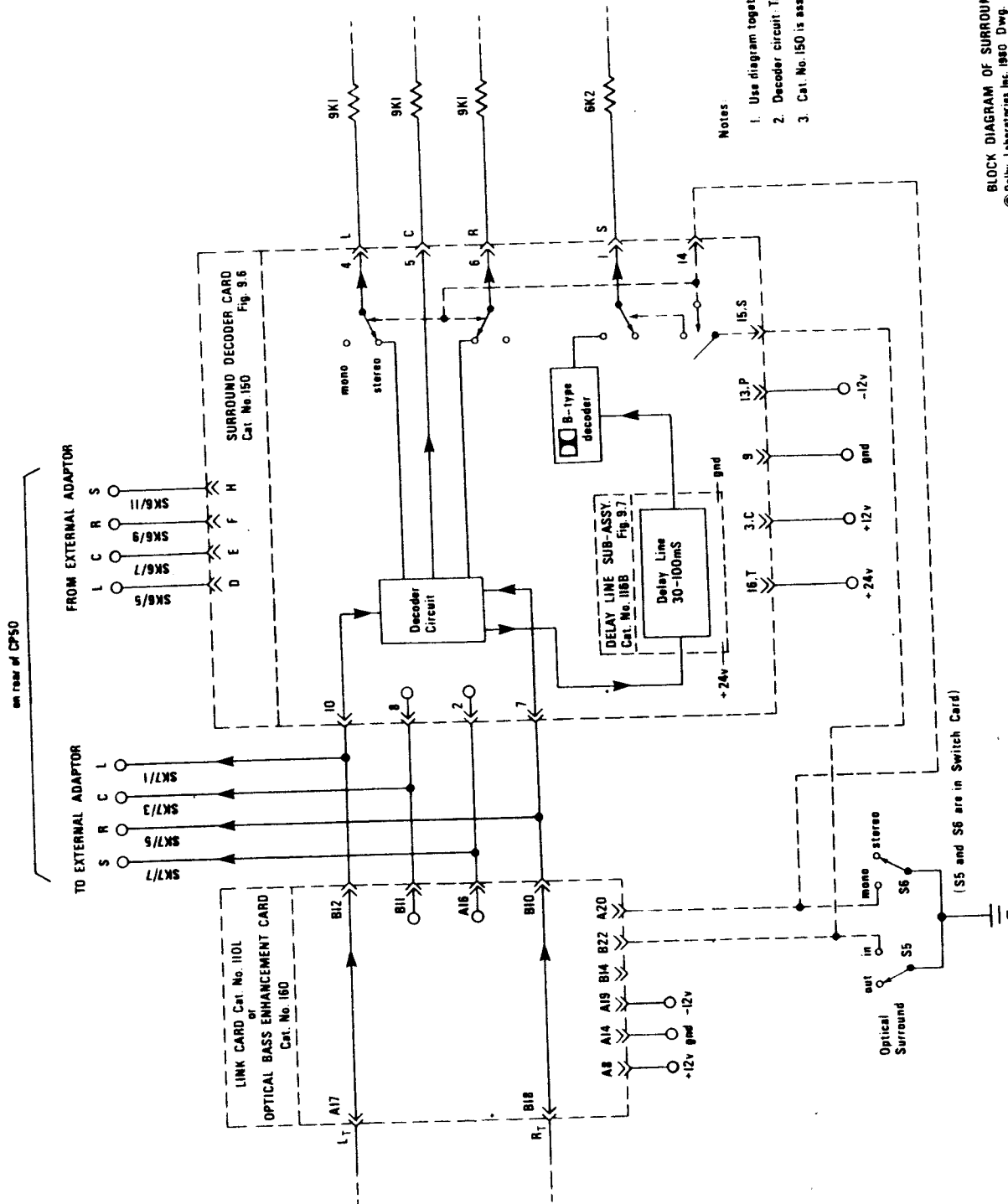

Notes:

1. Use diagram together with CP50 block diagram at
2. Decoder circuit: Tate DES system
3. Cat. No. 150 is assembly of Cat. Nos. 146 and 116B.

BLOCK DIAGRAM OF SURROUND DECODING SYSTEMS IN CP50
 © Delby Laboratories Inc. 1980 Dwg. No. A282218
 Circuit patent protected.

Fig. 9.7.1 Block diagram of Surround Decoder

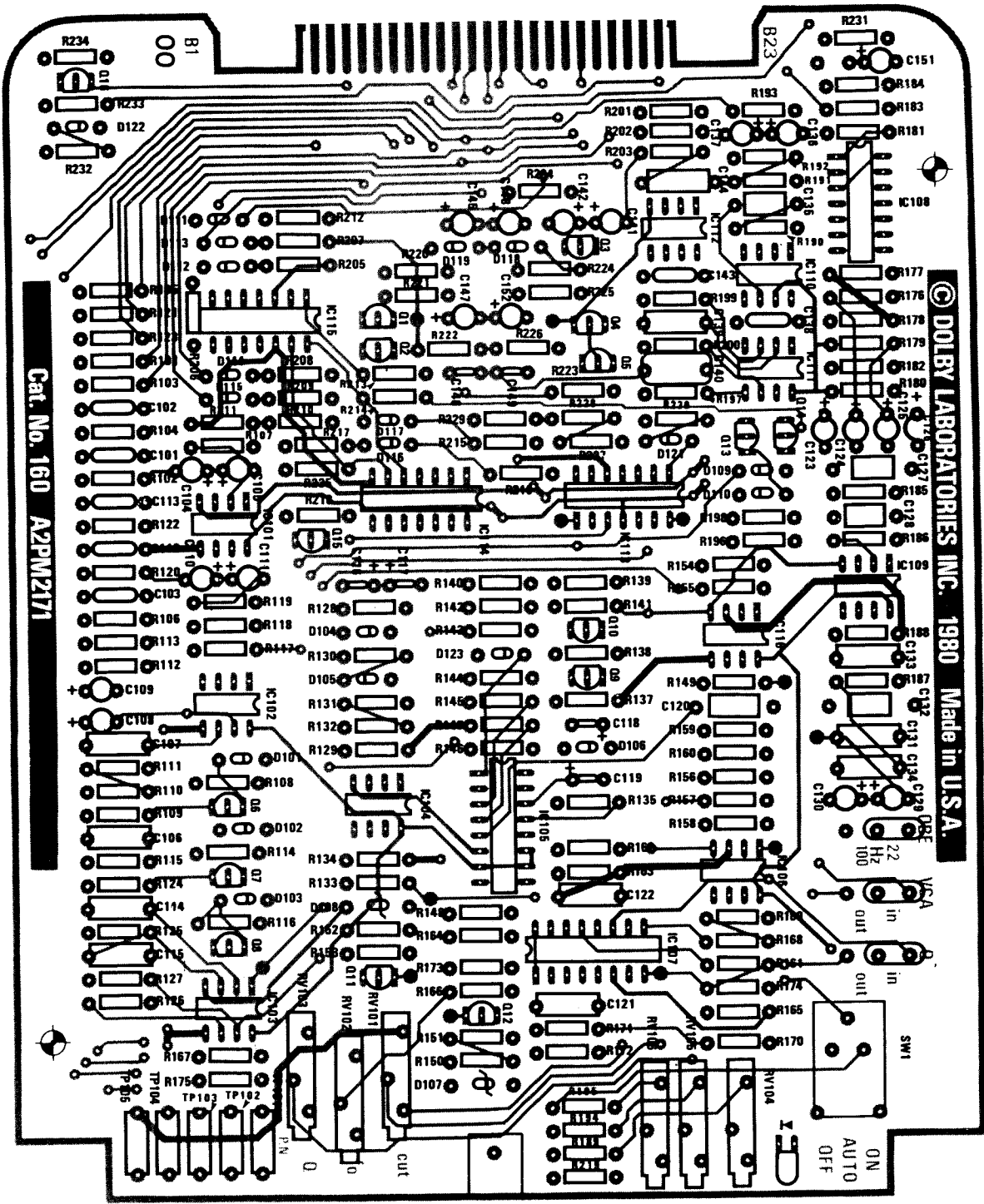

Cat. No. 160 A2PM271

© DOLBY LABORATORIES INC. 1980 Made in U.S.A.

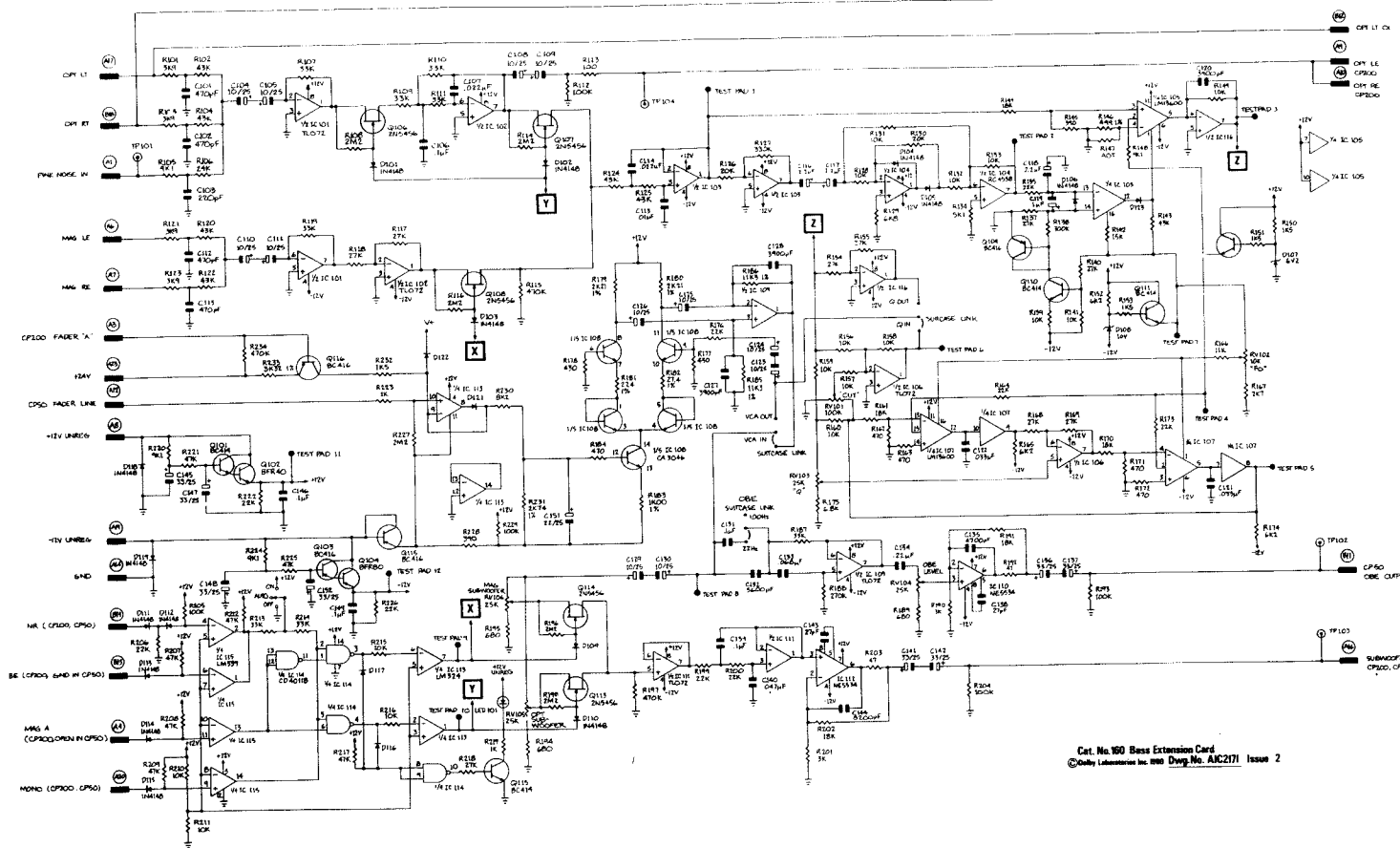

Cat. No. 160 Bass Extension Card
 ©Daly Laboratories Inc. 1980 Dwg. No. AC2171 Issue 2

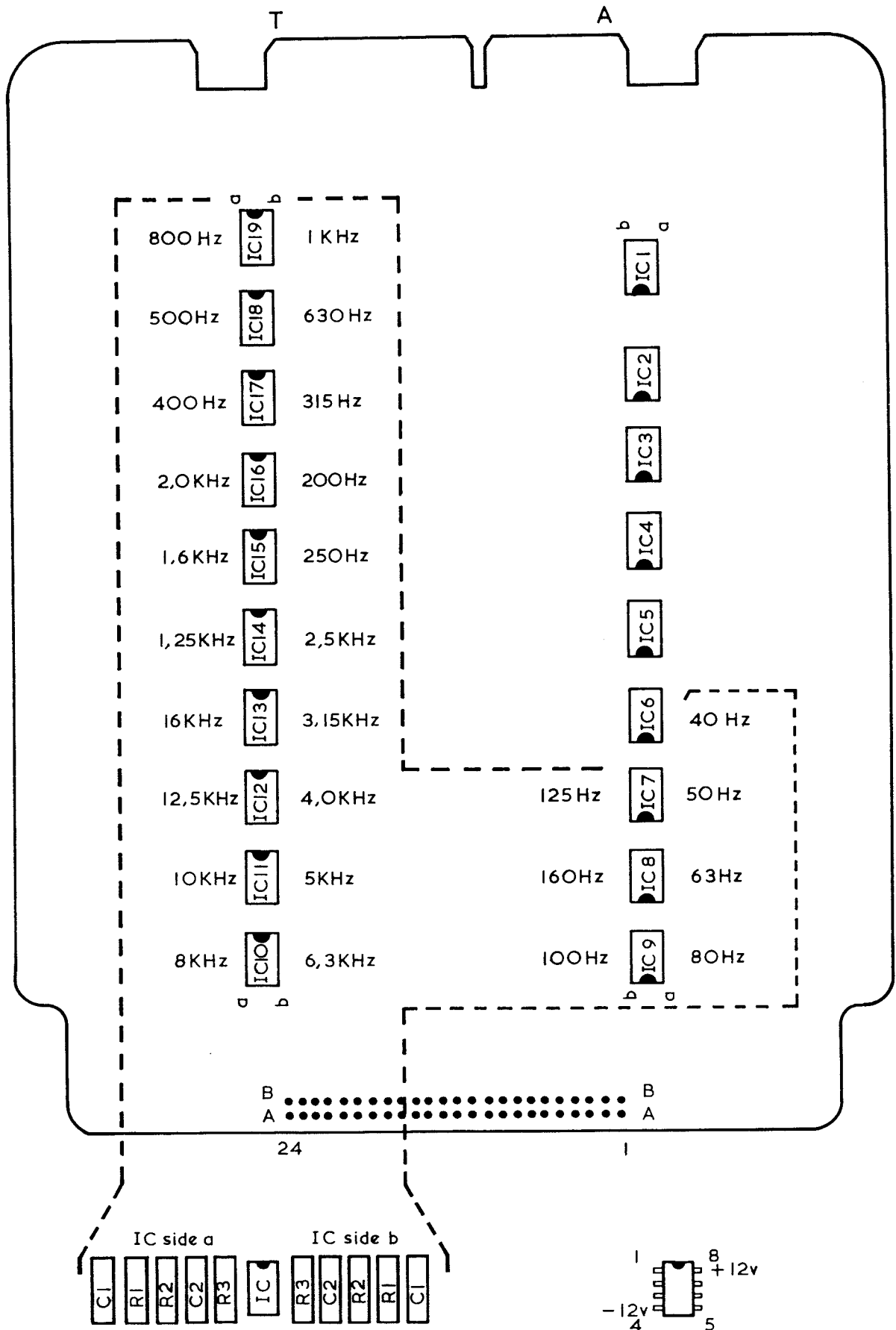

Filter circuit component layout

IC pin numbers

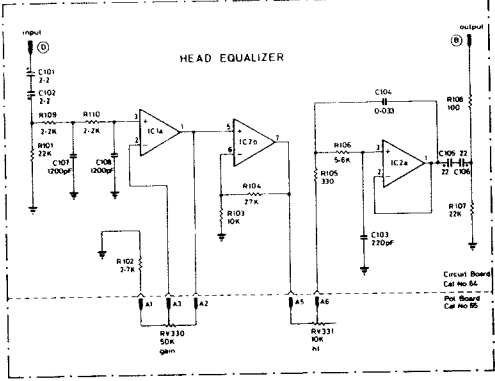

FILTER DATA

Frequency Hz	40	50	63	80	100	125	160	200	250	315	400	500	630	800	1k	1.25k	1.6k	2k	2.5k	3.15k	4k	5k	6.3k	8k	10k	12.5k	16k
R1	90.9k	71.5k	53.6k	45.3k	35.7k	33.3k	73.2k	53.0k	48.4k	37.4k	60.4k	48.7k	38.3k	30.3k	78.7k	63.4k	49.9k	39.2k	31.6k	53.6k	42.2k	33.2k	26.1k	43.2k	34.6k	27.4k	21.0k
R2	182k	143k	115k	90.9k	71.5k	67.7k	147k	118k	93.3k	75k	121k	97.6k	76.8k	60.4k	158k	127k	100k	78.7k	63.4k	107k	83.4k	65.5k	52.3k	86.6k	69.4k	54.9k	42.2k
R3	1.82k	1.43k	1.15k	909	715	1.67k	1.47k	1.18k	931	750	1.21k	976	768	604	1.58k	1.27k	1.00k	787	634	1.07k	834	655	523	866	694	549	422
C1/C2	-.22µ	-.22µ	-.22µ	-.22µ	-.22µ	-.068µ	-.068µ	-.068µ	-.068µ	-.033µ	-.033µ	-.033µ	-.033µ	-.033µ	-.01µ	-.01µ	-.01µ	-.01µ	-.01µ	-.01µ	-.01µ	-.01µ	-.01µ	-.01µ	-.01µ	-.01µ	-.01µ
C.64/65 Interconnections	B1	B2	B3	B4	B5	B7	B6	B8	B9	A22	B22	B23	A23	B24	A24	B19	B20	B21	B40	B11	B12	B13	B14	B5	B16	B17	B18
C.54 IC number	60	70	80	90	90	70	80	160	150	170	170	180	180	190	190	140	150	160	140	130	120	110	100	100	110	120	130
C.65 Comp. #	301	302	303	304	305	306	307	308	309	310	311	312	313	314	315	316	317	318	319	320	321	322	323	324	325	326	327

- NOTES**
- All filter capacitors 7.2%
 - All filter resistors 1.1%
 - On Cat. No. 64/65 interconnector, the X tags connect with component side of Cat. No. 64, non-component side of Cat. No. 65, and pin 1 nearest head equalizer stripmate on Cat. No. 65.
 - Pins marked thus (A) plug into the chassis edge connector.
 - Working voltage of all capacitors 16 volts minimum.
 - D.C. level at output of all amplifiers 0 volts approx.
 - All integrated circuits are 1458 or equivalent (about operational amplifiers).

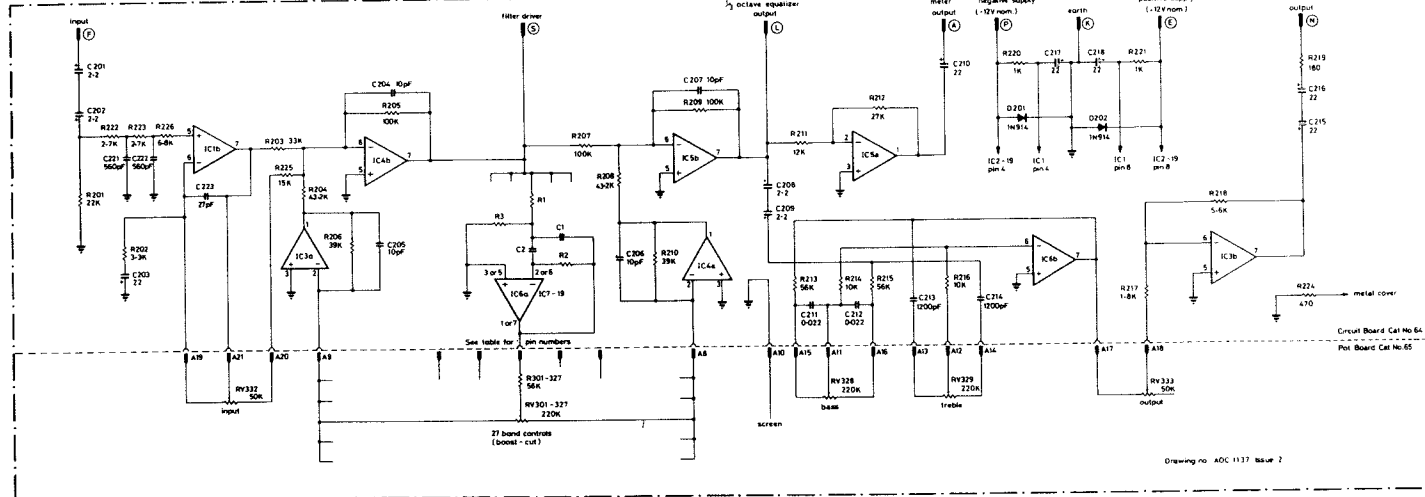

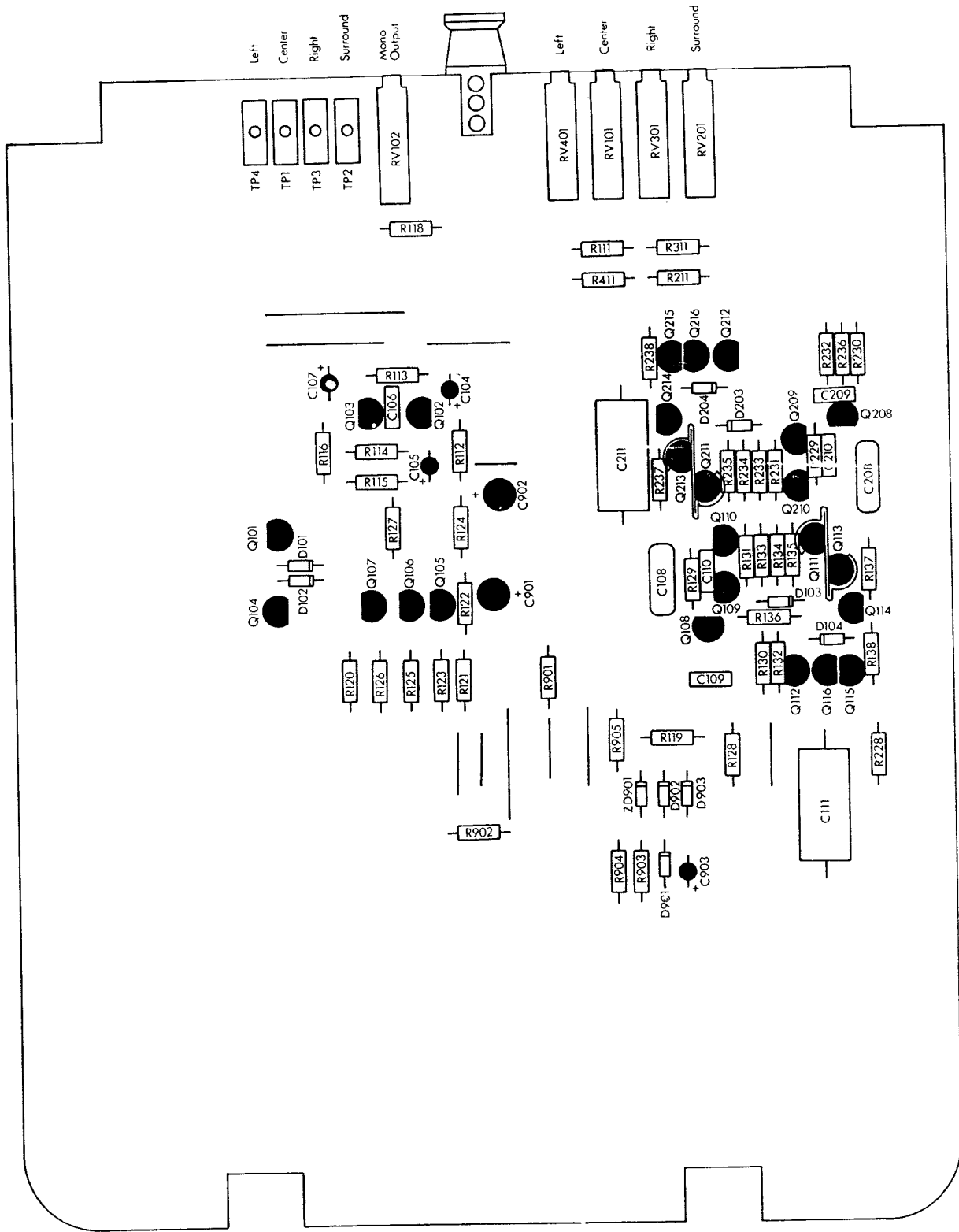

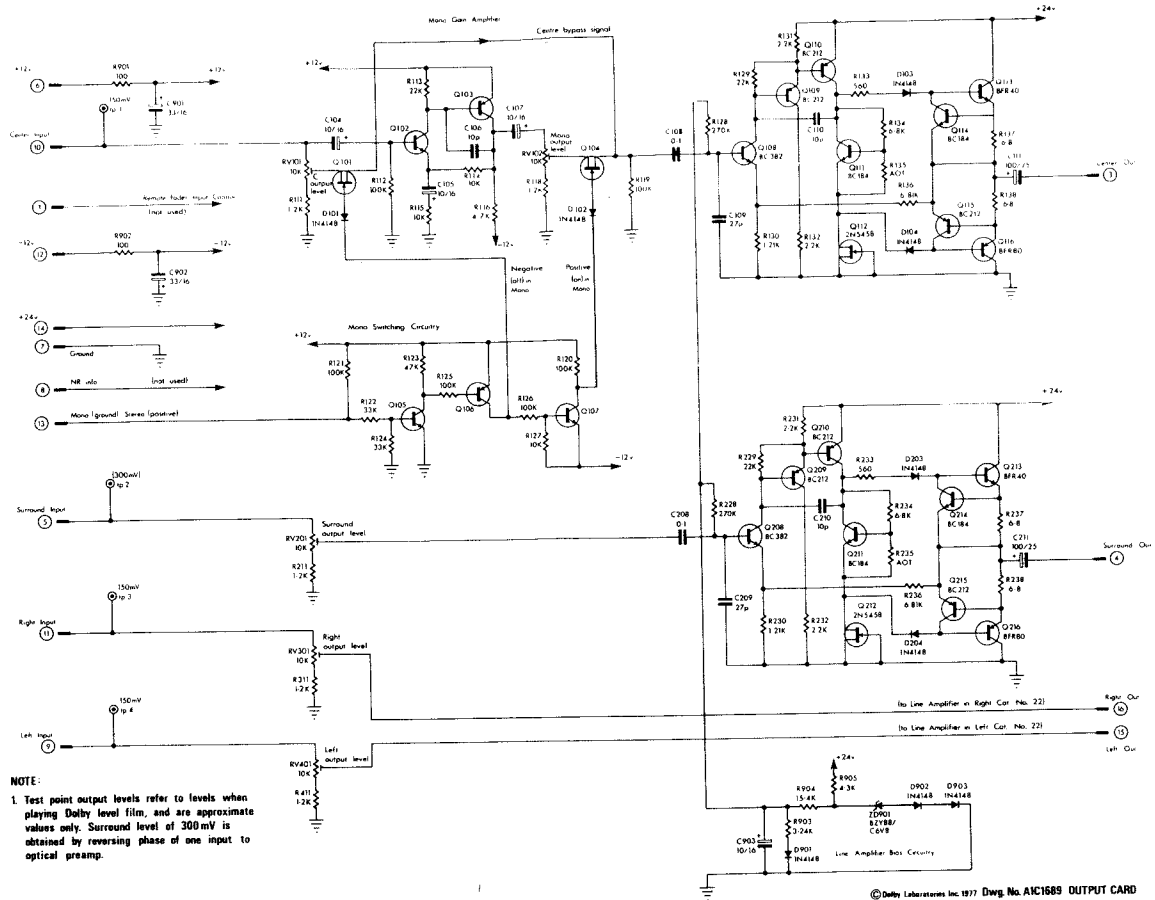

9.10 Output card, Cat. No. 111

© DOLBY LABORATORIES INC. 1980 Made in England

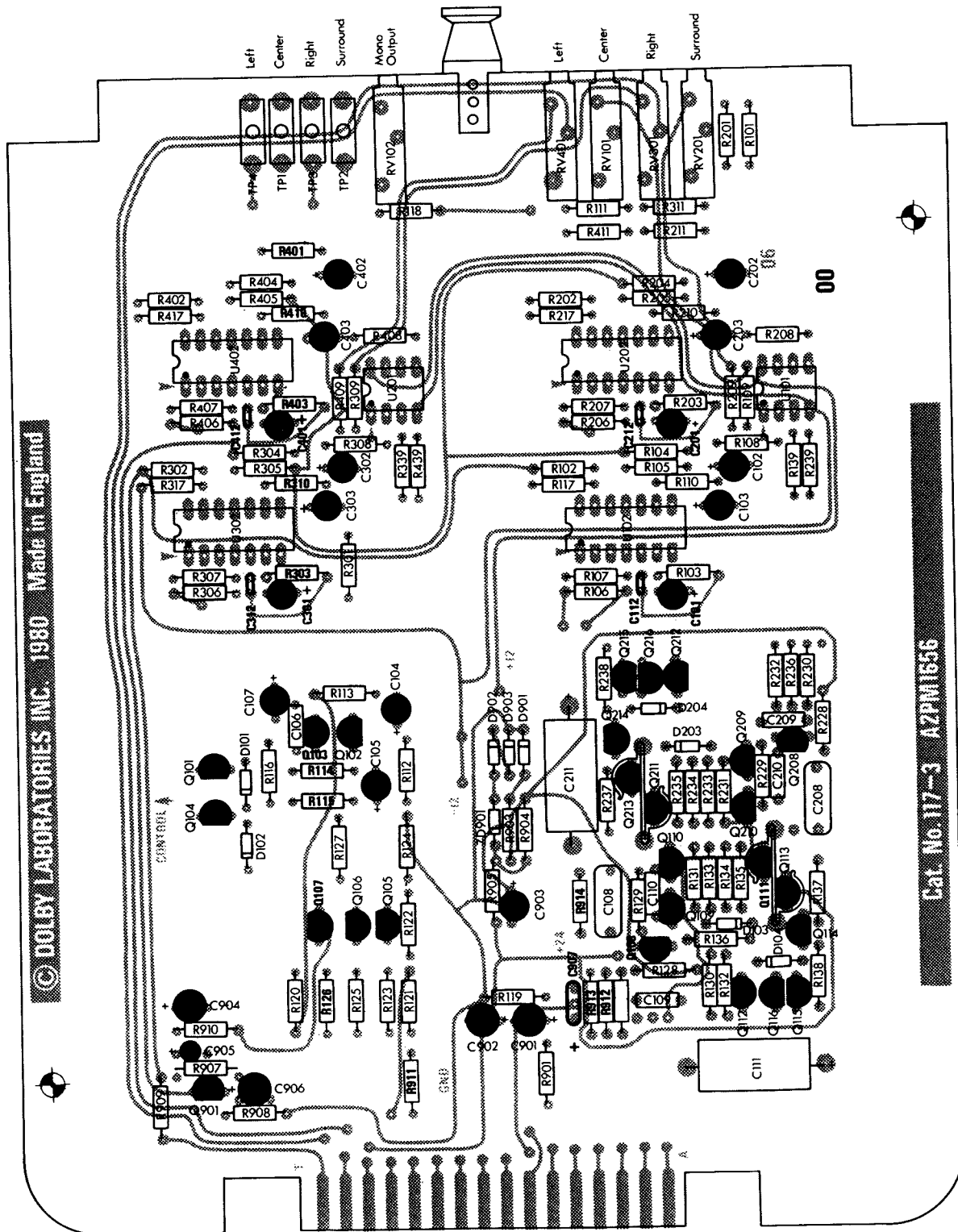

Cat. No. 117-3 AZPM1556

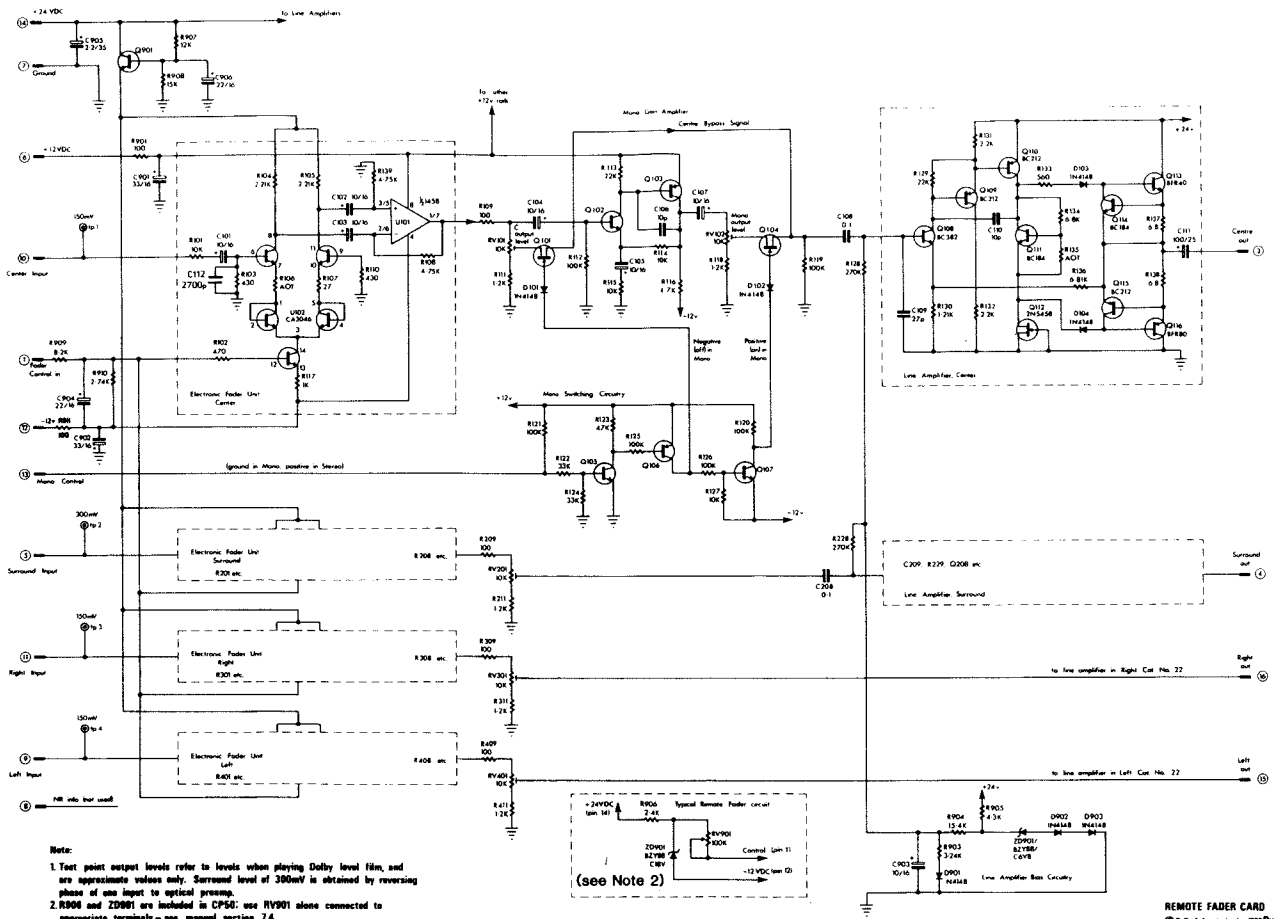

S81/237/3490

9.11 Cat. No. 117 Remote fader card

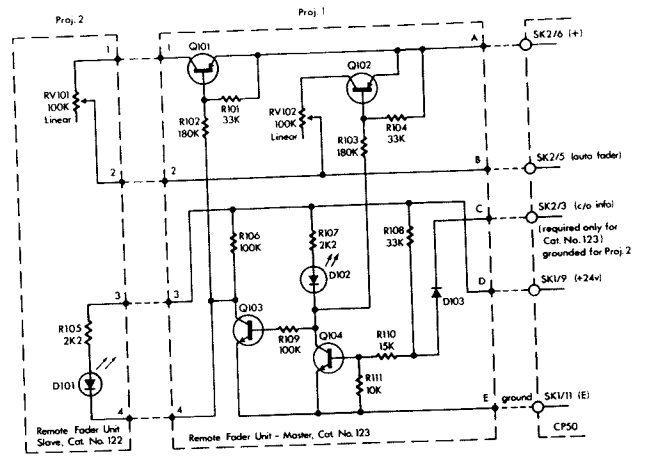
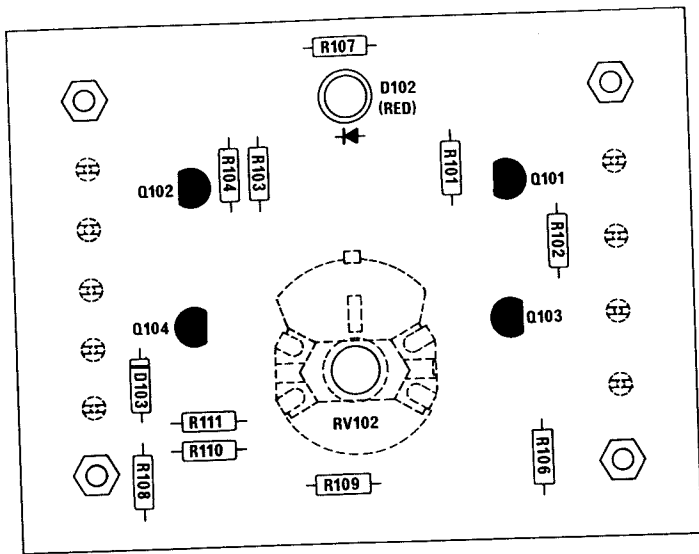

Note:
 1. Shown for 2-station installation. For single station, Cat. No. 122 is connected directly to CP50, see manual page 7-20.

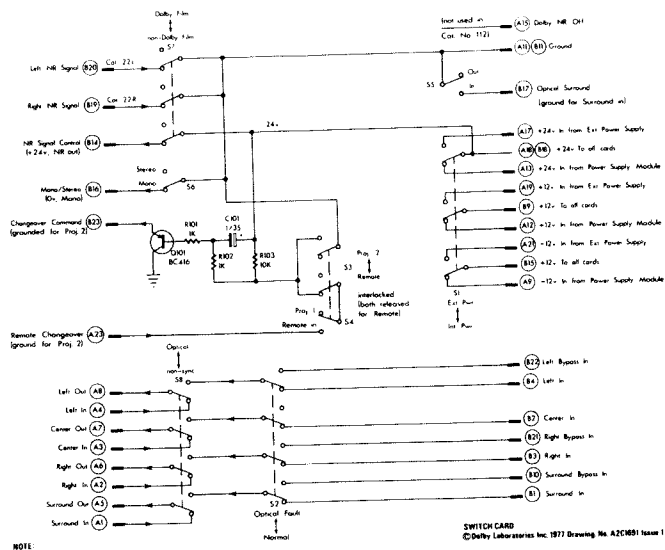
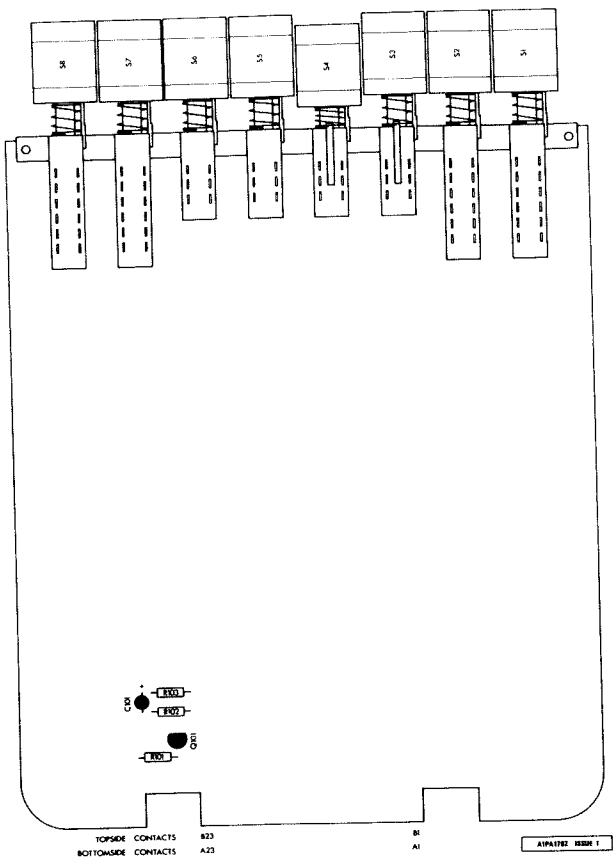

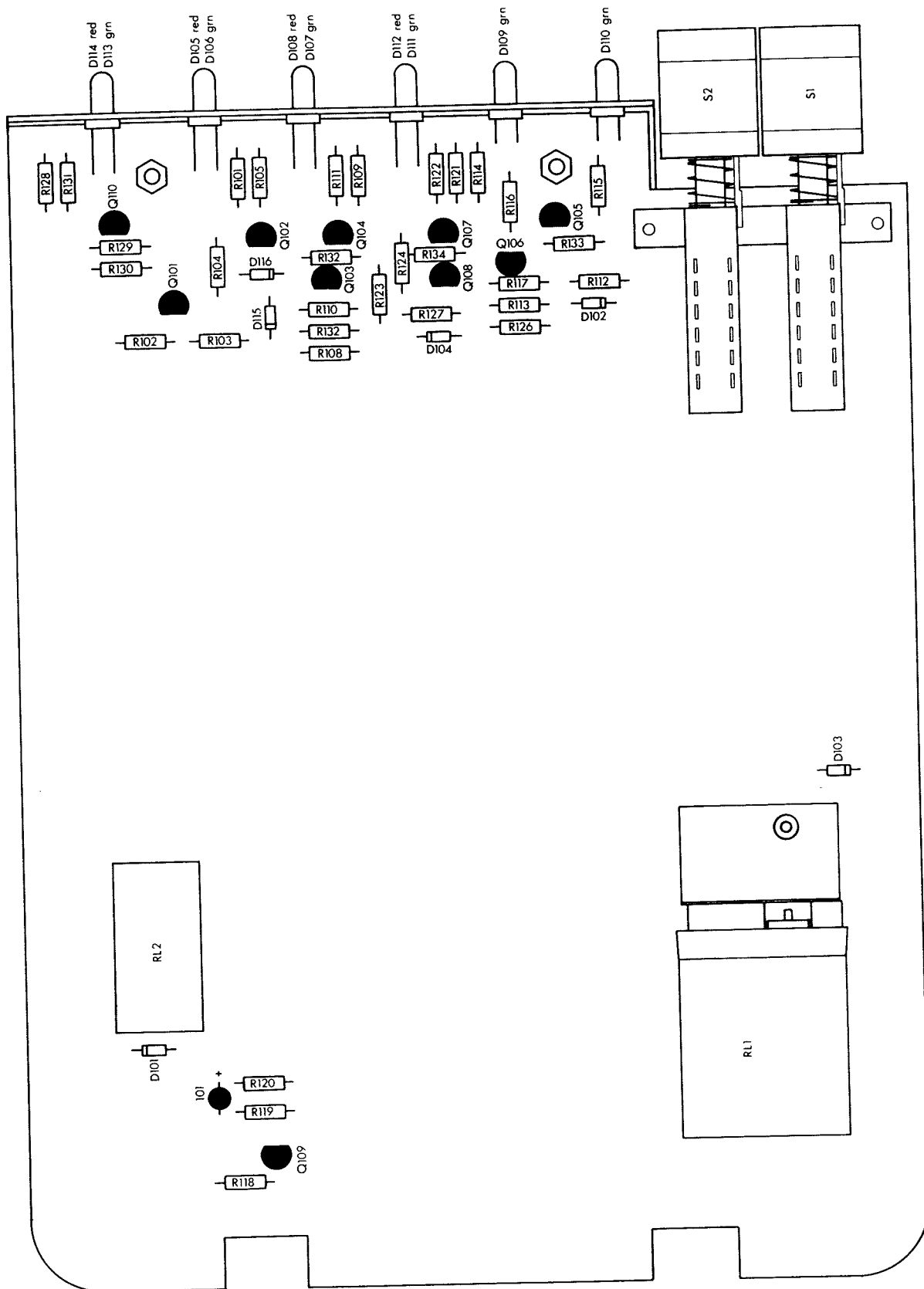

TOPSIDE CONTACTS B23
 BOTTOMSIDE CONTACTS A23

B1
 A1

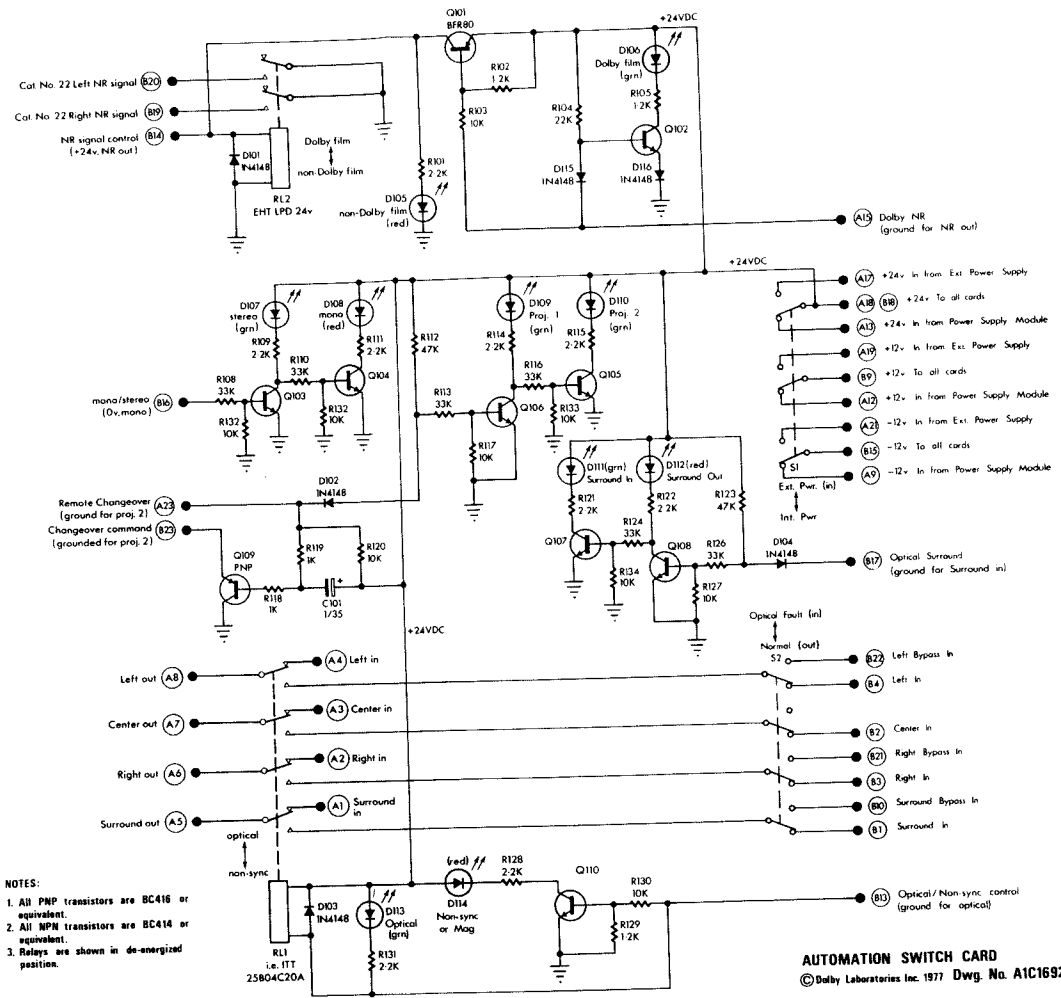

- NOTES:
1. All PNP transistors are BC416 or equivalent.
 2. All NPN transistors are BC414 or equivalent.
 3. Relays are shown in de-energized position.

AUTOMATION SWITCH CARD
 ©Dolby Laboratories Inc. 1977 Dwg. No. A1C1692

9.13 Automation Switch card, Cat. No. 113

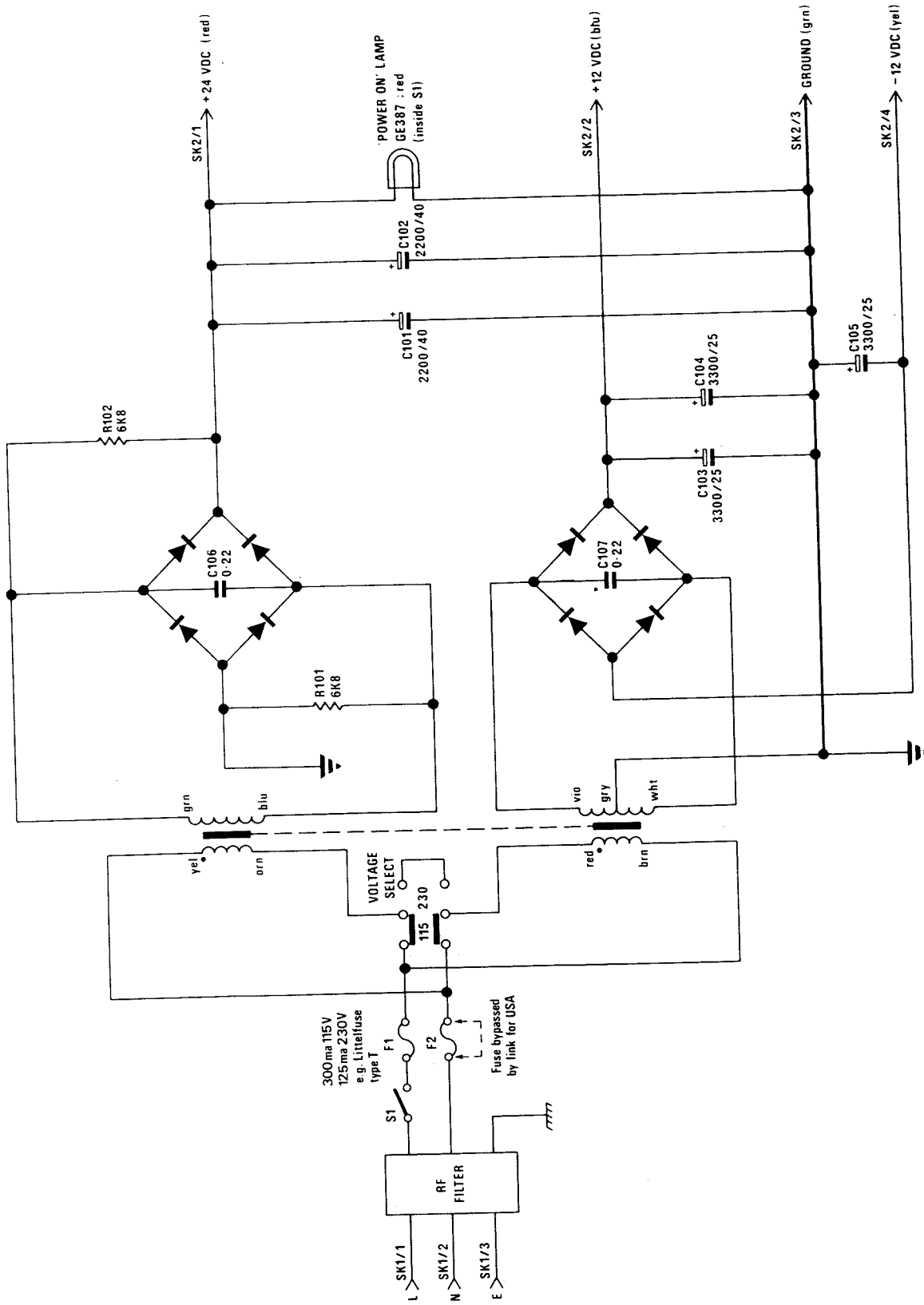

POWER SUPPLY MODULE
 © Dolby Laboratories Inc. 1977 Dwg. No. A2C1693

9.14 Power Supply Module, Cat. No. 114

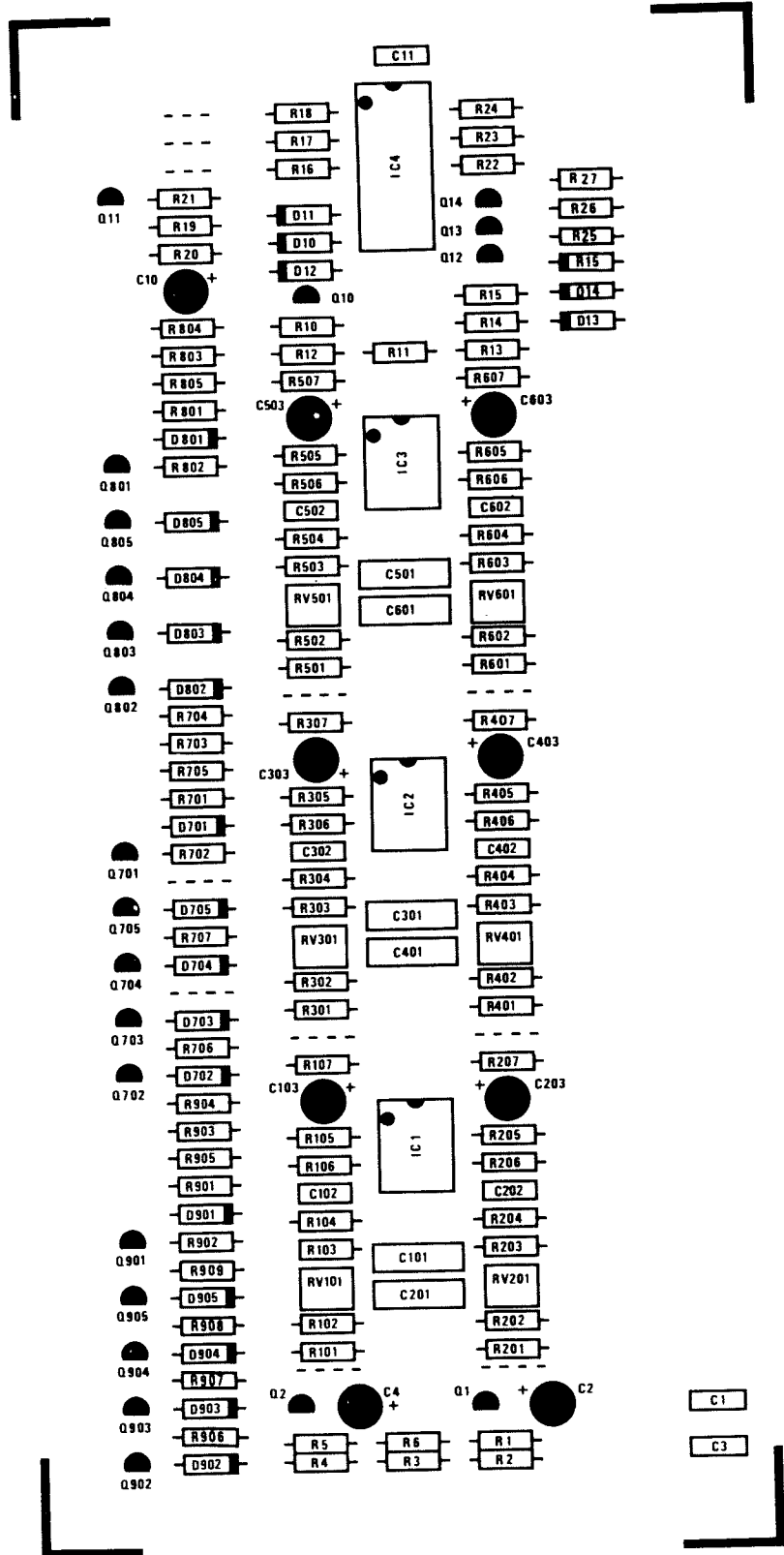

Q11

C10

Q801

Q805

Q804

Q803

Q802

Q701

Q705

Q704

Q703

Q702

Q901

Q905

Q908

Q904

Q903

Q902

R18

R17

R16

D11

D10

D12

R10

R12

R507

R505

R506

C502

R504

R503

RV501

R502

R501

R307

R305

R306

C302

R304

R303

RV301

R302

R301

R107

R105

R106

C102

R104

R103

RV101

R102

R101

R5

R4

C11

IC4

IC3

IC2

IC1

C4

R24

R23

R22

Q14

Q13

Q12

R15

R14

R13

R607

R605

R606

C602

R604

R603

RV601

R602

R601

R407

R405

R406

C402

R404

R403

RV401

R402

R401

R207

R205

R206

C202

R204

R203

RV201

R202

R201

R1

R2

R3

R6

R3

R27

R26

R25

R16

Q14

Q13

Q12

R15

R14

R13

R607

R605

R606

C602

R604

R603

RV601

R602

R601

R407

R405

R406

C402

R404

R403

RV401

R402

R401

R207

R205

R206

C202

R204

R203

RV201

R202

R201

R1

R2

R3

R6

R3

C1

C3

C2

C1

C3

C2

C1

C3

C2

C1

C3

C2

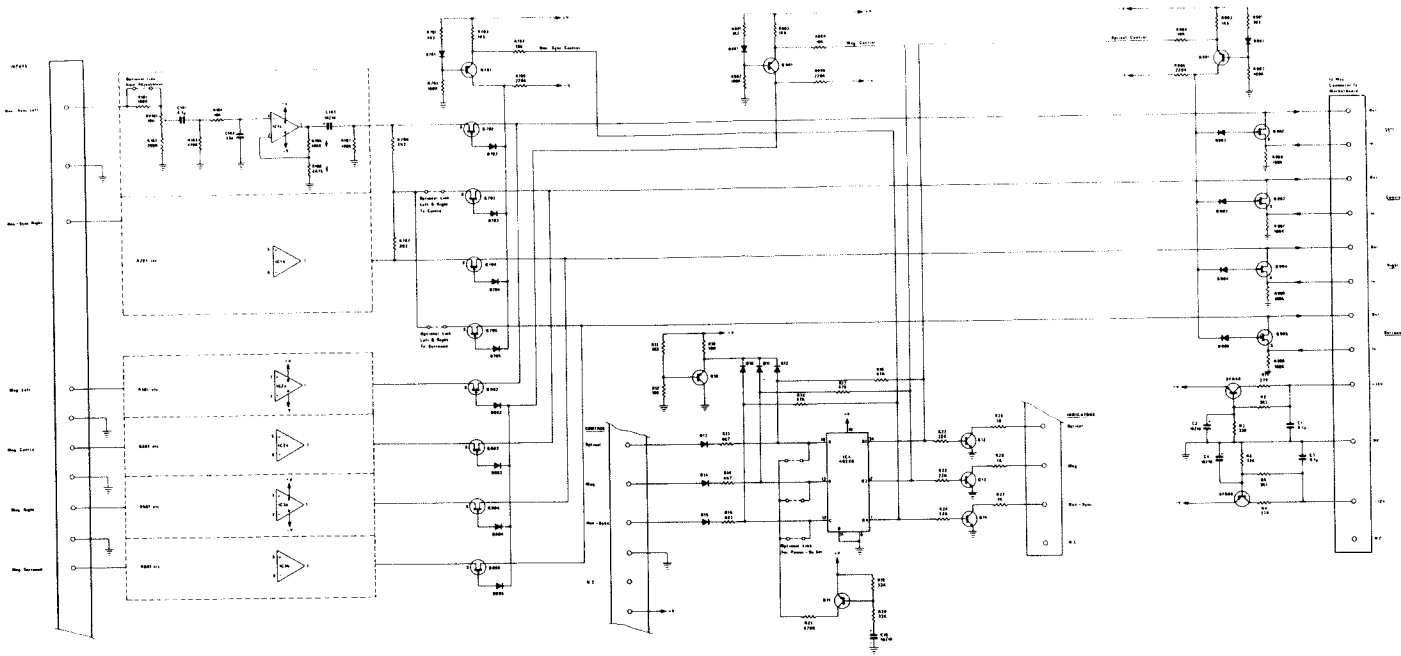

NOTES

- 1. QPN transistors are BC416 or equivalent unless marked otherwise.
- 2. PNP transistors are BC410 or equivalent unless marked otherwise.
- 3. F.E.T.'s are 2N5460 or equivalent.
- 4. IC1, 2, 3 are 74072.
- 5. Diodes are 1N4148.
- 6. All resistors are 25% except R which are 1%.

ADDS 5942
Issue 2

CP66 MAC & NON-SYNC BOARD
© 1966, International Business Machines Corporation

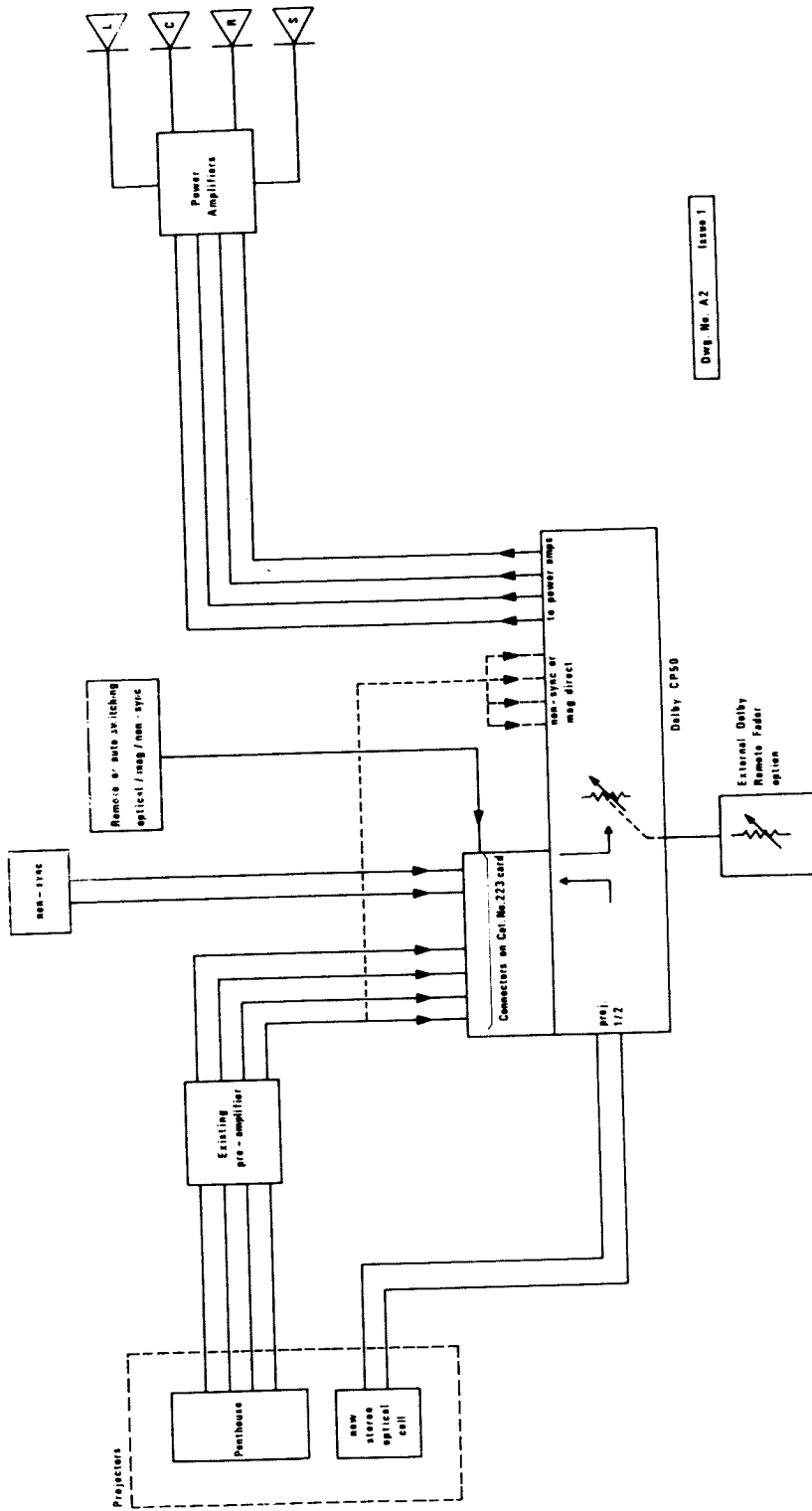

Doc. No. A2 Issue 1

Connection of non-sync and mag sources to CPS50 with remote changer using Cat. No. 223 option

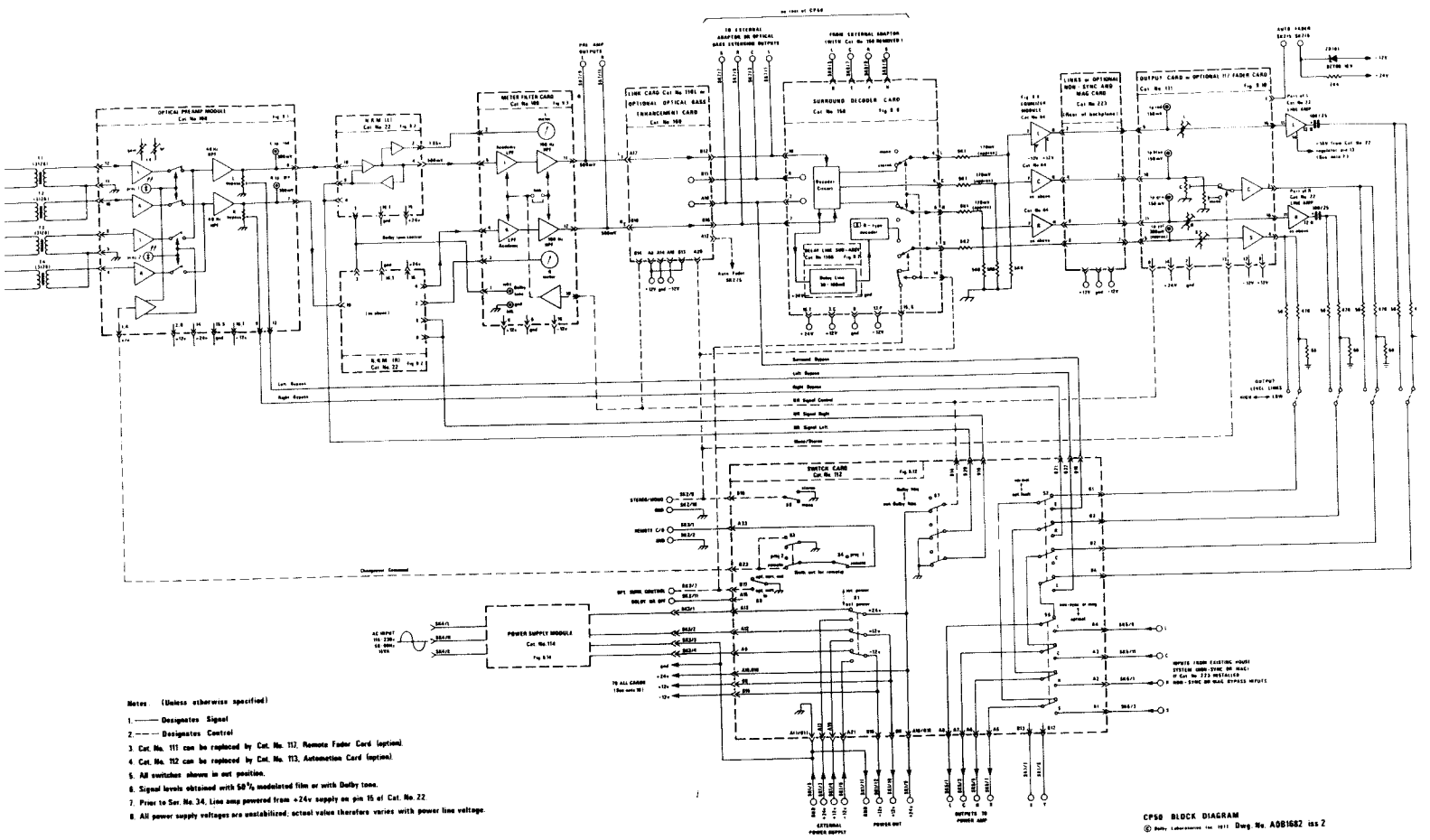

10.1

SECTION 10

CAT. NO. 22 NOISE REDUCTION MODULE - CIRCUIT DESCRIPTION

NRM

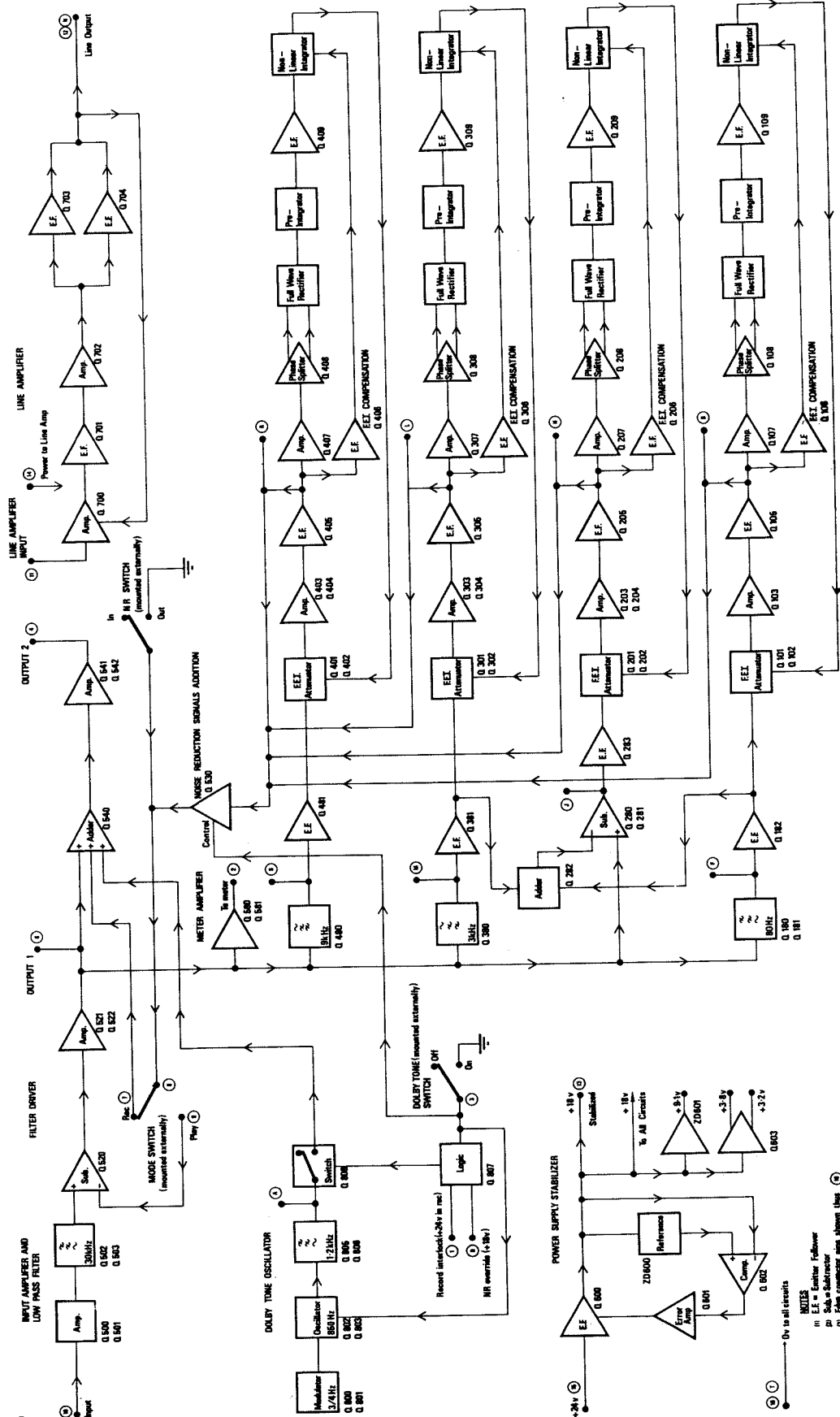

- NOTES
- (1) E.E. = Emittor Follower
 - (2) Sub = Subtractor
 - (3) Edge connector pins shown (top)
 - (4) Comp. = Comparator

10.1 Introduction

The block diagram on the opposite page outlines the electronic sections of the noise reduction module. The main signal path is shown along the top, from the Input Amplifier through Filter Driver, Output 2 Amplifier, and finally Line Amplifier sections. The side chain signals pass through the filters and compressors, are combined, and then combined additively or subtractively with the main signal.

Each section will be described in turn, and will be preceded in the text by its circuit diagram. In these, the convention is adopted of main signal paths being shown by a heavy solid line, feedback paths by a light outlining of the signal line, and noise reduction signal paths by a solid dotted line. The complete circuit diagram is given at the end of the Cat. 22 section of this manual.

10.2 Power Supply

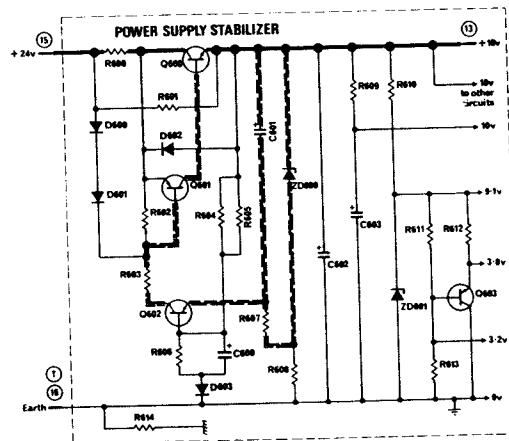

The Power Supply Stabilizer receives a roughly smoothed dc voltage (+24 V nominal, but with a minimum value of +19.5 V, including negative ripple excursions) and stabilizes this to 18.0 V \pm 0.3 V. The current supplied by the stabilizer is 105 mA, with a further 10 mA for the Line Amplifier. At high output levels, the Line Amplifier requirements reach a peak of 100 mA.

Transistor Q602 functions as a comparator, responding to the voltage difference between base and emitter. The zener action of ZD600 ensures that the emitter is always a constant 6.8 V below the output voltage; the base is held at a slightly higher voltage by the divider R605 and R606.

The operation of the circuit is best explained by considering the results of a change in output. If more current is demanded, the output voltage will tend to fall. Transistor Q602 emitter falls by the full amount of the change (since the voltage across ZD600 is always constant), but the base is held at a constant voltage by C600 for rapid changes;

for slower changes the base falls to a lesser degree owing to the potential divider action of R605 and R606. Transistor Q602 thus passes more current, and the resulting fall in collector voltage is amplified and inverted by Q601. The output voltage rises, counteracting the initial output voltage drop; the reverse action occurs if the output voltage rises. The series regulator transistor Q600 is bolted to a small heatsink which dissipates about 850 mW with a rough supply of 24 V.

In addition to voltage stabilization, the circuit also provides for foldback current limiting. If an increased current is demanded from the stabilizer, the voltage drop across R600 increases; Q601 then passes more current. When the voltage drop across R600 is greater than 0.7 V, diodes D600 and D601 conduct and clamp the base potential of Q601. Thus no more current will flow, and the output is current-limited. If the load is increased, the constant current mode progressively collapses into a foldback characteristic. Under short circuit conditions, the current flowing is typically 15 mA.

The module also produces a secondary supply of 10 V, a zener diode 9.1 V supply, and two voltages (3.2 V and 3.8 V) that are related by the base-emitter voltage of Q603. The difference in these two is therefore temperature-related, and this thermal dependence is used to compensate for variations which occur in the limiter circuits.

It is also possible to operate the processor module from batteries or other external supplies. A ripple-free voltage of about +18 V can be applied to pin 13; all parts of the circuit which are significantly voltage-sensitive are supplied from the 9.1 V supply, which is fully stabilized by the action of zener diode ZD 601. Diode D602 prevents transistor Q600 from becoming reverse-biased. The module operates correctly at lower supply voltages down to about +16 V, but with reduced output capability. The current requirement is dependent on the supply voltage used, 115 mA being drawn at +18 V. The maximum voltage which can be applied to pin 13 is 28 V; higher external voltages or supplies with ripple present should be applied to pin 15 with series resistors if necessary to limit the voltage at pin 15 to 30 V.

10.3 Input Amplifiers

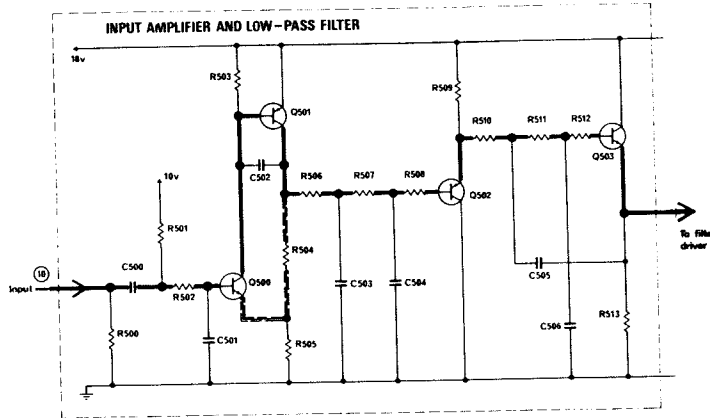

Input signals are applied to the input stage via an RF filter (R502 and C501). Transistors Q500 and Q501 function as a high input impedance unity-gain amplifier. The maximum sensitivity of the module is 300 mV for Dolby Level (corresponding to a magnetic tape flux level of 185 nWb/m, Ampex Operating Level). Transistors Q502 and Q503 form a two-stage active 34 kHz low pass filter, which prevents tape recorder bias or high frequency interference from entering the module and affecting the noise reduction circuitry.

10.4 Filter Driver

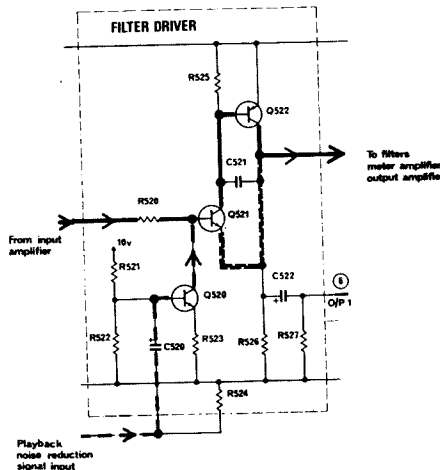

Transistors Q521 and Q522 act as a high input impedance, low output impedance unity-gain amplifier, which is designed to feed the filter amplifiers. The noise reduction signal (which will be described in detail in Sections 10.9, 10.10, and 10.11) is routed in the playback mode to Q520, via pin 9. At pin 9 it is in phase with the signal at Q503 emitter; the inverting action of Q520 causes the noise reduction signal voltage developed across R520 to subtract from the main signal path voltages. A reduction in gain at low playback signals is thus achieved (see Section 4).

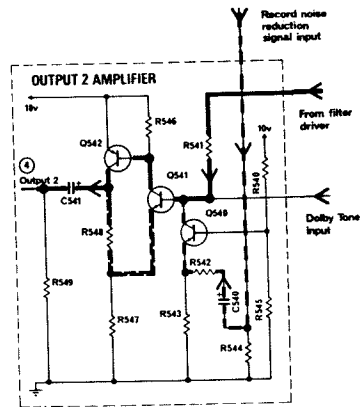
10.5 Output 2 Amplifier

The main path continues to Output 2 Amplifier; Q541 and Q542 are arranged in a feedback amplifier configuration to raise the 300 mV signal to 500 mV. The output signal (pin 4) can be used independently; for example, in situations where the module is an integral part of a tape recorder, this signal would go via a preset calibration control to the record amplifier input.

In the case of the Model 360, 361 and 364 Noise Reduction Units it passes via a potentiometer (Output Level) to the input of the Line Amplifier.

The noise reduction signal is applied in the record mode to Q540 emitter; being in phase with the signal at Q522 collector, the noise reduction signal adds to the main signal in R541 to provide the desired record characteristics (see Section 4).

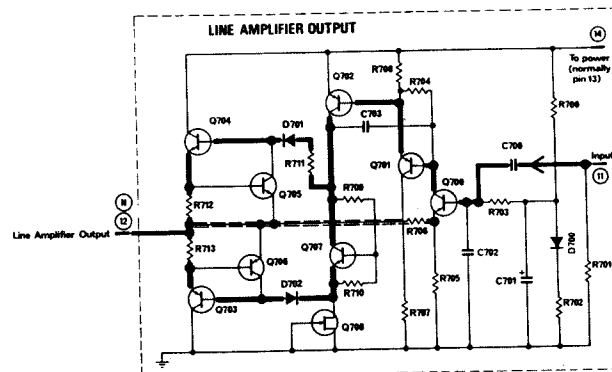
10.6 Line Amplifier

The module contains an independent line amplifier, with an input on pin 11 and an output on pins 12 and N. The amplifier can be fed from any signal — for example from Output 1 or Output 2 via appropriate attenuators. The amplifier is designed

to feed a 1:2 transformer to provide balanced or floating outputs. The normal input level is 90 mV for a 600 mV output (e. g. 1.23 V, +4 dBm with the transformer). Via the transformer, the clipping level is +16 dB (relative to 0 dB = 0.775 V) into 200 ohms or +21 dBm into 600 ohms when powered from the internal 18 V supply (pin 14 strapped to pin 13). Higher outputs, at slightly higher hum levels, can be obtained by connecting the positive voltage rail (pin 14) directly to the +24 V rough supply (pin 15). Still higher output levels can be obtained by using an external higher voltage connected directly to pin 14. This external voltage should not exceed 40 V, and should have a maximum ripple content of less than 1 V peak to peak.

Transistors Q700 and Q702 form a voltage amplifier, with Q701 isolating the two gain stages. Transistors Q703 and Q704 are complementary-symmetry emitter followers, whose quiescent current is determined by the amplified diode arrangement Q707, R709, and R710. Negative feedback is taken from the output to the emitter of Q700 via R706 to determine the gain and raise the input impedance. Transistors Q705 and Q706 act as current limiters; if, for example, high positive-going currents are demanded from the output stage, the voltage across R712 must rise and hence the base voltage of Q705 rises. Eventually Q705 conducts and limits the base voltage on Q704, thereby limiting the output current. Similarly on opposite half cycles, transistor Q707 operates. Thermal protection is provided by mounting transistors Q707 and Q704 in a single copper clip; any rise in the output stage temperature is transferred to transistor Q707, reducing the collector-emitter voltage and hence reducing the output stage current. Thermal runaway is thus prevented.

10.7 Meter Amplifier

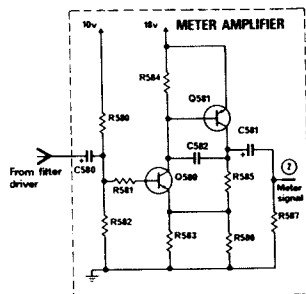

The meter amplifier comprises transistors Q580 and Q581, which function as an amplifier with low output impedance for driving a suitable meter incorporating rectifier diodes. The amplifier is driven from the filter driver output (Output 1), which is called the reference point. All compressor characteristics are related in a fixed manner to the voltage at this point. Level calibration of the unit is thus achieved when the input voltage (from the tape recorder, for example) is adjusted to read the correct level at this point. A reference level, called Dolby Level, can be related to the operating standards of the medium with which the noise reduction system is used. In professional tape recording, Dolby Level corresponds to a tape flux of 185 nWb/m (Ampex Operating Level), which should be replayed to give 300 mV at the reference point; the meter amplifier then produces 1.85 V at pin 2. Similarly, if a reference tape flux of 320 nWb/m is the standard in use (European practice), the meter amplifier produces 3.2 V at pin 2. The amplifier gain is precisely set during manufacture by selection of R583. Pin 2 can be connected to any suitable meter via an appropriate attenuator.

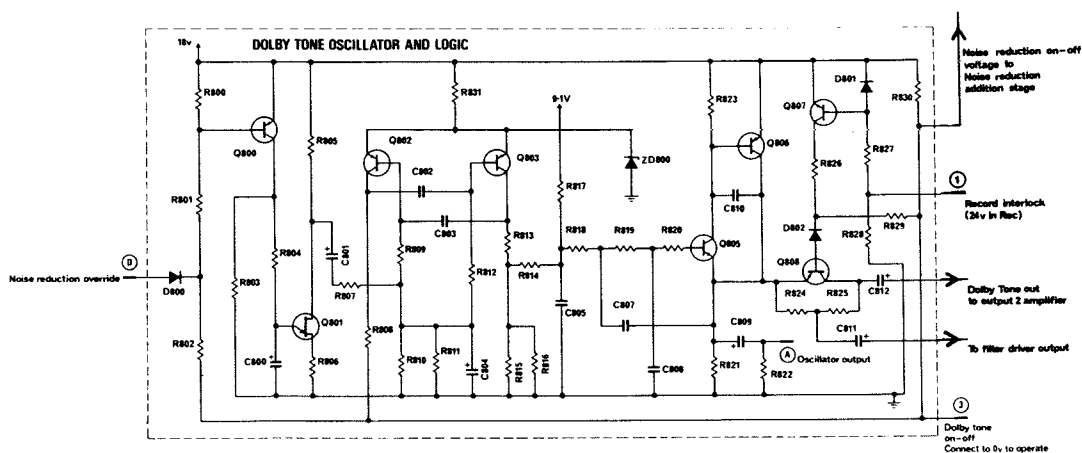
10.8 Dolby Tone Oscillator

To assist in recorder gain calibration and level setting, each module includes a built-in oscillator. The output of the oscillator is injected into the signal circuit at a level corresponding to Dolby Level.

Transistors Q802 and Q803 form a 850 Hz multivibrator, which oscillates when pin 3 is earthed (by operation of an external push-to-make Dolby Tone switch). In multichannel installations, the Dolby Tone on-off line (pin 3) of all channels may be commoned, so that a single switch operates all modules. The square wave output from the oscillator passes to a three-stage active filter. The output from Q805 and Q806 is a sine wave of approximately 2% total harmonic distortion. For use with the NRM Tester (Cat. No. 35) this output is available on pin A.

Transistor Q808 is an electronic switch; in one condition it presents a high impedance, in the other a low impedance. With the switch in the low impedance mode, the oscillator output is routed to the input of the Output 2 amplifier. Since the output impedance of Q805 and Q806 is low, any signals from the filter driver will be almost completely attenuated by the action of R541 (10 k) working into this low impedance. However, any such signals will nevertheless register on any meter connected to the meter amplifier. This facility can be used during record gain calibration, when pressing the Dolby Tone switch can be arranged to feed Dolby Tone to the record amplifier in a tape recorder, while leaving the input amplifier of the noise reduction module connected to the playback side. The meter will then read the Dolby Tone signal actually played back from the tape, allowing the record level controls on the recorder to be set precisely.

The electronic switch itself is programmed to operate only in the record mode of the tape recorder. Under record mode conditions, a +24 V record interlock signal is applied to pin 1, turning transistor Q807 off. If pin 3 is earthed, the

base of Q808 is made more negative than the emitter, which is held at about +3.5 volts by Q805 and Q806. Transistor Q808 therefore conducts. If pin 3 is not earthed, the voltage rises to about +15 volts, which turns Q808 off.

If the 24 volt record interlock signal is not present on pin 1, then Q807 will conduct. The base of Q808 is thus held more positive than the emitter, which prevents the electronic switch from conducting, whether or not pin 3 is earthed. Note that earthing pin 3 will still turn the oscillator on, providing an output at pin A for use with the NRM Tester. However, under these conditions the output will not be injected into the signal circuitry via Q808.

To equalize the dc voltage component across the transistor switch Q808, a resistor must be added from emitter to collector; if the switch is to have a high on-off resistance ratio, the value of this resistor must be large. To avoid the use of high value resistors, two resistors of comparatively low value (R824 and R825) are used with their centre point bootstrapped via C811 to a low impedance point carrying the same signal as is present on Q808 collector.

The Dolby Tone on-off line (pin 3) is also connected to the noise reduction signals addition stage, described in Section 10.11. When pin 3 is earthed, the noise reduction action is electronically removed. Note that this action occurs in both the record and playback modes. Since the on-off line may be paralleled for simultaneous operation of all channels in a multichannel installation, this allows a single switch both to turn on all oscillators for record calibration and to remove the noise reduction action during playback calibration.

To make the Dolby Tone distinctive, it is frequency-modulated. Transistor Q801 is a unijunction device, functioning as a relaxation oscillator. When pin 3 is earthed, a current is fed from Q800 into C800, which slowly charges up towards +18 V. When the peak point emitter voltage of the unijunction is reached, the base emitter junction becomes low impedance, discharging C800. The interbase resistance is low, and the resulting current flow produces a negative-going pulse in R805. Transistor Q801 then reverts to its off state, and C800 recommences its charging cycle. The time constants are arranged to produce a 30 msec pulse with a period of 750 msec. The pulse is applied to the multivibrator timing resistors R809 and R812, raising the frequency by approximately 10% for the pulse duration.

To avoid confusion when the oscillator is used with the NRM Tester, the frequency modulation is removed. In these circumstances pin D is taken to a voltage of +18 V or higher, so that Q800 becomes non-conducting. Capacitor C800 cannot charge, and hence Q801 will not oscillate.

10.9 Filters

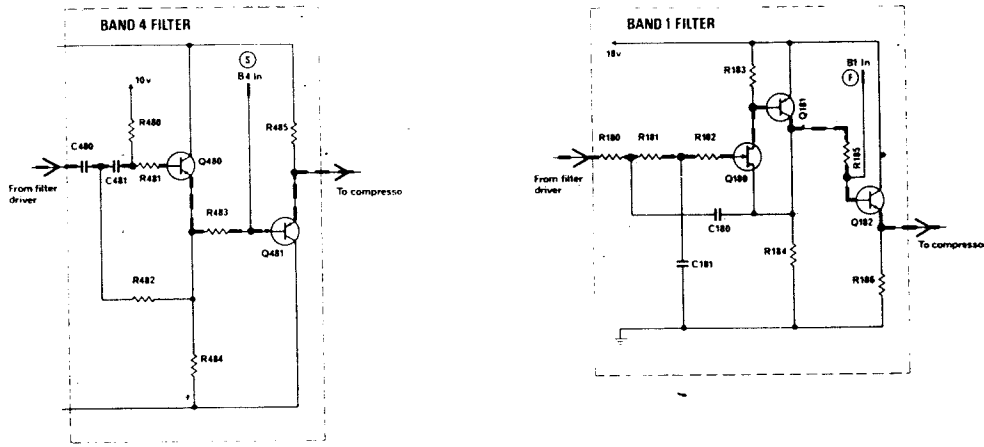

The side chain or differential path commences at the output of the filter driver Q521 and Q522. This stage drives the four filters, which split the audio signal into four frequency bands. The output from each of these bands passes through an independent low-level compressor before being combined to form the noise reduction signal which is then re-introduced to the main signal path. Bands 3 and 4 are both high-pass filters of identical circuit configuration with changed component values; only Band 4 is shown above.

Transistor Q480 is an active high pass filter, with the components C480 and C481, together with R480 and R482, chosen for a cutoff frequency of 9 kHz. Transistor Q581 is an emitter follower. Similarly, Q380 forms a 3 kHz high-pass filter. A rearrangement of capacitors and resistors in a similar circuit around Q180 forms an 80 Hz low-pass filter. In this filter a field effect transistor is used to raise the input impedance (allowing small value capacitors to be used) and the transistor amplifier Q181 is used to provide a low output impedance.

The band 2 filter provides for a band-pass characteristic from 80 Hz. to 3 kHz, with an amplitude and phase response which is complementary to that of bands 1 and 3. This is achieved by subtracting the outputs from band 1 (80 Hz, low pass) and band 3 (3 kHz, high pass) from the wideband input signal.

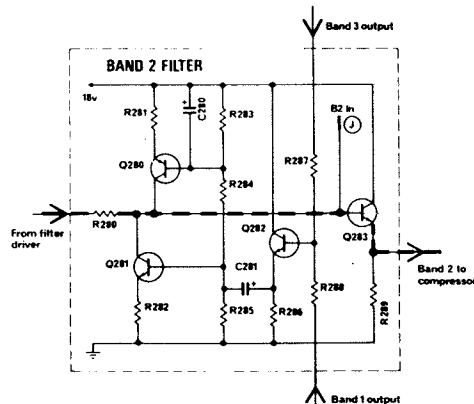

The outputs of bands 1 and 3 are added at the base of Q282 by R287 and R288, and then inverted by Q281. The collector current is thus proportional to the outputs of bands 1 and 3, but is out of phase. This difference signal is combined with the wide-band signal by R280, providing the required signal in the band 80 Hz to 3 kHz, and passes to the Band 2 compressor via emitter follower Q283.

To avoid a dc voltage drop in R280 which would reduce the dynamic range of stage Q281, Q280 provides a constant dc current which is equal to the average current of Q281; hence, no significant dc current flows in R280.

10.10 The Compressors

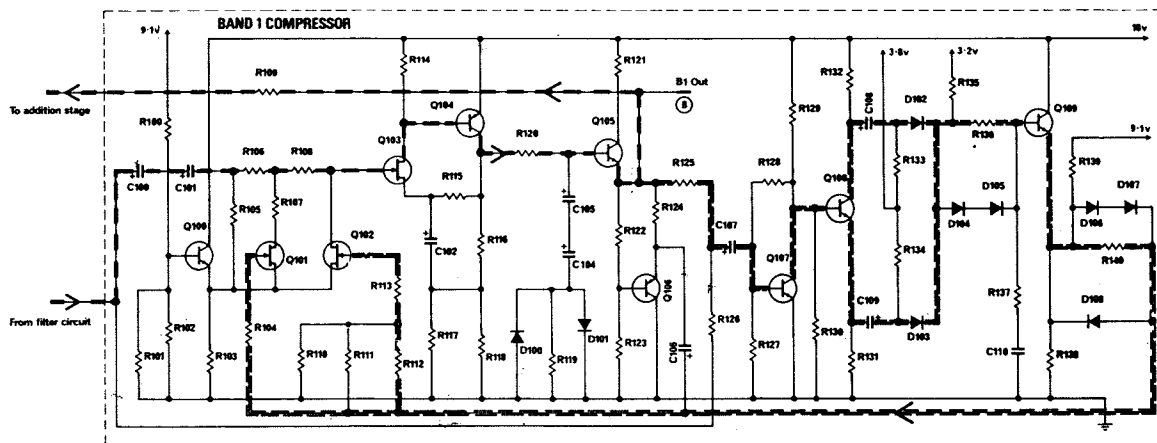

The compressors in all four bands are substantially identical, and thus only that of band 1 need be described. The signal from each filter enters the compressor and under low level signal conditions is passed unattenuated to Q103 and Q104, an amplifier with a very high input impedance produced by the field effect transistor Q103. Transistor Q105 is an emitter follower; the output is taken via R109 to the noise reduction signals addition stage. The overall signal gain of the compressor is precisely set during manufacture by selecting R117.

The control signal amplifier comprises the amplifier Q107 and phase splitter Q108. The audio signal is rectified by D102 and D103, and the resulting dc is smoothed in the pre-integrator R136 and R137 together with C110. The pre-integrator output passes via Q109 to the final integrator R140 and C106. The time constants of the integrators in bands 1 and 2 are twice those in the higher frequency bands.

Both pre- and final integrators have non-linear characteristics produced by the diodes D104-D108. Fast, large changes in signal amplitude are passed quickly, whereas small changes are transferred slowly. This dynamic smoothing action produces optimum results with respect to modulation effects, low frequency distortion, and distortion components generated by the control signal. The circuit achieves both fast recovery and low signal distortion; in conventional arrangements these two criteria are mutually exclusive.

The resulting dc control signal is fed to the gates of the field effect transistors Q101 and Q102, which act as variable resistances in two series L-attenuators. The control voltage applied to Q102 is a dc offset and slightly attenuated version of that to Q101. Both FETs are factory-selected for similar pinch-off voltages, so that as the control voltage rises, first Q101 and then Q102 conducts. The attenuation produced by Q101 is limited by R107 working against R106 and the source-drain resistance of Q101. Therefore the rate of change of attenuation is gentle. As the signal level increases, the rising control voltage causes Q102 to conduct, and the rate of attenuation increases. The source voltage is factory-adjusted by R101 and R102 to compensate for differing pinch-off voltages of the FET pair. Similarly, R111 and R112 are adjusted to match the required precise compressor curve. R105 maintains dc conditions across the FET pair.

At high signal level inputs, it is desirable to reduce the compressor output still further, so that the noise reduction signal represents a negligible proportion of the main signal. To achieve this, some of the input signal to the compressor is fed forward around the attenuator section through R126. Under low-level signal conditions, when Q101 and Q102 produce no attenuation, the output from the amplifier (passing through R125) is considerably greater than the feed-forward signal. As the attenuator operates, the proportion of feed-forward to normal signal entering the control signal path increases, until eventually primary control is produced by the feed-forward component. This in turn produces the down-turning curve of the compressor input-output characteristic.

FET compressors produce even-order distortion components unless correction techniques are used. While this distortion can be reduced by operating the FET in a push-pull configuration, it can be shown that this is equivalent to adding half the ac drain signal to the gate terminal. In the Cat. No. 22 compressor circuit this is achieved by taking the correct proportion of the FET output signal and adding this in series with the dc gate control voltage. Transistor Q106 adds this signal, at the same time providing the low impedance necessary for smoothing the dc control signal by C106. Resistors R122 and R123 form an attenuator to compensate for the gain of Q103 and Q104, reducing the ac signal on the emitter of Q106 to half that on the base of Q103.

Diodes D100 and D101 form a non-linear limiter circuit to prevent transient overshoots of the noise reduction signal during the compressor attack period. Under normal signal conditions the diodes are non-conducting, but under extreme transient conditions the diodes limit the noise reduction signal to a level which results in an overall output overshoot of less than 2 dB. The limited overshoot condition applies for about 1 msec only and is inaudible; when added to the high-level main signal, the noise reduction signal represents a very small proportion of the total signal. Two series capacitors C105 and C104 are used to prevent leakage currents forward-biasing the diodes.

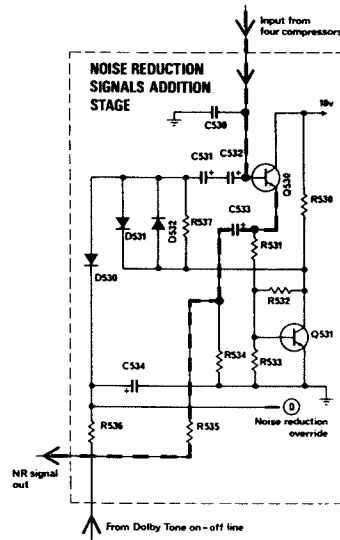
10.11 Noise Reduction Signals Addition Stage

The outputs from the four compressors are fed to the addition stage via mixing resistors R109, R209, R309, and R409. Transistor Q530 is an emitter follower providing a low output impedance noise reduction signal.

If the limiting diodes D100 and D101 are operative in two or more bands, the transient signals from the compressors will combine additively. Under these conditions diodes D531 and D532 conduct, reducing the amplitude of the combined transient without any further limiting of the noise reduction signal itself. Amplifier Q531 provides an out-of-phase signal to the lower end of the diodes, to provide correct threshold conditions for the diodes and the signal levels present at this point.

The noise reduction signal appears on pin 8 and is connected to the record mode input (pin 7) or playback mode input (pin 9) by a suitable external single pole changeover switch. By earthing pin 7 the noise reduction signal is cancelled; the module then becomes a linear amplifier.

The noise reduction action is also removed by operation of the Dolby Tone oscillator. Under normal conditions D530 is reverse-biased by the positive voltage difference between the collector of Q531 (+6 V) and the Dolby Tone on-off line (+15 V on pin 3, to which D530 is connected via R536). However, when the Dolby Tone oscillator is operated by earthing pin 3, D530 conducts and short-circuits the noise reduction signal. This facility is useful during the playback calibration procedure, especially in multichannel installations where the Dolby Tone on-off lines may be connected together.

Certain modes of the NRM Tester require that the oscillator should work and also that the noise reduction signal should be available. The NRM Tester therefore feeds +18 V into pin D in these modes, so that D530 is maintained in the non-conducting state even when pin 3 is earthed.

10.12 General Notes

To facilitate incorporation of the NRM into tape recorders and mixers, all inputs and outputs are in phase. Furthermore, all outputs are at low impedance and are thus tolerant of the effects of wiring lengths. Cables of up to 30 m (100 feet) may be attached to any of the module outputs.

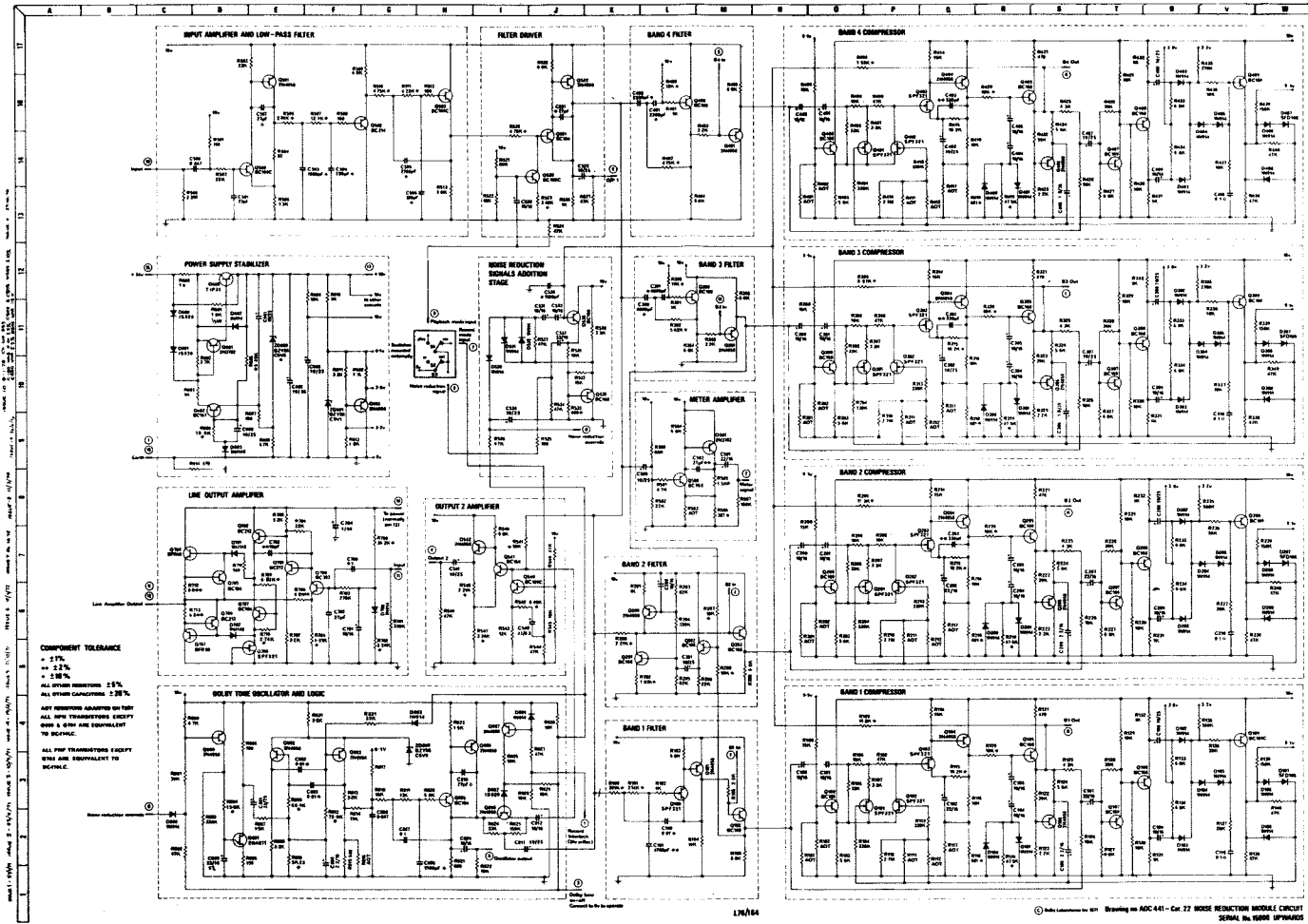

COMPONENT TOLERANCE
 ± 1%,
 ± 2%,
 ± 5%,
 ± 10%
 ALL OTHER RESISTORS 15%
 ALL OTHER CAPACITORS 10%
 ANY RESISTOR ADJUSTED ON TEST
 ALL PNP TRANSISTORS EXCEPT
 2N4104 & 2N4105 ARE EQUIVALENT
 TO BC107.
 ALL PNP TRANSISTORS EXCEPT
 2N4104 & 2N4105 ARE EQUIVALENT
 TO BC107.

LN7454

© 1974 International Telephone and Telegraph Corporation. Drawing No. AOC-441 - Cir. 12 NOISE REDUCTION MOBILE CIRCUIT SERIAL No. 1000 UPWARDS

12.1

SECTION 12

SERVICING

CAT. NO. 22 NOISE REDUCTION MODULE

12.1 Introduction

Module exchange is the easiest and most reliable method of repair of the Cat. No. 22 Noise Reduction Module (NRM). However, for situations in which this is not practical, this section provides some basic guidance in user-servicing.

The NRM has been designed for accuracy, reliability, and long life. The individual circuits operate well below their dissipation limits, and close tolerance high stability components ensure repeatability and accuracy of system parameters. There is no need for adjustment of the printed circuit card; the critical parts of the circuit are pre-adjusted during manufacture with fixed-value selected components, using custom-designed test equipment and procedures.

Routine maintenance is confined to verification of the system performance. Repair is usually and most practically achieved by module interchange; faulty modules are then exchanged by local distributors or Dolby Laboratories offices. All modules are guaranteed by Dolby Laboratories for a period of one year from receipt by the customer, the guarantee including freight charges. Subject to the particular customs formalities of the customer's country, the repair will usually be effected on a replacement-basis, with a new or factory-tested module, ensuring that studio inconvenience is kept to a minimum.

12.2 Cat. 35 NRM Test Set

The Cat. No. 35 Test Set (Section 13) is designed for the rapid testing and verification of NRM performance. Needing no external test equipment, the Test Set checks all major functions of the NRM in less than a minute using an internal GO/NO GO meter. More sophisticated tests can also be carried out by the use of external test sources and measuring requirement. Terminals are provided which allow the use of an oscilloscope and ac and dc meters to check points monitored by the tester. This feature allows the circuit area of many faults to be identified quickly. While most troubleshooting and repair work can be achieved by the use of the internal oscillator of the Cat. No. 22, the Test Set also provides terminals and a switch for the use of an external oscillator when necessary.

12.3 Fault Repair

Faults can be categorized into three types. The first type is that of complete failure, which will usually involve a single component in a particular section of the circuit. Such faults are readily traceable, and in general repairs can be made by substitution of a new component.

The second type of fault is a partial, rather than complete, failure. While this may be more difficult to diagnose than the first type, the failure, as before, will usually concern only a single component.

The third and most difficult fault is the intermittent one. It may be difficult to provoke the fault on the test bench, but it will usually yield to one or more of the following factors: heat, cold, humidity, jolts, vibration, or time. Usually only a single component will be involved.

On modules above serial number 2400, an epoxy covering is provided on the top printed circuit tracks; this greatly diminishes the possibility of shorts between the tracks and resistors crossing the tracks. Therefore, even though the resistor bodies are themselves well insulated, the probability of top track shorts is greater on the non-covered boards prior to serial number 2400. This fact should be borne in mind during troubleshooting.

DC voltages are perhaps the best clue to malfunctions, and at the end of this section there is a table showing the principle voltages in the module. The circuit diagram (rear of Section 10) indicates the component tolerances which must be used in all cases of component replacement.

Any fault which involves replacing a selected component, such as the adjust-on-test (AOT) resistors, a component in the +9 volt regulator, or any of the compressor field effect transistors, is not repairable by the user. These components are in general those which determine the Dolby A-type noise reduction characteristic, and are set up to a high degree of accuracy at the factory using specialized test techniques and apparatus. An attempted user repair may compromise the performance of the unit, and all such failures should be returned to Dolby Laboratories or one of its distributors for exchange.

12.4 NRM Test Set Voltage Measurements

It is possible to identify the defective circuit fairly readily by the use of the NRM Test Set even before the module covers are removed. The main ac characteristics can be checked by the use of the internal oscillator and meter, as well as by the test points on the rear of the NRM Tester. Similarly, a number of significant dc measurements can be made using the NRM test points.

For the tests, the Cat. No. 22 module should be plugged into the NRM Tester. The Test Extender should be plugged into the 360 Series or other unit supplying power, and the cable connector should be plugged into the NRM Tester. In the tests, the pin connections and ac and dc voltages brought out from the Cat. No. 22 module to the test point on the rear of the NRM Tester are given in parentheses.

1. In the 24 V position of S1, the ripple on the incoming rough dc supply is checked (pin 15, 600 mV ac maximum, 20-28 V dc).
2. In the 18 V position of S1, the ripple and noise on the output of the module voltage regulator are checked (pin 13, 400 uV ac maximum, 100 kHz bandwidth, 17.5 - 18.5 V dc).
3. In the OSC position of S1, the output of the module oscillator is checked (pin A, 290 - 310 mV ac, 0 V dc). In this position the signal from pin A is also amplified in the NRM Tester to 1.85 V ac, 0 V dc, at connector JF1 and is used to check the calibration of level setting meters (Dolby Level, 185 nWb/m). When the DIN CHECK button is pressed, the signal from pin A is amplified to 3.2 V at JF1 (corresponding to 320 nWb/m).
4. In the OUT 1 position of S1, the signal from the module oscillator (pin A) is fed into the module input (pin 10), and the main-path signal circuit is checked at Output 1 (pin 6, 290 - 310 mV ac, 0 V dc), which follows the playback noise reduction signal combination point.
5. In the METER AMP position of S1, the signal from the module oscillator (pin A) is fed into the module input (pin 10), and the output of the meter amplifier is checked (pin 2, 1.8 - 1.9 V ac, 0 V dc).
6. In the OUT 2 position of S1, the signal from the module oscillator (pin A) is fed into the module input (pin 10), and the main-path signal circuit is checked at Output 2 (pin 4, 480 - 520 mV ac, 0 V dc), which follows the record noise reduction signal combination point.
7. In the DOLBY TONE position of S1, the module oscillator is FM modulated to produce the Dolby Tone, the electronic switch Q808 is energized, and the signal at Output 2 is checked (pin 4, 480 - 520 mV ac, 0 V dc).
8. In the LINE AMP position of S1, the signal from the module oscillator (pin A) is fed into the line amplifier input (pin 11) and the output of the line amplifier is checked (pins 12, N; 1.9 - 2.1 V ac, 8 - 10 V dc).
9. For the compressor tests, switch S1 is set at COMPRESSORS. In this position, the signal from the module oscillator (pin A) is attenuated to 2 mV, 10 mV, and 50 mV for the GAIN, LAW 1, and LAW 2 tests, respectively (S2). The attenuated signal is fed into the input of the compressor selected by S2 (pins, F, J, M, and S for bands 1 - 4, respectively). The outputs of the compressors are checked as follows (pins B, H, L, and R for bands 1 - 4, respectively):

12.5

- A. GAIN, 16 - 18 mV ac, 6 - 8 V dc.
 - B. LAW 1, 55 - 65 mV ac, 6 - 8 V dc.
 - C. LAW 2, 67 - 77 mV ac, 6 - 8 V dc.
10. In the RECORD position of S1, the module is connected in the record mode (pin 8 connected to pin 7), and a signal from the module oscillator (pin A) is attenuated to 3 mV and fed into the module input (pin 10). The output of the module is checked at Output 2 (pin 4, 15 - 17 mV ac, 0 V dc).
 11. In the NR OUT position of S1, the noise reduction signal is disabled and a signal from the module oscillator (pin A) is attenuated to 3 mV and fed into the module input (pin 10). The output of the module is checked at Output 2 (pin 4, 4.8 - 5.2 mV, 0 V dc: i. e. 9.5 - 10.5 dB lower than in test 10 above).
 12. In the PLAY position of S1, the module is connected in the playback mode (pin 8 connected to pin 9) and a signal from the module oscillator (pin A) is attenuated to 3 mV and fed into the module input (pin 10). The output of the module is checked at Output 2 (pin 4, 1.5 - 1.7 mV ac, 0 V dc; i. e. 9.5 - 10.5 dB lower than in test 11 above).

12.5 Comprehensive dc Voltage Measurements

Once the general circuit area of the fault if given by the tests in Section 12.4 above, the module covers should be removed for further investigations.

Detailed circuit tests can be made of the suspected area by referring to the voltage tables given on pages 12.7 to 12.9, the test point location drawing on page 12.6, and the component location drawing on page 12.10.

The NRM Tester can be used on its side for this application, allowing access to both top and bottom of the NRM.

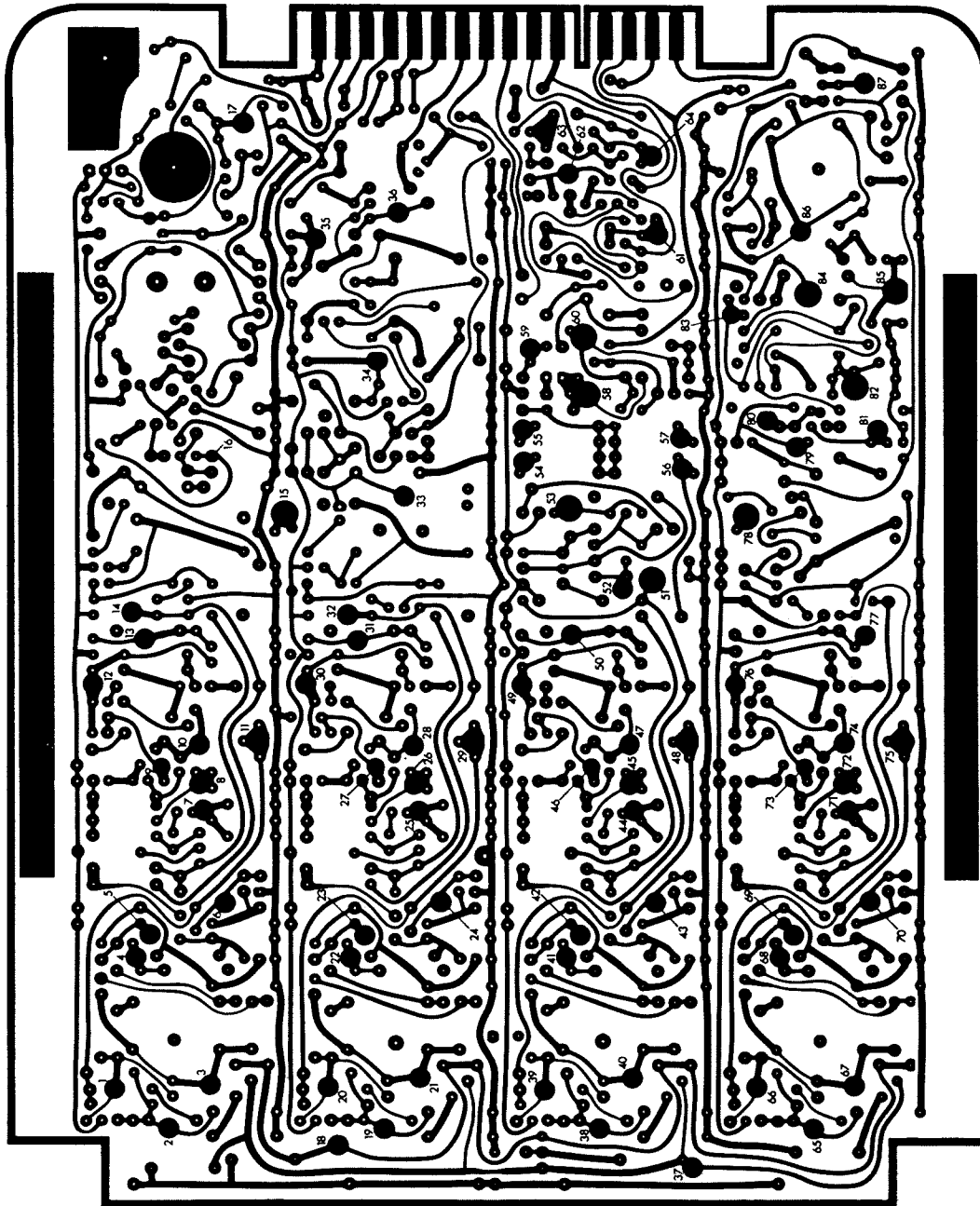

Test Points

1-17

18-36

37-64

65-87

CAT No. 22 TEST POINT LOCATIONS

Drg. No. AIPM 747

© Dolby Laboratories Inc. 1972

Voltage Tables

1. Power Supply Voltages

- Note: 1. Pin number are circled.
2. dc voltage tolerance ± 0.5 V except where stated.

Measuring point	Testpad/Pin No.	dc voltage	max ac (rms)
Incoming rough supply	⑮	24 (± 4)	600 mV
+18 v line	⑬	18	400 uV
+10 v line	15	10.2	-
+9.1 v line	84	9.1	-
+3.2 v line	37	3.2	-
+3.8 v line	18	3.8	-

2. Main signal path

Note: Collector designated c, emitter designated e.

Measuring point	Testpad/Pin No.	dc voltage	ac voltage with Cat. No. 35
Q503 e	34	9.6	Out 1 290-310 mV
Q522 c	33	8.1	Out 1 290-310 mV
Q542	62	10.0	Out 1 480-520 mV
Q581 c	63	10.5	Out 1 1.8-1.9 v
Q700 e	16	1.4	Line Amp 290-310 mV
Line Amp Output	⑫ or ⑮	9.0	Line Amp 1.9-2.1 v

3. Noise Reduction Path

Measuring point	Testpad/Pin No.	dc voltage	ac voltage with Cat. No. 35
Q182 e	78	10.5	
Q283 e	51	6.8	
Q282 e	52	10.0	
Q381 e	32	10.2	
Q481 e	14	10.2	
Q100 e	76	5.9 (1)	
Q200 e	49	5.9 (1)	
Q300 e	30	5.9 (1)	
Q400 e	12	5.9 (1)	
Q105 e	ⓑ	6.8	} Gain 16-18 mV Law 1 55-65 mV Law 2 67-77 mV
Q205 e	ⓓ	6.8	
Q305 e	ⓔ	6.8	
Q405 e	ⓕ	6.8	
Q108 c	69	14.3	
Q208 c	42	14.3	
Q308 c	23	14.3	
Q408 c	5	14.3	
Q109 e	65	3.2 (2)	
Q209 e	38	3.2 (2)	
Q309 e	19	3.2 (2)	
Q409 e	2	3.2 (2)	
Q106 e	70	1.0	
Q206 e	43	1.0	
Q306 e	24	1.0	
Q406 e	6	1.0	
C106/R140 Gain	75	3.1	
Law 1	75	3.5	
Law 2	75	3.7	
C206/R240 Gain	48	3.1	
Law 1	48	3.5	
Law 2	48	3.7	
C305/R340 Gain	29	3.1	
Law 1	29	3.5	
Law 2	29	3.7	
C406/R440 Gain	11	3.1	
Law 1	11	3.5	
Law 2	11	3.7	
Q530 e	59	6.6	
Q531 c	60	3.0	

Note: (1) Prior to Serial No. 1500, tolerance is ± 2 v
(2) High input impedance voltmeter must be used

4. Oscillator and Logic

Measuring point	Testpad/Pin No.	dc voltage	Notes
Q803 e	83	6.8	
Q805 e	86	3.6	Normal operation in installation, or Cat. 35 'Noise' modes.
Q805 e	86	3.0	D. T. button pressed, or all Cat. 35 modes except 'Noise'.
D. T. line	③	13.5 ±2	Normal operation in installation.
D. T. line	③	0	D. T. button pressed, or all Cat. 35 modes except 'Noise'.
Q807 c	87	17.9	Installation Play mode or all Cat. 35 modes except 'Dolby Tone'.
Q807 c	87	1.7	Cat. 35 'Dolby Tone' mode. Installation Record Mode or Cat. 35 'Dolby Tone' mode.
NR override	④	13.5 ±2	In installation, and Cat. 35 'Dolby Tone' mode.
NR override	④	18	In Cat. 35, except 'Dolby Tone' mode.

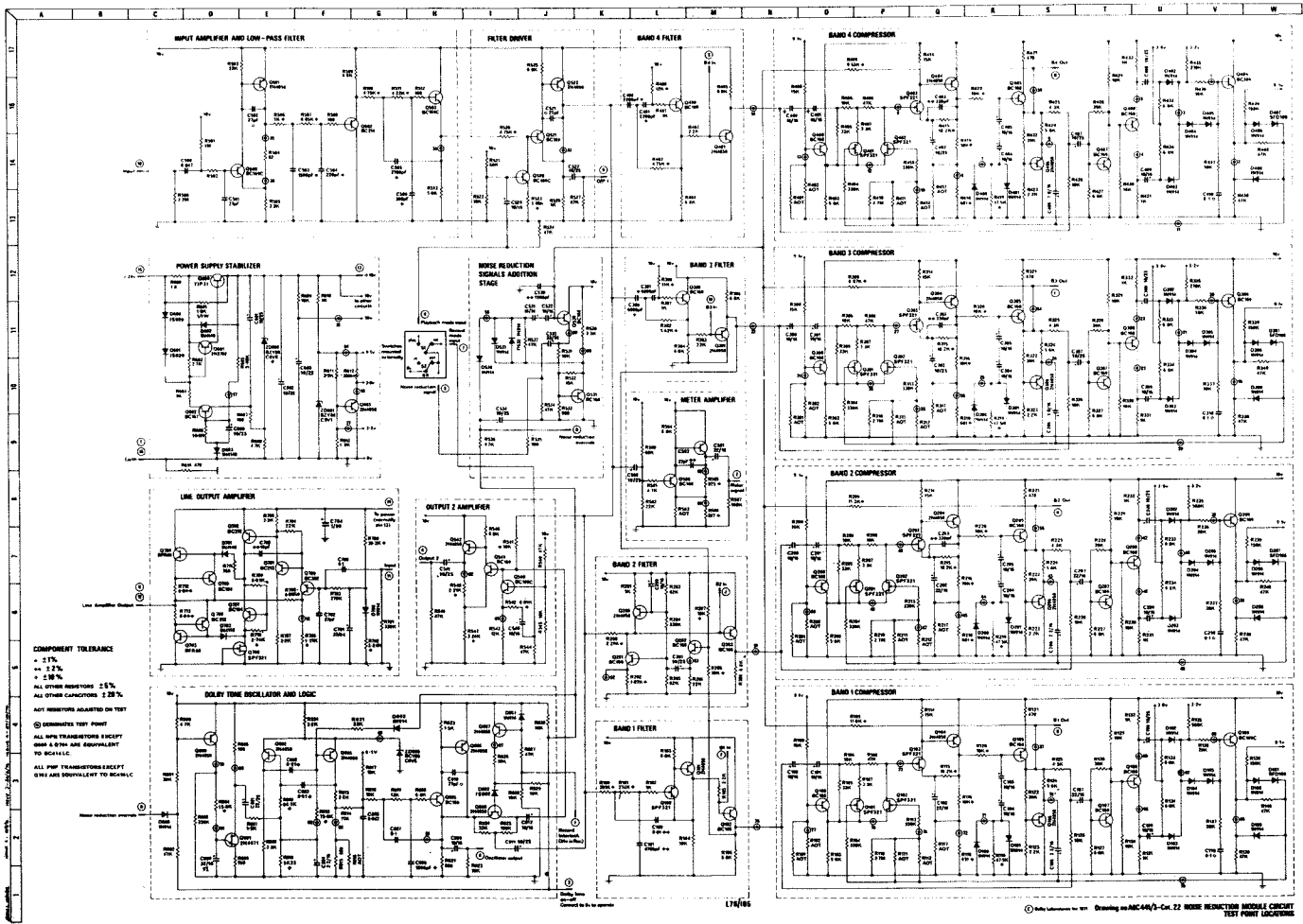

COMPONENT TOLERANCE
 ± 2%
 ± 1%
 ± 0.5%
 ALL OTHER RESISTORS 25%
 ALL OTHER CAPACITORS 20%
 ALL CAPS ADJUSTED ON TEST
 ⊙ DENOTES TEST POINT
 ALL SMD TRANSISTORS EXCEPT
 805 & 8051 ARE EQUIVALENT
 TO SCHEMATIC
 ALL PNP TRANSISTORS EXCEPT
 8051 ARE EQUIVALENT TO SCHEMATIC

© 1997 by Motorola, Inc. All rights reserved. Drawing No. MC-447-01-2 NOISE REDUCTION MOBILE CIRCUIT TEST POINT LOCATIONS

13.1

SECTION 13

CAT. NO. 35 NRM TEST SET

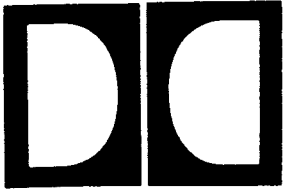

DOLBY LABORATORIES INC

A-TYPE NOISE REDUCTION SYSTEM

OPERATING INSTRUCTIONS

NRM Test Set, Cat. No. 35

NRM Tester, Cat. No. 35A

Test Extender, Cat. No. 35B

The NRM Test Set comprises the Noise Reduction Module Tester (Cat. No. 35A) and the Test Extender (Cat. No. 35B). The Test Set is designed to test all major functions of the Noise Reduction Module (Cat. No. 22), to check the ripple level of the rough d. c. supply which powers the module, and to verify the accuracy of level setting meters used in the equipment in which the module is installed.

Testing of Noise Reduction Modules

1. Brief operating instructions are given on the front of the Test Extender. More detailed instructions and explanations are provided below.
2. Remove the Cat. No. 22 Noise Reduction Module to be tested. In 360 Series units, access to the module is provided by removal of the front cover plate.
3. Plug the module into the connector on the NRM Tester.
4. Plug the Test Extender into the connector from which the module was removed.
5. Plug the cable connector from the Test Extender into connector JF1 on the NRM Tester. This provides power to the NRM Tester and the module under test. The cable also provides a return signal from the NRM Tester for meter calibration purposes.
6. For completely self-contained operation of the NRM Tester, set the oscillator switch on the rear of the tester to the internal position. In this mode the signal used in the various tests is provided by the internal Dolby Tone oscillator in the module.
7. To test the various circuit functions of the module, rotate the switch S1 progressively clockwise, beginning at 24V NOISE. Stop at COMPRESSOR, and rotate switch S2 through all of its positions, beginning at GAIN, BAND 1. Following the compressor tests,

proceed with switching S1 clockwise. The meter should read TEST (or the green LED should be on) in all positions except NOISE. The two noise positions should provide meter readings in the band marked NOISE (in this case, the green LED also should be on).

NOTE: Latest models of the Cat. No. 35 use an LED display in place of the meter, providing greater reliability and improved accuracy. All tests are satisfactory if the green LED is on; the red LED indicates a fault condition. The yellow LED shows a condition analogous to the meter pointer being exactly on the tolerance limits, and shows that the module almost certainly can be used with satisfactory results, but should be returned for overhaul as soon as practical. Note that if the amber LED is on for all tests (equivalent to all test results being marginal), this probably signifies a low or high Dolby test tone oscillator and no malfunction in the Dolby circuit itself. The green LED covers a range ± 0.5 dB about the desired value, and the yellow LED covers a further ± 0.5 dB. The black area on the meter version also indicated a ± 0.5 dB range about nominal value.

Testing of Meters

1. To check the calibration of level setting meters, set switch S1 to OSC position. 360 Series meters or other meters associated with the module should read 185 nWb/m (Dolby Level).
2. On 360 Series units the calibration of the DIN mark on the meter can be checked by pressing the DIN CHECK button (OSC position of S1) on the NRM Tester. The 360 Series meter should be read from directly in front; parallax should not be corrected for when making DIN readings.

Details of Tests

In the tests, the pin connections and a. c. and d. c. voltages brought out from the Cat. No. 22 module to the test point on the rear of the NRM Tester are given in parentheses.

1. In the 24V position of S1, the ripple on the income rough d. c. supply is checked (pin 15, 600 mV a. c. maximum, 20-28V d. c.).
2. In the 18V position of S1, the ripple and noise on the output of the module voltage regulator are checked (pin 13, 400 uV a. c. maximum, 17.7-18.5V d. c.).
3. In the OSC position of S1, the output of the module oscillator is checked (pin A, 290-310 mV a. c. , 0V d. c.). In this position the

signal from pin A is also amplified in the NRM Tester to 1.85V a. c. 0V d. c. , at connector JF1 and is used to check the calibration of level setting meters (Dolby Level, 185 nWb/m). When the DIN CHECK button is pressed, the signal from pin A is amplified to 3.2V at JF1 (corresponding to 320nWb/m). (The LED display is switched off for this test).

4. In the OUT 1 position of S1, the signal from the module oscillator (pin A) is fed into the module input (pin 10), and the main-path signal circuit is checked at Output 1 (pin 6, 290-310 mV a. c. , 0V d. c.), which follows the playback noise reduction signal combination point.
5. In the METER AMP position of S1, the signal from the module oscillator (pin A) is fed into the module input (pin 10), and the output of the meter amplifier is checked (pin 2, 1.8-1.9V a. c. , 0V d. c.).
6. In the OUT 2 position of S1, the signal from the module oscillator (pin A) is fed into the module input (pin 10), and the main-path signal circuit is checked at Output 2 (pin 4, 480-520 mV a. c. , 0V d. c.), which follows the record noise reduction signal combination point.
7. In the DOLBY TONE position of S1, the module oscillator is FM modulated to produce the Dolby Tone, the electronic switch Q808 is energized, and the signal at Output 2 is checked (pin 4, 480-520 mV a. c. , 0V d. c.).
8. In the LINE AMP position of S1, the signal from the module oscillator (pin A) is fed into the line amplifier input (pin 11), and the output of the line amplifier is checked (pins 12, N; 1.9-2.1V a. c. , 8-10 d. c.).
9. For the compressor tests, switch S1 is set at COMPRESSORS. In this position, the signal from the module oscillator (pin A) is attenuated to 2 mV, 10 mV and 40 mV for the GAIN, LAW 1, and LAW 2 tests, respectively (S2). The attenuated signal is fed into the input of the compressor selected by S3 (pins F, J, M and S for bands 1-4, respectively). The outputs of the compressors are checked as follows (pins B, H, L and R for bands 1-4, respectively):
 - A. GAIN, 16 - 18 mV a. c. , 6 - 8V d. c.
 - B. LAW 1, 55 - 63 mV a. c. , 6 - 8V d. c.
 - C. LAW 2, 67 - 77 mV a. c. , 6 - 8V d. c.

10. In the RECORD position of S1, the module is connected in the record mode (pin 8 connected to pin 7), and a signal from the module oscillator (pin A) is attenuated to 3 mV and fed into the module input (pin 10). The output of the module is checked at Output 2 (pin 4, 15-17 mV a. c. , 0V d. c.).
11. In the NR OUT position of S1, the noise reduction signal is disabled and a signal from the module oscillator (pin A) is attenuated to 3 mV and fed into the module input (pin 10). The output of the module is checked at Output 2 (pin 4, 4.8-5.2 mV a. c. , 0V d. c. ; i. e. 9.5-10.5 dB lower than in test 10 above).
12. In the PLAY position of S1, the module is connected in the playback mode (pin 8 connected to pin 9) and a signal from the module oscillator (pin A) is attenuated to 3 mV and fed into the module input (pin 10). The output of the module is checked at Output 2 (pin 4, 1.5-1.7 mV a. c. , 0V d. c. ; i. e. 9.5-10.5 dB lower than in test 11 above).

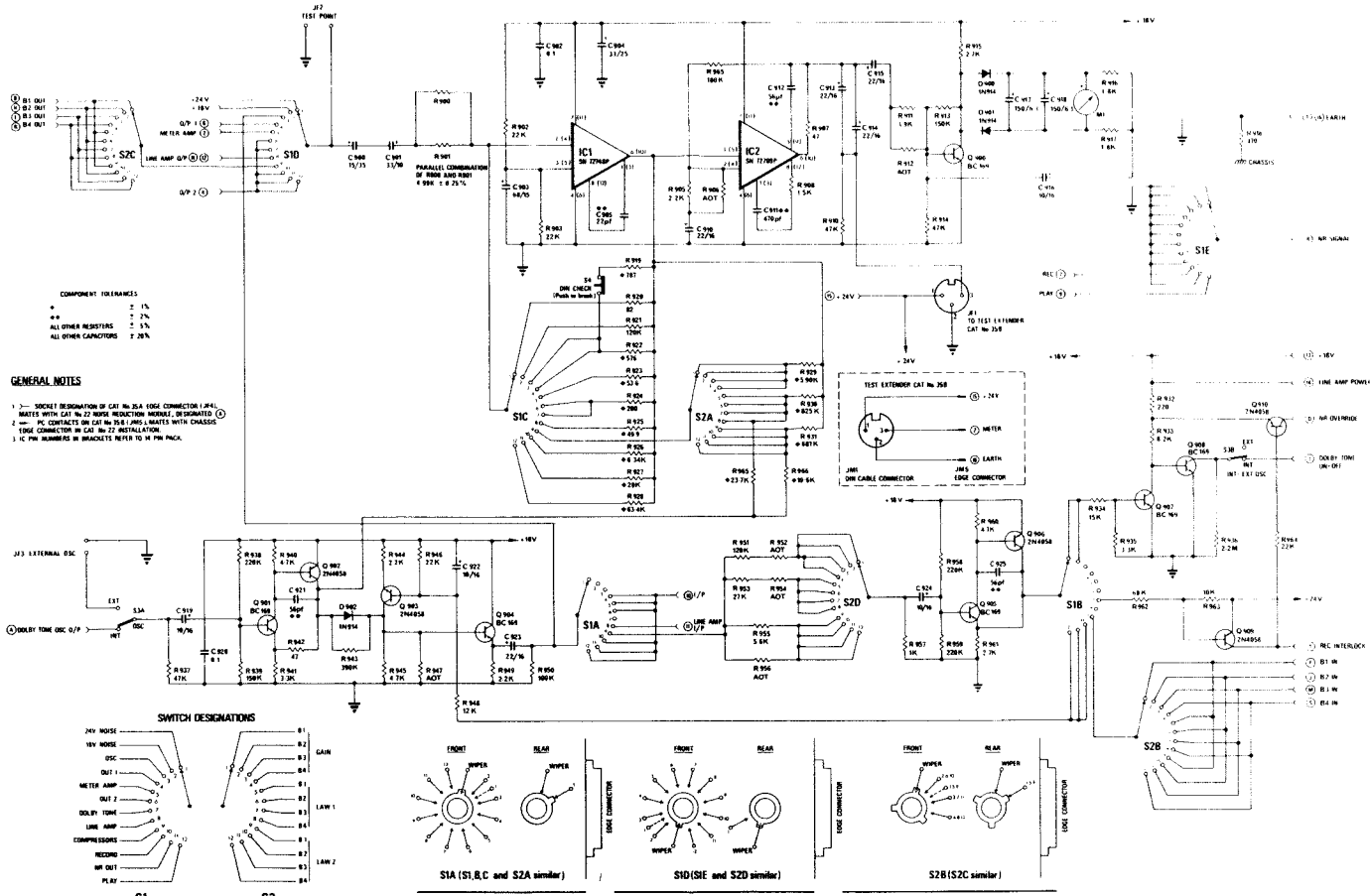

- COMPONENT TOLERANCES**
- * ± 1%
 - ** ± 1%
 - *** ± 5%
 - ALL OTHER RESISTORS ± 5%
 - ALL OTHER CAPACITORS ± 20%

- GENERAL NOTES**
1. SOCKET DESIGNATION OF CAT. NO. 35A EDGE CONNECTOR (P41) MATES WITH CAT. NO. 22 NOISE REDUCTION INTERF. DISMOUNTED (C)
 2. PC CONTACTS ON CAT. NO. 35A LINE AMPS MATES WITH CHASSIS
 3. EDGE CONNECTOR IN CAT. NO. 22 INSTALLATION
 4. PC PIN NUMBERS IN BRACKETS REFER TO PC PIN PACK.

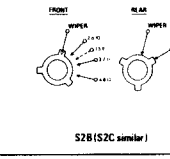
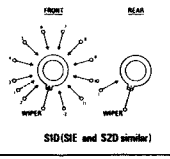
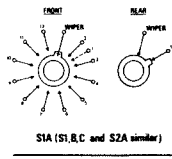
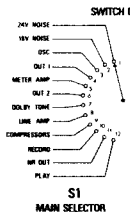

- SWITCH NOTES**
1. ALL WAFERS ARE MOVED FROM THE KNIFE END.
 2. WAFERS ARE SHOWN RELATIVE TO EDGE CONNECTOR.
 3. WAFERS FOR 24V NOISE SHOWN IN BLACK. ALL OTHER WAFERS HAVE SHORTRITE BLANKS.
 4. WAFERS ARE LETTERED IN ALPHABETIC ORDER FROM THE KNIFE END.

NRM TEST SET CAT No.35 CIRCUIT DIAGRAM
 © Bell Laboratories Inc 1977 Dwg No ADC 613

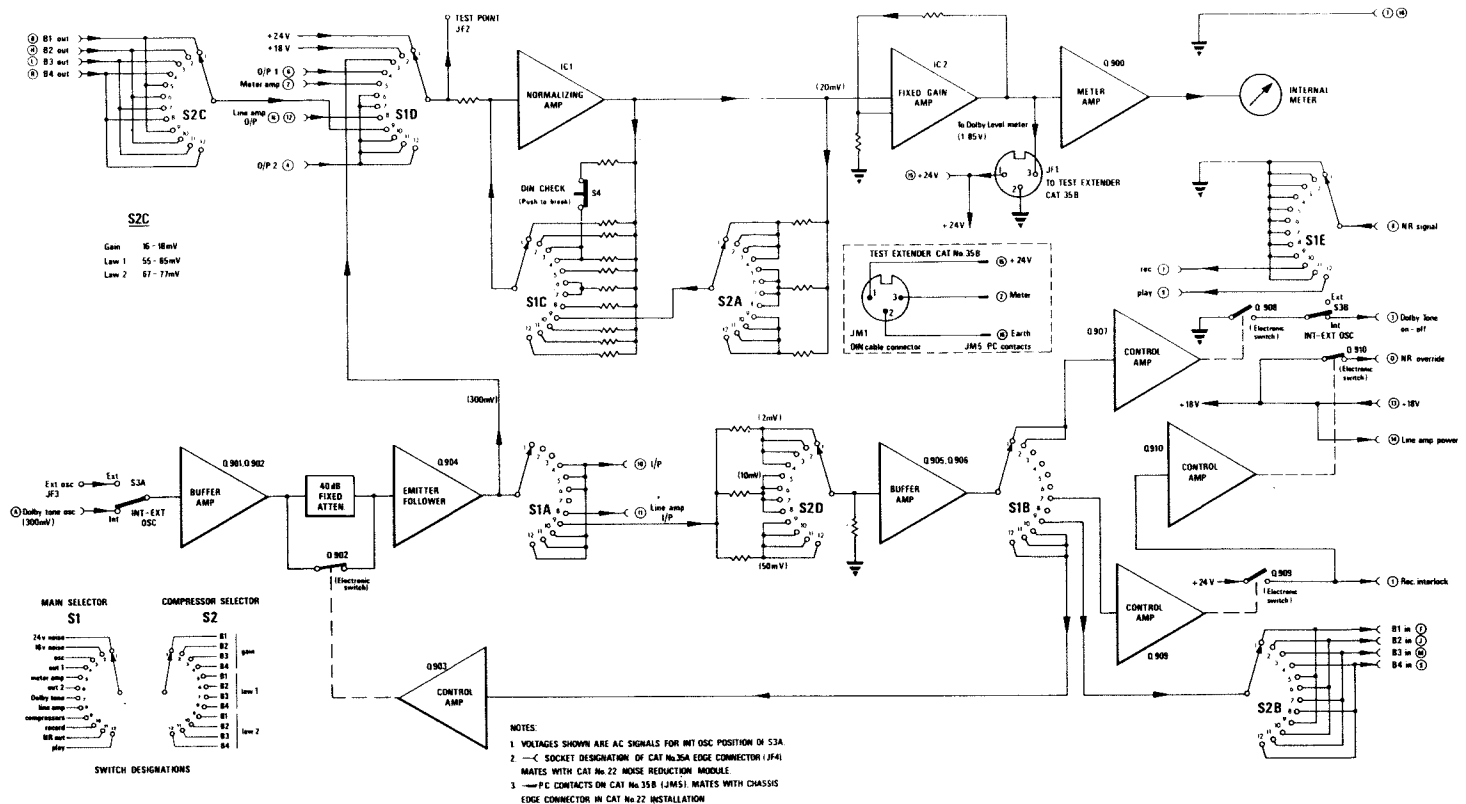

NRM TEST SET CAT No.35 BLOCK DIAGRAM
© Dalby Laboratories Inc 1972 Drg.No. A1B 716