

Film-Tech

The information contained in this Adobe Acrobat pdf file is provided at your own risk and good judgment.

These manuals are designed to facilitate the exchange of information related to cinema projection and film handling, with no warranties nor obligations from the authors, for qualified field service engineers.

If you are not a qualified technician, please make no adjustments to anything you may read about in these Adobe manual downloads.

www.film-tech.com

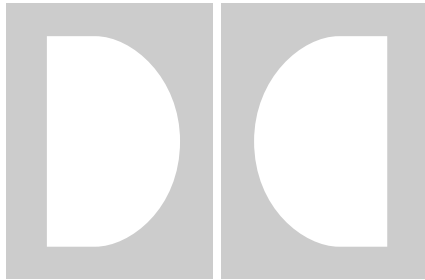

Dolby

Model CP65

Cinema Processor

Installation and Alignment Instructions

Issue 4

Part No. 91234

Dolby Laboratories Inc

U.S. Headquarters

Dolby Laboratories Inc
100 Potrero Avenue
San Francisco, CA 94103-4813
Telephone 415-558-0200
Facsimile 41-863-1373
www.dolby.com

U.K. European Office

Dolby Laboratories Inc
Wootton Bassett
Wiltshire SN4 8QJ England
Telephone (44) 1793-842100
Facsimile (44) 1793-842101

DISCLAIMER OF WARRANTIES: Equipment manufactured by Dolby Laboratories is warranted against defects in materials and workmanship for a period of one year from the date of purchase. All warranties, conditions or other terms implied by statute are excluded to the fullest extent allowed by law.

LIMITATION OF LIABILITY: It is understood and agreed that Dolby Laboratories' liability whether in contract, in tort, under any warranty, in negligence or otherwise shall not exceed the cost of repair or replacement of the defective components and under no circumstances shall Dolby Laboratories be liable for incidental, special, direct, indirect or consequential damages (including but not limited to damage to software or recorded audio or visual material), or loss of use, revenue or profit even if Dolby Laboratories or its agents have been advised, orally or in writing, of the possibility of such damages.

Dolby and the double-D symbol are registered trademarks of Dolby Laboratories.

©1999 Dolby Laboratories Inc

Issue 4
S99/9563/12772
Part No. 91234

Table of Contents

INTRODUCTION	V
CP65	V
CP65-A	V
CP65-300	V
About this manual	V
 SECTION 1	
EQUIPMENT REQUIRED	1-1
 SECTION 2	
INITIAL SET-UP AND INSTALLATION	2-1
Wiring Diagrams	2-3
Jumpers on Boards	
Cat. No. 441	2-5
Cat. No. 242	2-6
Cat. No. 249	2-6
Cat. No. 443	2-7
CP65 Backplane	2-8
Cat. No. 241	2-10
Card Descriptions	2-11
IEC Notices	2-15
Hum Problems	2-16
 SECTION 3	
AN OVERVIEW OF THE ALIGNMENT PROCEDURE	3-1
1. Aligning the A-Chain	3-1
2. Aligning the B-Chain	3-1
 SECTION 4	
A-CHAIN ALIGNMENT	4-1
a. Preliminary Procedures	4-2
b. Optical Preamplifier Adjustments	4-6
c. Magnetic Preamplifier Adjustments	4-20
 SECTION 5	
B-CHAIN ALIGNMENT	5-1
a. Setting Room Equalization	5-2
b. Adjusting L,C,R Gain	5-18
c. Setting Mono Gain	5-20
d. Subwoofer Alignment	5-22
e. Surround Equalization Alignment	5-32
f. Adjustment of Surround Delay	5-42
g. Adjustment of Bypass Gain	5-44
h. Adjustment of Non-sync Gain	5-48
i. Adjustment of Mono Gain and Equalization	5-52
j. Final Checks	5-54

SECTION 6
REFERENCE BLOCK DIAGRAMS 6-1

APPENDIX A
Checking Phasing of Speakers

APPENDIX B
Effect of Changes in Slit Height on Slit Losses

APPENDIX C
CP65M (Mono) Instructions

APPENDIX D
Backplane Connections Listing

INTRODUCTION

This manual contains essential information on the installation and alignment of the CP65 Cinema Sound Processor. The CP65 supersedes the CP55 and is available in three versions:

CP65

The standard configuration, equipped for the reproduction of the following sound formats

- **01 Mono**—for all optical prints of any vintage with conventional mono optical (“Academy”) sound-tracks.
- **04 Dolby Stereo A-type**
- **05 Dolby Stereo SR**
- **10 Dolby Stereo Digital**—with the addition of an external digital adapter
- **60 Non-sync**
- **Mag / Aux**—This format may be programmed in a number of different ways. Possible options include:
 - Magnetic sound-tracks without A-type noise reduction.
 - Extra sound sources, such as a Magnetic follower/dubber, PA microphone with preamp or a “stereo” synthesizer.

CP65-A

Equipped with A-type noise reduction only. Reproduces the same formats as the standard CP65 with the exception of **05 Dolby Stereo SR**.

CP65-300

Equipped with two Cat. No. 300 modules in place of the Cat. No. 350 SR modules. Cat. No. 300 SR/A processors contain both A-type and SR circuits and these additional two channels of A-type along with the channels in the Cat. No. 222 modules are used to decode 70 mm Dolby Stereo magnetic soundtracks (format 42).

About this manual

This manual is intended to be used by individuals who are qualified in the area of cinema sound service. The basic day-to-day operation of the CP65 is covered in the **CP65 Operator’s Guide**.

This installation and alignment manual covers the procedures necessary to ensure that the theatre sound system is accurately aligned to standards that have been established by Dolby Laboratories. Following these procedures will ensure that the theatre sound system will accurately reproduce the soundtrack as the director and sound mixers intended.

The Dolby Cinema Processor is the central element of the theatre sound system. The projector, the Dolby Processor, the power amplifiers and the loudspeakers, as well as the auditorium itself, must be considered when aligning the system for optimum performance.

The system alignment procedure is divided into two parts—the A-chain alignment which covers the projector, optical preamplifier, and Dolby noise reduction adjustments—and the B-chain alignment which covers the portions of the system from the room equalization circuits to the CP65 fader through to the loudspeakers.

The alignment instructions in this Manual are presented in three columns. The first column, **Action**, contains a drawing of the item to be adjusted and a caption containing a brief description of the action to be taken. The second column, **Indication**, contains a visual indication of the desired results, where applicable. The third column, **Notes**, contains information which amplifies and supplements the other two columns.

If you are familiar with alignment of other Dolby Cinema Processors you need to follow only the information in the first two columns. If you are unfamiliar with the equipment or face special situations that require complete information you should consult the **Notes** column.

CAUTION

This Installation Manual is for use by qualified personnel only. To avoid electric shock do not perform any servicing other than that contained in the Operator's Guide unless you are qualified to do so.

SECTION 1 EQUIPMENT REQUIRED

- a. Dual-trace oscilloscope with X-Y facilities.
- b. 1/3 Octave Real Time Spectrum Analyzer (RTA) with calibrated microphone. (Preferably multiple microphones and a multiplexer should be used.)
- c. Sound Pressure Level Meter (with slow time-constant and C weighting scale).
- d. Cat. No. 85C pink noise generator.
- e. Cat. No. 67 extender for the equalizer modules.
- f. Test Films (available from Dolby Laboratories or equipment dealers). We recommend that you make loops of these test films, sufficiently long to go through the entire projector film path so that azimuth and lateral film position adjustments can be made accurately.

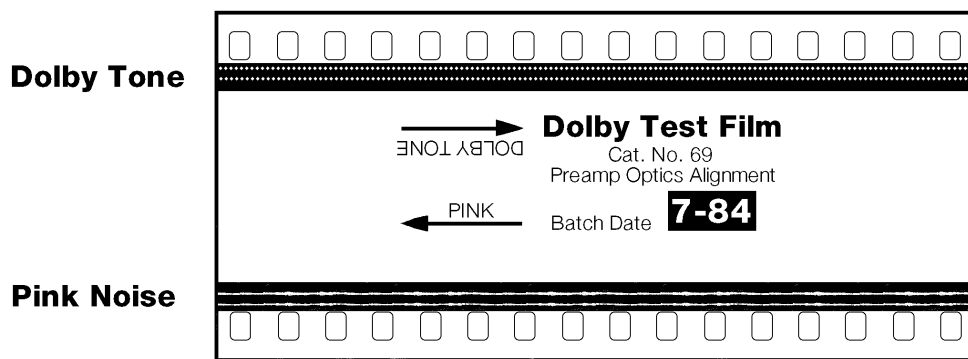

(1) Dolby Tone and Pink Noise — Cat. No. 69

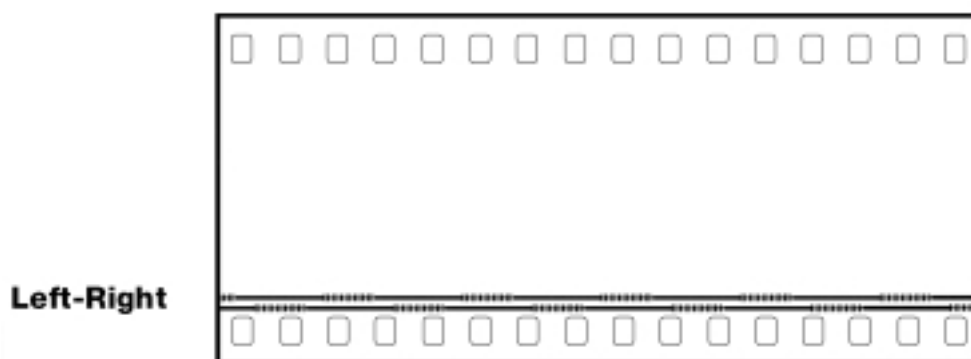

(2) 1kHz, 100% Modulation, Left/Right — Cat. No. 97

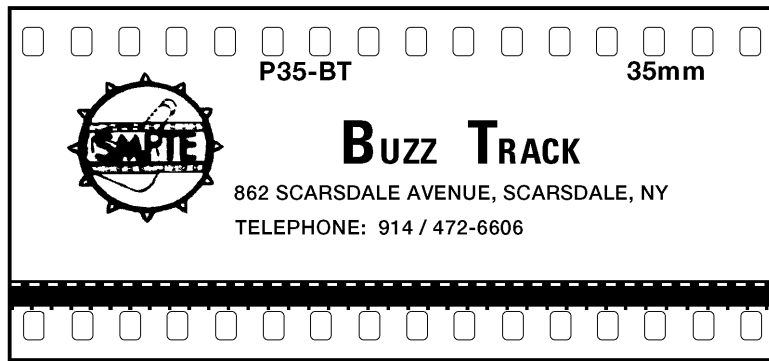

(3) SMPTE Buzz Track

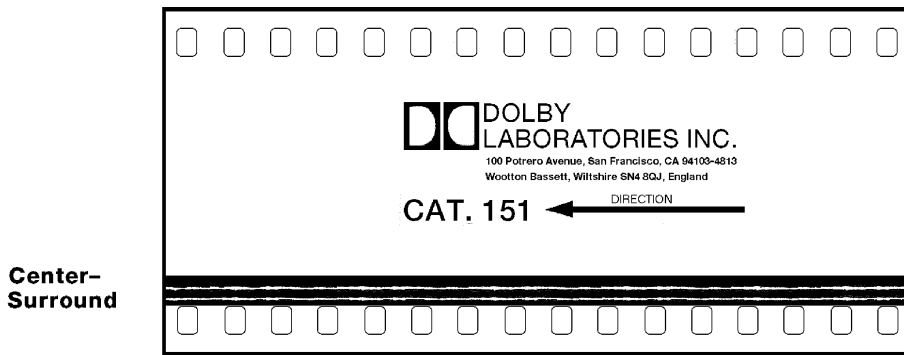

(4) Stereo Optical Surround Level — Cat. No. 151

g. The following films can also be purchased from Dolby Laboratories or a cinema equipment dealer. The films are optional items that are used in final system sound verification:

(1) "Jiffy" Test Film — Cat. No. 251

(2) "Listen . . ." Film — Cat. No. 351.



SECTION 2

INITIAL SET-UP AND INSTALLATION

Before you remove or replace the Cat. No. 240A Optical Pre-Amp or the Cat. No. 249 Power Supply Card, first disconnect AC power from the CP65 to protect the speakers and the CP65 from damage. For all other modules in the CP65, first switch to BYPASS; you can then safely remove or replace the desired card without disconnecting power from the CP65.

Do **NOT** connect the CP65 to mains power until all connections have been made and all jumpers have been installed (see **STEP 9** later in this section).

STEP 1 If air-conditioning noise is audible in the theatre, arrange for lubrication of the motor, fan bearings, adjustment of belts and drives, and cleaning of filters to reduce the ambient noise to a minimum.

If the CP65 replaces an existing cinema sound system, play a typical film before you remove the old system so you will have a benchmark for comparison to the new system and as a check of the positioning of the exciter lamp, the focusing of the sound track lens, and the condition of the solar cell.

Before you run the film:

- Verify that the existing power amplifiers are in good working order.
- Verify that the existing speakers are in good working order, and that there is no loose or missing hardware or structural members in the enclosures.
- Verify that all wiring is present and properly connected and that crossovers are operating and are correctly adjusted.
- Check the phasing of the speaker connections (see Appendix A).
- Verify that there are adequate earth (ground) connections.
- Verify that radio interference problems are adequately resolved.

STEP 2 While you are running the film, listen carefully in various parts of the theatre for audio system problems:

- Hum.
- Noise, clicks, pops.
- Distortion.
- Poor tonal balance (lack of high-frequency or bass content).

These problems must be resolved before you can proceed to the next step in the installation.

STEP 3 To avoid heat problems, do not locate the CP65 immediately above or below the power amplifiers.

Always leave a 1U (43 mm, 1.75") space above and below the CP65 to provide adequate ventilation. Install an air guide or baffle to deflect hot air from equipment below the CP65.

Locate the power amplifiers away from the Cat. No. 240A optical preamplifier to avoid hum pickup problems.

- STEP 4** Disconnect power from the existing cinema sound equipment.
- STEP 5** Disconnect all cabling from the existing cinema sound processing system, but do not disconnect the wiring from power amplifiers, etc.
- STEP 6** Check that the CP65 voltage selector switch is set correctly for your mains voltage and that the correct fuses are installed. (The selector switch is located on the rear of the Cat. No. 259 Power Supply and can be seen through the backplane.)

DISCONNECT THE CP65 FROM POWER BEFORE YOU TURN THE SELECTOR SWITCH FROM ONE POSITION TO ANOTHER.

The CP65 accepts both 50 Hz and 60 Hz power. The mains voltages must fall within the following limits:

<u>Voltage Setting</u>	<u>Acceptable Voltage Range</u>	<u>Fuse</u>	<u>Type</u>
100 VAC	85-110 VAC	1.25 A	1/4" x 1-1/4" slow-blow
120 VAC	102-132 VAC	1.25 A	1/4" x 1-1/4" slow-blow
140 VAC	119-154 VAC	1.25 A	1/4" x 1-1/4" slow-blow
200 VAC	170-220 VAC	T 630 mA	5 x 20mm time lag
220 VAC	187-242 VAC	T 630 mA	5 x 20mm time lag
240 VAC	204-265 VAC	T 630 mA	5 x 20mm time lag

NOTE

Follow all local codes and regulations covering electrical wiring. It is recommended that conduit be used for wiring runs.

- STEP 7** All signal connections (except those to automation connector J18 -- see the following step) are made by soldering the leads to fanning strips (solder tags) that are supplied with the CP65. The fanning strips with the soldered wiring are fastened in place at the terminal blocks shown on the wiring diagram.
- STEP 8** If you plan to make use of the automation interface in the CP65, there are two methods you can follow.

If both remote switches and their accompanying indicators for format, mute, and local / remote fader control are required you should use the 25 way D type connector J18. If only remote switches are required connections can be made to TB1 using the fanning strips supplied with the CP65.

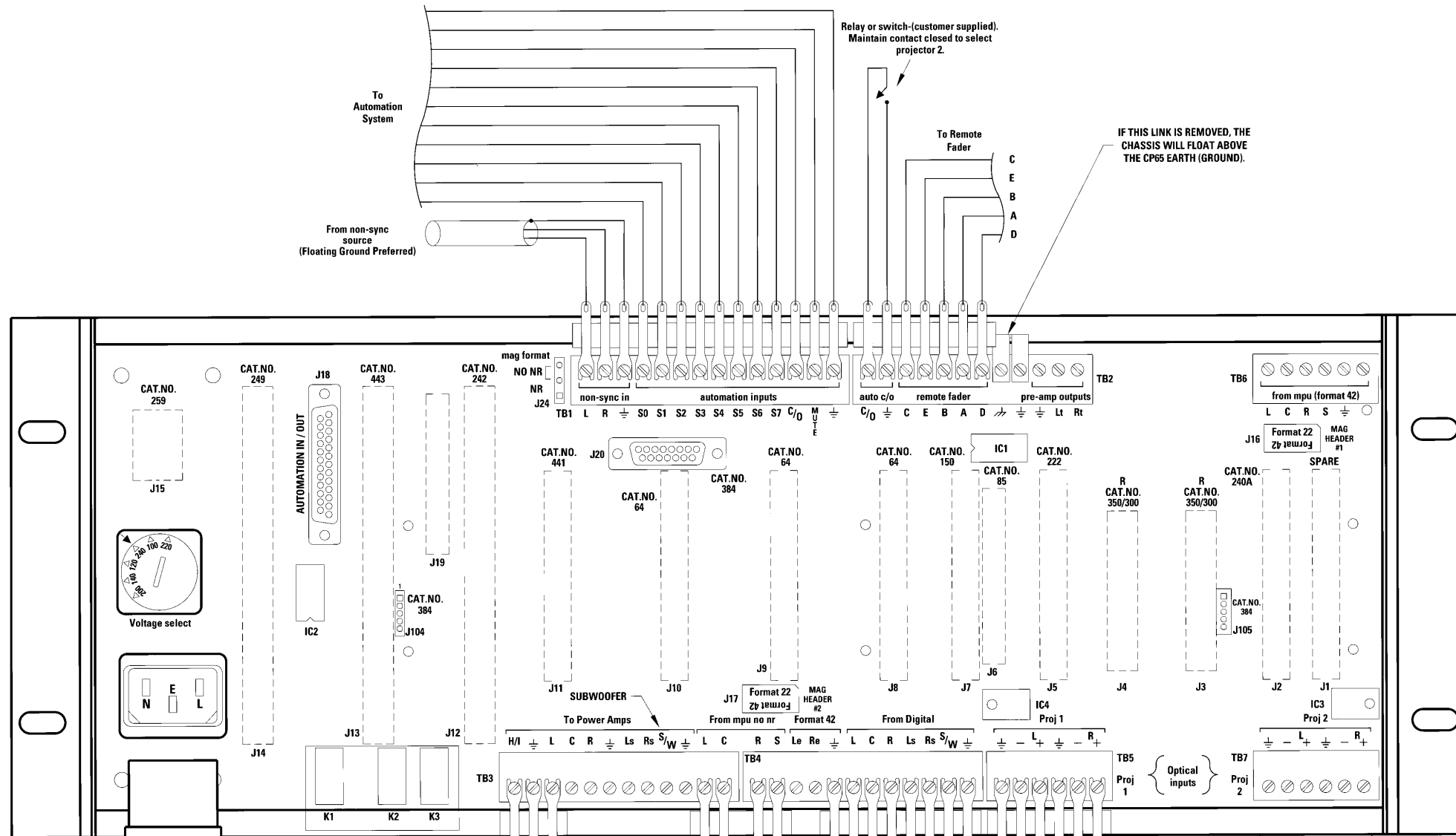

NOTE:
 1. Remove power card before selecting an alternative voltage
 2. Power cord earth wire-connector is connected to the CP65 frame.
 3. Select switch is shown in 240V position.

Use 2-conductor shielded cables such as Belden 8451 or an equivalent type wire. For balanced input power amplifiers, ensure that amplifier commons are connected to CP65 ground, either through the rack or via a wire installed for that purpose.

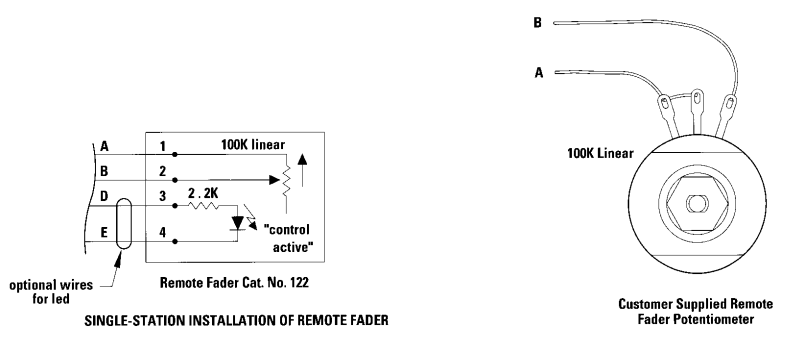
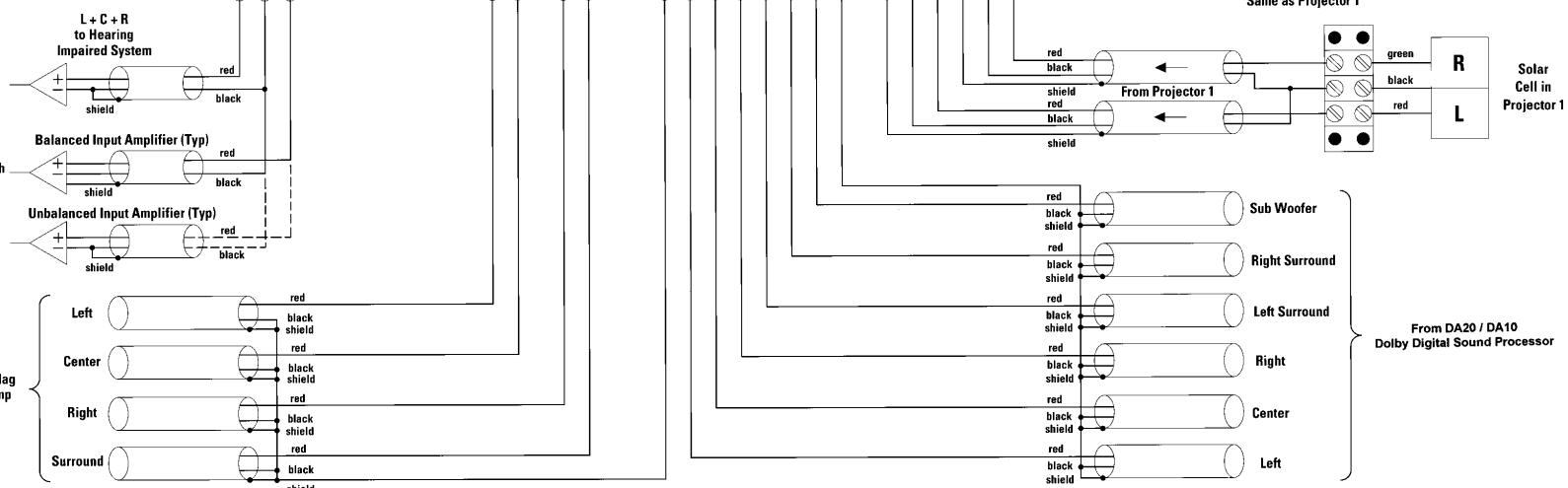

SINGLE-STATION INSTALLATION OF REMOTE FADER

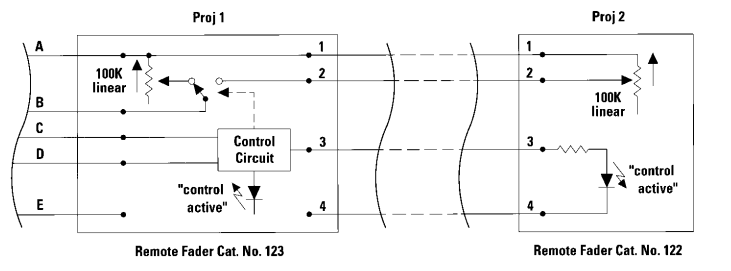

TWO-STATION INSTALLATION OF REMOTE FADER (EXPANDABLE TO ANY NUMBER)

- NOTE:**
1. FOLLOW ALL LOCAL ELECTRICAL AND BUILDING CODES.
 2. USE EARTHED (GROUNDED) CONDUIT WHEREVER POSSIBLE. AVOID ROUTING SIGNAL WIRING NEAR ELECTRIC MOTORS, RECTIFIERS, POWER WIRING, DIMMER WIRING OR OTHER SOURCES OF ELECTRICAL NOISE.
 3. CHECK EARTHING (GROUNDING) OF POWER AMPLIFIERS. FOR BALANCED INPUT POWER AMPLIFIERS, CONNECT THE AMPLIFIER COMMONS TO THE CP65 CHASSIS EARTH (GROUND) EITHER THROUGH THE RACK OR VIA A DIRECT WIRE CONNECTION THAT IS INSTALLED FOR THIS PURPOSE.
 4. USE BELDON 8451 2-CONDUCTOR SHIELDED WIRING FOR ALL SIGNAL WIRING (TWO 22AWG 7x30 STRANDED CONDUCTORS, TINNED COPPER, POLYPROPYLENE INSULATED, TWISTED PAIR, 22AWG STRANDED TINNED COPPER DRAIN WIRE, BELDFOIL ALUMINUM-POLYESTER SHIELD, PAPER WRAP, 100% SHIELD COVERAGE, NOMINAL OD 0.135in. (3.43mm), 34pf PER FOOT CONDUCTOR TO CONDUCTOR (111 pf PER METER).
 5. USE 22AWG WIRING FOR FADER AND OTHER CONTROL WIRING (ONE 22AWG 7x30 STRANDED CONDUCTORS, TINNED COPPER, PVC OR EQUIVALENT INSULATED, PVC OR EQUIVALENT JACKET). IF DESIRED, EQUIVALENT RIBBON CABLE MAY BE USED FOR MULTICONDUCTOR CONNECTIONS.

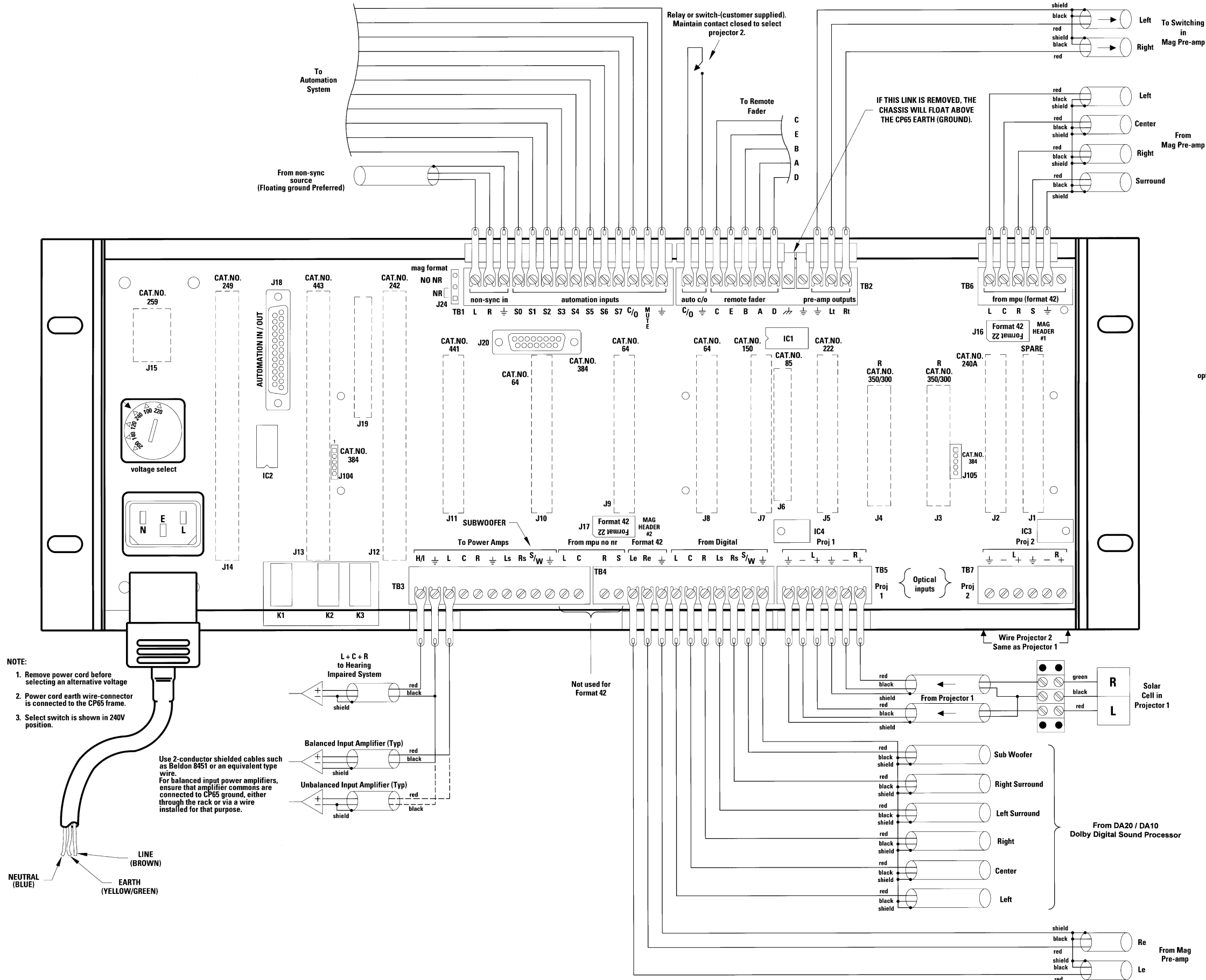

NOTE:
 1. Remove power cord before selecting an alternative voltage
 2. Power cord earth wire-connector is connected to the CP65 frame.
 3. Select switch is shown in 240V position.

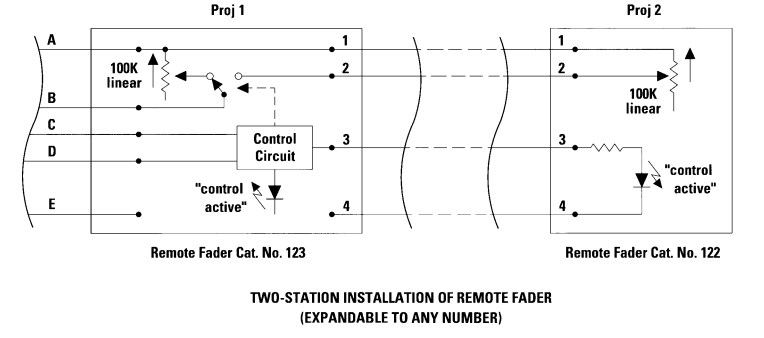
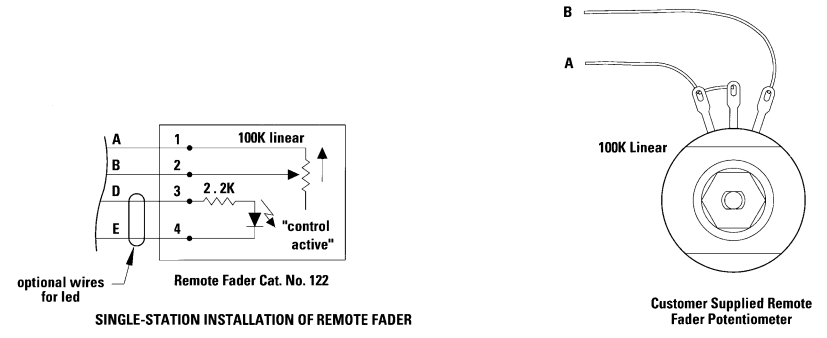
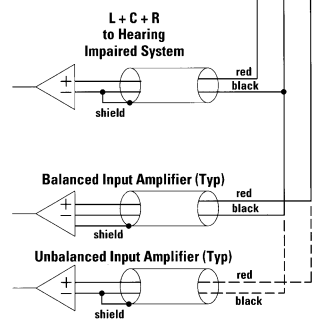
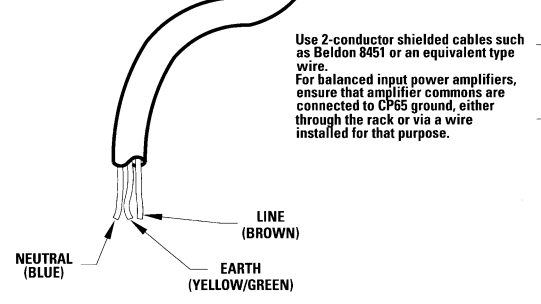

NOTE:

1. FOLLOW ALL LOCAL ELECTRICAL AND BUILDING CODES.
2. USE EARTHED (GROUNDED) CONDUIT WHEREVER POSSIBLE. AVOID ROUTING SIGNAL WIRING NEAR ELECTRIC MOTORS, RECTIFIERS, POWER WIRING, DIMMER WIRING OR OTHER SOURCES OF ELECTRICAL NOISE.
3. CHECK EARTHING (GROUNDING) OF POWER AMPLIFIERS. FOR BALANCED INPUT POWER AMPLIFIERS, CONNECT THE AMPLIFIER COMMONS TO THE CP65 CHASSIS EARTH (GROUND) EITHER THROUGH THE RACK OR VIA A DIRECT WIRE CONNECTION THAT IS INSTALLED FOR THIS PURPOSE.
4. USE BELDON 8451 2-CONDUCTOR SHIELDED WIRING FOR ALL SIGNAL WIRING (TWO 22AWG 7x30 STRANDED CONDUCTORS, TINNED COPPER, POLYPROPYLENE INSULATED, TWISTED PAIR, 22AWG STRANDED TINNED COPPER DRAIN WIRE, BELDFOIL ALUMINUM-POLYESTER SHIELD, PAPER WRAP, 100% SHIELD COVERAGE, NOMINAL OD 0.135in. (3.43mm), 34pF PER FOOT CONDUCTOR TO CONDUCTOR (111 pF PER METER).
5. USE 22AWG WIRING FOR FADER AND OTHER CONTROL WIRING (ONE 22AWG 7x30 STRANDED CONDUCTORS, TINNED COPPER, PVC OR EQUIVALENT INSULATED, PVC OR EQUIVALENT JACKET), IF DESIRED, EQUIVALENT RIBBON CABLE MAY BE USED FOR MULTICONDUCTOR CONNECTIONS.

STEP 9 Next, check the jumpers in the following locations:

Cat. No. 441 Surround Equalization, Subwoofer and SR•D Interface Card (if fitted).

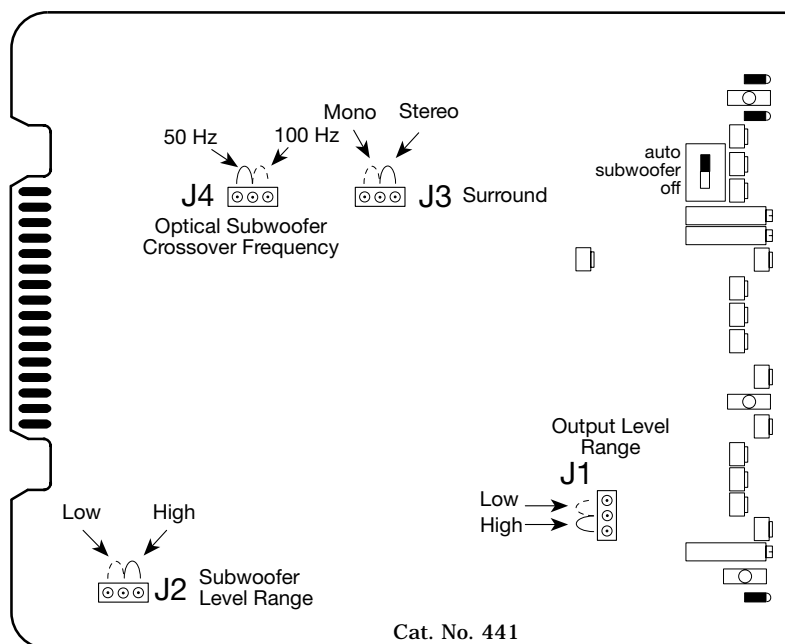

The Cat. No. 441 has four jumpers that are used to configure the card to suit the installation in which it is used.

J1 Right Surround output level sets the output gain range for the right surround channel. J1 is set at the factory for a power amplifier input sensitivity of between 90 mV and 1.23 V. If the power amplifiers used in the installation are very sensitive (10 mV to 100 mV input sensitivity), it may be necessary to move this jumper to the low output position.

J2 Subwoofer output level control sets the output gain range for the subwoofer channels. J2 is set at the factory for a power amplifier input sensitivity of between 90 mV and 1.23 V. If the power amplifiers used in the installation are very sensitive (10 mV to 100 mV input sensitivity), it may be necessary to move this jumper to the low output position.

J3 Surround Mono / Stereo selects stereo or mono surround operation. Set J3 to the Stereo position if your cinema is equipped with separate power amplifiers and speaker wiring for left and right surrounds. Note that stereo surround signals are only available in format 10 Dolby Stereo digital. Install this jumper in the stereo or mono position according to your installation.

J4 Subwoofer upper frequency limit sets upper frequency limit of the subwoofer channel in optical or non-sync to either 50 or 100 Hz. The recommended setting of this jumper depends on the type of screen speakers in your cinema.

If you have the older horn-loaded type of speaker (such as Altec A-4), the jumper should be set for 100 Hz and the equalization for the screen speakers rolled off below this frequency. These settings will remove frequencies from the screen speakers that they cannot gracefully reproduce at full power and send them to the subwoofer which is better able to handle them.

If you have the newer direct radiator type of screen speakers, set J4 to the 50 Hz position and adjust the equalization of the screen speakers to roll off below that frequency.

Cat. No. 242, B-Chain Card

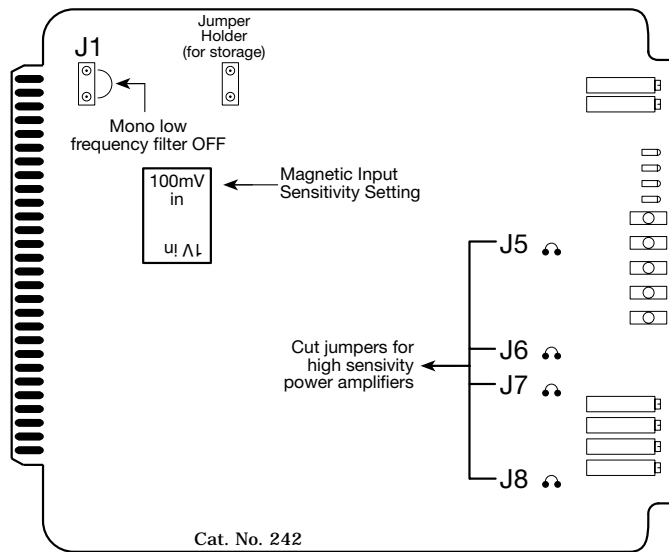

J1 Mono LF cut In/Out: selects optional low frequency cut when Mono (format 01) is selected. In some cases the extended low frequency response may appear to be out of balance with the restricted high frequency response needed for the correct reproduction of mono optical sound-tracks. Move J1 to the **ON** position to attenuate the low frequency response.

J5, J6, J7, J8 Output levels: Jumpers W5, W6, W7, and W8 are set at the factory for a power amplifier input sensitivity of between 90 mV and 1.23 V. If the power amplifiers used in the installation are very sensitive (10 mV to 100 mV input sensitivity), it may be necessary to cut these jumpers.

See page 4-21 for information on setting the magnetic input sensitivity. The setting in effect is indicated by the arrow shown above.

Cat. No. 249, Power Supply Module

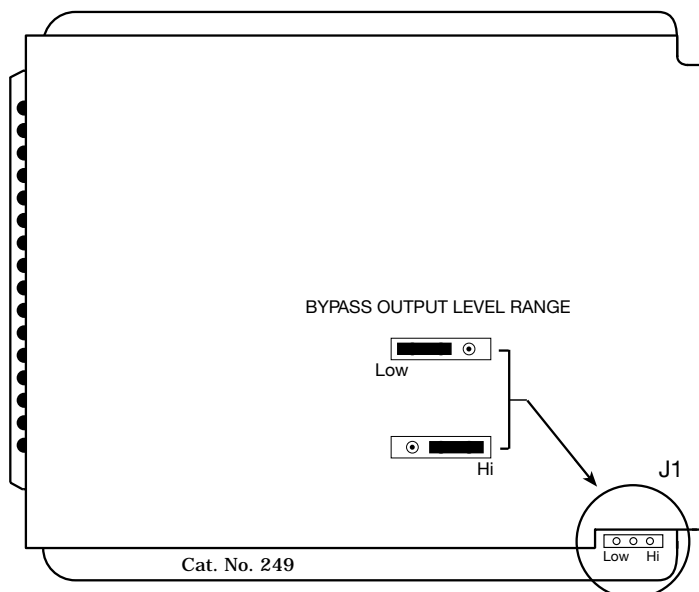

J1 Bypass output level Hi/Low: Set to the Low bypass output range initially. If increased bypass output gain is required, as determined during the bypass gain adjustment later in this manual the jumper should then be placed in the Hi position.

Cat. No. 443, Control Logic Card

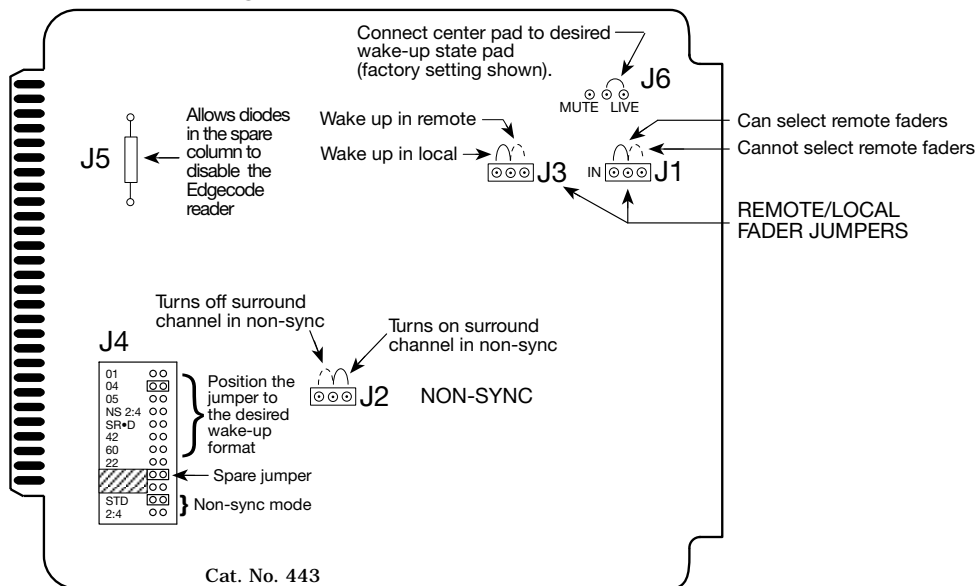

There are four programmable-link jumpers J1-J4 and two hard-wired links J5 and J6.

J1 Remote Fader In/Out:

IN enables fader transfer.
OUT disables the transfer of faders.

Note: If J1 is out and J3 is remote, fader cannot be called back to local.

J2 NS Surr Off/On:

OFF disables surround channels in Non-sync.
ON enables surround channels in Non-sync.

J3 Wake-Up Local/Remote:

LOCAL ensures that the local fader is selected at power on. **REMOTE** selects remote faders at power on.

J4 Wake-Up Format / Non-Sync Processing:

The top 8 positions choose which format will be selected at power-up:

Wake-Up Jumper Position	Format Description
01	Mono
04	Dolby Stereo A-Type
05	Dolby Stereo SR
NS 2:4	Non-sync 2:4 matrix decode
SR*D (10)	Dolby Digital
42	Dolby Stereo 70mm
60	Non-sync
22	35mm mag with surround

The lower two positions determine the processing on the non-sync signal when the front panel non-sync button is pressed:

Non-Sync Mode Jumper Position	Description
Std	Selects standard Non-sync processing. The non-sync signals are sent directly to the left and right screen channels without matrix decoding to maximize stereo width. The optional surround channel is derived via the Cat. No. 150 and selected by J2 with level adjusted on the Cat. No. 441. There is no center or subwoofer output.
2:4	Selects a full 2:4 matrix decode of the non-sync signal. The output is sent to the left, center, right, surround and subwoofer channels without noise reduction. This format could be used in dubbing stages and screening rooms for playback of video and music sources.

J5 Inhibit Cat. No. 384 Output:

JUMPER INSTALLED: Diodes inserted in the spare logic line column (SPR) at the various format positions will disable a Cat. No. 384 edgecode reader when that format is selected and override any codes on the film.

JUMPER NOT INSTALLED: diodes fitted in the spare (SPR) column have no effect on the edgecode reader.

J6 Mute Wake-Up State Live/Mute: **LIVE** sets the fader to the unmuted state at power-up. **MUTE** sets the fader to the muted state at power-up.

CP65 Backplane

J16, J17 J24 Magnetic format headers: In the standard configuration the CP65 is fitted with two channels of A-type noise reduction and therefore does not provide processing for signals entering through the Mag/Aux inputs on TB3 and TB4. Fitting Cat. No. 300 SR/A modules in place of the normal Cat. No. 350 SR modules provides the two additional channels of A-type noise reduction needed for decoding magnetic sound-tracks from 70mm Dolby Stereo (format 42) prints. Link headers J16 and J17 allow signals from the magnetic inputs to be routed through the noise reduction circuitry; link J24 selects whether the noise reduction decoders are switched on when the Mag/Aux format is selected.

Standard CP65 or CP65A

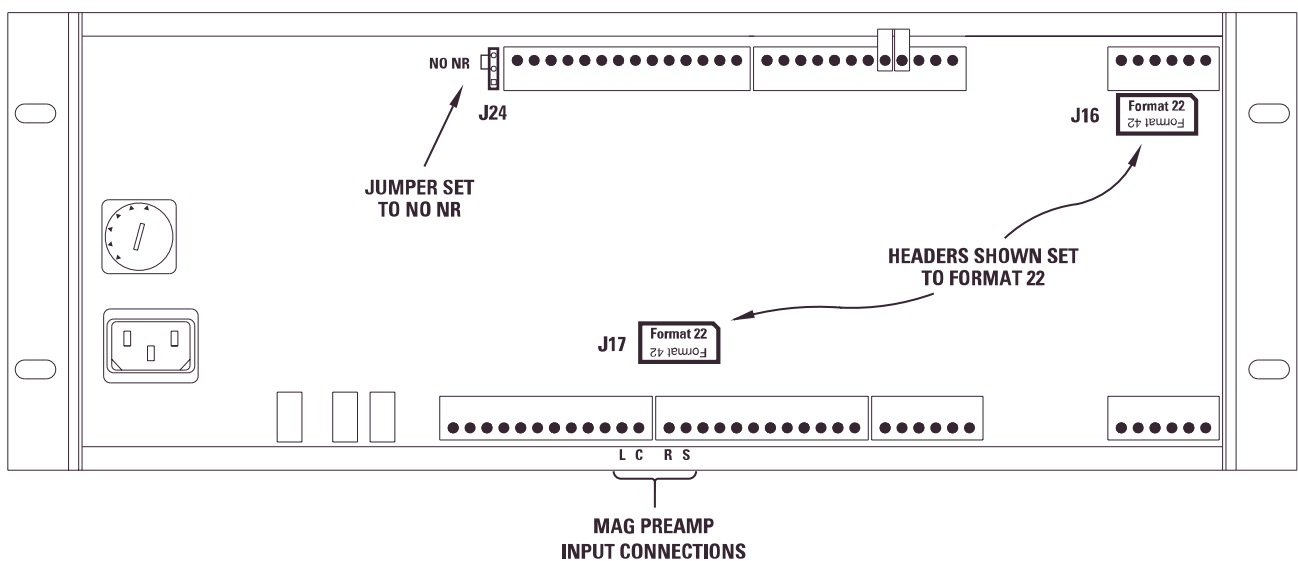

In a standard CP65 (fitted with one Cat. No. 222 and two Cat. No. 350 SR modules) or a CP65-A (fitted with one Cat. No. 222 only) links J16 and J17 should be fitted so that the words **Format 22** appear the right way up. J24 should be fitted in the **NO NR** position.

CP65-300

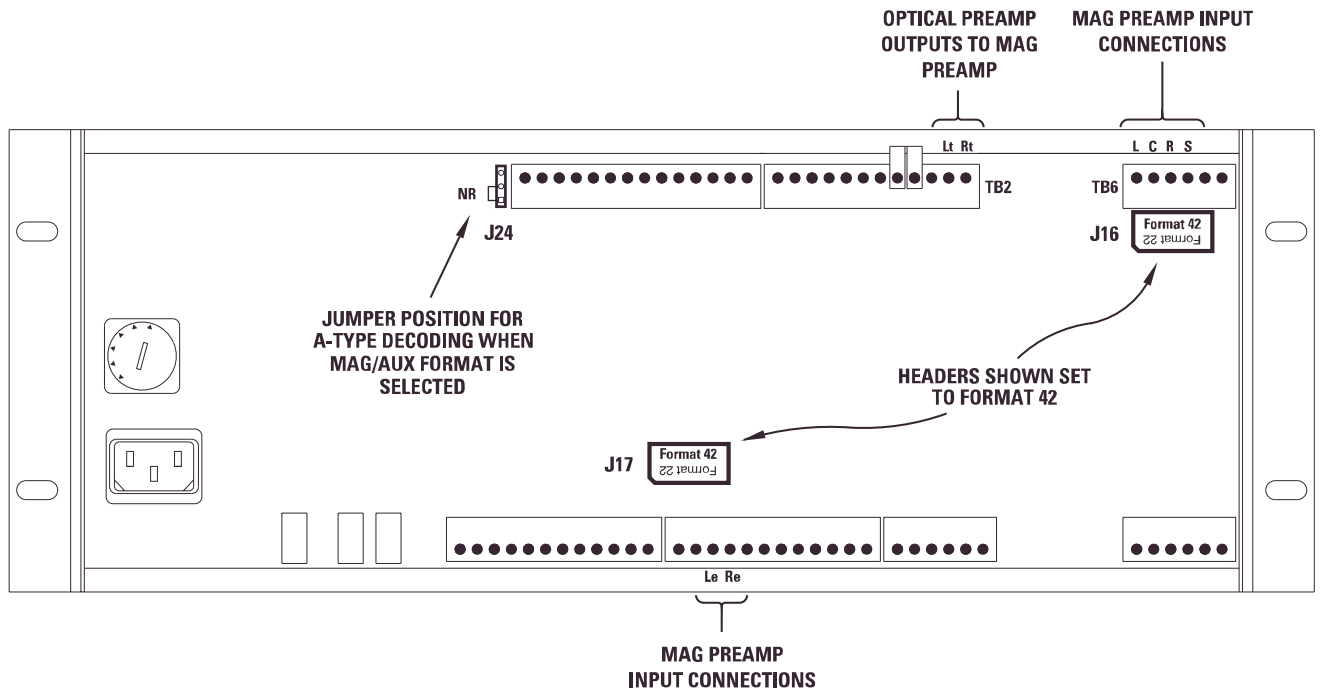

In a CP65-300 (when Cat. No. 300 modules are fitted in place of the normal Cat. No. 350 modules) J16 and J18 should be rotated so that the words "**Format 42**" appears the right way up. With J24 in the "**NR**" position input signals will be A-type decoded when the Mag/Aux format is selected. With J24 in the "**NO NR**" position signals pass through the noise reduction modules but the processing will be turned off. If both of these processing options are required frequently an external switch may be connected to J24.

NOTE: To play 70mm Dolby Stereo (Format 42) with a CP65-300, the left, center, right, and surround outputs of the magnetic pre-amp must be connected to TB6 and the Le and Re outputs must be connected to TB4. If changing between an optical format and mag format 42 is required, external switching may be added (or J16 must be manually rotated to the **Format 22** position for optical playback and to **Format 42** for 70mm playback).

Cat. No. 241 Surround Equalization and Optical Bass Extension. Module (if fitted).

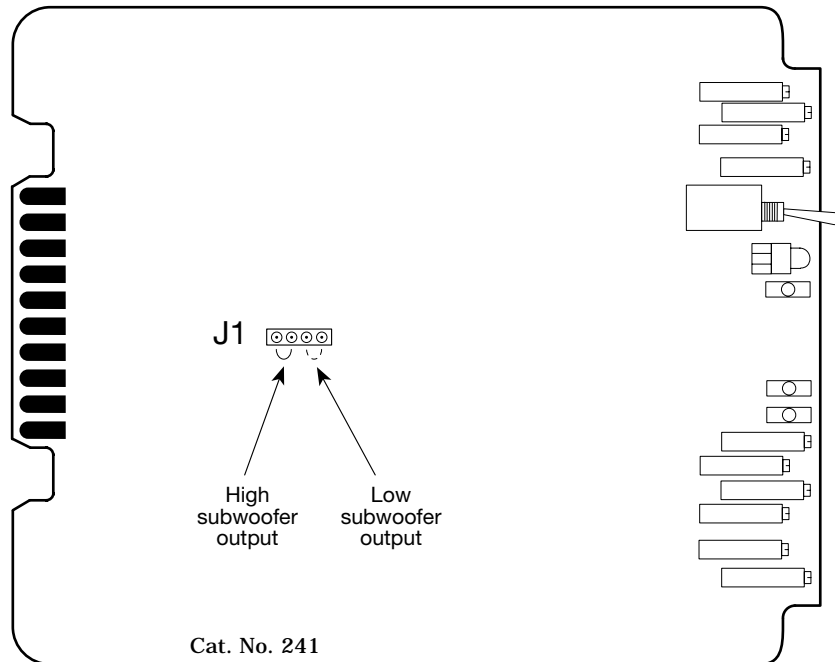

J1 Optical Bass Extension output level: sets the output level range for the subwoofer channel. In the **HIGH** position J1 is set at the factory for a power amplifier input sensitivity of between 90 mV and 1.23 V. If the power amplifiers used in the installation are very sensitive (10 mV to 100 mV input sensitivity), it may be necessary to set J1 to the **LOW** position. If you are unsure of the sensitivity of your power amplifiers set J1 to the **LOW** position initially. If the high output position is required this will be determined during OBE alignment.

STEP 10 If they are not already installed in the CP65 card cage, install all of the cards for your system as shown.

THESE MODULES ARE
NECESSARY FOR BYPASS
OPERATION

★												★	★
Cat. No. 240A (spare)	Cat. No. 240A optical preamp	Cat. No. 350 SR/A Lt (C)	Cat. No. 350 SR/A Rt (S)	Cat. No. 222 2-channel A-type L/R (L,R)	Cat. No. 150 2-4 ch decoder	Cat. No. 64 EQ L	Cat. No. 64 EQ C	Cat. No. 64 EQ R	Cat. No. 441 surround and subwoofer	Cat. No. 242 B chain	Cat. No. 443 control	Cat. No. 249 voltage regulator	Cat. No. 259 transformer module

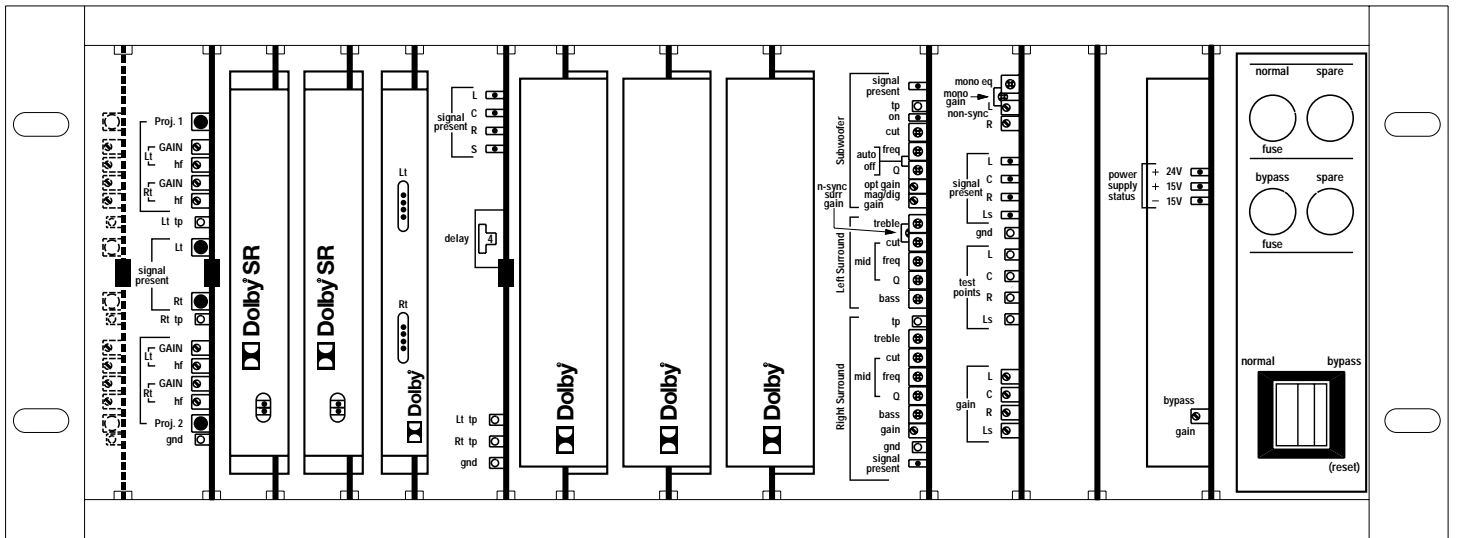

Card Descriptions:

**Slot
No.**

Card

Function

- 1** Slot for spare
Cat. No. 240A Card

Spare location for Cat. No. 240A (or the older Cat. No. 240).
- 2** **Cat. No. 240A**
Optical Preamplifier Card

Amplifies the outputs of the solar cell in the selected projector. Electronic switches select projector No. 1 or 2. The older Cat. No. 240 may also be used.
- 3,4** **Cat. No. 350**
Spectral recording Modules

Each module contains a single channel of Dolby spectral recording (SR) processing for optical soundtracks recorded with Dolby SR (Format 05).

Note:

- 1) Some installations may use two Cat. No. 300 SR/A Processing modules in place of Cat. No. 350.
- 2) In CP65-A, Cat. No. 350/300 are not fitted and the slots are empty.

Slot No.	Card	Function
5	Cat. No. 222 Two-channel Noise Reduction Module	Contains two channels of Dolby A-type noise reduction circuitry with LED indicators to set Dolby Level.
6	Cat. No. 150 2:4 Channel Decoder Card	Derives left, right, center, and surround information from the two optical tracks on the film.
7,8,9	Cat. No. 64B Equalizer Module	Contains treble and bass controls and 27 third-octave equalizer controls. One card is used for each front channel: left, center, right.
10	Cat No. 441 Surround Equalizer, Subwoofer card.	<p>(1) Provides equalization for the surround channels.</p> <p>(2) Extracts low frequency information from the L, C, and R signals and sends this signal to a subwoofer output through an equalizer and a fader circuit.</p> <p>(3) Provides Subwoofer input for magnetic and digital soundtracks and Stereo Surround from a Dolby Digital adapter.</p> <p>Note: Cat. No. 241 may also be used in this position but does not provide (3) above.</p>
11	Cat. No. 242 B-Chain Card	Contains the signal processing circuitry for the B-Chain except for the equalizers. Has input buffers and filters for non-sync, aux and magnetic sources, electronic switches to select input sources, a 4-channel fader circuit, and output level potentiometers for L,C,R,S.
12	Cat. No. 443 Control Logic Card	Configures the CP65 for the selected format. Also contains fader mute and fader local/remote status circuits. Generates control logic signals for other cards in the CP65. Its inputs are the Cat. No. 447 front panel controls, external remote boxes, or automation inputs to the CP65. It also contains a jumper block to enable the wake-up condition to be preselected.

Slot No.	Card	Function
13	Cat. No. 249 Power Supply Module	Contains a semi-regulated power supply with nominal outputs of +15V, -15V, and 24V. Also contains the bypass amplifier, gain trimmer, and a +12V bypass power supply.
14	Cat. No. 259 Transformer Module	Contains two power transformers (main and bypass) that convert mains voltage AC to low-voltage AC. The selector switch for main voltages is accessible through the backplane. It permits a choice of the following nominal mains voltages: 100, 120, 140, 200, 220, and 240V.

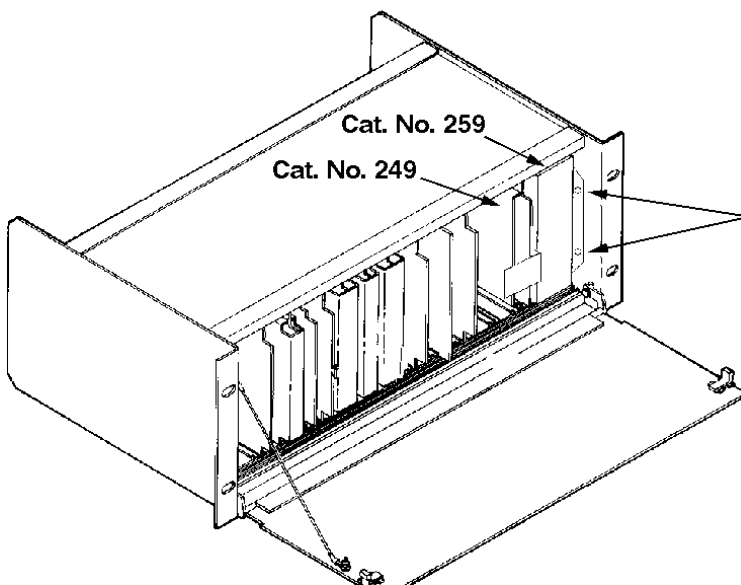

As a safety feature in many countries, the Cat. No. 249 module is held in place by a retainer bracket mounted to the Cat. No. 259 module. To withdraw the Cat. No. 249 it is first necessary to remove the Cat. No. 259. Do this by disconnecting the power cord from the Cat. No. 259 and then removing the two screws indicated by arrows. Remove the Cat. No. 259 followed by the Cat. No. 249.

ADDITIONAL INFORMATION FOR THE SAFE OPERATION OF THE CP65

To ensure proper operation and guard against potential shock hazard, the CP65 must be connected only to a properly wired, grounded (earthed) mains receptacle. If you are uncertain about the wiring of your mains outlet do not use it. Consult a qualified electrician. The power cord is supplied with either a standard U.S.A. three-prong plug or with unterminated leads for use in other countries. The wires are colored in accordance with the following international code:

	<u>International</u>	<u>U.S.</u>
live or hot	brown	black
neutral	blue	white
earth	green/yellow	green/yellow

Before the power cord is connected to the CP65, ensure that a qualified electrician has wired the cord following the code.

U.S. Style Plugs

The ground terminal of the plug is connected directly to the chassis of the unit. For continued protection against electric shock, a three-pin power receptacle MUST be used, and the ground wire MUST always be connected. DO NOT use a ground-lifting adaptor and NEVER cut the ground pin on a three-prong plug.

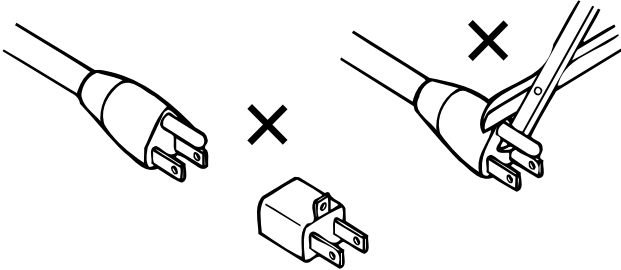

Connections for United Kingdom

WARNING: THIS APPARATUS MUST BE EARTHED.

As the colours of the cores in the mains lead may not correspond with the coloured markings identifying the terminals in your plug, proceed as follows:

- the core which is coloured green and yellow must be connected to the terminal in the plug which is marked with the letter E or by the earth symbol \perp , or coloured green or green and yellow.
- the core which is coloured blue must be connected to the terminal which is marked with the letter N or coloured black.
- the core which is coloured brown must be connected to the terminal which is marked with the letter L or coloured red.

WARNING—Before you connect the unit to mains power, check that it has been set to the correct mains voltage and that the correct fuse is installed. To reduce the risk of fire, replace the fuse only with the same type and 250V rating:

Voltage Setting	Fuse	Type
100/120/140 VAC	1.25 A	1/4" x 1-1/4" slow-blow
200/220/240 VAC	T 630 mA	5 x 20mm time lag.

IEC NOTICES

IMPORTANT SAFETY NOTICE

This unit complies with the safety standard IEC65. To ensure safe operation and to guard against potential shock hazard or risk of fire, the following **must** be observed:

- If the unit has a **voltage selector**, ensure that it is set to the correct mains voltage for your **supply**. If there is no voltage selector, ensure that your supply is in the correct range for the input requirement of the unit.
- Ensure **fuses** fitted are the **correct rating and type** as marked on the unit.
- The unit **must be earthed** by connecting to a correctly wired and **earthed** power outlet.
- The **power cord** supplied with this unit must be wired as follows:

Live—Brown Neutral—Blue Earth—Green/Yellow

GB

IMPORTANT - NOTE DE SECURITE

Ce materiel est conforme à la norme IEC65. Pour vous assurer d'un fonctionnement sans danger et de prévenir tout choc électrique ou tout risque d'incendie, veuillez à observer les recommandations suivantes.

- Le selecteur de tension doit être placé sur la valeur correspondante à votre alimentation réseau.
- Les fusibles doivent correspondre à la valeur indiquée sur le materiel.
- Le materiel doit être correctement relié à la terre.
- Le cordon secteur livré avec le materiel doit être câblé de la manière suivante:

Phase—Brun Neutre—Bleu Terre—Vert/Jaune

F

WICHTIGER SICHERHEITSHINWEIS

Dieses Gerät entspricht der Sicherheitsnorm IEC65. Für das sichere Funktionieren des Gerätes und zur Unfallverhütung (elektrischer Schlag, Feuer) sind die folgenden Regeln unbedingt einzuhalten:

- Der Spannungswähler muß auf Ihre Netzspannung eingestellt sein.
- Die Sicherungen müssen in Type und Stromwert mit den Angaben auf dem Gerät übereinstimmen.
- Die Erdung des Gerätes muß über eine geerdete Steckdose gewährleistet sein.
- Das mitgelieferte Netzkabel muß wie folgt verdrahtet werden:

Phase—braun Nulleiter—blau Erde—grün/gelb

D

NORME DI SICUREZZA - IMPORTANTE

Questa apparecchiatura è stata costruita in accordo alle norme di sicurezza IEC 65. Per una perfetta sicurezza ed al fine di evitare eventuali rischi di scossa elettrica o d'incendio vanno osservate le seguenti misure di sicurezza:

- Assicurarsi che il selettore di cambio tensione sia posizionato sul valore corretto.
- Assicurarsi che la portata ed il tipo di fusibili siano quelli prescritti dalla casa costruttrice.
- L'apparecchiatura deve avere un collegamento di messa a terra ben eseguito; anche la connessione rete deve avere un collegamento a terra.
- Il cavo di alimentazione a corredo dell'apparecchiatura deve essere collegato come segue:

Filo tensione—Marrone Neutro—Blu Massa—Verde/Giallo

I

AVISO IMPORTANTE DE SEGURIDAD

Esta unidad cumple con la norma de seguridad IEC65. Para asegurarse un funcionamiento seguro y prevenir cualquier posible peligro de descarga o riesgo de incendio, se han de observar las siguientes precauciones:

- Asegúrese que el selector de tensión esté ajustado a la tensión correcta para su alimentación.
- Asegúrese que los fusibles colocados son del tipo y valor correctos, tal como se marca en la unidad.
- La unidad debe ser puesta a tierra, conectándola a un conector de red correctamente cableado y puesto a tierra.
- El cable de red suministrado con esta unidad, debe ser cableado como sigue:

Vivo—Marrón Neutro—Azul Tierra—Verde/Amarillo

E

VIKTIGA SÄKERHETSÅTGÄRDER!

Denna enhet uppfyller säkerhetsstandard IEC65. För att garantera säkerheten och gardera mot eventuell elchock eller brandrisk, måste följande observeras:

- Kontrollera att spänningsväljaren är inställd på korrekt nätspänning.
- Kontrollera att säkringarna är av rätt typ och för rätt strömstyrka så som anvisningarna på enheten föreskriver
- Enheten måste vara jordad genom anslutning till ett korrekt kopplat och jordat el-uttag.
- El-sladden som medföljer denna enhet måste kopplas enligt följande:

Fas—Brun Neutral—Blå Jord—Grön/Gul

S

BELANGRIJK VEILIGHEIDS-VOORSCHRIFT:

Deze unit voldoet aan de IEC65 veiligheids-standaards. Voor een veilig gebruik en om het gevaar van elektrische schokken en het risico van brand te vermijden, dienen de volgende regels in acht te worden genomen:

- Controleer of de spanningscarroussel op het juiste Voltage staat.
- Gebruik alleen zekeringen van de aangegeven typen en waarden.
- Aansluiting van de unit alleen aan een geaarde wandcontactdoos.
- De netkabel die met de unit wordt geleverd, moet als volgt worden aangesloten:

Fase—Bruin Nul—Blauw Aarde—Groen/Geel

NL

- STEP 11** Turn the front pannel **FADER** fully down, then connect the CP65 to mains power.

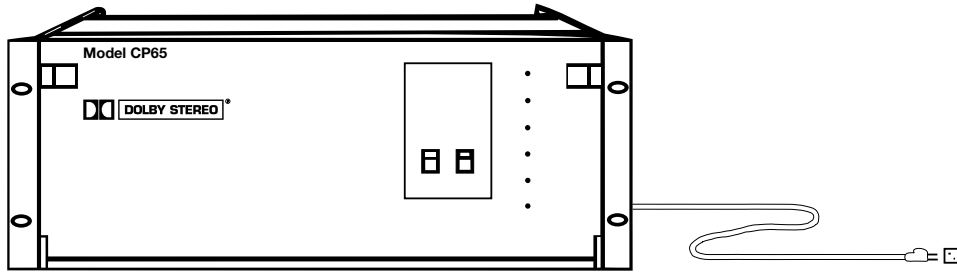

- STEP 12** With the **NORMAL/BYPASS** switch (accessible with the front door open) in the **NORMAL** position, verify that all three LEDs on the Cat. No. 249 Power Supply Module are lit. Close the front door and verify that format 04 Dolby stereo optical with surround, local active, and proj 1 or proj 2 LEDs are on (unless a different wake-up format was selected on the Cat. No. 443).
- STEP 13** Select each format in turn, using the buttons on the front panel and check that the associated LED lights.
- STEP 14** Press the **MUTE** pushbutton switch; the LED on the switch should blink. Press the **MUTE** pushbutton switch again; the LED on the switch should be off.
- STEP 15** Set the **NORMAL/BYPASS** switch to the **BYPASS** position. The **bypass** LED on the front panel should blink and all other LEDs should be off.
- STEP 16** Return the **NORMAL/BYPASS** switch back to the **NORMAL** position and apply power to the other projection room equipment.

HUM PROBLEMS

If you hear undesirable hum from the speakers when you apply power to the CP65 and other projection room equipment, check the following list for possible causes:

- 1. Ground loops** caused by audio signal wiring, especially to power amplifiers. Only one end of an audio shield wire should be connected. See Pages 2-3 and 2-4. Be sure to check the booth monitor installation.

The CP65 backplane contains a link which connects frame ground to signal/power ground (TB2 terminals 8 and 9). If you have checked items 1 through 7 and hum is still present, removing this link may fix the problem.

- 2. Projector power wiring.** All mains wiring should be properly grounded.
- 3. Room lighting dimmer controls (SCR-TYPE).**

- 4. Power amplifiers.** Disconnect from the CP65 and ground the inputs to determine if the power amplifiers are causing hum problems.

With CP65 **FADER** turned up and format 04 selected:

- 5. Solar cell wiring.** Check the shield connections. Cell wiring should be placed away from mains and other wiring.
- 6. Exciter lamp power supply.** Check for ripple on the DC power supply outputs. Some old exciter lamp power supplies and emergency supplies provide AC to the lamp. The resulting hum makes them totally unsuitable for a stereo playback system. Such exciter supplies should be replaced.
- 7. Projection room lighting/solar cells.** Ambient lighting, especially florescent tubes, can leak into the solar cell area and cause hum.

SECTION 3

AN OVERVIEW OF THE ALIGNMENT PROCEDURE

This section is an overview of the general principles involved in the alignment of Dolby cinema equipment. It is useful to develop an understanding of why the CP65 is aligned as described in this manual. If the installer is already familiar with these principles, or is in a hurry to complete the installation, this section may be read later. Continue the installation procedure beginning with Section 4.

1. Aligning the A-Chain

The A-Chain is first calibrated by use of the Cat. No. 69 Dolby Tone test film to establish the correct Dolby operating level within the CP65 and to ensure correct tracking of the Dolby noise reduction circuit.

Pink noise is used for equalization of the A-chain. (Pink noise is similar to white noise but provides equal energy per octave of bandwidth.) Pink noise for A-chain alignment is recorded on the other side of the Cat. No. 69 test film. The output should be displayed on a Real Time Analyzer (RTA) so adjustments can be made quickly.

The optical slit is the key element in the A-chain because it imposes the initial limitation on the high-frequency response of the system. Light from the exciter lamp passes through the optical slit and is focussed on the optical soundtracks on the film. The light that passes through the soundtracks falls on the stereo solar cell which generates an electrical signal that is proportional to the audio signal recorded on the optical soundtracks. The slit introduces high frequency loss which must be compensated by circuitry in the Cat. No. 240A optical preamplifier (see Appendix B).

The slit image must be correctly focussed on the film and must be precisely at right angles to the direction of film movement in order to maintain the correct phase relationships between the two optical tracks. Any azimuth error will show as a loss of high frequency in the front channels and potentially excessive crosstalk in the surround channels.

Each channel in the Cat. No. 240A optical preamplifier is equipped with a slit loss equalizer control. Adjustment of this control shifts a fixed amount of boost upward or downward in frequency, but the shape of the curve remains constant. A perfectly flat response up to a minimum of 12 kHz can be achieved possible. See Appendix B for further details.

2. Aligning the B-Chain

In most theatre playback systems, the acoustical qualities of the theatre are difficult to change. Therefore, the primary area where improvement is possible is correcting loudspeaker response errors caused by the theatre acoustic environment.

It is not practical for the entire cinema industry to standardize on a single make and model of loudspeaker. In any event, the different acoustical characteristics of individual theatres would, to some extent, negate any such standardized speakers. Electronic equalization of each loudspeaker system achieves consistent results in a broad spectrum of environments,

and with a broad range of speakers. Accurate equalization requires the use of standardized acoustic measurement procedures.

A pink noise generator provides a continuous random noise signal that covers the total bandwidth and is used to measure and adjust the response of the loudspeakers. The use of random noise eliminates the problems inherent with tones (standing wave patterns in the theatres) and enables the frequency response of the entire system to be observed. Each channel can be measured and adjusted independently of the other channels.

A calibrated microphone is placed in the auditorium to receive the pink noise reproduced by the loudspeaker; the output of the microphone is fed to a real time analyzer (RTA). The RTA displays the complete audio spectrum received by the microphone in the form of a frequency response curve. Pure pink noise would yield a "flat" horizontal line on the RTA. Thus, the effect of adjustments to the equalizers is quickly and easily seen.

One of the problems inherent in equalization is the nature of the environment. In an open space, a perfect loudspeaker, radiating a perfectly flat response in all directions, placed in front of a perfectly flat microphone, producing perfectly flat response to sounds arriving from all directions, will produce a perfectly flat response on the RTA from pink noise. In an enclosed space such as a theatre, the results are different. When the pink noise generator is first turned on, all of the sound that initially reaches the microphone comes directly from the loudspeaker; the response is flat—for a few milliseconds. Then reflected sound from the walls, ceiling, floor, seats, etc. starts to arrive at the microphone together with the direct sound from the loudspeaker. This indirect or reflected sound reinforces the direct sound. The system soon settles into an equilibrium condition. As much energy is being absorbed at the walls, ceiling, etc. as is fed into the room. Since high and mid frequency energy is absorbed when sound is reflected, the displayed response appears to have a rising bass and a falling treble characteristic. At first glance, rolling off the bass and boosting the high frequencies may appear to be the logical approach for a flat steady-state response, but such an arrangement works only on sustained sounds. Dialogue contains short, impulsive sounds and will yield a much-too-bright result because there is no time for reverberation to build and add to the original sound. What is required is a curve that favors such impulsive "first arrival" sound and implies the same gently falling response that is observed when the output of an ideal loudspeaker is measured with a perfect microphone in the theatre.

The amount of reverberation varies with frequency and the higher the frequency the more the treble will be absorbed rather than being reflected. A typical reverberation curve in a theatre rolls off at about 3 dB per octave above 2 kHz. This characteristic is used to define the standard steady-state response curve for all dubbing theatres in which Dolby stereo films are mixed and for all Dolby stereo-equipped cinemas.

The size of the theatre affects the reverberation time and, therefore, the measurement of frequency response. After alignment to this standard curve, some slight adjustment of high frequency slope may be found necessary for extremely large or small theatres. The treble control on the Cat. No. 64 Equalizer card can be adjusted to reduce the output on the response curve by approximately 1 dB at 8 kHz for very large theatres; an increase of 1 dB at 8 kHz may be in order for a very small theatre. Any such adjustment should be based on an evaluation by ear of actual known films rather than as a rule of thumb.

Many loudspeakers used in theatres are far from ideal and require boosting of the low- and high-frequency extremes in order to produce an approximation of the standard reference response curve. Bass and treble controls—centered on the turnover points of typical loudspeakers—lift the ends of the spectrum without the need for large amounts of narrow-band boost from the third-octave controls in the Cat. No. 64 cards. The third-octave controls are used for minor adjustments that are required to smooth the frequency response curve.

The final factor is masking of the screen. Most stereo films today are shown in a wide-screen format. The masking curtains of the screen must be drawn back sufficiently to clear the left and right speakers before any adjustments or measurements are made. The treble horns should clear the screen frame and be mounted as close as possible to the screen. Conventional black felt side masking can severely curtail high frequency response. Consequently, there would be severe losses if the left and right loudspeakers were equalized with the masking open as for a 2.35:1 film, and then the masking were brought in for a 1.85:1 film, thus obscuring the outer speakers. To avoid this problem, some theatres have installed acoustically transparent masking cloth, and others leave the masking open whenever they are showing a 1.85:1 film with a stereo soundtrack. Moving the speakers towards the center of the screen so as to clear heavy masking is not a good solution, since the stereo sound width would be degraded.

Repainted screens cannot be used for quality sound playback, since the perforations which allow the high frequencies through the screen become clogged with paint.

SECTION 4

A-CHAIN ALIGNMENT

The A-chain is the part of the sound system that covers the film path, solar cell, optical preamplifier, slit loss equalizer and Dolby noise reduction circuit.

The CP65 does not contain a magnetic A-chain but has facilities for switching external magnetic preamplifiers into the B-chain. An overview of external magnetic A-chain adjustments is given at the end of this section.

A-Chain Alignment Procedures

a. Preliminary Procedures

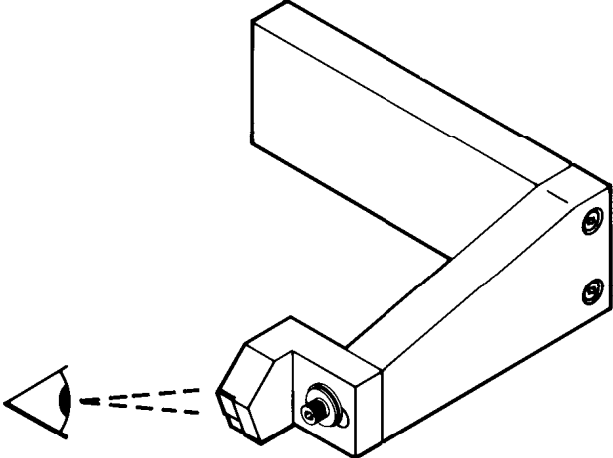
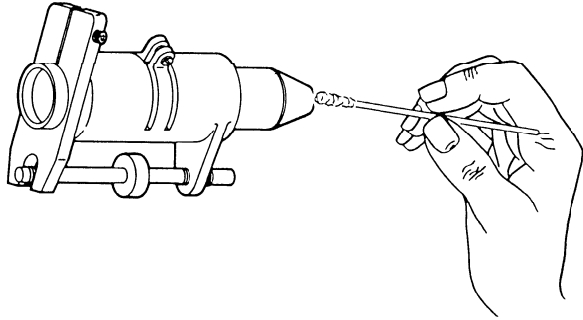
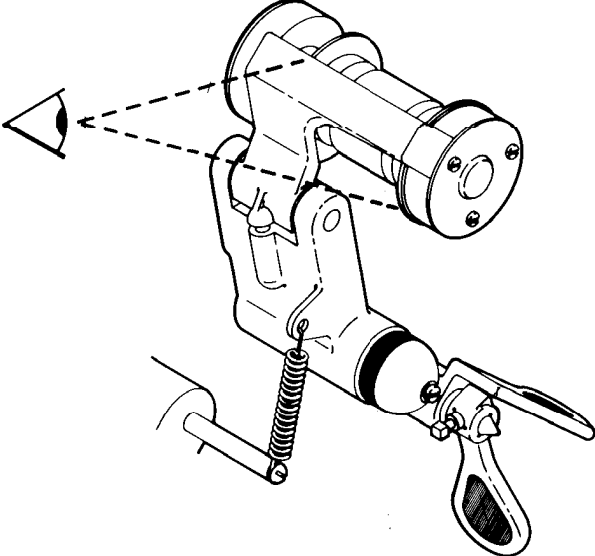
Step No.	Action	Indication
1		
2		
3		

A-Chain Alignment Procedures

a. Preliminary Procedures

Notes
<p>If a stereo solar cell is already installed on Projector No. 1, inspect the surface of the cell for cracks, chipping, or other damage. If the cell appears to require replacement, remove the mounting bracket from the projector and replace the cell and mounting block assembly. If the cell appears to be usable, either loosen the cell mounting bracket and swing the cell out of the light path or, if this cannot be done, remove the mounting bracket and cell mounting block assembly from the projector and set aside.</p>
<p>Clean the lens surfaces with a cotton swab moistened with lens cleaner. But keep in mind that you may find in Step 14 under "b. Optical Preamplifier Adjustment" that it will be necessary to remove and inspect the lens if the high-frequency response is not correct.</p> <p>If the lens is removed, clean the lens as indicated above and look through the lens at a bright light. Repeated alternate heating and cooling of the lens can cause oil or other contaminants to enter the lens barrel. Verify that there is a clear, unobstructed light path through the lens and that the edges of the slit are sharp without cracks or corrosion. Fit a new lens assembly if you are unable to clear the optical path through the slit.</p>
<p>Inspect the lateral film guides for evidence of cuts, cracks, surface defects, and any foreign materials that could impair the film guiding. Clean as required or replace the guides, as necessary. Make sure the guide roller rotates freely and, if it is spring mounted, make sure that lateral movement and return is not obstructed. If the roller has a felt or rubber insert, check for a flat spot, replace the roller if need be.</p>

A-Chain Alignment Procedures

a. Preliminary Procedures

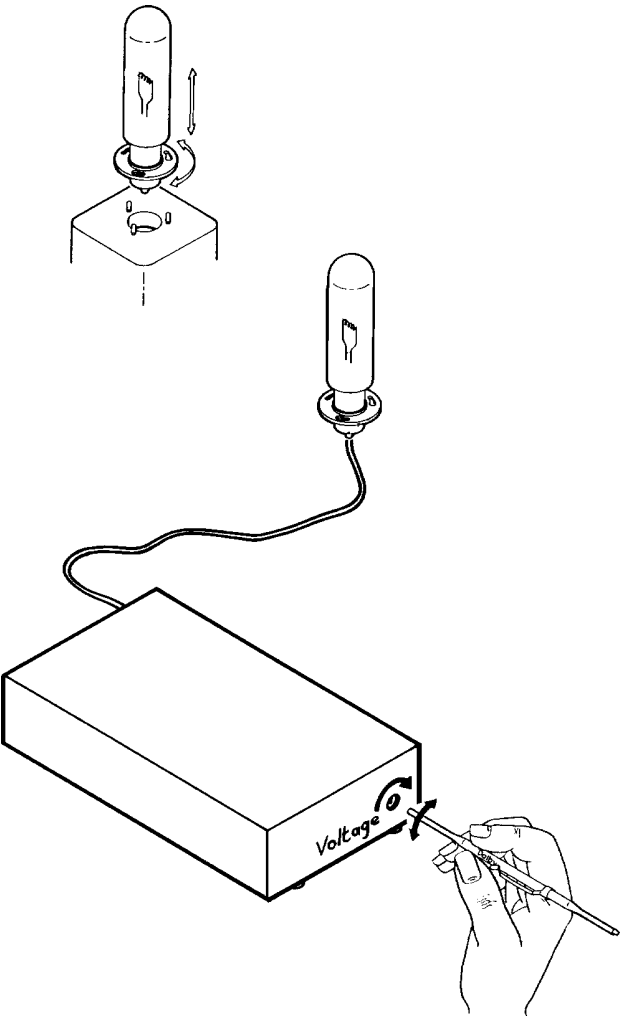
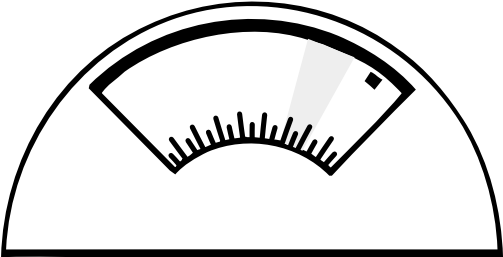
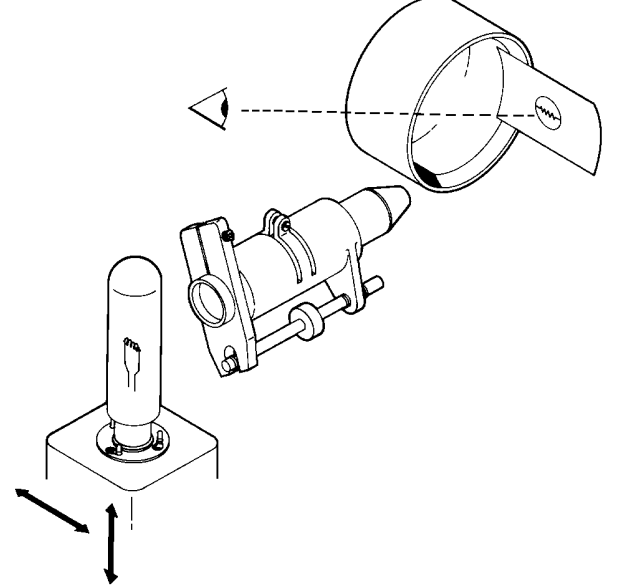
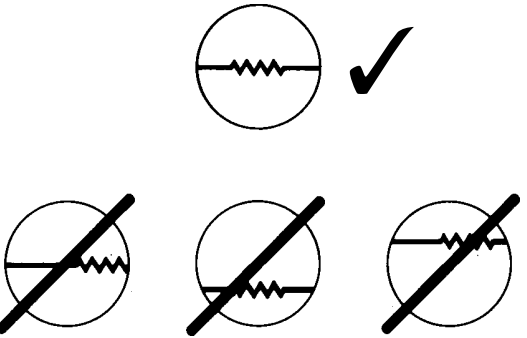
Step No.	Action	Indication
4		<p style="text-align: center;">70 TO 80% OF RATED VOLTAGE</p> 
5		

A-Chain Alignment Procedures

a. Preliminary Procedures

Notes						
<p>Remove the existing exciter lamp and replace with a new lamp.</p>						
<p>Adjust the exciter lamp DC voltage to 70% to 85% of the rated voltage and verify that there is no more than 3% ripple present with the lamp on, using an AC millivolt meter or oscilloscope. Do NOT attempt to extend the exciter lamp life by running at too low a voltage; the center of the slit may receive higher illumination than the edges, causing signal distortion.</p>						
<table border="0"> <thead> <tr> <th style="text-align: center;">LAMP VOLTAGE</th> <th style="text-align: center;">DC ADJUSTMENT</th> </tr> </thead> <tbody> <tr> <td style="text-align: center;">6 V</td> <td style="text-align: center;">4-5 volts</td> </tr> <tr> <td style="text-align: center;">9 V</td> <td style="text-align: center;">6.5-8 volts</td> </tr> </tbody> </table>	LAMP VOLTAGE	DC ADJUSTMENT	6 V	4-5 volts	9 V	6.5-8 volts
LAMP VOLTAGE	DC ADJUSTMENT					
6 V	4-5 volts					
9 V	6.5-8 volts					
<p>If the projector uses a plastic light pipe or tube, verify that the light output is not appreciably affected by dirt, cracks or flaws, yellowing, or foreign matter. Replace if necessary.</p>						
<p>Place a white card at a point behind the film plane. Then adjust the position of the exciter lamp until the image of the filament is centered both vertically and horizontally as shown.</p>						
<p>You may find that obtaining an image of the filament is difficult in some projectors. Place a piece of tissue paper over the lens to assist in seeing the image of the filament. Some projectors do not use adjusting screws to change the position of the lamp; shims are sometimes used for positioning.</p>						

A-Chain Alignment Procedures

b. Optical Preamp Adjustments

Step No.	Action	Indication
1		
2		
3		

A-Chain Alignment Procedures

b. Optical Preamp Adjustments

Notes
<p>Loosely install the stereo solar cell bracket on the projector. Position the bracket carefully until the surface of the cell is 1 mm from the film plane surface. Note that if this distance is exceeded, there will be crosstalk between the two optical stereo tracks. Check the image of the slit on the cell. The image should be a thin sharp line. The slit image should be as long as the cell, and positioned three-quarters of the way up the cell. Try to get the best compromise among all of these conditions and then tighten the cell bracket mounting screws.</p>
<p>Connect the cells to the correct CP65 input terminals via the terminal block, using a single "twisted pairs" shielded (screened) 4-conductor cable or two shielded 2-conductor cables. Connect the inner conductors to the projector input + and - terminals exactly as shown. Connect the shields only at the CP65 end. Note that the cell associated with the right channel is closest to the edge of the film.</p>
<p>Separate cells are used for each channel in reverse scan projectors. Both use identical red (high) and black (low) wires. A check will be made in Step 9 to determine the correct left and right placement.</p>
<p>On the Cat. No. 240A Optical Preamp Card</p>
<p>Turn all of the Proj 1 and Proj 2 gain potentiometers fully clockwise (CW).</p>

A-Chain Alignment Procedures

b. Optical Preamplifier Adjustments

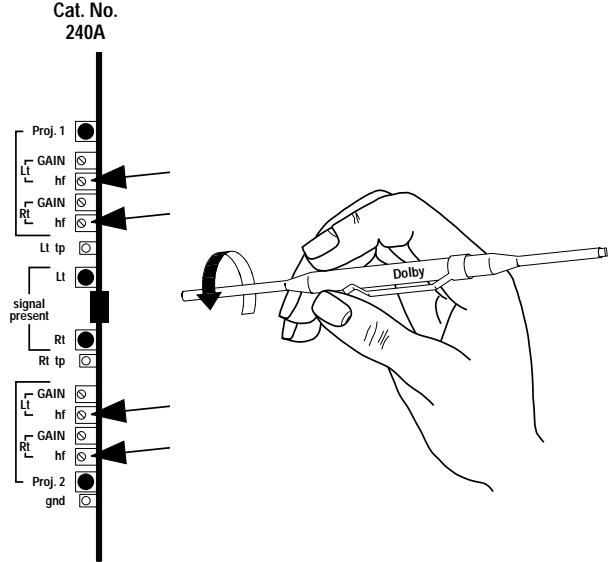
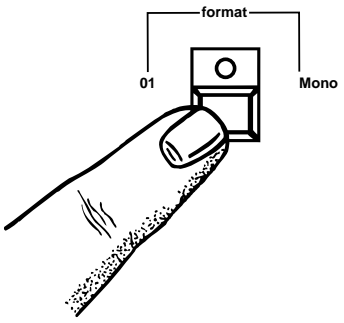
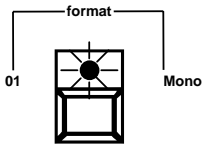
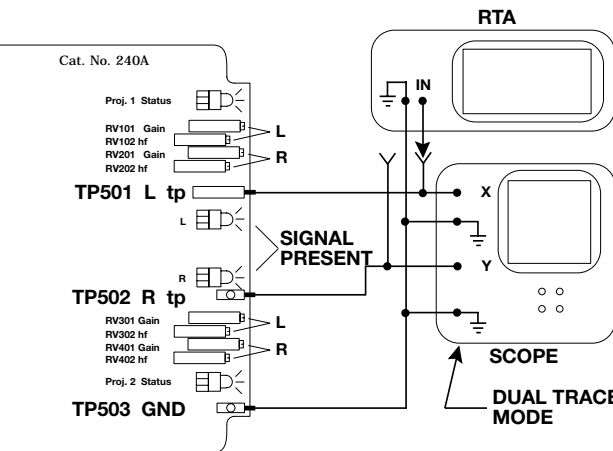
Step No.	Action	Indication
4	<p>Cat. No. 240A</p> 	
5		
6	 <p>NOTE: Be sure that the vertical range is set the same on both channels.</p>	

A-Chain Alignment Procedures

b. Optical Preamplifier Adjustments

Notes
<p>On the Cat. No. 240A Optical Preamplifier Card</p> <p>Turn all of the Proj 1 and Proj 2 hf potentiometers fully counterclockwise (CCW).</p> <p>Verify that power to the power amplifiers is OFF.</p>
<p>Press the Mono 01 format switch on the front panel; the LED in the switch should light.</p>
<p>Connect the RTA and the oscilloscope to the Cat. No. 240A TP501 L (left) and TP502 R (right) test points as shown in the interconnection diagram. Switch the scope to dual trace mode.</p> <p>Earth (ground) both instruments at TP503 GND on the card.</p> <p>The input to the RTA will be switched to the left channel or right channel in the following steps.</p>

A-Chain Alignment Procedures

b. Optical Preamp Adjustments

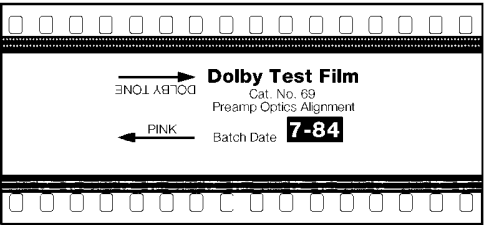
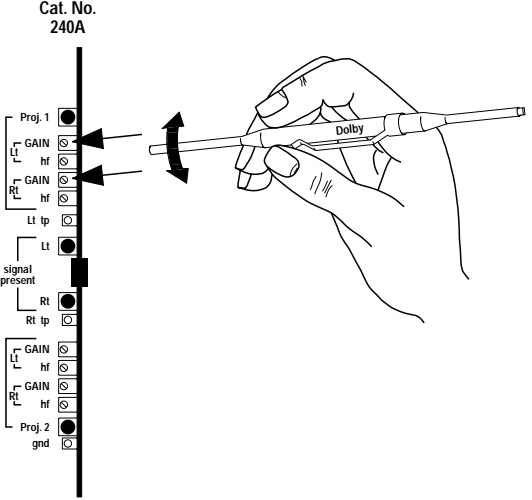
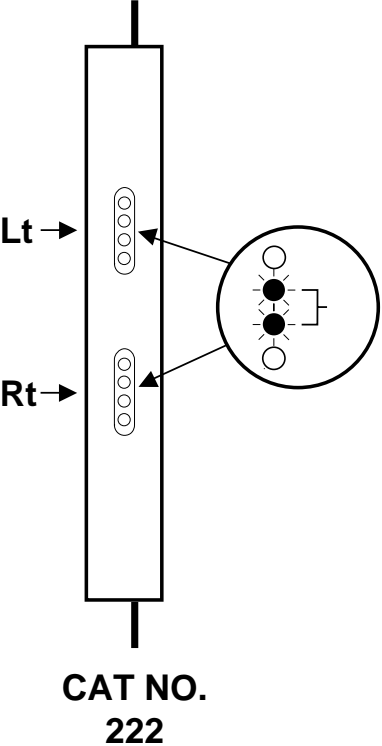
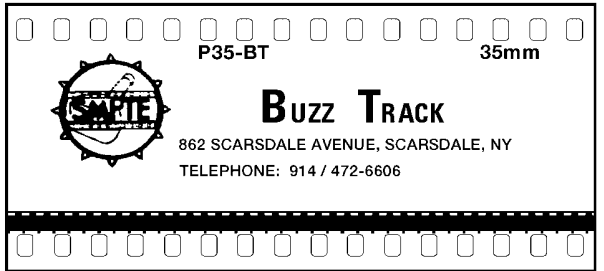
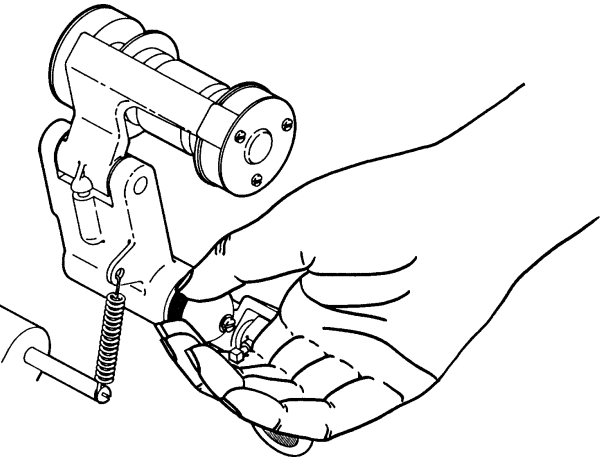
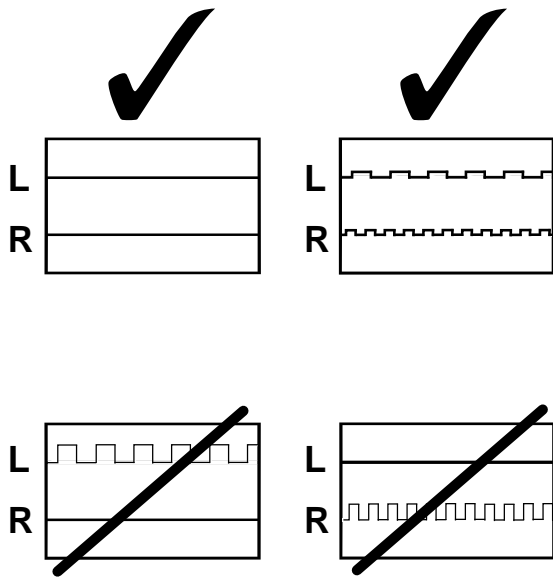
Step No.	Action	Indication
7	<p>Dolby Tone</p>  <p>Pink Noise</p> <p>Cat. No. 240A</p> 	 <p>CAT NO. 222</p>
8	 <p>Buzz Track</p> <p>862 SCARSDALE AVENUE, SCARSDALE, NY TELEPHONE: 914 / 472-6606</p> 	 <p>OSCILLOSCOPE TRACES</p>

A-Chain Alignment Procedures

b. Optical Preamp Adjustments

Notes
<p>Thread and play the Dolby tone side of the Cat. No. 69 test film for an initial test of the signal path through the projector preamplifier. The film emulsion should face away from the screen. Adjust the Cat. No. 240A Proj 1 L and R gain potentiometers until the LEDs on the Cat. No. 222 Dual Noise Reduction Module indicate the Dolby level — the center two green LEDs are lit. In addition, verify that the signal present LEDs on the Cat. No. 240A are lit. The Dolby tone signal should be visible on the oscilloscope.</p>
<p>Remove the Cat. No. 69 test film and thread the SMPTE Buzz Track Film. This film has modulation just beyond the normally scanned areas of the optical sound tracks. The objective of this test is to ensure that the slit illuminates only the sound-tracks. Depending on the design of the projector, the positioning of the slit relative to the optical tracks is adjusted as follows:</p>
<p>The film guide is adjusted laterally for a null if the lens and exciter lamp are fixed in position;</p>
<p>The lens and exciter lamp assembly are adjusted laterally for a null if the film cannot be moved laterally.</p>
<p>The adjustment is correct when there is no signal output while the film is played. It may not be possible to adjust for a null with some older slits; in such instances, adjust for a minimum and equal signal on L and R.</p>
<p>Some projectors use a lens with an adjustable slit width. The adjustment is correct at the point when the left and right signals both disappear equally.</p>

A-Chain Alignment Procedures

b. Optical Pre-amplifier Adjustments

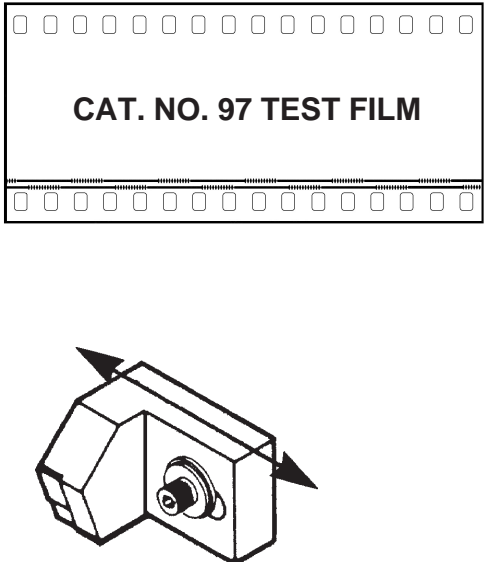
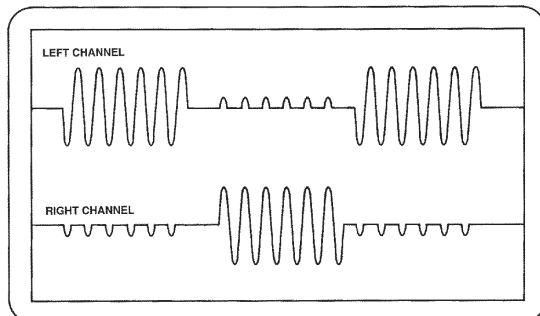
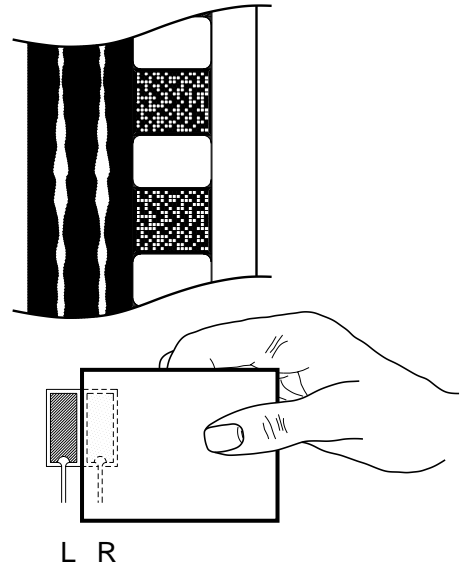
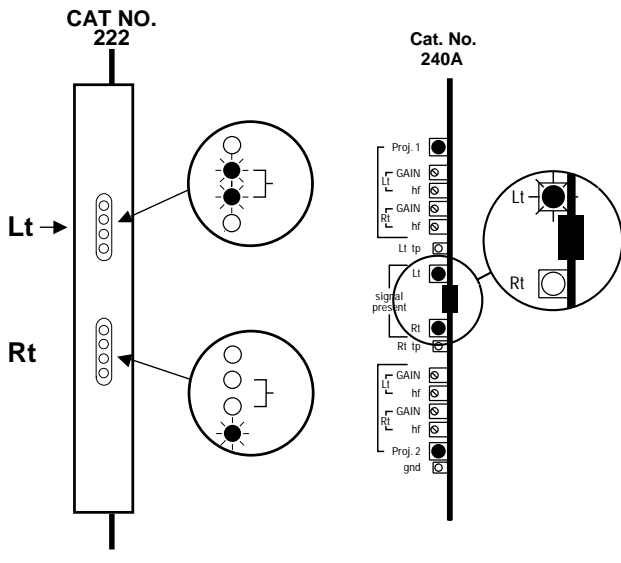
Step No.	Action	Indicationn
9	<p>Left-Right</p> 	 <p>OSCILLOSCOPE TRACE</p>
10		
11	<p>REPEAT 8 AND 9</p>	

A-Chain Alignment Procedures

b. Optical Pre-amplifier Adjustments

Notes
<p>Remove the SMPTE Buzz Track Film and thread and play the Cat. No. 97 Stereo Cell Alignment Film. While the film is playing, look at the oscilloscope. If a large amount of crosstalk is present, loosen the stereo solar cell head and move the head from side to side until the crosstalk both left-to-right and right-to-left are both at a minimum and are equal. (The right channel is the track toward the outside of the projector.) You should be able to adjust the position of the cell to obtain better than 20 dB of crosstalk rejection (10:1 voltage ratio) both left-to-right and right-to-left. Setting the gain of both channels of the preamplifier to a known setting such as minimum or maximum gain will assist in judging when the crosstalk is equal right-to-left and left-to-right NOTE: On some projectors, it may be necessary to stop the film to adjust the position of the cell.</p> <p>Lock the cell bracket into position after completing this adjustment. Check that the crosstalk has not changed as the bracket was tightened.</p>
<p>Verify that the outputs of the right and left solar cells are properly connected per the diagram in Step 2. Then place a white card over the right solar cell (nearer the outside of the projector) and verify that the level of the right channel drops — as indicated by the R LED on the Cat. No. 222 card, and the R LED on the Cat. No. 240A card.</p>
<p>Repeat the SMPTE Buzz Track alignment in Step 8. If the film or optics/exciter lamp position must be readjusted, repeat Step 9. The optimum setting is attained when no further adjustments are required in Steps 8 and 9.</p>

A-Chain Alignment Procedures

b. Optical Preamp Adjustments

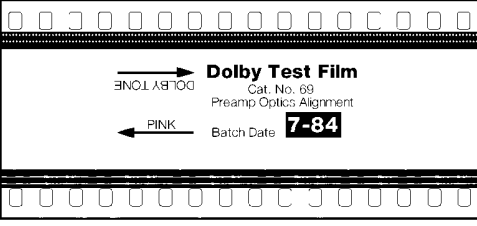
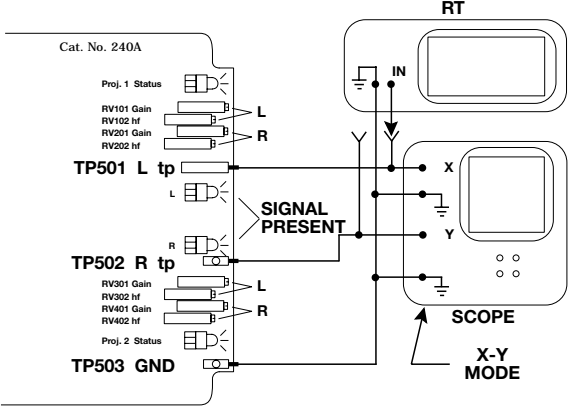
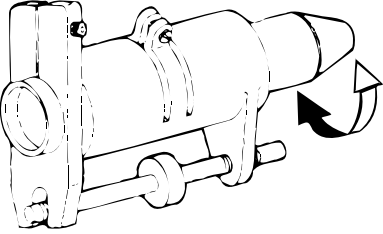
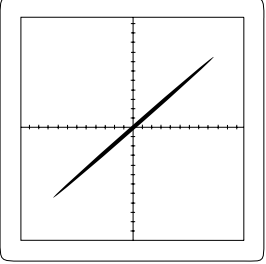
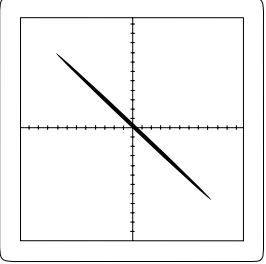
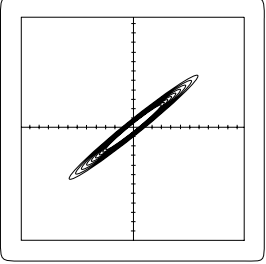
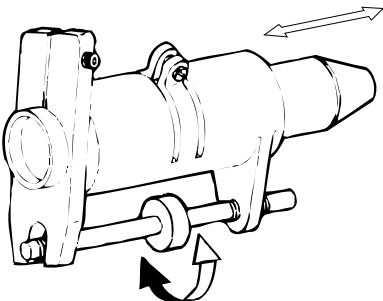
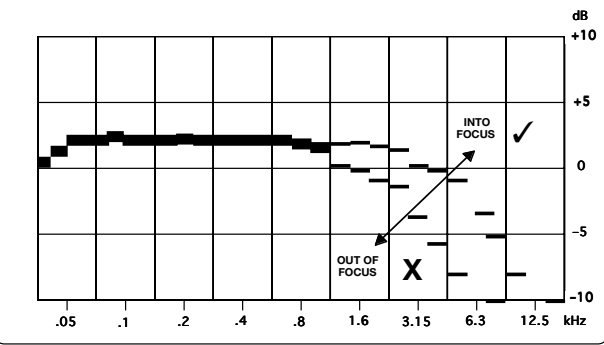
Step No.	Action	Indication
12	<p>Dolby Tone</p>  <p>Pink Noise</p>  	<p>OSCILLOSCOPE TRACES</p>  <p>✓</p>  <p>X Out of phase</p>  <p>X Incorrect azimuth</p>
13		 <p>RTA DISPLAY</p>

A-Chain Alignment Procedures

b. Optical Preamp Adjustments

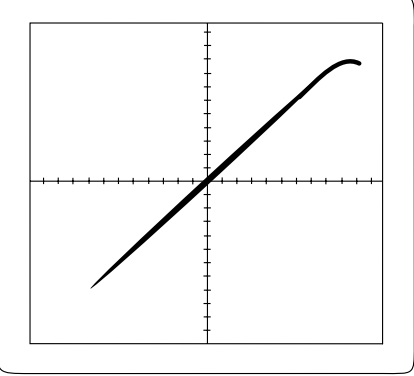
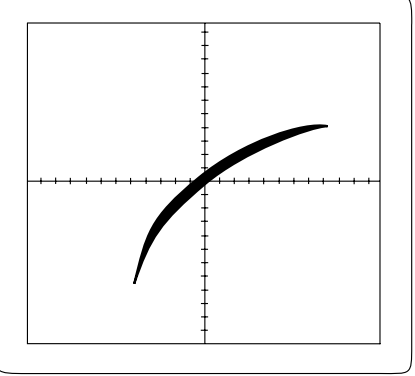
Notes
<p>Remove the Cat. No. 97 film and thread and play the pink noise on the Cat. No. 69 film (emulsion away from screen). Connect the RTA to the left test point TP501 L on the Cat. No. 240A.</p> <p>Switch the oscilloscope to the X/Y mode and adjust the azimuth of the projector optics for the narrowest diagonal trace. (Blooming at the ends of the trace may be caused by improper lighting of the edges of the optical tracks. If necessary, repeat steps 8 and 9 above, or step 5 on page 4-4 to reduce such blooming to a minimum.)</p>  <p>X Not enough light on one channel</p>  <p>X Uneven light on cell</p>
<p>Then, while observing the trace on the RTA, adjust the focus of the sound track lens for the best high frequency response. The trace shown in the example is ideal; merely attempt to obtain the best response. The azimuth and focus adjustments interact so you must repeat Steps 12 and 13 until no further adjustments are required.</p>

A-Chain Alignment Procedures

b. Optical Preamp Adjustments

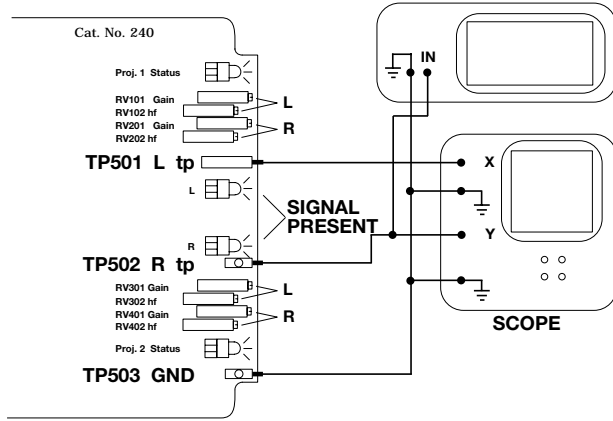
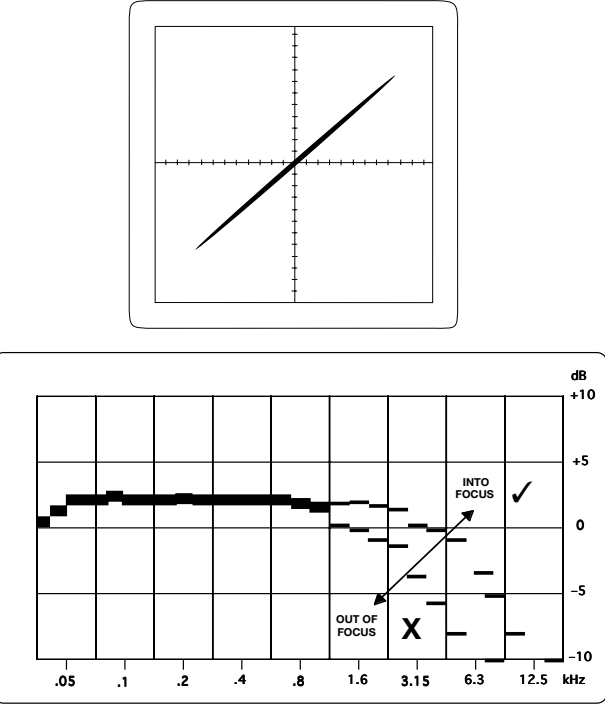
Step No.	Action	Indication
14	 <p>REPEAT 12 AND 13</p>	

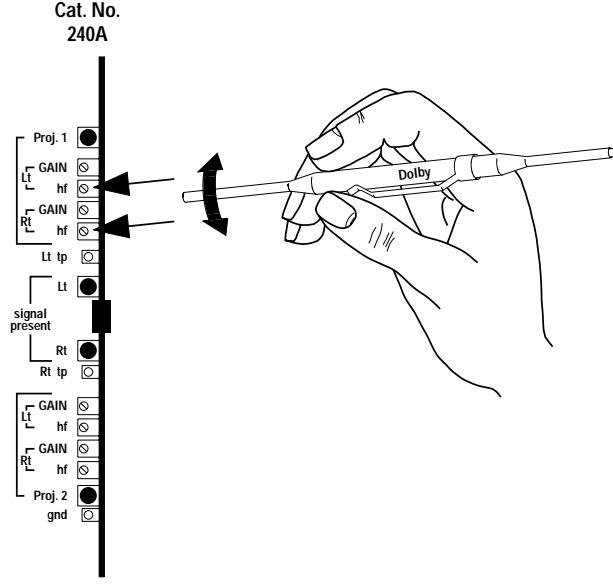
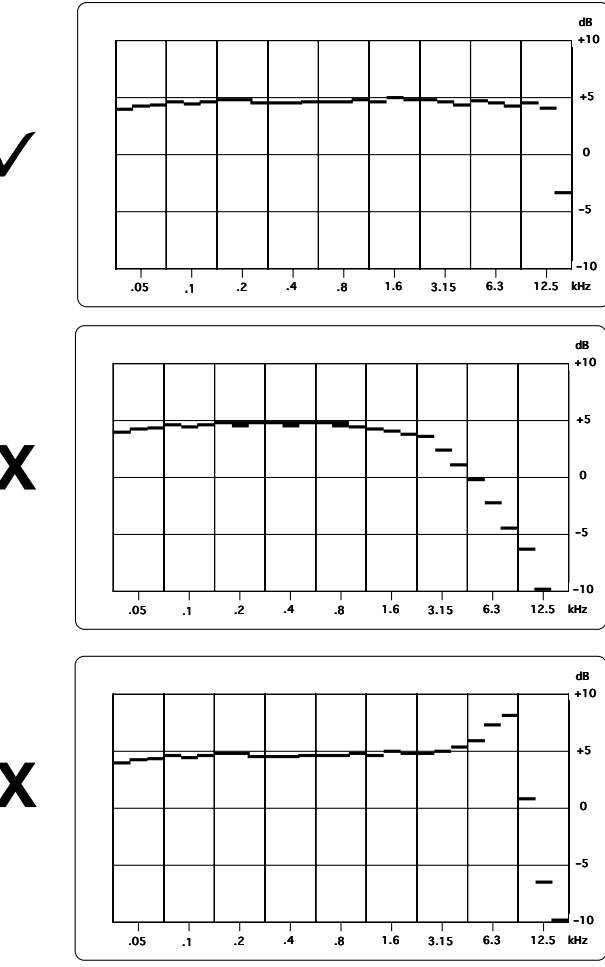
15		
----	---	--

A-Chain Alignment Procedures

b. Optical Preamp Adjustments

Notes
<p>Disconnect the RTA from the left test point and connect it to the right test point TP502 R. Then repeat Steps 12 and 13. NOTE: The azimuth and high frequency response must be the same at both the left and right test points. If results are not similar, it may be necessary to remove the lens and check for oil or contamination or a degraded slit. Replace the lens, if necessary. Do not proceed to the next step until the outputs at both the left and right test points are similar.</p>
<p>Appendix B shows the effects of slit geometry on frequency response.</p>

<p>The test in this step is performed both at the right and left channel test points of the Cat. No. 240A card.</p>
<p>The frequency response must be within 1 dB to at least 12 kHz. Adjust the L hf and R hf potentiometers on the Cat. No. 240A card for the most extended high frequency response without "peaking." If these adjustments do not improve the frequency response, the problem may be a degraded slit or damage to the lens.</p>

A-Chain Alignment Procedures

b. Optical Preamp Amplifier Adjustments

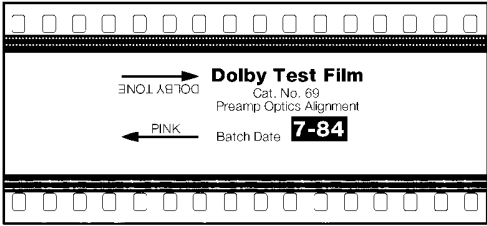
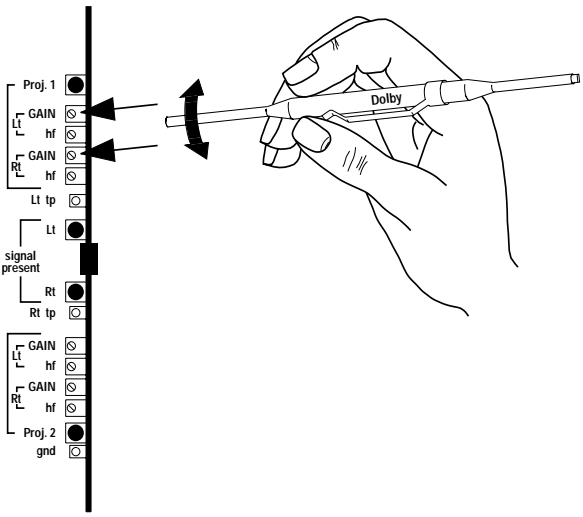
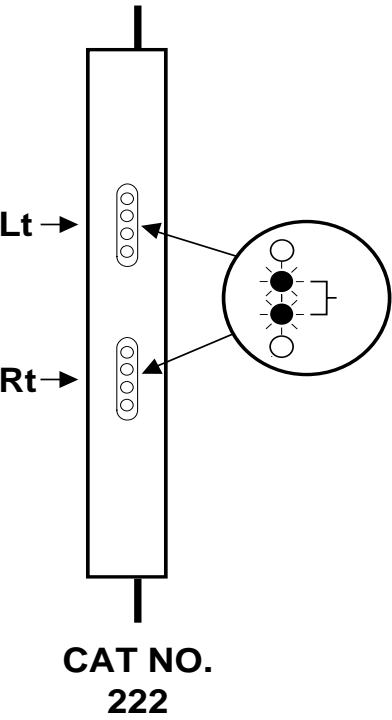
Step No.	Action	Indication
16	<p>Dolby Tone</p>  <p>Pink Noise</p> <p>Cat. No. 240A</p>  <p>Proj. 1 GAIN Lf hf Rf GAIN Lf hf Lf tp Lf signal present Rf Rf tp GAIN Lf hf GAIN Lf hf Proj. 2 gnd</p>	 <p>Lt →</p> <p>Rt →</p> <p>CAT NO. 222</p>
17	<p>FOR PROJECTOR NO. 2</p> <p>REPEAT 1 → 16</p>	

A-Chain Alignment Procedures

b. Optical Preamp Amplifier Adjustments

Notes
<p>Reverse the Cat. No. 69 test film to play Dolby tone. Verify that the Dolby tone indication is shown on the Cat. No. 222 card (the center two green LEDs are lit for both the R and L channels). If necessary, re-adjust the Proj 1 left and right gain controls on the Cat. No. 240A card. Do not re-adjust the hf controls.</p>
<p>Repeat all of the above steps for projector No. 2. If you purchased a spare Cat. No. 240A card, repeat steps 15 and 16 for the spare card so it will be ready for use immediately if the occasion arises.</p>

A-Chain Alignment Procedures

c. Magnetic Preamp Adjustments

Magnetic Alignment

The CP65 in its normal configuration does not provide noise reduction for signals entering through the Magnetic/Aux input. However an optional configuration using Cat. No. 300 SR/A modules in place of the normal Cat. No. 350 SR modules can be used for playing 70 mm Dolby Stereo prints. To use this option, headers J16, J17 and link J24 on the CP65 backplane must be in the correct position. See page 2-8 for information on the correct positions for J16, J17 and J24.

1. Inspect the magnetic head for evidence of wear. Wear can degrade the frequency response. De-magnetize the head and all elements in the film path, both metal and plastic (some plastic parts may have steel centers). If you have an Annis gauss meter or its equivalent, verify that no elements in the film path are magnetized. Repeat the degaussing, as required.
2. Inspect the penthouse and perform any mechanical adjustments in accordance with the manufacturer's instructions. Verify that all bearings, gears, and guide rollers are in good working order.
3. Install the magnetic preamplifier according to the manufacturer's information.
4. Connect the magnetic heads to the MPU input barrier strip with high-quality shielded cable, Belden 8451 or equivalent. Connect the shield at the MPU end only.
5. **For a standard CP65** (fitted with Cat. No. 350 SR modules), no A-type noise reduction is provided for magnetic inputs.

- Connect the outputs of the magnetic preamplifier to the "from mpu - no nr" inputs on the **TB3** and **TB4** barrier strips. See the wiring diagram on page 2-3.

For a CP65-300 (fitted with Cat. No. 300 SR/A modules), A-type noise reduction is provided for L, C,R,S magnetic inputs.

- Connect the outputs of the magnetic preamplifier to the "from mpu - (format 42)" inputs on **TB6** (L,C,R,S) and "fmt 42" input on **TB4** (Le, Re). See the wiring diagram on page 2-4.

6. Place the **NORMAL/BYPASS** switch in the **BYPASS** position.

A-Chain Alignment Procedures

c. Magnetic Preamplifier Adjustments

Magnetic Alignment

7. Remove the Cat. No. 242 card and locate the reversible plug-in Magnetic Input Sensitivity header.

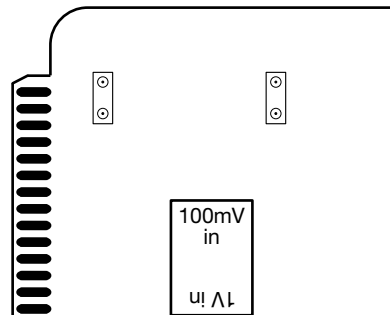

The CP65 accepts a nominal operating input level of either 100 mV or 1V — chosen by the position of the reversible plug-in header. The input impedance of the CP65 is 100K at both input levels. In addition, some preamplifiers may require a termination resistor (usually 600 ohms). You can connect the termination resistors at the input barrier strip TB3 and TB4 "from mpu-no nr" terminals on the backplane. Note that changeover between projector 1 and projector 2 must be accomplished in the magnetic preamplifier.

If noise reduction is to be used for decoding 70 mm Dolby Stereo soundtracks, the header on the Cat. No. 242 B-chain card must be set to the 100 mV position.



If the existing non-Dolby magnetic preamplifiers are used, their compatibility with the CP65 must be ensured.

8. Re-install the Cat. No. 242 card and restore the **NORMAL/BYPASS** switch to the **NORMAL** position.

SECTION 5
B-CHAIN ALIGNMENT

B-Chain Alignment Procedures

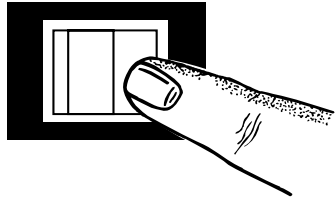
a. Setting Room Equalization

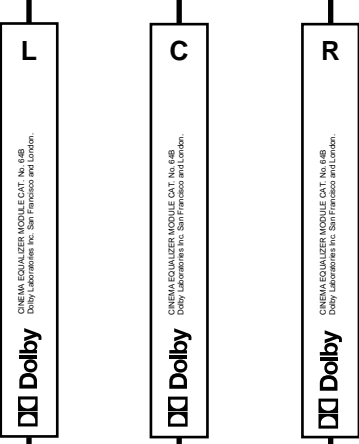
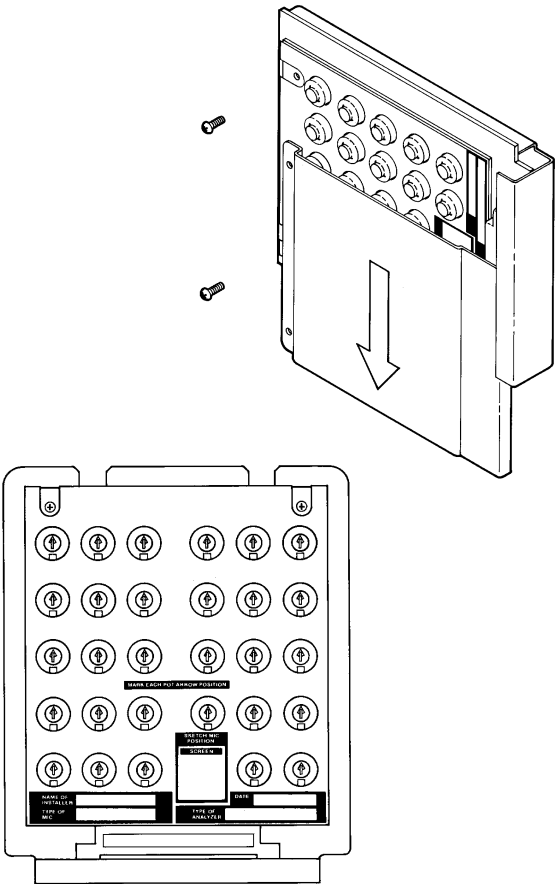
Step No.	Action	Indication
1	<p>NORMAL BYPASS</p> 	<p>bypass </p> <p>(switch behind panel)</p>
2		
3		

B-Chain Alignment Procedures

a. Setting Room Equalization

Notes
<p>Open the front panel and place the NORMAL/BYPASS switch in the BYPASS position so power is removed from the Cat. No. 64 Equalizer modules and the loudspeakers are protected. The BYPASS LED should be flashing.</p>
<p>Use the labels that are furnished with the CP65 to mark the three Equalizer modules as L, C, and R respectively. The labels make it easy to restore the modules to their correct positions after they have been removed.</p>
<p>Remove all of the marked Equalizer modules. Remove the shield cover from each equalizer and verify that all of the equalizer controls are set to the mid-position (12 o'clock). Replace the screws to avoid losing them then plug each of the equalizer modules with its cover removed back into the CP65 in its proper slot.</p>

B-Chain Alignment Procedures

a. Setting Room Equalization

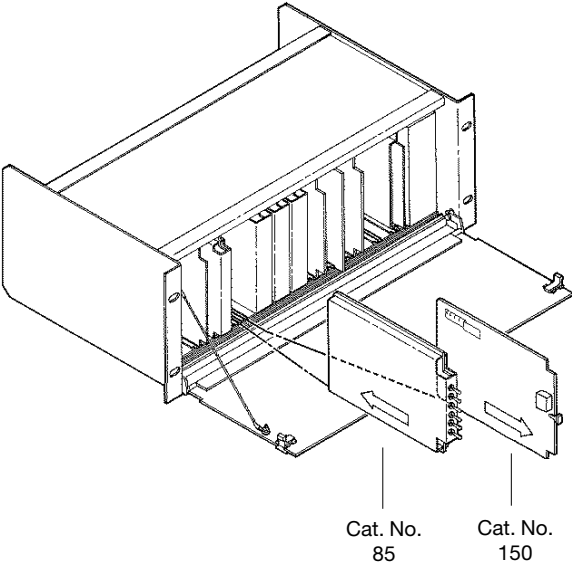
Step No.	Action	Indication
4	 <p style="text-align: center;">Cat. No. 85 Cat. No. 150</p>	
5		



B-Chain Alignment Procedures

a. Setting Room Equalization

Notes
<p>Remove the Cat. No. 150 Card. Note that when the Cat. No. 150 card is removed, two card edge connectors are exposed on the backplane and that another slot to the immediate left of the Cat. No. 150 slot is accessible. This second slot and associated connector are for the Cat. No. 85C Pink Noise Generator.</p> <p>Install the Cat. No. 85C Pink Noise Generator in the special slot to the left of the Cat. No. 150 slot. The switches in the Cat. No. 85C are up or down for ON and center for OFF. The phase is positive when the switches are in the up position and negative in the down position.</p>
<p>Loudspeakers and Crossovers</p>
<p>Thoroughly check the loudspeakers and power amplifiers for sources of poor performance:</p> <ul style="list-style-type: none"> • Check that the loudspeaker cables are in good condition and that they of a suitable gauge for the impedance of the speakers and the length of the run. • Rattles (a leak in the woofer cabinet may appear to be a rattle). • Loose bolts or other hardware. • Open drivers. <p style="margin-left: 20px;">In systems with pairs of drivers — woofers or tweeters — one of the pair may be open but the system will still function. Check the speakers with an ohmmeter. If one channel requires markedly more equalization than the other or if one speaker overloads at lower levels than the other speakers, an open driver circuit could be the cause.</p> • Missing drivers or other components. • The settings of the crossovers to match the type of drivers in use and the acoustics of the theater. <p style="margin-left: 20px;">The tweeter level control must be set for the best possible frequency response with the Cat. No. 64 controls all at mid-point before you attempt any equalization. (The same procedures should be followed if the system uses active crossovers with bi-amp equipment.) This check should be made with a real time analyzer.</p> • Phasing between the woofers and tweeters, and between the channels (see Appendix A). • Aiming of speakers. <p style="margin-left: 20px;">Check that the speakers are correctly aimed into the auditorium, and that they are not obstructed by the screen frame, struts or other obstructions.</p>

B-Chain Alignment Procedures

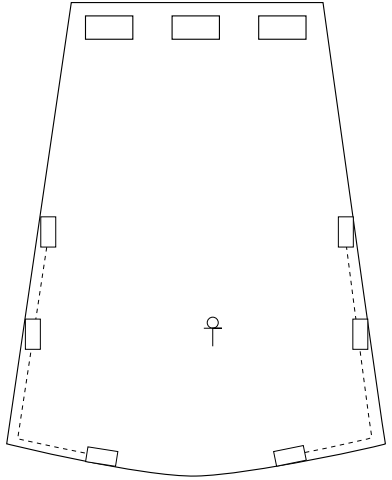
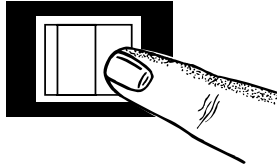
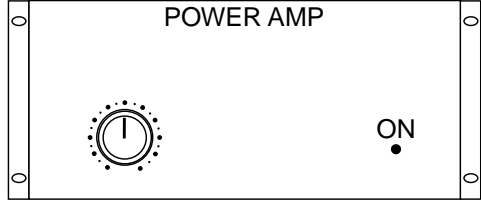
a. Setting Room Equalization

Step No.	Action	Indication
<p>5 CONT'D</p>		
<p>6</p>		
<p>7</p>	<p>NORMAL BYPASS</p>  <p>POWER AMP</p> 	<p>bypass </p> <p>(switch behind panel)</p>

B-Chain Alignment Procedures

a. Setting Room Equalization

Notes
<ul style="list-style-type: none"> • Check that speakers are correctly connected; that the speaker on the left is really connected to the left power amplifier. <p style="text-align: center;">Amplifiers</p> <ul style="list-style-type: none"> • Distortion. • Gross gain differences among amplifiers. If one amplifier differs in performance from the others, it should be checked and repaired, if necessary, before proceeding further. Input gain controls should all be at the same setting. • Blown fuses. Some types of power amplifiers operate at very low gain and distortion even if fuses are blown. • Good air movement through power amplifiers. <p style="text-align: center;">General</p> <p>If air-conditioning noise is audible in the theatre, arrange for lubrication of the motor, fan bearings, adjustment of belts and drives and cleaning of filters to reduce the ambient noise to a minimum.</p>
<p>Set all the gain controls on all power amplifiers to a known repeatable setting, but do not turn amplifiers on. The preferred setting for the amplifier gain controls is maximum. If a different setting is required in order to optimize the noise performance of the system, the controls should be locked in position or marked clearly.</p> <p>Position calibrated microphones in the theatre. Whenever possible use multiple microphones and a multiplexer.</p> <p>For a single microphone the recommended position is shown in the diagram — 2/3 of the way from the front speakers to the rear — but off the axis of the center speaker — 5 feet off the floor level — and angled 45 degrees upward toward the screen. Connect the microphone to the RTA.</p>
<p>Open the front door of the CP65 and ensure that the NORMAL/BYPASS switch is in the BYPASS position.</p> <p>Turn power ON to the power amplifiers.</p>

B-Chain Alignment Procedures

a. Setting Room Equalization

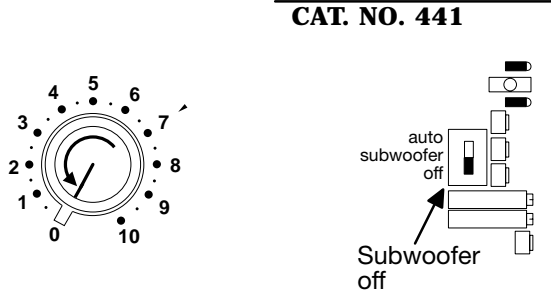
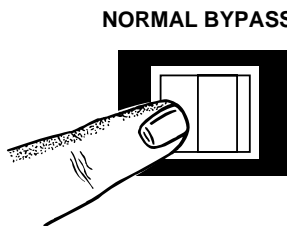
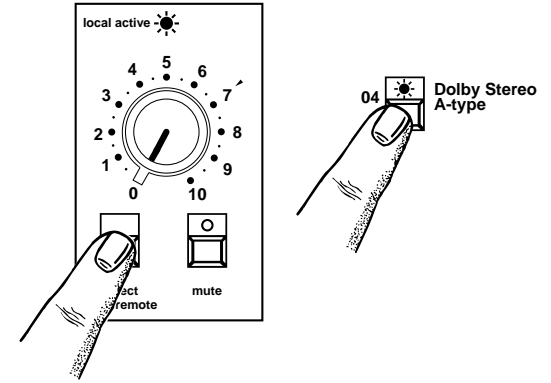
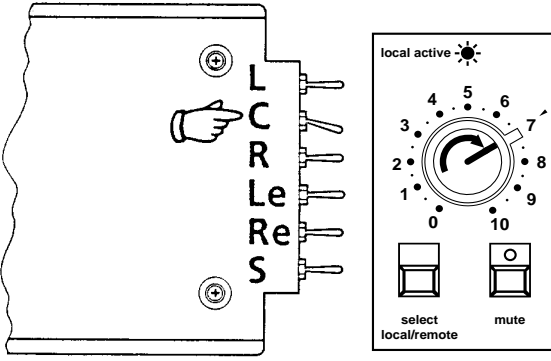
Step No.	Action	Indication
8	 <p>CAT. NO. 441</p>	
9	 <p>NORMAL BYPASS</p>	
10	 <p>local active</p> <p>select local/remote</p> <p>mute</p> <p>04 Dolby Stereo A-type</p>	
11	 <p>L C R Le Re S</p> <p>local active</p> <p>select local/remote</p> <p>mute</p>	

B-Chain Alignment Procedures

a. Setting Room Equalization

Notes
<p>Set the FADER to the 0 position.</p> <p>If a Cat No. 441 Surround Equalizer, Subwoofer card is fitted set the subwoofer switch to the OFF position.</p>
<p>Set the NORMAL/BYPASS switch to the NORMAL position.</p>
<p>Verify that the fader local active LED is on. If necessary, press the select local/remote switch.</p> <p>Press the 04 Dolby Stereo A-type switch; the LED in the switch should light.</p>
<p>Switch on the center channel pink noise on the Cat. No. 85 Pink Noise Generator (C switch up or down).</p> <p>Slowly advance the FADER control to position 7. You should hear pink noise.</p>

B-Chain Alignment Procedures

a. Setting Room Equalization

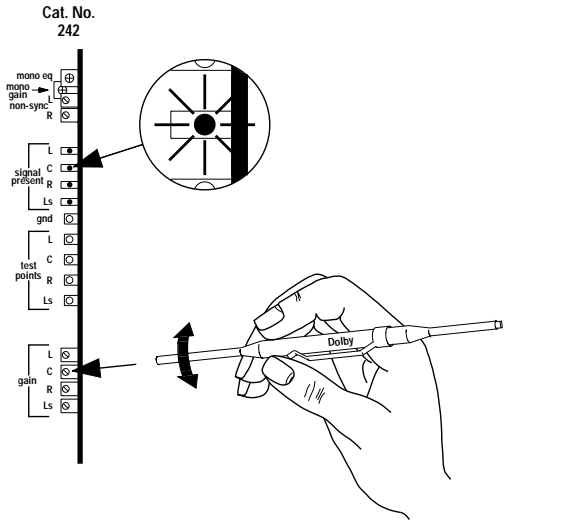
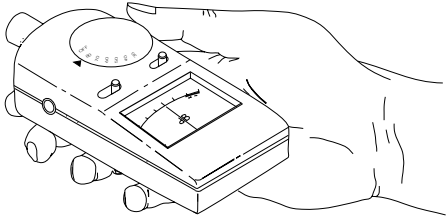
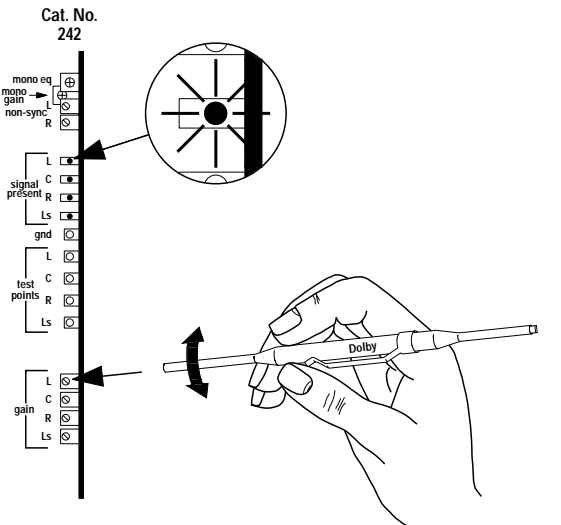
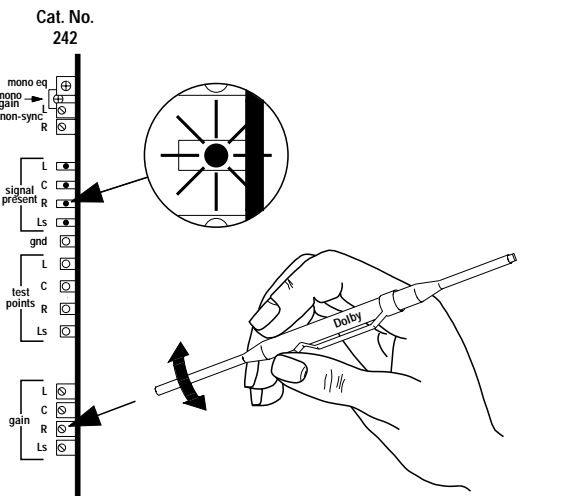
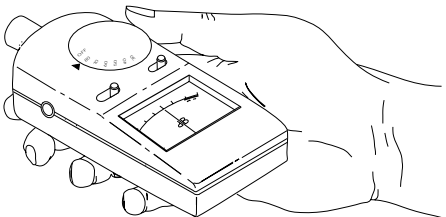
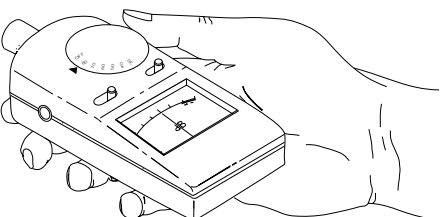
Step No.	Action	Indication
12		<p>75-80 dBC</p> 
13	<p>REPEAT 11 → 12</p>  	<p>75-80 dBC</p>  <p>75-80 dBC</p> 



B-Chain Alignment Procedures

a. Setting Room Equalization

Notes
<p>With a sound pressure level meter located at the position in the theatre used for step 6, adjust the center channel gain on the Cat. No. 242 card until the channel produces a reading of 75-80 dBC. (After room equalization for all channels is set, the sound pressure level will be set to 85 dBC.) The pink noise should be at least 20 dB above the background noise level of the theatre. If a level of 75-80 dBC cannot be obtained, adjust the gain of the amplifiers and try again. A row of four LEDs, signal present L, C, R and S, is on the front edge of the Cat. No. 242 card. Each LED indicates the presence of signal for the appropriate channel and lights intermittently when pink noise is sent through the system from the Cat. No. 85C or from a film.</p>
<p>Repeat steps 11 and 12 for the left and right channels. Switch on the appropriate pink noise switch on the Cat. No. 85C pink noise generator, one channel at a time.</p> <p>Compare the response displayed on the real time analyzer (RTA) for each channel (L, C, R). All should show a similar shape. Any large differences indicate faulty or misaligned crossovers or defective speakers. Speaker phasing could also be at fault. See Appendix A.</p>

B-Chain Alignment Procedures

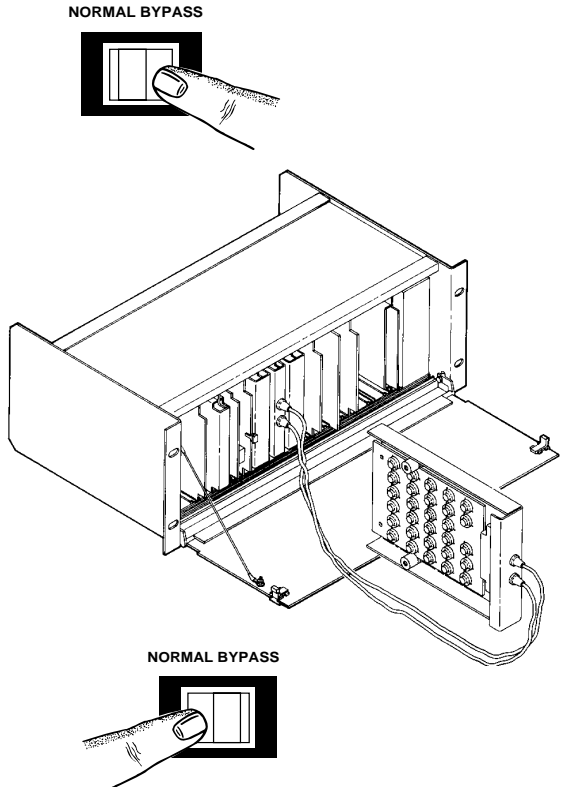
a. Setting Room Equalization

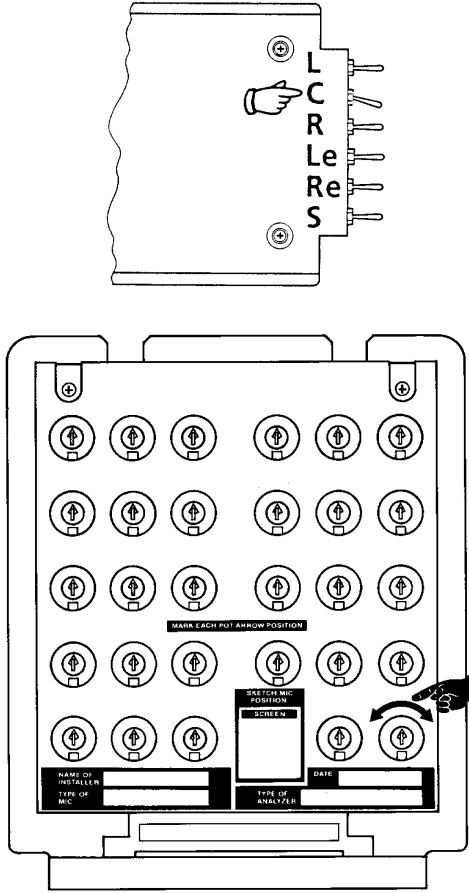
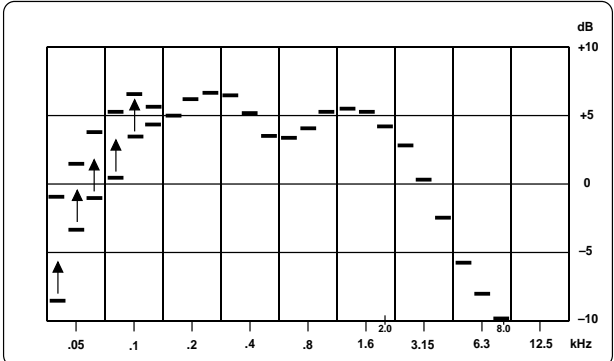
Step No.	Action	Indication
14		<p>bypass (switch behind panel)</p>  <p>04  Dolby Stereo A-type</p>
15		

B-Chain Alignment Procedures

a. Setting Room Equalization

Notes
<p>Change the NORMAL/BYPASS switch to the BYPASS position. Remove the center channel Cat. No. 64 equalizer module and plug the Cat. No. 67 extender in its slot. Then plug the equalizer module into the free end of the extender.</p>
<p>Restore the switch to the NORMAL position and make certain the format switch is still in the 04 position.</p>
<p>Turn on the center channel only on the Cat. No. 85C.</p>
<p>While observing the RTA display, adjust the bass control on the Cat. No. 64 so the bass frequency response is approximately flat. Once you set this control, do not change the setting during the rest of the room equalization procedure.</p>

B-Chain Alignment Procedures

a. Setting Room Equalization

Step No.	Action	Indication
16		
17		

X Do not adjust

B-Chain Alignment Procedures

a. Setting Room Equalization

Notes
<p>While observing the frequency response curve on the RTA, adjust the treble control on the Cat. No. 64 for a flat response as close as possible up to 2 kHz, followed by a 3 dB per octave roll-off above 2 kHz (the frequency response specified in ISO Standard 2969). Once you set this control, do not change the setting during the rest of the room equalization procedure.</p>
<p>The next step is to fine-tune the equalization by adjusting the third-octave controls on the Cat. No. 64 equalizer. There are certain rules to keep in mind:</p>
<ul style="list-style-type: none"> • The object is to achieve the final adjustment of room equalization with all of the controls as close to the 12 o'clock position as is possible. • All of the equalizer controls interact with each other so you should not start at the low end of the response curve and merely work your way to the high end. As each control is adjusted, the response obtained by adjustment of adjacent controls is affected. • Start at the center frequency and attempt to achieve results with cut rather than with boost. The desired curve is a flat frequency response up to 2 kHz, falling at 3 dB per octave to 8 kHz (1 dB per third-octave band). Do not change the position of the 50 Hz or 40 Hz band controls nor turn the controls for bands above 8 kHz unless you have modern loudspeakers. This protects the loudspeakers and power amplifiers from damage and prevents distortion of the reproduced sound. • If modern woofer systems (vented-box direct radiator enclosures) are installed in the theatre, moderate bass equalization down to 40 Hz may be used. • Once an adjustment seems OK, work on the frequencies to either side of it. You may find that a cut at one frequency is followed by a slight boost at adjacent frequencies. • Control settings should not fall outside the band between the 9 o'clock and the 3 o'clock positions. • Avoid diametrically opposed adjacent control settings.
<p>Adjust for the response that is closest to the curve shown. The diagrams show a typical equalization procedure, from the response before equalization to the final equalization.</p>

B-Chain Alignment Procedures

a. Setting Room Equalization

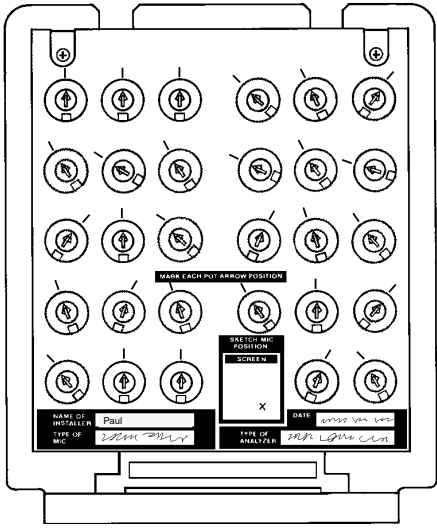
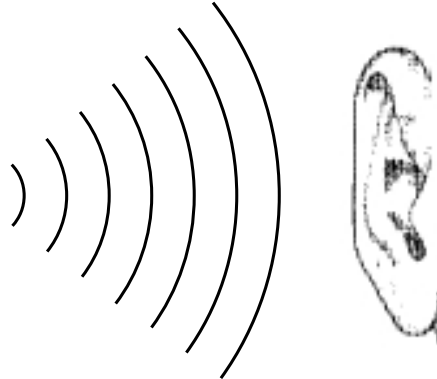
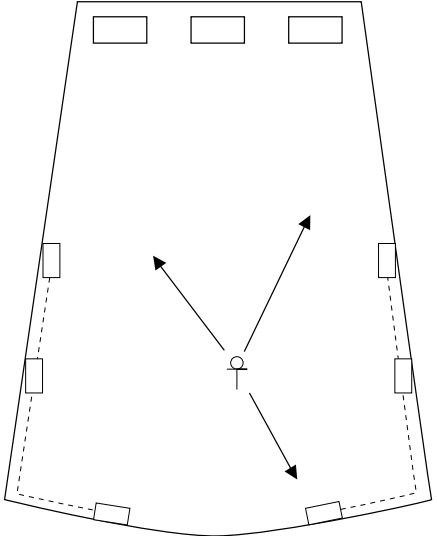
Step No.	Action	Indication
18		
19		
20		

B-Chain Alignment Procedures

a. Setting Room Equalization

Notes
<p>When equalization is completed, the average of the 27 third-octave band controls should be approximately 12 o'clock (not mostly up or down). If you find the controls are set differently, repeat the equalization procedure until you obtain the proper equalization; settings that diverge from this average may result in unpleasant sound.</p>
<p>Although the equalization may be set correctly for the chosen microphone position, it still may not be correct for providing the best sound to the greatest number of seats in the theater. You should therefore check the sound quality at several locations (three or more) in the auditorium with the calibrated microphone and RTA system. If time does not permit this procedure, walk around the theater with pink noise playing. If necessary, adjust the equalizer for a compromise at several seat positions so that all of them sound acceptable.</p>
<p>Mark the settings for each control on the white card provided inside the Cat. No. 64 module.</p>
<p>If the sound quality varies significantly as you walk around, the equalization has not been adequate:</p>
<ul style="list-style-type: none"> • You may have over equalized. Check the positions of the controls; all should be as close to 12 o'clock as possible. • There may be phase shift present if the adjacent controls are pointed in opposite directions, especially if you did so to eliminate a sharp dip that resulted from physical problems in the auditorium (horn location, speaker orientation). • The size of the room may be a multiple of a given wavelength, wall surfaces are parallel, or there may be a severe balcony overhang. There may be reflection off the walls behind the screen or crosstalk from adjacent theatres. • The seat and seat materials may be too reflective. • The microphone may have been placed in an untypical position.
<p>Repeat the procedure with the microphone in other average locations in the auditorium. Adjust the controls for the best compromise to fit all of the locations of the microphone.</p>

a. Setting Room Equalization
 b. Adjusting L,C,R Gain

B-Chain Alignment Procedures

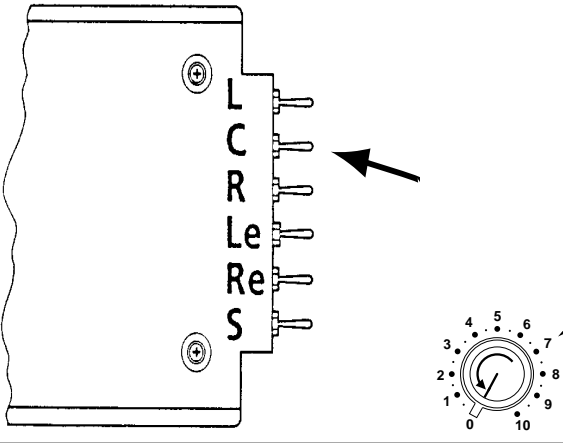
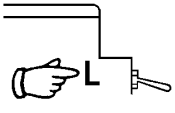
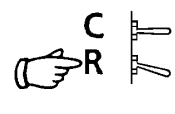
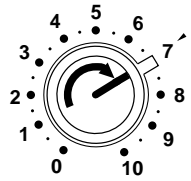
Step No.	Action	Indication
21		
22	REPEAT L 14 → 21  R 14 → 21 	
23		

b. Adjusting L,C,R Gain

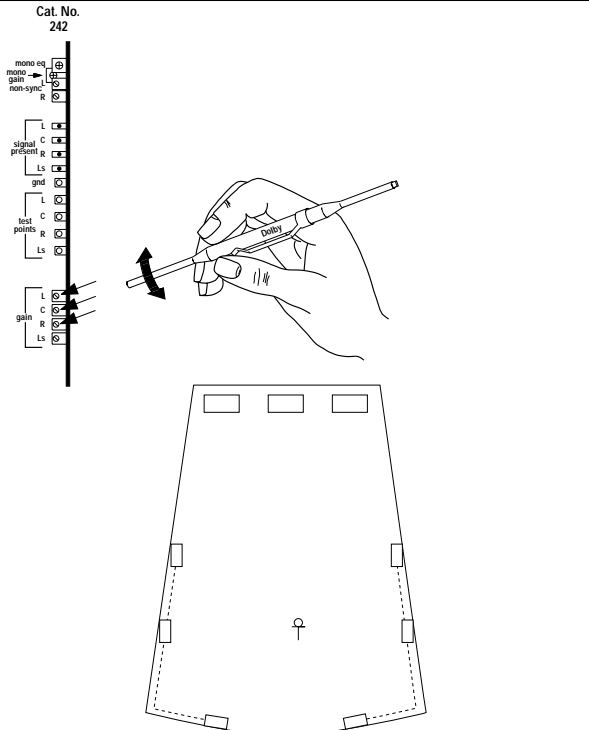
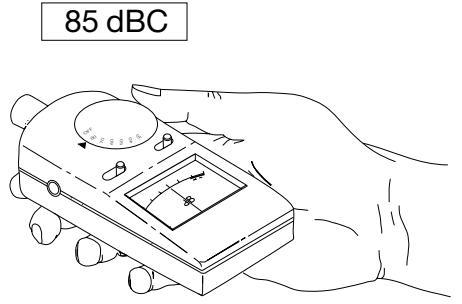
1		
---	---	--

B-Chain Alignment Procedures
 a. Setting Room Equalization
 b. Adjusting L,C,R Gain

Notes
Turn off the pink noise on the center channel. Turn the fader to 0 or press the Mute button.
Disconnect the center equalizer module from the extender and then remove the extender from the CP65. Re-install the cover on the module and plug it back in. Repeat for the left and right channel equalizer modules, using the Cat. No. 67 extender.
Turn the fader back to '7' or press the mute button again.

b. Adjusting L,C,R Gain

Turn the pink noise switches L, C, R on one at a time and adjust the L, C and R gain controls on the Cat. No. 242 B-Chain Card so that each channel produces 85dBC in the theatre, as measured by the sound level meter at the standard location described in Step 15 above. Be sure that the front panel FADER is set to 7, format 04 is selected, and the subwoofer is off during this step.
--

B-Chain Alignment Procedures

c. Setting Mono Gain

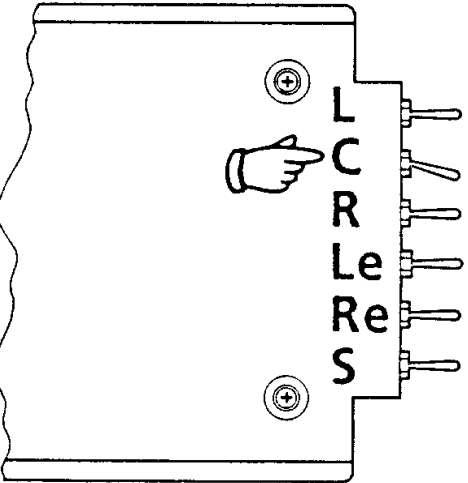
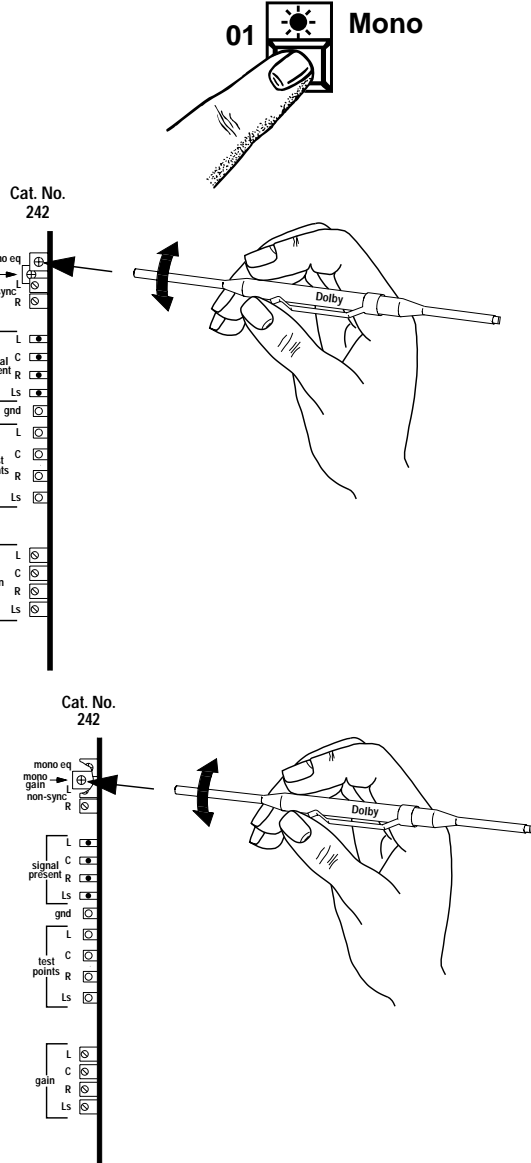
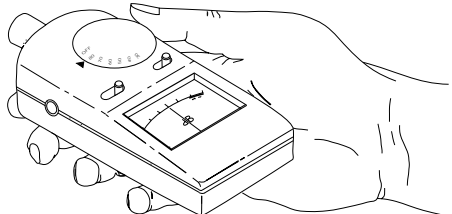
Step No.	Action	Indication
1		
2		<p>Ⓜ MIDPOINT</p> <p>79 dBC</p> 

B-Chain Alignment Procedures

c. Setting Mono Gain

Notes
<p>Turn on the center C channel of the Cat. No. 85C Pink Noise Generator.</p>
<p>Press the format 01 Mono switch.</p> <p>Set the mono eq control on the Cat. No. 242 B-Chain Card (top control) to the midway position.</p> <p>Adjust the mono gain control (just under the mono eq control) for 79 dBC.</p> <p>The mono eq control adjustment is covered later.</p>

B-Chain Alignment Procedures

d. Subwoofer Alignment (Cat. No. 441)

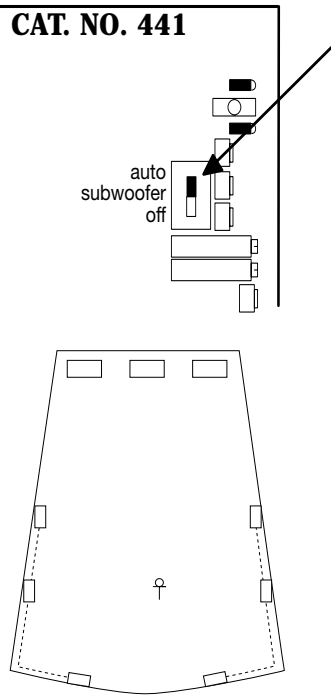
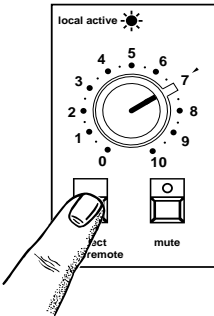
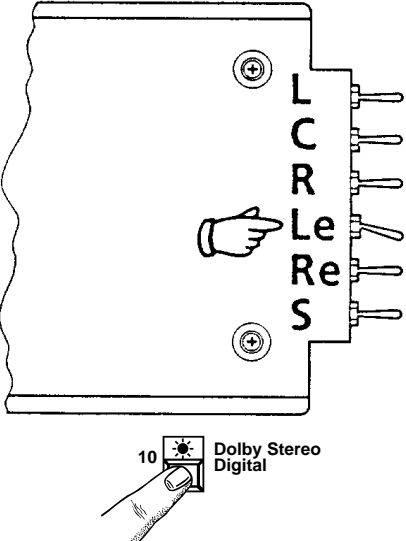
Step No.	Action	Indication
1	<p>CAT. NO. 441</p> 	
2		
3		

B-Chain Alignment Procedures

d. Subwoofer Alignment (Cat. No. 441)

Notes
<p>CP65 processors may be supplied in a number of different configurations.</p> <p>If the CP65 being installed does not contain a Cat. No. 441, skip this procedure and the next procedure and go directly to part, Adjustment of Surround Delay, on page 5-43.</p> <p>The Subwoofer auto/off switch on the Cat. No. 441 card enables the subwoofer in formats other than Non-sync (format 60), Mono (format 01) and magentic no NR (format 22). The switch must be in the auto (up) position at any time the subwoofer system is to function.</p> <p>Confirm that the microphone is in the position defined on page 5-7.</p> <p>All connections established in the room equalization procedure apply to the following steps.</p>
<p>The main front panel FADER should be active and set to 7. If necessary, press the select local/remote switch.</p>
<p>Place the Le toggle switch on the Cat. No. 85C card in the ON (up or down) position and set the CP65 to format 10 Dolby Stereo Digital.</p>

B-Chain Alignment Procedures

d. Subwoofer Alignment (Cat. No. 441)

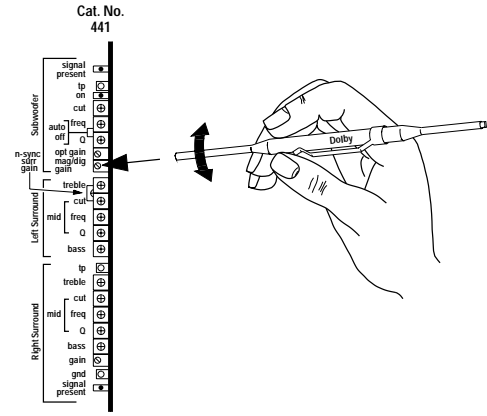
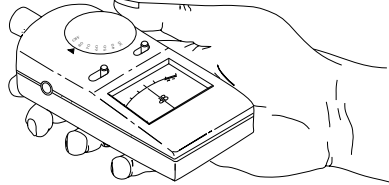
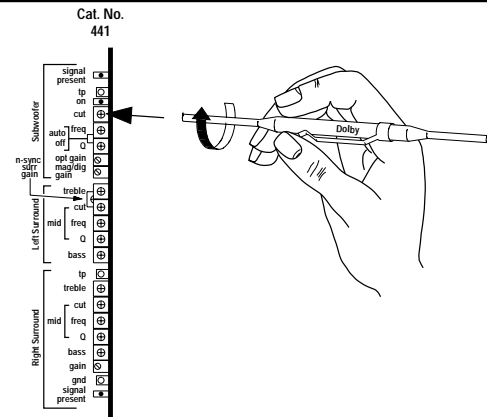
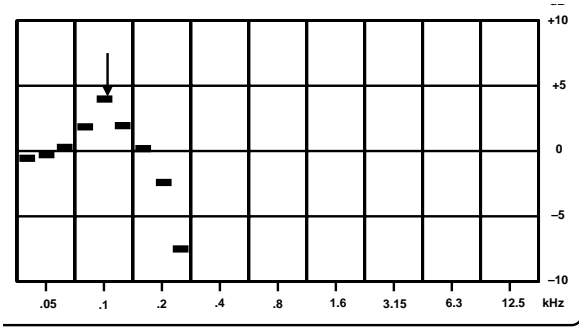
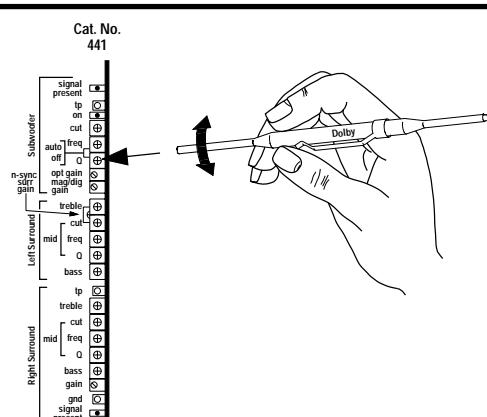
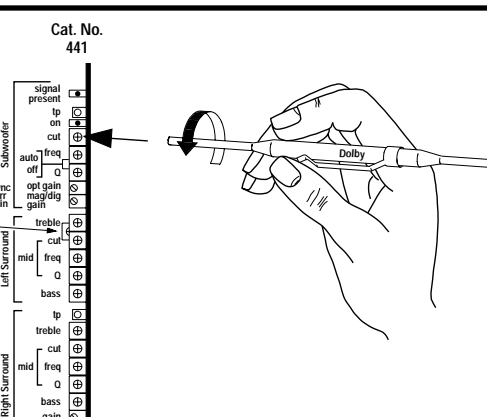
Step No.	Action	Indication
4		<p>90 dBC → 85 dBC</p> 
5		
6		
7		

B-Chain Alignment Procedures

d. Subwoofer Alignment (Cat. No. 441)

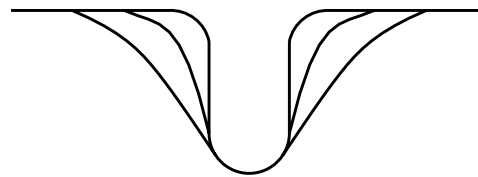
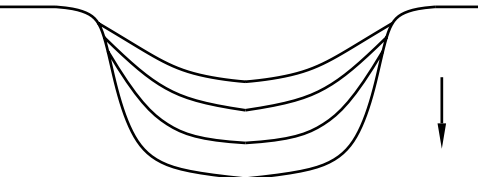
Notes
<p>Adjust the mag/dig gain control on the Cat. No. 441 card for a 90 dBC SPL (sound pressure level) in the theatre. (If this level cannot be obtained it may be necessary to change the J2 jumper setting to increase or decrease the output - - see page 2-5). When you have obtained this level turn the mag/dig gain control down for an 85 dBC SPL.</p>
<p style="text-align: center;">Note</p> <p style="text-align: center;"><i>This level is only an approximation. Sound pressure level meters are not appropriate for setting accurate levels of narrow band signals. The correct final level will be set later in this procedure using an RTA.</i></p>
<p>Turn the cut control at the top of the Cat. No. 441 card to the fully clockwise (CW) position for minimum cut. This disables the subwoofer equalizer circuit.</p>
<p>Note the frequency of the peak in the response. You will need this information in Step 9 following.</p>
<p>Turn the Q control on the Cat. No. 441 card to its mid point (for a moderately wide notch).</p>

<p>Turn the cut control back to the fully counterclockwise (CCW) position for full cut.</p>

B-Chain Alignment Procedures

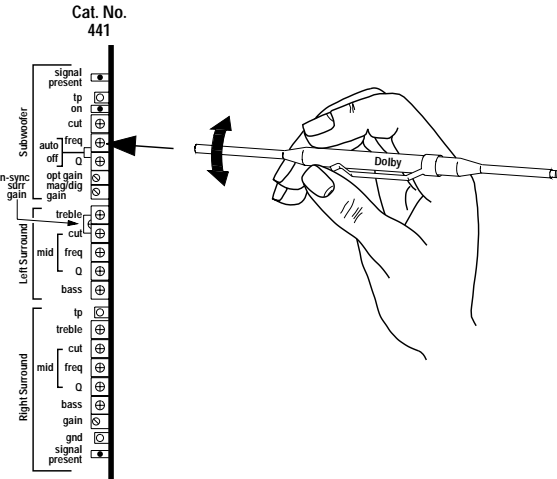
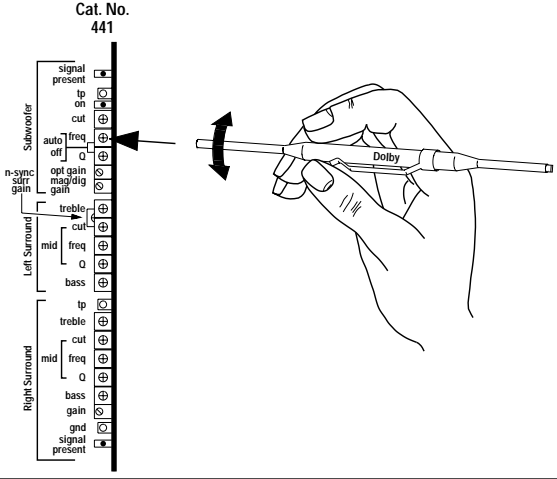
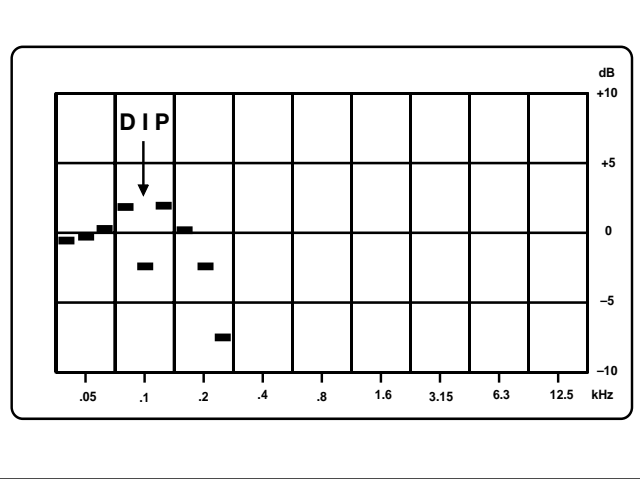
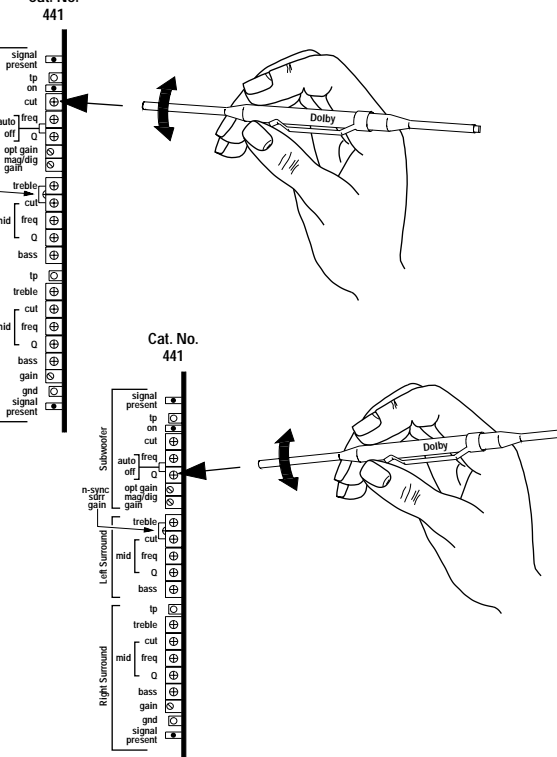
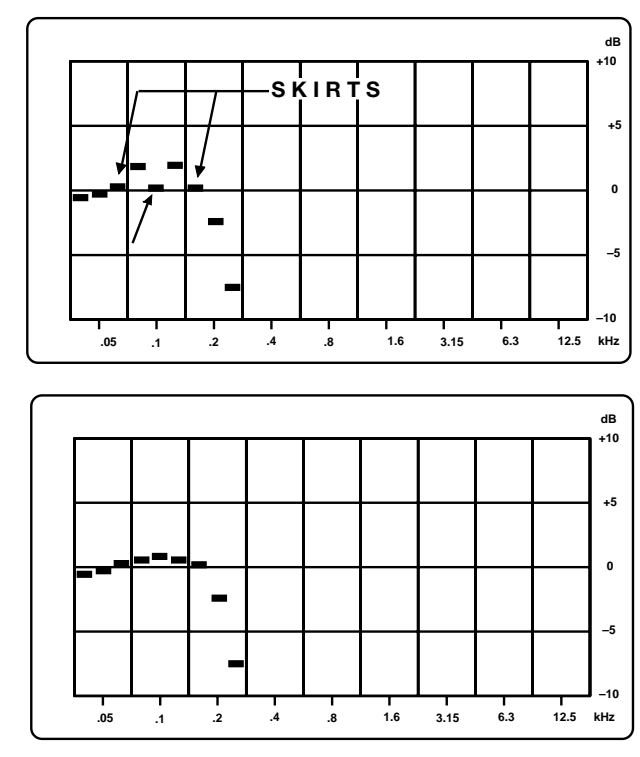
d. Subwoofer Alignment (Cat. No. 441)

Step No.	Action	Indication
8	<p>Cat. No. 441</p> 	
9	<p>Cat. No. 441</p> 	
10	<p>Cat. No. 441</p> 	

B-Chain Alignment Procedures

d. Subwoofer Alignment (Cat. No. 441)

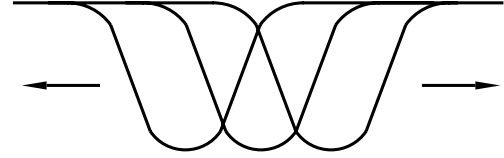
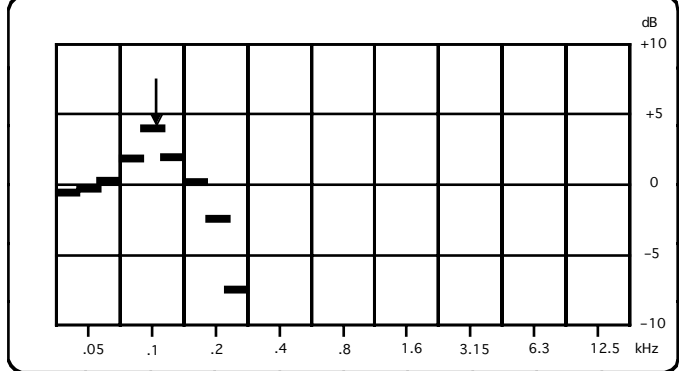
Notes
<p>Turn the freq control on the Cat. No. 441 card. A dip in the frequency response will move along the frequency axis of the RTA display.</p>

<p>Adjust the freq control so the center of the dip is in the same band as the highest peak in the unequalized subwoofer frequency response you were asked to take note of in Step 5.</p>
<p>FROM 5:</p>

<p>Adjust the cut control so the center of the dip flattens. The center of the dip should be at the same level as the skirts.</p>
<p>Adjust the Q control for the flattest possible frequency response.</p>

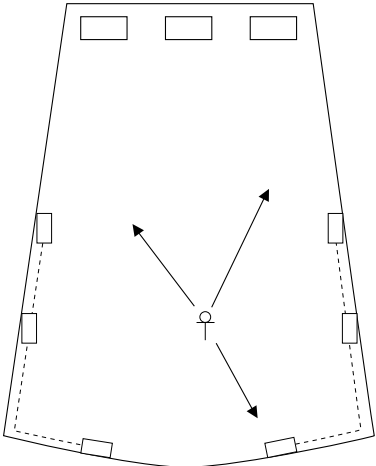
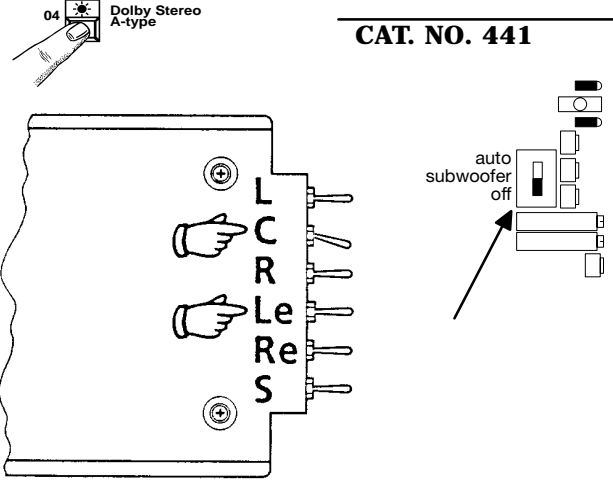
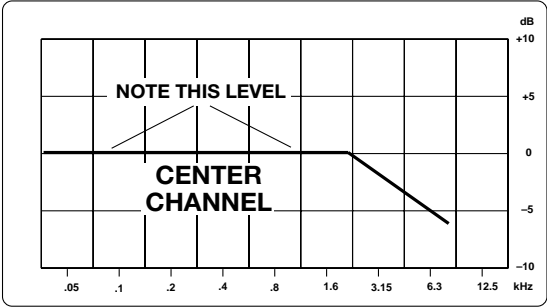
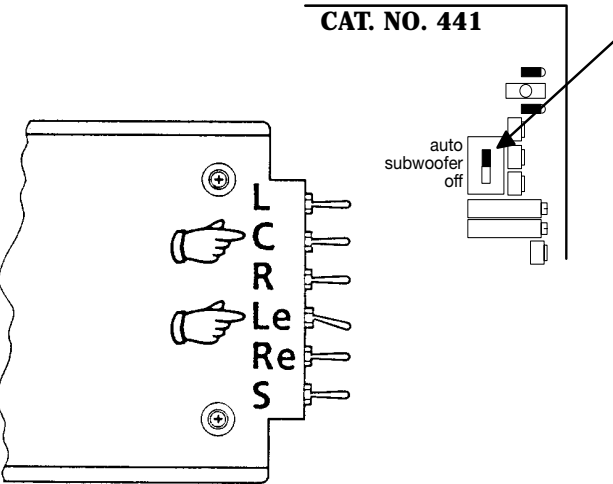
B-Chain Alignment Procedures

d. Subwoofer Alignment (Cat. No. 441)

Step No.	Action	Indication
11	 <p>REPEAT 8 → 10</p>	
12	 <p>CAT. NO. 441</p>	 <p>NOTE THIS LEVEL CENTER CHANNEL</p>
13	 <p>CAT. NO. 441</p>	

B-Chain Alignment Procedures

d. Subwoofer Alignment (Cat. No. 441)

Notes
<p>If using a single microphone, relocate the microphone to at least one other location in the theatre and check the audio spectrum on the RTA. Repeat the freq, cut, and Q adjustments to obtain a good average overall equalization at these locations of the microphone.</p>
<p>Select format 04 Dolby Stereo A-Type.</p> <p>Place the Le toggle switch on the Cat. No. 85C card in the OFF (center) position and place the C (center channel) toggle switch in the ON position.</p> <p>Place the subwoofer switch on the Cat. No. 441 in the OFF position.</p> <p>Note the average level of the third-octave bands between 100 Hz and 1 kHz.</p>
<p>Place the C toggle switch in the OFF (center) position and place the Le toggle switch in the ON (up or down) position.</p> <p>Place the subwoofer switch on the Cat. No. 441 in the auto position.</p>

B-Chain Alignment Procedures

d. Subwoofer Alignment (Cat. No. 441)

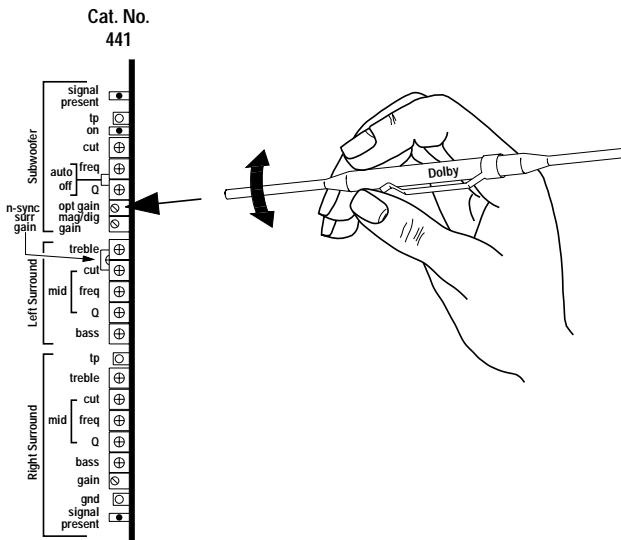
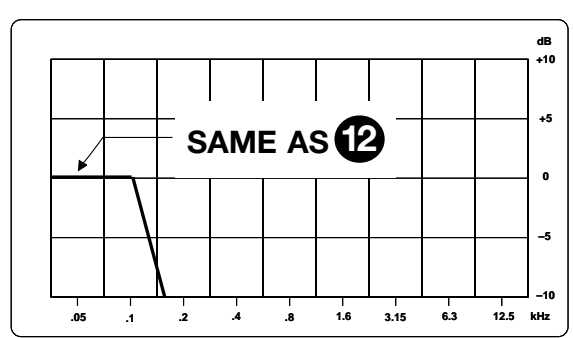
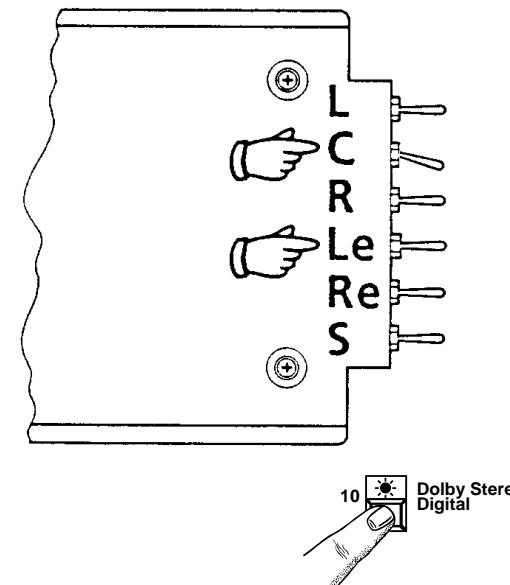
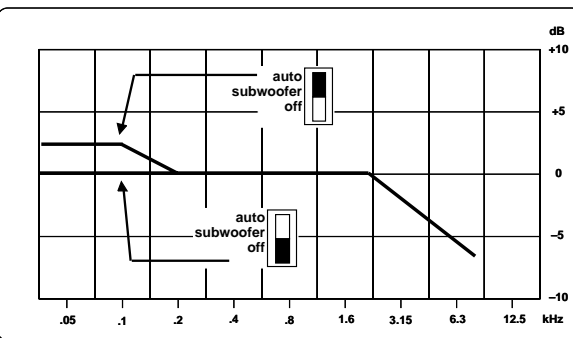
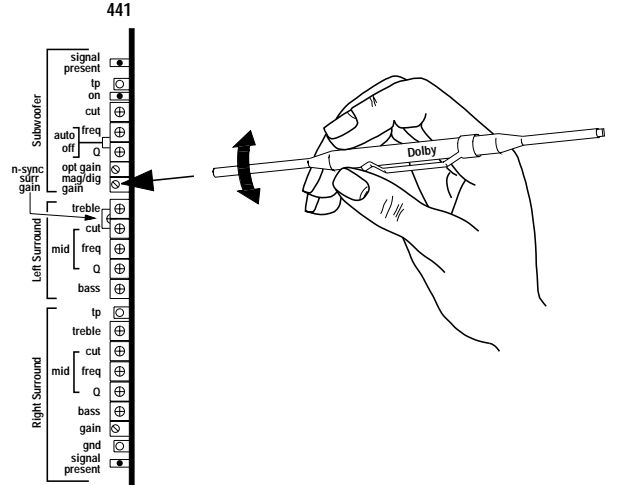
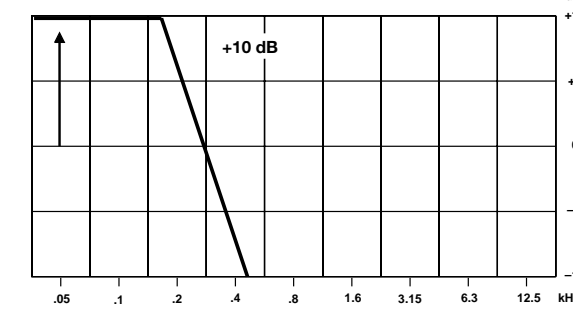
Step No.	Action	Indication
14		
15		
16		

B-Chain Alignment Procedures

d. Subwoofer Alignment (Cat. No. 441)

Notes
<p>Adjust the optical gain control on the Cat. No. 441 card so that the average level of the bands from the subwoofer is at the same level on the analyzer screen as you noted for the center channel in the previous step.</p>
<p>Place the Le toggle switch on the Cat. No. 85C card in the OFF (center) position and place the C (center channel) toggle switch in the ON position.</p> <p>Note the change in the average level of the bands from 20 Hz to 100 Hz when the subwoofer switch on the Cat. No. 441 is switched between OFF and AUTO. There should be a level INCREASE when it is switched to AUTO. The subwoofer is out of phase with the front channels if you do not see this level increase. Reverse the subwoofer(s) speaker connections.</p> <p>Re-select Format 10.</p>
<p>Adjust the mag/dig gain on the Cat. No. 441 so that the level of the bands from the subwoofer increases 10 dB above the level in the previous step.</p> <p>The subwoofer alignment is completed.</p>

B-Chain Alignment Procedures

e. Surround Equalization Alignment (Cat. No. 441)

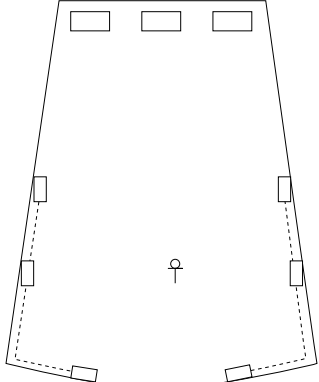
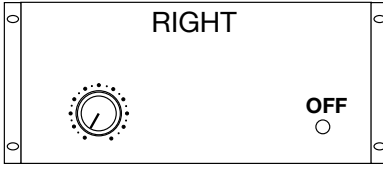
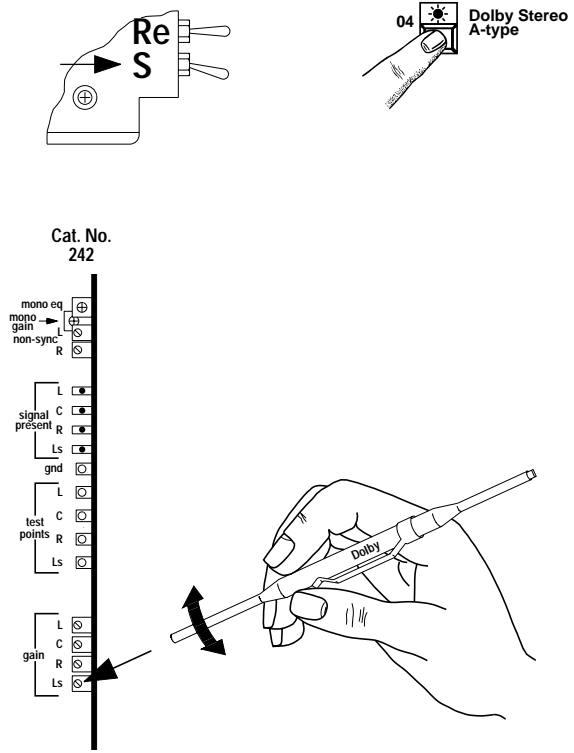
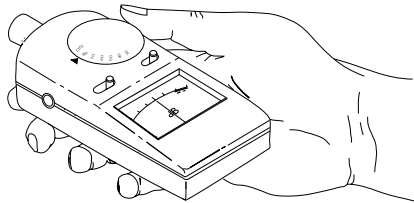
Step No.	Action	Indication
1		
2		
3		<p>MONO SURROUND STEREO SURROUND</p> <p>88 dBC 85 dBC</p> 



B-Chain Alignment Procedures

e. Surround Equalization Alignment (Cat. No. 441)

Notes
<p>If your CP65 does not contain the Cat. No. 441 Surround Equalizer and Subwoofer Card, skip this paragraph and go directly to page 5-42, Adjustment of Surround Delay. The CP65 will function without the Cat. No. 441 card, but the surround frequency response cannot be equalized.</p> <p>The surround equalizer on the Cat. No. 441 card consists of:</p> <ul style="list-style-type: none"> • A parametric mid-band section with variable cut, bandwidth, and center frequency. • Shelving type Bass and Treble controls. <p>All connections established in the previous procedure still apply to the surround equalization alignment. Confirm that the microphone is in the position defined on page 5.6. Ensure that format 04 is selected.</p> <p>Note: The Cat. No. 441 can be configured for either Mono or Stereo surround operation using link J3 (See page 2-5 for details). If Mono operation is selected then an identical signal will be fed to both Ls and Rs outputs in all formats. If only one power amplifier is to be used for the surround channel then the Ls should be used. If more than one surround amplifier is to be used, both outputs may be used to feed, for example, balcony and ground floor. The separate level controls and equalizers may then be used to compensate for differences caused by the different acoustic environments of the two areas. If stereo operation is selected a stereo surround signal will be fed to the surround channels when format 10, Dolby Stereo SR•D is selected.</p>
<p>If the surround speakers are wired for stereo operation or both surround outputs are in use switch off (or disconnect the input to) the right surround amplifier or amplifiers.</p>
<p>Turn on the S switch on the Cat. No. 85C pink noise generator. Be sure that format 04 is selected.</p> <p>Adjust the Ls (left surround) gain control on the Cat. No. 242 B-Chain card for a sound pressure level of approximately 85 dBC in the theatre. If only one surround output is used set the level to 88 dBC.</p>

B-Chain Alignment Procedures

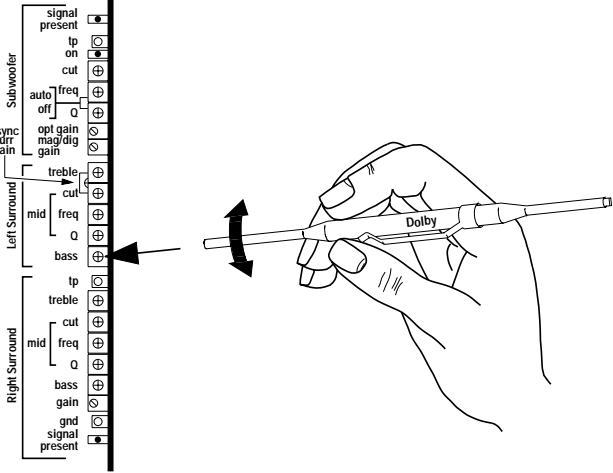
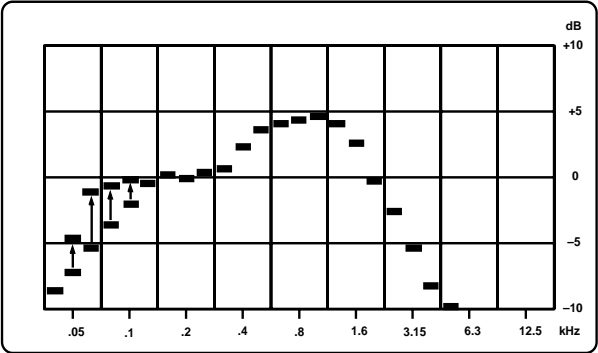
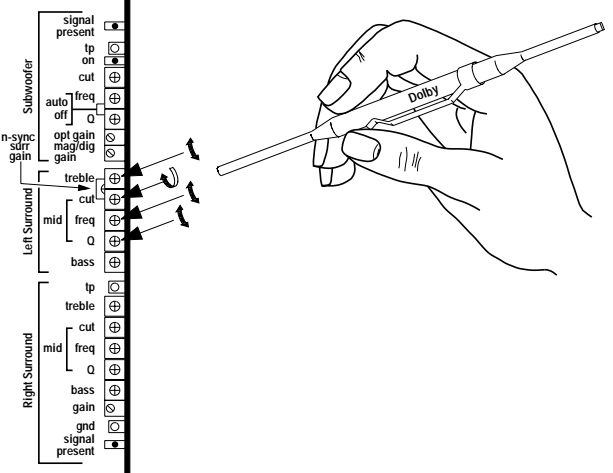
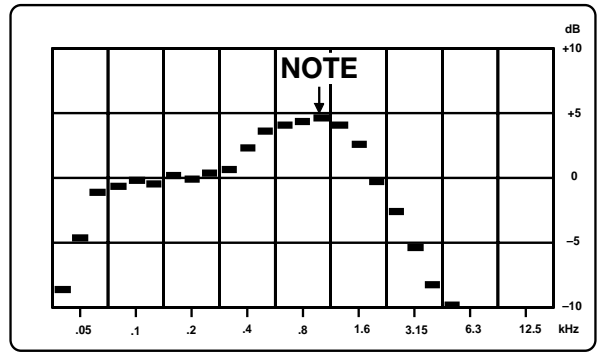
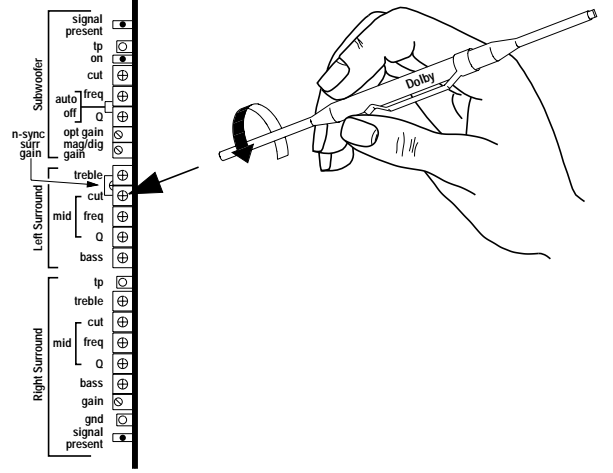
e. Surround Equalization Alignment (Cat. No. 441)

Step No.	Action	Indication
3	<p>Cat. No. 441</p> 	
4	<p>Cat. No. 441</p> 	
5	<p>Cat. No. 441</p> 	

B-Chain Alignment Procedures

e. Surround Equalization Alignment (Cat. No. 441)

Notes
<p>Adjust the Left Surround bass control on the Cat. No. 441 card for as flat as possible low frequency response on the RTA. Use caution when adjusting the bass control; many surround loudspeaker systems are deficient in their low frequency response. Attempts to boost the output of such system beyond their capabilities simply wastes amplifier power and can result in distortion and possibly damage to the surround loudspeakers.</p>
<p>Adjust the Left Surround treble control to its mid point, so that it provides neither cut nor boost.</p>
<p>Adjust the mid frequency controls as follows: Turn the Cut control fully clockwise (CW). Set the Q and freq controls to their mid positions.</p>
<p>Note the position of the center of the highest frequency peak in the 350 Hz to 3 kHz region on the analyzer screen.</p>
<p>Turn the Cut control fully counterclockwise and note the position of the notch produced by the equalizer.</p>

B-Chain Alignment Procedures

e. Surround Equalization Alignment (Cat. No. 441)

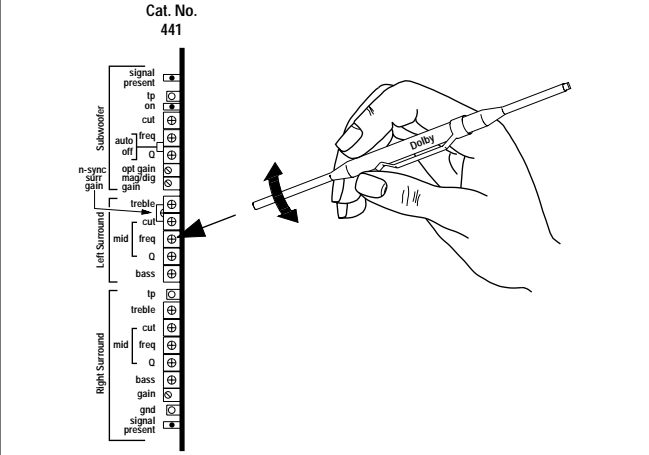
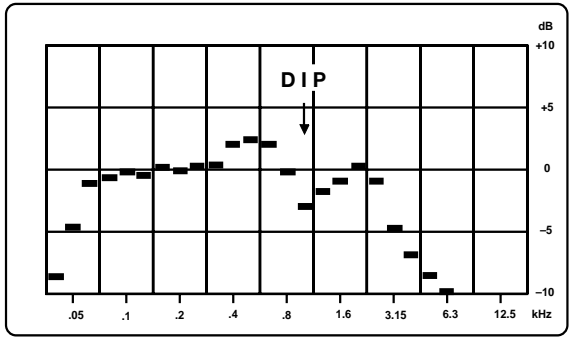
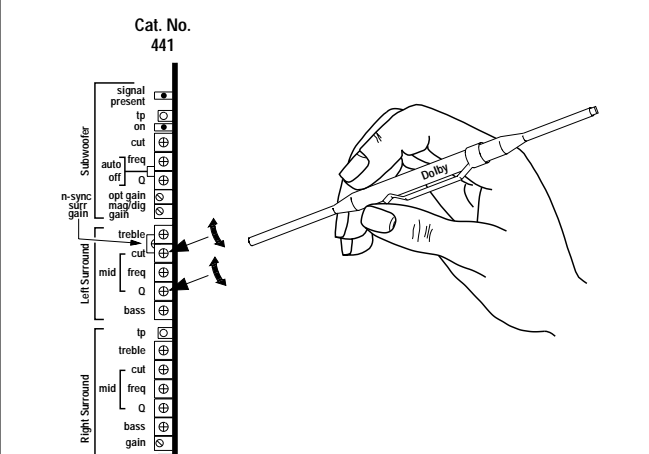
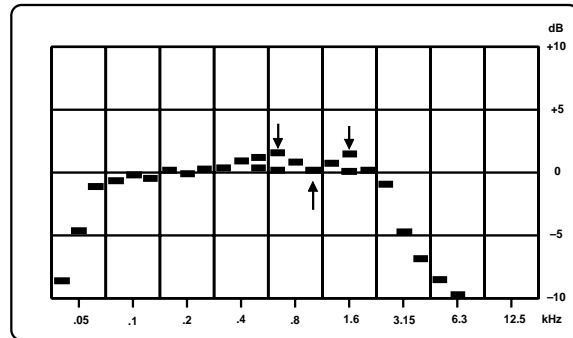
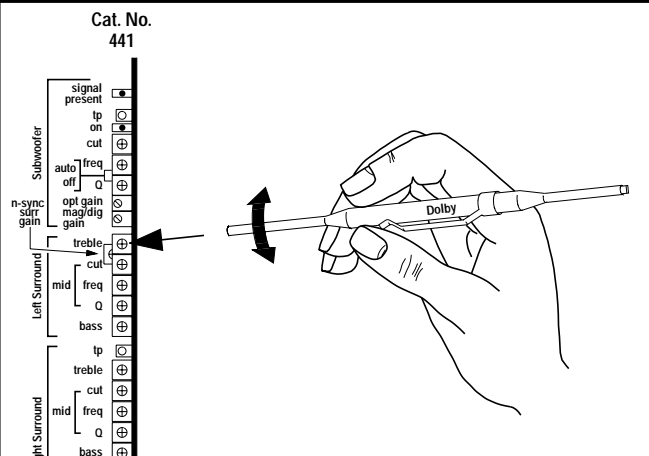
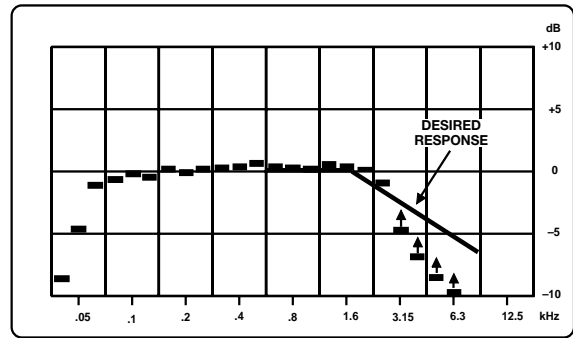
Step No.	Action	Indication
6	<p>Cat. No. 441</p> 	
7	<p>Cat. No. 441</p> 	
8	<p>Cat. No. 441</p> 	
9	<p>REPEAT 6 → 8</p>	

B-Chain Alignment Procedures

e. Surround Equalization Alignment (Cat. No. 441)

Notes
<p>Turn the freq control so that the notch is located over the peak noted in the previous step.</p>
<p>Adjust the Cut and Q controls for the flattest response in this part of the spectrum.</p>
<p>Adjust the treble control on the Cat. No. 441 card for the best approximation to the desired response shown.</p>
<p>The treble and mid equalizer controls interact. Repeat the adjustments until no further adjustment is required and you have attained the optimum frequency response.</p>

B-Chain Alignment Procedures

e. Surround Equalization Alignment (Cat. No. 441)

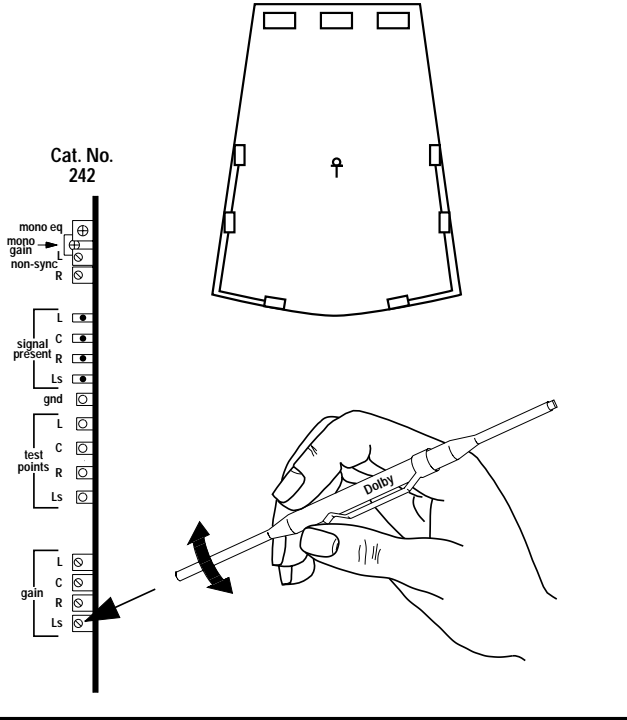
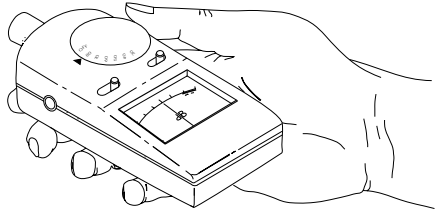
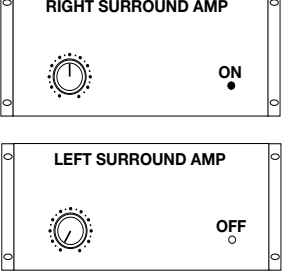
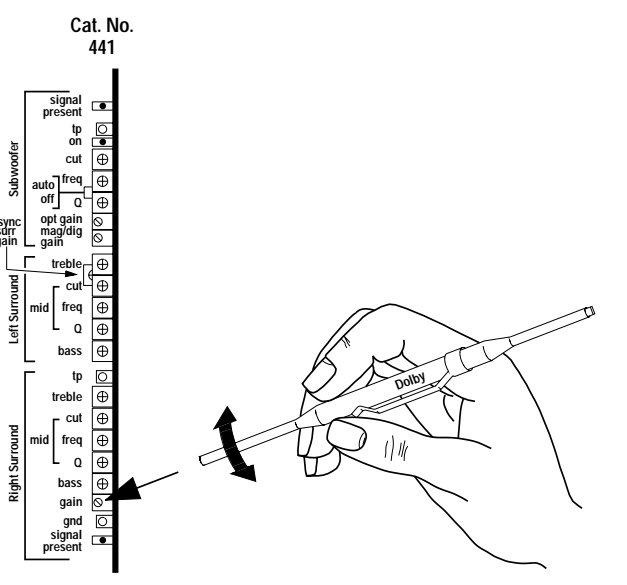
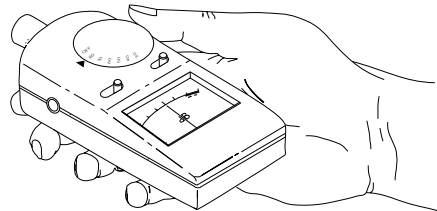
Step No.	Action	Indication
10		<p>MONO SURROUND STEREO SURROUND</p> <p>88 dBC 85 dBC</p> 
11		
12		<p>85 dBC</p> 
13	<p>REPEAT 3 → 10</p>	



B-Chain Alignment Procedures

e. Surround Equalization Alignment (Cat. No. 441)

Notes
<p>Adjust the Ls (Left surround) gain control on the Cat. No. 242 B-Chain card for a sound pressure level of 85 dBC (or 88 dBC if only one surround output is to be used).</p>
<p>If the surround speakers are wired for stereo operation or both surround outputs are in use, switch on (or reconnect the input to) the right surround amplifier or amplifiers. Switch off (or disconnect the input to) the Left surround amplifier or amplifiers.</p>
<p>With the microphone still located at the center of the theatre, adjust the Right Surround gain control on the Cat. No. 441 surround and subwoofer card for a sound pressure level of 85 dBC.</p>
<p>Repeat Steps 3 through 10 using the Right Surround pots on the Cat. No. 441 card. NOTE: When you reach Step 10 remember that the right surround gain control is located on the Cat. No. 441 board.</p>

B-Chain Alignment Procedures

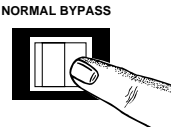
e. Surround Equalization Alignment (Cat. No. 441)

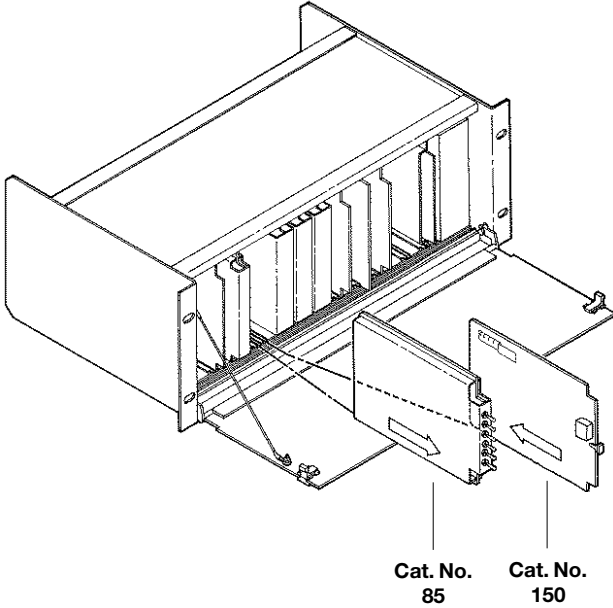
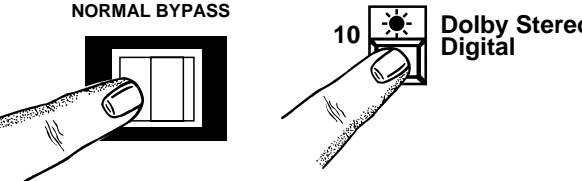
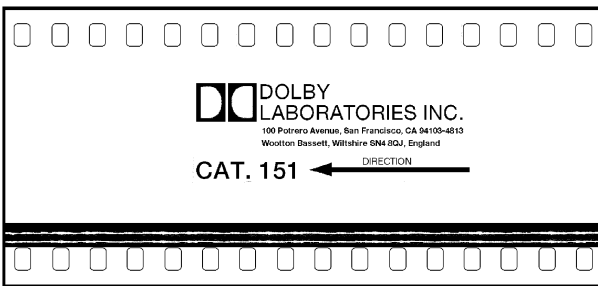
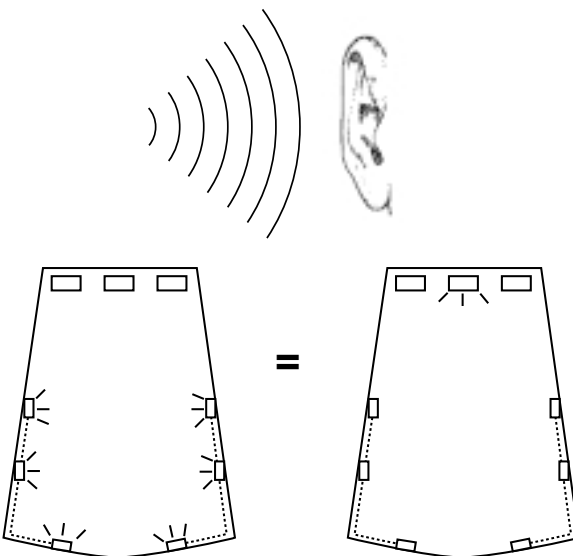
Step No.	Action	Indication
14		
15		
16		
17		

B-Chain Alignment Procedures

e. Surround Equalization Alignment (Cat. No. 441)

Notes
<p>Open the CP65 and place the NORMAL/BYPASS switch in the BYPASS position.</p>
<p>Remove the Cat. No. 85C card and re-install the Cat. No. 150 card.</p>
<p>Restore the BYPASS/NORMAL switch to the NORMAL position. Confirm that format 04 Dolby Stereo A-Type is selected.</p>
<p>Thread and play the Cat. No. 151 stereo optical surround level film. Check the sound by walking around the theatre. The surround and center channels should sound equally loud at most locations and left and right surround channels should sound equally loud and have similar frequency response in the center of the theatre. If necessary, readjust the left and right surround gains until you are satisfied with the surround-to-front center balance. A large change in the gain setting should be unnecessary.</p>

B-Chain Alignment Procedures

f. Adjustment of Surround Delay

The CP65 incorporates a delay line in the surround channel to ensure that sound from the rear of the theatre arrives at the listeners' ears approximately 20 milliseconds after the arrival of sound from the front speakers. The delay is set into the Cat. No. 150 card via a thumbwheel switch by using the following formula:

1. The distance between a rear seat and the nearest surround loudspeaker, in feet, is estimated. If the metric system is used, convert the distance from meters to feet by multiplying by three (3).
2. The distance from this seat to the front loudspeakers is estimated, in feet. If the metric system is used, multiply the distance by three (3) to convert distance from meters to feet.
3. Subtract the distance in 1 above from the distance in 2 above.
4. Add 20 to the difference in 3. above to obtain the delay time, in milliseconds.

Determine the Cat. No. 150 card thumbwheel switch setting (delay line setting) from the table below.

Delay Time (msec)	Thumbwheel Switch Setting
30	1
40	2
50	3
60	4
70	5
80	6
90	7
100	8
110	9
120	10
130	11
140	12
150	13

For example:

The selected seat is 10 feet (3.3 meters) from the surround speakers.

The selected seat is 80 feet (26.7 meters) from the front speakers.

The delay is set for $(80-10) + 20 = 90$ milliseconds — switch position 7.

B-Chain Alignment Procedures

f. Adjustment of Surround Delay

You can verify that the delay setting is acceptable by listening to a familiar Dolby Stereo film which ideally contains both center channel dialogue and some discernable surround sound. The Dolby Cat. No. 251 "*Jiffy*" film serves excellently for this purpose. If a stereo film is not available, the delay time can be checked with a mono film if the film is played in format 04 Dolby stereo optical with surround. Before you set the delay time, set the individual level adjustments for each channel because the subjective effects of channel level and delay time interact somewhat. Make certain all speakers are ON for this test.

While the film is playing, walk around the theatre and carefully listen to the surround speakers when there is center channel dialogue. The dialogue should appear to be coming from the screen with no significant dialogue coming from the surround speakers.

If you hear discernable dialogue from the surround speakers, the delay time was probably set too long.

If you hear an objectionable amount of dialogue from the surround speakers, which persists regardless of the delay time setting, there is probably severe gain or azimuth error in the system. Recheck both the Dolby level and the A-chain alignment of the optical system.

In many films, the surround information is intended for subtle effects and may provide only a low-level ambience. If the surround level and delay time have been adjusted as previously described, the surround information will be at the level desired by the film director. Do not be tempted to increase the surround level because the effect desired by the film production team may be impaired or destroyed.

B-Chain Alignment Procedures

g. Adjustment of Bypass Gain

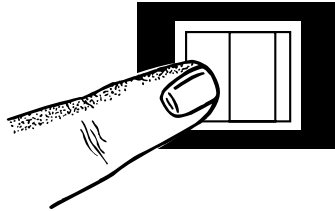
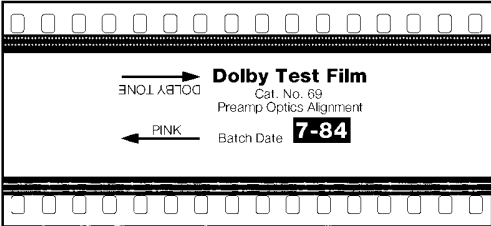
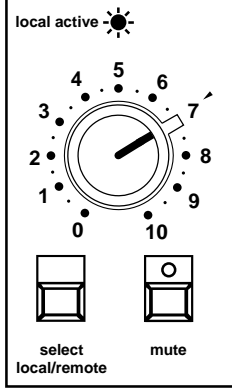
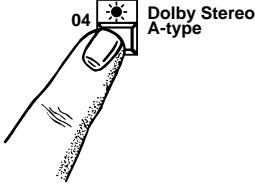
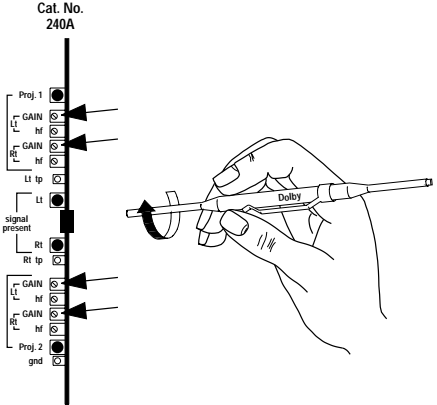
Step No.	Action	Indication
1	<p>NORMAL BYPASS</p> 	
2	<p>Dolby Tone</p>  <p>Pink Noise</p>	
3		
4		<p>xx dBC</p> 



B-Chain Alignment Procedures

g. Adjustment of Bypass Gain

Notes
<p>This section of the alignment procedure covers the adjustment of the gain that is in effect when the CP65 is switched from NORMAL to BYPASS.</p> <p>Verify that the NORMAL/BYPASS switch is in the NORMAL position.</p>
<p>Thread and play the Cat. No. 69 Pink Noise film loop on the projector.</p>
<p>Check that the local FADER is selected — the local active LED on the CP65 is lit. If necessary, select the local FADER by pressing the select local/remote switch.</p>
<p>Set the FADER to the 7 setting.</p>
<p>Press the format 04 Dolby Stereo A-type switch. Measure and note the SPL (sound pressure level) in the theatre.</p>

B-Chain Alignment Procedures

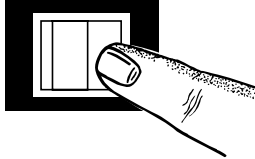
g. Adjustment of Bypass Gain

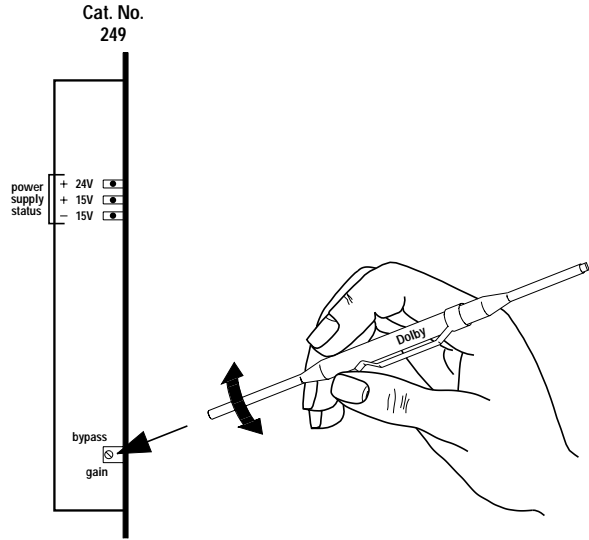
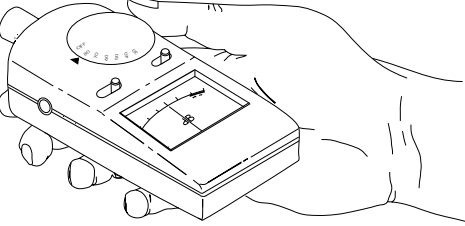
Step No.	Action	Indication
5	<p>NORMAL BYPASS</p> 	<p>bypass  (switch behind panel)</p>
6	<p>Cat. No. 249</p> 	<p>FROM 4 $\frac{xx \text{ dBC} - 3 \text{ dB}}{yy \text{ dBC}}$</p> 
7		

B-Chain Alignment Procedures

g. Adjustment of Bypass Gain

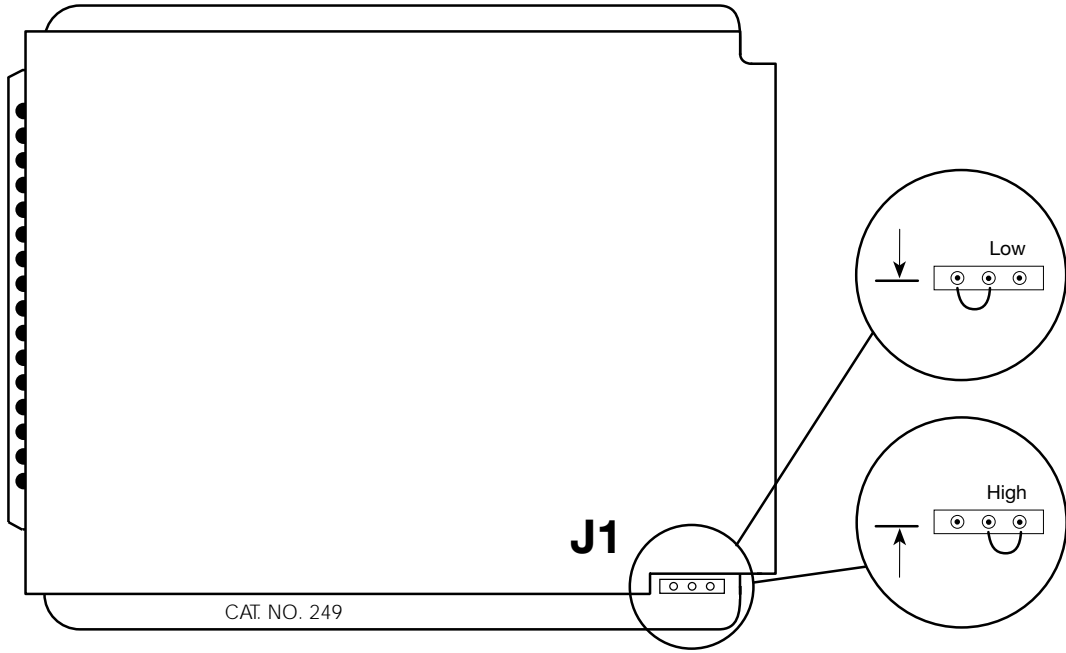
Notes
<p>Place the NORMAL/BYPASS switch in the BYPASS position.</p>
<p>Adjust the bypass gain control on the Cat. No. 249 Power Supply card for a SPL 3 dB less than you noted in the NORMAL mode at Step 4. If this level cannot be achieved via the control, disconnect the CP65 from AC power, remove the Cat. No. 249 card, switch the J1 jumper from the Low to the Hi position, reinstall the Cat. No. 249 card, reconnect AC power to the CP65, and readjust the SPL to the required level.</p>

<p>At this point, you can disconnect all external equipment from the CP65. The remainder of the alignment procedure does not require measuring instruments.</p>

B-Chain Alignment Procedures

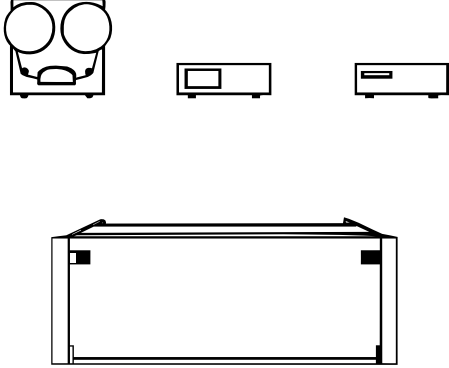
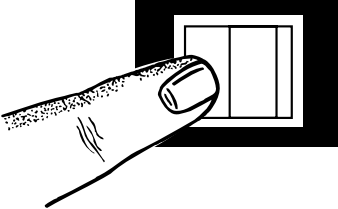
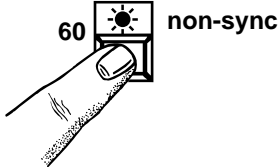
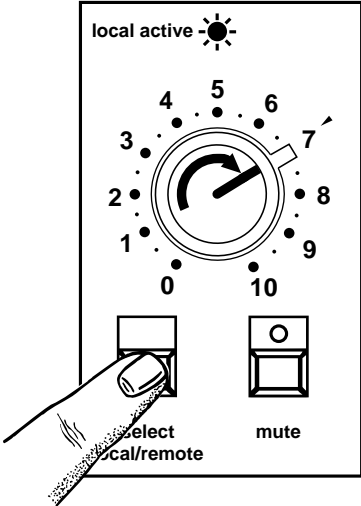
h. Adjustment of Non-sync Gain

Step No.	Action	Indication
1		
2	NORMAL BYPASS 	
3		
4		

B-Chain Alignment Procedures

h. Adjustment of Non-sync Gain

Notes
Connect a cassette deck or CD player to the from non sync terminals on terminal block TB1 on the backplane of the CP65.
Place the NORMAL/BYPASS switch in the NORMAL position.
Press the format 60 non sync switch.
Check that the local FADER is selected — the local active LED on the CP65 is lit. If necessary, select the local FADER by pressing the select local/remote switch.
Set the FADER to the 7 setting.

B-Chain Alignment Procedures

h. Adjustment of Non-sync Gain

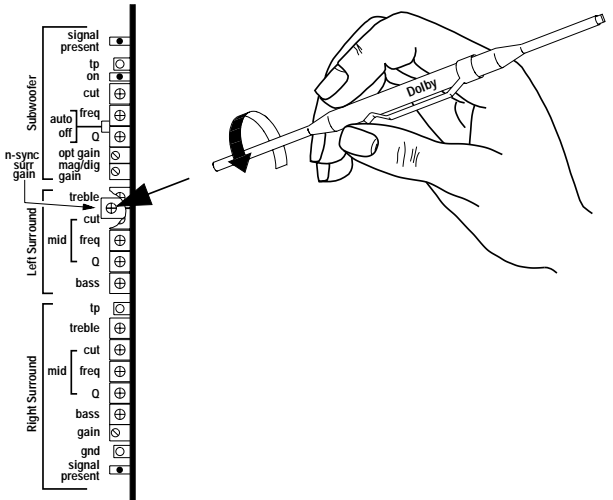
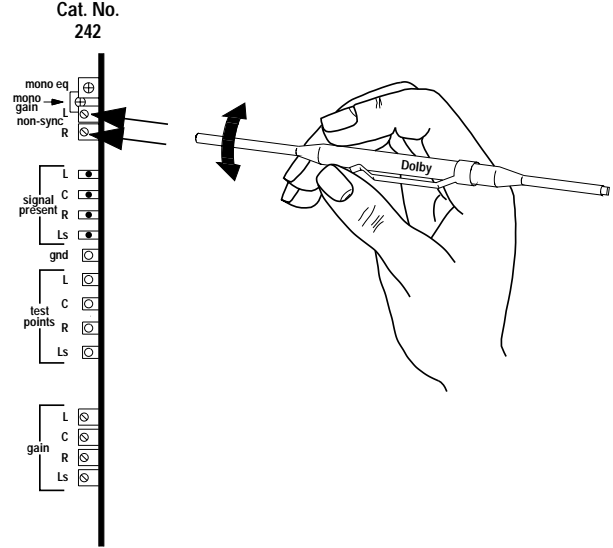
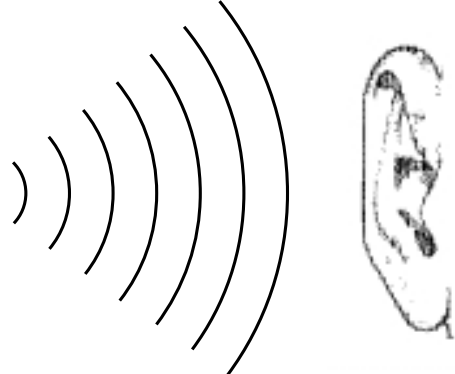
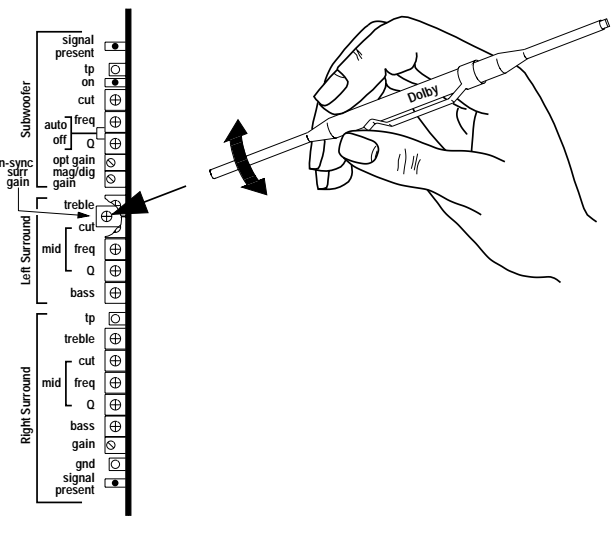
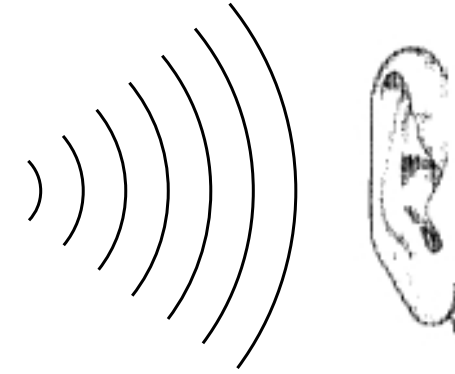
Step No.	Action	Indication
5	<p>Cat. No. 441</p>  <p>Cat. No. 242</p> 	
6	<p>Cat. No. 441</p> 	



B-Chain Alignment Procedures

h. Adjustment of Non-sync Gain

Notes
<p>Turn the Non sync surround gain on the Cat. No. 441 fully counterclockwise.</p>
<p>Play a cassette or CD on the non-sync device and adjust the non-sync L (left) and non-sync R (right) controls on the Cat. No. 242 B-Chain card for the desired level in the theatre. If possible, select a recording that has a natural ambience such as an orchestral work.</p>
<p>Adjust the Non sync surround gain control on the Cat. No. 441 (if fitted) for the desired surround level in the auditorium. This control is not present on a Cat. No. 241.</p>

B-Chain Alignment Procedures

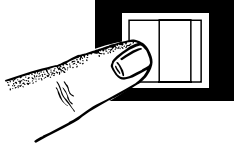
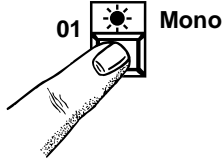
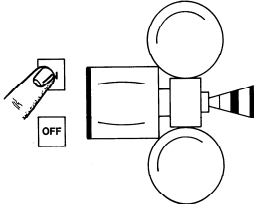
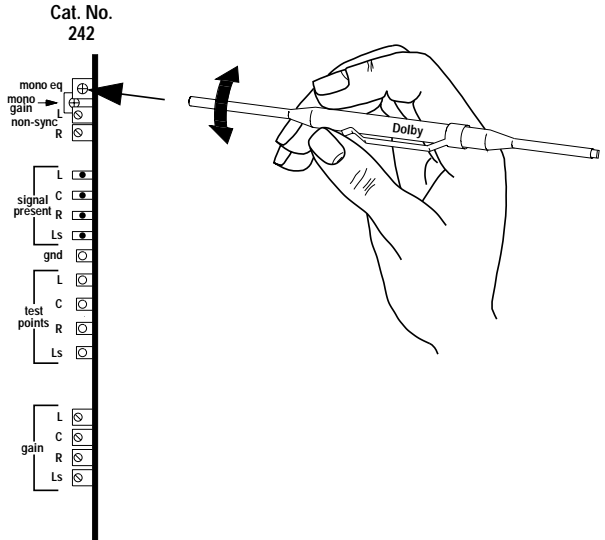
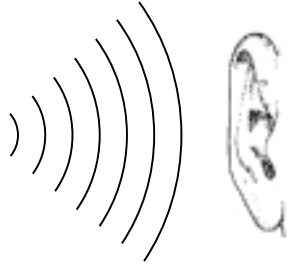
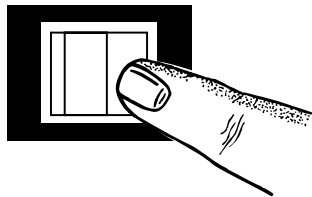
i. Adjustment of Mono Gain and Equalization

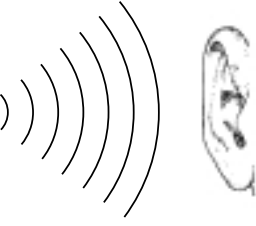
Step No.	Action	Indication
1	<p>NORMAL BYPASS</p> 	
2		
3		
4	<p>Cat. No. 242</p>  	
5	<p>REPEAT PAGE 5-20 STEP 2</p>	
6	<p>NORMAL BYPASS</p>   	
7		





B-Chain Alignment Procedures

i. Adjustment of Mono Gain and Equalization

Notes
<p>Verify that the NORMAL/BYPASS switch is in the NORMAL position.</p>
<p>Select format 01 mono.</p>
<p>Thread and play a mono film. It is best to play a film familiar to you.</p>
<p>The mono eq control on the Cat. No. 242 card affects high frequencies and should generally be left in the midpoint of its range to provide the "Academy" high-frequency playback standard. Turn it to the midpoint of the range and listen to the film. If necessary, adjust the control for pleasing sound.</p>
<p>While the film is running, repeat the mono gain adjustment (page 5.20) with the front panel FADER set to 7.</p>
<p>While the film is running, place the NORMAL/BYPASS switch in the BYPASS position. Verify that the sound level is acceptable in BYPASS, and that the volume remains nearly the same as it was in NORMAL.</p>
<p>Remove the mono film from the projector.</p>

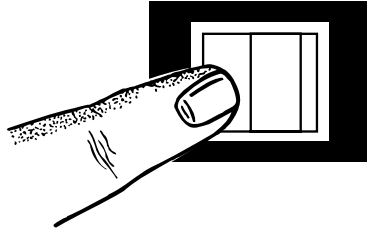
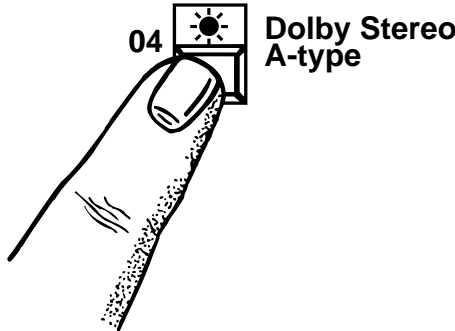
B-Chain Alignment Procedures

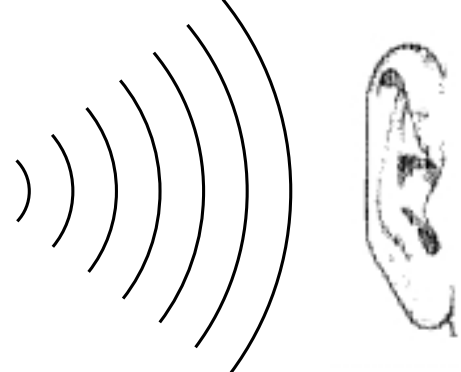
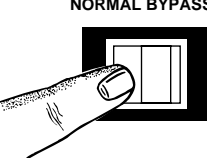
j. Final Checks

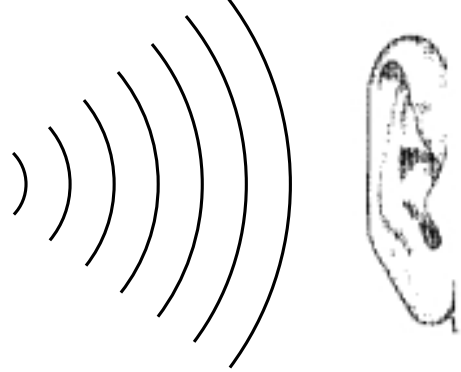
Step No.	Action	Indication
1	<p>NORMAL BYPASS</p> 	
2		
3		
4	 	

B-Chain Alignment Procedures

j. Final Checks

Notes
<p>Verify that the NORMAL/BYPASS switch is in the NORMAL position.</p>
<p>Press the format 04 Dolby Stereo A-type switch.</p>
<p>Thread and play the Dolby Cat. No. 251 "Jiffy" test film, if available, for a quick check of the system alignment. This film contains a series of tests, each of which is described by a male or female voice and is supplemented by captions on the screen to help identify the causes of sound problems. Visual checks are also included to assist in identifying some picture projection problems.</p>
<p>Remove the "Jiffy" film, return to NORMAL</p> <p>Play the Dolby Cat. No. 351 "listen . . ." film on the newly aligned system. The film consists of a wide variety of short scenes — both live action and animated. Each scene was selected to demonstrate different aspects of stereo sound. Evaluate the quality of the sound. If problems occur, contact the technical staff at Dolby Laboratories.</p>

SECTION 6
REFERENCE DIAGRAM

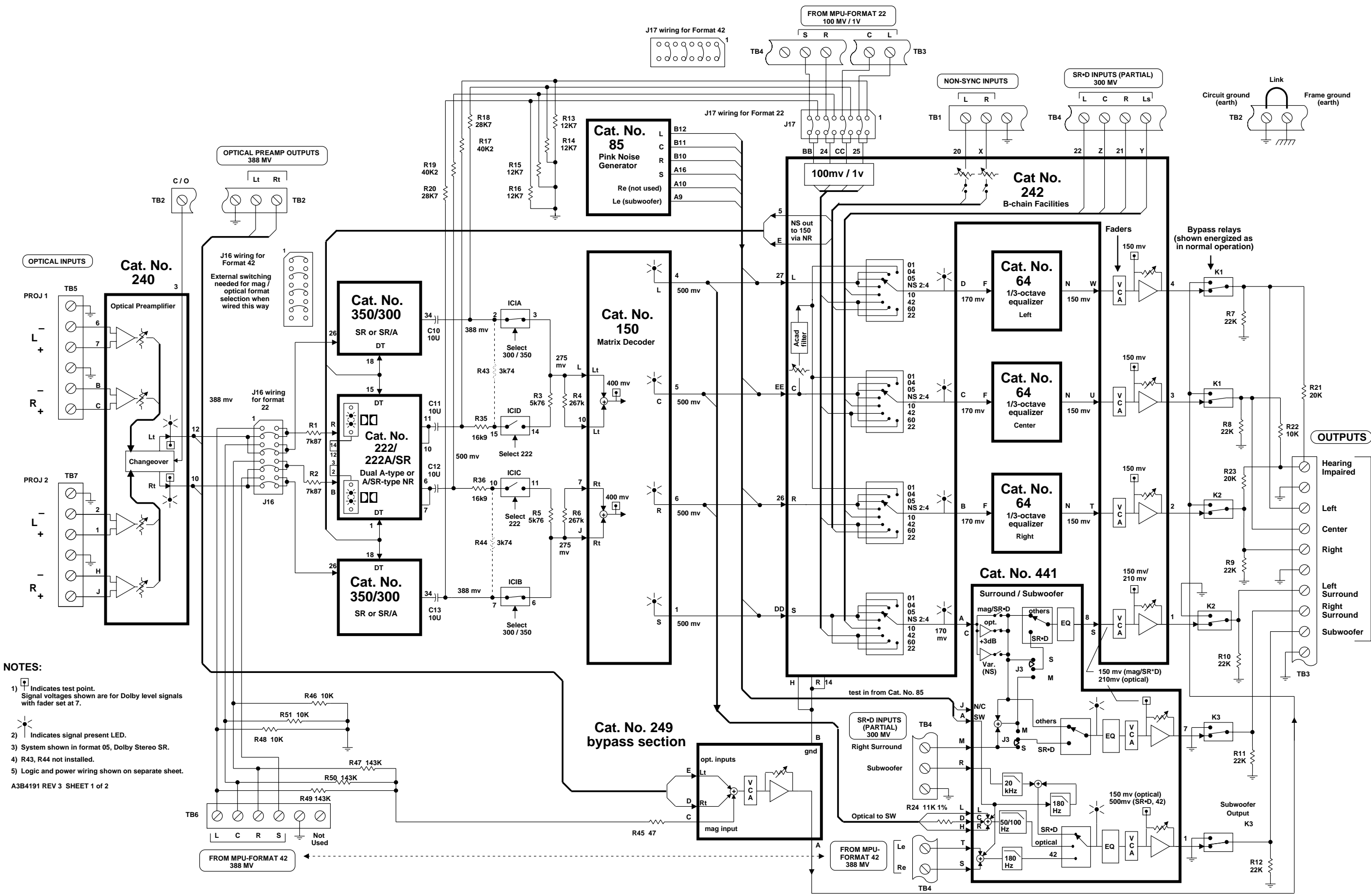

- NOTES:**
- 1) Indicates test point. Signal voltages shown are for Dolby level signals with fader set at 7.
 - 2) Indicates signal present LED.
 - 3) System shown in format 05, Dolby Stereo SR.
 - 4) R43, R44 not installed.
 - 5) Logic and power wiring shown on separate sheet.
- A3B4191 REV 3 SHEET 1 of 2

CP65 SIGNAL PATH BLOCK DIAGRAM

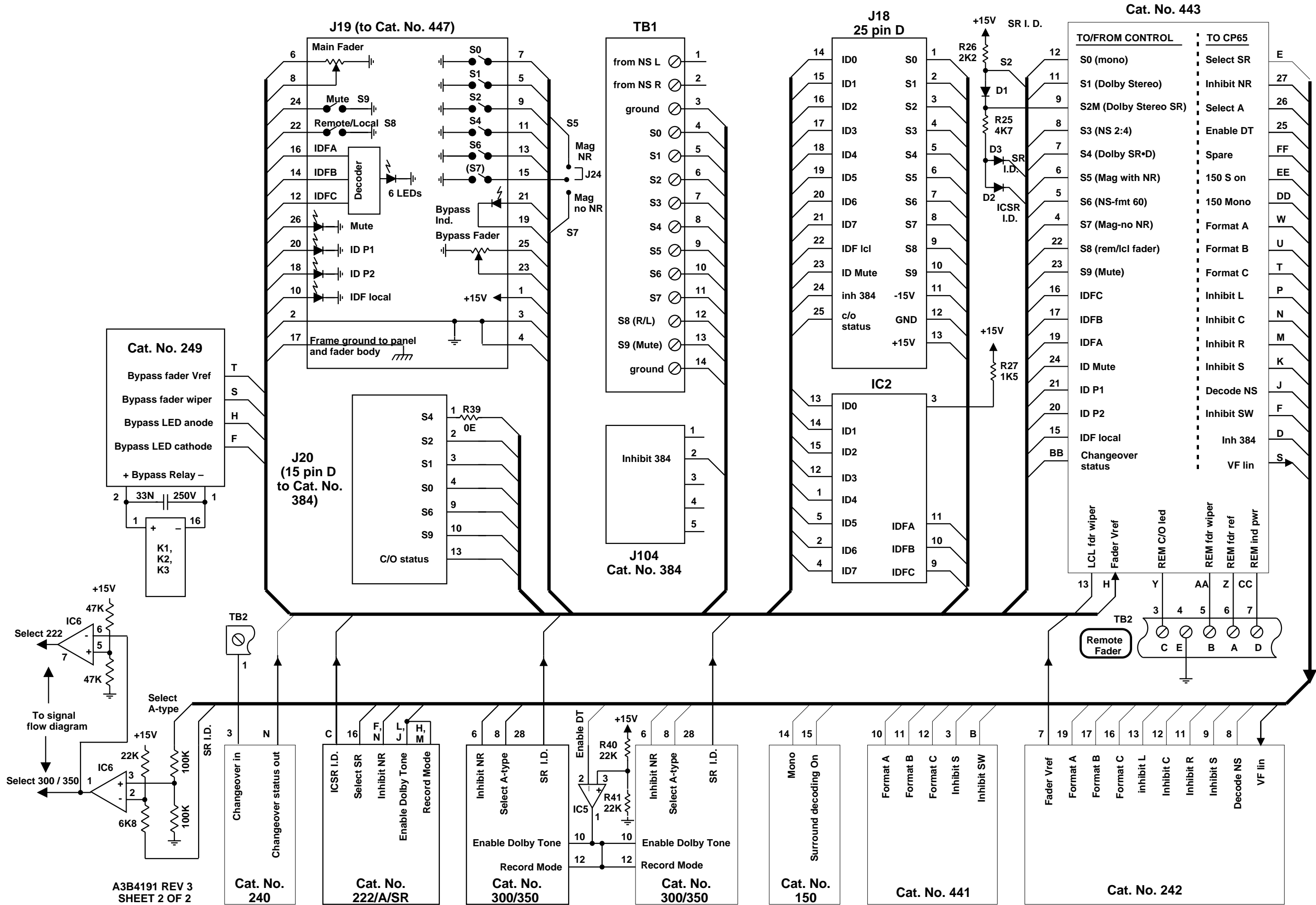

Cat. No. 222 Dual Noise Reduction Module

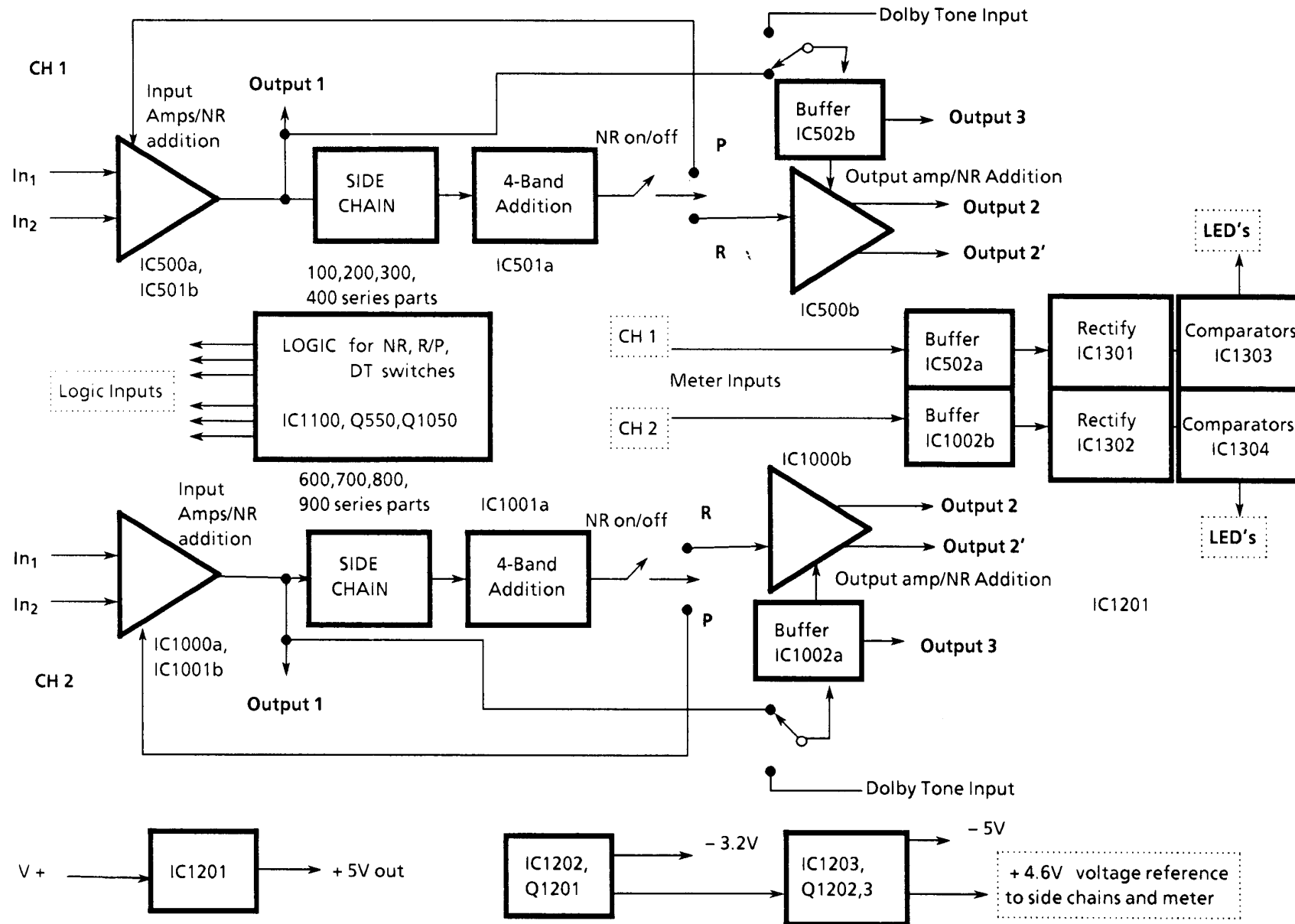

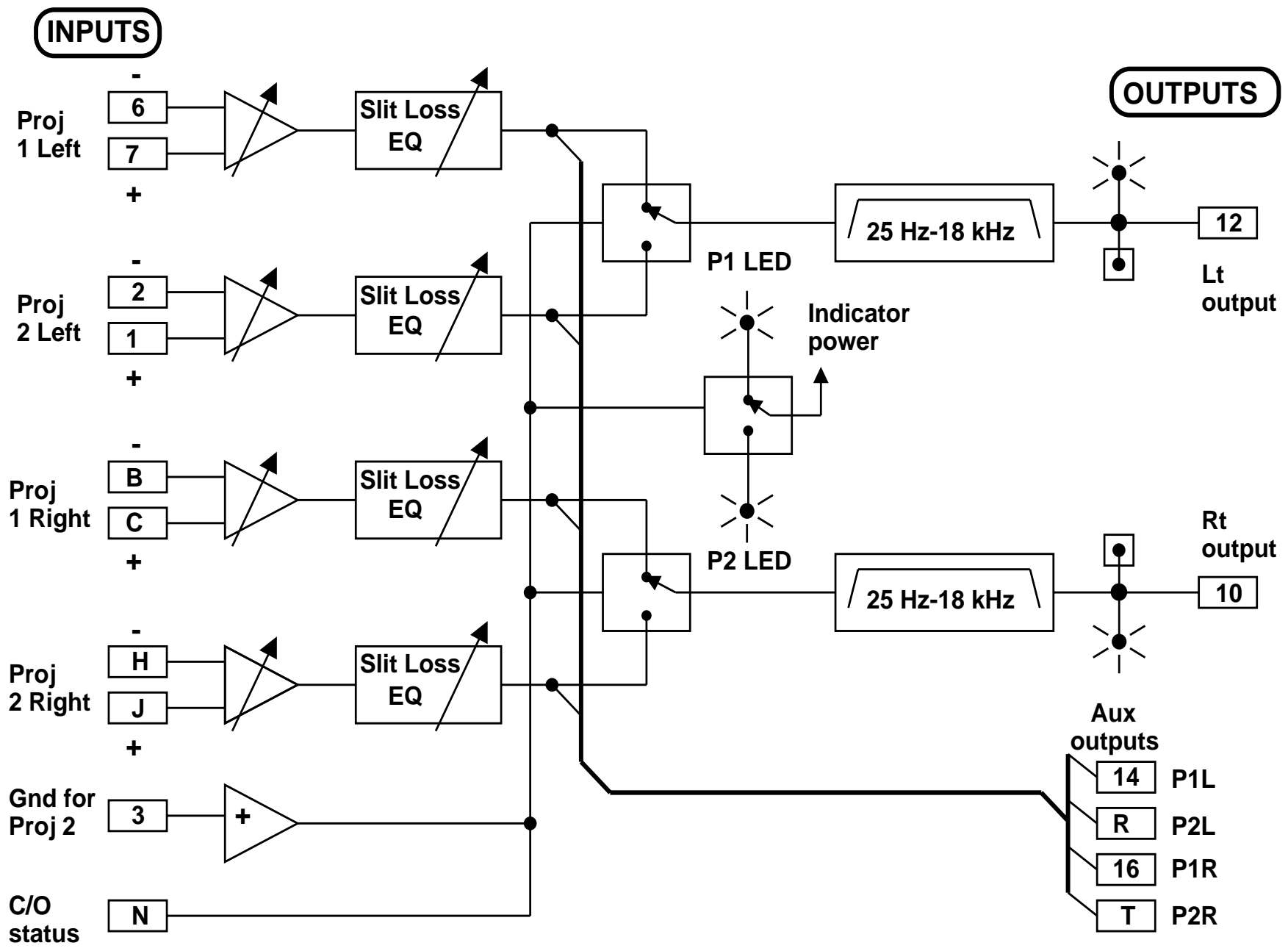

Cat. No. 241 Optical Bass Extension and Surround Equalizer Card

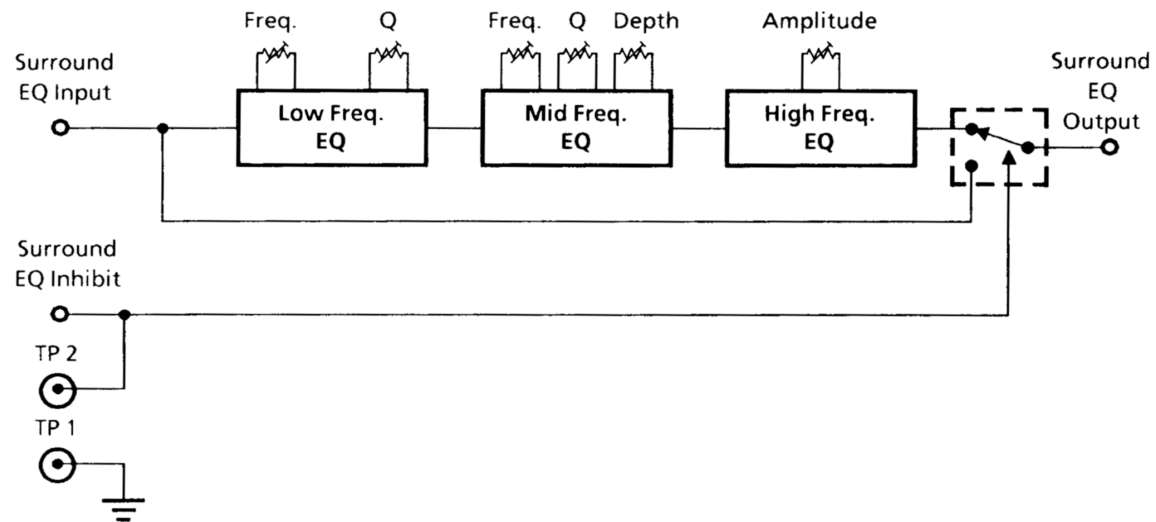
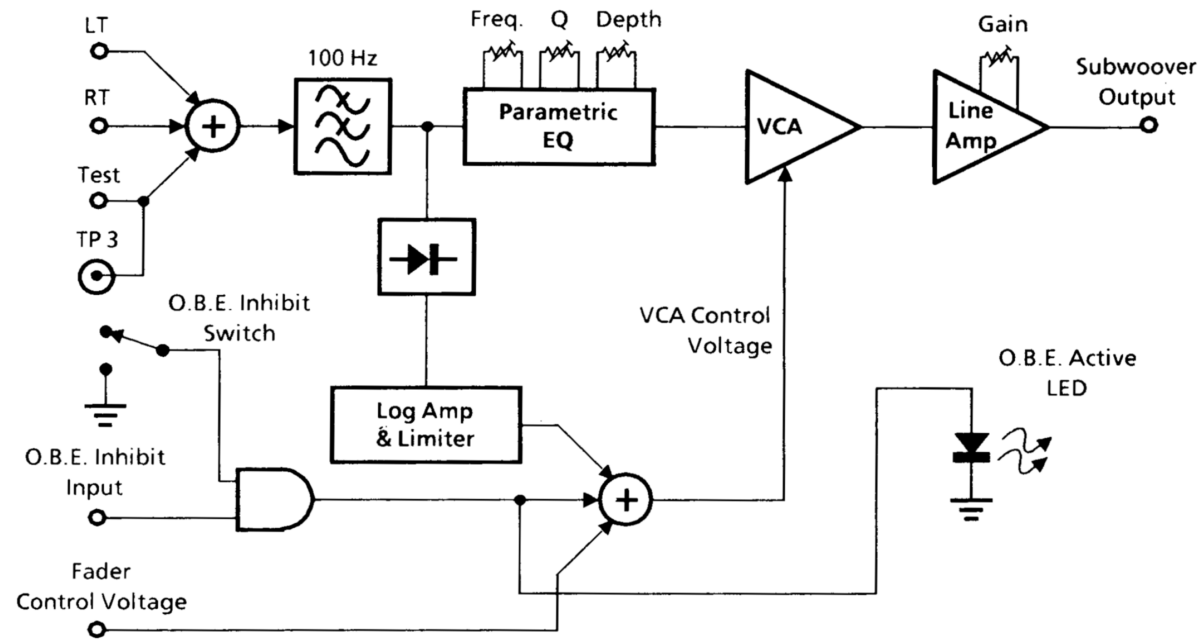

Cat. No. 242 B-Chain Facilities Card

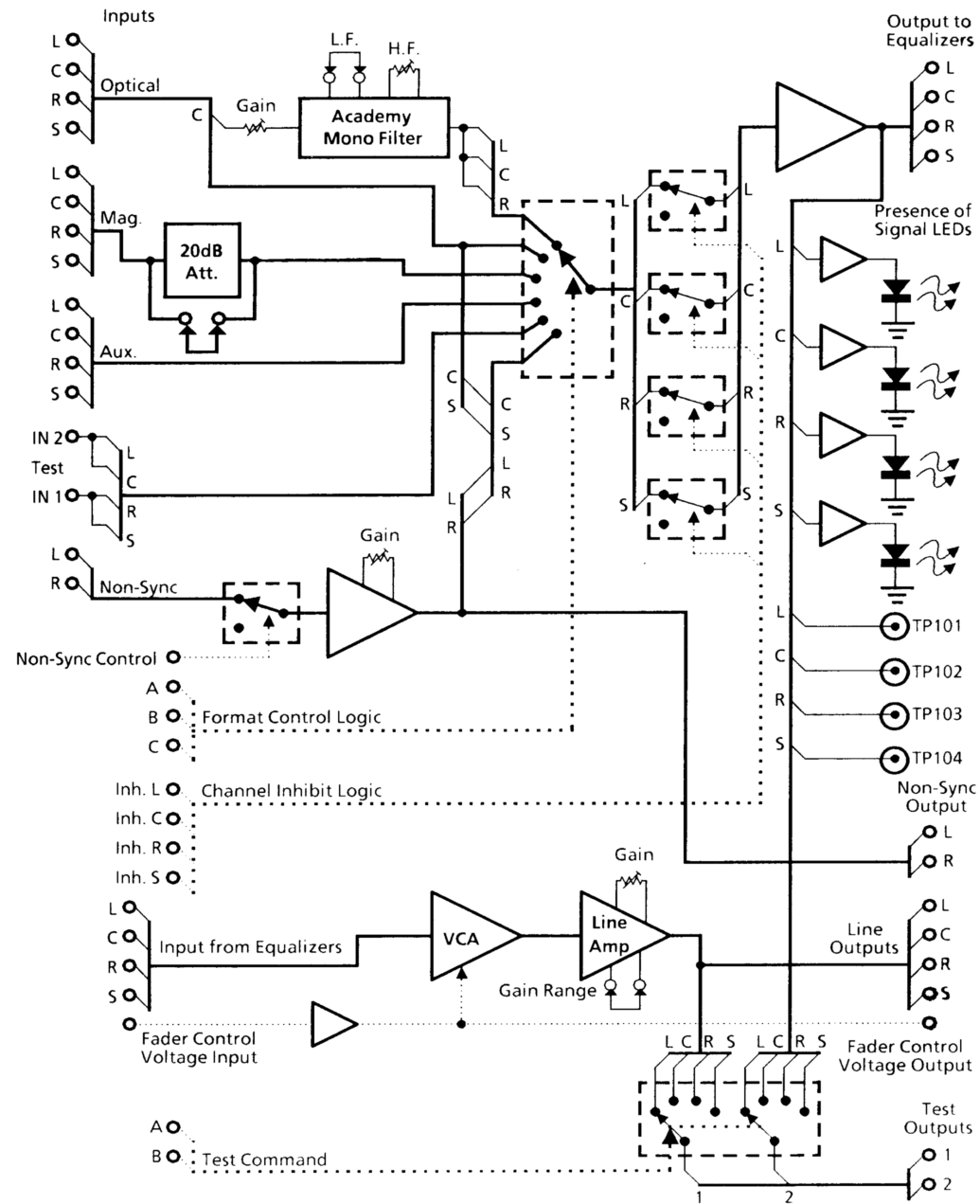

Cat. No. 249 Power Supply Card

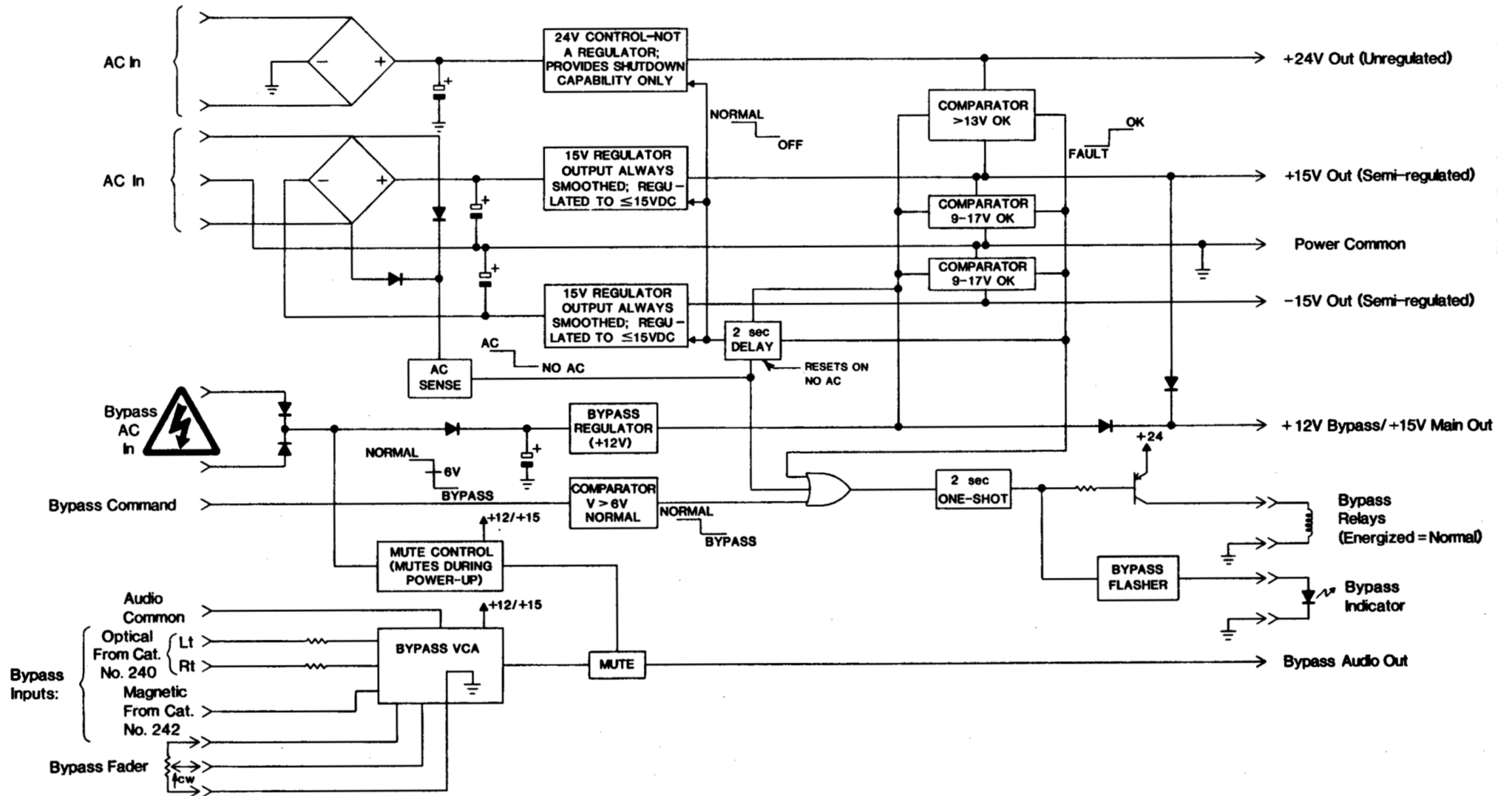

Cat. No. 259 Transformer Module

AC MAINS V ₆ ⊕	VOLTAGE SELECTOR SWITCH S2 INTERNAL CONNECTIONS	
	SWITCH POSITION	PINS SHORTED
85 - 110	100V	7 TO 4 3 TO 4 2 TO 1
102 - 132	120V	7 TO 6 5 TO 4 2 TO 1 3 TO 4
119 - 154	140V	5 TO 6 3 TO 4 2 TO 1
170 - 220	200V	7 TO 4 2 TO 3
187 - 242	220V	7 TO 6 5 TO 4 2 TO 3
204 - 264	240V	5 TO 6 2 TO 3

MAINS SETTING	FUSE RATING	/250V	SIZE
100/120/140V	1.25A	SLOW-BLOW	0.25 x 1.25"
200/220/240V	T630mA	TIME-LAG	5 x 20mm

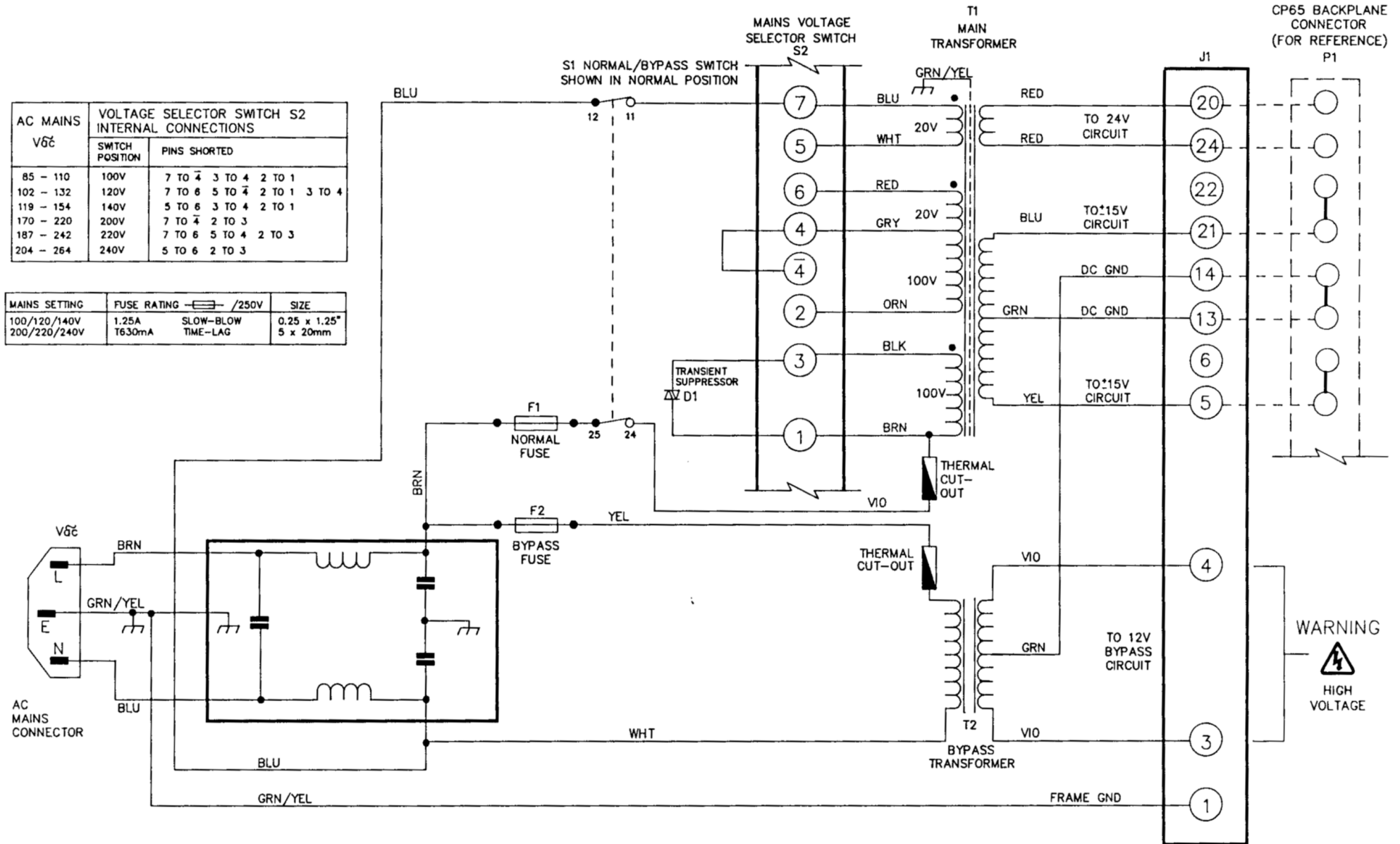

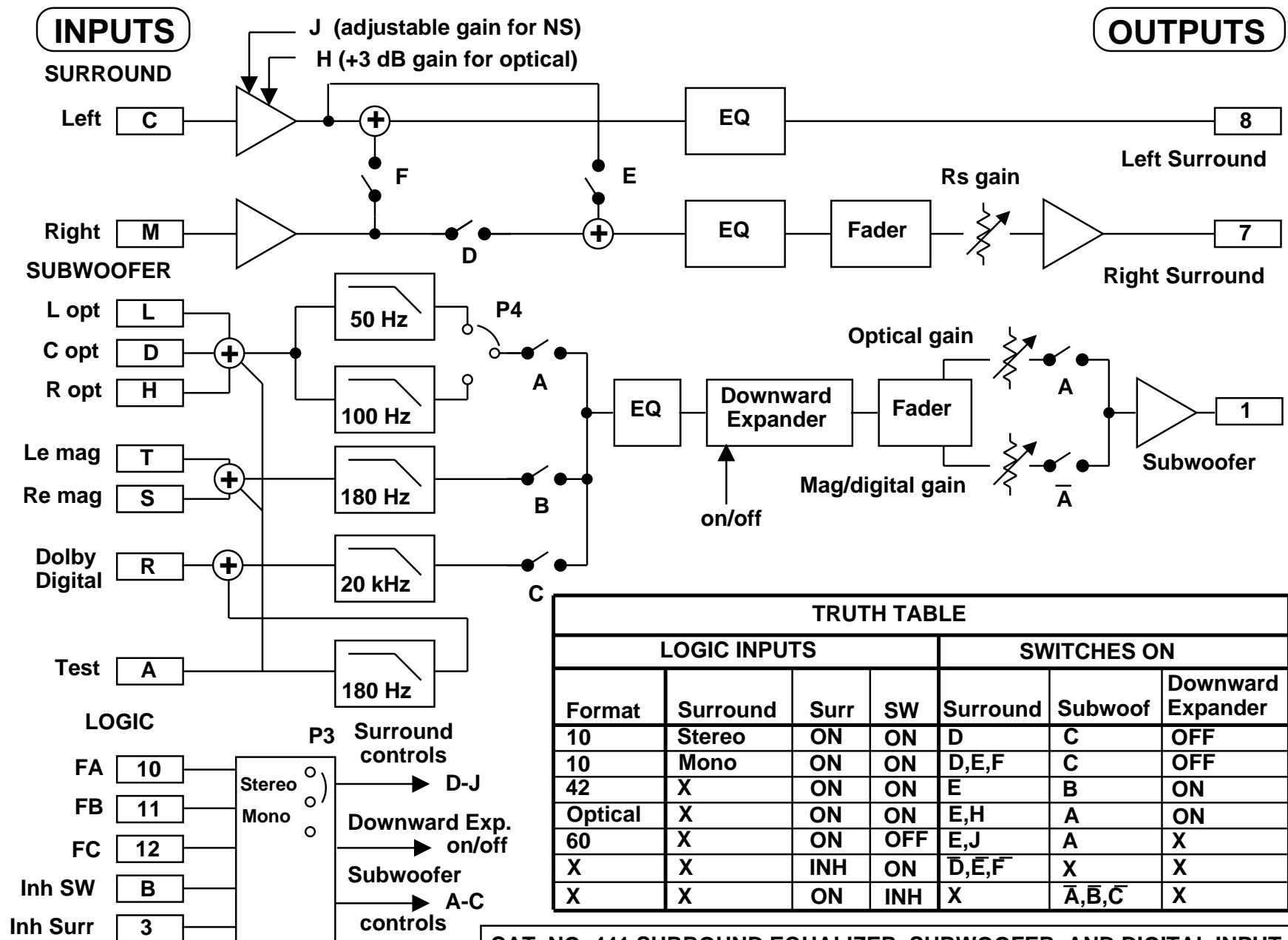

CAT. NO. 441 SURROUND EQUALIZER, SUBWOOFER, AND DIGITAL INPUT

Cat. No. 443 Control Logic Card

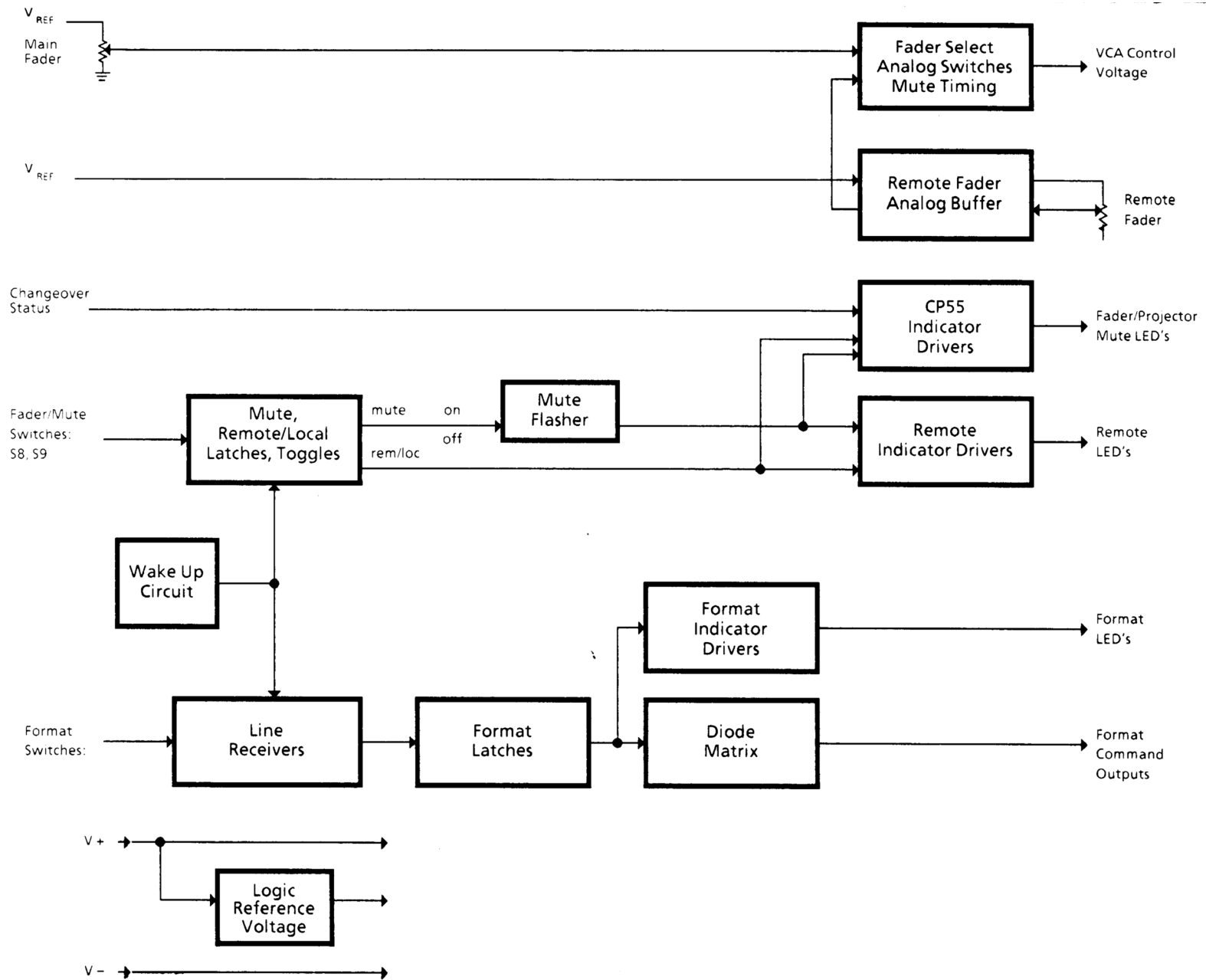

CP65 POWER DISTRIBUTION TABLE						
Cat. No.	+24V	+15V	GND	-15V	+12B/ +15M	DIG GND
240	-----	5,E	9,K	(13,P)	4,D	-----
222	-----	5,E	9,K	13,P	-----	-----
300/350	-----	1,2	23,24	39,40	-----	-----
150	16,T	3,C	9,K	13,P	-----	-----
64	-----	5,E	9,K	13,P	-----	-----
441	-----	5,E	9,K	13,P	-----	-----
242	-----	10,L	14,R	18,V	-----	23,AA
443	-----	10,L	14,R	18,V	-----	3,C
249	Z,AA	L,K	P,R	V,W	4,5	M,N
IC1	-----	12,13	5	4	-----	-----
IC2	-----	16	6,7,8	-----	-----	-----
85	A23,B23	A3,A4 B3,B4, A8	A13,14 B13,14, 19	A17,18, 19 B17,18	-----	-----

Note: The Cat. No. 384 operates from + and - 8V. These voltages are created from the + and - 15V rails by regulators IC3 and IC4, mounted at the lower right hand corner of the backplane. J105 pin 3 is -8V and pin 4 is +8V.

APPENDIX A

CHECKING PHASING OF SPEAKERS

Loudspeakers are two-wire devices that can be connected incorrectly as well as correctly. Incorrectly wired loudspeakers in a multiple-speaker installation cause degraded performance. For example, woofers in an array must work together to generate a solid wavefront of sound pressure. If some woofers are moving in one direction at the same time that other woofers are moving in the opposite direction, the result is partial cancellation and hence loss of bass. (The lower the frequencies being handled, the greater is the cancellation.) Wiring can be reversed inside a connector, a transformer can be mislabeled, and the internal wiring polarities of mixers, crossovers, voice coils, and other inaccessible equipment may be unknown.

The Cat. No. 85C pink noise generator can be used to determine correct speaker phasing. Position a microphone as shown on page 5.7 and connect it to the RTA. Switch on pink noise to the center channel in phase (C switch down) and observe the RTA display. Switch on pink noise to the left channel in phase (L switch down). The level in each band displayed on the RTA should rise by 2 to 4 dB. If the level in any band decreases then check phasing of the speaker connections. Repeat this procedure for center and right channel speakers.

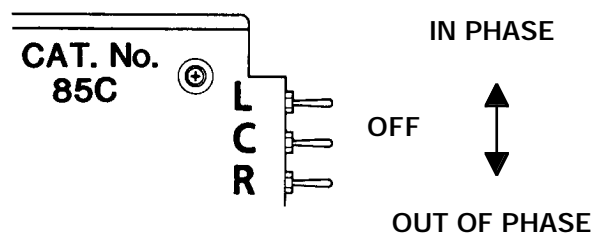

A number of hand-held devices are available to assist the installer to determine if the speakers in a theatre installation are correctly wired. Virtually all such devices consist of two units — a pulse or tone generator which is connected to the speaker being tested — and a polarity detector which is driven either by an integral or external microphone. The detector contains LEDs which indicate the direction of motion of the speaker. It is necessary only to connect the generator to the speaker being tested and turn on the test signal. The detector LEDs automatically indicate the direction of motion. It is sometimes difficult to interpret the indication given on these devices, but they are useful in determining whether several loudspeakers behave identically. (If a special adapter cable is made, the generator can be connected to the CP65 aux input or the L and R output test points on the Cat. No. 240 module so the phase check will include all of the system after the optical preamplifier.)

It is strongly recommended that the phasing of all of the speakers be checked before any of the alignment procedures are started.

Typical phasing checkers are as follows:

SCV Audio Model PC80-439 available from QMI, 15 Strathmore Road, Natick, MA 01760

Cricket Polarity Test Set available from Galaxy Audio, 625 E. Pawnee, Wichita, KS 67211

Check with your dealer for complete information on these and other systems.

APPENDIX B

EFFECT OF CHANGES IN SLIT HEIGHT ON SLIT LOSSES

The slit has a finite height that cannot be reduced without a simultaneous reduction in the light output and, thus, the electrical output of the system. The exciter lamp supply output could be increased in an effort to compensate, but this would shorten the life of the lamp. Equally, the cell preamplifier gain could be increased, but this could cause unwanted hum and noise. The slit acts essentially as a high-frequency filter that has a sharp roll-off to a null at the specific frequency at which the slit height is equal to a recorded wavelength. High-frequency roll-off of the optical cell output is dictated by this slit loss that is, in turn, a function of the wavelength at which these physical factors are equal. The resulting cancellation frequency varies almost exclusively with the height of the slit. The shape of the roll-off curve is essentially independent of the height of the slit; only the cancellation frequency depends on it.

Unfortunately, a conventional treble control cannot compensate for the slit loss characteristic because of its fixed turnover frequency and the gradual slope of the curve. What is needed is a curve that precisely complements the slit loss function by the provision of a boost that can be shifted in frequency to compensate for various slit heights. This is provided by the Dolby optical preamplifiers contained in the Cat. No. 240A.

The figures below show the slit losses at the indicated frequencies and the equalization circuit characteristic for slit heights from 0.00075 to 0.00175 inch (0.018375 mm to 0.042875 mm).

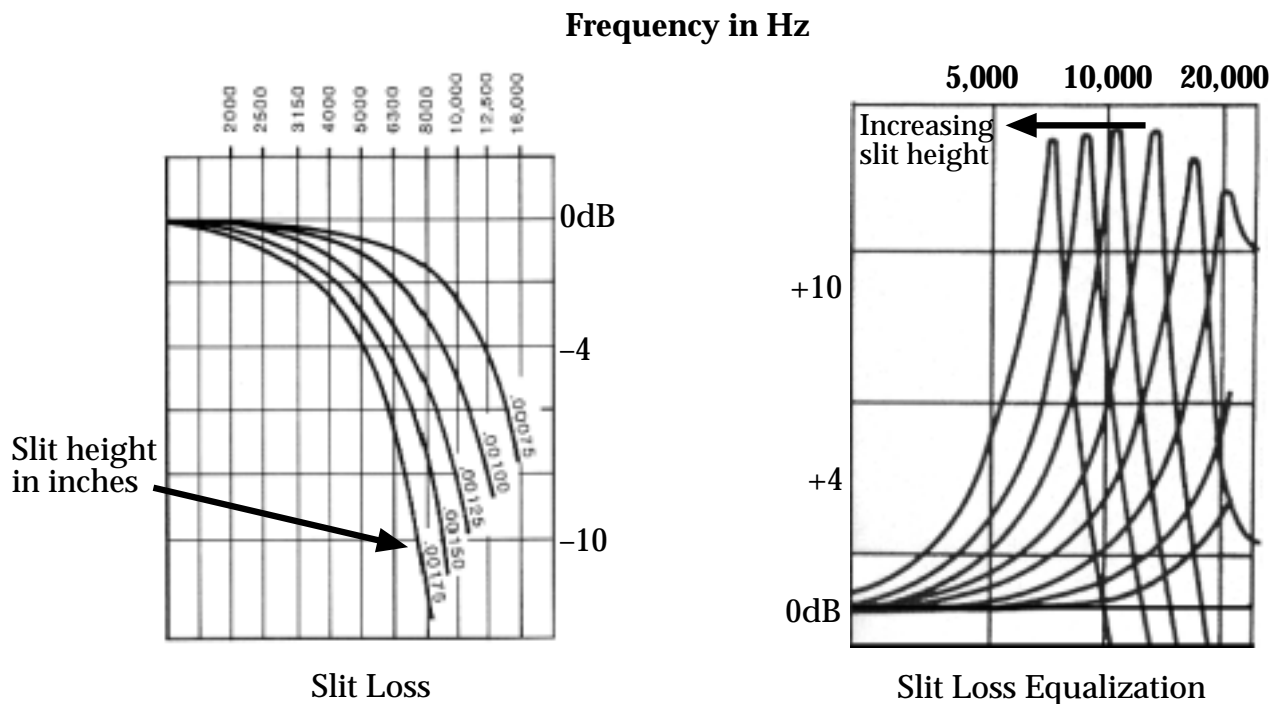

APPENDIX C

CP65M (MONO) INSTRUCTIONS

1. Operation

The CP65 can be configured for mono-only operation. Systems so equipped are shipped with only the center channel Cat. No. 64 house equalization module and without the Cat. No. 150 surround decoder module and Cat. No. 241 or 441 surround equalizer and optical bass extension board. A Cat. No. 327A mono board replaces the Cat. No. 150 module. The Cat. No. 443 control board should have diode D56 in the INC (Inhibit Center) row removed.

When the system is so configured, optical and non-sync sources will be summed and sent to the center channel via the fader or faders and house equalization. When using non-sync inputs the left, right, and center LEDs on the Cat. No. 242 will light although signal will only be present at the center channel output. Magnetic and auxiliary center channel inputs can be selected by choosing the appropriate format using the front panel controls.

Mono films should be played using format 01 Mono. However, with the CP65M, Dolby Stereo films can be screened with the noise reduction and wider frequency response usually only available in Dolby Stereo theatres. Simply select format 04 Dolby Stereo A-type. This turns on the noise reduction circuitry and disables the mono filter. Although the sound will be monophonic, the quality of reproduction will be improved. If your CP65M is fitted with Cat. No. 300 or 350 modules, you can play Dolby Stereo SR prints best by selecting format 05 Dolby Stereo SR.

Follow the level adjustment procedures in the installation and alignment manual. Adjust only the center channel.

2. Cat. No. 327A Circuit Description

The Cat. No. 327A mono board accepts four inputs: optical Lt and Rt from the Cat. No. 222 or Cat. Nos. 350/300 at both 300 and 500 mV levels. All inputs are combined and fed to the output, which appears at the same pin as the center output of a Cat. No. 150.

The Cat. No. 327A may be replaced by a Cat. No. 327 but this will require re-adjustment of levels. Follow the level adjustment procedures in the installation and alignment manual. Adjust only the center channel.

A signal present LED is provided at the output of the Cat. No. 327A. It will come on at about 15 dB below Dolby level, which is the same threshold as the other signal present lights in the system.

C.2

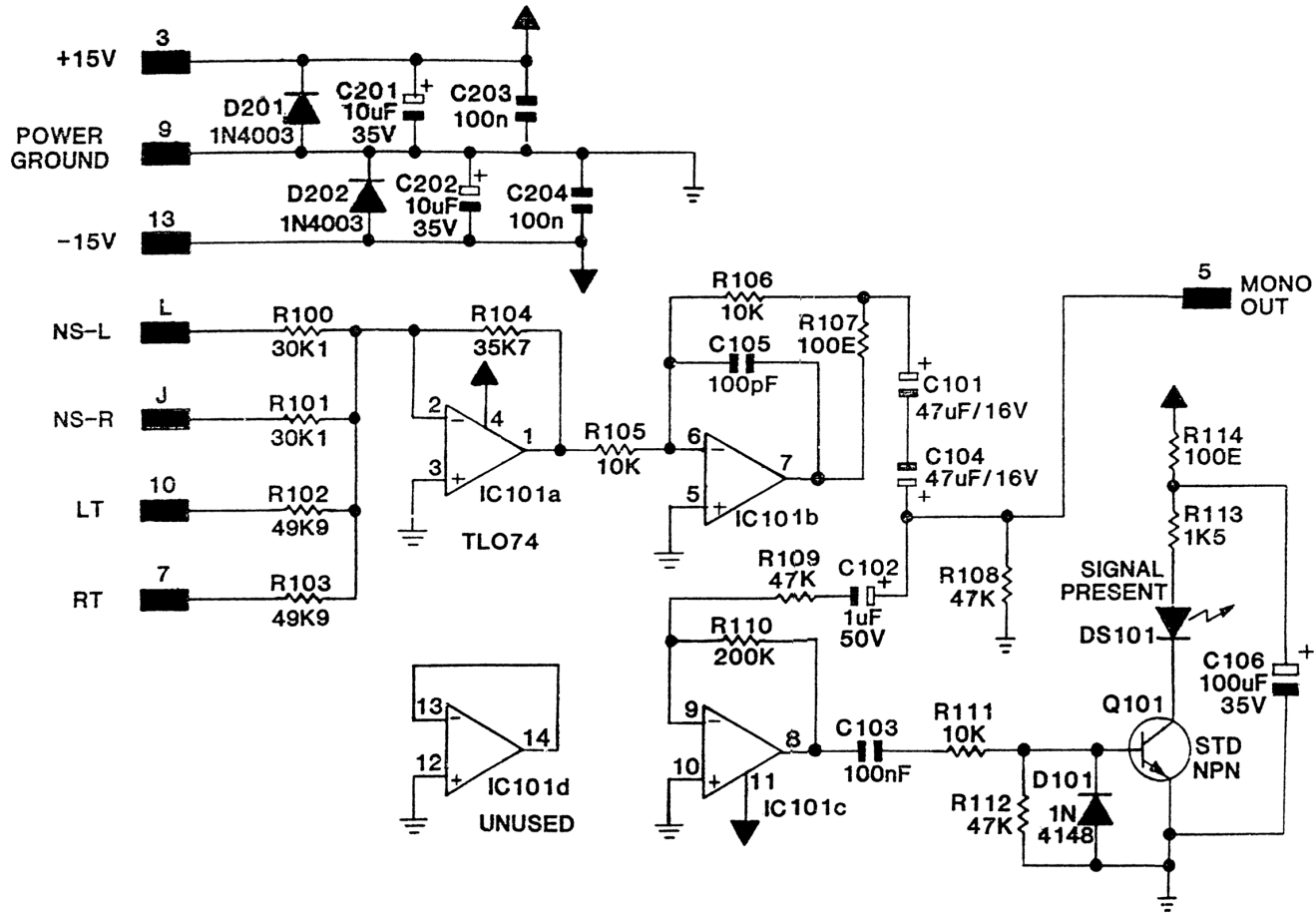

Schematic Cat. No. 327A
A3C2984 rev 2

APPENDIX D BACKPLANE CONNECTIONS LIST

CP65 Backplane Connections

Terminal Block TB1

- 1 Left non-sync i/p
- 2 Right non sync i/p
- 3 ground
- 4 S0 [automation select] fmt 01 Mono
- 5 S1 [automation select] fmt 04 Dolby A-type
- 6 S2 [automation select] fmt 05 Dolby SR [optical]
- 7 S3 [automation select] fmt 60 non-sync via matrix
- 8 S4 [automation select] fmt 10 Dolby Stereo Digital
- 9 S5 [automation select] fmt 42 mag aux with NR
- 10 S6 [automation select] fmt 60 non-sync standard
- 11 S7 [automation select] fmt 22 mag aux without NR
- 12 [automation select] "remote/local" fader
- 13 [automation select] mute
- 14 ground

Terminal Block TB3

- 1 Hearing Impaired o/p
- 2 ground
- 3 Left o/p to power amp
- 4 Center o/p to power amp
- 5 Right o/p to power amp
- 6 ground
- 7 [Left] Surround o/p to power amp
- 8 Right Surround o/p to power amp
- 9 Sub woofer o/p to power amp
- 10 ground
- 11 Left i/p [format 22]
- 12 Centre i/p [format 22]

Terminal Block TB5

- 1 ground
- 2 projector 1 optical i/p left [-]
- 3 projector 1 optical i/p left [+]
- 4 ground
- 5 projector 1 optical i/p right [-]
- 6 projector 1 optical i/p right [+]

Terminal Block TB7

- 1 ground
- 2 projector 2 optical i/p left [-]
- 3 projector 2 optical i/p left [+]
- 4 ground
- 5 projector 2 optical i/p right [-]
- 6 projector 2 optical i/p right [+]

Terminal Block TB2

- 1 [automation select] projector changeover
- 2 ground
- 3 Cat. No. 122 connection "C"
- 4 Cat. No. 122 connection "E"
- 5 Cat. No. 122 connection "B"
- 6 Cat. No. 122 connection "A"
- 7 Cat. No. 122 connection "D"
- 8 chassis
- 9 ground
- 10 ground
- 11 left pre-amp o/p [Lt]
- 12 right pre-amp o/p [Rt]

Terminal Block TB4

- 1 Right i/p [format 22]
- 2 Surround i/p [format 22]
- 3 Le i/p [format 42]
- 4 Re i/p [format 42]
- 5 ground
- 6 Left i/p [format 10]
- 7 Center i/p [format 10]
- 8 Right i/p [format 10]
- 9 Ls i/p [format 10]
- 10 Rs i/p [format 10]
- 11 Sub woofer i/p [format 10]
- 12 ground

Terminal Block TB6

- 1 Left i/p [format 42]
- 2 Center i/p [format 42]
- 3 Right i/p [format 42]
- 4 Surround i/p [format 42]
- 5 ground
- 6 no connection

D connector J18

- 1 S0 [automation select] fmt 01 Mono
- 2 S1 [automation select] fmt 04 Dolby A-type
- 3 S2 [automation select] fmt 05 Dolby SR [optical]
- 4 S3 [automation select] fmt 60 non-sync via matrix
- 5 S4 [automation select] fmt 10 Digital
- 6 S5 [automation select] fmt 42 mag aux with NR
- 7 S6 [automation select] fmt 60 non-sync standard
- 8 S7 [automation select] fmt 22 mag aux without NR
- 9 [automation select] "remote/local" fader
- 10 [automation select] mute
- 11 "-15 volts"
- 12 ground
- 13 "+15 volts"
- 14 ID0 [automation indicator] fmt 01 Mono
- 15 ID1 [automation indicator] fmt 04 Dolby A-type
- 16 ID2 [automation indicator] fmt 05 Dolby Stereo SR [optical]
- 17 ID3 [automation indicator] fmt 60 non-sync via matrix
- 18 ID4 [automation indicator] fmt 10 Dolby Stereo Digital
- 19 ID5 [automation indicator] fmt 42 mag aux with NR
- 20 ID6 [automation indicator] fmt 60 non-sync standard
- 21 ID7 [automation indicator] fmt 22 mag aux without NR
- 22 IDF local [automation indicator] "remote/local" fader
- 23 IDF mute [automation indicator] mute
- 24 connection to Cat. No. 384
- 25 projector changeover status logic o/p