

# FILM-TECH

**THE INFORMATION CONTAINED IN THIS ADOBE ACROBAT PDF FILE IS PROVIDED AT YOUR OWN RISK AND GOOD JUDGMENT.**

**THESE MANUALS ARE DESIGNED TO FACILITATE THE EXCHANGE OF INFORMATION RELATED TO CINEMA PROJECTION AND FILM HANDLING, WITH NO WARRANTIES NOR OBLIGATIONS FROM THE AUTHORS, FOR QUALIFIED FIELD SERVICE ENGINEERS.**

**IF YOU ARE NOT A QUALIFIED TECHNICIAN, PLEASE MAKE NO ADJUSTMENTS TO ANYTHING YOU MAY READ ABOUT IN THESE ADOBE MANUAL DOWNLOADS.**

**[WWW.FILM-TECH.COM](http://WWW.FILM-TECH.COM)**



# Digital Theater Systems

Installation and Operation Manual

DTS-ES Extended Surround Decoder



June 24, 2002

DTS Part #9301E194001.2

**DTS Europe**

Digital Theater Systems (UK) Ltd  
5 Tavistock Estate  
Ruscombe Lane  
Twyford, Berkshire RG10 9NJ, UK  
Phone: +44 (0) 1189.349.199  
Fax: +44 (0) 1189.349.198  
E-mail: [dtsinfo@dtsonline.co.uk](mailto:dtsinfo@dtsonline.co.uk)

**Digital Theater Systems, Inc.**

5171 Clareton Drive  
Agoura Hills, CA 91301  
Phone: 1.800.959.4109 or 1.818.706.3525  
Fax: 1.818.706.1868  
E-mail: [dtsinfo@dtsonline.com](mailto:dtsinfo@dtsonline.com)  
[www.dtsonline.com](http://www.dtsonline.com)

**DTS Japan**

AT Communications KK (Liaison Office)  
2-14-4 Shinonome, Koto-ku  
135-0062 Tokyo, Japan  
Phone: +81 (0) 3.5564.7156  
Fax: +81 (0) 3.3520.1022  
E-mail: [asano@dtstech.co.jp](mailto:asano@dtstech.co.jp)  
[www.dtstech.co.jp](http://www.dtstech.co.jp)

<u>SECTION</u>	<b>TABLE OF CONTENTS</b>	<u>PAGE</u>
I.	DESCRIPTION	
	How the DTS-ES Works .....	1-1
	Figure 1: Signal Routing Block Diagram .....	1-2
	Specifications .....	1-3
	Rack Mounted Installations .....	1-4
	Regulatory Notices .....	1-5
	Warranty .....	1-5
	Returns .....	1-5
	Unpacking .....	1-6
	Equipment Required For Setup .....	1-6
11.	INSTALLATION	
	Mechanical and Electrical .....	2-1
	Front Panel .....	2-2
	Rear Panel .....	2-4
III.	MENUS	
	Operation Menus .....	3-1
	ES-Mode Audio Setup Menus .....	3-2
	Stereo-Mode Audio Setup Menus .....	3-4
	Special Operation Menus .....	3-6
IV.	SETUP	
	Standard Programming Overview .....	4-1
	Menu # 9 “Auto Enable” Programming .....	4-2
	Code Truth Table .....	4-3
	Setup With A DTS-6AD .....	4-4
	Setup With A Non-DTS Cinema Processor .....	4-11
V.	DIAGRAMS	
	Connector Pin-out Tables .....	5-1
	System Wiring Diagrams .....	5-2
	F115, Interface “Opto” Board Schematic Diagram .....	5-10
	F120, DTS-ES Timecode “Y” (adapter for one projector) Cable Diagram .....	5-11
	F117, DTS-ES “ANALOG OUT” Cable Diagram .....	5-12
	F116, DTS-ES “ANALOG IN” Cable Diagram .....	5-13
VI.	TROUBLESHOOTING	
	Inside the DTS-ES .....	6-1
	Troubleshooting Guide .....	6-1
	Replacement Parts List .....	6-3
	DTS Technical Support .....	6-3
VII.	APPENDICIES	
	Appendix A: LINK2 Ground Update .....	A-1
	Appendix B: Using the DTS-ES with a DTS-6AD and two projectors .....	B-1
	E312: Adapter Cable for DTS-6AD With Dual Projectors to DTS-ES .....	B-2
	Appendix C: Using the DTS-ES with a DTS-6/-6D and two projectors .....	C-1
	Appendix D: Connecting DTS-ES to Dolby CP650 .....	D-1

# **NOTES**

*Thank you for choosing DTS !*

## SECTION 1 DESCRIPTION

The DTS-ES is an “Extended Surround” (ES) adapter designed for the latest innovation in encoded surround sound formats. It is fully compatible with all current 5.1 digital formats and systems. The installation is accomplished by inserting the ES unit in the surround signal path between the existing cinema sound processor and the surround power amplifiers. A total of four separate amplifiers are required for powering the four surround channels: Left-Wall Surround, Right-Wall Surround, Left-Back Surround, and Right-Back Surround. If using Auxiliary for a fifth surround channel, that also requires a separate amplifier. **Figure 1** shows the surround signal routing in the ES, Stereo, and Bypass Mode.

Using the latest DSP (Digital Signal Processor) technology, the DTS-ES provides:

- ES decoding of all matrix-encoded stereo-surround sound-tracks
- Digital one-octave equalization of all surround channels
- Level control of all surround channels
- Separate equalization settings for ES and Stereo Modes
- Event closures for special effects (was standard, but after year 2000, available via special order only)

Setup programming is accomplished by front panel buttons and LCD screen which displays the setup menus and unit status. When installed, back panel event closures are provided and can be used to trigger dramatic trailer and feature effects, such as strobe lights and lasers. Volume, EQ, and delay adjustments can be password protected on newer versions of software, which also includes the ability to download settings onto a computer.

### HOW THE DTS-ES WORKS

When in ES Mode, the DTS-ES takes the two “encoded” surround channels and feeds them through the “ES decoder”. The decoder puts the two signals through a matrix that outputs four surround channels: Left-Wall Surround, Right-Wall Surround, Back Surrounds, and Auxiliary Surround. Unless specified otherwise, the “auxiliary surround” channel is not used.

In the **ES Mode**, there is matrix decoding, bass and treble adjustment, master or individual channel level controls, delay adjustments for (side) wall and back surrounds, and one-octave equalization for left surround (LS), right surround (RS), back surround (BS), and Auxiliary channels. In the **Stereo (surround) Mode**, although there is no matrix decoding, it does have bass and treble adjustment, master or individual channel level controls, and one-octave equalization for left surround and right surround channels. There is separate equalization for ES and Stereo Modes, and no equalization for Bypass Mode. In the **Bypass Mode**, the left and right surround channels are routed directly to the output via relays.

The ES Mode can be set for automatic or manual operation. **Automatic** operation of the ES Mode can be accomplished in one of two ways: ① “ES serial numbers” encoded on DTS discs and formatted film, or ② automation sound format closures from the cinema processor. If connected to an existing DTS system, the built-in timecode reader head is used to detect ES serial numbers. If using the DTS-ES in a non-DTS system with a cinema processor that has no automation capabilities, the user must **manually** enable the ES Mode.

If installed, **event closures** can be enabled through special DTS software on the feature or trailer disc(s). In this case, a DTS system must be used. The user may also program event closures (via menu).

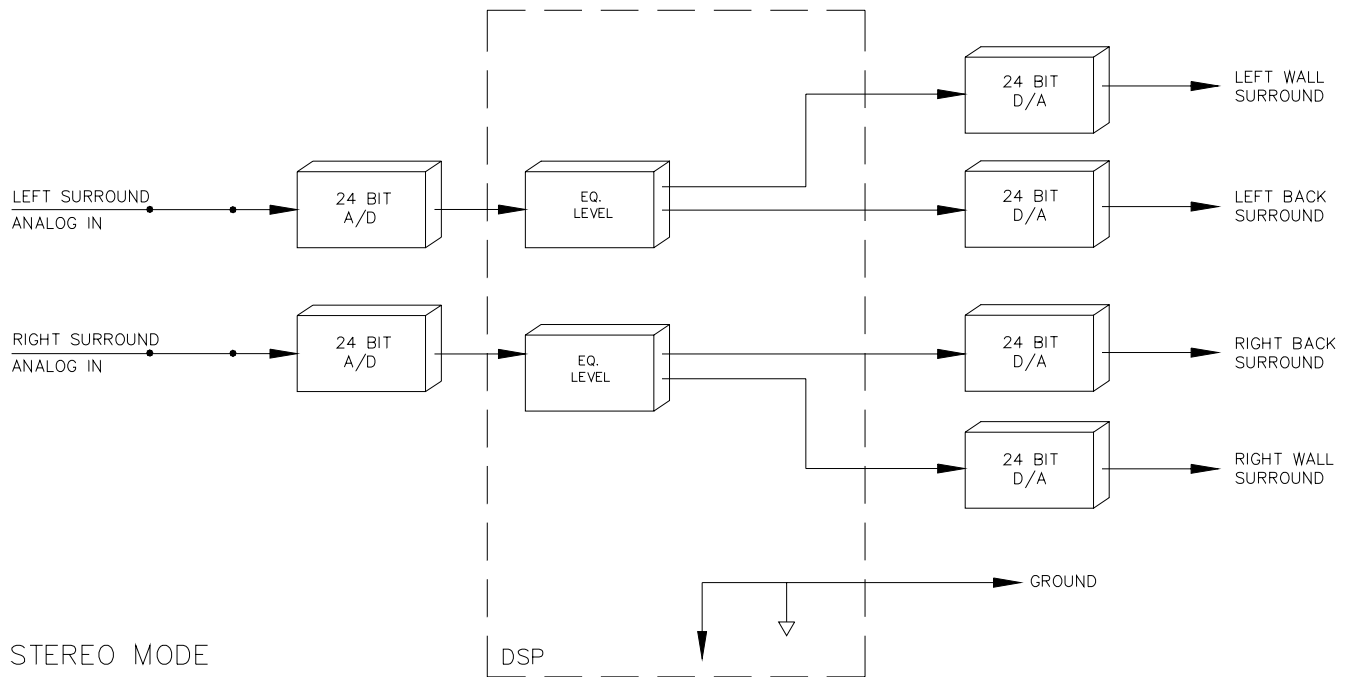
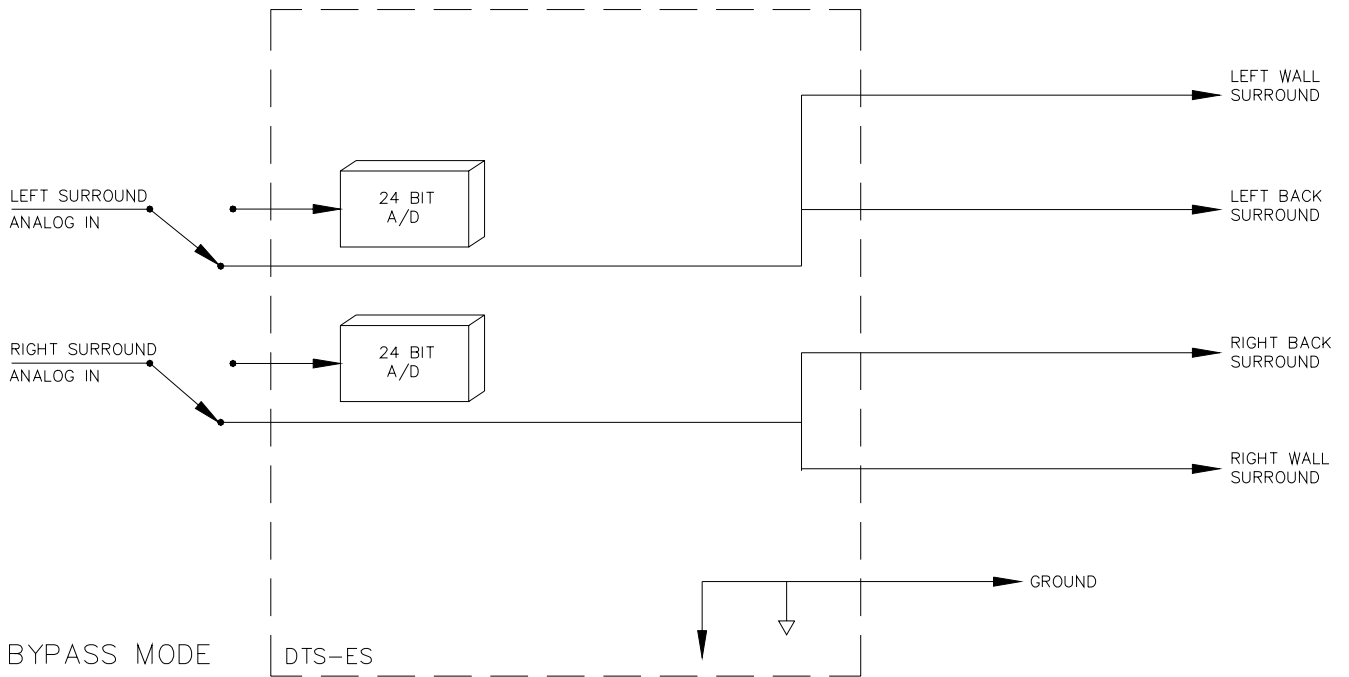

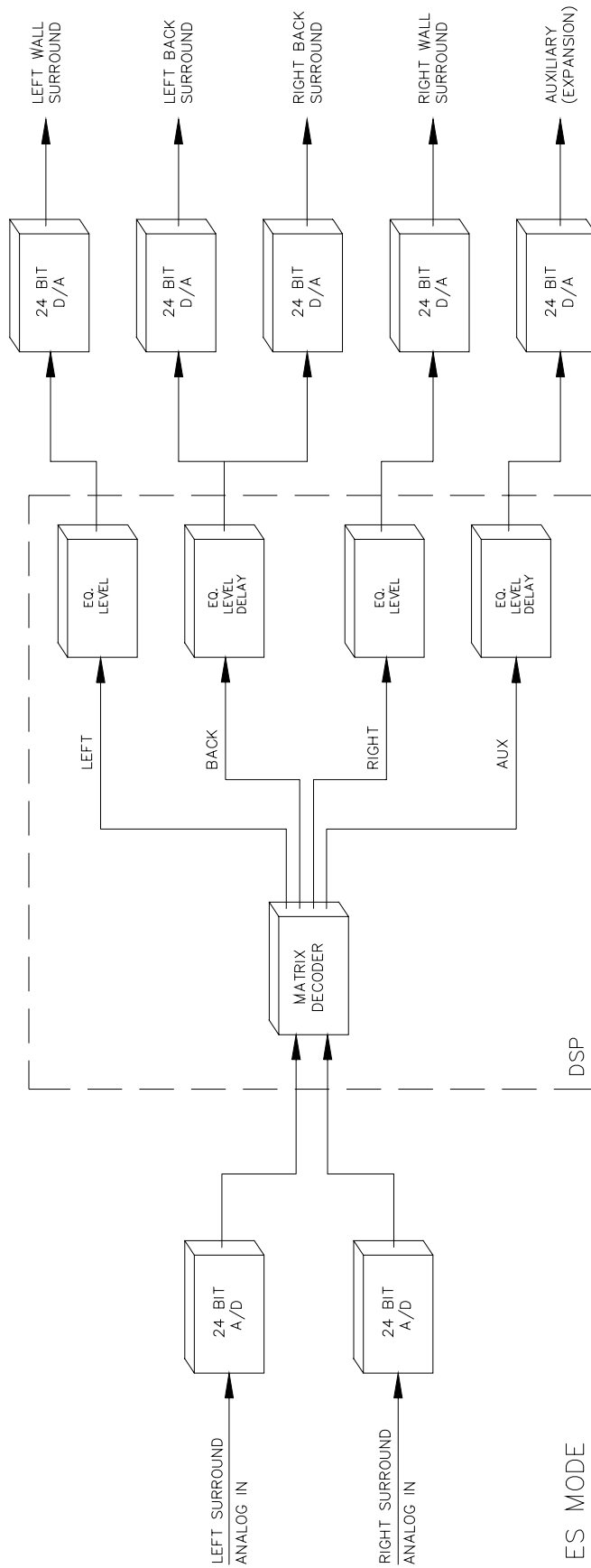

**SPECIFICATIONS**

Frequency Response	20 Hz to 20 kHz all channels
Dynamic Range	>100 dB
Operating AC Voltage Requirements	100 to 240 VAC, at 50 Hz or 60 Hz
Current Draw	115 mA at 120 VAC 60 Hz
Environmental	
Temperature: Storage	0° C to +75° C
Operating	0° C to 50° C
Humidity	10 to 90 % non-condensing
Audio Input Impedance	10K ohm nominal
Audio Input Sensitivity	300 mV at 50 %
Audio Input Level	300mV nominal.
Audio Output Impedance	150 ohm, load greater than 600 ohms.
Maximum output level	+8 dBu
Dimensions	19" rack mount, 1.75" high (one rack unit high), 18" deep (48.26 cm rack mount, 4.445 cm high, 45.72 cm deep)
Weight	10 Lbs. (4.55 kg)
Warranty	1 year parts and labor

**RACK-MOUNTED INSTALLATIONS**

If this product is installed in a closed or multi-unit rack assembly, the following items must be considered:

1. The ambient temperature within the rack may be greater than room ambient temperature. The maximum temperature for the equipment in this environment is 50° C. Consideration should be given to the maximum rated operating temperature.
2. Installation should be such that the amount of air-flow required for safe operation is not compromised, and that a hazardous condition is not achieved due to uneven loading.
3. Check nameplate ratings to assure there is no overloading of supply circuits that could have an effect on over-current protection and supply wiring.
4. Reliable grounding of this equipment should be maintained. Particular attention should be given to supply connections when attaching to power strips, rather than direct connections to the branch circuit.
5. A quality surge / spike suppresser power strip is recommended to protect the DTS-ES circuitry.



## REGULATORY NOTICES

### EMI Notice

This equipment has been tested and found to comply with the limits for a Class A digital device, pursuant to Part 15 of the FCC Rules. These limits are designed to provide reasonable protection against harmful interference when the equipment is operated in a commercial environment. This equipment generates, uses, and can radiate radio frequency energy and, if not installed and used in accordance with the instruction manual, may cause harmful interference to radio communications. Operation of this equipment in a residential area is likely to cause harmful interference in which case the user will be required to correct the interference at his own expense.

### Canadian Department of Communications compliance statement:

This equipment does not exceed Class A limits per radio noise emissions for digital apparatus set out in the Radio Interference Regulation of the Canadian Department of Communications. Operation in a residential area may cause unacceptable interference to radio and TV reception requiring the owner or operator to take whatever steps are necessary to correct the interference.

### *Avis de conformité aux normes du ministère des Communications du Canada:*

Cet équipement ne dépasse pas les limites de Classe A D'émission de bruits radioélectriques pour les appareils numériques telles que prescrites par le Règlement sur le brouillage radioélectrique établi par le ministère des Communications du Canada. L'exploitation faite en milieu résidentiel peut entraîner le brouillage des réceptions radio et télévision, ce qui obligerait le propriétaire ou l'opérateur à prendre les dispositions nécessaires pour en éliminer les causes.

### CE Notice

This is a Class A product. In a domestic environment this product may cause radio interference in which case the user may be required to take adequate measures.

Passes requirements set by **UL** and **CUL**

## WARRANTY

Equipment manufactured by Digital Theater Systems, Inc. is warranted against defects in materials and workmanship for one year from date of purchase. There are no other express or implied warranties.

Digital Theater Systems, Inc. obligation is restricted to repair and replacement of defective parts. Under no circumstances will Digital Theater Systems, Inc. be liable for any other damage, either direct or consequential.

All requests for repairs or information should include the unit serial number to ensure rapid service.

## RETURNS

For repair, exchange, or to obtain replacement parts, please call local dealer or DTS at (818) 706-3525 or USA toll free (800) 959-4109 for a Return Authorization number **before** sending any item back to the factory. At the time of the call, DTS requires the serial number of any DTS product returning **before** warranty replacement units will be sent. All return packaging should be clearly marked with the Return Authorization number on the **outside** of the package. DTS Customer Service FAX: (818) 879-2746.

### **Please send all returns to:**

Digital Theater Systems  
5171 Clareton Drive  
Agoura Hills, California 91301 USA

## UNPACKING

The packaging is designed to handle normal shipping and handling. Upon receipt of shipment, check for signs of damage before opening and report all damage to the carrier. All shipments made from DTS are the customer's responsibility once the package leaves our premises.

Before installation is begun, it is suggested that a complete inventory be taken to minimize problems or questions during installation. Additionally, save all packing material until installation is complete in the unlikely event that a component requires return to the factory. Use the packing slip that came with the unit to verify received inventory.

The following is a sample packing list:

- DTS-ES unit and power cord
- F120, Timecode "Y" cable adapter
- F116, Analog-In Cable
- F117, Analog-Out Cable
- F115, Interface ("opto") Board
- Installation Hardware (screw kit)
- DTS-ES Manual
- DTS-ES Setup Disc

If any of the items on the packing list cannot be found, contact DTS with the part number and description of the missing item(s). **Refer to "RETURNS,"** (previous page) **when sending any product back to DTS.**

## EQUIPMENT REQUIRED FOR SETUP

- DTS-ES Setup Disc
- Multimeter
- Sound pressure level meter (set for slow response and C-weighting)
- RTA (real time analyzer) and calibrated microphones with a multiplexer, or a single calibrated microphone.

## SECTION 2                      INSTALLATION

### **Mechanical**

The DTS-ES fits into a standard 19-inch rack, and is one rack unit high. It requires about 16-inches depth to allow for unit and associated cabling. When mounting, make sure that the DTS-ES case is (earth) grounded to the sound rack, which should be connected to AC ground.

### **Electrical, Mains**

Mains AC electrical power is connected to the DTS-ES unit via the IEC connector on the unit's rear panel (very left when looking from the back). The input power rating is 100 volts AC to 240 volts AC, 50 or 60 Hertz. A power cord is included, but verify that it complies with local and national electrical codes. The current draw of the DTS-ES is 115mA at 120 volts AC 60 Hz.

### **Electrical, Wiring**

The installer must connect surround signal wires to the DTS-ES mating connectors (on the rear panel). Cable and wire strain relief should be supplied for all used connectors. All cables must be shielded. Verify that the DTS-ES chassis and sound rack chassis are earth grounded. Route data and audio lines away from RF or other interference fields, such as projector motors or power supplies/cables.

**IMPORTANT NOTE: Follow all local codes and regulations covering electrical wiring. CONNECT ALL INPUT AND OUTPUT CABLES BEFORE CONNECTING MAINS POWER.**

For **hum problems** check for ground loops, especially at the power amplifiers. Make sure the projector motor wiring is correct and the projector grounds are in place. Check the booth monitor wiring and the room lighting dimmer controls.

### **Electrical, signals**

To assist in a quick setup, accessory cables are provided: Analog input (F116), Analog Output (F117), and a "Y" cable (F120, timecode interface). Also, an ES interface "opto" board (F115) is provided to support the logic (format) control keys from the cinema processor.

- **ANALOG IN Connection**

Disconnect the surround output wiring from the existing cinema processor. Leave these cables connected to the power amplifiers & booth monitor. Mark each cable to identify its channel. These connections will go to the DTS-ES rear panel connector ANALOG OUT. The pin-out for this connector is in Section 5.

- **ANALOG OUT Connection**

New cables will be used to connect signals from the existing cinema processor to the DTS-ES rear panel connector ANALOG IN. The pin-out for this connector is in Section 5.

- **COM, TIMECODE IN, EVENT OUT Connections**

Use F120 for TIMECODE IN. If using COM and EVENT OUT, wire them per the diagrams in Section 5.

- **REMOTE IN Connector**

The F115 interface "opto" board plugs to this connector. The F115 is wired to the cinema processor's automation connections. See Section 5 for details.

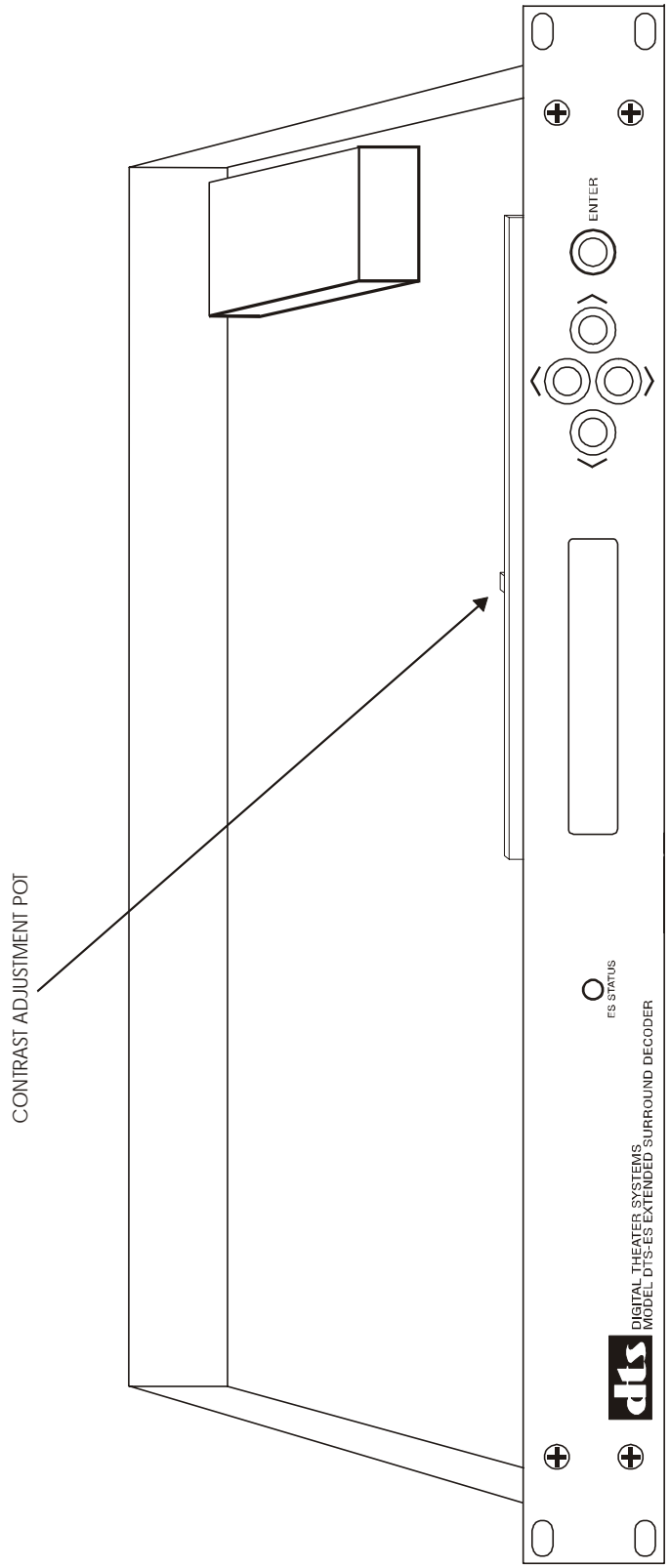

Figure 2: DTS-ES Front Panel

## FRONT PANEL

### ES Status Lamp

This lamp has three states:

Off = Bypass Mode  
RED = Stereo Mode  
GREEN = ES Mode

### LCD (display) and the four directional buttons

The two-line LCD works in conjunction with the “soft” buttons to the right of the display. The ▲ ▼ buttons allow a choice of menus and the ◀ ▶ buttons allow a choice of menu items. In some menus, the ▲ ▼ buttons allow increasing/decreasing a numerical value. In this case, one of the menu choices will be an “EXIT” command.

### ENTER button

The “ENTER” button is used to save audio settings when in the programming menu. The audio setup values are saved in memory and will be active upon power up. Re-entering the audio programming menu enables the user to make changes to audio settings. The audio programming menu may be password protected.

### Contrast Adjustment

This potentiometer is located behind the front panel. It adjusts the brightness of the display screen.

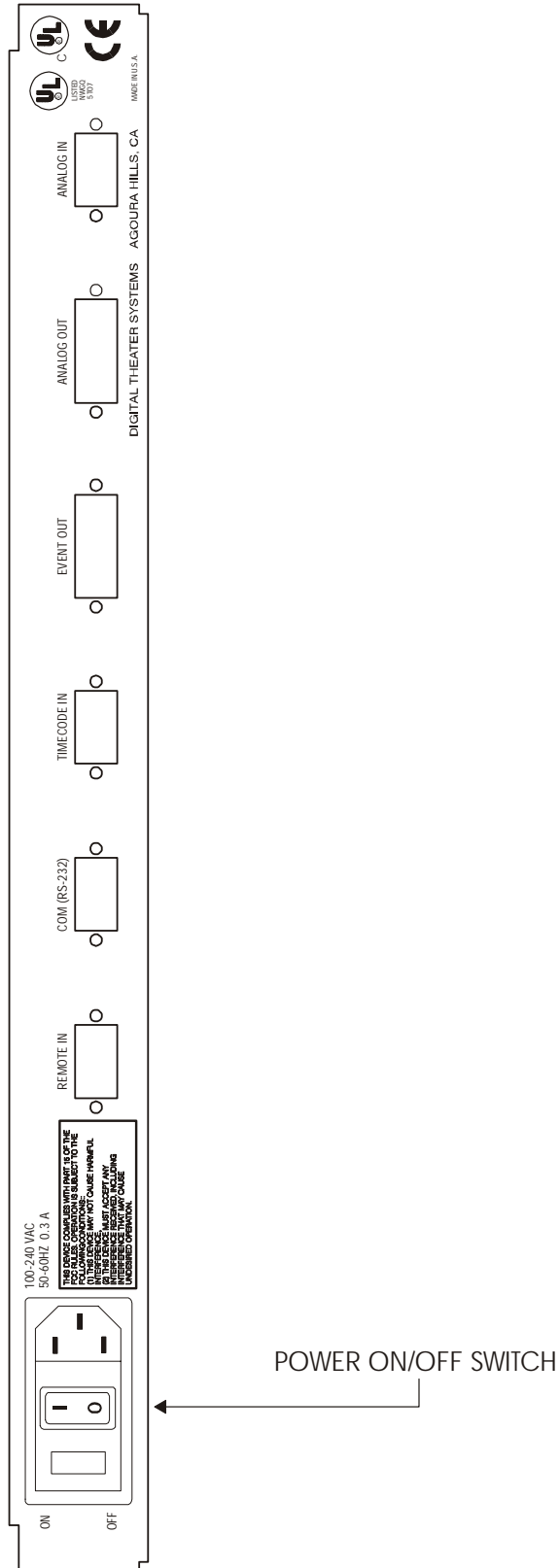

Figure 3: DTS-ES Rear Panel

**REAR PANEL**

Universal AC power input	Unit accepts between 100 to 240 volts AC, at 50 to 60 Hertz.
Power switch	Switches AC input power on/off
DB-9F "REMOTE IN" Connector	Enables the use of a remote control device (automation)
DB-9M "COM (RS232)" Connector	Will enable the ability to download programmed audio settings. Requires ES upload/download software (future).
DB-9M "TIMECODE IN" Connector	Receives timecode signal from DTS timecode reader
DB-15F "EVENT OUT" Connector	Feeds event closures to external device (strobes, lasers, etc.) <b>**This connector will not be available on standard units manufactured after year 2000**</b>
DB-15M "ANALOG OUT" Connector	Feeds surround signals back to the amplifiers/monitor.
DB-9F "ANALOG IN" Connector	Receives surround signals from existing cinema processor

# **NOTES**

*Thank you for choosing DTS !*



## SECTION 3 MENUS

There are two types of Menus in the DTS-ES: **Operation** and **Audio Setup Menus** (ES and Stereo). While programming, choices are indicated by capital (upper case) letters. Choices not enabled are indicated by lower case letters. Choices can be stored and saved, and **downloaded** onto a computer. The Audio Setup Menu is **password** protected on units with software V1.1 and above.

To step down through the menus, press the  $\nabla$  button. To quickly move through all the menus, press either the  $\blacktriangle$   $\nabla$  buttons (depending on the direction needed) once, let go, and then hold down the same button to quickly scroll through the menus. The order of screens and menus are given below:

### START SCREEN

```

DTS Inc.
Extended Surround System
    
```

### OPERATION MENUS

#### Menu # 1

```

Analog Output Mode:
  NORMAL    bypass
    
```

Set to "NORMAL" for setup and standard operation. When BYPASS is selected, the surround inputs are directly connected to the outputs via relays.

#### Menu # 2

```

ES Control Mode:
  MANUAL    auto
    
```

Should not be activated AUTO until Menus # 3 and # 9 are set. Setup done in MANUAL.

#### Menu # 3

```

Current Surround Mode:
  ES        stereo
    
```

Indicates the surround mode. In ES Mode, the status lamp is green. In STEREO Mode, the status lamp is red. BYPASS = status lamp extinguishes.

#### Menu # 4

```

ENTER to save I/O, event
& format configuration.
    
```

This appears so that the programmed choices can be stored and saved. This enables the same configuration to appear after cycling power on the unit. Press ENTER to save choices in Menus # 1 through # 3 ("I/O configuration")

**\*\* NOTE \*\***

**DTS-ES units with software below V1.1, will not have Menu # 5. Instead, the audio setup menus will appear.**

#### Menu # 5

```

ENTER password to access
audio menus:  EXIT    000
    
```

This enables the user to password-protect the choices made in the Audio Setup menus (ES or Stereo). The **password is "123"** and cannot be changed.

- To enter the password, press  $\blacktriangleright$  button until the first zero is underlined: exit 000
- Press the  $\blacktriangle$  button until a "1" appears. Press  $\blacktriangleright$  button. The second zero should be underlined: exit 010
- Press the  $\blacktriangle$  button twice, until a "2" appears. Press  $\blacktriangleright$  button. The third zero should be underlined: exit 010
- Press the  $\blacktriangle$  button 3 times, until a "3" appears. The screen should display: exit 0123
- Now, press ENTER button. The **Audio Setup** screens can now be accessed. The first audio setup screen should appear, as seen on page 3-2 (for ES Mode ) or page 3-4 (for Stereo Mode).

**If EXIT is highlighted and the  $\nabla$  button is pressed, Menu # 6 will appear.**

### ES-MODE AUDIO SETUP MENUS

In this section, the  $\blacktriangleleft$   $\blacktriangleright$  buttons change the dB value (and volume bar, if applicable). The  $\blacktriangle$   $\nabla$



### ES Audio Setup # 10

```
Back Surround Ch tone:
EXIT  ba:+00dB  tr:+00dB
```

This is a coarse EQ adjustment for the back surround channel. The “ba” is BASS and “tr” is TREBLE. The steps are 1dB and the range is from -10dB to +10dB.

### ES Audio Setup # 11

```
Back Surround Ch tone:
EXIT  ba:+00dB  tr:+00dB
```

This is a fine-tune EQ adjustment for the back surround channel. See ES Audio Setup # 7 for details.

### ES Audio Setup # 12

```
ES Channel Delay Setup:
EXIT  bs:00ms   ax:00ms
```

This allows the user to set delay for the back surrounds (“bs”) and auxiliary surround (“ax”) channels. The delay range is 0 to 50 **milliseconds** in 1ms steps. To adjust delay, see example below:

**Example: Back surround needs 10ms delay.**

- Press **➤** button until back surround is underlined.

```
ES Channel Delay Setup:
exit  B-SURR:00ms   ax:00ms
```

- Press the **▲ ▼** buttons until 10ms is achieved.

```
ES Channel Delay Setup:
exit  B-SURR:10ms   ax:00ms
```

- Press **◀** button to “EXIT”. The setting should be seen on the ES Channel Delay screen (below)

```
ES Channel Delay Setup:
EXIT  bs:10ms   ax:00ms
```

**After delay is set and the ▼ button is pressed, the save screens appear in the order shown below.**

### Save ES Audio Settings

```
ENTER to save EQ, Tone &
Vol., Delay for ES mode.
```

After setting EQ, Tone, Volume, and Delay for the ES mode, press the ENTER button to save the values. Once ENTER is pressed, the screen below will appear.

```
Saving parameters now ....
Please wait ....
```

Then, if successful, the screen below will appear.

```
Current setting is saved
As default for ES Mode.
```

All ES Mode Audio settings are now saved and will be active when unit is in the ES mode. They will reappear after cycling power.

**After saving audio setups, the screen below appears.**

### Exit ES Audio Setup

```
Exit audio setup menus?
Yes      no
```

This screen allows the user to confirm audio setups are completed and move on to special operation menus.

- If changes are needed, press the **➤** button until “No” is underlined and then press ENTER. The screen will return to ES Audio Setup # 1.
- If **ES Audio** setup is complete, press ENTER (with “Yes” underlined). The screen will jump to Menu # 6.
- If **Stereo Audio** setup is needed, press ENTER (with “Yes” underlined) and go back to Menu # 3. Change mode to STEREO. Once set to Stereo Mode, proceed through Menus #3 to #5, and Stereo Setup # 1.

### STEREO -MODE AUDIO SETUP MENUS

In this section, the **◀ ▶** buttons change the dB value (and volume bar, if applicable). The **▲ ▼** buttons move the user through other Stereo Setup menus. Set **Menu #2** to “MANUAL” and **Menu #3** must be set for “Stereo” to access these seven

Stereo Setup Menus and single Stereo “save” sequence.

**Stereo Setup # 1**

```
Master Volume:          -00dB
nnnnnnnnnnnnnnnnnnnnnnnn
```

This is used to attenuate all surround outputs in 2dB steps from 0dB to -48dB.

**Stereo Setup # 2**

```
Left Surr. Vol:        -00dB
nnnnnnnnnnnnnnnnnnnnnnnn
```

This is used to attenuate the left surround output in 1dB steps from 0dB to -24dB.

**Stereo Setup # 3**

```
Right Surr. Vol:       -00dB
nnnnnnnnnnnnnnnnnnnnnnnn
```

This is used to attenuate the right surround output in 1dB steps from 0dB to -24dB.

**Stereo Setup # 4**

```
Left Surround Ch tone:
EXIT ba:+00dB  tr:+00dB
```

This is a coarse EQ adjustment for the left surround channel. The “ba” is BASS and “tr” is TREBLE. The steps are 1dB and the range is from -10dB to +10dB.

**Stereo Setup # 5**

```
Left Surround Ch EQ:
EXIT +0+0+0+0+0+0+0+0+0
```

This is a fine-tune EQ adjustment for the left surround channel. The bottom row indicates the dB value assigned to a particular frequency. The position in the string indicates the frequency..

The frequencies are, in order from left to right: 63, 125, 250, 500, 1k, 2k, 4k, 8k, 16k **Hertz**. The **decibel** range is -6 to +6dB, in 0.5dB steps. To make an adjustment, see example below:

**Example: 250Hz needs attenuation of 2dB**

- Press the ➤ button until the third “0” is underlined. Notice the top right corner while pressing the button, the frequency changes allowing the user to locate the frequency of choice.

```
LS Ch EQ:      250Hz ->  +0.0dB
exit  +0+0+0+0+0+0+0+0+0
```

- Once the screen above appears, the user presses the ▲ ▼ buttons to make dB adjustments, from -10dB to +10dB. To achieve -2dB for 250Hz, press the ▼ button until -2.0dB is seen., as shown below:

```
LS Ch EQ:      250Hz ->  -2.0dB
exit  +0+0-2+0+0+0+0+0+0
```

- Once finished, press the ◀ button until EXIT is underlined. Press ▼ button. Once exited, the screen for left surround EQ will look:

```
Left Surround Ch EQ:
EXIT +0+0-2+0+0+0+0+0+0
```

The left surround channel now shows 2dB of attenuation at 250Hz.

**Stereo Setup # 6**

```
Right Surround Ch tone:
EXIT ba:+00dB  tr:+00dB
```

This is a coarse EQ adjustment for the right surround channel. The “ba” is BASS and “tr” is TREBLE. The steps are 1dB and the range is from -10dB to +10dB.

**Stereo Setup # 7**

```
Right Surround Ch EQ:
EXIT +0+0+0+0+0+0+0+0+0
```

This is a fine-tune EQ adjustment for the right surround channel. See Stereo Setup # 5 for details.

**After EQ is finished and the  $\nabla$  button is pressed, the “save” screens appear in the order shown below.**

### Save Stereo Settings

```
ENTER to save EQ, Tone &
Volume for Stereo mode.
```

After setting EQ, Tone, and Volume for the Stereo mode, press the ENTER button to save the values. Once ENTER is pressed, the screen below will appear.

```
Saving parameters now ....
Please wait ....
```

Then, if successful, the screen below will appear.

```
Current setting is saved
as Stereo mode default.
```

All Stereo settings are now saved and will be active when unit is in the Stereo Mode. They will reappear after cycling power.

**After saving audio setups, the screen below appears.**

### Exit Stereo Setup

```
Exit audio setup menus?
Yes no
```

This screen allows the user to confirm audio setups are completed and move on to special operation menus.

- If changes are needed, press the  $\triangleright$  button until “no” is underlined and then press ENTER. The screen will return to Stereo Setup # 1.
- If **Stereo Audio** setup is complete, press ENTER (with “yes” underlined). The screen will jump to Menu # 6.
- If **ES Audio** setup is needed, press ENTER (with “Yes” underlined) and go back to Menu # 3. Change mode to ES. Once set to ES Mode, proceed through Menus #3 to #5, and ES Audio Setup # 1.

**SPECIAL OPERATION MENUS**

**\*\* After year 2000, EVENTS feature available via special order only \*\***

**Menus # 6 and # 7 program EVENTS only.**

**Menu # 6 \*\***

Event-Out Operation Mode		
<u>OFF</u>	stored	auto

This controls the outputs on the rear panel EVENT OUT connector. The outputs are optically isolated solid state relay closures. The solid state relay is the dual FET type that handles AC and DC signals. Use the < > buttons to choose mode:

- Off = Events not used
- Stored = Menu # 7 settings run events
- Auto = Special DTS timecode run events

**Menu # 7 \*\***

Events Setup:	8	7	6	5	4	3	2	1
<u>EXIT</u> 0>00:00000>	<input type="checkbox"/>	<input checked="" type="checkbox"/>	<input checked="" type="checkbox"/>	<input type="checkbox"/>	<input checked="" type="checkbox"/>	<input type="checkbox"/>	<input checked="" type="checkbox"/>	<input checked="" type="checkbox"/>

The DTS-ES has a built-in timecode reader. This menu allows the user to set event commands by programming in the event number, DTS timecode location of the event, and open/close state (actual event) for up to 8 different (relay) event outputs.

- The top row has numbers that refer to the relays, starting with Relay 8 and ending with Relay 1.
- The second row has the EXIT command, plus event ID and relay state indication. Press the < > buttons to make selection.
- **ID:** The first, single digit represents the program number. The user can set up to ten (0 to 9) different event programs. The next two digits indicate the reel number, ranging from 1 to 15. The last 5 digits indicate when an event will occur. The DTS timecode is used identify the occurrence. This is the location in DTS timecode, seen in Menu # 10.
- **Relay:** A dark square (below each relay number) represents a relay closure, and an open square represents an open circuit (for that relay). Use the ▲ ▼ buttons to select relay state.
- **EXIT** to save settings and move to the next menu.

**Menu # 8 (Remote Fader)**

Master-Fader-Input Mode:	
<u>DISABLED</u>	enabled

This correlates with the REMOTE IN connector on the rear panel. The remote control input goes to an 8-bit A-to-D converter. The resulting digital number represents a fader position.

**REMOTE FADER feature is not implemented.**

**Menu # 9 (Auto Enable)**

	TC	code A	code B
<u>EXIT</u>	No	00	00

This menu correlates with the REMOTE IN connector on the rear panel. This menu allows the ES Mode to automatically activate by one of two methods:

- ① A special 5-digit DTS timecode (“TC”) when “Yes” is selected. The function is ignored by selecting “No”. –OR–
- ② By means of an automation contact from the cinema processor. See “**Format Code Choices**”, page 4-3 for details.
- The ES Control Mode must be programmed to AUTO (Menu # 2) and Surround Mode to ES (Menu # 3).

**EXIT** to save settings and move to next menu.

**Menu # 10 (Timecode Reader)**

P1:	00000-->00:00000
P2:	00000-->00:00000

This screen enables the user to see the DTS timecode as being read by the DTS reader while film is playing. The first five digits represent a serial number, the next two a reel number, and the last five the frame number. The numbers after the arrow are used to identify a location in DTS timecode, used in Menu # 7. P1 = Projector 1. P2 = Projector 2.

**End Screen**

Product Revision	1.1
Design Date:	Nov. 1999

This screen shows the software version number and the design date of the software.

## SECTION 4                    SETUP

### 4.1.    STANDARD PROGRAMMING OVERVIEW

#### Menu # 1

Analog Output Mode:	
<u>N</u> ORMAL	bypass

- Set to NORMAL during setup and all standard operation.
- BYPASS is used for setting surround SPL on the cinema processor or in case of DTS-ES failure. The front panel ES STATUS LED is extinguished while in BYPASS Mode. When the power is off, the DTS-ES automatically switches into the BYPASS Mode.
- The ES STATUS LED will be green for ES Mode, red for STEREO Mode, and extinguished for BYPASS Mode and power off.

#### Menu # 2

ES Control Mode:	
<u>M</u> ANUAL	auto

- Set “ES Control Mode” to MANUAL for setup of the DTS-ES and when ES Mode is not needed.
- With unit set to “MANUAL”, ES or STEREO decoding is selected by changing Menu #3 “Current Surround Mode” between “ES” and “Stereo”.

#### Menu # 3

Current Surround Mode:	
<u>E</u> S	stereo

- With the unit set to “AUTO”, ES or STEREO decoding is determined by the input to the TIMECODE IN (via F120 cable) and REMOTE IN (via F115 board) connectors. AUTO can not be selected until Menu #9 “Auto Enable” has been programmed.

#### Menu # 9 (Auto Enable)

	TC	code A	code B
<u>E</u> XIT	Yes	00	00

- Once unit is set to “AUTO”, ES decoding is activated only when the criteria of the “Auto Enable” menu has been met.
  - ☒ Menu #9, “Auto Enable” has two main choices:
    - ① To monitor *timecode* (TC) by selecting “Yes” or “No”, and
    - ② To monitor the three control lines of the REMOTE IN (P6) connector by selecting a *format code*. See “Format Codes A & B” (page 4-3) for details.
  - ☒ The ES Mode will automatically activate only when the conditions of TC, Code A, and Code B are met.

### MENU # 9 “AUTO ENABLE” PROGRAMMING

- **Timecode (TC)** F120 “Y” cable must be used. *DTS-ES auto-enabled only by valid ES (5-digit) timecode.*  
**To ensure proper performance, the DTS-ES unit must have software V1.1 (or greater).**
  - ☒ If “Yes” is selected, the DTS-ES will use “ES” TC serial numbers to determine a valid state.
  - ☒ If “No” is selected, the DTS-ES will ignore the “ES” TC serial numbers.
  
- **Format Codes A & B.** *DTS-ES auto-enabled only by desired format closures on cinema processor.*  
 Selecting a “Format Code” is used in conjunction with REMOTE IN (P6) connector. Control inputs from the cinema processor (CP) are sent to the DTS-ES through P6. There are a total of three control inputs that determine a valid “Auto Enable” state. Format Code numbers range from “0” to “10” on Code A and “0” to “8” on Code B. Two separate “Format Codes” (A & B) allow for two different sound format controls from the CP. This is used if both require DTS-ES decoding.
  
- **ES automatic decoding** is activated only if Menu #2 is set to AUTO and Menu #9 conditions are met: The goal is to have the DTS-ES automatically start “ES” decoding whenever the CP switches to “digital”. When properly connected and the CP switches to “digital”, that LED line will be driven, activating the opto-coupler on the F115 board, and in turn enabling ES decoding in the DTS-ES unit.
  - ☒ When TC is set to “Yes”, the DTS-ES only uses special DTS timecode to automatically enable ES decoding. The DTS-ES must be in AUTO Mode. When in AUTO, P6 (remote control) is ignored.
  - ☒ When TC is set to “No”, the DTS-ES only uses the conditions set in the “Format Code” to enable ES decoding while in the AUTO Mode. The “Format Code” choices are given below:
  - ☒ If “Format Code A” is set to “0”, then P6 (remote control) will not enable ES decoding until conditions are properly set in “Format Code”. However, if TC is set to “Yes”, then P6 is ignored and decoding will be enabled by special DTS timecode.
  - ☒ The **DTS-6AD** may use two 6-track sound sources: DTS digital and an alternate (Dolby Digital™, 6-track mag., etc.). On the DTS-6AD, the STATUS/CONTROL A & B connectors, pin 19 is used for DTS playback and pin 18 (EXTERNAL) is used for the alternate.
    - See #18 on page 4-9 for Code A and Code B settings. See wiring diagrams in Section 5.
  - ☒ When using with a **Dolby CP45, CP55, CP65** or an **UltraStereo** processor:
    - See #16 on page 4-15 for Code A and Code B settings.
    - On the DTS F115 Interface {“opto” board) connect OC1 “J1 terminals 1 & 2” to the digital format LED output on the CP. See wiring diagrams in Section 5.
  - ☒ **Dolby Model CP500** may use two digital sound sources: DTS and Dolby Digital™.
    - Use Code A for DTS, typically Soft Key 5 (SK5 on the CP500).
    - Use Code B for Dolby Digital, typically Soft Key 8 (SK8 on the CP500).
    - See #16 on page 4-15 for Code A and Code B settings. See wiring diagrams in Section 5

**NOTE:** Early CP500 do not have the Format Status Bit outputs connected internally. The DTS-ES monitors these outputs to determine what sound format the CP500 is in. Older CP500s require an updated “Dolby Model Cat. No. 684 System Controller Card”, obtained from an equipment dealer.

**NOTE:** Early CP500 software versions may not provide the proper format status outputs. If the “Format Code” for the soft key being monitored does not work, it may require a software upgrade or another code programmed in on the DTS-ES.

### Format Code Choices

- Code 0** No remote operation. If A and B are both set to “0”, the DTS-ES ignores any input to the three control lines of the REMOTE IN connector (P6).



**Codes 1 - 8** Sustained contact using Code Truth Table.

**NOTE:** Format Codes 1 → 8 correspond to SK1 → SK8 on the CP500.

**Code 9** Pulse Mode: Pulse to OC 3 (CTRL 1) activates ES Mode

Pulse to OC 2 (CTRL 2) activates Normal Mode

**NOTE:** Pulse must be a minimum of 100 milliseconds

**Code 10** A sustained contact to any of the three inputs activates the ES Mode. Can be used with a Sony DFP-3000 that has 3 digital sound formats that might require DTS-ES decoding.

### Code Truth Table

F115 “opto” board			DTS-ES J6 connector (from CP)			
OC 1	OC 2	OC 3		CTRL 3	CTRL 2	CTRL 1
				Pin 5	Pin 4	Pin 3
			FORMAT CODE			
			<b>0</b>	X	X	X
0	0	0	<b>1</b>	1	1	1
0	0	1	<b>2</b>	1	1	0
0	1	0	<b>3</b>	1	0	1
0	1	1	<b>4</b>	1	0	0
1	0	0	<b>5</b>	0	1	1
1	0	1	<b>6</b>	0	1	0
1	1	0	<b>7</b>	0	0	1
1	1	1	<b>8</b>	0	0	0

**Opto-coupler:** 1 = Voltage present (opto-coupler driven) 0 = No voltage (opto-coupler not driven)

**Control (P6) In:** 1 = High (FALSE), (control line open) 0 = Low (TRUE), (control line held to ground)

- Code A can be set from “0” to “10”.
- Code B can be set from “0” to “8”, if a second code is required. If Code B is to be used, Code A must be set to something other than “0”.
- Set Code B to “0” when only one code is required.
- If Code A is set to “0”, “9”, or “10”, then ensure that Code B is set to “0”.

**NOTE:** If Format Code 1 (CTRL 1-1-1) is selected, and no connector is attached to the REMOTE IN connector (P6), then the ES Mode will enable and decode at all times since the inputs are pulled up by internal resistors.

- Direct connection to the REMOTE IN connector (P6) can be made via a dry contact closure.
- The DTS-ES “REMOTE IN” connector (P6) monitors the format indicator LED line of the CP. This allows the DTS-ES to automatically go into the ES Mode when the CP is in a digital sound format.

## 4.2. SETUP WITH A DTS-6AD CINEMA PROCESSOR

### Equipment needed

- SPL meter (set to C-weighting & slow response)
- Multimeter
- RTA
- Calibrated microphones w/multiplexer
- ES Setup Disc
- DTS Technician's kit
- Encoded surround film with DTS timecode and matching DTS disc.

### Audio Setup

1. Turn off the Left, Center, Right, and Subwoofer amplifiers. Place multiplexer in auditorium as directed by manufacturer. Or, see diagram below:

### SUGGESTED MICROPHONE PLACEMENT

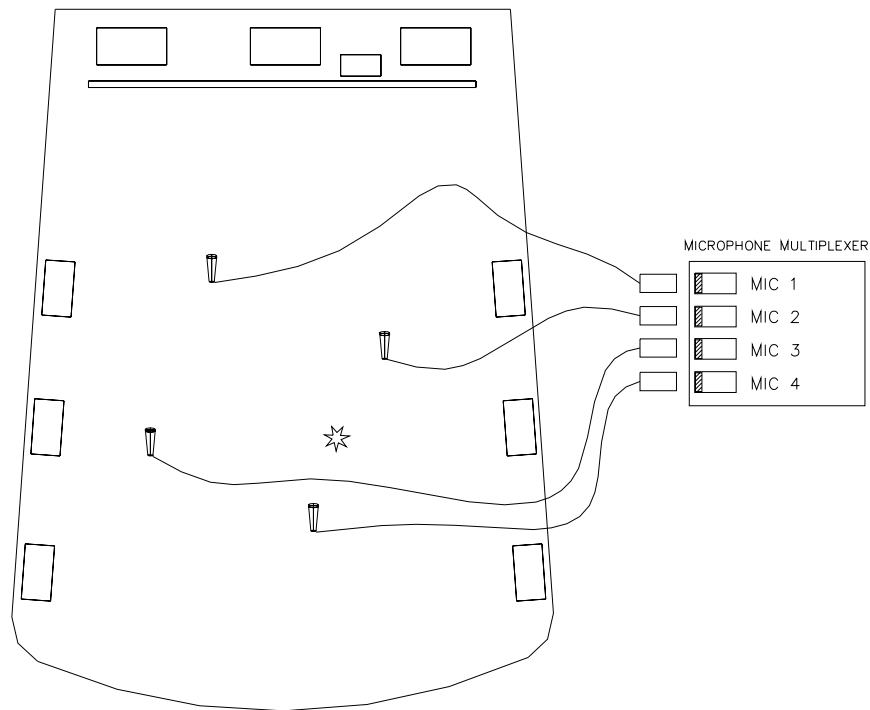

★ MAKE ALL SPL READINGS AT THIS LOCATION.  
IF USING A SINGLE CALIBRATED MICROPHONE FOR  
ADJUSTING EQ, LOCATE THE MIC AT THIS LOCATION.

THEATER.DWG

- Power off the DTS-ES.
- Store the DTS-6AD EQ settings of all channels. In the unlikely event of setup difficulties, these setting may need to be restored. To **store**, press MENU → SYSTEM SETUP → AUDIO → LOAD/STORE.

LOAD/STORE Screen >



- Save existing settings in an unused “store” file. This will allow saving “normal” 5.1 setup and, in most cases, it will be in Setup #2. Setup #1 can then be kept for saving “ES” Mode. This would be ideal since once the ES is installed, it will most likely be a permanent addition to the B-chain.
- If no vacant “store” file exists, then choose which stored settings to download onto a computer and, once done, delete it from the DTS-6AD Store Setup file. Then, use that emptied setup file to store “ES” Mode settings.

- On the DTS-6AD, reset the surround channel’s EQ adjustments. Press MENU → SYSTEM SETUP → AUDIO → CLEAR EQ.

CLEAR EQ SETTINGS screen >

Clear the LEFT SURROUND and RIGHT SURROUND EQ settings.

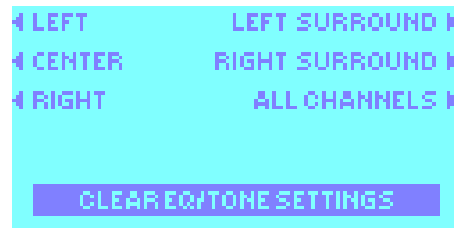

- Once cleared, the EQ settings for LEFT SURR and RIGHT SURR should look:

Single octave adjustment screen >

Should look flat, at “0” for both LEFT SURR and RIGHT SURR. Check both channels.

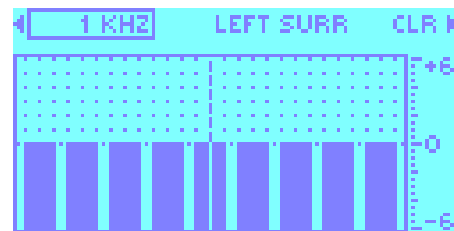

- Press OK to save settings. Press FMT to return to normal operating screen. Surround EQ will be done with ES Setup Disc and DTS-ES unit.

6. Load the ES Setup Disc into the DTS-6AD. Play the **1kHz tone**. Set the LEFT SURROUND and RIGHT SURROUND trim-pots until an output of **300mV** is achieved at P2 “TO POWER AMPS” on the DTS-6AD. Do not adjust the output levels of any other channels.

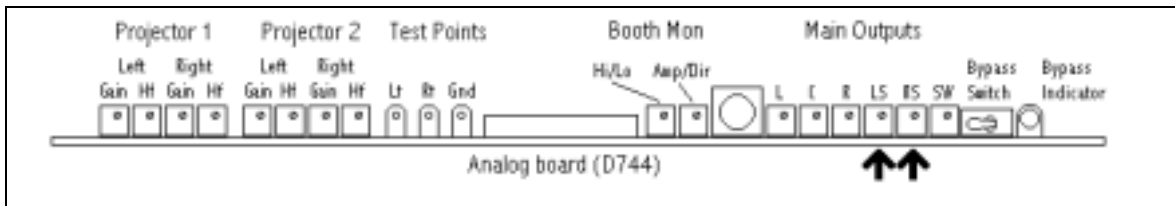

**NOTE:** If the output levels were much lower than 300mV initially, then first turn the gain down on the Left Surround and Right Surround amplifiers, and then set the surround levels to 300mV.

7. Power on the DTS-ES and set it to the BYPASS Mode (Menu #1). The DTS-ES STATUS L.E.D. should extinguish.
8. For this stage of **SPL** adjustments, load the **ES Setup Disc** and adjust the **amplifier gain controls** to set levels. Do NOT adjust levels on the DTS-6AD. Disconnect or turn off appropriate amplifiers to ensure that SPL adjustments are set with only the correct speaker arrays.

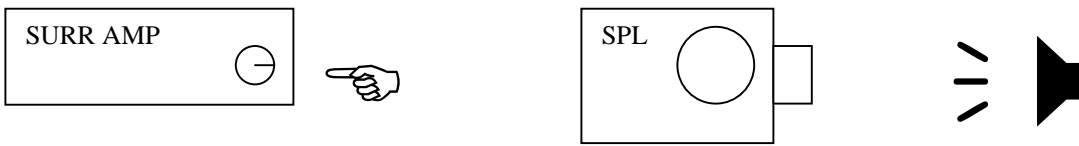

- Play ES disc **LS** pink noise and adjust the **Left Wall Surround** amp for **82 dBC** (SPL) in the theater.
  - Play ES disc **LS** pink noise and adjust the **Left Back Surround** amp for **79 dBC** (SPL) in the theater.
  - Play ES disc **RS** pink noise and adjust the **Right Wall Surround** amp for **82 dBC** (SPL) in the theater.
  - Play ES disc **RS** pink noise and adjust the **Right Back Surround** amp for **79 dBC** (SPL) in the theater.
9. Set DTS-ES to **NORMAL** (Menu #1) and **ES Mode** (Menu #3). DTS-ES STATUS LED should illuminate green.
10. Verify SPL for the Left Wall Surrounds and Right Wall Surrounds outputs have not changed.
- If 1 to 3 dB low, use their amplifier gain controls to bring them up to **82dB**.
  - If amplifier gain is increased, be aware that during BYPASS, the output for that channel will be higher by the amount of the adjustment.
  - If any level is more than 2dB too high, its best to use the DTS-ES Master or individual channel volume **trims** (Audio Setup #1, #2, #3) to attenuate output as needed. This ensures correct playback at normal level during BYPASS Mode.
  - The DTS-ES is designed for unity gain, therefore level differences greater than 3dB between BYPASS and either the ES or Stereo Modes, indicates an error in setup or unit malfunction.
11. Play ES disc **BS** pink noise and verify the **Back Surround** (both the Left Back and Right Back Surrounds) SPL is **82 dBC**.

12. Using the DTS-ES unit, adjust the Bass, Treble, and one-octave EQ for the Left (wall), Right (wall), and Back Surround channels so they achieve the correct pattern on the RTA, as shown below.

**Standard X-curve Pattern**

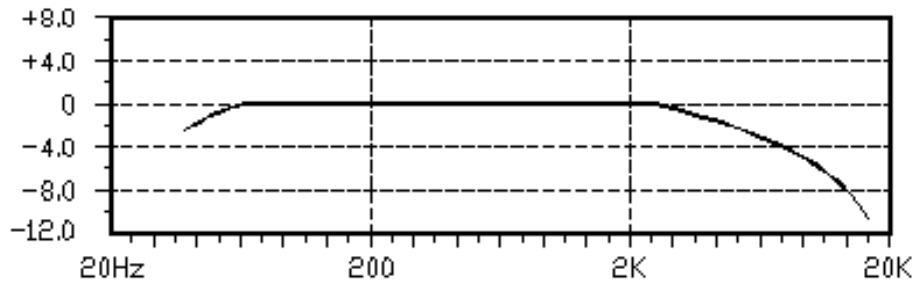

- Start with the Left (wall) Surround. Play ES Setup Disc **LS** pink noise. Enter the ES Audio Setup #6 and set the bass and treble coarse EQ adjustments.

**ES Audio Setup # 6**

```
Left Surround Ch tone:
EXIT ba:+00dB tr:+00dB
```

- Fine tune the Left Surround by going to ES Audio Setup #7.

**ES Audio Setup # 7**

```
Left Surround Ch EQ:
EXIT +0+0+0+0+0+0+0+0+0
```

- Repeat for the Right (wall) and Back Surround channels. Use ES Setup Disc **RS** pink noise for the Right (wall) Surrounds and the **CS** pink noise for the Back (center) Surrounds.

13. When EQ for all channels is finished, save the ES Mode settings for EQ, Tone, Volume, and Delay by entering the Save Audio Setting screen. Press ENTER to save settings.

**Save ES Audio Settings**

```
ENTER to save EQ, Tone &
Vol., Delay for ES mode.
```

14. Set the DTS-ES to **STEREO** Mode (Menu #3).
15. Using the **ES Setup Disc**, set Stereo Mode levels.

- Play **LS** pink noise and verify the Left Surround SPL is **82 dBC**
  - Play **RS** pink noise and verify the Right Surround SPL is **82 dBC**
  - If the level is too high, use the DTS-ES STEREO master or individual level trims to attenuate.
  - If the levels are too low, increase gain at the power amps. Once finished, switch back to the ES Mode and trim those levels (via DTS-ES menu). Re-save the ES settings once completed.
16. After Stereo Mode levels are set, adjust the Tone and EQ for the Left Surround and Right Surround channels so they achieve the correct pattern on the RTA, as shown below:

### Standard X-curve pattern

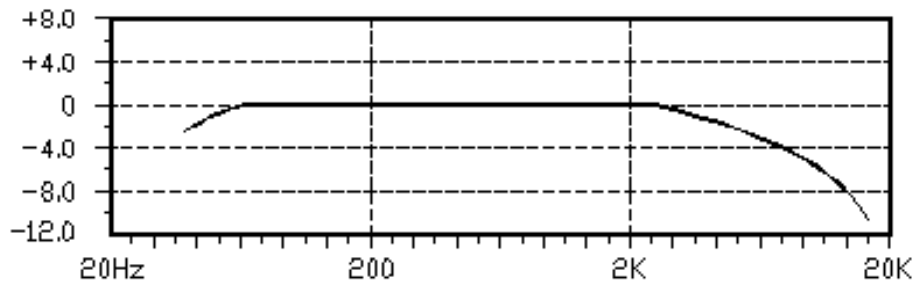

- Start with the Left Surround. Play ES Setup Disc **LS** pink noise. Enter Stereo Setup #4 and set the bass and treble coarse EQ adjustments.

#### Stereo Setup # 4

```
Left Surround Ch tone:
EXIT ba:+00dB tr:+00dB
```

- Fine-tune the Left Surround EQ by going to Stereo Setup #5.

#### Stereo Setup # 5

```
Left Surround Ch EQ:
EXIT +0+0+0+0+0+0+0+0+0+0
```

- Repeat for Right Surround. Use the ES Setup Disc **RS** pink noise and the Stereo Setups #6 & #7.

17. When EQ for all channels is finished, save the Stereo settings for EQ, Tone, and Volume by entering the “Save Stereo Settings” screen. Press ENTER to save settings.

#### Save Stereo Settings

```
ENTER to save EQ, Tone &
Volume for Stereo mode.
```

18. If the **F120 timecode** TC “Y” adapter cable is installed and the **DTS-6AD** is the **ONLY digital sound source**, activate the TC monitoring system. Use the F115 automation interface board and connect it as shown in Section 5.
- Set Analog Output Mode to “MANUAL” (Menu #1) to set menus.
  - Set ES Code to “AUTO” (Menu #2).

- Set Surround Mode to “ES” (Menu #3).
  - If using timecode, set “TC” to “Yes” (Menu #9). Codes A & B are not used.
  - **If not using timecode**, set “TC” to “No” and Menu #9 **Code A to “05” and Code B to “00”**.
    - ⊗ Code A monitors STATUS 5 OUT (P15/16, pin 19) on the DTS-6AD and when it (DTS DIGITAL) goes low, the DTS-ES unit should automatically start ES decoding.
    - ⊗ Code B is not used.
  - Set Analog Output Mode to “NORMAL” (Menu #1) for operation.
19. If using Dolby Digital™ **Model DA20** with the DTS-6AD, use the F115 automation interface board. Connect as shown in Section 5.
- Set Analog Output Mode to “MANUAL” (Menu #1) to set menus.
  - Set ES Code to “AUTO” (Menu #2).
  - Set Surround Mode to “ES” (Menu #3).
  - If using timecode, set “TC” to “Yes” (Menu #9). Codes A & B are not used.
  - **If not using timecode**, set “TC” to “No” and Menu #9 **Code A to “05” and Code B to “03”**.
    - ⊗ Code A monitors STATUS 5 OUT (P15/16, pin 19) on the DTS-6AD and when it goes low (DTS DIGITAL), the DTS-ES unit should automatically start ES decoding.
    - ⊗ Code B monitors STATUS 4 OUT (P15/16, pin 18) on the DTS-6AD and when it goes low (EXTERNAL for DA20), the DTS-ES unit should automatically start ES decoding.
  - Set Analog Output Mode to “NORMAL” (Menu #1) for operation.
20. **If using the ES-1 Setup disc that lists “BACKDRAFT” and “FAR AND AWAY” on it’s label**, load it into the DTS player. Thread the “BUZZ AND BILL SHOW” film. Turn off the subwoofer amplifier. Only “BACKDRAFT” and “FAR AND AWAY” scenes will play in the ES Mode.
- Play the film. Verify the film plays in DTS DIGITAL (Format 5) on the DTS-6AD. Also verify the DTS-ES unit automatically switches to the ES Mode (the front panel L.E.D. should glow green signifying the ES Mode is enabled).
  - When in the ES Mode, verify dialog is heard in the Back Surrounds with the music playing from the Left (wall) and Right (wall) Surrounds.
  - Switch the DTS-ES to Stereo Mode (Menu #3) and verify the front panel L.E.D. glows red. Listen to verify that music and dialog are heard from both surrounds, and that surround loudness has not changed.
  - Switch the DTS-ES to BYPASS (Menu #1) and verify the front panel L.E.D. extinguishes. Listen to verify that dialog is heard from the front speakers and music in the surrounds. Be aware that when in BYPASS, the EQ and trims are disabled. Therefore, the sound quality and loudness of the surrounds will change slightly. BYPASS is used only in the event of DTS-ES unit failure.
  - Switch the DTS-ES back to NORMAL (Menu #1).
21. If using any **other version ES Setup disc**, thread encoded-surround film (that has DTS timecode) and load the matching disc into the DTS-6AD player. **The film title on the disc must have a 5-digit serial number.**
- Play the film. Verify the film plays in DTS DIGITAL (Format 6) on the DTS-6AD. Also verify the DTS-ES unit automatically switches to the ES Mode (the front panel L.E.D. should glow green signifying the ES Mode is enabled).
  - When in the ES Mode, verify good sound quality and that sound is coming from all the surround speakers.

- Switch the DTS-ES to Stereo Mode (Menu #3) and verify the front panel L.E.D. glows red. Listen to verify that sound is heard from both surrounds and that surround loudness has not changed.
  - Switch the DTS-ES to BYPASS (Menu #1) and verify the front panel L.E.D. extinguishes. Listen to verify that sound is heard in both surrounds and is of good quality. Be aware that when in BYPASS, the EQ and trims are disabled. Therefore, the sound quality and loudness of the surrounds will change slightly. BYPASS is used only in the event of DTS-ES unit failure.
  - Switch the DTS-ES back to NORMAL (Menu #1).
  - If any listening material is listed on the disc, play it.
22. If an external 6-track source (example: Dolby Model DA10/20) is connected to the DTS-6AD at P8, “6-TRACK ANALOG IN”, play the encoded-surround film with the disc removed from the player. **Verify:**
- ☒ the external source enables
  - ☒ the DTS-6AD switches to EXTERNAL (Format 5)
  - ☒ the DTS-ES unit automatically switches to the ES Mode (front panel L.E.D. glows green signifying the ES Mode is enabled).
23. Run the film again while sitting in the theater. Verify balanced, good sound quality from all surrounds. Set DTS-ES to all three modes (ES, Stereo, Bypass). Verify good sound quality and level balance between modes.
24. The DTS-ES may remain powered and left in the NORMAL mode during standard 5.1 playback. If, however, using with a Dolby Model DA10/20, set the mode to MANUAL to prevent the ES Mode automatically enabling during a Dolby Digital™ show.



### 4.3. SETUP WITH A NON-DTS CINEMA PROCESSOR

#### Equipment needed

- SPL meter (set to C-weighting & slow response)
- Multimeter
- RTA
- Encoded surround film with DTS timecode and matching DTS disc
- Pink noise source for cinema processor
- ES Setup Disc
- Calibrated microphones w/multiplexer
- DTS Technician's kit
- DTS audio breakout board (to measure levels)

#### Audio Setup

1. Turn off the Left, Center, Right, and Subwoofer amplifiers. Place multiplexer in auditorium as directed by manufacturer. Or, see diagram below:

#### SUGGESTED MICROPHONE PLACEMENT

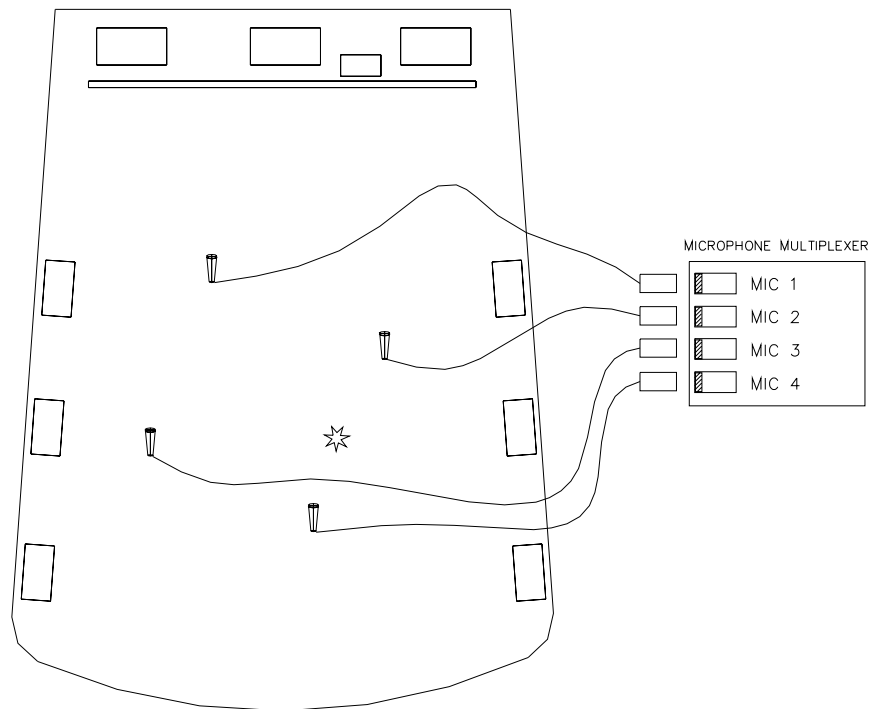

★ MAKE ALL SPL READINGS AT THIS LOCATION.  
 IF USING A SINGLE CALIBRATED MICROPHONE FOR  
 ADJUSTING EQ, LOCATE THE MIC AT THIS LOCATION.

THEATER.DWG

2. Carefully note the EQ settings of the surround channels. In the unlikely event of setup difficulties, these setting may need to be restored.
3. On the cinema processor (CP), turn **surround channel's EQ adjustment pots** to the middle of their rotation. Do not adjust any other channel's EQ pots.
4. Disconnect the DTS player's audio (breakout) board from the cinema processor (CP). Load the **ES Setup Disc** into the DTS player.
  - Play the 1kHz tone. Connect meter to the breakout board and adjust the DTS player's left and right surround output levels for **300mV**. Do not adjust the output levels of any other channels.
  - Set the left surround and right surround outputs on the CP to **300mV**. Do not adjust the output levels of any other channels.

**NOTE:** If the output levels were much lower than 300mV initially, then turn the amplifier gain down first and then turn up the output levels on the CP.
5. Reconnect the DTS breakout board to the CP. Set the DTS-ES to the BYPASS Mode.
6. For this stage of **SPL** adjustments, load the **ES Setup Disc** and adjust the **amplifier gain controls** to set levels. Do NOT adjust levels on the DTS player or CP. Disconnect or turn off appropriate amplifiers to ensure that SPL adjustments are set with only the correct speaker arrays.

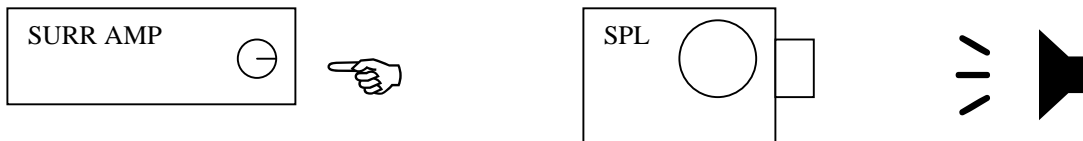

- Play ES disc **LS** pink noise and adjust the **Left Wall Surround** amp for **82 dBC** (SPL) in the theater.
  - Play ES disc **LS** pink noise and adjust the **Left Back Surround** amp for **79 dBC** (SPL) in the theater.
  - Play ES disc **RS** pink noise and adjust the **Right Wall Surround** amp for **82 dBC** (SPL) in the theater.
  - Play ES disc **RS** pink noise and adjust the **Right Back Surround** amp for **79 dBC** (SPL) in the theater.
7. Set DTS-ES to **NORMAL** and **ES Mode**. The ES STATUS L.E.D. should illuminate green.
  8. Play ES disc **LS** pink noise for the Left Wall Surrounds and **RS** for Right Wall Surrounds outputs. Verify no changes in SPL.
    - If 1 to 3 dB low while in ES Mode, use the specific amplifier's gain control to achieve **82dBC**.
    - If amplifier gain is increased, be aware that during BYPASS, the output for that channel will be higher by the amount of the adjustment.
    - If any level is more than 2dB too high, its best to use the DTS-ES Master or individual channel volume **trims** (Audio Setup #1, #2, #3) to attenuate output as needed. This ensures correct playback when switching between BYPASS & ES Modes.
    - The DTS-ES is designed for unity gain, therefore level differences greater than 3dB between BYPASS and either the ES or Stereo Modes, indicates an error in setup or unit malfunction.
  9. Using the ES disc's **BS** pink noise, check the Back Surround Channel (Left and Right Back Surrounds) for **82 dBC** (SPL).

**NOTE:** If using a Pink Noise Generator, feed pink noise to the CP on both the Left and Right Surround outputs. Level should be **85 dBC** (SPL).

10. While in ES Mode, set the DTS-ES Bass, Treble, and one octave EQ for the Left Wall, Right Wall, and Back Surround channels so they achieve the correct pattern on the RTA, as shown below.

### Standard X-curve Pattern

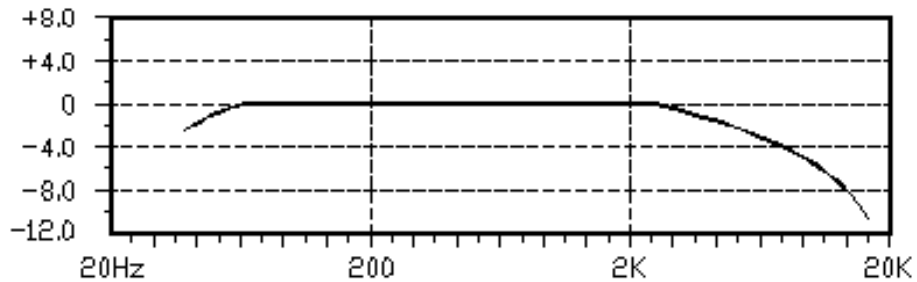

- Start with the Left (wall) Surround. Play ES Setup Disc **LS** pink noise. Enter ES Audio Setup #6 and set the bass and treble coarse EQ adjustments.

#### ES Audio Setup # 6

```
Left Surround Ch tone:
EXIT ba:+00dB tr:+00dB
```

- Fine tune the Left Surround by going to ES Audio Setup #7.

#### ES Audio Setup # 7

```
Left Surround Ch EQ:
EXIT +0+0+0+0+0+0+0+0+0
```

- Repeat for the Right (wall) and Back Surround channels. Use ES Setup Disc **RS** pink noise for the Right (wall) Surrounds and the **CS** pink noise for the Back (center) Surrounds.
11. When EQ for all channels is finished, save the ES Mode settings for EQ, Tone, Volume, and Delay by entering the Save Audio Setting screen. Press ENTER to save settings.

#### Save ES Audio Settings

```
ENTER to save EQ, Tone &
Vol., Delay for ES mode.
```

12. Set the DTS-ES to **STEREO** Mode (Menu #3).
13. Using the **ES Setup Disc**, set Stereo Mode levels.

- Play **LS** pink noise and verify the Left Surround SPL is **82 dBC**
  - Play **RS** pink noise and verify the Right Surround SPL is **82 dBC**
  - If the level is too high, use the STEREO master or individual level trims to attenuate as necessary.
  - If the levels are too low, increase gain at the power amps. Once finished, switch back to the ES Mode and trim those levels. Re-save the ES settings once completed.
14. After Stereo Mode levels are set, adjust the Tone and EQ for the Left Surround and Right Surround channels so they achieve the correct pattern on the RTA, as shown below.

### Standard X-curve pattern

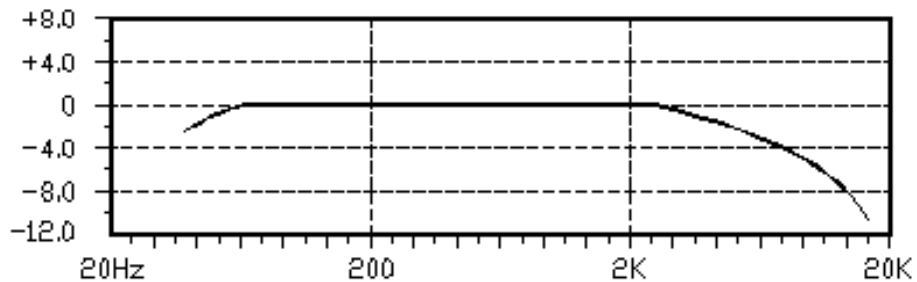

- Start with the Left Surround. Play ES Setup Disc **LS** pink noise. Enter Stereo Setup #4 and set the bass and treble coarse EQ adjustments

#### Stereo Setup # 4

```
Left Surround Ch tone:
EXIT ba:+00dB tr:+00dB
```

- Fine-tune the Left Surround EQ by going to Stereo Setup #5.

#### Stereo Setup # 5

```
Left Surround Ch EQ:
EXIT +0+0+0+0+0+0+0+0+0
```

- Repeat for Right Surround. Use the ES Setup Disc **RS** pink noise and the Stereo Setups #6 & #7.

15. When EQ for all channels is finished, save the Stereo settings for EQ, Tone, and Volume by entering the “Save Stereo Settings” screen. Press ENTER to save settings.

#### Save Stereo Settings

```
ENTER to save EQ, Tone &
Volume for Stereo mode.
```

16. If the **F120 timecode** TC “Y” adapter cable is installed and the **DTS system is the SOLE digital sound** source, activate the TC monitoring system. Use the F115 automation interface board and connect it as shown in Section 5.
- Set Analog Output Mode to “MANUAL” (Menu #1) to set menus.
  - Set ES Code to “AUTO” (Menu #2).

- Set Surround Mode to “ES” (Menu #3).
- Since the **CP50** and **CP100** do not have stereo surrounds, their use with the DTS-ES is not recommended.

**For CP45, CP55 (modified for stereo surrounds), CP65, and UltraStereo, on Menu #9:**

- ✧ If using timecode, set “TC” to “Yes” (Menu #9). Codes A & B are not used.
- ✧ If **not** using timecode, set “TC” to “No”. **Code A** monitors the automation LED lines and is set so that when the “digital” format line goes low, the DTS-ES starts automatically ES decoding. The DA20 and DTS player use the same format on the cinema processors named above. Set Code A to “05”. **Code B** is not used, set it to “00”.

**For CP200, on Menu #9:**

- ✧ If using timecode, set “TC” to “Yes”. Codes A & B are not used.
- ✧ If **not** using timecode, set “TC” to “No”. **Code A** monitors the relay key signal from DTS-6D unit to DTS-D567 interface board. Set Code A to “10”. **Code B** is not used, set it to “00”.

**For CP500, on Menu #9:**

- ✧ If using timecode, set “TC” to “Yes”: Codes A & B are not used.
- ✧ If **not** using timecode, set “TC” to “No”. **Codes A & B** are used to monitor the automation LED lines and are set so that when a “digital” line goes low, the DTS-ES automatically starts ES decoding.
  - **Code A** should be used to monitor the Dolby “digital” status LED. Typically SK4 is assigned to “Dolby Digital” (format 10) on the CP500.
  - **Code B** should be used to monitor DTS “digital” status LED. Typically, SK5 is assigned to “external 6-track”, the CP500 External 6-track Analog Input connector = where the DTS player connects.

**Because the format lines can be reprogrammed by the user, the correct code for each “digital” line must be determined by a process of elimination.**

- ☒ Start by setting **Code A** for “01”. Push on the CP500 sound format button that controls DTS. If the DTS-ES’ STATUS L.E.D. illuminates green then try other format keys. If no other key starts the DTS-ES decoding (green L.E.D.), then keep that setting.
  - ☒ Repeat procedure until the one code is found that corresponds to one (CP500) format button that controls Dolby “digital”.
  - ☒ Repeat for **Code B** for DTS “digital”.
  - ☒ Once code is set, verify pushing other sound format buttons switches the DTS-ES to STEREO (red LED). Make a note of the correct code setting (in case of accidental reset).
- Set Analog Output Mode to “NORMAL” (Menu #1) for automatic ES operation. Leave set to “MANUAL” when automatic operation is not preferred.

17. If the **F120 timecode “Y”** adapter cable is installed and the **DTS system is ONE of the digital sound** sources, activate the TC monitoring system. Use the F115 automation interface board and connect it as shown in Section 5.
- Set Analog Output Mode to “MANUAL” (Menu #1) to set menus.
  - Set ES Code to “AUTO” (Menu #2).
  - Set Surround Mode to “ES” (Menu #3).
- For **CP45, CP55, CP65** and **UltraStereo**: Codes A & B are used by the DTS-ES unit to monitor the CP automation LED lines. When the “digital” format line goes low, the DTS-ES automatically starts ES decoding.
    - ✧ If using timecode, set “TC” to “Yes”. Codes A & B are not used.
    - ✧ If **not** using timecode, set “TC” to “No”. Code A monitors the sound format line for “digital”. Both DTS digital and Dolby digital use the same format. **Set Code A to “05”**. Code B monitors the sound format line for another 6-track digital source requiring ES decoding. **Set Code B to “00”**.
  - The **CP50** and **CP100** require modification to function with the DTS-ES unit. Contact DTS.
  - **CP200** requires special wiring. See Section 5.
  - For **CP500**
    - ✧ If using timecode, set “TC” to “Yes” (Menu #9). Codes A & B are not used.
    - ✧ If **not** using timecode, set “TC” to “No”. Codes A & B must be set so the DTS-ES can monitor the digital format automation LED lines. Code A is used to monitor the DTS Digital line. When it goes low, the DTS-ES unit should automatically start ES decoding. Typically, SK5 is assigned to the CP500 external “6-channel Analog Input” connector where the DTS player is connected. The correct code for this line must be determined and it is a process of elimination. **Code B** is used to monitor the Dolby Digital™ line. When it goes low, the DTS-ES unit should automatically start ES decoding. Typically, SK4 (Format 10) is assigned to the CP500 “digital”.
      - ☒ Start by setting **Code A** for “01”. Push on the CP500 sound format button that controls DTS. If the DTS-ES’s STATUS L.E.D. illuminates green, then try other format keys. If no other key starts the DTS-ES decoding (green L.E.D.), then keep that setting.
      - ☒ Once code is set, verify pushing other sound format buttons switches the DTS-ES to STEREO (red LED). Make a note of the correct code setting (in case of accidental reset).
      - ☒ Repeat procedure code selection for **Code B**, Dolby Digital™.
  - Set Analog Output Mode to “NORMAL” (Menu #1) for operation.
18. If **no “Y” cable** is installed, connect the F115 automation interface board as shown in Section 5. Program “TC” to “No” in Menu # 9.

19. If using the **ES-1 Setup disc**, load it into the DTS player and thread the “BUZZ AND BILL SHOW” film. Turn off the subwoofer amplifier. Be aware that only “BACKDRAFT” and “FAR AND AWAY” scenes will play in the ES Mode.
- Play the film. Verify the film plays in DTS DIGITAL (Format 5) on the DTS-6AD. Also verify the DTS-ES unit automatically switches to the ES Mode (the front panel L.E.D. should glow green signifying the ES Mode is enabled).
  - When in the ES Mode, verify dialog is heard in the Back Surrounds with the music playing from the Left (wall) and Right (wall) Surrounds.
  - Switch the DTS-ES to Stereo Mode (Menu #3) and verify the front panel L.E.D. glows red. Listen to verify that music and dialog are heard from both surrounds, and that surround loudness has not changed.
  - Switch the DTS-ES to BYPASS (Menu #1) and verify the front panel L.E.D. extinguishes. Listen to verify that dialog is heard from the front speakers and music in the surrounds. Be aware that when in BYPASS, the EQ and trims are disabled. Therefore, the sound quality and loudness of the surrounds will change slightly. BYPASS is used only in the event of DTS-ES unit failure.
  - Switch the DTS-ES back to NORMAL (Menu #1).
20. If using any **other version ES Setup disc**, thread encoded surround film (that has DTS timecode) and load the matching disc into the DTS-6AD player. The film title on the disc must have a 5-digit serial number.
- Play the film. Verify the film plays in DTS DIGITAL (Format 6) on the DTS-6AD. Also verify the DTS-ES unit automatically switches to the ES Mode (the front panel L.E.D. should glow green signifying the ES Mode is enabled).
  - When in the ES Mode, verify good sound quality and that sound is coming from all the surround speakers.
  - Switch the DTS-ES to Stereo Mode (Menu #3) and verify the front panel L.E.D. glows red. Listen to verify that sound is heard from both surrounds and that surround loudness has not changed.
  - Switch the DTS-ES to BYPASS (Menu #1) and verify the front panel L.E.D. extinguishes. Listen to verify that sound is heard in both surrounds and is of good quality. Be aware that when in BYPASS, the EQ and trims are disabled. Therefore, the sound quality and loudness of the surrounds will change slightly. BYPASS is used only in the event of DTS-ES unit failure.
  - Switch the DTS-ES back to NORMAL (Menu #1).
21. If using with external 6-track source is connected to P8, “6-TRACK ANALOG IN”, on the DTS-6AD, play the encoded surround film with the disc removed from the player. Verify:
- ① the external source enables
  - ② the DTS-6AD switches to EXTERNAL (Format 5)
  - ③ the DTS-ES unit automatically switches to the ES Mode (front panel L.E.D. glows green signifying the ES Mode is enabled).

22. Run the film again while sitting in the theater. Verify balanced, good sound quality from all surrounds. Set DTS-ES to all three modes (ES, Stereo, Bypass). Verify good sound quality and level balance between surround modes.
23. The DTS-ES may remain powered and left in the NORMAL mode during standard 5.1 playback. If, however, using with a Dolby Model DA10, set the mode to MANUAL to prevent the ES Mode automatically enabling during a Dolby Digital™ show.

#### **4.4. COM (RS232) CONNECTOR**

This connector is used to download/upload settings from the DTS-ES unit to a laptop computer. Special software, available from DTS, is required. When done, a “standard” null modem cable will have to be modified. The pin-out of this connector given in Section 5.

#### **4.5. EVENT OUT CONNECTOR (after year 2000, this feature available via special order only)**

This is used to connect to special effects such as key contacts to lasers or strobes.

To test, connect the DTS-ES to the effects and do a run-through of the show. If effects are not available, connect an ohmmeter and check the program contact closures.

- A closure will occur as programmed on the show disc or by the user. Timecode is used as the marker of when an event will occur. The program on the disc determines the length of time a closure is held. Or, if events are programmed by the user, the user may modify the closure time.



## SECTION 5                      DIAGRAMS

**Rear panel connector pin-outs.** As looking from the rear panel, in order from left to right.

### REMOTE IN (P6, DB9 Female)

<i>PIN #</i>	<i>DESCRIPTION</i>
1	Fader In
2	N.C.
3	Control 1 In
4	Control 2 In
5	Control 3 In
6	Digital Ground
7	Digital Ground
8	Digital Ground
9	Digital Ground

### COM (RS232) (P5, DB9 Male)

<i>PIN #</i>	<i>DESCRIPTION</i>
1	N.C.
2	TXD
3	RXD
4	N.C.
5	Digital Ground
6	N.C.
7	N.C.
8	N.C.
9	N.C.

### TIMECODE IN (P4, DB9 Female)

<i>PIN #</i>	<i>DESCRIPTION</i>
1	TC In from projector 1
2	TC In from projector 2
3	N.C.
4	N.C.
5	N.C.
6	Digital Ground
7	Digital Ground
8	N.C.
9	N.C.

### EVENT OUT (P3, DB15 Female)

<i>PIN #</i>	<i>DESCRIPTION</i>
1	Event 1 Output Common
2	Event 2 Output Common
3	Event 3 Output Common
4	Event 4 Output Common
5	Event 5 Output Common
6	Event 6 Output Common
7	Event 7 & 8 Output Common
8	Event 8 Output
9	Event 1 Output
10	Event 2 Output
11	Event 3 Output
12	Event 4 Output
13	Event 5 Output
14	Event 6 Output
15	Event 7 Output

**After year 2000, EVENTS feature available via special order only.**

### ANALOG OUT (P2, DB15 Male)

<i>PIN #</i>	<i>DESCRIPTION</i>
1	Left Wall Surround Out
2	Right Wall Surround Out
3	Left Back Wall Surround Out
4	Right Back Wall Surround Out
5	Common
6	Common
7	Auxiliary Left Out
8	N.C.
9 - 15	Common

### ANALOG IN (P1, DB9 Female)

<i>PIN #</i>	<i>DESCRIPTION</i>
1	N.C.
2	Right Surround
3	N.C.
4	Left Surround
5	N.C.
6	Common
7	N.C.
8	N.C.
9	Common

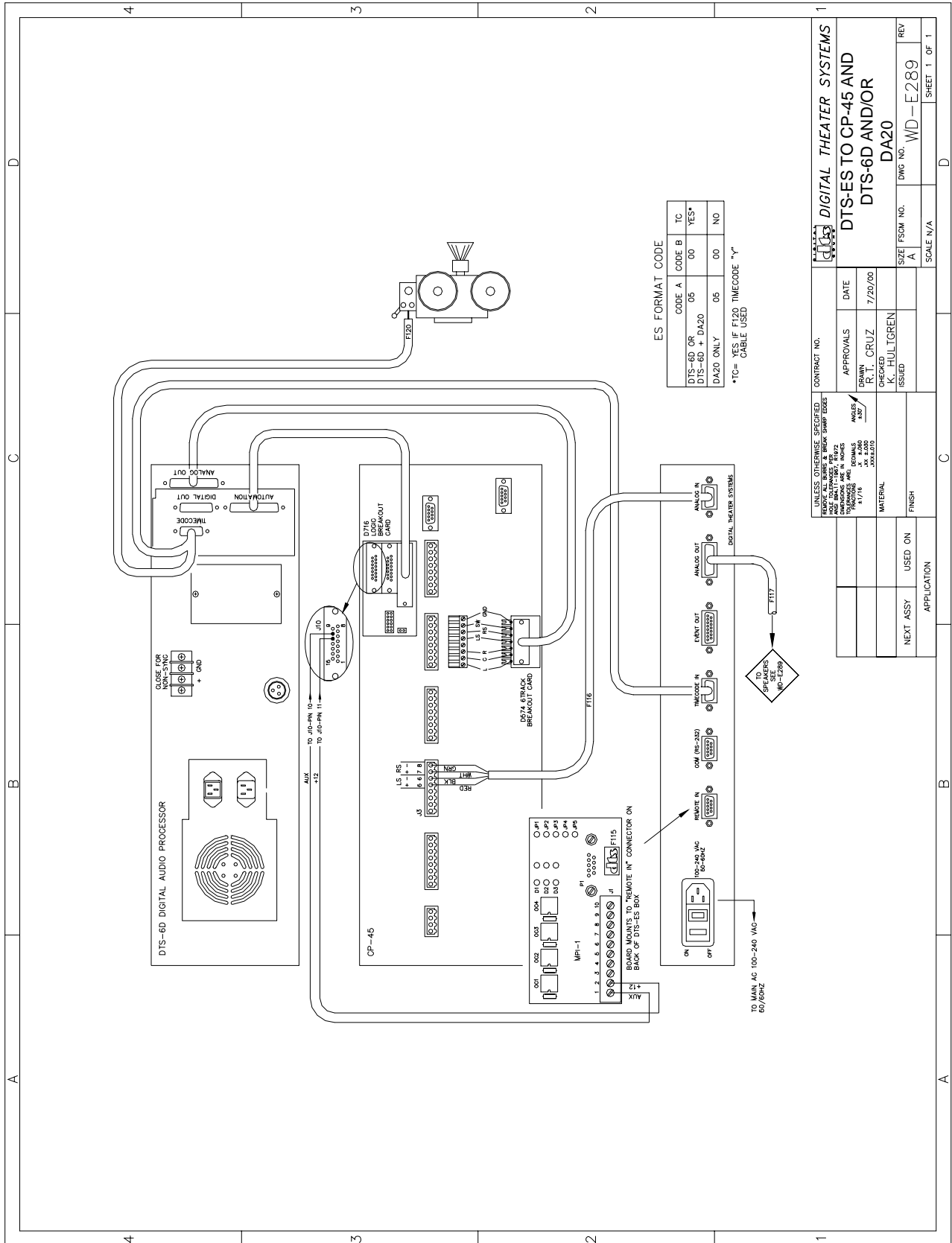

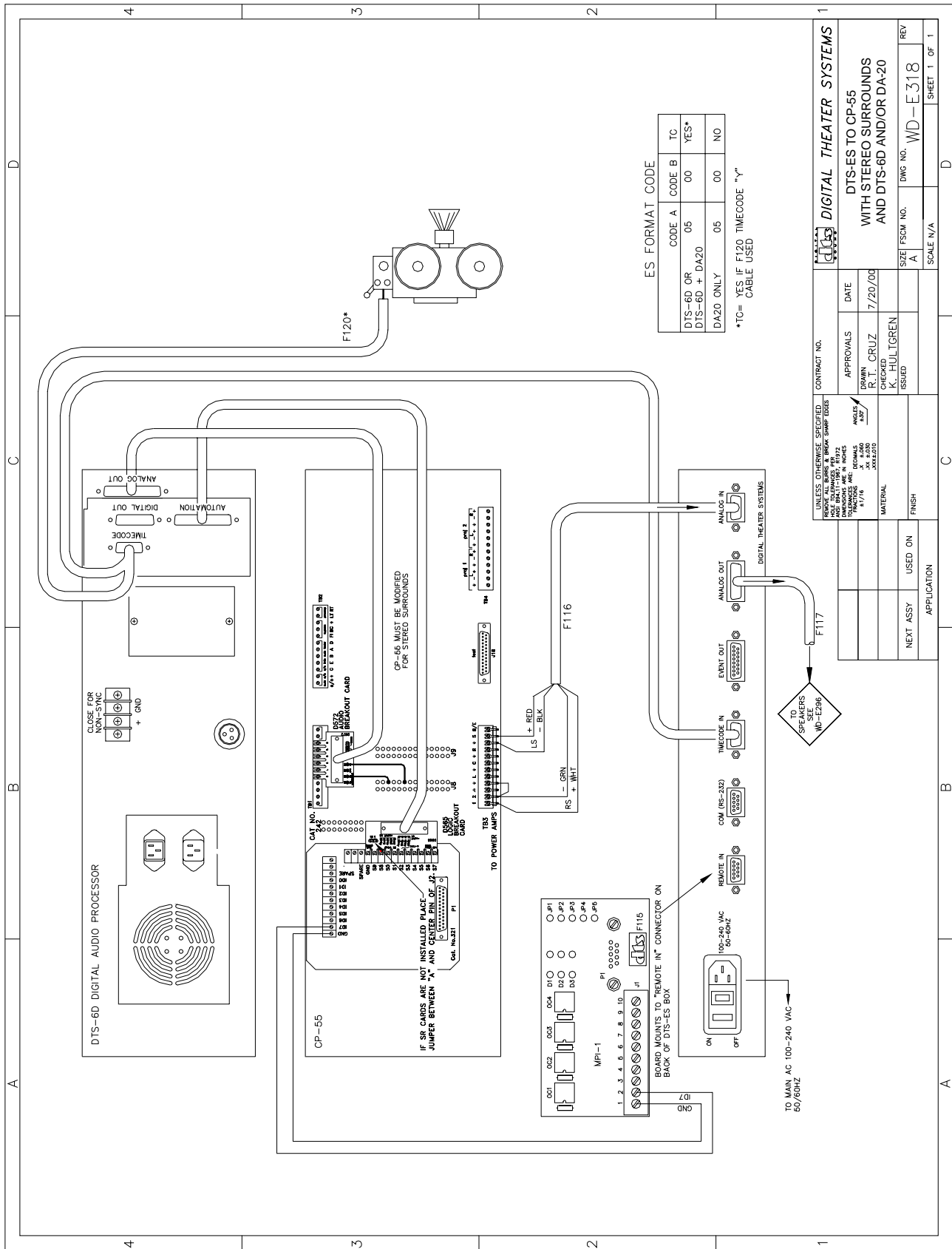

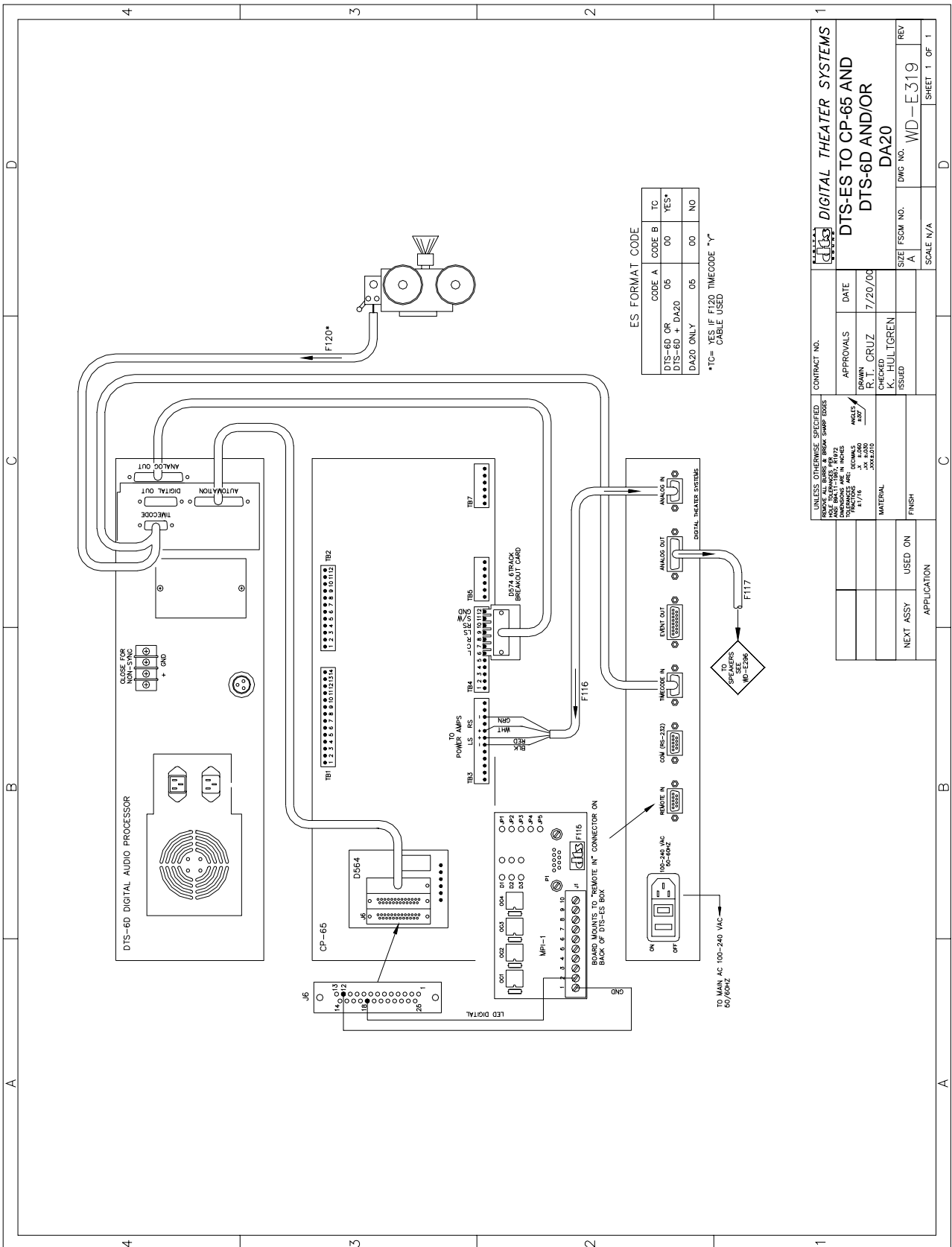

ES FORMAT CODE

CODE A	CODE B	TC
DTS-6D OR DA20	00	YES*
DA20 ONLY	05	NO

\*TC= YES IF F120 TIMECODE "Y"  
CABLE USED

UNLESS OTHERWISE SPECIFIED REMOVE ALL BURRS & BREAK SHARP EDGES AND BRITISH STANDARDS BS 1972		CONTRACT NO.	1
APPROVALS	DATE	DIGITAL THEATER SYSTEMS	
DRAWN R. T. CRUZ	7/20/00	DTS-ES TO CP-65 AND DTS-6D AND/OR DA20	
CHECKED K. HULTGREN		SIZE	FSCM NO. WJ-E319
ISSUED		REV	REV
MATERIAL		SCALE	N/A
FINISH		SHEET 1 OF 1	

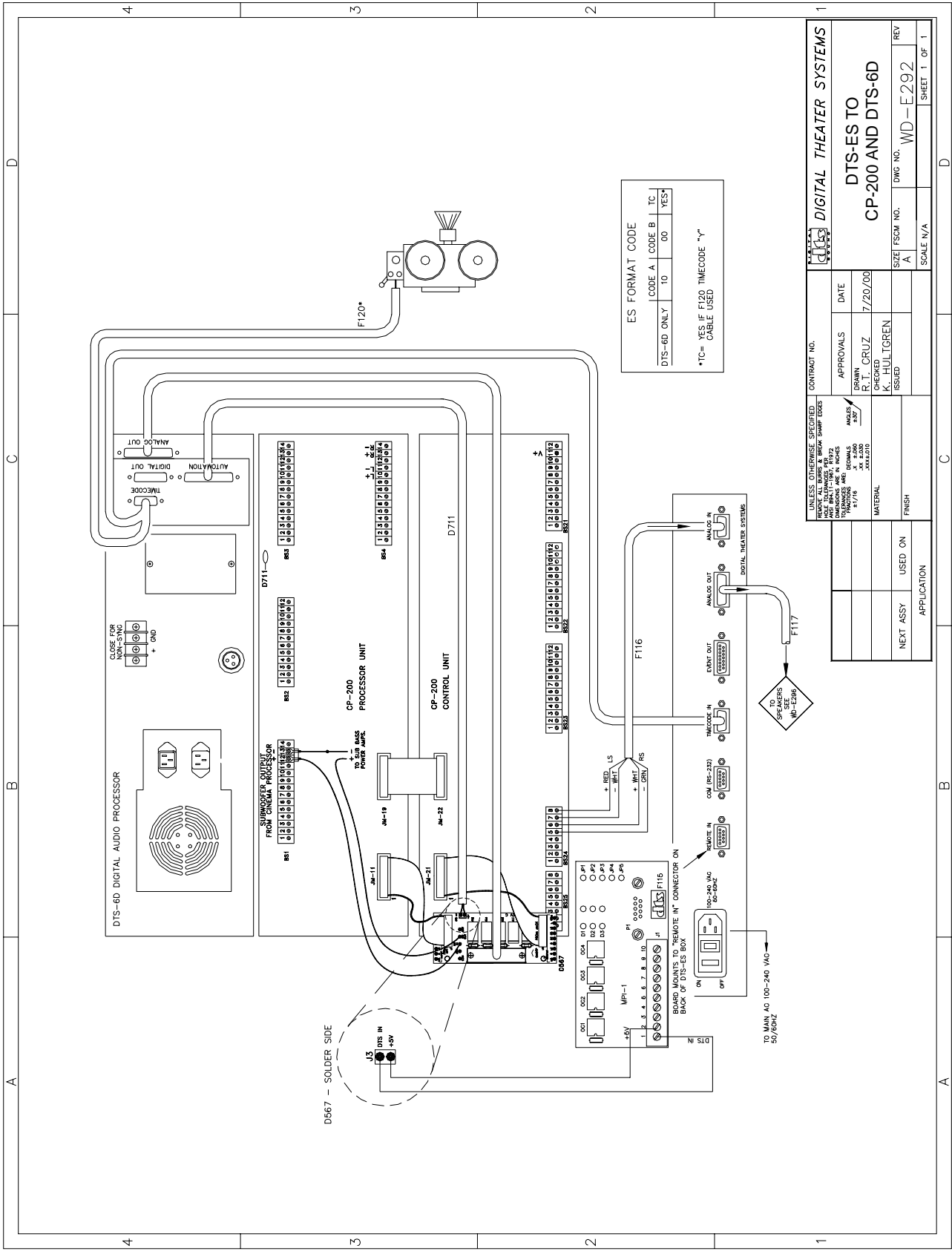

ES FORMAT CODE  
 CODE A I CODE B I TC I  
 DTS-6D ONLY TO 00 YES-  
 \*TC= YES IF F120 TIMECODE "Y"  
 CABLE USED

UNLESS OTHERWISE SPECIFIED, ALL DIMENSIONS ARE IN INCHES. DECIMALS ARE IN INCHES. DIMENSIONS ARE IN INCHES. DIMENSIONS ARE IN INCHES. DIMENSIONS ARE IN INCHES.		CONTRACT NO.	
APPROVALS	DATE	DIGITAL THEATER SYSTEMS	
DRAWN BY CRUZ	7/20/00	DTS-ES TO	
CHECKED BY K. HULLIGREN		CP-200 AND DTS-6D	
ISSUED		SIZE	FSCM NO. WD-E292
		SCALE	N/A
		REV	SHEET 1 OF 1

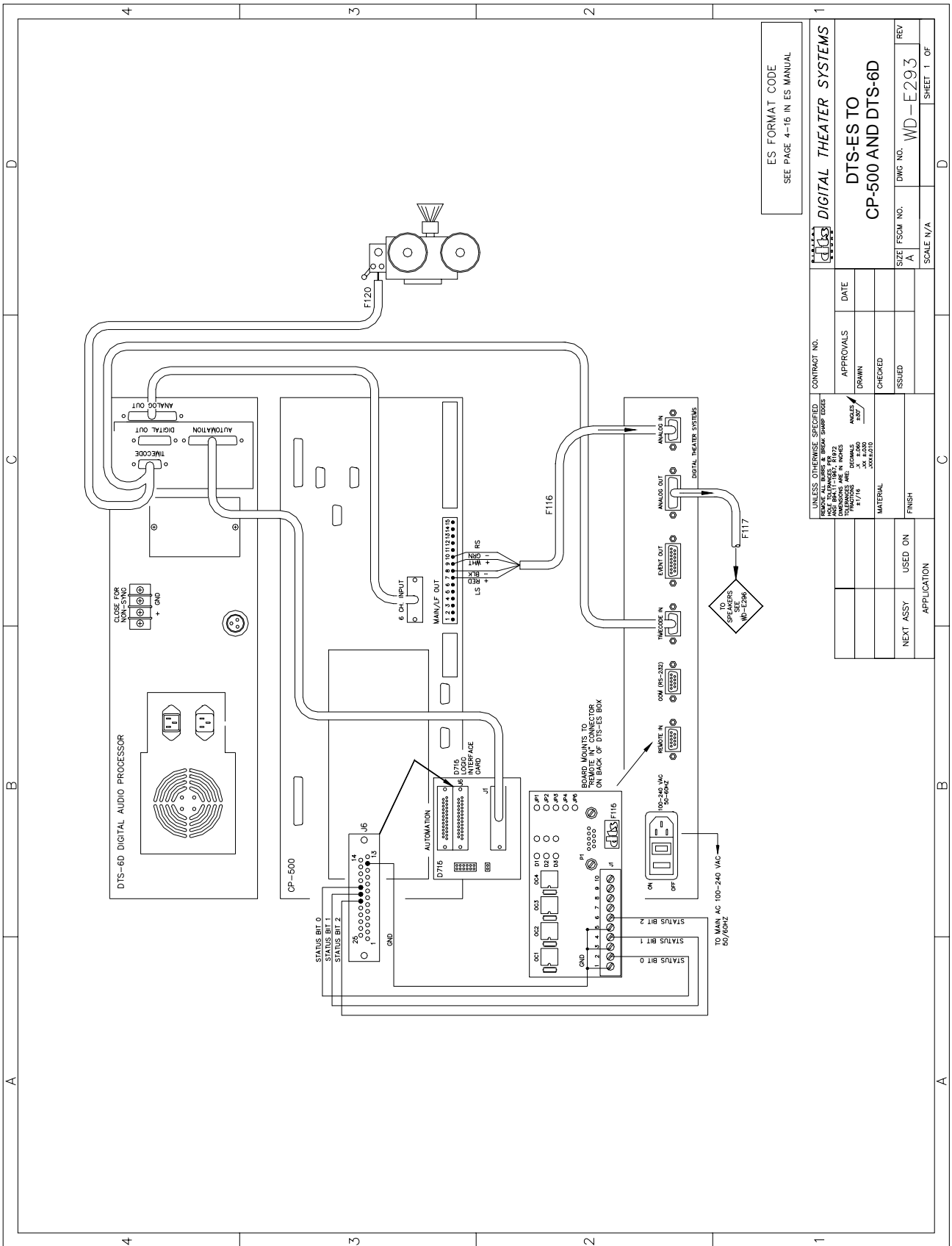

ES FORMAT CODE  
SEE PAGE 4-16 IN ES MANUAL

<b>DTS</b>		<b>DIGITAL THEATER SYSTEMS</b>	
CONTRACT NO.		DATE	
UNLESS OTHERWISE SPECIFIED, DIMENSIONS ARE IN INCHES. DIMENSIONS ARE TO CENTER UNLESS NOTED OTHERWISE.		APPROVALS	
DRAWN: [Signature]		CHECKED: [Signature]	
MATERIAL		ISSUED: [Signature]	
FINISH		SCALE N/A	
NEXT ASSY		USED ON	
APPLICATION		REV	
DTS-ES TO CP-500 AND DTS-6D		DWG NO. WD-E293	
SIZE FSDM NO. A		SHEET 1 OF 1	

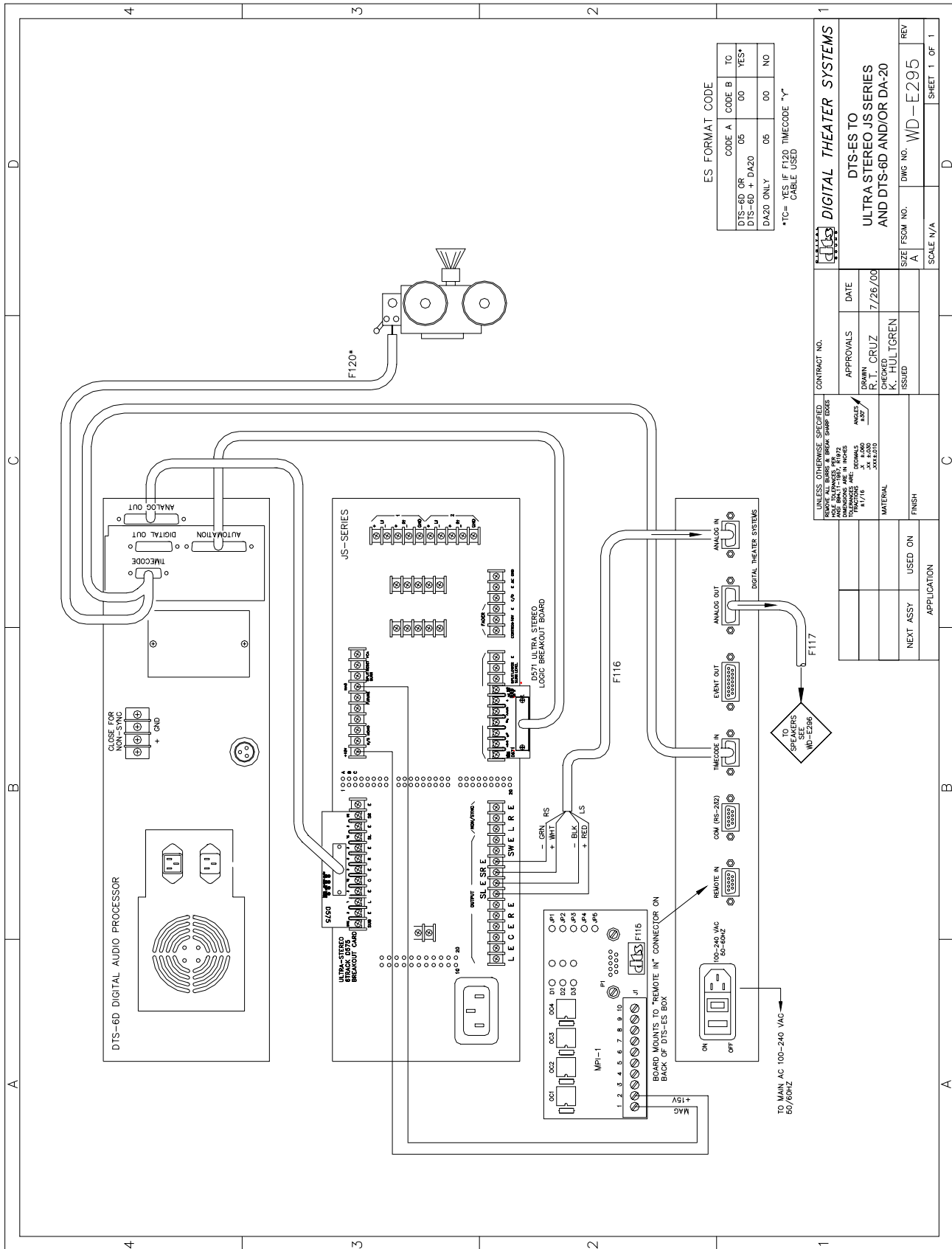

ES FORMAT CODE

CODE A	CODE B	TC
DTS-6D OR	05	00
DTS-6D + DA20	00	00
DA20 ONLY	05	00
	00	NO

\*TC= YES IF F120 TIMECODE "Y"  
CABLE USED

UNLESS OTHERWISE SPECIFIED REMOVE ALL BURRS & BREAK SHARP EDGES AND FINISH TO 100 MICRONS (4 MIL) INCHES (25.4 MICRONS) MAX. SURFACE FINISH: 320 RA		CONTRACT NO.
APPROVALS	DATE	
DRAWN R. T. CRUZ	7/26/00	
CHECKED K. HULTGREN		
ISSUED		
MATERIAL		
FINISH		
APPLICATION		
NEXT ASSY	USED ON	
SCALE N/A	SIZE FSCOM NO. A	WD-E295
	SCALE N/A	SHEET 1 OF 1

DIGITAL THEATER SYSTEMS	
DTS-ES TO ULTRA STEREO JS SERIES AND DTS-6D AND/OR DA-20	
SIZE FSCOM NO. A	WD-E295
SCALE N/A	SHEET 1 OF 1

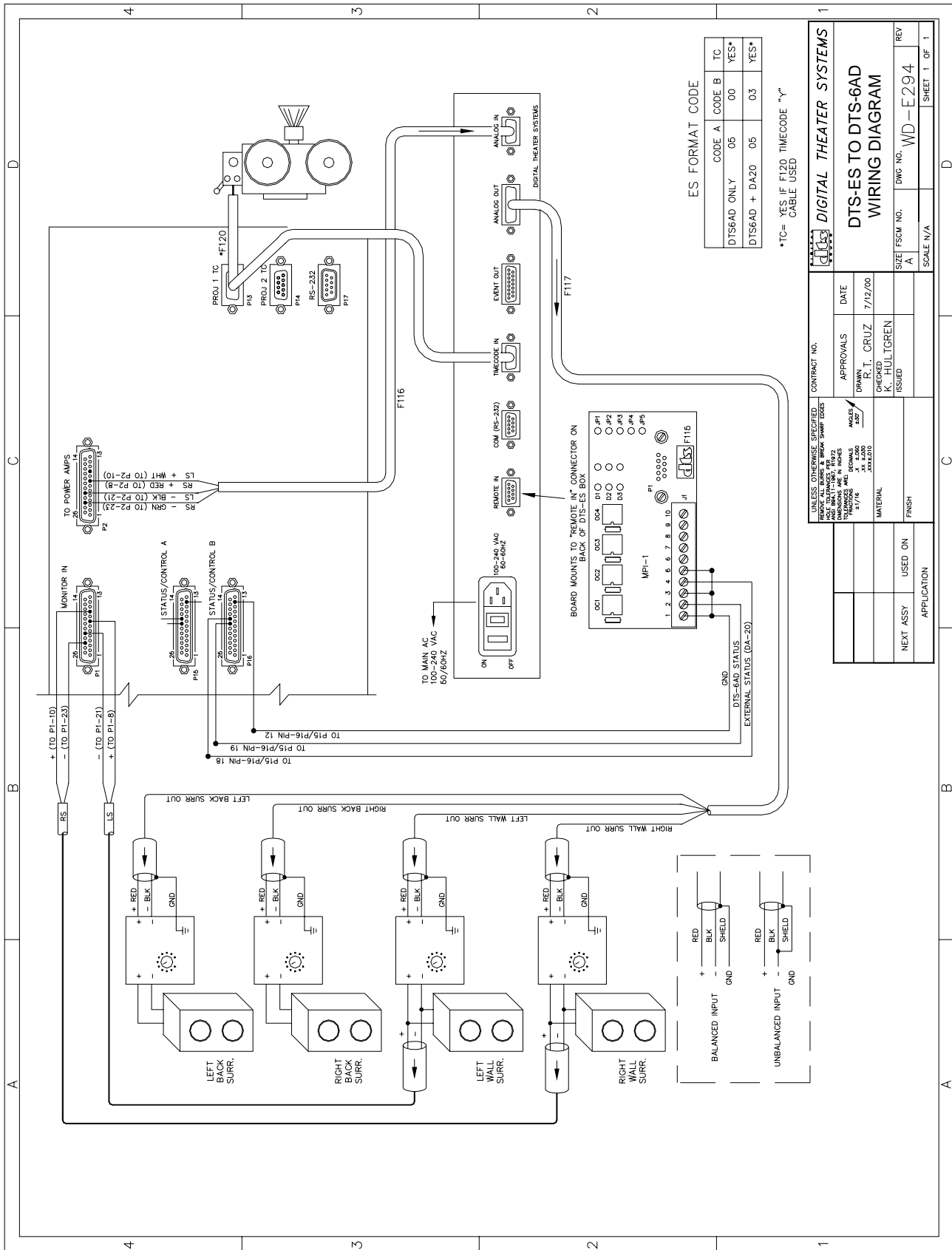



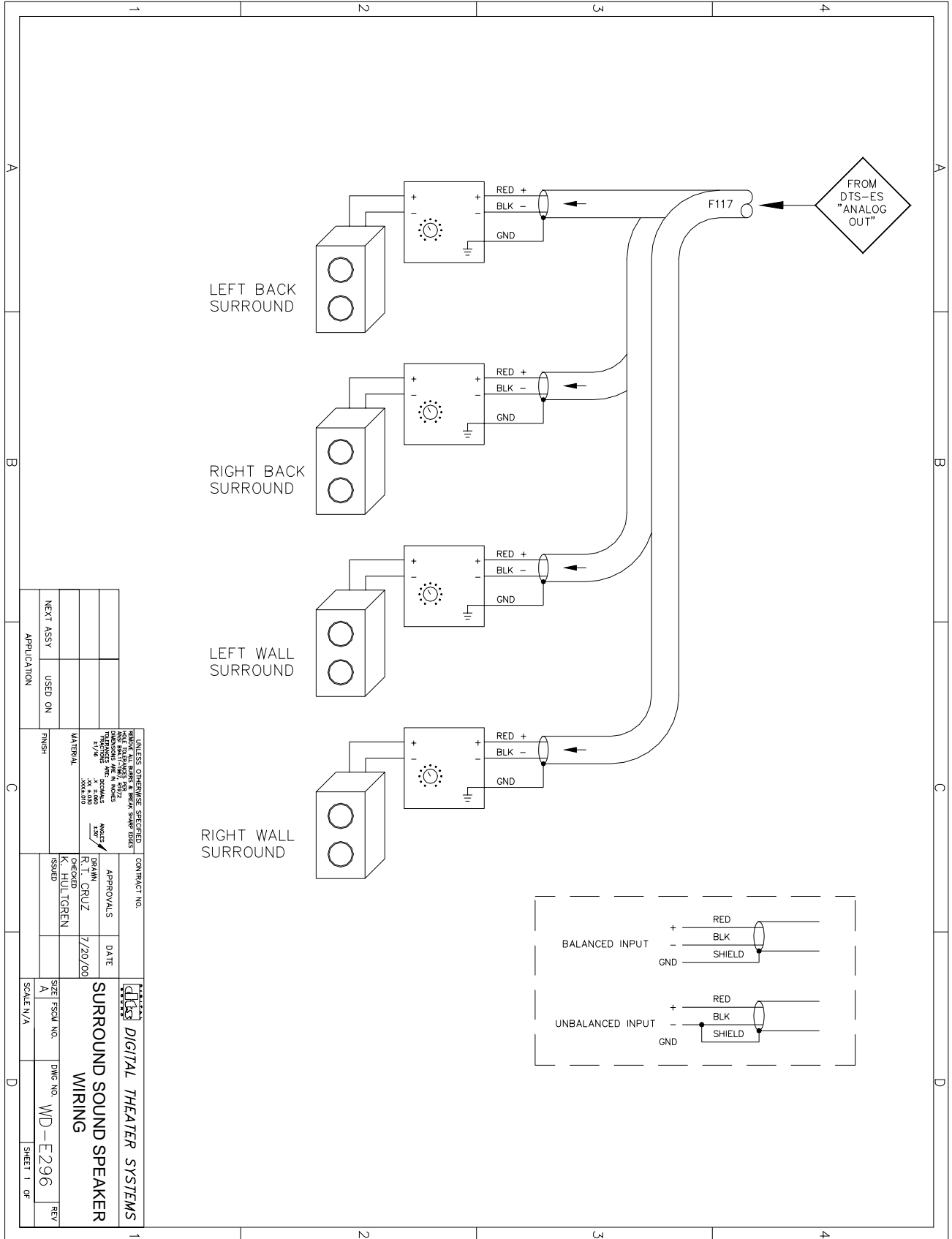

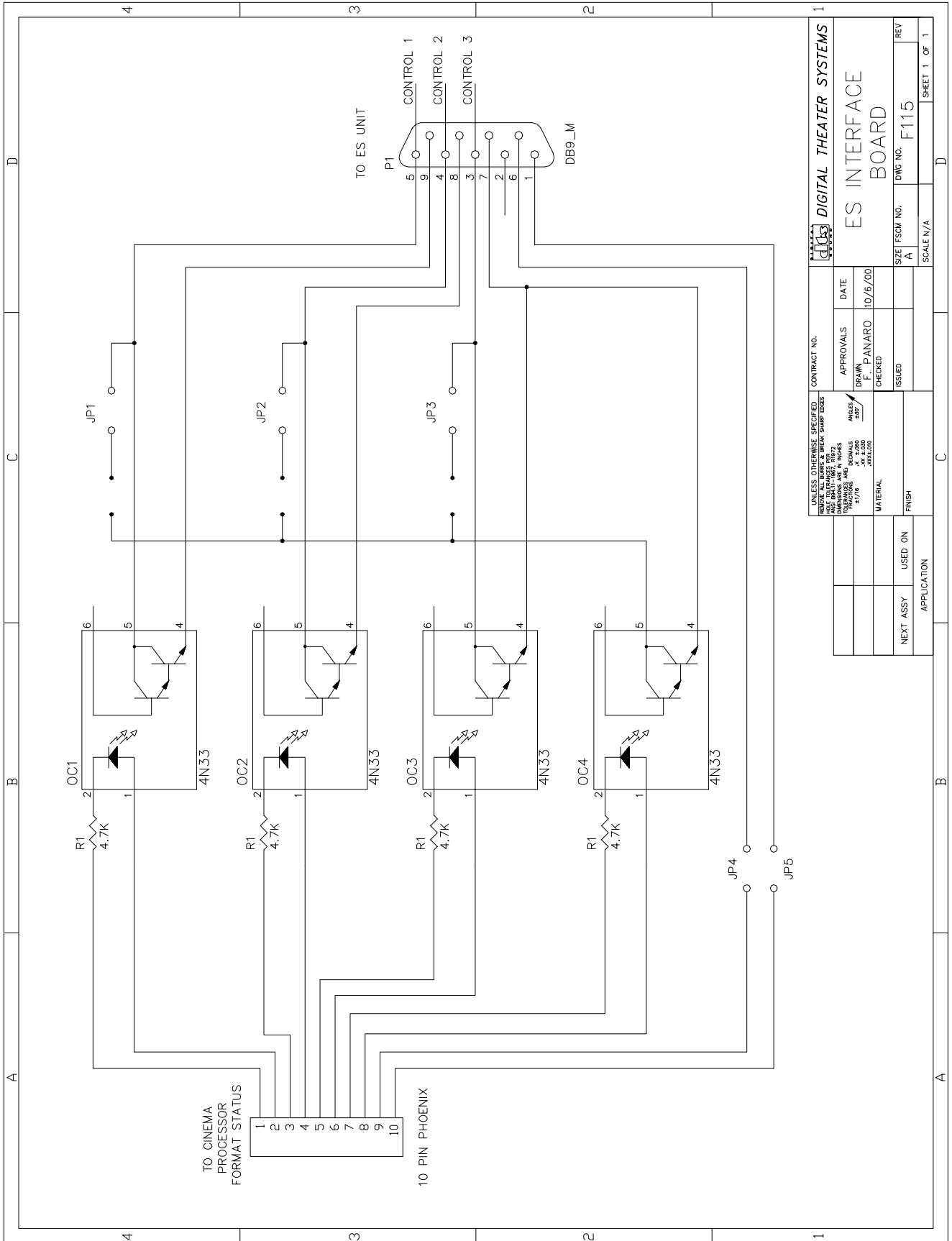

UNLESS OTHERWISE SPECIFIED: REMOVE ALL BURRS & BREAK SHARP EDGES USE 90° BENDS IN WIRING HOLE DIMENSIONS IN INCHES DIMENSIONS IN MILLIMETERS TOLERANCES UNLESS NOTED 1/16" ±0.005 XX ±0.000 ZINC PLATED		CONTRACT NO.	
APPROVALS	DATE	DIGITAL THEATER SYSTEMS	
DRN/	10/6/00	ES INTERFACE BOARD	
F. PANARO		SIZE	FSCM NO.
CHECKED		A	
ISSUED		SCALE	N/A
MATERIAL		DWG NO.	F115
FINISH		REV	
NEXT ASSY	USED ON	SHEET 1 OF 1	
APPLICATION			

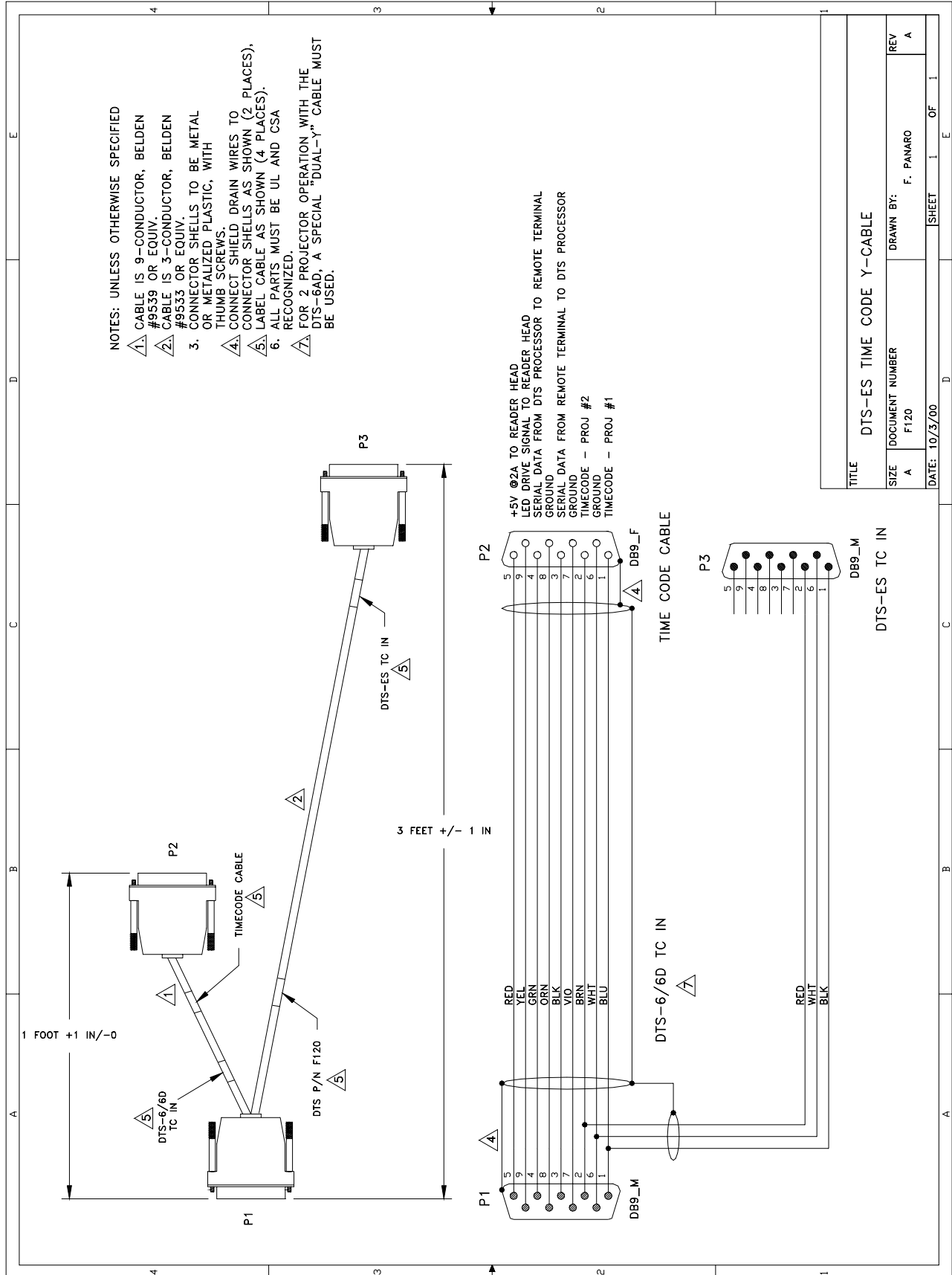

NOTES: UNLESS OTHERWISE SPECIFIED

- 1. CABLE IS 9-CONDUCTOR, BELDEN #9539 OR EQUIV.
- 2. CABLE IS 3-CONDUCTOR, BELDEN #9533 OR EQUIV.
- 3. CONNECTOR SHELLS TO BE METAL OR METALIZED PLASTIC, WITH THUMB SCREWS.
- 4. CONNECT SHIELD DRAIN WIRES TO CONNECTOR SHELLS AS SHOWN (2 PLACES).
- 5. LABEL CABLE AS SHOWN (4 PLACES).
- 6. ALL PARTS MUST BE UL AND CSA RECOGNIZED.
- 7. FOR 2 PROJECTOR OPERATION WITH THE DTS-6AD, A SPECIAL "DUAL-Y" CABLE MUST BE USED.

TITLE		
DTS-ES TIME CODE Y-CABLE		
SIZE	DOCUMENT NUMBER	DRAWN BY:
A	F120	F. PANARO
REV	A	
DATE: 10/5/00	SHEET	OF
1	1	1

REVISIONS

SW	DESCRIPTION	DATE	APPROVED

NOTES: UNLESS OTHERWISE SPECIFIED

1. P1 IS A 15-PIN FEMALE "D" CONNECTOR. USE METALIZED PLASTIC SHELL WITH CAPTIVE THUMB SCREWS.
2. CABLE IS 2-CONDUCTOR SHIELDED, BELDEN #8451 OR EQUIV.
3. STRIP INSULATION OFF WIRE ENDS (SHIELD WIRE EXCLUDED) 1/4" LONG AND TIN.
4. COVER SHIELD DRAIN WITH SHRINK TUBING OR TEFLON SLEEVE (4 PLACES). SHIELD IS NOT CONNECTED AT CONNECTOR (P1) SIDE.
5. LABEL CABLES AS SHOWN.
6. LABEL CABLE "DTS F117" AS SHOWN.
7. ALL PARTS AMUST BE UL, CE RECOGNIZED.

F117

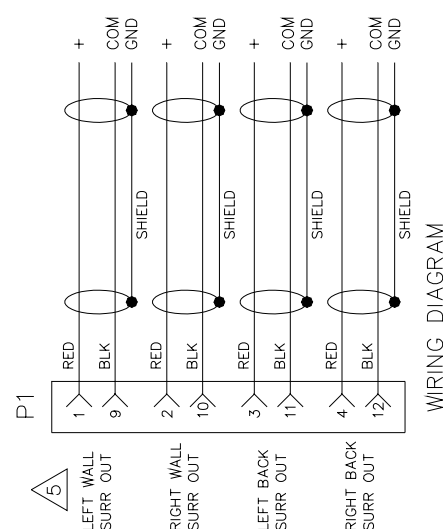
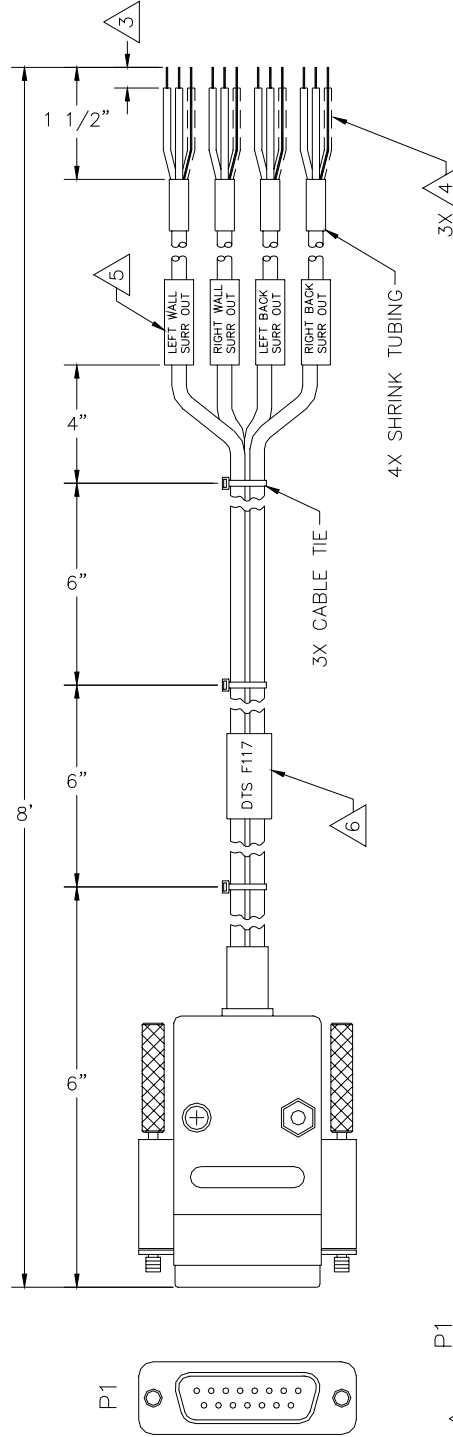

ITEM NO.	PART OR IDENTIFYING NO.	NOMENCLATURE OR DESCRIPTION	VENDOR	QTY	RECD
		DTS	Digital Theater Systems		
		CABLE ASSEMBLY, DTS-ES ANALOG OUT			
		CONTRACT NO.			
		APPROVALS			
		DRAWN	R. T. CRUZ	DATE	4/9/99
		CHECKED			
		ISSUED			
		SIZE	FSCM NO.	DWG NO.	F117
		SCALE	-		
					SHEET 1 OF 1

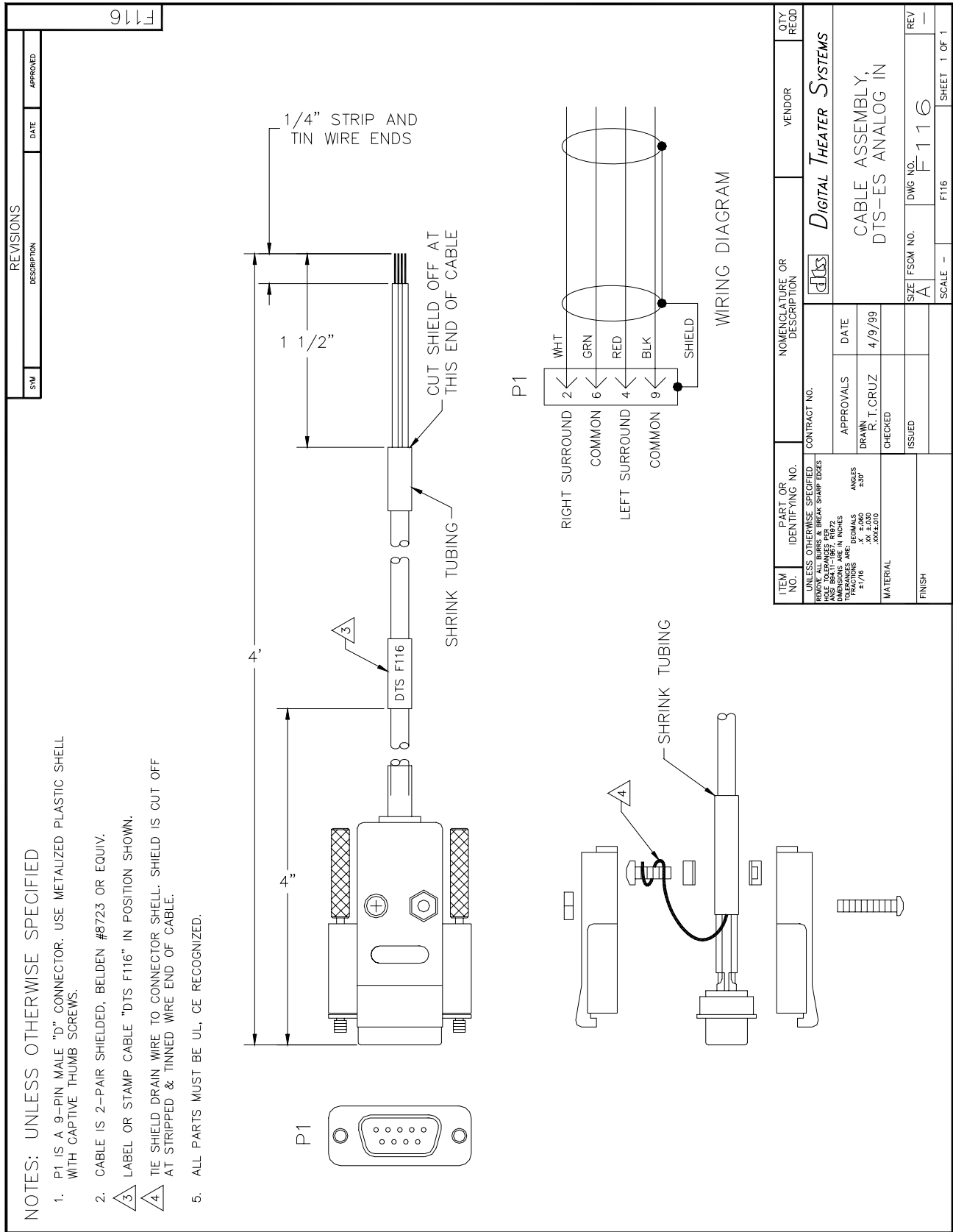

# NOTES

*Thank you for choosing DTS !*

## SECTION 6 TROUBLESHOOTING

### 6.1. INSIDE THE DTS-ES

#### 6.1.1. F109 MAIN CIRCUIT BOARD

This board contains the system firmware and circuitry.

- Jumpers:**
- CT3 and CT4 are seven position headers. Both have one jumper each; buss wire is installed horizontally in 5<sup>th</sup> position (from front, with front panel facing you). Older units used shunts. The shunts should be removed and buss wire should, instead, be installed and soldered in place.
  - LINK2 contacts should be soldered together. Older unit used a shunt. The shunt should be removed and buss wire should, instead, be installed and soldered in place.

**Firmware:** On F109 board:

- System firmware located at IC19
- IC45 firmware, micro-controller
- IC43 firmware, CMOS for IC41
- IC58 firmware, CMOS for IC43

**Contact DTS for latest versions of firmware.**

#### 6.1.2. “FCMB” DISPLAY/SWITCH BOARD

This board contains the display and the five system control switches.

#### 6.1.3. POWER SUPPLY BOARD AND MODULE

This board powers the DTS-ES unit. The power input automatically accommodates AC voltages from 100 VAC to 240 VAC, between 50 & 60 Hz. The power on/off switch is located on the input module (rear panel). An in-line fuse is located on the power supply board. A special insulator prevents the board from making accidental contact with the DTS-ES chassis.

### 6.2. TROUBLESHOOTING GUIDE

#### 6.2.1. DISPLAY ANOMALIES

##### ☒ Blank Display

- Verify power switch (on rear panel) is set to the “on” position (“1” = on, “0” = off).
- Verify F114 cable is connected and locked in place.
- Verify F110 power supply cable to F109 main board is connected and locked in place.
- Check power supply output.
- Try replacing the display.

##### ☒ Menu on display not same as in the manual

- Contact DTS and request DTS-ES system firmware (IC19) upgrade.

##### ☒ Nonsensical Characters on Display

- Cycle power on the DTS-ES unit.
- Contact DTS and request DTS-ES system firmware (IC19) replacement.

##### ☒ Display difficult to read

- Verify F114 cable is connected and locked in place.
- Adjust contrast trim-pot on the display board.
- Replace display.

## 6.2.2. POWER ANOMALIES

## ☒ Unit Seems Dead.

- Verify power cable is connected and DTS-ES unit is receiving AC power.
- Verify power switch (on rear panel) is set to the “on” position (“1” = on, “0” = off).
- Verify F110 power supply cable to F109 main board is connected and locked in place.
- Try replacing the fuse on the power supply board.
- Verify voltage output at CT1 connector on F109 (main board).

Yellow = +5 VDC	Orange = +15 VDC	Red = -15 VDC
Black = Ground	Black = Ground	

- If voltage input OK but has no output, unplug F110 from CT1 connector and measure voltage output.
  - If no output, replace power supply board.
  - If output returns, there is probably a short on the main F109 board. Return unit to DTS for repair.

## 6.2.3. SOUND ANOMALIES

## ☒ Missing surround channel(s)

- Switch DTS-ES to BYPASS (Menu #1) to verify surround channel(s) return.
  - If the channel(s) do not return, the problem is not the DTS-ES unit. Check the cinema processor/amps.
  - If the channel(s) return, verify the setup of the DTS-ES using the ES Setup Disc. If the unit is correctly setup and the surrounds are still incorrect, return the unit to DTS for repair.

## ☒ Cannot adjust surrounds to the correct levels

- Verify the amps are on and correctly set.
- Set the DTS-ES to BYPASS (Menu #1) and verify the cinema processor can adjust the surround levels.
- The DTS-ES surround level(s) should be adjusted no louder than 82dB SPL.

## ☒ Surrounds sound unbalanced

- Verify the amps are on and correctly set.
- Verify the setup of the DTS-ES using the ES Setup Disc.

## ☒ In ES Mode, the sound level too loud/soft as compared to stereo surrounds.

- Verify the setup of the DTS-ES using the ES Setup Disc. Go over the ES Mode setup once again.

## ☒ In ES Mode or Stereo Mode, correct sound-track is playing in surrounds but poor sound quality.

- Verify the setup of the DTS-ES using the ES Setup Disc. Go over the EQ setup once again.
- Verify surround speakers are in good condition.

## ☒ In ES Mode or Stereo Mode, noise is playing in surrounds instead of sound-track.

- Switch DTS-ES to BYPASS (Menu #1).
- Verify LINK2 has been replaced with buss wire. If it has not, the A-to-D converter has probably been damaged and should be replaced. Be aware that the F109 main board uses surface-mount parts and is multi-layered. Over-heating easily damages this type of board. It is therefore highly suggested that a certified DTS service center do the repair. **Traces damaged by over-heating voids the warranty.**

## ☒ Surrounds cut in and out during show.

- Verify unit has software V1.1. This software allows unit to freewheel through small timecode drop-outs.

## 6.2.4. LOGIC ANOMALIES

## ☒ DTS-ES will not automatically switch into ES Mode.

- Verify the film is recorded in DTS-ES: The movie’s serial number, written on the disc, must be 5 digits.
- Verify the setup of the DTS-ES, see Menu #9. If using timecode, be sure “TC” has been enabled. Code A & Code B must be correctly set for the CP used. See Section 4.1, “Menu #9 Auto Enable Programming”.
- Verify the DTS-ES is receiving DTS timecode. Menu #10 displays timecode as received by the DTS-ES.

## ☒ DTS-ES sees timecode from one projector, but not from the second.

- See Section 7, Appendices “Using the DTS-ES with DTS-6AD (or DTS-6/-6D) and Two Projectors”.



## 6.3. REPLACEMENT PARTS LIST

<u>DTS PART #</u>	<u>DESCRIPTION</u>
<b><i>INTERNAL</i></b>	
<b><u>F109 (main) Board</u></b>	
9050F10919	IC19 (system) firmware
1606002200	A-to-D converter (IC15)
1701050400	Relay (RLY1, RLY2, RLY3), 5VDC
<b><u>Power Supply</u></b>	
9022F11000	F110 cable assembly (power supply board to F109 main board)
2201SW0D08	Power supply board
2013000600	Universal AC input module/switcher
2800020003	Fuse, 2 amp slow-blow, 3AG (on power supply board)
9120F11800	Power supply insulator
<b><u>Front Panel</u></b>	
1801002400	“ES STATUS” L.E.D., dual color red/green
9022F11300	F113, L.E.D. cable assembly (from L.E.D. to F109 main board)
9022F11400	F114, cable assembly (from F109 to display/switch board)
9030FCMB00	Display/switch board assembly
1804000301	LCD Display
1905000600	Momentary push-button switch
<b><i>EXTERNAL</i></b>	
2501000100	AC Power Cord, detachable, straight, USA standard
9030F11500	F115, Automation Interface Board
9022F11700	F117, DTS-ES Analog-Out Cable Assembly
9022F11600	F118 DTS-ES Analog-In Cable Assembly
9022F12000	F120, DTS-ES Timecode “Y” Cable Assembly
9022E31200	E312, DTS-ES Two-Projector Cable Adapter
<b>6060001300</b>	<b>DTS-ES (Extended Surround) Test Disc</b>

## 6.4. DTS TECHNICAL SUPPORT

**USA TELEPHONE:** (800) 959-4109 (toll free USA only) *or* (818) 706-3525 **USA FAX:** (818) 706-1868

**UK TELEPHONE:** 44-1189-349199 **FAX:** 44-1189-349198

DTS engineers are available to assist you. If any emergency occurs after business hours, please leave a message with the answering service. Your call will be returned as soon as possible.

**INTERNET** users may email DTS Cinema Technical Support at: [cinematech@dtsonline.com](mailto:cinematech@dtsonline.com)

**DTS web site:** <http://www.dtsonline.com>

# **NOTES**

*Thank you for choosing DTS!*

## **SECTION 7                      APPENDICES**

This chapter contains the following Appendices:

- |            |  |
|------------|--|
| Appendix A | LINK2 ground update                                  |
| Appendix B | Using the DTS-ES with a DTS-6AD and two projectors   |
| Appendix C | Using the DTS-ES with a DTS-6/-6D and two projectors |

## Appendix A: LINK2 Ground Update

On F109 circuit board for the DTS-ES unit, LINK2 connects two grounds together. Originally, this connection was completed by the use of a shunt. Unfortunately, the use of the shunt has proven to be unreliable. If resistance exists between the two grounds, damaged may occur to the A-to-D converter. The shunt has been removed and buss wire now connects the two sides of LINK2 together.

This update effects all DTS-ES units. The update has been completed on all units shipped from DTS as of July 2000.

### Procedure

1. Remove power from the DTS-ES unit.
2. Remove the top cover from the DTS-ES. Be sure to save the screws.
3. Find LINK2 on the main circuit board, F109.
4. Remove the jumper installed on LINK2. Wrap buss wire securely around the two legs and carefully solder in place.

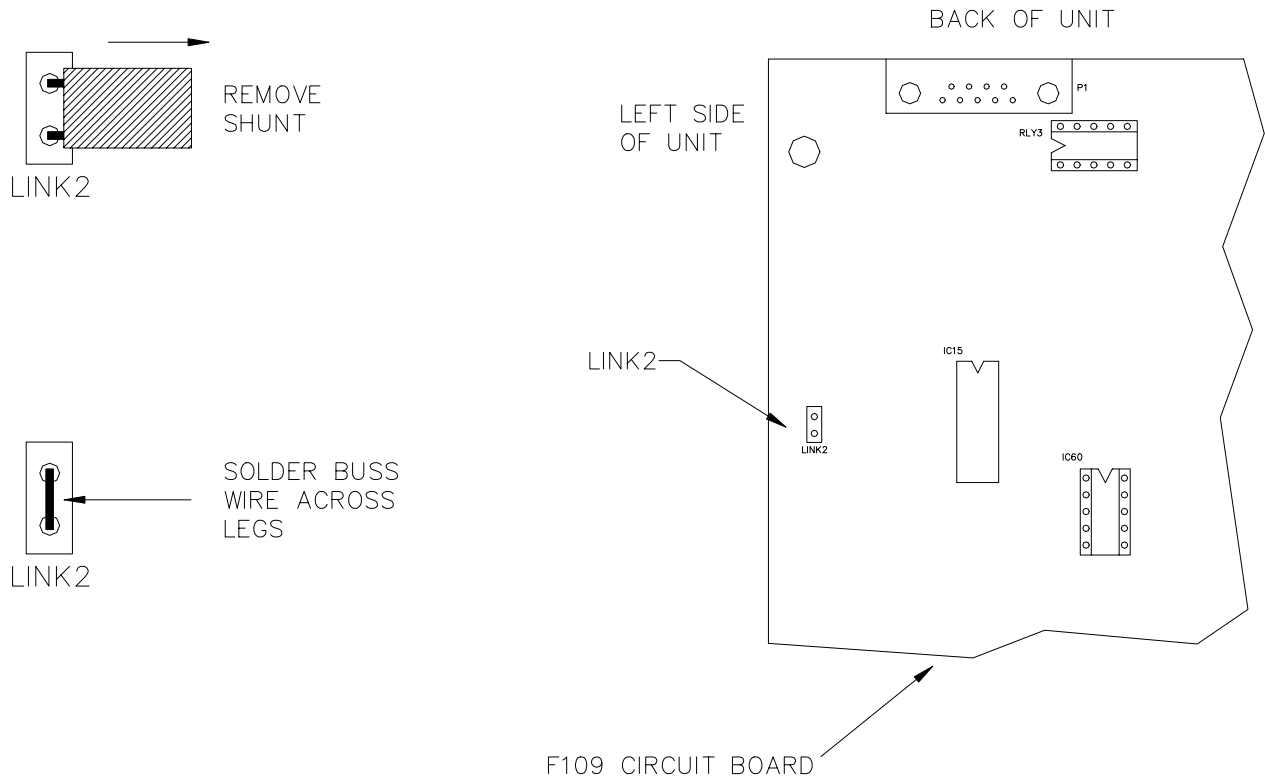

5. Using the saved screws, connect the top cover to the DTS-ES unit.

# Appendix B: Using the DTS-ES with a DTS-6AD and Two Projectors

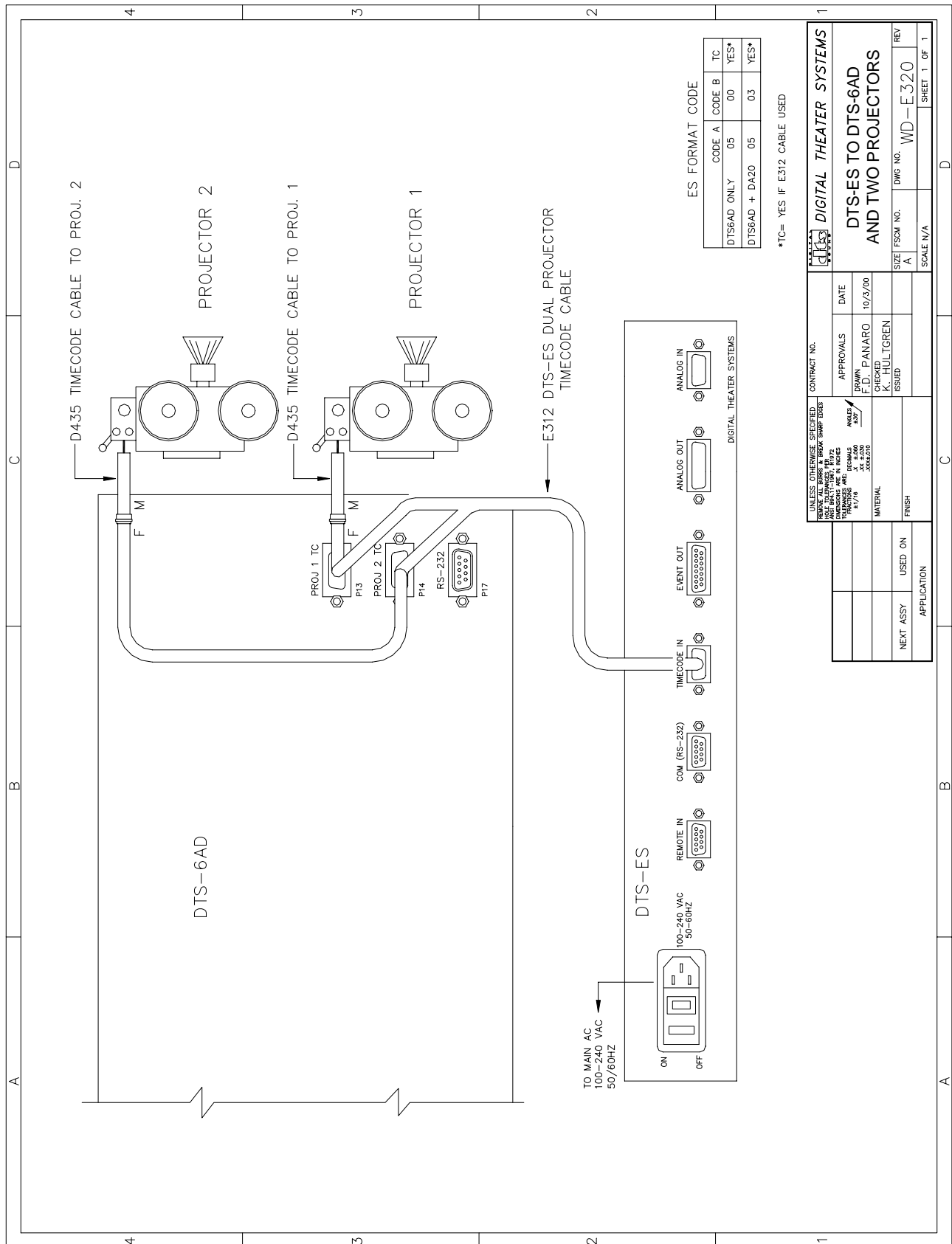

ES FORMAT CODE

CODE A	CODE B	TC	
DTS6AD ONLY	05	00	YES*
DTS6AD + DA20	05	03	YES*

\*TC= YES IF E312 CABLE USED

<b>DIGITAL THEATER SYSTEMS</b>	
<b>DTS-ES TO DTS-6AD AND TWO PROJECTORS</b>	
CONTRACT NO.	DATE
APPROVALS	10/23/00
DRAWN F. D. PANARO	
CHECKED K. HULTGREN	
ISSUED	
MATERIAL	FINISH
NEXT ASSY	USED ON
APPLICATION	
SIZE FSCM NO.	DWG NO.
A	WD-E320
SCALE N/A	SHEET 1 OF 1

# DTS-6AD dual projector adapter cable for DTS-ES

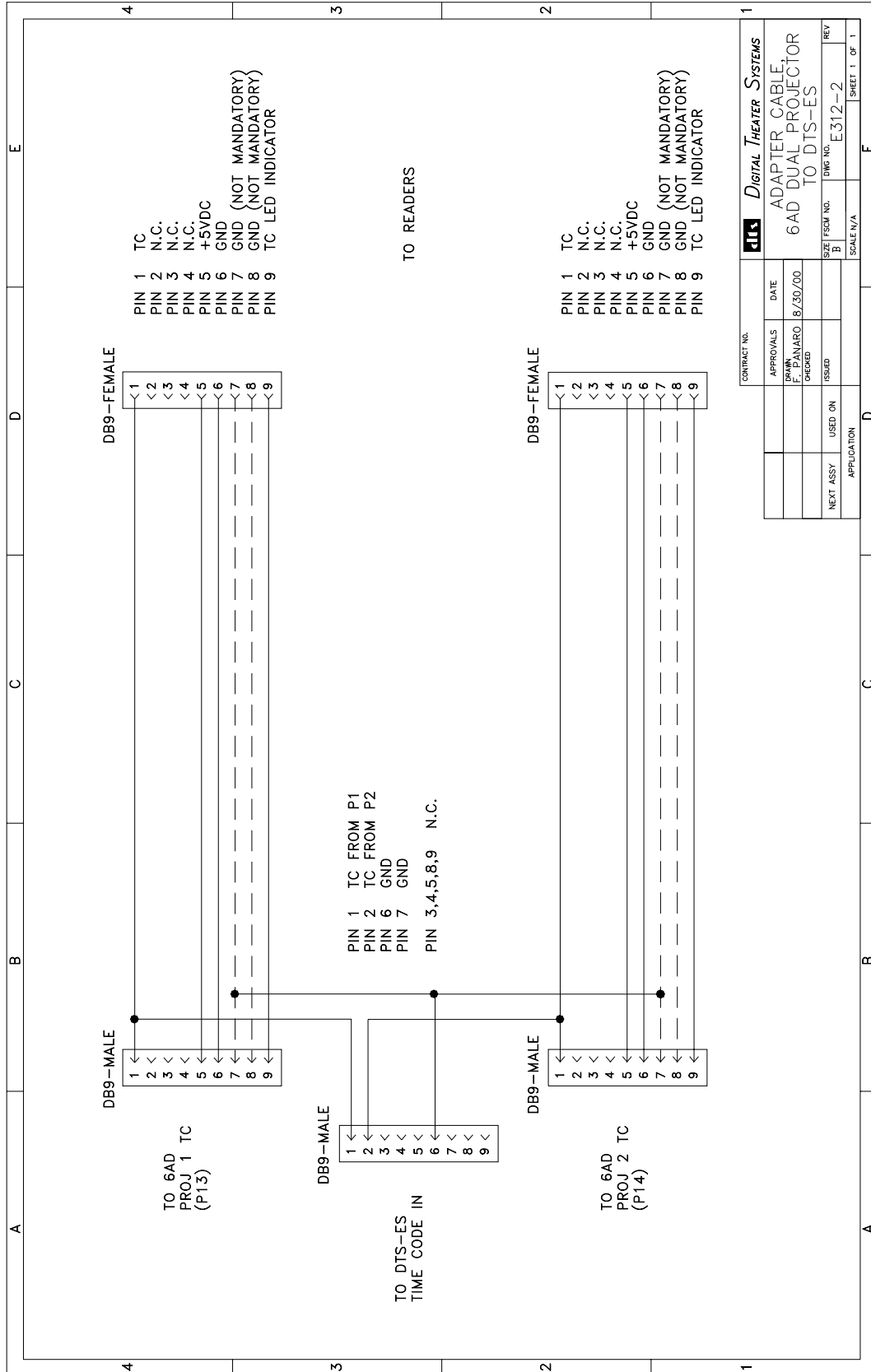

CONTRACT NO.		DTS	
APPROVALS	DATE	DIGITAL THEATER SYSTEMS	
DESIGNED BY	8/30/00	ADAPTER CABLE,	
CHECKED		6AD DUAL PROJECTOR	
ISSUED		TO DTS-ES	
NEXT ASSY	USED ON	SIZE FROM NO.	DWG NO. E312-2
APPLICATION		SCALE	N/A
		SHEET 1 OF 1	

# Appendix C: Using the DTS-ES with a DTS-6/-6D and Two Projectors

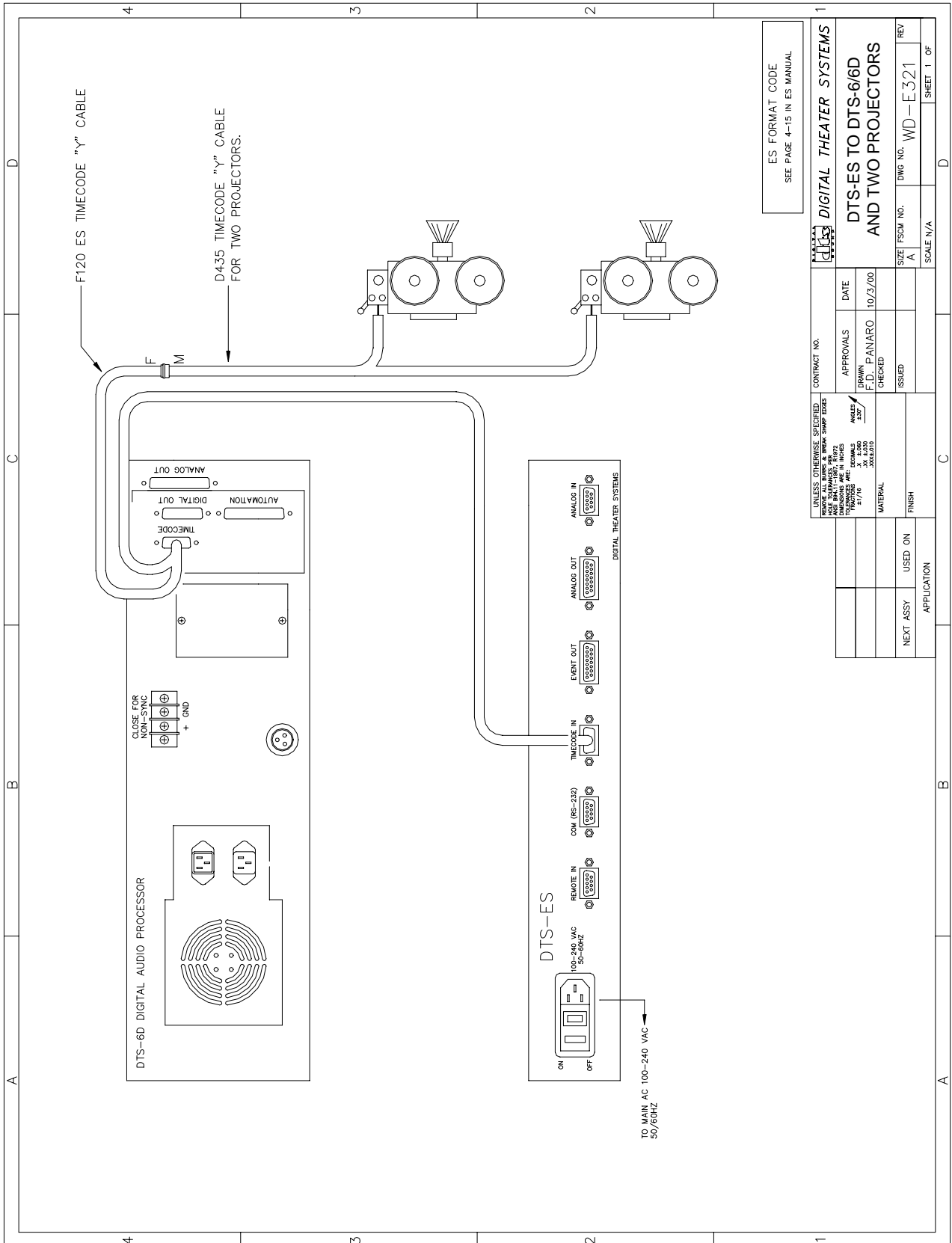

ES FORMAT CODE  
SEE PAGE 4-15 IN ES MANUAL

UNLESS OTHERWISE SPECIFIED  
REMOVE ALL SURGE & BREAK SWAMP LEAKS  
PAGE 100-240 VAC 50-60HZ  
ANALOG IN/OUT  
EVENT OUT  
TIMECODE IN/OUT  
COM (RS-232)  
REMOTE IN  
100-240 VAC 50-60HZ

CONTRACT NO.		DIGITAL THEATER SYSTEMS	
APPROVALS	DATE	DTS-ES TO DTS-6/6D AND TWO PROJECTORS	
DRAWN F.D. PANARO	10/3/00	SIZE	WD-E321
CHECKED		DWG NO.	
ISSUED		SCALE	N/A
MATERIAL		SHEET 1 OF 1	
FINISH			
NEXT ASSY	USED ON		
APPLICATION			

# **NOTES**

*Thank you for choosing DTS !*



**Appendix D: Connecting DTS-ES to Dolby CP650** (without the Cat. 794 board installed)

1. Rewire CP650 to surround amplifiers as shown in “DTS-ES to CP650” wiring diagram, next page.
2. If using DTS timecode “Y” cable, set DTS-ES “TC” to “Yes” (Menu #9). Codes A & B not used.
3. If not using DTS timecode “Y” cable, connect the DTS F115 automation interface board as shown in “DTS-ES to CP650” wiring diagram, next page.
  - Set “TC” to “No”. Codes A & B must be set so the DTS-ES can monitor the digital format automation LED lines.
  - **Code A** is used to monitor the DTS Digital line (CP650 “Automation I/O connector”, pin 5). When it goes low, the DTS-ES unit should automatically start ES decoding. Typically, this point is assigned to control Format 11, which is the “External 6-channel Analog Input” connector and where the DTS-6/-6D player should be connected.
  - **Code B** is used to monitor the Dolby Digital™ line (CP650 “Automation I/O connector”, pin 4). When it goes low, the DTS-ES unit should automatically start ES decoding. Typically, this point is assigned to control Format 10.
  - Set DTS-ES “ANALOG OUTPUT MODE” to “NORMAL” (Menu #1) for operation.
4. Set levels and adjust surround EQ as detailed in Section 4.3.

**NOTES:**

▲ IF REMOTE FADER IS CONNECTED, USE E322 EXTENDER.

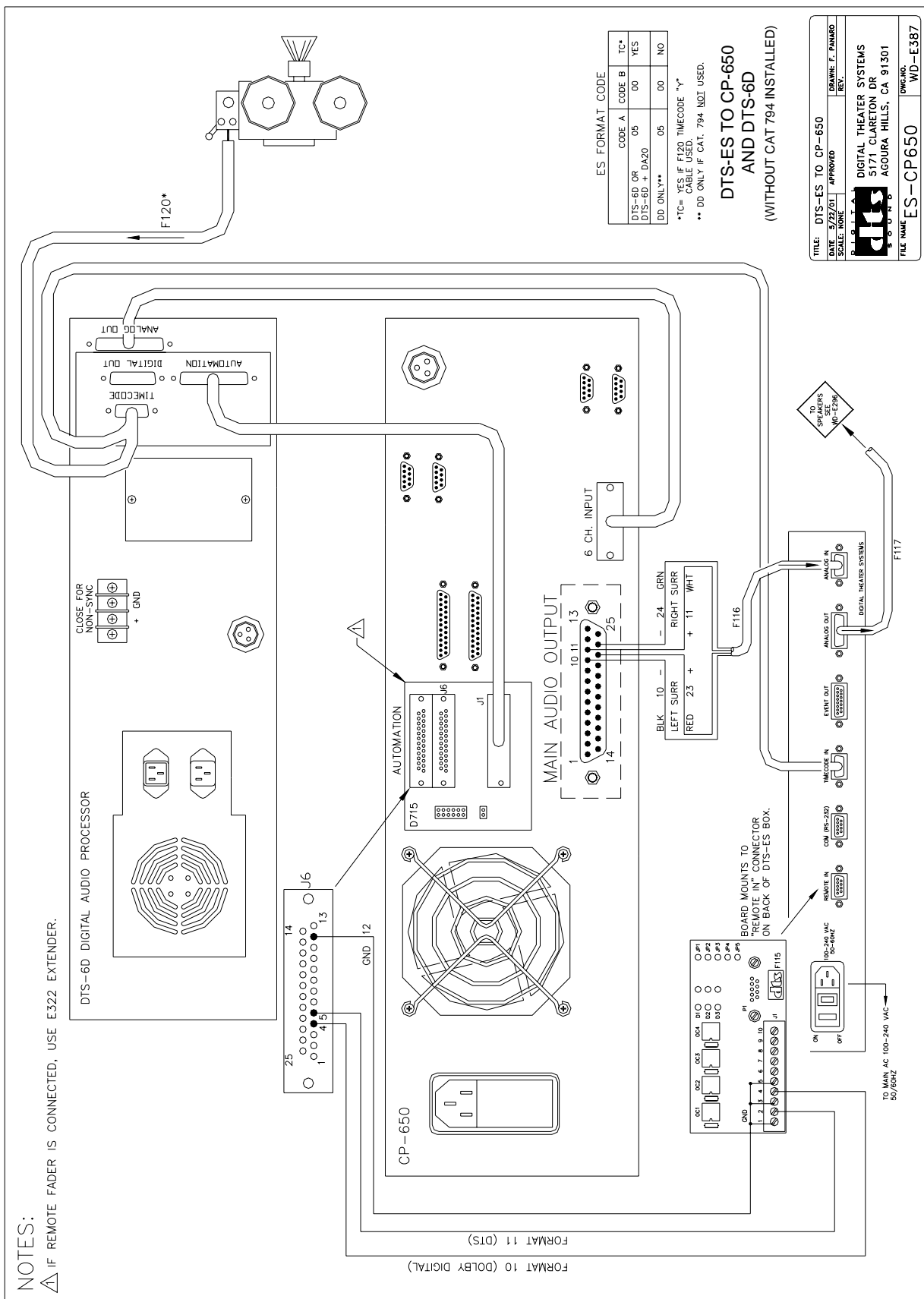

ES FORMAT CODE

	CODE A	CODE B	TC*
DTS-6D OR	05	00	YES
DTS-6D + DA20			
DD ONLY**	05	00	NO

\*TC = YES IF F120 TIMECODE "Y"  
 \*\* DD ONLY IF CAT. 794 NOT USED.

**DTS-ES TO CP-650 AND DTS-6D (WITHOUT CAT 794 INSTALLED)**

TITLE: DTS-ES TO CP-650		DRAWN: F. PANARO
DATE: 5/22/01	APPROVED:	REV.
DIGITAL THEATER SYSTEMS 5171 CLARETON DR AGOURA HILLS, CA 91301		
FILE NAME: ES-CP650	DWG. NO.:	WD-E387

FORMAT 10 (DOLBY DIGITAL)  
 FORMAT 11 (DTS)