

# Film-Tech

The information contained in this Adobe Acrobat pdf file is provided at your own risk and good judgment.

These manuals are designed to facilitate the exchange of information related to cinema projection and film handling, with no warranties nor obligations from the authors, for qualified field service engineers.

If you are not a qualified technician, please make no adjustments to anything you may read about in these Adobe manual downloads

[www.film-tech.com](http://www.film-tech.com)



# CM16 MultiSignal Processor

HARDWARE  
MANUAL



▼ CM16

Rev. B

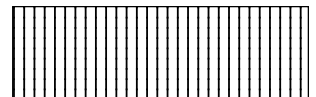

# Table of Contents

---

## CM16 MultiSignal Processor User Manual

<b>I. INTRODUCTION .....</b>	<b>3</b>
Physical characteristics .....	3
Functional description .....	5
Network description .....	6
<b>II. INSTALLATION .....</b>	<b>10</b>
Location considerations .....	10
Mounting the CM16 MultiSignal Processor .....	10
Connecting to AC power .....	11
Connecting to amplifiers .....	11
Connecting audio and logic cabling .....	11
Program inputs .....	11
Page .....	11
Monitor chain .....	12
Contact closures .....	12
Isolated contact outputs .....	12
<b>III. SPECIFICATIONS .....</b>	<b>13</b>
<b>IV. ARCHITECT'S AND ENGINEER'S SPECIFICATIONS .....</b>	<b>16</b>
<b>V. APPENDIX: Ethernet cabling; Data port pinout .....</b>	<b>17</b>
<b>VI. QSC ADDRESS AND TELEPHONE INFORMATION .....</b>	<b>18</b>

## EXPLANATION OF GRAPHICAL SYMBOLS



The lightning flash with arrowhead symbol, within an equilateral triangle, is intended to alert the user to the presence of uninsulated "dangerous voltage" within the product's enclosure that may be of sufficient magnitude to constitute a risk of electric shock to humans.



The exclamation point within an equilateral triangle is intended to alert the users to the presence of important operating and maintenance (servicing) instructions in the literature accompanying the product.

## EXPLICATION DES SYMBOLES GRAPHIQUES



Le symbole éclair avec point de flèche à l'intérieur d'un triangle équilatéral est utilisé pour alerter l'utilisateur de la présence à l'intérieur du coffret de "voltage dangereux" non isolé d'ampleur suffisante pour constituer un risque d'électrocution.



Le point d'exclamation à l'intérieur d'un triangle équilatéral est employé pour alerter les utilisateurs de la présence d'instructions importantes pour le fonctionnement et l'entretien (service) dans le livret d'instruction accompagnant l'appareil.

## ERKLÄRUNG DER GRAPHISCHEN SYMBOLE



Der Blitz nach unten zeigendem Pfeil in einem gleichseitigen Dreieck weist den Benutzer auf das Vorhandensein einer unisolierten, „gefährlichen Spannung“ im Gehäuse hin, die stark sein kann, einer Person einen elektrischen Schlag zu versetzen.



Das Ausrufzeichen in einem gleichseitigen Dreieck weist den Benutzer auf wichtige Betriebs- und Wartungsvorschriften in den beiliegenden Unterlagen des Gerätes hin.



**CAUTION:** To reduce the risk of electric shock, do not remove the cover. No user-serviceable parts inside. Refer servicing to qualified service personnel.

**WARNING:** To prevent fire or electric shock, do not expose this equipment to rain or moisture.



**ATTENTION:** Pour éviter les risques de choc électrique, ne pas enlever le couvercle. Aucun entretien de pièces intérieures par l'utilisateur. Confier l'entretien au personnel qualifié.

**AVIS:** Pour éviter les risques d'incendie ou d'électrocution, n'exposez pas cet article à la pluie ou à l'humidité.



**VORSICHT:** Um das Risiko eines elektrischen Schlags zu vermindern, Abdeckung nicht entfernen! Keine Benutzer Wartungsteile im Innern. Wartung nur durch qualifiziertes Wartungspersonal.

**WARNUNG:** Zur Vermeidung von Feuer oder elektrischen Schlägen, das Gerät nicht mit Regen oder Feuchtigkeit in Berührung bringen!

### SAFEGUARDS

Electrical energy can perform many useful functions. This unit has been engineered and manufactured to assure your personal safety. Improper use can result in potential electrical shock or fire hazards. In order not to defeat the safeguards, observe the following instructions for its installation, use and servicing.

### PRECAUTIONS

L'énergie électrique peut remplir de nombreuses fonctions utiles. Cet appareil a été conçu et réalisé pour assurer une sécurité personnelle entière. Une utilisation impropre peut entraîner des risques d'électrocution ou d'incendie. Dans le but de ne pas rendre inutiles les mesures de sécurité, bien observer les instructions suivantes pour l'installation, l'utilisation et l'entretien de l'appareil.

## FEDERAL COMMUNICATIONS COMMISSION (FCC) INFORMATION

NOTE: This equipment has been tested and found to comply with the limits for a Class A digital device, pursuant to Part 15 of the FCC Rules. These limits are designed to provide reasonable protection against harmful interference in a commercial installation. This equipment generates, uses, and can radiate radio frequency energy and, if not installed and used in accordance with the instructions, may cause harmful interference to radio communications. Operation of this equipment in a residential area is likely to cause harmful interference, in which case the user will be required to correct the interference at his or her own expense.

# I. INTRODUCTION

---

The QSC CM16 MultiSignal Processor offers powerful amplifier management in a QSControl2 networked audio system, using Ethernet networking technology to communicate with the host computer/system controller.

The system controller computer itself uses application software to operate the networked audio system, including the CM16s and their amplifiers. The software operates on the Windows 95 operating system and can be customized using Microsoft Visual Basic Professional Edition®. See the software manual or help file for more information on software usage and functions.

The CM16 MultiSignal Processor performs control and monitoring functions for up to eight dual-channel amplifiers, each equipped with a Data Port—either built-in or on a DP1 Data Port Module. QSC PowerLight Series amplifiers (except for early models not equipped with data ports) have built-in Data Ports for this purpose, while CX, EX, and MXa Series amplifiers require a DP1 accessory (available from QSC or an authorized QSC dealer) installed in the Open Input Architecture slot. PowerLight amplifiers have full control and monitoring functionality, while the number of control and monitoring functions available through the DP1 depends on the amplifier series used. MXa and CX Series amplifiers have somewhat fewer available control and monitoring functions than the EX Series; for more information consult the documentation included with the DP1.

The Data Port uses an HD15 connector, which is the same type that standard VGA computer monitors and video cards use. This allows you to use a standard VGA cable for interconnecting an amplifier and a CM16 unit.

A CM16 unit controls and monitors as many as eight amplifiers; they are designated in this manual and on the rear panel of the unit as Amp A through Amp H. A network may have multiple CM16's, providing remote management for systems ranging from a few up to hundreds of amplifiers.

## PHYSICAL CHARACTERISTICS

Each CM16 unit is two rack spaces in height and has an internal AC power supply. Its chassis depth is 41.9 cm, or 16.5 inches, plus 1-inch (2.54 cm) rear support tabs.

The rear panel has a female RJ-45 jack for connecting to an Ethernet using 10BASE-T wiring. An AUI interface allows you to use an appropriate transceiver for 10BASE-F (fiber optic), 10BASE-5 (thick coaxial cable, also called ThickNet), 10BASE-2 (thin coaxial cable, such as RG-58 or equivalent, also known as Thin Ethernet, ThinNet, or CheaperNet), or other Ethernet media. The raw data rate is 10 Mbps.

Figure 1 shows the front panel of a CM16 unit, including the AC power switch and several LED indicators:

**Figure 1**  
*CM16 MultiSignal Processor front panel*

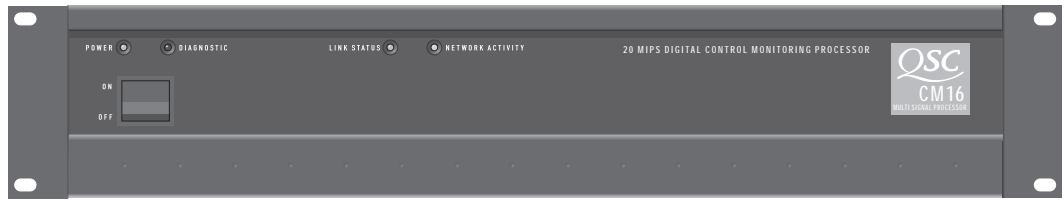
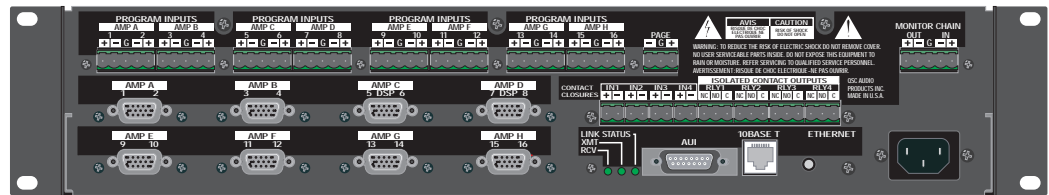

Figure 2 shows the rear panel of a CM16 unit and its features:

**Figure 2**  
*CM16 MultiSignal Processor rear panel*



Eight HD-15 connectors for connecting to data ports of amplifiers A through H

One RJ-45 jack for connecting to a 10BASE-T Ethernet computer network

One AU1 connector for connecting a transceiver to use with other Ethernet media

One IEC connector for a detachable AC power cord (included)

Four contact closure inputs for remote sensing

Four SPDT relay contact outputs for remote switching

Three LED indicators to show network communication status

“Euro-style” detachable terminal strips for line-level audio inputs, monitor chain input and output, contact closure logic inputs, and relay contact outputs

### **AC power**

Each CM16 device is factory-configured to operate on 100, 120, or 230 volts, 50 or 60 Hz; a label on the bottom of the unit shows the correct operating voltage. Make sure you connect the CM16 unit only to the correct voltage; otherwise, you might damage it and also create a dangerous situation for yourself and others. The detachable power cord attaches to the CM16 unit via the IEC connector on the rear panel. A front panel LED, located above the power switch, indicates when the CM16 is powered up.

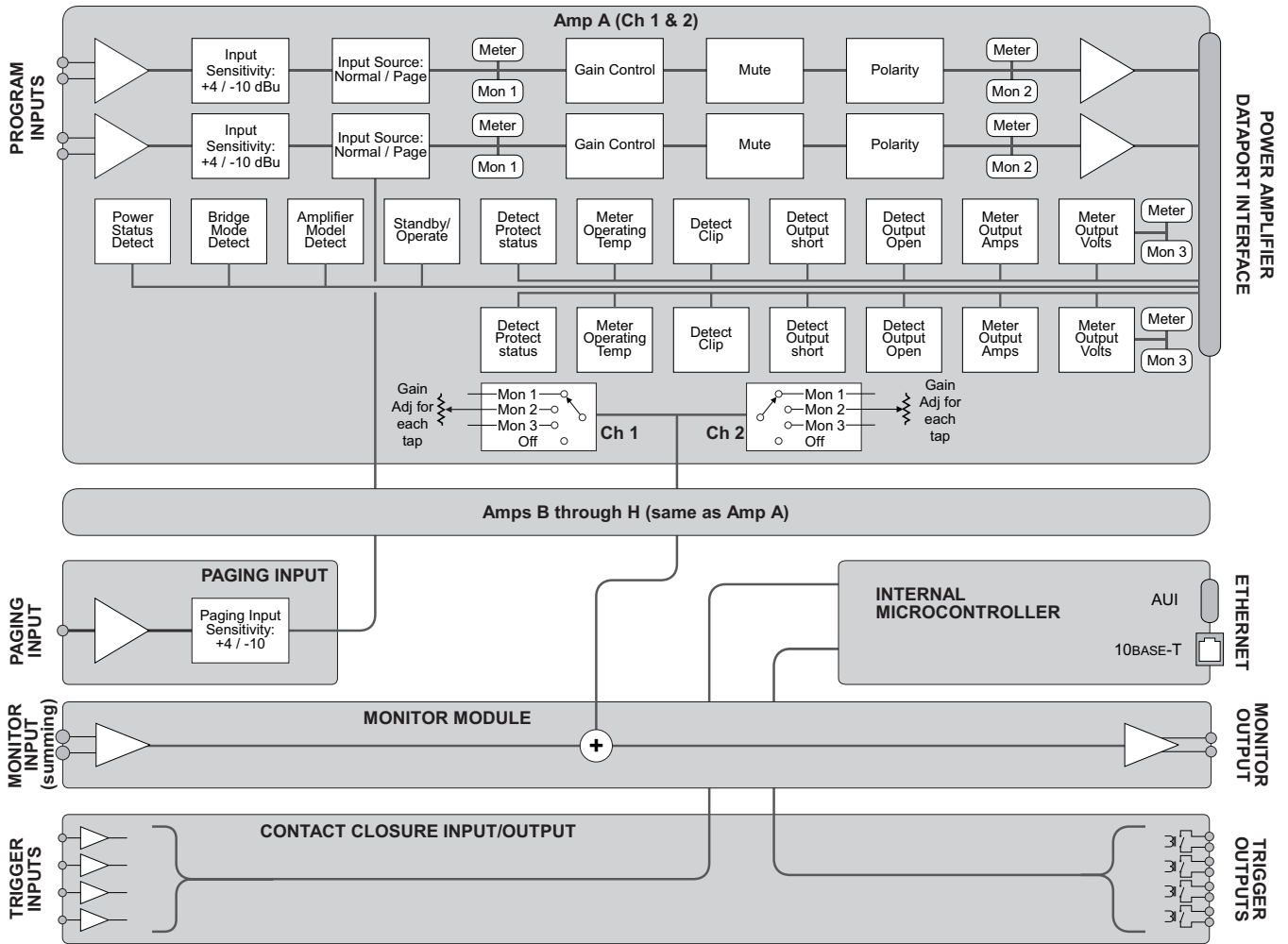

Functional block diagram of the CM16 MultiSignal Processor

## FUNCTIONAL DESCRIPTION

The CM16 performs control and monitoring functions remotely between the amplifiers and the host computer.

This matrix indicates which control functions are available for various models of QSC amplifiers.

	PowerLight Series	EX Series (with DP-1 card)	MXa Series (with DP-1 card)	CX, CXi Series* (with DP-1 card)
Channel signal gain	•	•	•	•
Channel signal mute	•	•	•	•
Channel signal polarity	•	•	•	•
Channel input sensitivity select (+4 dBu or -10 dBV)	•	•	•	•
Remote power on/standby	•	†	†	†
Paging or normal input select	•	•	•	•

\*Except CX4 and CX4T  
†Units with RPC only

Note that the PowerLight models are the only ones with built-in remote turn-on/turn-off capability; certain other models require the installation of an appropriate RPC remote power control card. Contact the QSC Technical Services department for information on what amplifier models can receive this upgrade.

This matrix indicates which monitoring functions are available for various QSC amplifier models.

	PowerLight Series	EX Series (with DP-1 card)	MXa Series (with DP-1 card)	CX, CXt Series* (with DP-1 card)
CM16 input gain metering (pre-fader)	•	•	•	•
CM16 output/amp input gain metering (post-fader)	•	•	•	•
Power status detect	•	•	•	•
Bridge mode detect	•	•	•	•
Amplifier model detect	•	•	•	•
Protect status detect	•	•	†	•
Heat sink temperature metering	•	•	•	•
Clip detect	•	•	†	•
Output short detect	•			
Output open detect	•			
Amplifier channel output metering (voltage and current)	•	V only	V only	V only
Source-selectable signal monitor	•	•	•	•

\*Except CX4 and CX4T  
†Except MX3000a

There are also four discrete floating relay contact closure outputs for remotely switching external devices, up to 250 mA (500 mA steady-state) per contact pair. Four discrete single-ended logic inputs allow for sensing external events or switches; these inputs have internal sense voltage sources, so they are compatible with both logic devices and switches.

## NETWORK DESCRIPTION

QSC CM16 MultiSignal Processors are designed to operate on a standard IEEE 802.3 Ethernet, and each one operates as a respective node on its network. Each unit contains a unique Ethernet hardware address in non-volatile memory, and will therefore present no conflict with any other node on the same network. You can even use CM16 devices on a network shared with other networked devices, such as servers, workstations, and other computers, although these other devices may affect network performance if their rate of network utilization is very high. Ethernet devices such as hubs, repeaters, and routers will usually afford you the flexibility to configure the network as needed.

Any system controller computer on the network must have an Ethernet-compatible network interface card (NIC) installed. To allow you to operate the network even during power interruptions, it might be a good idea to use an uninterruptible power supply (UPS) with the host computer(s) and any hubs or repeaters.

A female RJ-45 connector on the rear panel allows a direct connection to a 10BASE-T network. Use Category 3 or better unshielded twisted pair (UTP) Ethernet cable. (Most ready-made Ethernet patch

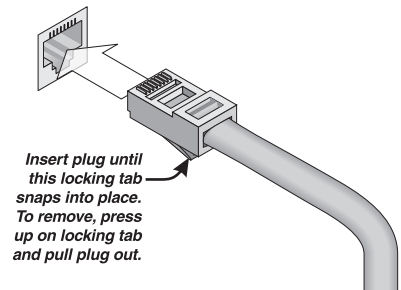

Connecting to Ethernet



cables available today are rated at least Category 5, so they would be perfectly suitable for the application.) For use with other Ethernet medium, such as 10BASE-2, 10BASE-5, 100BASE-T, 100BASE-F, etc., the rear panel also has an attachment unit interface (AUI) connector, to which you would attach a suitable transceiver.

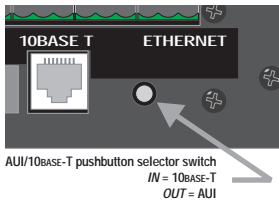

### Selecting AUI or 10BASE-T network connections

A pushbutton switch next to the RJ-45 connector allows you to switch the network connection between the 10BASE-T Ethernet connection—provided by the RJ-45 connector—and a transceiver connected to the AUI connector. If the switch is in the *in* position, the RJ-45 connection is active; if the switch is *out*, the AUI is.

### Network status and diagnostic LED indicators

For diagnostic purposes, there are LED indicators on both the front and rear panels of the CM16.

The ones on the rear are located next to the multi-pin AUI connector and are labeled **LINK STATUS**, **XMT**, and **RCV**.

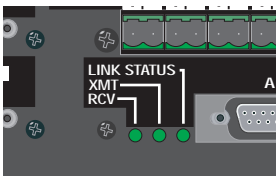

**LINK STATUS**—When lit, this LED indicates that the CM16 is connected to an operating Ethernet network. If it is unlit, there is probably some problem in the network cabling between the CM16 and the hub, or possibly a fault in the hub. This LED only indicates a link via the RJ-45 connector, not via an AUI (most AUI transceivers have their own LED indicators for status, transmit, and receive).

**XMT**—This LED lights to indicate that the CM16 is transmitting data over the network.

**RCV**—This LED lights up whenever the CM16 receives data from over the network.

The status LEDs on the front panel are labeled **DIAGNOSTIC**, **LINK STATUS**, and **NETWORK ACTIVITY**. The



**POWER** LED is also on the front panel, although it really isn't a network status indicator; nevertheless, if it isn't lit, the CM16 is either turned off or disconnected from the AC source, so you wouldn't see any network activity anyway.

**DIAGNOSTIC**—This LED performs several functions. When the CM16 is powered up, the LED flashes to indicate that the unit is first performing a self-diagnostic test and then loading the current settings the onboard flash memory. This takes several seconds, and if the LED stays on longer than that, it indicates an internal hardware fault.

During operation, the CM16 continually performs a reduced set of self-diagnostic functions, including a background memory check. If it detects a memory fault, the LED will flash at a rate of about 2 Hz; if some other hardware fault is found, the LED will light continuously.

Also during operation, the operator can turn the LED on and off using a custom Visual Basic application on the network's system controller computer. This is useful for identifying individual CM16s on the network.

**LINK STATUS**—This LED has the same function as the one on the rear panel, which is described above. This LED only indicates a link via the RJ-45 connector, not via an AUI.

**NETWORK ACTIVITY**—This LED combines the functions of the rear-panel **XMT** and **RCV** LEDs, i.e., it lights whenever the CM16 is transmitting or receiving data. If you want to think of it as a Boolean expression, then **NETWORK ACTIVITY** = **XMT or RCV**.

**Sample network topologies**

The simplest network configuration would be a single system controller computer and a CM16, with a single network cable connecting them. In this situation, a normal Ethernet cable would not work; instead, you would need an Ethernet *crossover* cable, which is somewhat analogous to a null-modem cable. The maximum cable length is 100 meters, or 330 feet.

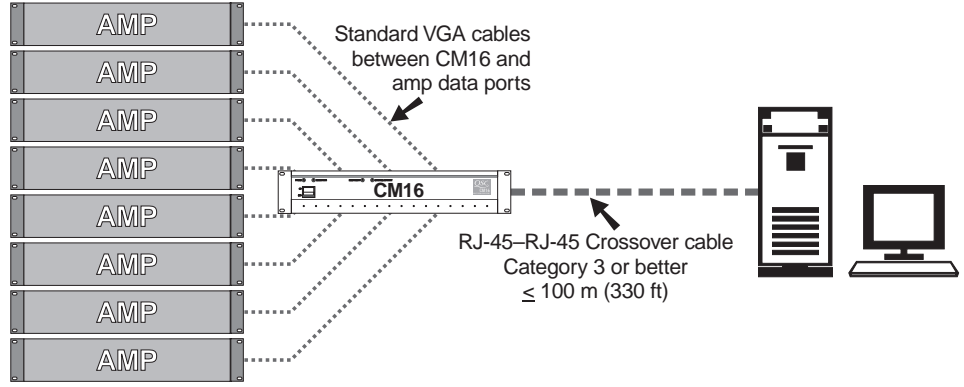

For distances longer than 100 meters, you need a repeater and standard category 3 or better UTP Ethernet cables. Instead of a repeater, you can also use an active hub—one which “cleans up” and re-transmits the network traffic as a repeater does, only with multiple ports—to allow for future expansion.

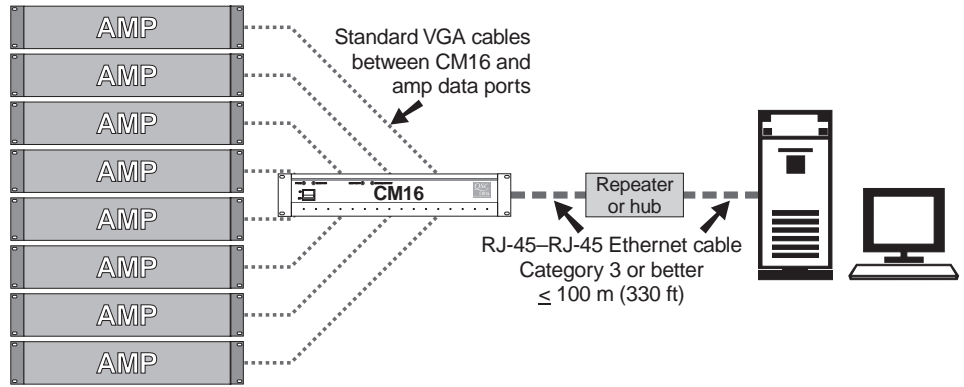

If there are two or more CM16s in the network, or there are other networked devices present, use a hub to create a star topology.

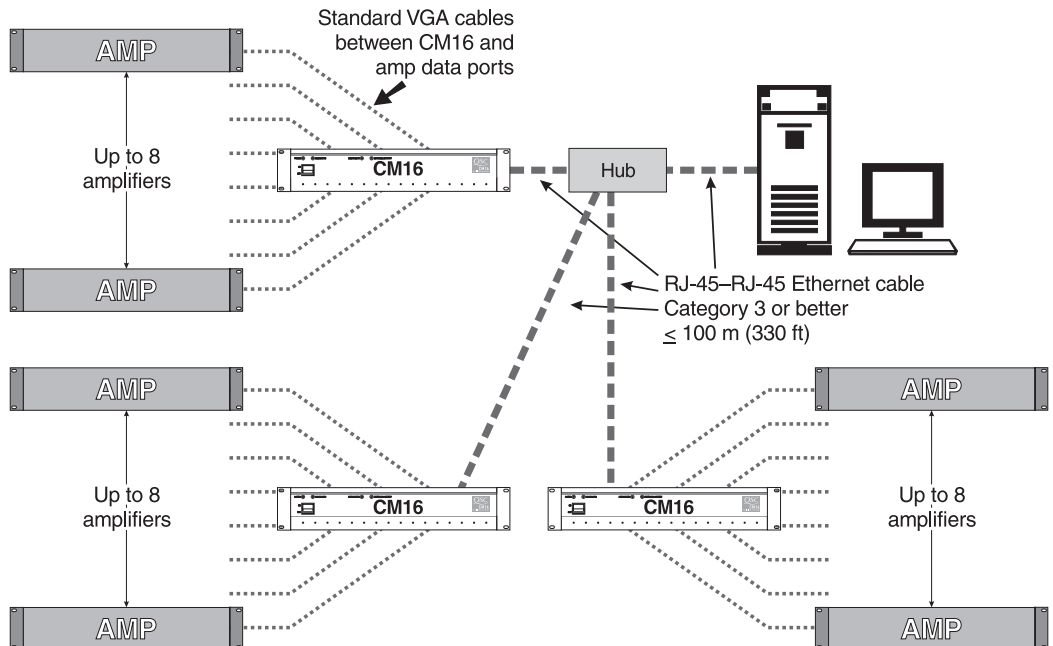

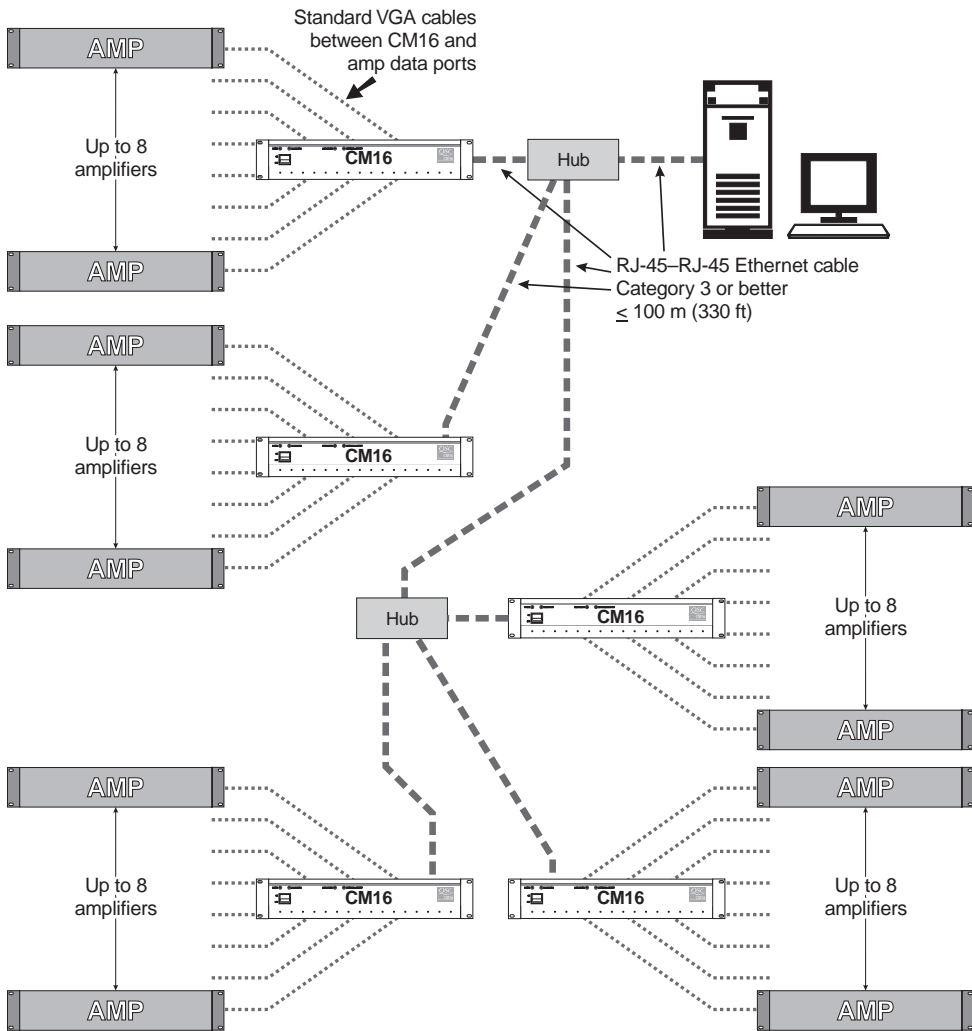

To create the more complex distributed star topologies necessary for larger systems, use additional hubs. Some hubs have special uplink ports for connecting to other hubs via a standard Ethernet cable; if the hubs don't have an uplink port, use an Ethernet crossover cable to link the hubs via their normal ports.

# II. INSTALLATION

## LOCATION CONSIDERATIONS

The physical limitations of the Ethernet, the placement of the amplifiers, and the locations of the system operators are the guiding points in determining where the CM16 devices and host computers should be installed. In turn, their placement will determine the specific routing of the Ethernet cabling.

The system controller computer, naturally, should be located someplace convenient for the system operator. Physically, each CM16 device must be located near the amplifiers to which it is connected. Typically, they would be in the same or adjacent equipment racks. The connection between CM16 and amplifier is via a readily available standard 15-conductor shielded VGA cable, which carries control and monitoring data to and from the amplifier, and also carries two channels of audio signals to the amplifier. Standard, off-the-shelf VGA cables are typically two to three meters long (about 6 to 10 feet).

The maximum length of any 10BASE-T Ethernet network segment—that is, the cabling between any node and the next node, hub, or repeater—is 100 meters, or 328 feet, so you will need to place the hubs and/or repeaters accordingly. If that is impractical because of very long distances, use appropriate AUI transceivers and fiber optic cabling; this offers the possibility of segments up to 5 kilometers (approximately 16400 feet, or 3.1 miles) long for 10BASE-F networking. The AUI connector is located on the rear panel, next to the RJ-45 jack. For larger networks, you might need to use Ethernet routers.

## MOUNTING THE CM16 MULTISIGNAL PROCESSOR

Use four screws to secure the front of the CM16 to the equipment rack. For mobile, touring, or portable applications, provide a rear support also; QSC's Technical Services department stocks kits for installing rear mounting ears.

The CM16 uses fan-drawn air for cooling. Its intake is on one side panel of the chassis, and the exhaust slots are on the other side. *Be*

*careful not to obstruct*

*these openings, and allow ample open space around them, in order to maintain a free flow of air.*

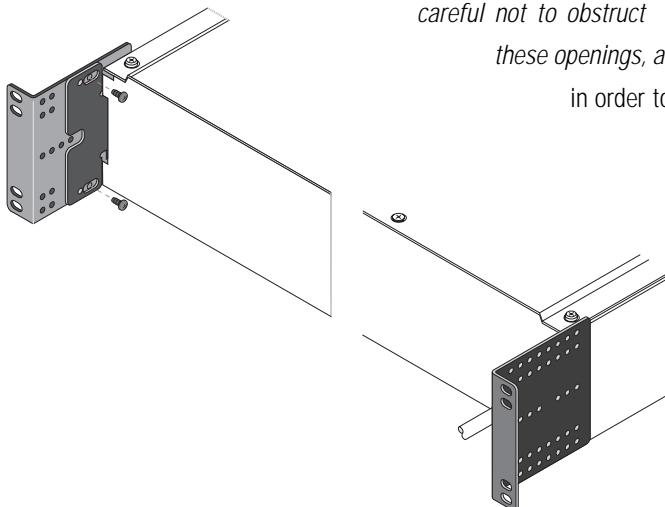
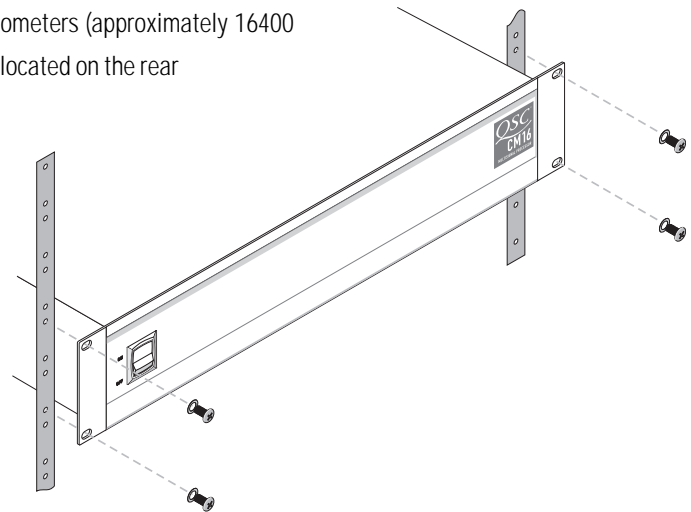

**NOTE:** The CM16's recommended ambient operating temperature is 0°–50° C (32°–122° F). Do not install the unit in an environment that exposes it to temperatures outside this range.



## CONNECTING AC POWER

The CM16 uses a detachable power cord for connecting to a grounded AC source. Each unit is configured at the factory to use a particular line voltage (100, 120, or 220–240 volts AC); that voltage is printed on the serial number label affixed to the underside of the CM16 chassis. Make sure the power cord is suitable for the unit's operating voltage; connecting the CM16 to the wrong voltage is dangerous and may damage the unit.

A CM16 can be reconfigured to work with a different line voltage. Consult the QSC Technical Services department for more information.

## CONNECTING TO AMPLIFIERS

Use standard, off-the-shelf VGA cables to connect between the amplifiers' data ports and their respective HD-15 ports on the rear panel of the CM16 unit. The amplifier ports are labeled A through H on the CM16 rear panel. All necessary data and audio signals to and from the amplifier pass through the VGA cable.

The CM16 automatically identifies the amplifier models attached to its ports. It provides this information over the network to the QSCControl2 software in the system controller computer, which can indicate on-screen the models of amps A through H attached to each particular CM16 device. The CM16 and the software also use the model identification information to set appropriate ranges for the amplifier output voltage and current metering.

## CONNECTING AUDIO AND LOGIC CABLING

The terminal block portions of the barrier strip inputs and outputs detach for ease of service; it also allows you to pre-wire the rack even before the CM16 is installed in the rack.

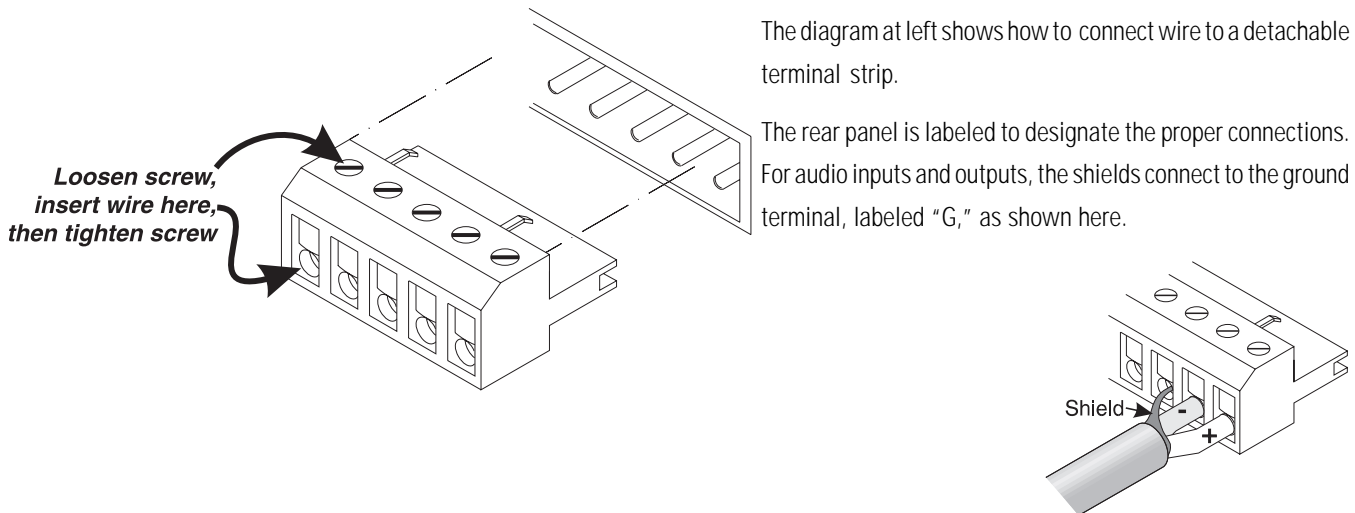

## PROGRAM INPUTS

Connect signal inputs for the CM16 to the terminal strip labeled **PROGRAM INPUTS**, which has 16 balanced signal inputs.

## PAGE

This is a single-channel balanced input for a paging signal, which can be inserted into any of the amplifiers. Like the CM16's other functions, it selects the signal source following commands from the system controller computer.

## MONITOR CHAIN

The CM16 provides three monitor points for each of the 16 individual amplifier signal paths: pre-fader, post-fader, and amplifier output. These points are selectable via the QSCControl2 software on the system controller computer, and each has a separate gain adjustment, also controlled via the system controller computer.

A line-level balanced monitor signal appears at the OUT terminals of the MONITOR CHAIN terminal strip. You can cascade multiple CM16 devices by connecting the monitor chain output of one to the monitor chain input of the next. The monitor signal would typically feed an auxiliary return on a mixing board, or a single-channel amplifier input, for remote monitoring purposes.

## CONTACT CLOSURES

Four switch-logic inputs on the CM16 allow remote sensing, signalling, or whatever you wish to program them as in a custom Visual Basic application on the system controller computer.

## ISOLATED CONTACT OUTPUTS

The CM16 has four relay outputs for actuating and controlling auxiliary devices via a custom Visual Basic application on the system controller computer. Each output set has a normally-closed (NC), a normally-open (NO), and a common terminal.

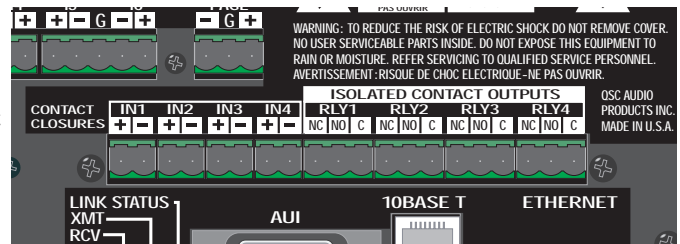

## III. SPECIFICATIONS

### CM16 MultiSignal Processor

#### Input signal processing

<b>Frequency response</b>	20 Hz–20 kHz $\pm 0.5$ dB
<b>Distortion</b>	<0.002% THD @ +4 dBu out
<b>Dynamic range</b>	>112 dB unweighted 22 Hz–22 kHz
<b>Data Port noise floor</b>	-90.5 dBu
<b>Polarity</b>	In-phase or inverted
<b>Gain control range</b>	0–86 dB in 0.5 dB steps
<b>Precision attenuator transients (“zipper” noise)</b>	better than 112 dB below maximum output
<b>Mute</b>	>86 dB attenuation

#### Inputs

Program inputs	16
Paging inputs	1
Monitor bus input	1
Connector type	“Phoenix-style” (a.k.a. “Euro-style”) detachable barrier strips
Type	Electronically balanced
Grounding	All shield terminals connected to chassis
Nominal level	+4 dBu/-10 dBV selectable
Maximum level	+21 dBu

Impedance	25 k $\Omega$ balanced
Common-mode rejection	>70 dB, 20 Hz–20 kHz
Crosstalk (inter-channel within Data Port pair)	<75 dB separation, 20 Hz–20 kHz
Crosstalk (intra-channel between Data Port pairs)	<108 dB separation, 20 Hz–20 kHz

#### Outputs

Program outputs	16 (via HD15)
Connector type	8 HD15 data port connections
Type	Special
Monitor output	1
Connector	“Phoenix-style” (a.k.a. “Euro-style”) detachable barrier strips
Type	Electronically balanced
Grounding	Shield terminal connected to chassis
Nominal level	+4 dBu
Maximum level	+21 dBu
Output impedance	75 $\Omega$ balanced
Output load	600 $\Omega$ minimum

#### Power amplifier output processing

##### Power amplifier output monitoring

Output short detect*	Senses load <1 $\Omega$ for Stereo/Parallel modes; <2 $\Omega$ in Bridged Mono mode
Output open detect*	Senses load >60 $\Omega$
Output voltage meter	Range automatically matches to amplifier model used

##### Output current meter

Range automatically matches to amplifier model used

\*Signal level must be higher than -32 dB, referenced to maximum output of amplifier

## Power amplifier management

### Power amplifier interface

Compatibility	OSC PowerLight models and other DP-1 compatible amplifiers
Connector and cable	HD15 VGA cable, 2 meters length qualified, maximum length TBD

### Channels

16 discrete channels (up to 8 dual-channel amplifiers)

### Amplifier status monitor

Clip indicator	Senses channel clipping
----------------	-------------------------

Protect indicator	Senses amplifier protect status
Temperature meter	Reports amplifier operating temperature

### AC power control

AC mode control	Switches amplifier between normal and standby mode (PowerLight models and DP-1-compatible models equipped with RPC [ <i>Remote Power Control</i> ] only)
AC power indicator	Indicates operate, standby, or power-down mode

## Control room foldback monitoring

### Signal monitoring buses (per CM16)

1

### Internal signal tap points

Pre-fader input signal	16
Post-fader input signal	16
Power amplifier output	16

### Monitor input

	Mixed with tap point signal at unity gain
Nominal level	+4 dBu
Maximum level	+21 dBu
Input impedance	25 k $\Omega$ balanced
Configuration	Active balanced, shield connected to chassis
Common-mode rejection	>75 dB 20 Hz–20 kHz

### Output

Sum of Monitor input and signal from internal monitor tap point

Frequency response	20 Hz–20 kHz $\pm$ 0.5 dB
Distortion	<0.05% THD @ +4 dBu out
Noise floor	-90.5 dB
Nominal level	+4 dBu
Maximum level	+21 dBu
Output impedance	75 $\Omega$ balanced
Output load	600 $\Omega$ minimum
Configuration	Active balanced

### Gain

Adjusts amplitude of signal from tap point

Monitor in to monitor out	0 dB, $\pm$ 1 dB
Control range	0 to -86 dB in 0.5 dB steps

## Contact closure inputs and outputs

### Inputs

	4 discrete inputs
Configuration	Single-ended input
Resistance for closure detect	<10 $\Omega$ max
Resistance for open detect	>1 k $\Omega$ min
Sense current	1.5 mA maximum
Ground limits ("-" input terminal)	Potential to case: 3V maximum Resistance to case: 100 $\Omega$

### Outputs

	4 discrete outputs
Configuration	Electromechanical relay contacts, floating
Maximum steady-state current	0.5 A
Maximum switched current	0.25 A
Ground isolation	70 volts maximum

### Connector

"Phoenix-style" (a.k.a. "Euro-style") detachable barrier strips



---

## Network Interface

---

<b>Physical network</b>	Ethernet	<b>Transport network</b>	TCP/IP family
Raw data rate	10 megabits per second	Internetwork protocol	IP
Frame format	D.I.X. (Ethernet)	Transport protocol	UDP
Connectors	RJ-45 female	<b>Application protocol</b>	QSC24
	AUI	Version	1
Ethernet types	10BASE-T (via RJ-45) one Media Attachment Unit (MAU)	Revision	7
Cable type	10BASE-T: twisted pair MAU (including but not limited to): 10BASE-F: optical fiber 10BASE-2: 50 $\Omega$ coax		
Max cable length	10BASE-T: 100 m to hub 10BASE-F: 5 km 10BASE-2: 635 m total		
Grounding	Floating		

---

## General

---

<b>Physical</b>		<b>AC Power</b>	
Height	3.5" (2 RU)	Voltage	75–110 VAC (labeled for 100V) 95–135 VAC (labeled for 120V) 200–255 VAC (labeled for 230V)
Width	19" (standard rack mount)	Current	1.1 A RMS (@ 100V) 1 A RMS (@ 120V) 0.5 A RMS (@ 230V)
Depth	16.75" (42.5 cm), plus 1" (2.5 cm) rear supports	Frequency	50 or 60 Hz
Weight	22 lbs (10 kg)	Disconnect	Detachable power cord with IEC connector
Mounting	Rear support recommended for portable or mobile use		
Operating temperature	0 to 50° Celsius		

## IV. ARCHITECT'S AND ENGINEER'S SPECIFICATIONS

The CM16 Power Amplifier Controller shall provide input, output, and status control for Data Port equipped QSC power amplifiers in an Ethernet-TCP/IP based network audio system. Sixteen independent channels shall be provided, grouped in pairs to support eight dual-channel power amplifiers.

**Amplifier Input Control and Monitoring**—For each of the sixteen power amplifier input signals, the CM16 shall provide gain, mute and polarity control, pre and post fade signal level metering and audio monitoring, and selectable +4 dBu/-10 dBV input sensitivity. The CM16 shall provide a page input, separate from the normal program inputs, whose signal may preempt the program signal of any or all of the sixteen program channels. This input shall have selectable +4 dBu/-10 dBV sensitivity.

**Amplifier Output Monitoring**—For each of the sixteen power amplifier outputs, the CM16 shall provide clipping detection, short and open circuit detection, voltage and current metering, and audio monitoring of the voltage signal.

**Amplifier Management**—For each of the eight dual-channel power amplifiers, the CM16 shall provide AC standby/operate mode control, AC power state indication, temperature metering, and protect status detection.

**Audio Monitoring Chain**—For each of the sixteen program channels, the CM16 shall provide three monitor points as follows: (1) pre-fader gain control, (2) post-fader gain control, or (3) power amplifier output. A channel's monitor output may be selected from one of these three signals, or it may be switched off. The signal at the CM16's monitor output connector shall be the sum of the signal at its monitor input connector and the sixteen channel

monitor signals. A monitor gain control shall be provided for each monitor tap point to adjust the individual levels of the channel monitor signals prior to their being mixed with the monitor input signal.

**Contact Closure I/O**—The CM16 shall provide four trigger contact-closure sense inputs which shall also be TTL signal compatible, and four dry-contact floating SPDT relay outputs.

**Data Network**—All CM16 functions shall be controlled and monitored via an Ethernet digital control network using the TCP/IP transport protocol and the QSC24 control and monitoring application protocol. Rear-panel connections shall be provided for 10BASE-T Ethernet, and an Ethernet AUI (Attachment Unit Interface) connector shall also be provided to interface with other Ethernet media. Other than the AC power switch and a network media type selector switch, the CM16 shall have no manual controls.

**Amplifier Interface**—The CM16's interface to each power amplifier Data Port shall be via an HD15 connector. The amplifier interface shall use a standard personal computer Video Graphics Adapter (VGA) CRT monitor cable. This interface shall transmit two amplifier input audio signals as well as all control and monitoring signals. Special signal conditioning and grounding techniques shall be used in this interface to ensure negligible levels of noise and crosstalk.

**General**—All audio inputs and outputs shall be balanced with a nominal input level of +4 dBu and maximum level of +21 dBu. Input connectors shall be of the "Phoenix" detachable terminal strip type.

# V.APPENDIX

## ETHERNET CABLING

This diagram shows the pinout for standard unshielded twisted-pair (UTP) network cable. Both ends of the cable are wired identically.

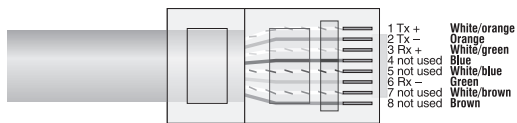

**RJ-45 pinout for a standard Ethernet patch cable (both ends identical)**

A crossover cable has the RX and TX wire pairs switched around at one end. There are only two likely situations that would require a crossover cable: to connect a single system controller computer directly to a single CM16 device; and to cascade hubs that don't have uplink ports.

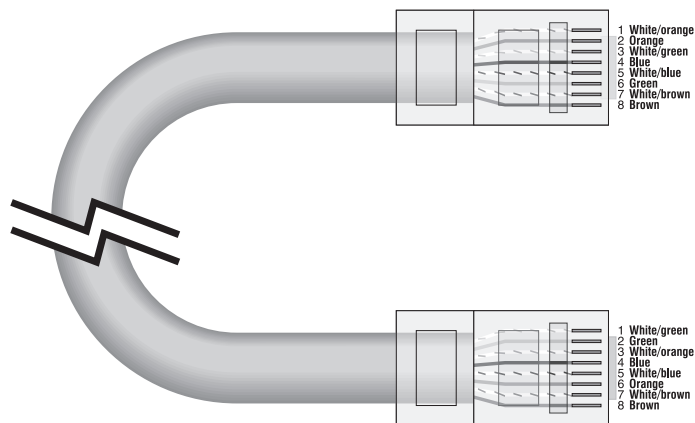

**RJ-45 pinout for an Ethernet crossover cable**

## DATA PORT PINOUT

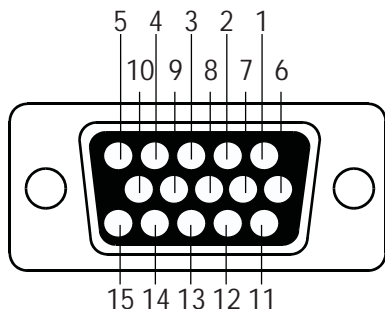

- 1 Audio to Channel 1 (+)
- 2 Standby control
- 3  $V_{MON}$  Channel 1 plus encode 1
- 4  $I_{MON}$  Channel 1 plus encode 2
- 5 Clip/protect Channel 1
- 6 Hard ground
- 7 Audio to Channel 1 (ground)
- 8 Audio to Channel 2 (ground)
- 9 unused
- 10 Amp reference ground
- 11 Audio to channel 2 (+)
- 12 Amp IDR (model ID)
- 13  $V_{MON}$  Channel 2 plus encode 3
- 14  $I_{MON}$  Channel 2 plus encode 4
- 15 Clip/protect Channel 2

### PowerLight

- |          |                            |
|----------|----------------------------|
| encode 1 | Bridge mode & power detect |
| encode 2 | Temperature, Channel 1     |
| encode 3 | Standby mode detect        |
| encode 4 | Temperature, Channel 2     |

### DP-1

- |          |                            |
|----------|----------------------------|
| encode 1 | Temperature, Channel 1     |
| encode 2 | Amp ID voltage             |
| encode 3 | Temperature, Channel 2     |
| encode 4 | Bridge mode & power detect |

## V.QSC ADDRESS & TELEPHONE INFORMATION

---

**Address:**

QSC Audio Products, Inc.  
1675 MacArthur Boulevard  
Costa Mesa, CA 92626-1468 USA

**Telephone Numbers:**

Main Number (714) 754-6175

Sales Direct Line (714) 957-7100

Sales & Marketing

(800) 854-4079

*(toll-free in U.S.A. only)*

Technical Services (714) 957-7150

(800) 772-2834

*(toll-free in U.S.A. only)*

**Facsimile Numbers:**

Sales & Marketing FAX  
(714) 754-6174

Technical Services FAX  
(714) 754-6173



World Wide Web:

<http://www.qscaudio.com>

BBS/World Group:

QSC OnLine Technical Support

1200-14400 bps; 8N1

(714) 668-7567

(800) 856-6003

CompuServe:

GOQSCAUDIO

ID: 76702,2635 or QSC\_AUDIO



1675 MacArthur Boulevard Costa Mesa, California 92626 USA PH: (714) 754-6175 FAX: (714) 754-6174

*"QSC" and the QSC logo are registered with the U.S. Patent and Trademark Office*