

Film-Tech

The information contained in this Adobe Acrobat pdf file is provided at your own risk and good judgment.

These manuals are designed to facilitate the exchange of information related to cinema projection and film handling, with no warranties nor obligations from the authors, for qualified field service engineers.

If you are not a qualified technician, please make no adjustments to anything you may read about in these Adobe manual downloads

www.film-tech.com

INSTALLATION AND OPERATION MANUAL

SMP 430 MAGNETIC PREAMPLIFIER



SMART THEATRE SYSTEMS

3870 N. Peachtree Rd., Suite E, P.O. Box 80361, Atlanta, GA. 30341, (404) 452-1820

SMP 430 MAGNETIC PREAMPLIFIER

The SMP 430 Magnetic Preamplifier is a modern, four channel solid state preamplifier designed specifically for use in motion picture theatres utilizing 35mm magnetic penthouse head clusters for stereo phonic sound. The unit may be used in multiples for dual projector installations or for 70mm applications. Each SMP 430 contains its own solid state changeover and temporary muting capability and can be used with manual or automation controlled switching formats. Each preamplifier channel has a balanced low impedance transformer coupled input with additional RF suppression circuits to assure quiet operation with minimum extraneous noise pickup from outside sources. A switchable 12 kHz filter in the surround channel preamplifier provides a very deep, narrow notch to reduce the control tone found on early cinemascope prints. This feature is valuable to theatres playing classic movies. A fully regulated bi-polar supply measures constant playback levels despite varying line voltages. Adjustable low frequency and high frequency controls allow the sound engineer to set the equalization curve for flat playback with the various brands of penthouses on the market. The equalization curve follows the newly adopted SMPTE standard of 3180ms and 35ms characteristics now used on both 35mm and 70mm magnetic release prints.

Before wiring the SMP 430, special consideration must be given to placement of the unit in the equipment rack. Because the product contains high gain circuits, it is important to keep the SMP 430 away from hum producing components contained in the other electronic units in the rack. The SMP 430 has no operator controls and can be easily placed as far as possible from exciter lamp supplies, power transformers and power amplifiers. This pre-planning can save time in troubleshooting hum and noise after the installation is complete.

INSTALLATION PRECAUTIONS

Magnetic sound systems are highly subject to noise and hum pickup because of the high gain circuits employed, long cables, and the abundance of magnetic fields generated by booth equipment. Carefully plan your job and avoid close proximity with problem equipment. Main motors used on some brands of projectors can also radiate 60 Hz and 120 Hz magnetic fields that are picked up by the head cluster. Check with the manufacturer if this occurs to see if a hum shield is available.

CABLES

If the SMP 430 is to be used to replace an old vacuum tube unit, it is a good idea to also replace the shielded cables from the penthouse with new low capacitance, two conductor, foil shielded cable. Foil shield provides a 100% shield, whereas the best braided shielded cable can produce a maximum of 94% shielding capability because of the tiny holes in the braid. DO NOT GROUND THE SHIELD AT THE PENTHOUSE END OF THE CABLE. Cut off the excess shield of each cable and wrap with electrical tape to prohibit the shield from accidentally touching a grounded projector part. The shield of each individual cable must be connected only to the BLACK ground terminal on the rear of the SMP 430. Keep the individual single conductors that protrude from the shield as short as practical to avoid noise pickup. Observe polarity of the color coded wires so that all channels remain in phase. An out-of-phase audio channel will cause bass cancellation and image shifting of the stereophonic program. Generally, the black conductor of the audio cable is regarded as the negative lead of the balanced audio pair and the lighter color is positive.

Cable routing from the penthouse to the preamplifiers should be as short and direct as possible. Avoid close placement of cable with motors, flourescent light ballasts, lamphouse power supplies, AC lines, etc.

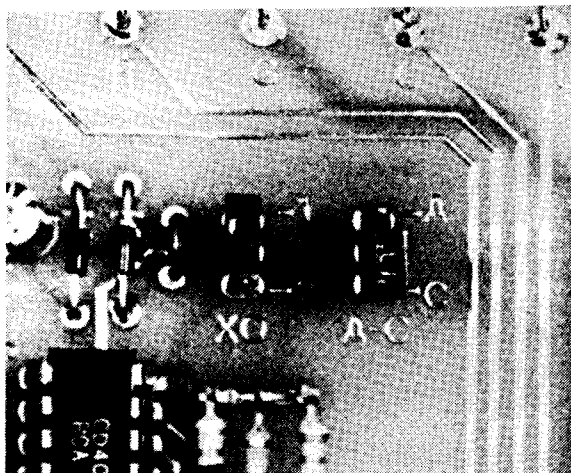

SHORTING "SHUNTS" ALLOW SELECTION OF DESIRED FUNCTION. "XO" IS THE CHANGEOVER OPTION, AND "A" & "C" SELECT MODE OF CHANGEOVER.

SINGLE PROJECTOR OPERATION

When the SMP 430 is used in a single projector installation, it will be necessary to lock the solid state changeover into a permanent mode of operation. Place the internal SHUNT in the Projector ONE position. Place the logic SHUNT in the "C" position. This will cause the unit to always stay in an ON state. Muting is still usable in this mode.

PROJECTOR ASSIGNMENT

When two SMP 430's are used together you must determine which unit is Projector ONE. Place the internal SHUNT in the Projector ONE position. The SHUNT in the second unit should be placed in the Projector TWO position.

TWO PROJECTOR INSTALLATIONS

Two SMP 430's must be used in a dual projector magnetic system. Switching two heads to one SMP 430 will result in severe "popping" and will not allow for channel equalization and level differences to be adjusted.

The SMP 430 uses a unique output switching method that allows several units to be combined in a system. This is handy when running 35mm and 70mm clusters through the same power amplifiers and auditorium speakers. When an SMP 430 is either muted or commanded to change over to another unit, the preamplifiers are disconnected from the output terminals by a quad electronic switch. This means that the output terminals of one unit can be directly connected to one or more units and each will pass sound only when commanded. Connect a short piece of hookup wire from the RED output terminal of one unit to the RED output terminal of the other SMP 430 unit(s). Do the same for each of the other output terminals. Connect a shielded audio cable from each channel to the next component in the system. Use the convenient BLACK ground terminal for shield connections. Place the internal SHUNT in the Projector ONE position on the first SMP 430, and in the Projector TWO position in the second unit.

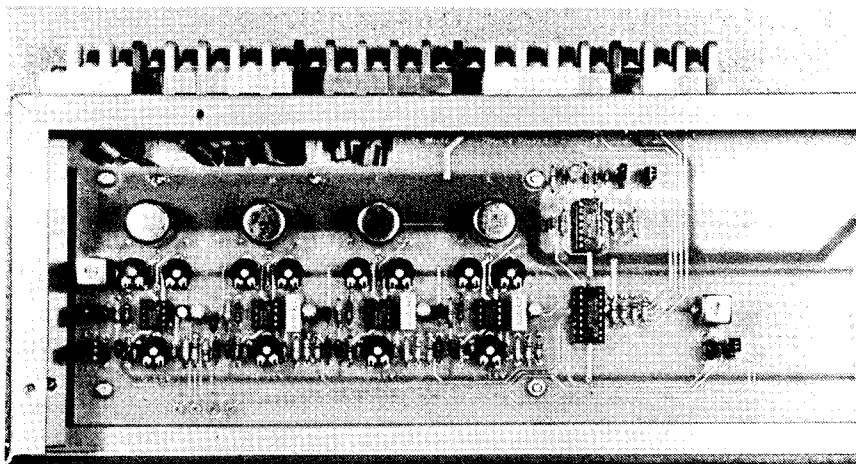

HEAD CLUSTER ALIGNMENT

Before adjusting the internal equalization controls in the SMP 430, verify that the head cluster is properly aligned for best high frequency response and correct phase. An SMPTE test film containing a 15 kHz alignment tone is suitable for this test. Since all heads are cemented together in the cluster, only the outside tracks need be checked. The SMP 430 may be used for this procedure. Align the heads for the highest reading on your dB meter or scope when monitoring the SMP 430 output on each respective channel. In addition to azimuth, head zenith should be checked for proper head-to-film contact and contour.

CHANGEOVER WIRING

There are three options to changeover penthouse audio when more than one SMP 430 is used in a system. Please read each option and determine which is best for your manual or automation system.

MUTING

When the VIOLET mute terminal on the rear terminal strip is grounded to a BLACK ground terminal, the 4 outputs will silently turn off. No audio will pass while the BLUE terminal is grounded. This feature is valuable in killing start-up noises or xenon strikes. Muting is generally a momentary state, but can also be used as a simple changeover between two SMP 430 units. A single SPDT switch will mute one unit while unmuting the other, and vice versa. Many SMP 430 units may be used in a single system through selecting muting.

ALTERNATE COMMAND CHANGEOVER

This method responds to a momentary ground from each projector sound changeover button. The solid state changeover logic will hold the selected penthouse on until a momentary ground causes the logic to switch and hold on the second penthouse. Place the internal SHUNT in the "A" position. Connect one end of a short wire to the WHITE Projector ONE changeover terminal. Connect the other end of this wire to the Projector ONE terminal of the second SMP 430. In the same manner connect another short wire from Projector TWO, WHITE changeover to the other unit. Do the same with the BLACK ground terminals. Now connect a pair of wires to either of the Projector ONE terminals and the Black ground terminal. This pair may be run to the automation equipment or remote manual changeover buttons. Manual switches should be momentary contact SPST type. Connect another pair of wires to Projector TWO terminals and the BLACK ground terminal. This line is run to the second manual changeover switch, or the automation system. A momentary short on each pair will cause the system to alternate between one SMP 430 and the other SMP 430 unit.

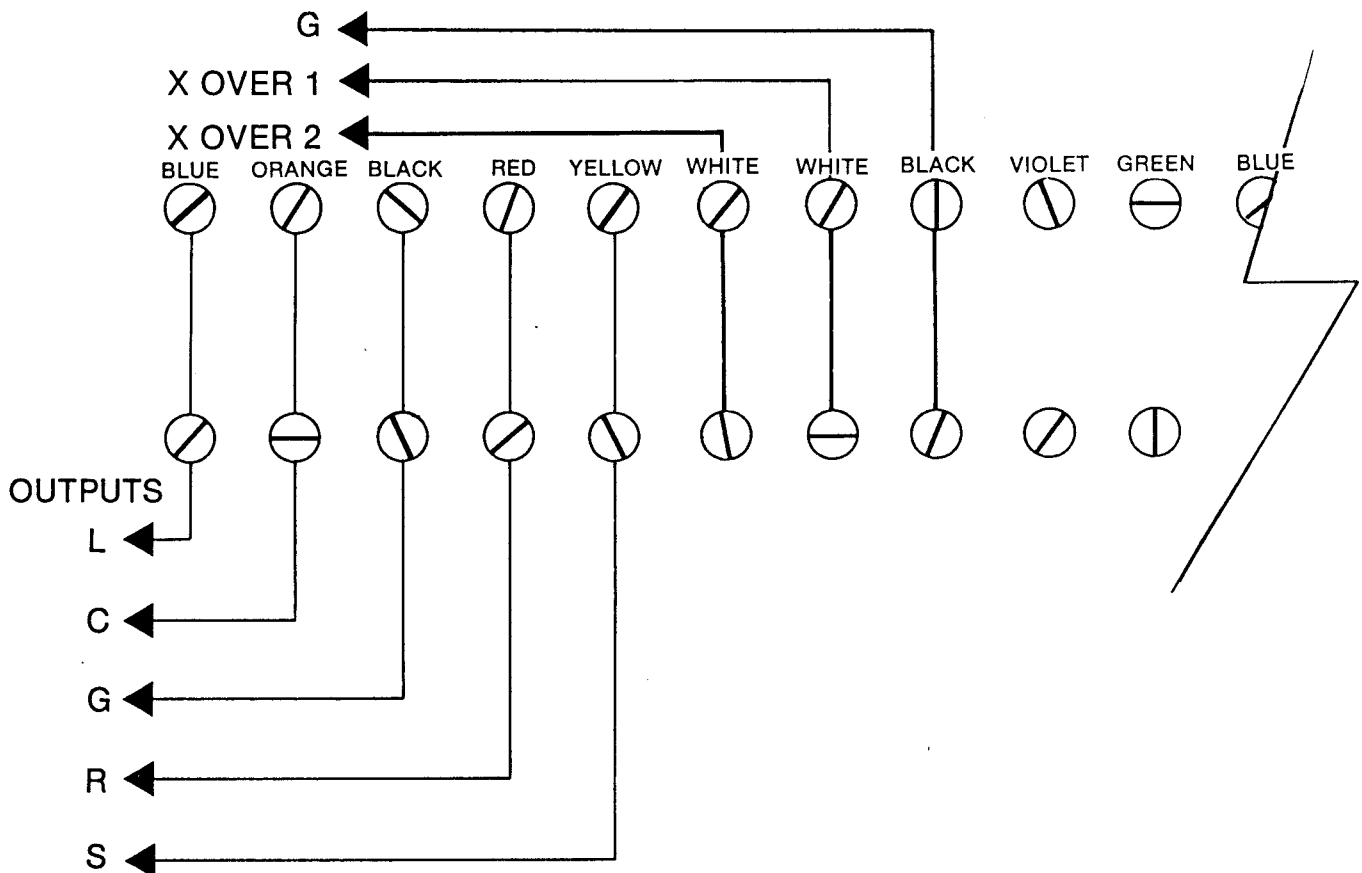

INPUT MATCHING

Most American penthouses contain either 5mH or 10mH heads. The SMP 430 will accept either type without any wiring changes. However, if the SMP 430 is to be used with a full coat magnetic reproducer instead of a penthouse, higher impedance heads will be encountered. Please contact the factory for details if you have special matching problems.

The input terminals of each channel of the preamplifier are color coded for easy identification. The BLUE terminals are the left channel inputs ORANGE is CENTER, RED is RIGHT, and YELLOW is SURROUND. Shields from each channel cable must be connected to the BLACK ground terminals between inputs.

OUTPUT WIRING

Connect individual cables from each output terminal to the next element in the system (fader, switcher, amplifier, etc.). Color coded terminals identify the channels. BLUE is LEFT, ORANGE is CENTER, RED is RIGHT, and YELLOW is SURROUND.

The low impedance output of the line amplifiers in the SMP 430 will work into either a low impedance or high impedance input of the next system element without difficulty. Each output is unbalanced. Check the input requirements of the product that follows the SMP 430 for proper input wiring requirements.

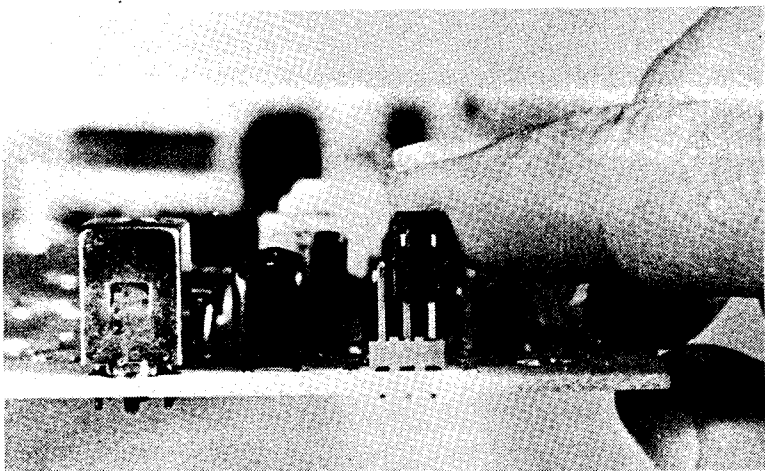

SHUNTS ARE PLASTIC CAPS WITH METAL SHORTING CONTACTS INSIDE. PULL SHUNT STRAIGHT UP AND PLACE IN DESIRED POSITION.

CONTINUOUS CHANGEOVER COMMAND

Another method of changeover between a pair of SMP 430's uses only a single pair of wires. Hookup is the same as the ALTERNATE command method, but a single pair is connected to Projector TWO changeover only. When this pair is shorted, the system will allow sound from the second unit to pass. When the wires are not shorted, sound from the first unit will pass. Place the internal SHUNT in the "C" position for this mode of operation. Run this pair to the automation equipment and connect to the "dry" pair of relay contacts that control sound changeover.

12 kHz FILTERS

The SMP 430 contains two frequency adjustable 12 kHz filters to remove the control tone placed on surround tracks of early release CinemaScope prints. Each filter will suppress the tone by 20 dB. If both filters are used, a very narrow 40 dB notch will be introduced. Move the internal SHUNT of either or both of the filters to the 12 kHz position. This feature may be controlled by a switch added to the front or rear panel of the SMP 430 by drilling a hole and adding a DPST switch. Tightly twist the wires running between the shunt pins and the new switch.

A screwdriver adjustment on the top of each silver filter can allow the sound engineer to move the filter notch when projectors are running slightly fast or slow. The filters are adjusted at the factory for precisely 12 kHz during the quality control test procedure.

MASTER FADER

An external 4 gang fader control may be added to the output of the SMP 430 when the equipment following this device has no ability to control level. A 10K per section 4 gang control similar to the Allen Bradley Mod Pot series is suitable. Also, the SMART 930 Stereo Buddy will provide a 4 channel electronic fader function in addition to intermission music fade capability.

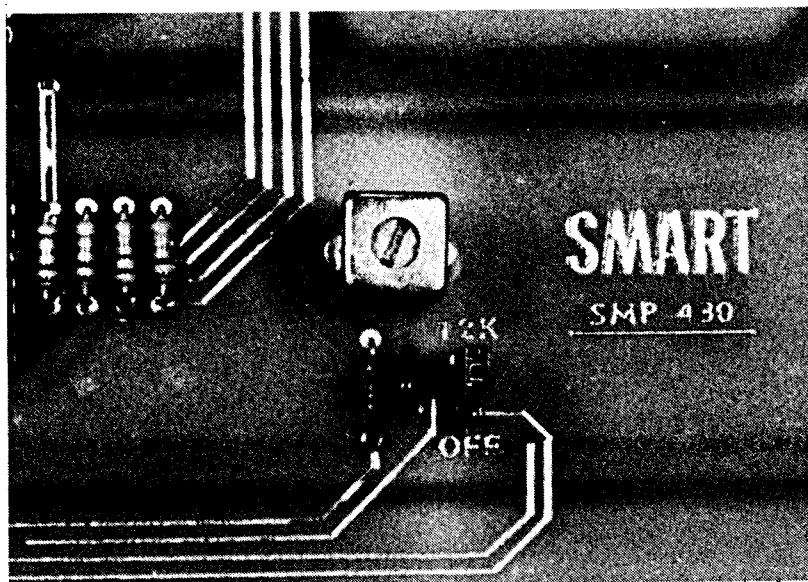

SHUNT IS MOVED TO 12 kHz POSITION FOR FILTER. THERE ARE TWO FILTER SECTIONS. ONE IS NEAR THE LEFT EDGE OF PC CARD. THE OTHER IS NEAR THE CENTER OF THE CARD.

OUTPUT LEVEL

Internal output level controls permit the sound engineer to balance the tracks and interface into the next device in the system. Clockwise rotation of each control will increase the output level of that channel. Keep in mind that the small surround track requires 6 dB more gain than the large front tracks in order to reproduce the same level.

PROPER EQUALIZATION

A high frequency and low frequency control permits accurate track equalization for each preamplifier in the SMP 430. The playback curve employed in this unit follows the new Academy Standard of 3180 ms and 35 ms equalization. Use a "pink noise" test film and real time analyzer, or SMPTE multi-frequency test film for equalization adjustments. Adjust controls of each channel for the most flat playback. The HF control allows an additional 10 dB of high frequency droop to be added if the house system sounds too bright when adjusted for flat playback. If no test equipment is available, turn the LF and HF controls fully clockwise and adjust counterclockwise for the best sound when using a print of known quality.

POWER SWITCH AND LAMP

The front panel Power Switch and L.E.D. allows the operator to turn the unit On and monitor AC power. The panel L.E.D. is connected across the power supply output and indicates that the supply is working.

EXTERNAL HOUSE EQUALIZATION

The SMP 430 may be followed by house equalizers in order to shape the playback to room acoustics and various speaker systems. We recommend one octave dual channel equalizers be used for maximum cost-to-performance ratio. These units are commonly available at low cost from HiFi or audio stores.

REMOTE L.E.D. INDICATOR

An external L.E.D. may be connected to each SMP 430 for remote "tally light" use in determining which unit of a multiple unit system is in use. Connect the anode of L.E.D. to the GREEN terminal on the rear terminal barrier strip, and L.E.D. cathode to the nearest BLACK ground terminal. Power for the L.E.D. originates from the SMP 430. Do Not Use external power.

70mm MAGNETIC PLAYBACK

Several SMP 430 units may be used together to provide extra channels for 70mm six track presentations. Dolby Cat. 22 decoding cards may be purchased through your Dolby franchise, or local recording equipment supply house to handle the necessary noise reduction decoding. These cards must be externally powered and separately housed in a rack mount card cage. The SMP 430 has sufficient level to drive the Cat. 22 cards directly without the use of external line amplifiers.

