

Film-Tech

The information contained in this Adobe Acrobat pdf file is provided at your own risk and good judgment.

These manuals are designed to facilitate the exchange of information related to cinema projection and film handling, with no warranties nor obligations from the authors, for qualified field service engineers.

If you are not a qualified technician, please make no adjustments to anything you may read about in these Adobe manual downloads.

www.film-tech.com

CINEMA FILM SYSTEMS, INC.

DIMMATIC LIGHTING CONTROL SYSTEM

CINEMA FILM SYSTEMS, INC.

DIMMATIC LIGHTING CONTROL SYSTEM

The Cinema Film Systems "DIMMATIC" is a full function incandescent lighting control system developed for motion picture theatre use. Its features include soft start to extend lamp life, preset bright level to reduce electrical power costs and flexibility that covers a very wide range of requirements. There are adjustable controls for the operational light levels and rate (speed) of dimming action. All components have been conservatively rated for very long life and the modular construction insures quick replacement in the event of a component failure.

The basic 2kw system may be expanded to include additional load circuits of up to 8kw or more. The design flexibility allows complete multi-function operation, with minor "field changes". Additional "future requirements", such as additional lighting circuits or "light curtains", require only the purchase of an additional power module.

The Dimmatic will operate with any type of control or system of automation, but is normally shipped with a provision for a "dry" momentary switch closure.

A valuable and original concept in the Dimmatic system is that of separating the "control" unit, and the power module (dimmer) section. This enables the control portion to be located where it is most convenient to each particular installation. It may be front wall mounted, installed in the automation or in the console cabinetry. It may also be located in the concession or manager area, for the only connection to the power module is a single un-shielded pair of wire, ie: thermostat, bellwire, etc. This unique feature allows the power module, or modules, to be placed adjacent to the AC breaker panel, and the termination of the conduit runs going to the branch lighting circuits. Choice of 2kw for each power module was chosen by requirements of the National Electrical Code; for this is the maximum permissible branch circuit allowed. This should, in most cases, result in cost savings in copper, conduit and installation time.

CINEMA FILM SYSTEMS, INC.

DIMMATIC LIGHTING CONTROL SYSTEM

The Film Systems Dimmatic system utilizes a new and different type of light modulation which allows precise and predictable control over the lighting load, and is not subject to low firing angle phase jitter, or false turn-on by xenon strike-up, or other spurious pulses common to other types of trigger circuits. As an additional benefit, introduction of hum modulation into those sound systems which are subject to this problem is eliminated.

Various interface modules are available to adapt the Dimmatic to almost any special requirements which a theatre may want to incorporate for more sophisticated lighting control.

CINEMA FILM SYSTEMS, INC.

DIMMATIC LIGHTING CONTROL SYSTEM

INSTALLATION INSTRUCTIONS

The Dimmatic is simple to install and involves only the following:

1. Mount the control module in any convenient location where the action of the dimmer on the lights may be viewed.
2. Mount the power module adjacent to the AC power panel for the booth, and the termination of the conduit runs to the branch lighting circuit. Note: The Dimmatic is well shielded and the design parameters are such that little RFI or audio noise are generated. However, depending on the particular sound system used, and its own shielding, it is best to mount the power module 6 to 8 feet away. In the case of the Dimmatic, where the control and power sections are separate, this should turn out to be the normal result of the layout. As is fairly standard (hopefully) amplifiers should be on their own circuit.
3. Electrical connections are shown on Drawing A00367.
 - a. Power Service to the power module and the lights.
 - b. Power to the control module.
 - c. Low voltage connection (2 wire thermostat, etc.) between the control module and the power module (observe polarity).
 - d. Low voltage connection (3 wire thermostat, etc.) to the automation and whatever stations are desired.
4. NOTE: On all shipments of more than one Dimmatic please try to keep the control module and its front panel controls, along with the power module(s) as a pair to avoid re-adjustment.

IMPORTANT. For the proper operation of the Dimmatic, both the control module and the power module(s) must be on the same phase as the booth power panel. If this is not done the lights will not dim fully out.

CINEMA FILM SYSTEMS, INC.

DIMMATIC LIGHTING CONTROL SYSTEM

INSTALLATION INSTRUCTIONS - (CON'T.)

5. DM-1 Dimmer Systems contain (1) control module and (1) power module.

DM-2 and DM-2 IL systems contain (1) control module and (2) power modules.

CONTROL MODULE ADJUSTMENT POTS

1. See Prints A03367 and A04367.
2. P1 Adjusts the speed (rate) of house lights from dim to bright and bright to dim.
3. P2 Adjusts the speed (rate) of stage lights from dim to bright and bright to dim.
4. P3 This trim pot sets the adjustment range of dim level of both house and stage lights. It is factory set to allow just a slight glow when lights are in full dim. It should not be adjusted unless absolutely necessary. If glow is too bright on dim, turn pot clockwise to diminish glow. Any further adjustments are not advised without contacting Film Systems.
5. P4 Stage bright adjustment - factory set at full clockwise.
6. P5 Stage dim adjustment - factory set at full counter clockwise.

FRONT PANEL ADJUSTMENTS

Controls on the front panel are determined by the type of dimmer.

Both DM-1 and DM-2 are equipped with master bright control (which controls house bright level) and house dim control (which controls house-light dim level). Both the DM-1 and DM-2 are equipped with a switch for manual control of the lights.

Controls on the dimmer with interim or 1/2 level feature are equipped with 1/2 level control marked Aux. Dim. as well as the normal dimmer control.

Switch on front panel will manually control both dimmers to full dim and full bright.

DUAL DIMMER OPERATION (DM-2)

The operation is as follows:

On the start of the show, house lights are pulsed down by supplying a momentary switch closure between terminal 10 & 12 of control module. House lights will dim down at an adjustable rate controlled by trim pot P1 (see Print A03367).

Stage lights are dimmed down by supplying switch closure between terminal 10 & 14 of control module. Stage lights will dim down at an adjustable rate controlled by trim pot P2 (see Print A03367).

At the conclusion of the show, house lights are cued to up position by supplying switch closure between terminal 10 & 11 of control module. The stage lights are cued to the up position by supplying switch closure between terminal 10 & 13 of control module.

Starting cue and concluding cue timing depends on type of automation used in connection to the control module.

SINGLE DIMMER OPERATION (DM-1)

Operation of DM-1 Dimmatic is similar to the DM-2 with the absence of the second set of lights.

INTERMITTENT LEVEL DIMMATIC (DM2-IL) OPERATION

The DM2-IL may be used to control house and stage lights with the intermittent level control of house lights.

The operation is as follows:

Control on front panel marked Aux. Dim is set to pre-determined dim position. On start, switch closure is supplied between terminal 10 & 14 of control module. House lights will dim to previous Aux. Dim setting. Stage lights will dim to full dim position. A second cue to switch closure is required between terminal 10 & 12. This will dim the house lights to full dim position.

At the conclusion of the show a cue to switch closure is required between terminal 10 & 11 of control module. This will raise house lights to pre-determined position. A final cue to switch closure between terminal 10 & 13 will start to raise stage lights. When stage level reaches the pre-determined house light level both house and stage lights will rise to full bright.

Pot P4 on control board (see Print A03367) controls both house and stage lights bright.

Pot P5 on control board (see Print A03367) controls both house and stage lights dim.

Pot house dim on front panel will control house dim level only.

Switch on front panel will manually control house and stage lights to full dim and full bright.

CINEMA FILM SYSTEMS, INC.
DIMMATIC LIGHTING CONTROL SYSTEM

GENERAL SPECIFICATIONS

Dimensions-----12" Wide x 8" High x 4" Deep
(2 cabinets)

Weight-----15 lbs.

Input Power-----117VAC 60 Hz 20A

TECHNICAL SPECIFICATIONS

Maximum Load-----2000W per power module

Maximum Load Current-----20A RMS

Peak 1 Cycle Load Current-----250A 60 Hz
230A 50 Hz

Control Current-----5mA Min.
11mA Typ.
50mA Max.

Control To Line Isolation-----7500 VAC

Control Wiring-----Class two

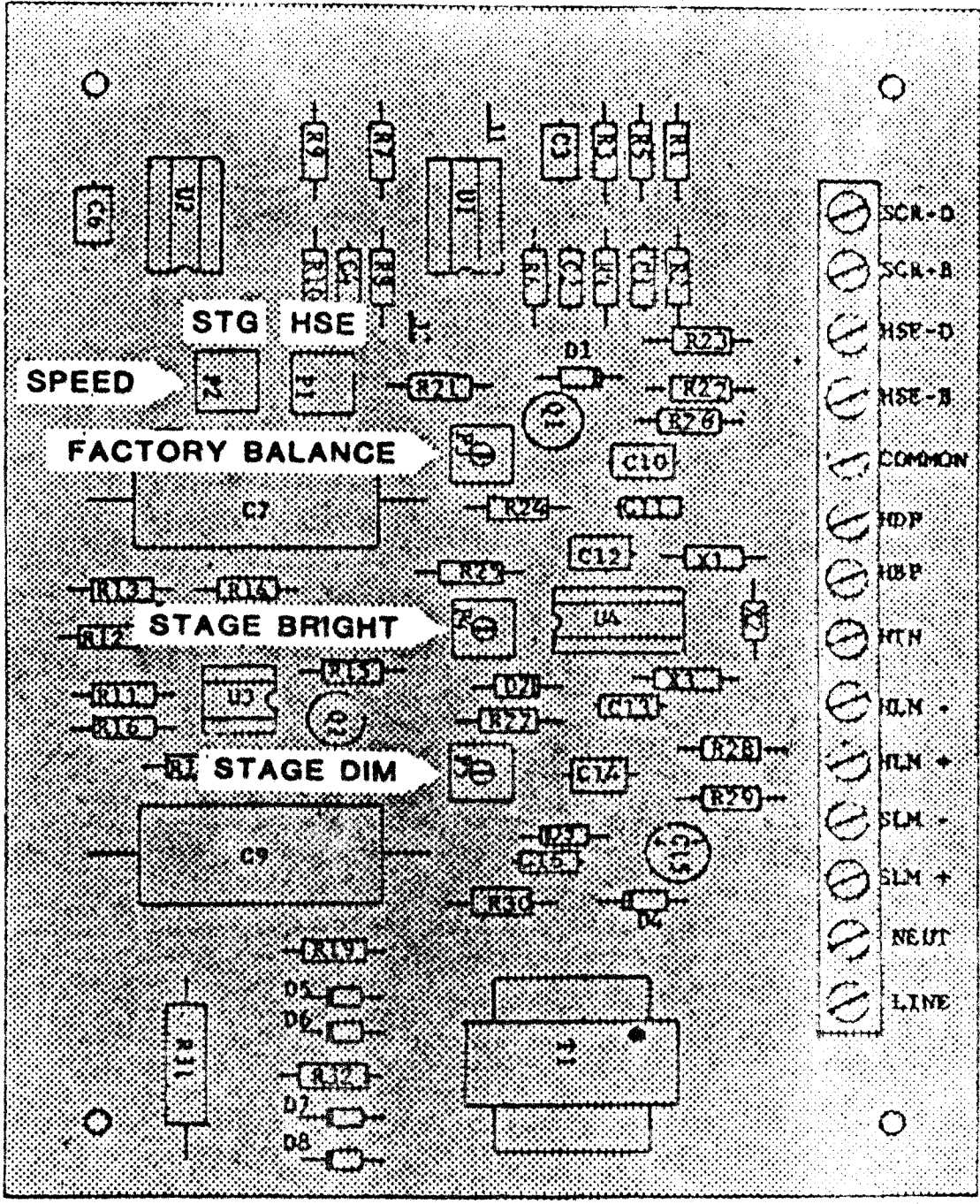

CINEMA FILM SYSTEMS, INC.
ADJUSTMENT POTS
 DATE 2/8/84 DRAWN BY CH
 DWG NO. A03367

CINEMA FILM SYSTEMS, INC.

PART IDENTIFICATION

DATE 2/8/84
DRAWN BY GM
DVC NO. A04367

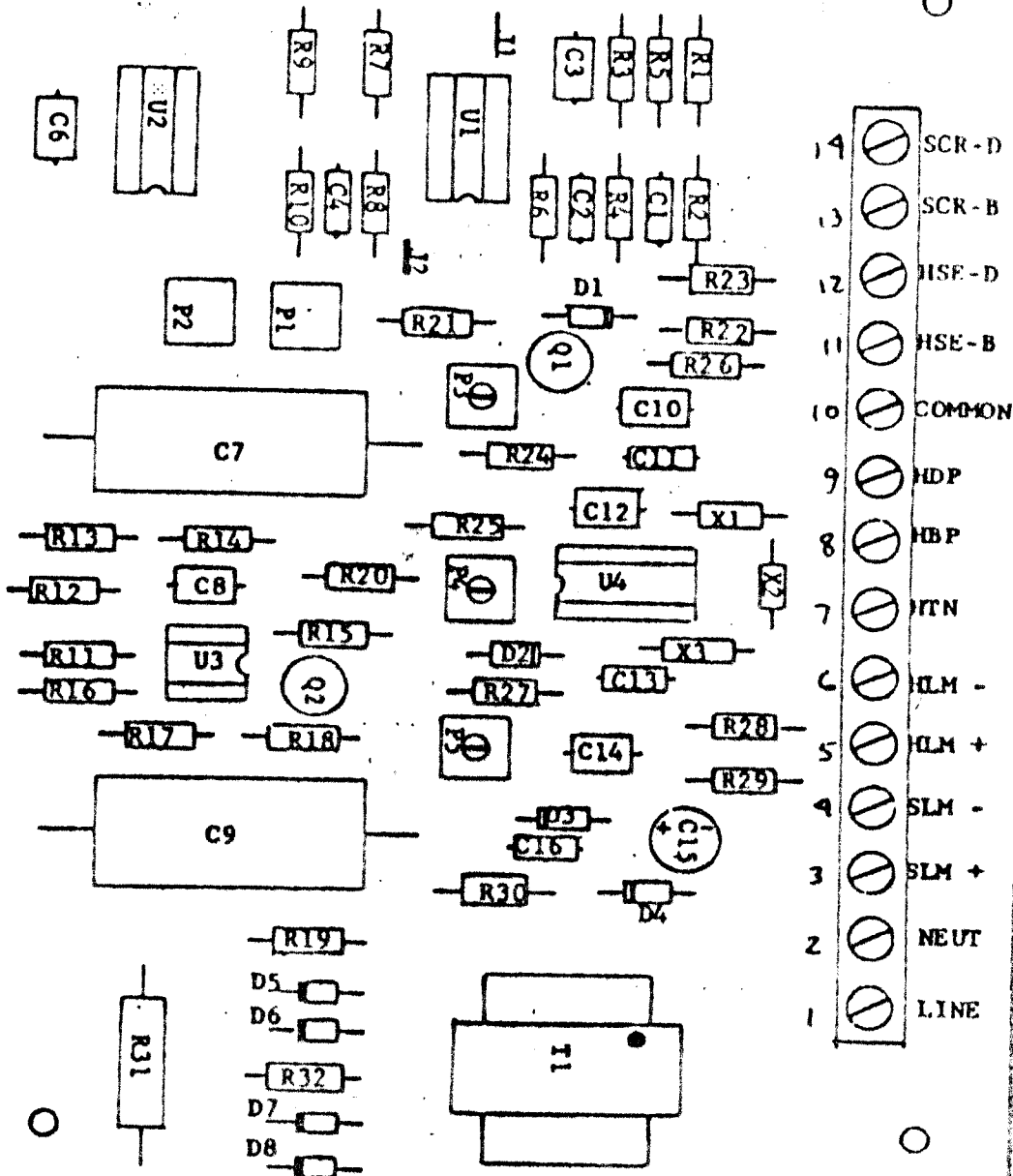

LINE (EXT BREAKER REC'D)

NEUT

NEUT

LOAD

CONTROL +

CONTROL -

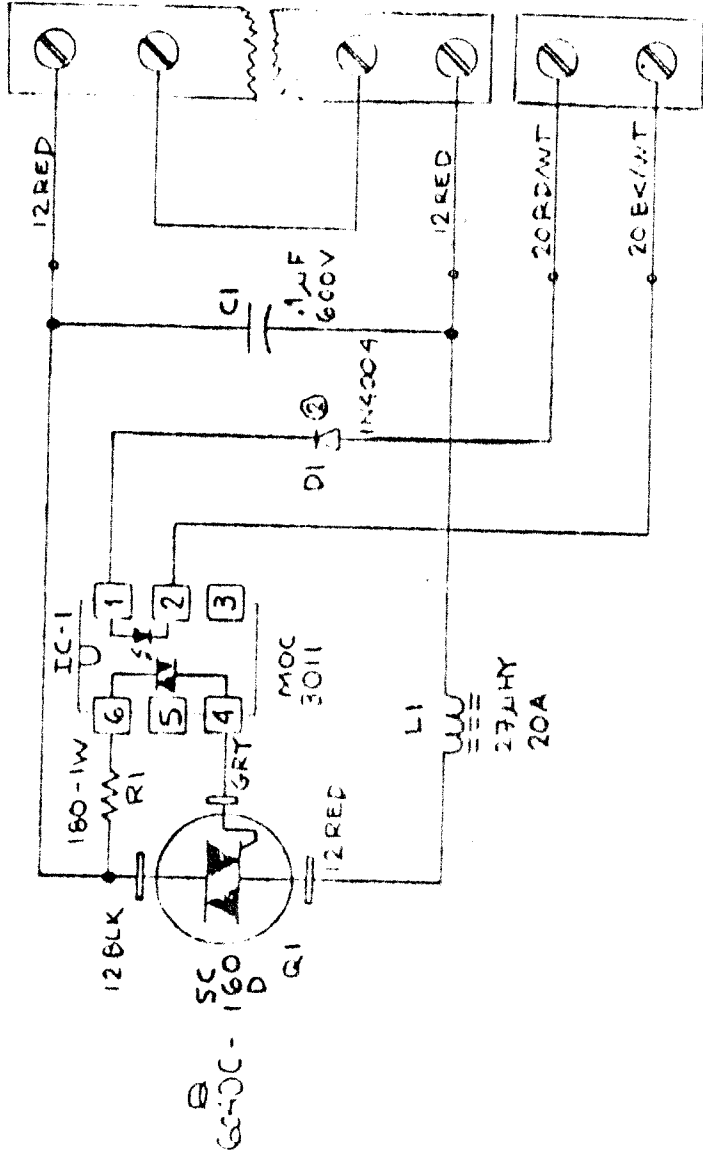

- (1) ALL COMPONENTS EXCEPT TRIAC ON PCB.
 - (2) TYPE "B" MODULE HAS 910Ω RESISTOR.
 - (3) CLASS-2 WIRING MAY BE USED FOR CONTROL.
- MAXIMUM RATED LINE VOLTAGE: 130V RMS, 50/60-HZ
 MAXIMUM RATED LOAD CURRENT: 100 RMS
 PEAK ONE-CYCLE SURGE CURRENT: 250A 60HZ
 230A 50-HZ
- CONTROL CURRENT: 5MA MIN; 11MA TYP; 50MA MAX.
 CONTROL TO LINE ISOLATION: 7500VAC

CINEMA FILM SYSTEMS, INC.	
WIRING POWER MOD.	
DATE 1/6/82	DWG NO. A01367
DRAWN BY UC9	

NOTE!
'Same Phase'

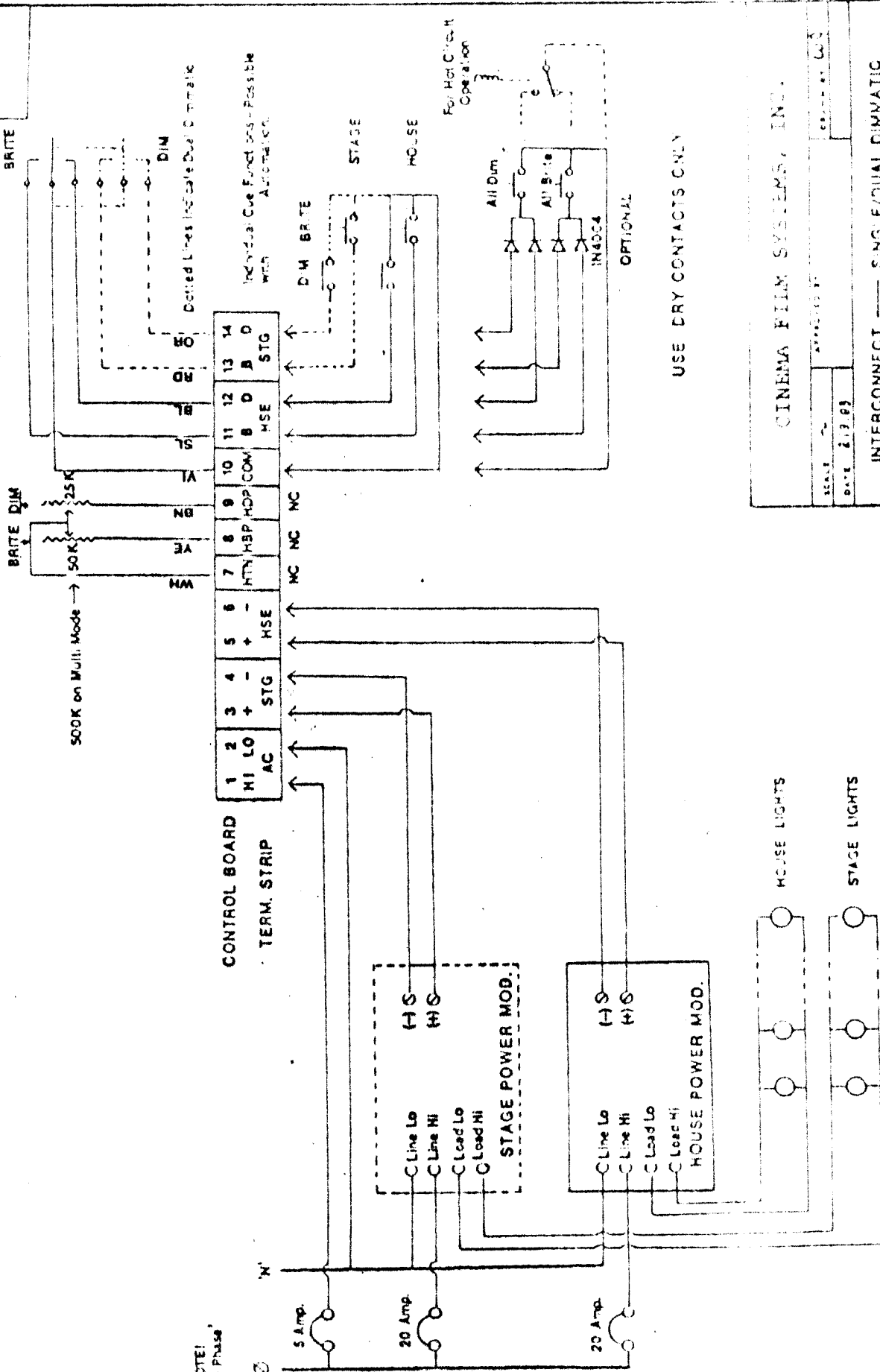

USE DRY CONTACTS ONLY

CINEMA FILM SYSTEMS, INC.

DATE 2.7.65

INTERCONNECT — SINGLE/DUAL DIMMATIC

DRUM NO. 00367

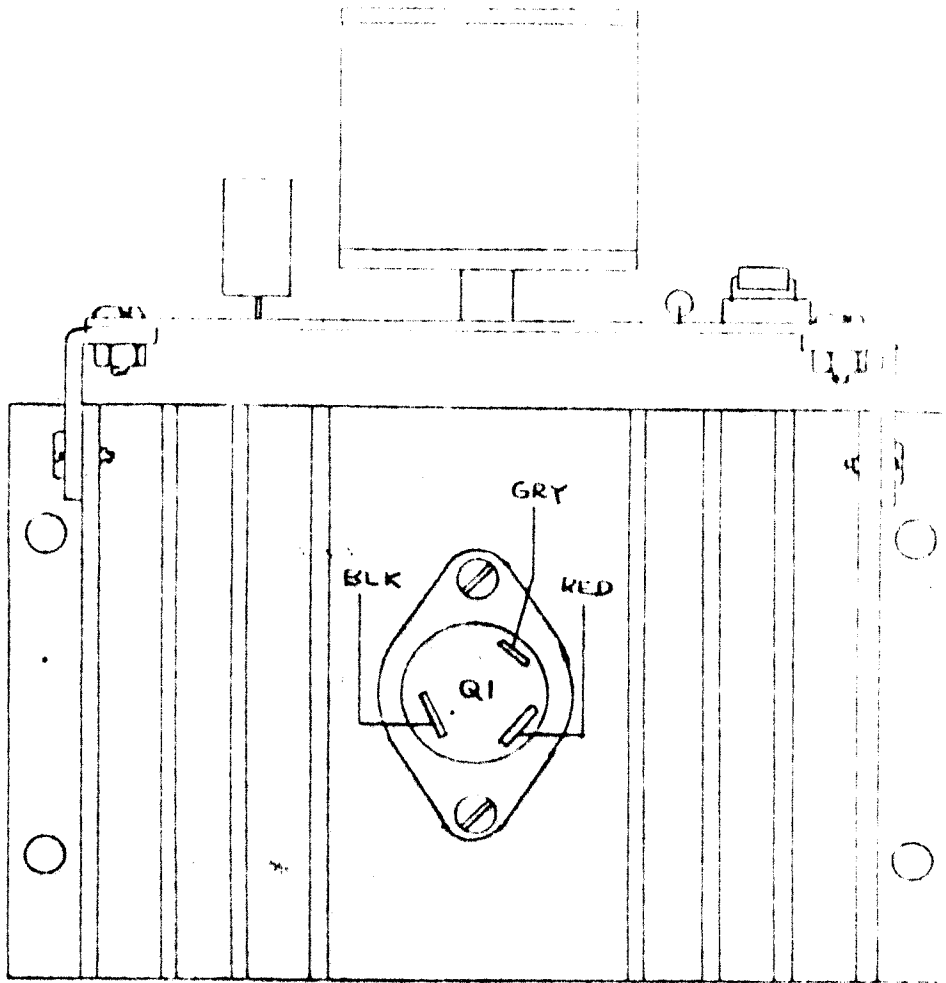

GE SC160D

CINEMA FILM SYSTEMS, INC.

LAYOUT POWER MOD.

DATE	1/8/62	DWG NO	A02367
		DRAWN BY	WJ

